

**Lower Thames Crossing  
6.3 Environmental Statement  
Appendices  
Appendix 6.8 – Trial Trenching  
Reports (Volume A)**

APFP Regulation 5(2)(a)

Infrastructure Planning (Applications:  
Prescribed Forms and Procedure)  
Regulations 2009

Volume 6

**DATE: October 2022**

Planning Inspectorate Scheme Ref: TR010032  
Application Document Ref: TR010032/APP/6.3

**VERSION: 1.0**

# Lower Thames Crossing

## 6.3 Environmental Statement Appendices

### Appendix 6.8 – Trial Trenching Reports (Volume A)

#### List of contents

#### Volume A

Archaeological Evaluation Report for Trial Trenching of Land Parcel 1 Masons Corner, Heath Road, Orsett Heath, Essex

OA Archaeological Evaluation Report for Trial Trenching of Land Parcel 2

Archaeological Evaluation Report for Trial Trenching of Land Parcels 3 (North), 30 and 35

Archaeological Evaluation Report for Trial Trenching of Land Parcel 3 Hornsby Lane, Orsett Heath, Essex

Archaeological Evaluation Report for Trial Trenching of Land Parcel 4 Old House, Chadwell St Mary, Essex

Archaeological Evaluation Report for Trial Trenching of Land Parcel 5 Brook Farm, Essex

Archaeological Evaluation Report for Trial Trenching of Land Parcels 6-8, Land West of Linford, East Tilbury, Essex

Archaeological Evaluation Report for Trial Trenching of Land Parcels 6, 8, 9, 10 and 36

Archaeological Evaluation Report for Trial Trenching of Land Parcel 12, Land South of Low Street, Tilbury Marshes, Essex

#### Volume B

OA Archaeological Evaluation Report for Trial Trenching of Land Parcel 21

Archaeological Evaluation Report for Trial Trenching of Land Parcel 22 Whitfield South Scheduled Monument Cropmark Complex, South of Stifford Clays Road, Baker Street, Essex

Archaeological Evaluation Report for Trial Trenching of Land Parcels 3 (North), 30, 31, 35, 103, 104 and 107 Land Bordering the A13 at Orsett, Essex

Archaeological Evaluation Report for Trial Trenching of Land Parcel 37

Archaeological Evaluation Report for Trial Trenching of Land Parcels 55, 56 and 58

## **Volume C**

OA Archaeological Evaluation Report for Trial Trenching of Land Parcel 24, 25, 26, 28 & 29

Archaeological Evaluation Report for Trial Trenching of Land Parcels 40 and 49, North Ockendon, London Borough of Havering

Archaeological Evaluation Report for Trial Trenching of Land Parcels 41, 42, 44 and 60 Land South of Ockendon, in Thurrock, Essex, and the London Borough of Havering

Archaeological Evaluation Report for Trial Trenching of Land Parcels 43, 45A-E and 46 Mar Dyke Valley, between South Ockendon and Orsett

Archaeological Evaluation Report for Trial Trenching of Land Parcels 47 and 48f-h, Mar Dyke Valley between South Ockendon and Orsett, Essex

Archaeological Evaluation Report for Trial Trenching of Land Parcels 48B and 48C Mar Dyke Valley, between South Ockendon and Orsett

## **Volume D**

Archaeological Evaluation Report for Trial Trenching of Land Parcels 54 and 126 Land North of North Ockendon, London Borough of Havering

Archaeological Evaluation Report for Trial Trenching of Land Parcels 71, 72 and 75 Land east of Gravesend and either side of the A226, Chalk, Kent

Archaeological Evaluation Report for Trial Trenching of Land Parcels 76 and 77

## **Volume E**

Archaeological Evaluation Report for Trial Trenching of Land Parcels 80 and 81

## COVER SHEET

<b>Title:</b>	<b>Archaeological Evaluation Report for Trial Trenching of Land Parcel 1 Masons Corner, Heath Road, Orsett Heath, Essex</b>
<b>Project Name:</b>	<b>Lower Thames Crossing Enabling Works</b>
<b>Ref No:</b>	<b>HE540039-BAL-GEN-GEN-REP-HER-00020</b>
<b>Revision No:</b>	<b>PO2</b>
<b>Review Date:</b>	<b>27<sup>th</sup> March 2020</b>
<b>Status:</b>	<b>S3</b>
<b>No. of Pages</b>	<b>63</b>

<b>Rev</b>	<b>Date of Issue</b>	<b>Revision Status</b>	<b>Originator</b>	<b>Checker</b>	<b>Approver</b>
PO1	21.01.2020	S3 For Review and Comment	Paulo Bento	Paulo Pinho	George Pargeter
PO2	30.03.2020	S3 For Review and Comment	Jack Kilburn	Peter Chartier	George Pargeter



# Lower Thames Crossing

Archaeological Evaluation Report for Trial Trenching of  
Land Parcel 1  
Masons Corner, Heath Road, Orsett Heath, Essex

Document Number: HE540039-BAL-GEN-GEN-REP-HER-00020

**January 2020**



<b>Revision</b>	<b>Production Date</b>	<b>Prepared by</b>	<b>Checked by</b>	<b>Approved for release by</b>	<b>Sections revised</b>
1.1	17th January 2020	<i>Kirsty Smith Oxford Archaeology</i>	<i>Steve Lawrence Oxford Archaeology</i>		
1.2	20th January 2020	<i>Kirsty Smith Oxford Archaeology</i>	<i>Edward Biddulph Oxford Archaeology</i>		

This Evaluation Report has been prepared for Highways England in accordance with the terms and conditions of appointment stated in the Lower Thames Crossing (LTC) Technical Partner Contract. LTC cannot accept any responsibility for any use of or reliance on the contents of this document by any third party.

# Contents

---

Section	Page
<b>Summary</b> .....	<b>6</b>
<b>Acknowledgements</b> .....	<b>7</b>
<b>1 Introduction</b> .....	<b>8</b>
1.1 Project details and scope of work .....	8
1.2 Location, topography and geology .....	9
1.3 Previous investigations .....	9
1.4 Archaeological and historical background.....	10
<b>2 Project Aims</b> .....	<b>13</b>
2.1 General aims .....	13
2.2 Specific objectives .....	14
<b>3 Methodology</b> .....	<b>16</b>
3.1 Constraints.....	16
3.2 Methodology for the evaluation .....	16
<b>4 Results</b> .....	<b>17</b>
4.1 Introduction and presentation of results .....	17
4.2 General soils and ground conditions.....	17
4.3 General distribution of archaeological deposits .....	17
4.4 Trench 3.....	18
4.5 Trench 5.....	18
4.6 Trench 6.....	18
4.7 Trench 20.....	18
4.8 Trench 21.....	18
4.9 Trench 22.....	18
4.10 Trench 26.....	19
4.11 Trench 27.....	19
4.12 Trench 28.....	19
4.13 Trench 29.....	19
4.14 Trench 33.....	20
4.15 Trench 38.....	20
4.16 Trench 40.....	20
4.17 Trench 43.....	20
4.18 Trench 47.....	20
4.19 Finds summary .....	21
4.20 Environmental summary .....	21
<b>5 Discussion</b> .....	<b>22</b>
5.1 Reliability of field investigation .....	22
5.2 Interpretation.....	22
5.3 Evaluation objectives and results.....	24
<b>Appendix A Trench Tables</b> .....	<b>26</b>
<b>Appendix B Finds Reports</b> .....	<b>43</b>

<b>Appendix C</b>	<b>Environmental Reports .....</b>	<b>45</b>
<b>Appendix D</b>	<b>References .....</b>	<b>46</b>
<b>Appendix E</b>	<b>Abbreviations and Glossary .....</b>	<b>48</b>
<b>Appendix F</b>	<b>Site Summary.....</b>	<b>49</b>



## Figures

Figure 1 - Map showing the location of Land Parcel 1

Figure 2 - Plan of trench layouts, cropmark features and archaeological features

Figure 3 - Plan of Trench 6

Figure 4 - Plan of Trench 20, 21 and 22

Figure 5 - Plan of Trench 26 and 27

Figure 6 - Plan of Trench 28, 29 and 40

Figure 7 – Plan of Trench 38, 43 and 44

Figure 8 – Sections (Trenches 20, 21, 22, 26 and 27)

Figure 9 – Sections (Trenches 28, 38, 40 and 43)

## Plates

Plate 1 - Ditch 2102 facing north-east

Plate 2 - Ditch 2603 facing south

Plate 3 - Ditch 2704 facing west

Plate 4 - Posthole 2803 facing east

Plate 5 - Pit 3803 facing south

Plate 6 - Ditch 4004 facing north-east

## Summary

---

Oxford Cotswold Archaeology was commissioned by Balfour Beatty to undertake a trial trench evaluation of Land Parcel 1 of the Lower Thames Crossing Pre-Enabling Works. Land Parcel 1, also known as Masons Corner, is located c 200m north of the hamlet of Orsett Heath within the county of Essex and Thurrock unitary authority (NGR 563914 180335). The evaluation comprised 49 trenches and was completed between the 28th November and the 6th December 2019.

Two trenches in the north-western part of the site contained features that were dated to the late Bronze Age, including a NE-SW ditch, a pit and a posthole. This indicates late Bronze Age activity in this area, although a more detailed interpretation of this is not possible from the scant remains encountered.

A number of undated archaeological features were identified within the northern, eastern and south-western part of the site, including two postholes, a NW-SE aligned ditch, a NE-SW aligned ditch, a NW-SE aligned gully and four pits.

Two NNW-SSE aligned ditches in the western part of the site match a linear cropmark and a field boundary on the Orsett 1840 tithe map and are very likely post-medieval in date. Another NE-SW ditch was also thought to be post-medieval as it also matched a cropmark that was perpendicular to the NNW-SSE aligned linear.

The site contained a large number of irregular-shaped features, 1-3m in diameter, which were identified as cropmarks and were targeted in numerous trenches. Where investigated, these comprised variations in the gravel or sand and silt content of the geology and were clearly not of archaeological origin.

## Acknowledgements

---

Oxford Cotswold Archaeology would like to thank the client, Balfour Beatty, for commissioning this project and managing the site safety and attendances. Thanks are also extended to the Historic Environment Consultants (Richard Havis and Katie Lee-Smith) of Place Services for Essex County Council advising the Borough of Thurrock, for monitoring and providing advice throughout the project.

The project was managed for Oxford Cotswold Archaeology by Steve Lawrence. The fieldwork was directed by Mark Dodd and Anna Moosbauer, who were supported by Robert McIntosh, Jana Smirnova, Adam Moffat, Megan Lillington, Dan Firth, Eilidh Barr, Fanny Dubuc and Adrian Arenas. Site survey was undertaken by Caroline Souday and Rachel Alexander and digitising was carried out by Gary Jones, Benjamin Brown and Simon Batsman. Thanks are also extended to the teams of OA staff that cleaned and packaged the finds under the management of Leigh Allen and Geraldine Crann, processed the environmental remains under the management of Rebecca Nicholson, and prepared the archive under the management of Nicola Scott.

# 1 Introduction

---

## 1.1 Project details and scope of work

- 1.1.1 The Lower Thames Crossing Project is located between the A2 in Kent and the M25 in the London Borough of Havering. It will run underneath the River Thames through a tunnel and emerge on the northern side of the river at East Tilbury. From the North Portal the road will run to the M25 at Junction 29 via the A13 and pass between North and South Ockendon. The development of the project is managed by LTC, a partnership between Highways England and a consultancy joint venture set up to oversee the scheme.
- 1.1.2 A programme of archaeological trial trenching began in the Essex part of the scheme in November 2019. A scheme-wide specification for trial trenching was written by LTC (Highways England 2018), and in July 2019 LTC commissioned Balfour Beatty to deliver the pre-Enabling Works. Balfour Beatty appointed Oxford Archaeology (hereafter OA) to prepare a project-wide written scheme of investigation (WSI) for the scheme, which (at the request of the key archaeological stakeholders) is divided into two parts, one for the Kent section, the other for Essex and Havering (Oxford Archaeology 2019a, 2019b).
- 1.1.3 Following completion of the project-wide WSIs, OA was also instructed to prepare a series of site-specific or group-site specific WSIs for approval by the key archaeological stakeholders in advance of trial trenching to inform the Development Consent Order (DCO). A detailed WSI was created for Land Parcel 1 prior to the trial trenching (Oxford Archaeology 2019c). The WSI details the archaeological background and potential within Land Parcel 1 (Oxford Archaeology 2019c). It also indicated the archaeological aims and objectives appropriate to the investigation of this land parcel by trenching, and set out the methodology. This WSI was approved by Richard Havis, Principal Historic Environment Consultant for Place Services, Essex County Council, prior to the start of the fieldwork. Oxford Cotswold Archaeology was commissioned as Balfour Beatty's archaeological contractor to undertake the evaluation in accordance with the approved WSI and local and national planning policies.
- 1.1.4 The fieldwork was completed between the 28th November and the 6th December 2019. All work also followed the MoRPHE Project Manager's guide (Historic England 2015), and the Code of Conduct of the Chartered Institute for Archaeologists (CIfA). The archaeological works adhered to the standards and guidance for archaeological evaluation, excavation and archiving (CIfA 2014a; CIFA 2014b).
- 1.1.5 The work was monitored by Richard Havis and Katie Lee-Smith, Place Services, ECC advising the Borough of Thurrock.

## 1.2 Location, topography and geology

- 1.2.1 Land Parcel 1 is located c 200m north of the hamlet of Orsett Heath (Fig. 1) within the county of Essex and Thurrock unitary authority (NGR TQ 63914 80335). It is sub-square in shape, and covers an area of 8.43ha. This land parcel is also located 300m south of the A13 and 100m east of the A1089. Heath Road, which serves houses just beyond the western edge of the site, runs parallel to the A1089 and lies just outside the south-west corner of the site. The parcel is bounded to the north by the A1013, to the east by both the Whitecroft care home and an open field, to the south by an open field and to the west by Heath Road and the properties adjoining it.
- 1.2.2 The bedrock geology of Land Parcel 1 is mixed, being Thanet Formation (sand) in the southern half of the site and Lambeth Group - clay, silt and sand in the northern edge of the land parcel. The whole site is covered by superficial geology of the Boyn Hill Gravel Member (sand and gravel) which was formed in the Quaternary Period up to 2 million years ago (BGS 2019).
- 1.2.3 The land is currently in use as an arable field. Within the 1km site buffer the land use is a mixture of agricultural land and urban development associated with the town of Grays to the south-west, Orsett Heath and Chadwell St Mary to the south and the hamlet of Baker Street to the north.
- 1.2.4 The site is situated on an upland area to the south of Orsett and is relatively flat at 25m aOD, although it rises slightly to the north-west, up to 26m aOD along the A1013, and drops slightly towards the south end. The Mar Dyke valley lies 1.2km to the north-west, and this is the nearest large river to the site.

## 1.3 Previous investigations

- 1.3.1 No known below-ground archaeological investigation has been undertaken within this land parcel.

## 1.4 Archaeological and historical background

- 1.4.1 The chronological summary of known archaeology given below is taken from the detailed WSI for Land Parcel 1 (Oxford Archaeology 2019c). The site is situated on the terrace to the south of the Mar Dyke valley where Holocene prehistoric features, find spots and cropmarks have been identified. The cropmarks that have been recorded within the site are those mapped by the 'Aerial Investigation and Mapping Report' (Place Services 2019). These cropmarks are shown on Figure 2.
- 1.4.2 **Palaeolithic.** A number of individual Palaeolithic artefact find spots have been recorded 0.6-1km to the south and 0.6km to the east of the site.
- 1.4.3 **Mesolithic.** Mesolithic finds spots have been recorded 0.4-0.6km to the south-east and 0.6-0.8km to the south of the site.
- 1.4.4 **Neolithic.** A scheduled early Neolithic causewayed enclosure (Aerial Investigation and Mapping Report site 17A) is located 1km east of the site, and find spots of Neolithic flints are recorded just north-west of this. Neolithic flints have also been recorded across several fields 0.6-0.8km south-east of the site. A cropmark narrow rectangular enclosure, aligned east-west with rounded ends is known only 40m from the south-east corner of the site, and from its morphology this is suspected to be a mortuary enclosure of Neolithic date.
- 1.4.5 **Bronze Age.** The site is located 1km south-east of the Orsett (Grey Goose Farm) Cropmark Complex. This is a scheduled monument that comprises an extensive and dense multi-period site. It includes two adjacent circular ring ditches on the edge of the terrace which may represent early Bronze Age barrows (Aerial Investigation and Mapping Report 13, 14 and 15).
- 1.4.6 Several late Bronze Age to early Iron Age features were identified during the Baker Street excavation along the A13, located c 600m north-west of the site. This included one large pit, a gully and three small pits 0.25-0.5m in diameter, which contained flint-gritted pottery and charcoal, and eight postholes containing fired clay and charcoal. The eight postholes may have formed an oval building measuring 4.5 by 6m (Wilkinson 1980, 15-16).
- 1.4.7 The cropmark of a possible ring-ditch which may well represent a ploughed-out round barrow was identified only 40m north of the site (Aerial Investigation and Mapping Report site 21).
- 1.4.8 **Iron Age.** The Neolithic causewayed enclosure located 1km east of the site was overlain by an unenclosed early Iron Age site and a middle Iron Age sub-rectangular enclosure (Hedges and Buckley 1978, 219-308). Cropmarks including pits, linear features and ring ditches extend from the area of the scheduled early Iron Age enclosure both south-west towards the site and north-west (Aerial Investigation and Mapping Report sites 17A, 17B and 72). Within these a sub-rectangular enclosure some 0.6km east of the site may well be of Iron Age date.

- 1.4.9 A large quantity of high status Iron Age material was recovered by metal detectorists from a field 0.6km east of the site and within the area of the scheme. This find spot may have been located within an extensive rectilinear enclosure located 0.2km east of the site (discussed below). Two Iron Age vessels were also found 0.5km north of the site.
- 1.4.10 **The Roman period.** A late Iron Age to late Roman farmstead and several possible Roman sites are located on the gravel ridge 1-1.5km north-west of the site.
- 1.4.11 An extensive cropmark complex that includes one very large rectilinear enclosure and several smaller ones linked by trackways or field boundaries was identified by the aerial survey 0.2km east of the site (Aerial Investigation and Mapping Report site 20). The large enclosure is on a north-west to south-east alignment and contains sub-divisions, pits and curvilinear smaller enclosures. Another trackway is evident a little further south leading SSE to a further cropmark enclosure south of the scheme, which was characterized as late Iron Age or Roman (Buckley, Hedges and Priddy 1987).
- 1.4.12 **The medieval period.** Mid-Saxon activity has been identified east and north-east of the site. The Orsett causewayed enclosure was reused as a Saxon funerary monument in the 7th-8th century. A Saxon settlement was also located 1.5km north-east of the site at Orsett Cock.
- 1.4.13 A dense pattern of pits of varying size and shape are dispersed across the Orsett Cropmark Complex (Aerial Investigation and Mapping Report, sites 13-14) located 1km north-west of the site. Some of the pits are elongated in shape and these are thought likely to represent Saxon sunken-featured buildings (Place Services 2019). However, excavations directly to the south of the monument indicated that some of these features identified as pits by cropmark interpretation were of geological origin (Wilkinson 1988, 13-17). Saxon artefacts were however recorded in some features, demonstrating that there may have been a Saxon settlement in the vicinity.
- 1.4.14 Some of the discrete features identified from cropmarks within the site are also of similar size to sunken- featured buildings, but these too may also prove to be geological, or alternatively, as the 'pits' are of a variety of sizes and shapes, some rather irregular, many may prove to be small quarries of medieval or later date.
- 1.4.15 In the late Saxon and later medieval period the site was located within the parish of Orsett. The nucleated medieval settlement of Orsett was located 1km north-east of the site. It is likely that in the later medieval period the site was used as agricultural land associated with this settlement. A number of roughly north-south aligned droeways have been observed as cropmarks within the wider area and these may have been used to take livestock to and from the marshland to the upland ridge.

- 1.4.16 **Post-medieval period.** Documentary evidence indicates that the site was situated just to the south of an NE-SW road from Stifford to Stanford. It was also located east of a NNW-SSE aligned road from the hamlet of Baker Street to Chadwell St Mary. The 1805 First Edition OS map indicates that there may have been several houses along the Chadwell road, just west of the site. The Grade II listed 18th-century Whitecrofts Farmhouse is located immediately east of the site.
- 1.4.17 In the post-medieval period the site was likely to have been used as agricultural land just north of Orsett Heath. A NNW-SSE and a NE-SW aligned linear were identified by the aerial survey within the site. These are both regular and are in alignment or perpendicular with the post-medieval roads to the north and west of the site. A NNW-SSE aligned linear field boundary is shown on the c 1840 Orsett Tithe map (D/CT 264/1a) in roughly the same position as the cropmark and it is therefore likely that both of these linear features are post-medieval field boundaries.
- 1.4.18 **Undated features and cropmarks.** The site contains a large number of cropmark pit-like features of an unknown date and function across an extensive area. It is unclear if these are true archaeological features or if they are of geological origin. The site also contains a NW-SE aligned linear which is not as regular as the possible medieval or post-medieval field boundaries discussed above (Fig. 2). These features were identified by the aerial survey report (Aerial Investigation and Mapping Report site 21).
- 1.4.19 Undated cropmarks have also been identified 0.2km west of the site including enclosures, linears, large sub-circular pits and a ring-ditch (Aerial Investigation and Mapping Report site 23).



## 2 Project Aims

---

### 2.1 General aims

- 2.1.1 The general project aims of the project were as follows:
- 2.1.2 To establish the presence or absence of archaeological remains along the line of the scheme, and the extent of any areas where remains appear likely to be absent;
- 2.1.3 In areas where archaeological remains are known or suspected, to clarify the reliability of the cropmark or geophysical survey evidence;
- 2.1.4 In areas where no archaeological remains are indicated by aerial or geophysical survey, to clarify whether this apparent absence of remains is genuine;
- 2.1.5 To determine the degree of complexity of any surviving horizontal or vertical stratigraphy, and in particular, to investigate areas where topography indicates the likelihood of deep deposit sequences for evidence of buried archaeological horizons and palaeo-environmental sequences;
- 2.1.6 Where remains are present, to determine the period(s) represented, the extent, state of preservation and character of the archaeological remains;
- 2.1.7 To establish the range and state of preservation of archaeological artefacts, and through their recovery and examination, to establish the potential for information about the economy, status and contacts of past inhabitants of the scheme footprint;
- 2.1.8 To determine whether palaeo-environmental remains are preserved, and, where these are found, to determine their types (eg charred plant remains, waterlogged remains, molluscan remains), state of preservation and potential for environmental information. This will be achieved through the recovery of samples from sedimentary sequences and archaeological features suitable for assessment of a range of palaeoenvironmental remains (eg charred and waterlogged plant remains, charcoal, insects, pollen, diatoms, ostracods/foraminifera and molluscs) and scientific dating (eg radiocarbon and OSL dating);
- 2.1.9 To investigate and record the extent, character and chronology of the sedimentary sequences, in particular those immediately adjacent to and in floodplains, contained within palaeochannels or in dry valleys, and to use the data to refine existing geoarchaeological (predictive) deposit models.
- 2.1.10 To place any identified archaeological remains into their local and, where appropriate, regional or national context, and to assess the implications of any such discoveries for our current understanding of settlement and landscape change in the area, including an assessment of the associations of any remains with reference to the historic landscape;
- 2.1.11 To provide sufficient information to enable the LTC archaeological advisor, in consultation with the Key Archaeological Stakeholders, to determine the significance of the archaeological assets identified within the land parcel;

- 2.1.12 To provide a report on the discoveries to inform the Environmental Statement (ES) supporting the Development Consent Order (DCO) and support the preparation of a further archaeological mitigation strategy for the Enabling Works and Construction phases of the scheme;
- 2.1.13 Following the DCO, to deposit the report in the public domain, and to generate an accessible and useable archive which will allow future research of the evidence to be undertaken.

## 2.2 Specific objectives

- 2.2.1 The specific project objectives were as follows:
- 2.2.2 To conduct the programme of archaeological investigation within the general research parameters and objectives defined by the revised East of England Research Framework (Medlycott 2011), and to take account of the aims and objectives of the Greater Thames Estuary Historic Environment Research Framework.
- 2.2.3 To clarify through targeting of apparently blank areas whether the cropmarks provide an accurate representation of the range, quantity and types of archaeological features present within the parcel;
- 2.2.4 To investigate activity carried out around burial monuments of the Neolithic and early Bronze Age, whether peripheral burial, deposits related to visits, or reuse for burial or other purposes in later periods.
- 2.2.5 To clarify whether the circular ring-ditches scattered along the scheme are the remains of burial monuments or 'shrines' of the Bronze Age, and if so, to establish their date and duration of use within and beyond the period.
- 2.2.6 To look for evidence of early Bronze Age settlement or other activity in the vicinity of burial monuments or 'shrines'.
- 2.2.7 To further clarify the density and range of sites of the later Bronze Age within the scheme corridor, and to use both artefactual and scientific dating to assist in establishing whether occupation was long-lasting, repeated or shifting.
- 2.2.8 To clarify whether the predominance of early and late Iron Age activity currently apparent within the scheme area is genuine, or whether sites of middle Iron Age date are equally common.
- 2.2.9 To establish the extent, character and density of Roman activity within the scheme area, and in particular, whether the undated cropmark enclosures are Roman, and if so, establish their duration of use.
- 2.2.10 To determine whether further evidence of pottery production is present within the scheme area, and if so, to date and characterise this.
- 2.2.11 To establish the character and date of the extensive pits across the land parcel, and to determine whether these are all of one type or period, or whether they encompass several types and span several periods of activity;
- 2.2.12 To clarify the extent and character of the Saxon activity around that found on the A13 at Orsett Cock, and clarify the date and development of this within the Saxon period, and its relationship to the middle Saxon burials found at the causewayed enclosure site to the south.

- 2.2.13 To establish the date of the possible medieval or post-medieval field boundaries that have been identified within the land parcel;
- 2.2.14 To establish whether a possible medieval droveways extend northwards through the land parcel;
- 2.2.15 To look for evidence of medieval and post-medieval farmsteads which may have been located along the roadways within the northern and western part of the land parcel.

## 3 Methodology

---

### 3.1 Constraints

- 3.1.1 Overhead power lines limited the area of the site available for trial trenching. These comprised three parallel WNW-ESE aligned overhead lines which bisected the south-western corner of the site. There was also an overhead power line which ran along the southern edge of the site.
- 3.1.2 These limitations were taken into account when designing the detailed trench layout.

### 3.2 Methodology for the evaluation

- 3.2.1 The total land parcel area was 8.43ha, and the area available for investigation excluding areas of services, hedgerows and other constraints was 7.60 ha. The archaeological trial trenching comprised a total of 49 trenches, with 45 trenches measuring 30m x 2m, three trenches (Trenches 6, 7 and 49) measuring 20m x 2m and one trench (Trench 33) measuring 15m x 8m. Combined, these represent a 3.86% sample of the area available for trenching. The location of the trenches is shown on Figure 2.
- 3.2.2 The trench design was developed to target cropmark features identified by the aerial investigation and mapping report (Place Services 2019), and otherwise to provide even coverage of the blank areas. Trenches 9, 15, 26, 27, 32, 39, 43 and 45 targeted linear cropmark features. Trenches 4, 5, 6, 7, 8, 15, 24, 33, 36, 46 48 and 49 targeted possible discrete (Fig. 2).
- 3.2.3 All trenches were located using a Global Positioning System (GPS) prior to machine excavation. All trenches were excavated using a tracked excavator fitted with a toothless bucket under constant archaeological supervision.
- 3.2.4 Revealed features were hand cleaned and sampled by hand excavation. They were recording as outlined with the approved WSI. All finds were bagged by context throughout the evaluation and were recovered for further investigation.

## 4 Results

---

### 4.1 Introduction and presentation of results

- 4.1.1 The results of the evaluation are presented below, and include a stratigraphic description of the trenches that contained archaeological remains. The full details of all trenches with dimensions and depths of all deposits can be found in Appendix A. Finds data are tabulated in Appendix B.
- 4.1.2 Context numbers reflect the trench numbers unless otherwise stated, for example pit 102 is a cut within Trench 1, while ditch 304 is a cut within Trench 3.
- 4.1.3 An overview of the results for the site is shown on Figure 2. Further detailed plans of the trenches which contained archaeological features are shown on Figures 3-7 and selected sections are shown on Figures 8 and 9.

### 4.2 General soils and ground conditions

- 4.2.1 The soil sequence varied across the site with a natural geology of silty sand and silty clay across the southern half of the site and a silty clay with patches of gravel across the northern part of the site. A nearby borehole from the British Geological Survey along the A1089 (TQ68SW81 at 563710, 180200) indicates that the Boyn Hill Sand and Gravel extends c 4.5m below the surface in this area. This suggests that only the surface geology of Boyn Hill Sand and Gravel was encountered during this evaluation. The variation in the geology may have been influenced by the Lambeth Gravels which underlie the northern part of the site and the Thanet Sand which underlies the southern part of the site.
- 4.2.2 A thin subsoil layer (c 0.15m thick) of grey brown silty clay was encountered in Trenches 13, 23, 24, 25, 30, 31, 35, 36 in the central and northern part of the site. This is likely to be the relict remains of a former plough soil which now lies below the depth of the modern ploughing.
- 4.2.3 The topsoil was a dark grey brown silty clay or silty sand which was 0.28-0.5m thick.
- 4.2.4 Ground conditions throughout the evaluation were generally good, and the site remained dry throughout. Archaeological features, where present, were relatively easy to identify against the underlying geology. Several silty areas identified within the trenches were investigated and proved to be of natural origin.

### 4.3 General distribution of archaeological deposits

- 4.3.1 Archaeological features were located in Trenches 3, 5, 6, 20, 21, 22, 26, 27, 28, 29, 38, 40, 43, and 47. Two trenches (Trench 28 and 40) had three features (2803, 4002 and 4004) that contained pottery which dates to the late Bronze Age. These features were located within the north-western part of the site.

- 4.3.2 The evaluation confirmed the presence of several linear features within the site, which had been identified as cropmarks by the aerial investigation and mapping report (Place Services 2019). The features included 2603, 2704, 4302 and possibly 2003. These are discussed in more detail below.

## **4.4 Trench 3**

- 4.4.1 An area of possible modern disturbance (305) was recorded in the centre of the trench. This feature was sub-circular and was 0.68m in diameter and 0.11m deep. It contained dark grey silty sand which was similar to the topsoil. This feature is likely to be relatively recent in date.
- 4.4.2 A natural feature (303) was also recorded.

## **4.5 Trench 5**

- 4.5.1 Trench 5 contained a treehole (502) at the northern end of the trench. This was sub-circular and was 0.64m in diameter and 0.28m deep. It contained a single sterile fill.

## **4.6 Trench 6**

- 4.6.1 Trench 6 contained two sub-circular postholes at the northern end of the trench (602 and 604) (Fig. 3). The postholes were of similar dimensions and both contained single sterile grey brown silty sandy fills.

## **4.7 Trench 20**

- 4.7.1 Trench 20 contained a NW-SE aligned ditch (2003) at the western end of the trench (Figs 4 and 8 Section 2000). The ditch had a well-defined profile and was 0.86m wide and 0.16m deep. It contained two sterile fills (2004 and 2005).
- 4.7.2 It is possible that ditch 2003 represents the northern continuation of a linear cropmark identified to the west. This suggests a placement error margin of 9m for the cropmark, although it should be noted that the larger linear cropmarks to the west (Trenches 26 and 43) correlate exactly to identified features.

## **4.8 Trench 21**

- 4.8.1 Trench 21 contained a NE-SW aligned ditch (2102) at the southern end of the trench (Figs 4 and 8 Section 2100; Plate 1). The ditch was 0.67m wide and 0.14m deep and was U-shaped in profile. It contained a single fill (2103) that yielded a worked flint flake.

## **4.9 Trench 22**

- 4.9.1 Trench 22 contained three features: two possible pits (2203 and 2005) and a gully (2207) (Fig. 4).

- 4.9.2 Gully 2207 was located within the eastern end of the trench and was curvilinear in plan and aligned roughly NW-SE. The gully was 0.37m wide and 0.14m deep with a steeply sloped side and a flat base (Fig. 8 Section 2201). It contained one fill (2208) comprising a dark brown sandy silt with occasional stone and flint and occasional pieces of charcoal. This gully was truncated on its eastern side by a possible pit (2005) which was 0.78m wide and 0.19m deep with moderately steep side and a concave base. The pit contained a single sterile grey sand silt fill (2206).
- 4.9.3 A further possible pit (2203) was recorded in the centre of the trench. It contained a single grey brown silty sterile fill (2204).

## 4.10 Trench 26

- 4.10.1 Trench 26 contained a ditch (2603) which was aligned NNW-SSE and was 1.25m wide and 0.30m deep (Figs 5 and 8 Section 2601; Plate 2). The ditch contained a single homogeneous grey brown silty sand fill (2604).
- 4.10.2 This ditch matches the alignment and position of a linear cropmark which was recorded at this location by the aerial investigation and mapping report (Figs 2 and 5).

## 4.11 Trench 27

- 4.11.1 Trench 27 contained a pit (2702) at the southern end and a ditch at the northern end (2704) (Fig. 5).
- 4.11.2 Pit 2702 was 1.68m wide and 0.21m deep. It had concave sides and a flat base and contained a single sterile silty sandy fill (2703).
- 4.11.3 Ditch 2704 at the northern end of the trench was aligned NE-SW and was 1.34m wide and 0.43m deep with a flat base and moderately steep sides (Fig. 8 Section 2701; Plate 3). The ditch contained one fill (2705), a brown grey silty sand. As with ditch 2603 in nearby Trench 26, ditch 2704 appeared to match the alignment and position of a linear cropmark which was recorded at this location by the aerial investigation and mapping report (Figs 2 and 5).

## 4.12 Trench 28

- 4.12.1 Trench 28 contained a posthole (2803) in the centre of the trench which was sub-circular in plan and 0.24m diameter (Fig. 6). The posthole had steep sides and a U-shaped base and was 0.21m deep (Fig. 9 Section 2800; Plate 4). The posthole contained a single grey silty clay fill (2804) which yielded three small sherds of Bronze Age pottery.

## 4.13 Trench 29

- 4.13.1 Trench 29 contained a pit (2903) in the southern half of the trench (Fig. 6) which was 1m in diameter and 0.38m deep with moderately steep sides and a concave base. The pit contained a single sterile fill (2904)

## 4.14 Trench 33

- 4.14.1 Trench 33 contained several amorphous patches of gravel 2-3m wide, which included large pebbles up to c 100mm in diameter. These features were of natural origin. These features are the likely origin of the sub-oval cropmarks that were identified in this area.

## 4.15 Trench 38

- 4.15.1 Trench 38 contained a pit (3803) in the southern part of the trench which extended eastwards into the bulk of the trench (Fig. 7). The visible part of the pit was 0.36m wide and 0.13m deep with a shallow western side and a concave base (Fig. 9 Section 3800; Plate 5). The pit contained one fill (3802), a brown silty sand with frequent pieces of charcoal and small stones.
- 4.15.2 An environmental sample (1) was taken from fill 3802. This yielded charcoal and clinker-like material which could not be identified further. No other plant remains were identified in the flot.

## 4.16 Trench 40

- 4.16.1 Trench 40 contained two features, pit 4002 within the northern end of the trench and ditch 4004 within the southern end (Fig. 6).
- 4.16.2 Pit 4002 was circular in plan and measured 0.70m in diameter and 0.09m deep. The pit contained a single dark grey silty sand fill (4003) with some gravel inclusions (Fig. 9 Section 4000). This deposit produced 30 sherds of Bronze Age pottery and one small fragment of unworked burnt flint.
- 4.16.3 Ditch 4004 was aligned NE-SW and was 0.55m wide and 0.19m deep with a well-defined U-shaped profile (Fig. 9 Section 4001; Plate 6). The ditch contained a single brown silty clay fill (4005) yielding eight small sherds of Bronze Age pottery.

## 4.17 Trench 43

- 4.17.1 Trench 43 contained a NW-SE aligned ditch (4302) within the southern end of the trench (Fig. 7). The ditch was 1.2m wide and 0.36m deep with moderately steep sides and a concave base (Fig. 9 Section 4300). This contained two fills, a lower fill of grey brown silty sand (4303) and an upper fill of yellow brown silty sand (4304).
- 4.17.2 This ditch closely matches the alignment and position of a linear cropmark which was recorded at this location by the aerial investigation and mapping report (Figs 2 and 7). There was no sign of the NE-SW aligned linear in the northern part of the trench as suggested by the aerial investigation and mapping report.

## 4.18 Trench 47

- 4.18.1 Trench 47 contained four features: a linear feature (4702), a sub-oval feature (4704) and two amorphous features (4706 and 4708). The two amorphous features in the southern end of the trench were sampled and identified as natural features and were not excavated in greater detail (Fig.2).



- 4.18.2 The sub-oval feature (4704) in the northern part of the trench was 0.84m in diameter and 0.23m deep with a U-shaped profile. This feature contained one sterile fill (4705), a friable red brown sandy silt with fine gravel inclusions. The fill (4703) was very similar to the surrounding geology but with finer gravels and was therefore thought that 4704 was a natural geological feature.
- 4.18.3 The linear feature in the centre of the trench (4702) was aligned ENE-WSW and had a gentle slope on the eastern side and a steeper slope on the western side and a concave shaped base. It contained one fill (4703), an orange brown silt sand with occasional pebbles. The section indicated darker areas of vertical bioturbation and darker patches of straining on the sides of the excavated feature which is perhaps suggestive of rooting. On this basis it is possible that this feature could be the relict remains of a former hedgerow.

## 4.19 Finds summary

- 4.19.1 **Late Bronze Age pottery.** Three contexts produced 41 sherds of pottery weighing 203g, comprising 30 sherds (163g) within 4003, eight sherds (25g) in 4005 and three sherds (15g) in 2804. All the pottery could belong to the same period and are probably late Bronze Age, but could also conceivably belong to the early or middle Iron Age periods. In addition, one vessel in context 4003 had a pinched cordon which is an uncommon feature of late Bronze Age and early/middle Iron Age assemblages.
- 4.19.2 **Worked flint.** A small assemblage of four struck flints and a single fragment of burnt unworked flint weighing 3g was recovered from five contexts (1400, 2103, 2300, 3600 and 4003). Three of the pieces of worked flint were recovered from the topsoil (1400, 2300 and 3600), one flake was found in ditch 2102, and one piece of unworked burn flint came from pit 4002.
- 4.19.3 None of the worked flint is closely dateable.

## 4.20 Environmental summary

One sample was taken from fill 3802 of pit 3803 which produced charcoal and clinker-like material. The charcoal was not identifiable to species. No other plant remains were identified in the flot.

## 5 Discussion

---

### 5.1 Reliability of field investigation

- 5.1.1 The archaeological features were reasonably well defined against the underlying Boyn Hill Gravel, although several deposits were sample excavated to establish if they were of geological or archaeological significance. In all examples, the features confirmed the initial interpretations.
- 5.1.2 There was a correlation between the aerial survey cropmarks and the archaeological features in Trenches 26, 27 and 43. This included linear features cropmarks 2603, 2704 and 4302. The NNW-SSE linear found in Trench 43 was also looked for in Trench 15 and 39 but was not identified. The NE-SW linear in Trench 43 and the NNW-SSE linear in Trench 9 were also not identified. Where linear features were identified (2603, 2704 and 4302), they were only 0.30-0.43m deep. It is therefore possible that evidence of these ditches within Trenches 15 and 39 has been truncated by ploughing, as the site is in use as an arable field. The aerial photos that were sourced for plotting the cropmarks on the site were dated 1972 and 1982 (MEX18160). It is conceivable that modern ploughing may have truncated parts of these features in the 30-40 years since the aerial photographs were taken.
- 5.1.3 The discrete features identified as cropmarks in Trenches 4, 5, 6, 7, 8, 15, 24, 33, 36, 46 48 and 49 were not identified during the excavation, with the exception of the gravel patches in Trench 33. It is likely that the discrete features in the other trenches were all natural features and this possibility is discussed further below in Section 5.2.
- 5.1.4 The north-western part of the site contained previously unidentified areas of sparse archaeological features in Trenches 27, 28, 29 and 40, three of which contained late Bronze Age pottery (2803, 4002 and 4004). The eastern part of the site also contained several archaeological features in Trenches 20, 21 and 22 and one Trench (6) in the south-western part of the site which contained two postholes. It is likely that the absence of archaeological remains in the north-eastern and south-eastern part of the site reflects an absence of archaeological activity in these areas.

### 5.2 Interpretation

- 5.2.1 **Mesolithic/Neolithic.** Four worked flints were found across the site although only one within could be dated, an edge retouch preparation blade within topsoil 1400. This blade was tentatively dated to the early Neolithic but could also be Mesolithic in date. Neolithic activity is known nearby, including an early Neolithic causewayed enclosure located 1km east of the site, several Neolithic finds in the area and a possible mortuary enclosure 40m from the south-east corner of the site.

- 5.2.2 The presence of flint artefacts in low concentrations is a common feature of swathes of landscape where there is surrounding prehistoric activity and this does not necessarily reflect the presence of significant archaeological features or deposits at these locations.
- 5.2.3 **Late Bronze Age.** Three features were tentatively dated to the late Bronze Age in the north-western part of the site. This includes posthole 2803, pit 4002 and NE-SW aligned ditch 4004. These contained late Bronze Age pottery, although it is possible that the pottery could date to the early Iron Age. One of the vessels within context 4003 had a pinched cordon which is unusual but consistent with late Bronze Age and early/middle Iron Age assemblages.
- 5.2.4 In the wider area there are several examples of late Bronze Age to early Iron Age settlements. The nearest was excavated at Baker Street during the A13 excavations, located c 600m north-west of the site. That excavation recorded several late Bronze Age to early Iron Age features, including pits, a gully and eight postholes, which may have formed an oval building (Wilkinson 1988, 15-16).
- 5.2.5 **Post-medieval.** The NNW-SSE-aligned cropmark which bisects the western part of the site is very likely the same linear field boundary shown on the c 1840 Orsett Tithe map (D/CT 264/1a). This field boundary divided two fields west of the Grade II listed (1111566) farmhouse known as Heathers (later Whitecrofts Farmhouse), which was constructed in the 18th century.
- 5.2.6 Ditches 2603 and 4302 in Trenches 26 and 43 are undated but they match the alignment and position of the NNW-SSE cropmark and also the field boundary shown on the 1840 Orsett Tithe map (Fig. 2). This suggests that these ditches are very likely post-medieval in date. The NNE-SSW linear cropmark to the west of the site was confirmed by ditch 2704 and this may also be post-medieval in date, although perhaps pre-dating the 1840 Orsett Tithe map. These field boundaries are not shown on the OS first edition of 1873 and therefore they are likely to have been removed prior to this date.
- 5.2.7 **Undated.** A number of undated archaeological features were identified within Trenches 6, 20, 21, 22, 27, 29 and 38. This includes two postholes (602, 604), a NW-SE aligned ditch (2003), a NE-SW aligned ditch (2102), a NW-SE aligned gully (2207) and four pits (2203, 2702, 2903, 3803). These features do not appear to reflect any discernible pattern of activity and the absence of artefacts and obvious environmental evidence suggests that they are not closely associated with settlements.
- 5.2.8 **Natural features.** The possible relict ENE-WSW hedgerow 4702 in Trench 47 is on a similar alignment to the Stifford-Stanford Road to the north. This hedgerow may have been an additional field boundary, removed prior to the mid 19th century.

- 5.2.9 **Geological features.** The site contained a large number of discrete sub-circular features 1-3m in diameter which were identified as cropmarks and were targeted in Trenches 4, 5, 6, 7, 8, 15, 24, 33, 36, 46 48 and 49. Several amorphous gravel patches were identified within Trench 33 and these may be the same features identified as discrete cropmark features by the aerial survey. The rest of the discrete features were not identified but natural features were identified and excavated within Trenches 3, 44 and 47.
- 5.2.10 There appears to have been two types of geological features identified on the site as indicated by Trenches 3, 33, 44 and 47. One type of natural feature was identified in Trench 33 which were patches of natural gravels 1-3m wide. This could be a variation in the natural superficial geology of Boyn Hill gravels. The other type of natural feature was identified in Trenches 3, 44 and 47. These features were sub-circular, 0.7-0.9m indiameter, and contained more finely sorted silty sand than the surrounding more gravelly natural geology. It is possible that these features are periglacial features and could be comparable to the geological features that were identified during the Baker Street excavation as part of the A13 widening scheme, located c 600m north-west of the site. This excavation took place just south of the Orsett Cropmark Complex (1002134) which contains a dense pattern of pits of varying size and shape. The Baker Street excavation identified a number of circular features 3-4m diameter and these were tentatively thought to be periglacial non-sorted or ice wedge polygons (Wilkinson 1980, 15).

### 5.3 Evaluation objectives and results

- 5.3.1 This evaluation established the presence of archaeological remains and investigated their character by analysing artefacts and environmental evidence. The evaluation also ground-truthed the cropmark evidence as identified by the 2019 aerial survey (Place Services 2019). The evaluation also investigated the apparently blank areas where no cropmarks had been identified.
- 5.3.2 The archaeological evaluation conducted the investigation within the general research parameters and objectives defined by the revised East of England Research Framework (Medlycott 2011), and to took account of the aims and objectives of the Greater Thames Estuary Historic Environment Research Framework.
- 5.3.3 In terms of specific objectives, the evaluation did not find any evidence of burial monuments of the Neolithic and early Bronze Age date within the site.
- 5.3.4 The evaluation did establish a low level of Bronze Age activity with three features in the north-western part (posthole 2803, pit 4002 and NE-SW aligned ditch 4004). It is possible that the pottery within these features could be slightly later (early to mid-Iron Age).
- 5.3.5 The evaluation did not find any evidence of any Roman, Saxon or medieval activity on the site.

- 5.3.6 The extensive number of pits identified as cropmarks within the south and eastern part of the site are clearly of geological origin. Two types of geological feature were identified across the site, including patches of gravel (Trench 33) or areas of finely sorted silty sand (Trenches 3, 44 and 47). The exact process which formed these features is not confirmed although several of these features may be due to the variation in the Boyn Hill sand and gravels.
- 5.3.7 The NNW-SSE field boundary as recorded as a cropmark and by ditches 2603 and 4302 is very likely the same field boundary as shown on the 1840 Orsett Tithe map. This suggests that ditches 2603 and 4302 are post-medieval in date. Ditch 2704 may also be post-medieval in date and appears to relate to the same system of field division as 2603 and 4302.
- 5.3.8 No evidence of medieval droveways or medieval and post-medieval farmsteads were identified within the site.

## Appendix A Trench Tables

Trench 1							
General description						Orientation	NE-SW
Trench devoid of archaeology. Consists of topsoil overlying natural geology.						Length (m)	30
						Width (m)	2
						Avg. depth (m)	0.57
Ctxt No.	Type	Fill Of	Width (m)	Depth (m)	Description	Finds	Date
100	Layer			0.48	Topsoil. Mid grey brown, silty sand, friable		
101	Layer				Natural. Mid orange brown, silty sand with gravel patches		

Trench 2							
General description						Orientation	
Trench devoid of archaeology. Consists of topsoil overlying natural geology.						Length (m)	
						Width (m)	
						Avg. depth (m)	
Ctxt No.	Type	Fill Of	Width (m)	Depth (m)	Description	Finds	Date
200	Layer			0.32	Ploughsoil. Dark greyish brown, silty clay		
201	Layer				Natural. Mid orange brown, silty sand with gravel patches		

Trench 3							
General description						Orientation	N-S
Trench contained a single natural feature and a pit, likely to be modern disturbance. The natural geology was overlain by subsoil and topsoil layers.						Length (m)	30
						Width (m)	2.1
						Avg. depth (m)	0.47
Ctxt No.	Type	Fill Of	Width (m)	Depth (m)	Description	Finds	Date
300	Layer			0.35	Ploughsoil. Mid brown grey clay silt		
301	Layer			0.15	Subsoil. Mid grey brown silt clay		
302	Layer				Natural. Mid red brown sand and gravel		
303	Cut		0.9	0.13	Natural Feature		
304	Fill	303		0.13	Secondary Fill. Mid grey brown silty sand formed by natural processes		
305	Cut		0.68	0.12	Modern		
306	Fill	305		0.12	Deliberate Backfill. Dark brown grey silt sand, backfill of modern disturbance		

Trench 4							
General description						Orientation	E-W
Trench devoid of archaeology. Consists of topsoil and subsoil overlying natural geology.						Length (m)	30
						Width (m)	2.1
						Avg. depth (m)	0.34
Ctxt No.	Type	Fill Of	Width (m)	Depth (m)	Description	Finds	Date
400	Layer			0.34	Ploughsoil. Mid greyish-brown, silty sand		
401	Layer				Natural. Mid orange brown, silty sand		

Trench 5							
General description						Orientation	NW-SE
Trench contained possible postholes and pits. The natural geology was overlain by topsoil						Length (m)	30
						Width (m)	2
						Avg. depth (m)	0.34
Ctxt No.	Type	Fill Of	Width (m)	Depth (m)	Description	Finds	Date
500	Layer			0.34	Ploughsoil. Dark grey brown, silty clay		
501	Layer				Natural. Light orangey/yellow brown, silty sand with gravel patches		
502	Cut		1	0.28	Natural Feature. Tree throw		
503	Fill	502	1	0.28	Primary Fill. Light greyish brown, sandy silt		

Trench 6							
General description						Orientation	N-S
Trench contained two possible postholes. The natural geology was overlain by topsoil						Length (m)	20
						Width (m)	2
						Avg. depth (m)	0.32
Ctxt No.	Type	Fill Of	Width (m)	Depth (m)	Description	Finds	Date
600	Layer			0.32	Ploughsoil. Dark grey brown, silty clay		
601	Layer				Natural. Light orangey/yellow silty sand and gravel		
602	Cut		0.45	0.24	Posthole. Possible posthole		
603	Fill	602	0.45	0.24	Primary Fill. Mid grey brown, silty sand with gravel inclusions		
604	Cut		0.35	0.18	Posthole. Possible posthole		
605	Fill	604	0.35	0.18	Primary Fill. Mid grey brown, silty sand with gravel inclusions		

<b>Trench 7</b>							
General description						Orientation	E-W
Trench devoid of archaeology. Consists of topsoil overlying natural geology.						Length (m)	20
						Width (m)	2
						Avg. depth (m)	0.31
Ctxt No.	Type	Fill Of	Width (m)	Depth (m)	Description	Finds	Date
700	Layer			0.31	Ploughsoil. Dark grey brown, silty clay		
701	Layer				Natural. Light orangey/yellow brown, silt sand with gravel patches. Plough scars contamination		

<b>Trench 8</b>							
General description						Orientation	E-W
Trench devoid of archaeology. Consists of topsoil overlying natural geology						Length (m)	30
						Width (m)	2.1
						Avg. depth (m)	0.43
Ctxt No.	Type	Fill Of	Width (m)	Depth (m)	Description	Finds	Date
800	Layer			0.39	Ploughsoil. Dark greyish brown, silty sand		
801	Layer				Natural. Mid greyish brown, silty sand with gravel patches		

<b>Trench 9</b>							
General description						Orientation	NE-SW
Trench devoid of archaeology. Consists of ploughsoil overlying natural geology						Length (m)	30
						Width (m)	2.1
						Avg. depth (m)	0.48
Ctxt No.	Type	Fill Of	Width (m)	Depth (m)	Description	Finds	Date
900	Layer			0.35	Ploughsoil. Mid greyish-brown, silty clay		
901	Layer				Natural. Mid orange brown, sand and gravel		



<b>Trench 10</b>							
General description						Orientation	NW/S E
Trench devoid of archaeology. Consists of topsoil overlying natural geology.						Length (m)	30
						Width (m)	2
						Avg. depth (m)	0.36
Ctxt No.	Type	Fill Of	Width (m)	Depth (m)	Description	Finds	Date
1000	Layer			0.35	Topsoil. Dark grey brown, silt sand, friable		
1001	Layer				Natural. Mid orange brown, silty with large gravel patches, friable		

<b>Trench 11</b>							
General description						Orientation	E-w
Trench devoid of archaeology. Consists of topsoil overlying natural geology.						Length (m)	30
						Width (m)	2.1
						Avg. depth (m)	0.39
Ctxt No.	Type	Fill Of	Width (m)	Depth (m)	Description	Finds	Date
1100	Layer			0.39	Ploughsoil. Dark greyish-brown, silty sand		
1101	Layer				Natural. Mid orange -brown, silty sand with some gravel patches		

<b>Trench 12</b>							
General description						Orientation	NW- SE
Trench devoid of archaeology. Consists of ploughsoil overlying natural geology.						Length (m)	30
						Width (m)	2.1
						Avg. depth (m)	0.44
Ctxt No.	Type	Fill Of	Width (m)	Depth (m)	Description	Finds	Date
1200	Layer			0.28	Ploughsoil. Dark grey brown, silty clay		
1201	Layer				Natural. Mid orange brown, silty sand with fine gravels		

<b>Trench 13</b>							
General description						Orientation	NE-SW
Trench devoid of archaeology. Consisted of topsoil and subsoil overlying natural geology.						Length (m)	30
						Width (m)	2.1
						Avg. depth (m)	0.43
Ctxt No.	Type	Fill Of	Width (m)	Depth (m)	Description	Finds	Date
1300	Layer			0.29	Ploughsoil. Mid brown grey silt clay		
1301	Layer			0.14	Subsoil. Mid grey brown silt clay		
1302	Layer				Natural. Mid red brown sand and gravel		

<b>Trench 14</b>							
General description						Orientation	NW-SE
Trench devoid of archaeology. Consists of ploughsoil overlying natural geology.						Length (m)	30
						Width (m)	2.1
						Avg. depth (m)	0.46
Ctxt No.	Type	Fill Of	Width (m)	Depth (m)	Description	Finds	Date
1400	Layer			0.33	Ploughsoil. Mid greyish-brown, silty clay		
1401	Layer				Natural. Mid orange brown, silty sand and gravel		

<b>Trench 15</b>							
General description						Orientation	E-W
Trench devoid of archaeology. Consists of topsoil overlying natural geology.						Length (m)	30
						Width (m)	2.1
						Avg. depth (m)	0.36
Ctxt No.	Type	Fill Of	Width (m)	Depth (m)	Description	Finds	Date
1500	Layer			0.32	Ploughsoil. Dark grey brown, silty clay		
1501	Layer				Natural. Mid orange brown, silty sand with gravel patches		

<b>Trench 16</b>							
General description						Orientation	NE-SW
Trench devoid of archaeology. Consists of topsoil overlying natural geology.						Length (m)	30
						Width (m)	2.1
						Avg. depth (m)	0.29
Ctxt No.	Type	Fill Of	Width (m)	Depth (m)	Description	Finds	Date
1600	Layer			0.29	Ploughsoil. Dark greyish-brown, silty sand		
1601	Layer				Natural. Mid yellowish brown, silty sand with gravel patches		

<b>Trench 17</b>							
General description						Orientation	N-S
Trench devoid of archaeology. Consists of topsoil and subsoil overlying natural geology.						Length (m)	30
						Width (m)	2.1
						Avg. depth (m)	0.34
Ctxt No.	Type	Fill Of	Width (m)	Depth (m)	Description	Finds	Date
1700	Layer			0.25	Ploughsoil. Dark grey brown, silty clay		
1701	Layer			0.09	Subsoil. Mid grey brown, silty clay		
1702	Layer				Natural. Mid orange brown, silty sand with gravel patches		

<b>Trench 18</b>							
General description						Orientation	NE-SW
Trench devoid of archaeology. Consists of topsoil and subsoil overlying the natural geology						Length (m)	30
						Width (m)	2.1
						Avg. depth (m)	0.42
Ctxt No.	Type	Fill Of	Width (m)	Depth (m)	Description	Finds	Date
1800	Layer			0.28	Ploughsoil. Dark greyish-brown, silty sand		
1801	Layer				Natural. Mid yellowish brown, silty sand with gravel patches		

<b>Trench 19</b>							
General description						Orientation	NW-SE
Trench devoid of archaeology. Consists of topsoil overlying natural geology.						Length (m)	30
						Width (m)	2.1
						Avg. depth (m)	0.47
Ctxt No.	Type	Fill Of	Width (m)	Depth (m)	Description	Finds	Date
1900	Layer			0.30	Ploughsoil. Dark greyish-brown, silty sand		
1901	Layer				Natural. Mid yellowish brown, silty sand with gravel patches		

<b>Trench 20</b>							
General description						Orientation	E-W
Trench contained one ditch. Consists of ploughsoil and subsoil overlying natural geology						Length (m)	30
						Width (m)	2.1
						Avg. depth (m)	0.49
Ctxt No.	Type	Fill Of	Width (m)	Depth (m)	Description	Finds	Date
2000	Layer			0.23	Ploughsoil. Dark grey brown, silty clay		
2001	Layer			0.13	Subsoil. Mid grey brown, silty clay		
2002	Layer				Natural. Mid orange brown, silty sand with gravel patches		
2003	Cut		0.86	0.16	Ditch		
2004	Fill	2003	0.86	0.13	Primary Fill. Mid greyish-brown, silty sand		
2005	Fill	2003	0.33	0.03	Secondary Fill. Light yellowish-brown, silty sand with shells inclusion		

<b>Trench 21</b>							
General description						Orientation	NW-SE
Trench revealed a single NE-SW aligned ditch at the southeast end. The natural geology was overlain by topsoil.						Length (m)	30
						Width (m)	2.1
						Avg. depth (m)	0.64
Ctxt No.	Type	Fill Of	Width (m)	Depth (m)	Description	Finds	Date
2100	Layer			0.34	Topsoil. Mid grey brown, silty clay		
2101	Layer				Natural. Mid orange brown, silty clay with gravel		
2102	Cut		0.67	0.14	Ditch. Linear, U-shaped base		
2103	Fill	2102	0.67	0.14	Secondary Fill. Mid grey brown, silty clay with infrequent fine gravel.		

Trench 22							
General description						Orientation	NE/S W
Trench revealed a Ditch/gully, with pit on edge near hedge line and a potential three throw. Consisted of ploughsoil overlying the natural geology						Length (m)	30
						Width (m)	2
						Avg. depth (m)	0.42
Ctxt No.	Type	Fill Of	Width (m)	Depth (m)	Description	Finds	Date
2200	Layer			0.3	Ploughsoil. Dark grey brown, silty clay		
2201	Layer			0.12	Subsoil. Mid grey brown, silty clay		
2202	Layer				Natural. Mid orange brown, silty sand with gravel patches		
2203	Cut		1.09	0.41	Pit		
2204	Fill	2203	1.09	0.41	Primary Fill. Mid grey brown, silty sand. No finds		
2205	Cut		0.78	0.19	Pit. Possible natural feature.		
2206	Fill	2205	0.78	0.19	Secondary Fill. Mid to dark brownish grey, sandy silt, no dating.		
2207	Cut		0.37	0.14	Ditch. Curvilinear feature		
2208	Fill	2207	0.37	0.14	Secondary Fill. Mid to dark brownish grey, sandy silt, no dating material,		

Trench 23							
General description						Orientation	NW- SE
Trench devoid of archaeology. Consists of topsoil and subsoil overlying natural geology.						Length (m)	30
						Width (m)	2
						Avg. depth (m)	0.44
Ctxt No.	Type	Fill Of	Width (m)	Depth (m)	Description	Finds	Date
2300	Layer			0.28	Ploughsoil. Dark grey brown, silty clay		
2301	Layer			0.14	Subsoil. Mid grey brown, silty clay		
2302	Layer				Natural. Mid orange brown, silty clay with gravel patches		

Trench 24							
General description						Orientation	NE- SW
Trench devoid of archaeology. Consists of topsoil and subsoil overlying natural geology.						Length (m)	30
						Width (m)	2
						Avg. depth (m)	0.5
Ctxt No.	Type	Fill Of	Width (m)	Depth (m)	Description	Finds	Date
2400	Layer			0.35	Ploughsoil. Dark grey brown, silty clay		

2401	Layer			0.15	Subsoil. Mid grey brown, silty clay		
2402	Layer				Natural. Mid orange brown, silty clay with gravel patches		

Trench 25							
General description						Orientation	NW-SE
Trench devoid of archaeology. Consists of topsoil and subsoil overlying natural geology.						Length (m)	30
						Width (m)	2
						Avg. depth (m)	0.47
Ctxt No.	Type	Fill Of	Width (m)	Depth (m)	Description	Finds	Date
2500	Layer			0.32	Ploughsoil. Dark grey brown, silty clay		
2501	Layer			0.11	Subsoil. Mid grey brown, silty clay		
2502	Layer				Natural. Mid orange brown, silty clay		

Trench 26							
General description						Orientation	E-W
Trench contained a single ditch. Consisted of ploughsoil overlying natural geology						Length (m)	30
						Width (m)	2
						Avg. depth (m)	0.43
Ctxt No.	Type	Fill Of	Width (m)	Depth (m)	Description	Finds	Date
2600	Layer			0.33	Ploughsoil. Dark brownish grey, silty sand		
2601	Layer			0.1	Subsoil. Mid greyish brown, silty sand		
2602	Layer				Natural. Mid orangey brown, silty sand and gravel		
2603	Cut		1.25	0.3	Ditch. Linear ditch N-S		
2604	Fill	2603	1.25	0.3	Primary Fill. Mid grey brown, silty sand. Single fill of ditch, no finds		

Trench 27							
General description						Orientation	N-S
Trench contained one ditch and one pit. Consisted of ploughsoil overlying the natural geology						Length (m)	30
						Width (m)	2.1
						Avg. depth (m)	0.42
Ctxt No.	Type	Fill Of	Width (m)	Depth (m)	Description	Finds	Date
2700	Layer			0.42	Ploughsoil. Dark greyish brown, silty sand		
2701	Layer				Natural. Mixed mid orange/yellowish brown, silty sand		

2702	Cut		1.68	0.21	Pit. Possible tree throw		
2703	Fill	2702	1.68	0.21	Primary Fill. Mid greyish brown, silty sand		
2704	Cut		1.34	0.43	Ditch. Boundary ditch		
2705	Fill	2704	1.34	0.43	Primary Fill. Dark brownish grey, silty sand		

<b>Trench 28</b>							
General description						Orientation	E-W
Trench contained a single posthole. Consists of ploughsoil overlying the natural geology						Length (m)	30
						Width (m)	2
						Avg. depth (m)	0.42
Ctxt No.	Type	Fill Of	Width (m)	Depth (m)	Description	Finds	Date
2800	Layer			0.34	Ploughsoil. Dark greyish brown, silty sand		
2801	Layer			0.08	Subsoil. Mid greyish brown, silty sand		
2802	Layer				Natural. Mid greyish brown, silty sand and gravel patches		
2803	Cut		0.24	0.21	Posthole		
2804	Fill	2803	0.24	0.21	Primary Fill. Mid brownish grey, silty sand. Single fill, pottery found		

<b>Trench 29</b>							
General description						Orientation	N-S
Trench contained a single pit. Consists of ploughsoil overlying the natural geology						Length (m)	30
						Width (m)	2
						Avg. depth (m)	0.38
Ctxt No.	Type	Fill Of	Width (m)	Depth (m)	Description	Finds	Date
2900	Layer			0.26	Topsoil. Mid to dark greyish brown slight yellowish, friable, sandy silt, small stone		
2901	Layer			0.13	Subsoil. Light yellowish brown, friable, sandy silt, numerous small to mid stone and flint		
2902	Layer				Natural. Light to mid reddish brown mottled yellowish, firmly friable, gravelly silt, abundant small to mid stone and flint		
2903	Cut		1	0.38	Pit steep sloping sides, moderately gentle break, concave base, no dating material, possibly refuse		
2904	Fill	2903	1	0.38	Secondaryfill, mid greyish brown slight yellowish, friable, sandy silt, natural silting, sterile		

<b>Trench 30</b>							
General description						Orientation	E-W
Trench devoid of archaeology. Consists of ploughsoil and subsoil covering natural geology						Length (m)	30
						Width (m)	2
						Avg. depth (m)	0.42
Ctxt No.	Type	Fill Of	Width (m)	Depth (m)	Description	Finds	Date
3000	Layer			0.31	Ploughsoil. Dark grey brown, silty clay		
3001	Layer			0.11	Subsoil. Mid greyish brown, clayey sand		
3002	Layer				Natural. Mid orangey/red brown, silty sand		

<b>Trench 31</b>							
General description						Orientation	NW-SE
Trench devoid of archaeology. Consists of topsoil and subsoil overlying natural geology.						Length (m)	30
						Width (m)	2
						Avg. depth (m)	0.49
Ctxt No.	Type	Fill Of	Width (m)	Depth (m)	Description	Finds	Date
3100	Layer			0.31	Ploughsoil. Dark grey brown, silty clay		
3101	Layer			0.16	Subsoil. Mid grey brown, silty clay		
3102	Layer				Natural. Mid orange brown, silty sand with gravel patches		

<b>Trench 32</b>							
General description						Orientation	E-W
Trench devoid of archaeology. Consists of topsoil overlying natural geology.						Length (m)	30
						Width (m)	2
						Avg. depth (m)	0.33
Ctxt No.	Type	Fill Of	Width (m)	Depth (m)	Description	Finds	Date
3200	Layer			0.28	Ploughsoil. Dark grey brown, silty clay		
3201	Layer				Natural. Mid orange brown, silty sand with gravel patches		



<b>Trench 33</b>							
General description						Orientation	NE/S W
Trench devoid of archaeology. Consists of topsoil and subsoil overlying natural geology. Several patches of gravels 1-3m diameter were identified in this trench – variations in natural.						Length (m)	15
						Width (m)	10
						Avg. depth (m)	0.3
Ctxt No.	Type	Fill Of	Width (m)	Depth (m)	Description	Finds	Date
3300	Layer			0.15	Topsoil. Dark grey brown, silty sand, friable		
3301	Layer				Natural. Mid orange brown, silty sand with gravel patches		

<b>Trench 34</b>							
General description						Orientation	N-S
Trench devoid of archaeology. Consists of topsoil and subsoil overlying natural geology.						Length (m)	30
						Width (m)	2
						Avg. depth (m)	0.35
Ctxt No.	Type	Fill Of	Width (m)	Depth (m)	Description	Finds	Date
3400	Layer			0.3	Ploughsoil. Dark grey brown, silty clay		
3401	Layer				Natural. Mid orange brown, silty sand with gravel patches		

<b>Trench 35</b>							
General description						Orientation	NW- SE
Trench devoid of archaeology and consisted of topsoil and subsoil overlying natural geology						Length (m)	30
						Width (m)	2.1
						Avg. depth (m)	0.43
Ctxt No.	Type	Fill Of	Width (m)	Depth (m)	Description	Finds	Date
3500	Layer			0.29	Ploughsoil. Dark grey brown, silty clay		
3501	Layer			0.11	Subsoil. Mid grey brown, silty clay		
3502	Layer				Natural. Mid orange brown, silty sand with gravel patches		

<b>Trench 36</b>							
General description						Orientation	NW-SE
Trench devoid of archaeology and consisted of topsoil and subsoil overlying the natural geology						Length (m)	30
						Width (m)	2.1
						Avg. depth (m)	0.42
Ctxt No.	Type	Fill Of	Width (m)	Depth (m)	Description	Finds	Date
3600	Layer			0.28	Ploughsoil. Dark grey brown, silty clay		
3601	Layer			0.14	Subsoil. Mid grey brown, silty clay		
3602	Layer				Natural. Mid orange brown, silty sand with gravel patches		

<b>Trench 37</b>							
General description						Orientation	E-W
Trench devoid of archaeology. Consists of topsoil and subsoil overlying natural geology.						Length (m)	30
						Width (m)	2
						Avg. depth (m)	0.34
Ctxt No.	Type	Fill Of	Width (m)	Depth (m)	Description	Finds	Date
3700	Layer			0.3	Ploughsoil. Mid brown grey silt clay		
3701	Layer			0.13	Subsoil. Mid grey brown silt clay		
3702	Layer				Natural. Mid red brown sand and gravels		

<b>Trench 38</b>							
General description						Orientation	N-S
Trench contains one pit. Consists of ploughsoil overlying natural geology						Length (m)	30
						Width (m)	2.1
						Avg. depth (m)	0.33
Ctxt No.	Type	Fill Of	Width (m)	Depth (m)	Description	Finds	Date
3800	Layer			0.3	Ploughsoil. Mid greyish brown silty sand, moderate stone		
3801	Layer				Natural. Light-mid reddish brown silty sand and gravel		
3802	Fill	3803	0.4	0.13	Secondary Fill. Soft dark brownish grey silty sand, frequent small stone and charcoal		
3803	Cut		0.4	0.13	Pit		

<b>Trench 39</b>							
General description						Orientation	NE-SW
Trench devoid of archaeology. Consists of topsoil overlying natural geology.						Length (m)	30
						Width (m)	2.1
						Avg. depth (m)	0.36
Ctxt No.	Type	Fill Of	Width (m)	Depth (m)	Description	Finds	Date
3900	Layer			0.36	Ploughsoil. Mid brown grey clay silt		
3901	Layer				Natural. Mid red brown sand and gravel		

<b>Trench 40</b>							
General description						Orientation	N-S
Trench contains one pit and ditch. Consists of ploughsoil overlying natural geology of silty-clay, sand and gravel.						Length (m)	30
						Width (m)	2
						Avg. depth (m)	0.4
Ctxt No.	Type	Fill Of	Width (m)	Depth (m)	Description	Finds	Date
4000	Layer			0.39	Ploughsoil. Mid-grey brown, silty-clay		
4001	Layer				Natural. Mid orange brown, silty-sand with fine gravel patches		
4002	Cut		0.69	0.09	Pit. Circular		
4003	Fill	4002	0.69	0.09	Primary Fill. Dark greyish brown, silty sand		
4004	Cut		0.55	0.19	Ditch. Linear		
4005	Fill	4004	0.55	0.19	Primary Fill. Mid grey brown, silty clay and frequent stone inclusions		

<b>Trench 41</b>							
General description						Orientation	N-S
Trench devoid of archaeology. Consists of ploughsoil overlying natural geology						Length (m)	30
						Width (m)	2.1
						Avg. depth (m)	0.27
Ctxt No.	Type	Fill Of	Width (m)	Depth (m)	Description	Finds	Date
4100	Layer			0.27	Ploughsoil. Dark greyish-brown, silty sand		
4101	Layer				Natural. Mid orange brown, sandy gravel		

<b>Trench 42</b>							
General description						Orientation	NE-SW
Trench devoid of archaeology. Consists of topsoil and subsoil overlying natural geology.						Length (m)	30
						Width (m)	2.1
						Avg. depth (m)	0.28
Ctxt No.	Type	Fill Of	Width (m)	Depth (m)	Description	Finds	Date
4200	Layer			0.28	Ploughsoil. Dark greyish-brown, silty sand		
4201	Layer				Natural. Mid orange-brown, silty sand with gravel patches		

<b>Trench 43</b>							
General description						Orientation	NE-SW
Trench contained one ditch. Consists of ploughsoil overlying natural geology						Length (m)	30
						Width (m)	2
						Avg. depth (m)	0.27
Ctxt No.	Type	Fill Of	Width (m)	Depth (m)	Description	Finds	Date
4300	Layer			0.3	Ploughsoil. Dark grey brown, silty clay		
4301	Layer				Natural. Mid orangey brown, silty sand and gravel		
4302	Cut		1.2	0.36	Ditch. Boundary ditch		
4303	Fill	4302	1.2	0.14	Primary Fill. Dark greyish-brown, silty sand		
4304	Fill	4302	1.04	0.2	Secondary Fill. Mid yellowish-brown, silty sand		

<b>Trench 44</b>							
General description						Orientation	E-W
Trench devoid of archaeology. Consists of ploughsoil overlying natural geology						Length (m)	30
						Width (m)	2
						Avg. depth (m)	0.33
Ctxt No.	Type	Fill Of	Width (m)	Depth (m)	Description	Finds	Date
4400	Layer			0.33	Ploughsoil. Dark grey brown, silty clay		
4401	Layer				Natural. Mid orangey/red brown, silty sand and gravel. Plough scars contamination		
4402	Cut		0.71	0.22	Natural Feature. Irregular patch. Part of the natural geology.		
4403	Layer		0.71	0.22	Natural. Silty-clay patch, part of the natural geology.		

<b>Trench 45</b>							
General description						Orientation	N-S
Trench devoid of archaeology. Consists of topsoil and subsoil overlying natural geology.						Length (m)	30
						Width (m)	2
						Avg. depth (m)	0.32
Ctxt No.	Type	Fill Of	Width (m)	Depth (m)	Description	Finds	Date
4500	Layer			0.29	Ploughsoil. Mid brown grey clay silt		
4501	Layer			0.1	Subsoil. Mid grey brown silt clay		
4502	Layer				Natural. Mid red brown sand and gravel		

<b>Trench 46</b>							
General description						Orientation	NE-SW
Trench devoid of archaeology and consisted of topsoil and subsoil overlying natural geology						Length (m)	30
						Width (m)	2.1
						Avg. depth (m)	0.35
Ctxt No.	Type	Fill Of	Width (m)	Depth (m)	Description	Finds	Date
4600	Layer			0.32	Ploughsoil. Dark grey brown, silty clay		
4601	Layer				Natural. Mid orange brown, silty sand with gravel patches		

<b>Trench 47</b>							
General description						Orientation	NW-SE
Trench revealed four natural features. Two of the features were left unexcavated. Consists of ploughsoil overlying natural geology						Length (m)	30
						Width (m)	2.1
						Avg. depth (m)	0.3
Ctxt No.	Type	Fill Of	Width (m)	Depth (m)	Description	Finds	Date
4700	Layer			0.3	Ploughsoil. Dark grey brown, silty clay		
4701	Layer				Natural. Mid orange brown, silty sand with gravel patches		
4702	Cut		0.91	0.32	Natural Feature. Linear band of natural silting, NE-SW alignment		
4703	Fill	4702	0.91	0.32	Secondary Fill. Mid orange-brown, Friable, silty sand with frequent patches of fine gravel		
4704	Cut		0.84	0.23	Natural Feature. Sub-oval, possible tree throw		
4705	Fill	4704	0.84	0.32	Secondary Fill. Mid reddish-brown, sandy-silt, friable, with frequent fine gravel		

4706	Unexcavated feature		0.84		Natural Feature. Layer. Mid orange brown, sandy silt with fine gravel		
4707	Unexcavated feature		1.53		Natural Feature. Layer. Mid orange-brown, sandy-silt with frequent fine gravel		

<b>Trench 48</b>							
General description						Orientation	NE-SE
Trench devoid of archaeology. Consists of ploughsoil and subsoil overlying natural geology						Length (m)	30
						Width (m)	2
						Avg. depth (m)	0.38
Ctxt No.	Type	Fill Of	Width (m)	Depth (m)	Description	Finds	Date
4800	Layer			0.28	Ploughsoil. Dark grey brown, silty clay		
4801	Layer			0.1	Subsoil. Thin subsoil layer more present on NE end and disappearing towards SW		
4802	Layer				Natural. Mid orangey brown, silty and gravel		

<b>Trench 49</b>							
General description						Orientation	NE-SW
Trench devoid of archaeology. Consists of topsoil overlying natural geology.						Length (m)	20
						Width (m)	2
						Avg. depth (m)	0.3
Ctxt No.	Type	Fill Of	Width (m)	Depth (m)	Description	Finds	Date
4900	Layer			0.3	Ploughsoil. Dark grey brown, silty clay		
4901	Layer				Natural. Mid orangey brown, silty sand with gravel patches		

## Appendix B Finds Reports

### B.1 Pottery

By Alex Davies

- B.1.1 Three contexts produced prehistoric pottery: 4003, 4005, 2804. This totalled 41 sherds weighing 203g. All of the pottery could belong to the same period. The lack of diagnostic material precluded certain dating, although the material is probably late Bronze Age, but could belong to the early or middle Iron Age. The assemblage is presented in Table 1.
- B.1.2 The majority of the assemblage was tempered with flint in varying grades. One vessel had fine sand inclusions. Four vessels were burnished.
- B.1.3 Flint is the dominant fabric type in the region in the late Bronze Age, being replaced with sand through the Iron Age (e.g. Mucking: Barrett and Bond 1988, 25-7; Evans *et al.* 2016, 158-160, 235-40, 379-80). Locally, however, flint remained a strong presence into the middle Iron Age, suggesting the possibility that this pottery is as late as the middle Iron Age (eg Mucking: Evans *et al.* 2016, 379; Orsett Cock: Brown 1998, 89).
- B.1.4 The only vessel that had a recognisable form was a dish with a pinched cordon from 4003. While dishes are a consistent but uncommment feature of late Bronze Age and early/middle Iron Age assemblages, the addition of a cordon is highly unusual. More precise dating of the vessel on the basis of the form is therefore problematic.

Vessel	Context	Sherds	Weight	Fabric	Comment
1	4003	21	100g	Flint: medium-fine	Very unusual dish with pinched cordon. Rim dia: 110mm; Base dia: 80mm; Height: 49mm
2	4003	1	11g	Flint: medium-fine	Burnished
3	4003	2	18g	Flint: medium-fine	Burnished. Carbonised residue, possibly enough for C14 dating
4	4003	1	17g	Flint: fine	Burnished
5	4003	5	17g	Sand: fine	Burnished
6	4005	1	4g	Flint: medium	
7	4005	7	21g	Flint: medium-fine	Carbonised residue, possibly enough for C14
8	2804	3	15g	Flint: medium	Highly abraded, not surfaces surviving

Table B1: Quantification of prehistoric pottery

## B.2 Flint

By Michael Donnelly

- B.2.1 A very small assemblage of four struck flints and a single fragment of burnt unworked flint weighing 3g was recovered from this evaluation (Table 2). The struck flint was widely spread across site with only a single example from any context or trench. The flintwork was largely non-period specific but there was one blade tool that is very likely to be Mesolithic or early Neolithic in date.
- B.2.2 Three of the flints were topsoil finds while the fourth came from ditch 2102, fill 2103. One of the topsoil finds was of note. This piece was recovered from context 1400 and represented a complex edge retouch preparation blade with retouch around all its edges. The left edge had scraper-like retouch while the distal end and right side had areas of denticulated retouch alongside shallower and more regular knife-like working. This complex blade tool is very probably early Neolithic in date but could also be Mesolithic.
- B.2.3 The single fragment of burnt unworked material came from pit 4002, fill 4003 but could easily have been accidentally burnt.
- B.2.4 This small assemblage indicates a limited amount of activity during prehistory including early prehistoric activity. The scale of this activity is very low and it is unlikely that any intensive levels of flint-related activity would be encountered during any further stage of work here.

### Methodology

- B.2.5 The artefacts were catalogued according to OA South's standard system of broad artefact/debitage type (Anderson-Whymark 2013; Bradley 1999), general condition noted and dating was attempted where possible. The assemblage was catalogued directly onto a spreadsheet.

Context	Type	Sub-type	Notes	Date
1400	Other retouch	Preparation blade	Complex tool with scraper-like retouch left edge and knife -denticulate retouch right edge and distal, formed on a preparatory blade, likely to be early	EPH
2103	Flake	Inner		
2300	Flake	Inner	Thick piece with edge battering that looks to be unintentional	
3600	Flake	Inner	Lesser levels of edge damage on large possible Levallois flake	
4003	Burnt unworked	fragment	3g	

Table B2: Quantification of worked and burnt flint



## Appendix C Environmental Reports

### C.1 Environmental Samples

By Richard Palmer

#### Introduction

C.1.1 A single 5L bulk sample was taken, primarily for the retrieval and assessment of charred plant remains (CPR) and the recovery of bones and artefacts.

#### Method

C.1.2 The sample was processed in its entirety at Oxford Archaeology using a modified Siraf-type water flotation machine. The flot was collected in a 250µm mesh and heavy residue in a 500µm mesh and dried. The residue fractions were sorted by eye and with the aid of a magnet while the flot material was sorted using a low power (x10) binocular microscope to extract cereal grains and chaff, smaller seeds and other quantifiable remains.

#### Results and discussion

C.1.3 A summary of the flot material is presented in Table 3.

C.1.4 Sample 1 is from fill 3802 of pit 3803. A 16ml flot was produced and all recovered charred material was <4mm in size and consisted of charcoal and some clinker like material. No seeds were identified in the flot. Some of the recovered charcoal had one or more planes <2mm in size which would hinder any further identification work. Recovered material is of limited interpretive value and is unlikely to require further analysis. Some flint was recovered from the heavy residue.

Sample no.	Context no.	Area/Trench	Feature/Deposit	Date	Sample vol. (L)	Flot vol. (ml)	Charcoal >2mm	Grain	Chaff	Weeds	Molluscs	Other	Notes
1	3802	Tr. 38	3803		5	16	+++				+		10YR 4/2 sandy silt.

Key: +=present (up to 5 items), ++=frequent (5-25), +++=common (25-100), ++++=abundant (100+).

Table C3: Assessment of Charred Plant Remains flot

## Appendix D      References

---

- Anderson-Whymark, H. (2013). *The flint*, in Allen, T, Barclay, A, Cromarty, A, M, Anderson-Whymark, H, Parker, A, Robinson, M, and Jones, G, *Opening the wood, making the Land; The Archaeology of a Middle Thames Landscape, Mesolithic, Neolithic and Bronze Age*. Oxford Archaeological Unit, TVLM 38.
- Barrett, J C, and Bond, D. (1988). Pottery in Bond, Excavation at the North Ring, Mucking. *East Anglian Archaeology* 43, 25-37, 25-37.
- Buckley, D, Hedges, J, and Priddy, D. (1987) Excavation of a Cropmark Enclosure Complex at Woodham Walter, Essex, 1976 and An Assessment of Excavated Enclosures in Essex, *East Anglian Archaeology* 33
- Bradley, P. (1999). *The worked flint*. In A. Barclay and C. Halpin. Eds. *Excavations at Barrow Hills, Radley, Oxfordshire*. Oxford: Oxford Archaeological Unit. Thames Valley Landscapes Monograph 11: 211-227.
- BGS. (2019). *Geology of Britain Viewer*. Retrieved from <http://mapapps.bgs.ac.uk/geologyofbritain/home.html>
- Brown, N. (1998). Earlier Iron Age pottery, in G A Carter, Excavations at the Orsett 'Cock' Enclosure, Essex, 1976, . *East Anglian Archaeology* 86 , 88-9.
- Chartered Institute for Archaeologists (CIfAa). (2014). *Standard and Guidance for Archaeological Evaluation*. Retrieved from <http://archaeologists.net/sites/default/files/node-files/IfASG-Evaluation.pdf>
- Chartered Institute for Archaeologists (CIfAb). (2014). *Standard and Guidance for the Creation, Compilation, Transfer and Deposition of Archaeological Archives*.
- Evans, C, Appleby, G, and Lucy, S. (2016). Lines in the Land: Mucking Excavations by Margaret and Tom Jones, 1965-1978. Prehistory: context and summary. *Cambridge Archaeological Unit Archives Series: Historiography and Fieldwork 2/Mucking* 6.
- Hedges, J. D. and Buckley, D. G. 1978. Excavations at a Neolithic causewayed enclosure, Orsett, Essex, 1975. *Proceedings of the Prehistoric Society* 44, 219–308
- Highways England. (2018). *Lower Thames Crossing: A Scheme Wide Specification for Archaeological Trial Trenching: unpublished document HE540039-CJV-GEN-GEN-SPE-HER-00001draft, Revision 1.05*.
- Historic England. (2015). *Management of Research Projects in the Historic Environment: The MoRPHE Project Managers' Guide*. Swindon: Centre for Archaeology Guidelines.

- Medlycott, M ed. (2011). *Research and Archaeology Revisited: A Revised Framework for the East of England*. East Anglian Archaeology Occasional Paper 24: Association of Local Government Archaeological Officers.
- Oxford Archaeology. (2019a). *Lower Thames Crossing Scheme-wide Written Scheme of Investigation for Trial Trenching south of the River Thames*.
- Oxford Archaeology. (2019b). *Lower Thames Crossing Scheme-wide Written Scheme of Investigation for Trial Trenching north of the River Thames*.
- Oxford Archaeology. (2019c). *Lower Thames Crossing Detailed Written Scheme of Investgtion for Trial Trenching of Land Parcel 1*. Oxford Archaeology.
- Place Services. (2019). *Lower Thames Crossing Aerial Investigation and Mapping Report, Essex County Council*.
- Wilkinson, T. J. (1988). *Archaeology and Environment in South Essex: Rescue Archaeology on the route of the A13 Grays By-pass, 1979/80*. East Anglian Archaeology 42.

# Appendix E      Abbreviations and Glossary

---

**ADS** Archaeology Data Service. Digital archaeological archive

**CDM** Construction Design Manual. Health and safety guidance for the construction industry

**CPD** Continuing Professional Development

**CIfA** Chartered Institute for Archaeologists

**DBA** Desk Based Assessment. Detailed assessment of archaeology and other aspects of the historic environment

**DCO** Development Consent Order

**EIA** Environmental Impact Assessment. Detailed study of environmental impacts as directed under the The Town and Country Planning (Environmental Impact Assessment) Regulations 2017 following on from EU Directive EIA Directive (85/337/EEC)

**ES** Environmental Statement. The principal environmental report detailing environmental impacts within an EIA

**GPS** Global Positioning System

**HER** Historic Environment Record

**LTC** Lower Thames Crossing

**MCIfA** Member of the Chartered Institute for Archaeologists

**MoRPHE** Management of Research Projects in the Historic Environment

**NMP** National Mapping Programme. A study of aerial photographs and digitisation of resulting data into GIS. Originally funded by Historic England

**OASIS** Online Access to the Index of archaeological investigations.  
The OASIS project brings together a number of strategic partners: the Archaeology Data Service, Historic England, Historic Environment Scotland, and the Royal Commission on the Ancient and Historical Monuments of Wales under the umbrella of the University of York

**OCN** Old County Number. Historic England's reference for material that is not readily-available online and may represent historic archaeological work that consists of paper archives or has yet to be formally reported on

**PINS** Planning Inspectorate

**RAMS** Risk Assessment Method Statement

**SMC** Scheduled monument consent

**TDR** Trusted Digital Repository

**UKIC** United Kingdom Institute for Conservation

**WSI** Written Project of Investigation. A detailed method statement for archaeological work

**WSL** – Western Southern Link  
The Western Southern Link (WSL) is an alternative for Short List Routes 2, 3 and 4 to the south of the River Thames.

## Appendix F Site Summary

---

<b>Site name:</b>	Lower Thames Crossing Land Parcel 1 Masons Corner, Heath Road, Orsett Heath, Essex
<b>Site code:</b>	LTC1MC 19
<b>Grid Reference</b>	TQ 63914 80335
<b>Type:</b>	Evaluation
<b>Date and duration:</b>	28th November - 6th December 2019
<b>Area of Site</b>	8.43ha
<b>Location of archive:</b>	The archive from Land Parcel 1 will form part of the overall trial trenching scheme archive. This will be deposited in a repository consistent with the standards required by the Museums and Galleries Commission following completion of the archaeological phase of this project. This may either be with the local receiving museum in Thurrock or, if no such repositories are available, with a repository for the whole project designated by LTC. LTC retain the overall responsibility for the successful deposition of the project archive.

Currently, the archive is held at Oxford Archaeology's head office, Janus House, Osney Mead, Oxford, Oxfordshire, OX2 0ES. Oxford Archaeology will store the archive for LTC for a maximum period of 2 years following the completion of the project. If the storage of the archive at OA's office extends past this period, an extension to the storage period and final deposition timetable will be reviewed by OA and LTC and agreed with the major stakeholders.

**Summary of Results:** Oxford Cotswold Archaeology was commissioned by Balfour Beatty to undertake a trial trench evaluation of Land Parcel 1 of the Lower Thames Crossing Pre-Enabling Works. Land Parcel 1, also known as Masons Corner, is located c 200m north of the hamlet of Orsett Heath within the county of Essex and Thurrock unitary authority (NGR 563914 180335). The evaluation comprised 49 trenches and was completed between the 28th November and the 6th December 2019.

Two trenches in the north-western part of the site contained features that were dated to the late Bronze Age, including a NE-SW ditch, a pit and a posthole. This indicates late Bronze Age activity in this area, although a more detailed interpretation of this is not possible from the scant remains encountered.

A number of undated archaeological features were identified within the northern, eastern and south-western part of the site, including two postholes, a NW-SE aligned ditch, a NE-SW aligned ditch, a NW-SE aligned gully and four pits.

Two NNW-SSE aligned ditches in the western part of the site match a linear cropmark and a field boundary on the Orsett 1840 tithe map and are very likely post-medieval in date. Another NE-

SW ditch was also thought to be post-medieval as it also matched a cropmark that was perpendicular to the NNW-SSE aligned linear.

The site contained a large number of irregular-shaped features, 1-3m in diameter, which were identified as cropmarks and were targeted in numerous trenches. Where investigated, these comprised variations in the gravel or sand and silt content of the geology and were clearly not of archaeological origin.

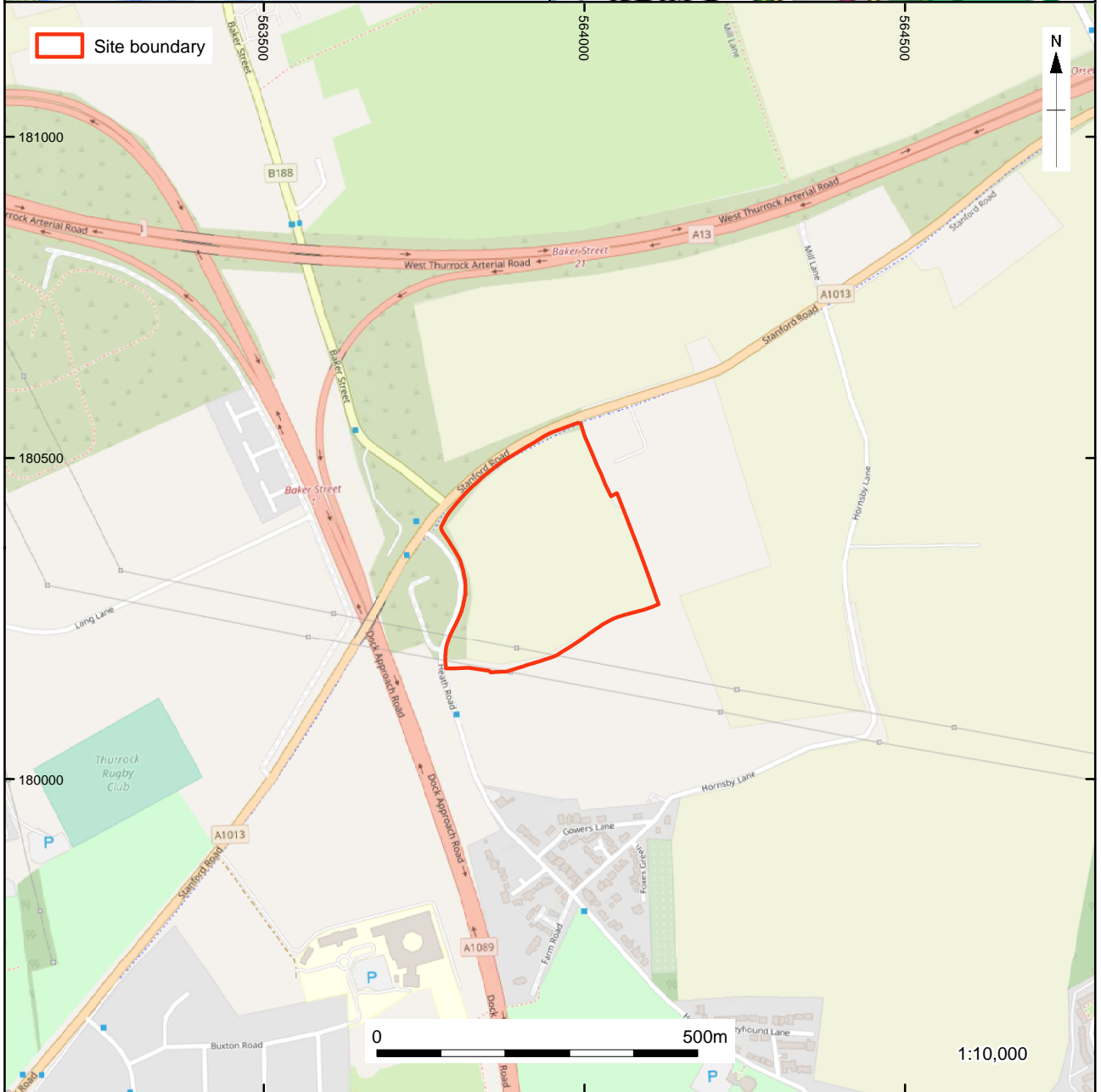
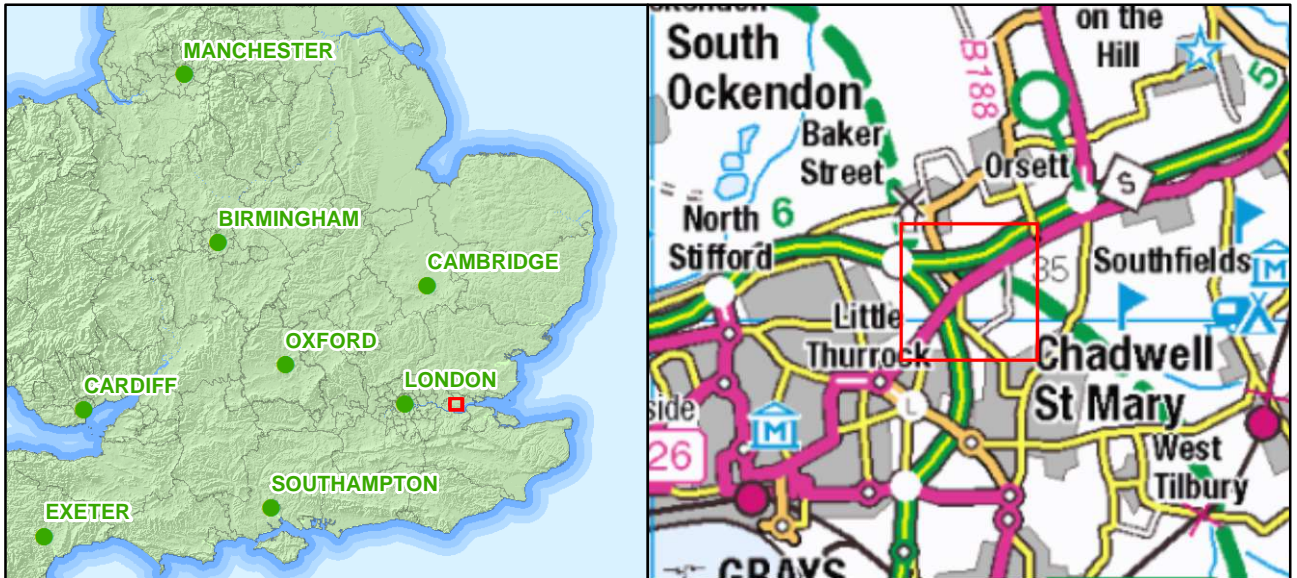

Contains Ordnance Survey data © Crown copyright and database right 2020

Figure 1: Map showing the location of Land Parcel 1

X:\MIL\TOEV\_Lower\_Thames\_Crossing\010\Geomatics\03 GIS Projects - LTC1MC19\Figures\LTC1MCEV\_Fig1.mxd\geomatics\09/01/2020

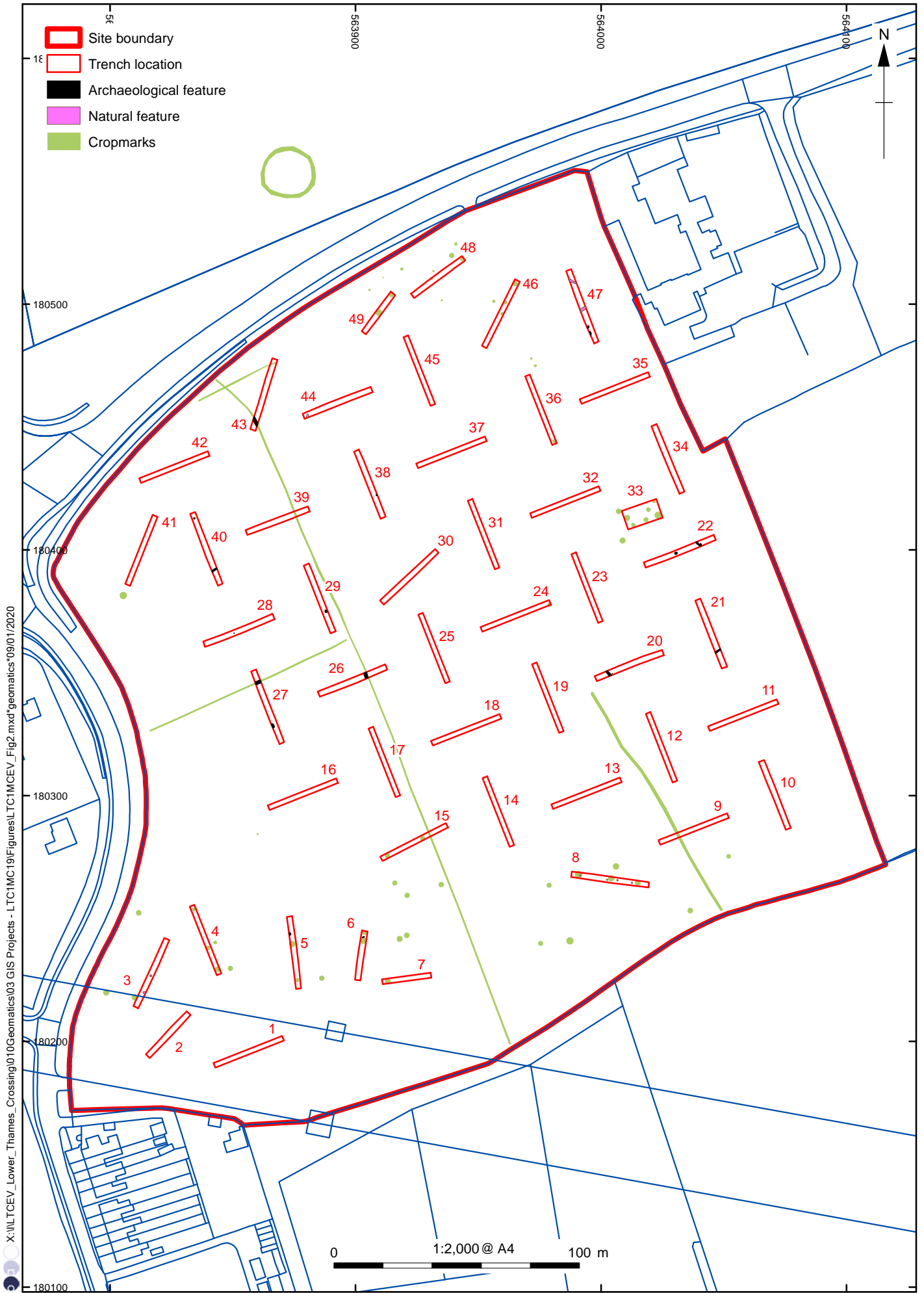

Figure 2: Plan of trench layouts, cropmark features and archaeological features



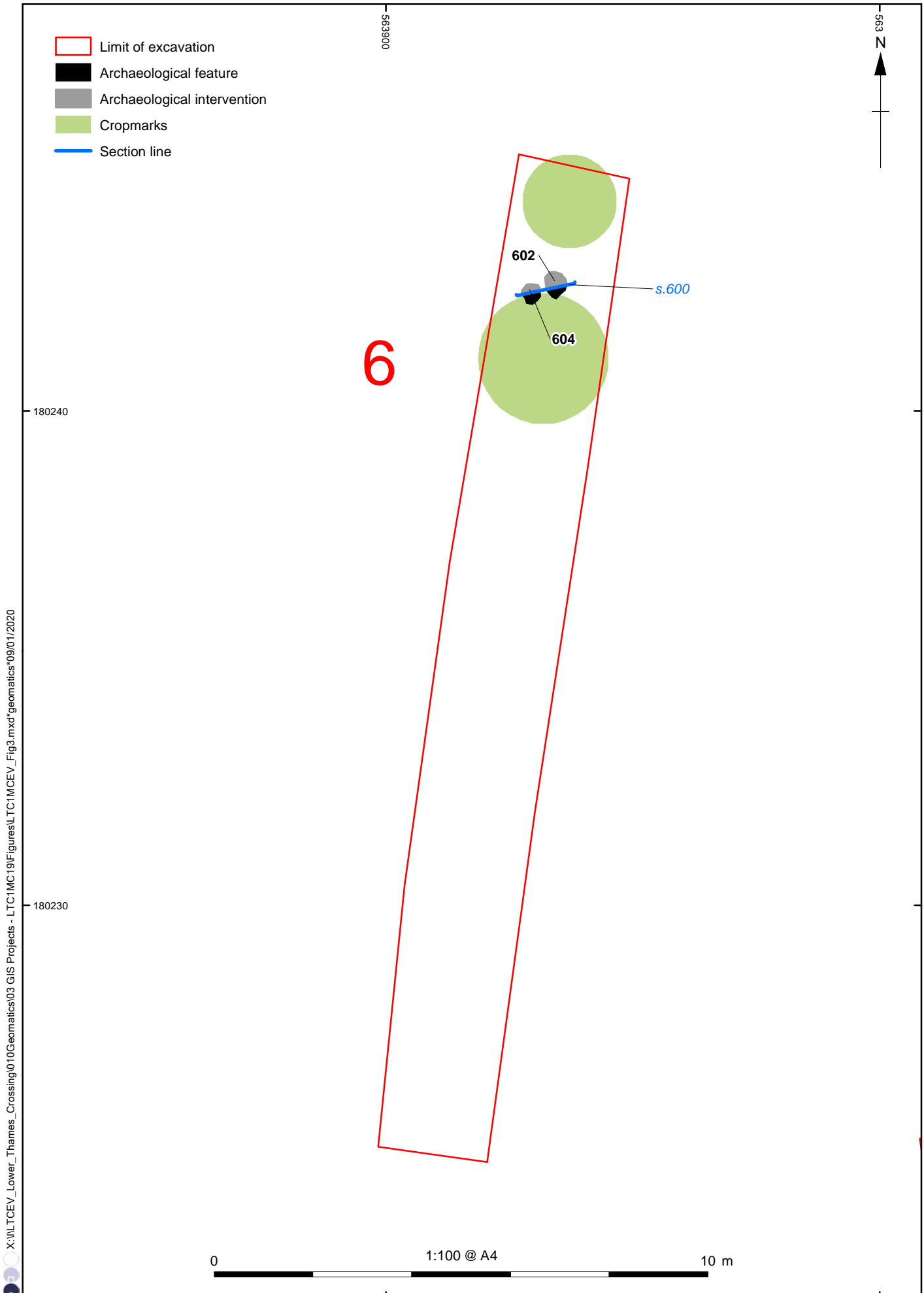

Figure 3: Plan of Trench 6

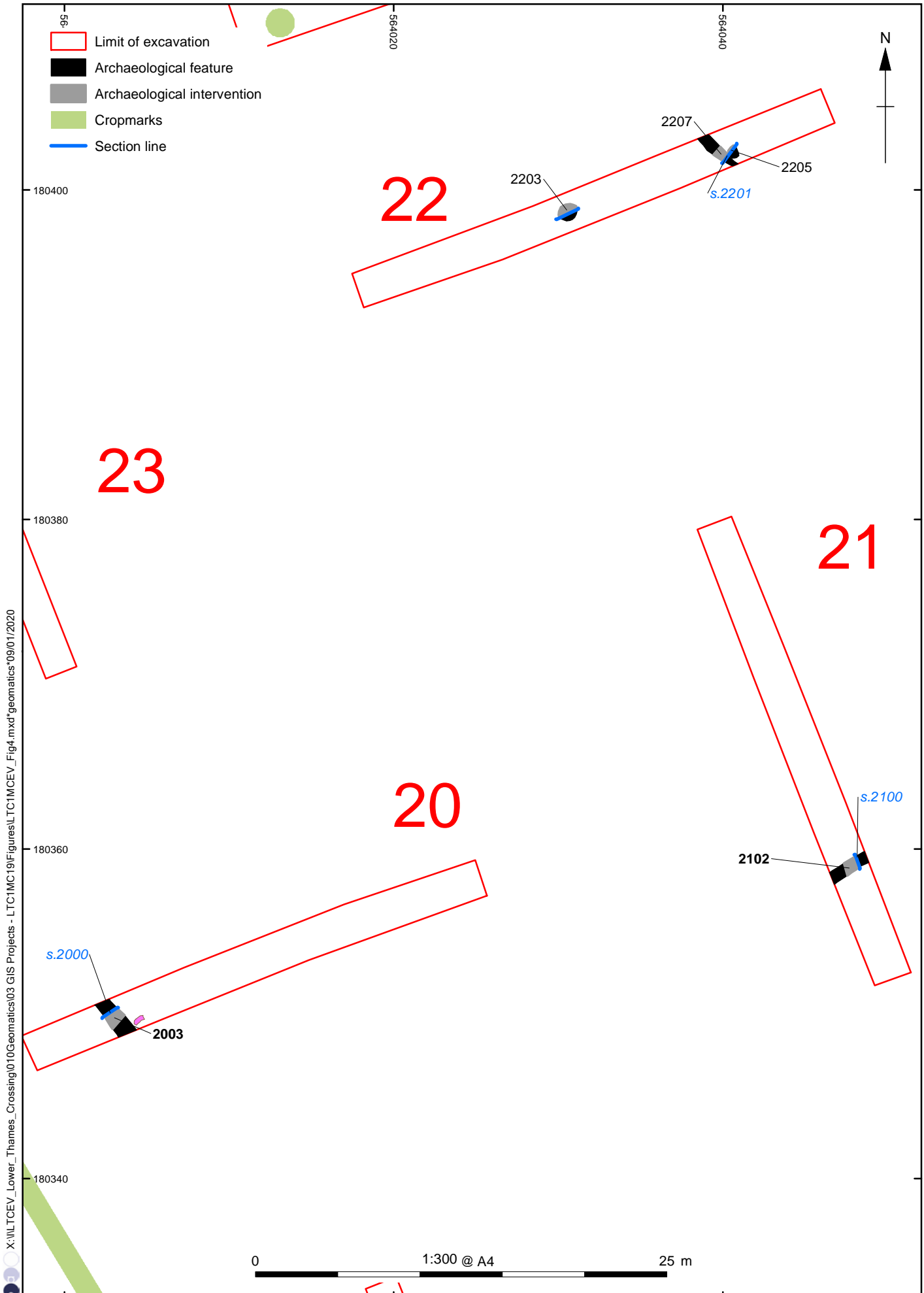

Figure 4: Plan of Trench 20, 21 and 22

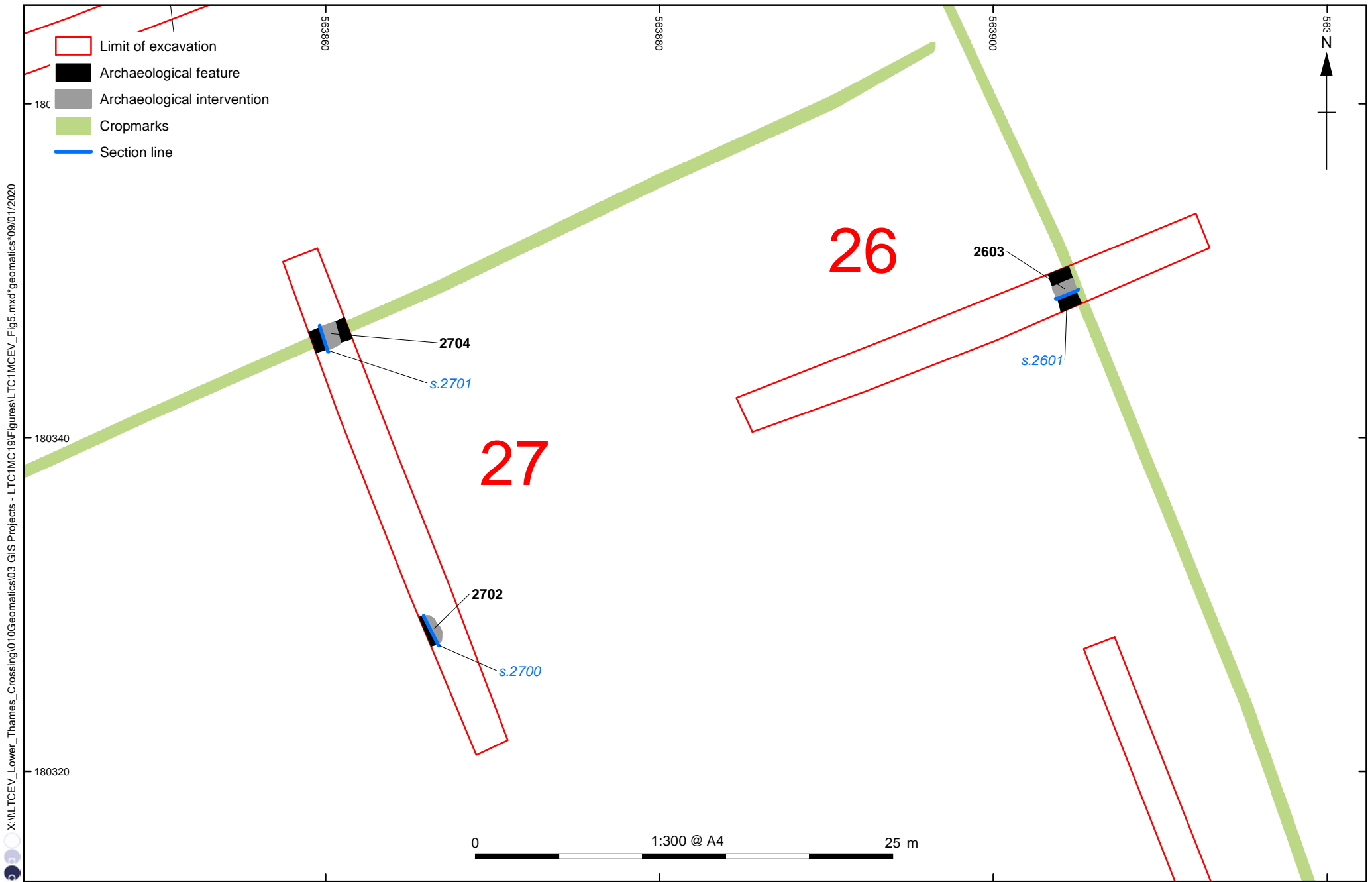

Figure 5: Plan of Trench 26 and 27

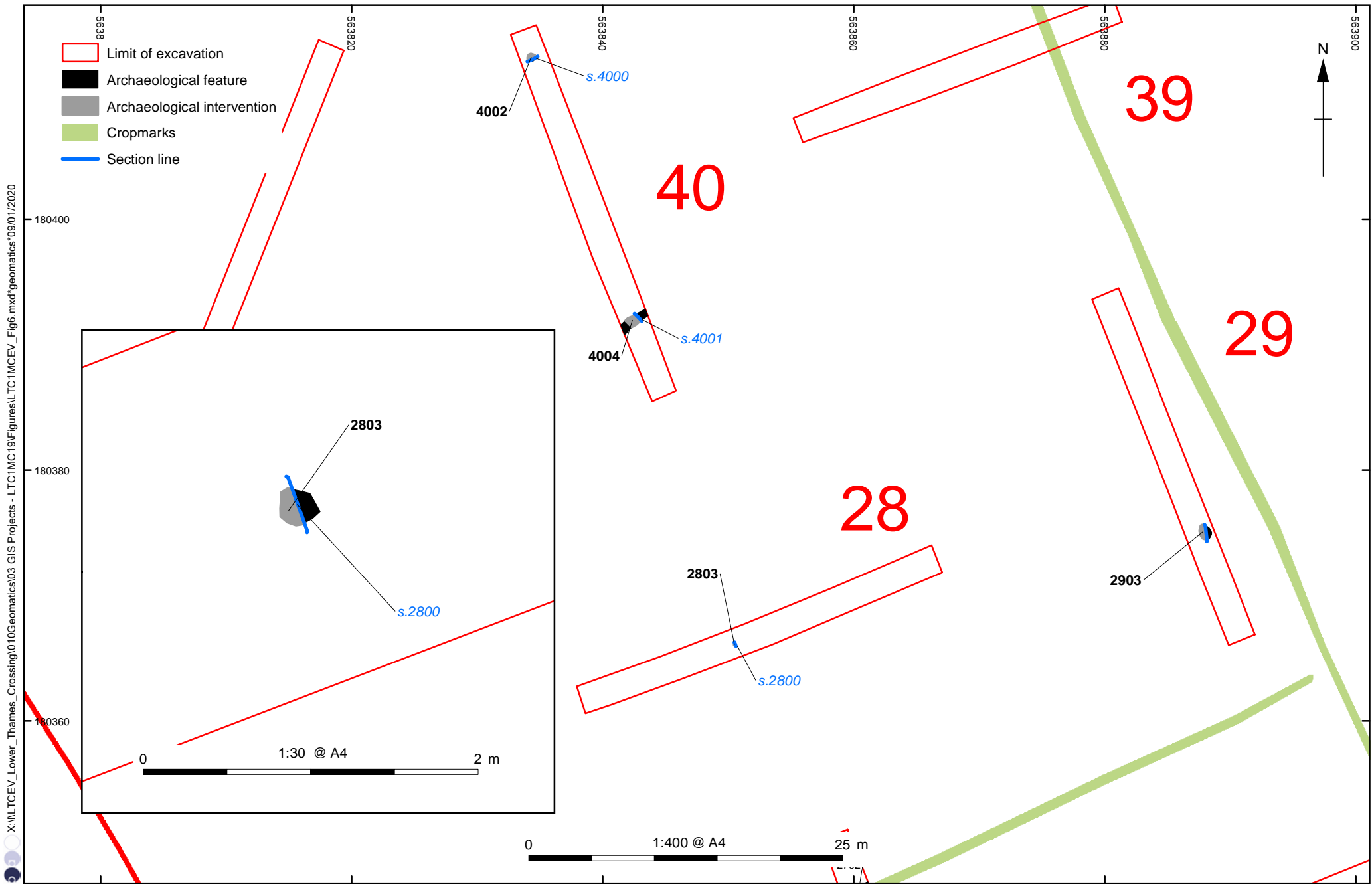

Figure 6: Plan of Trench 28, 29, and 40

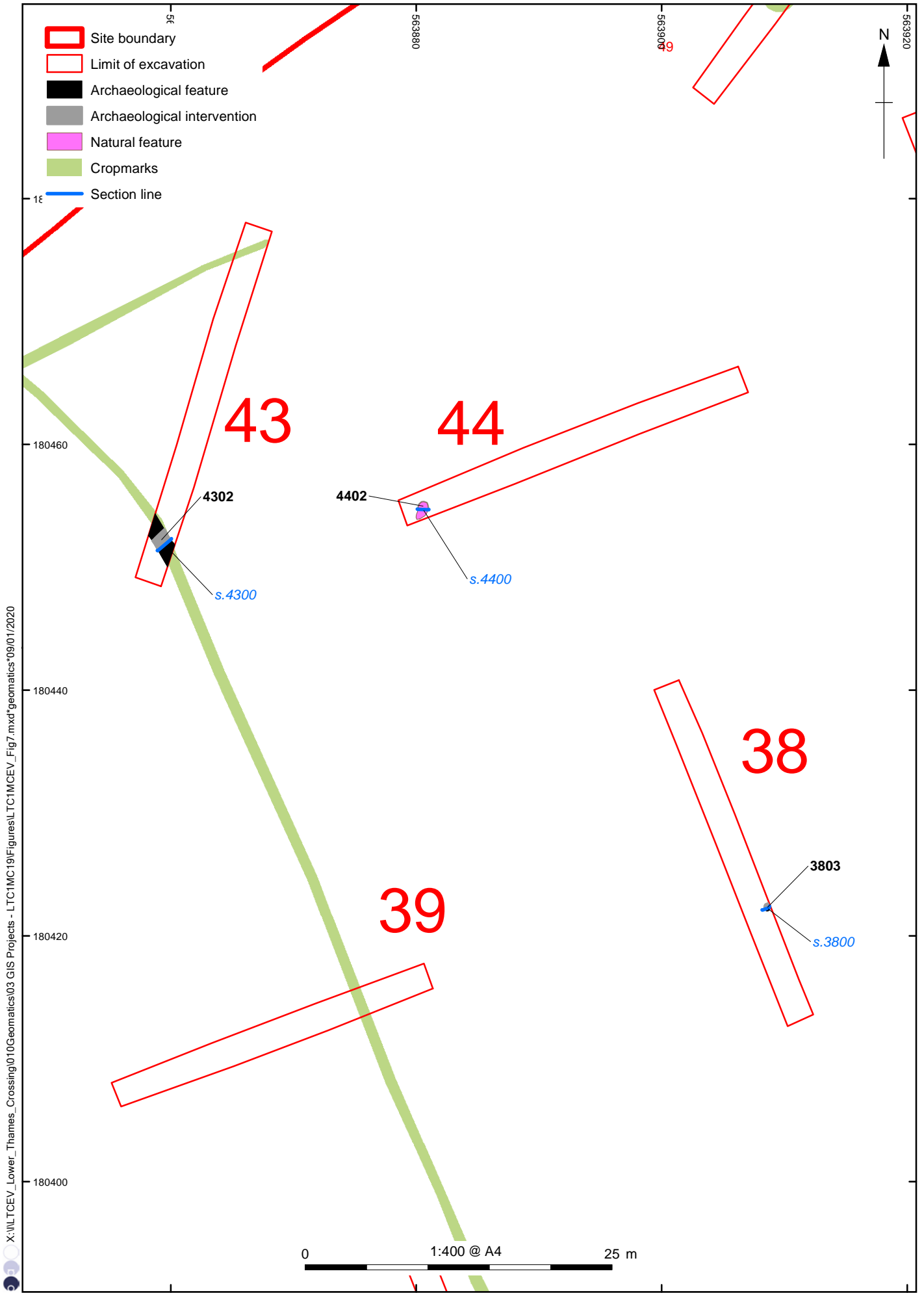

Figure 7: Plan of Trench 38, 43 and 44

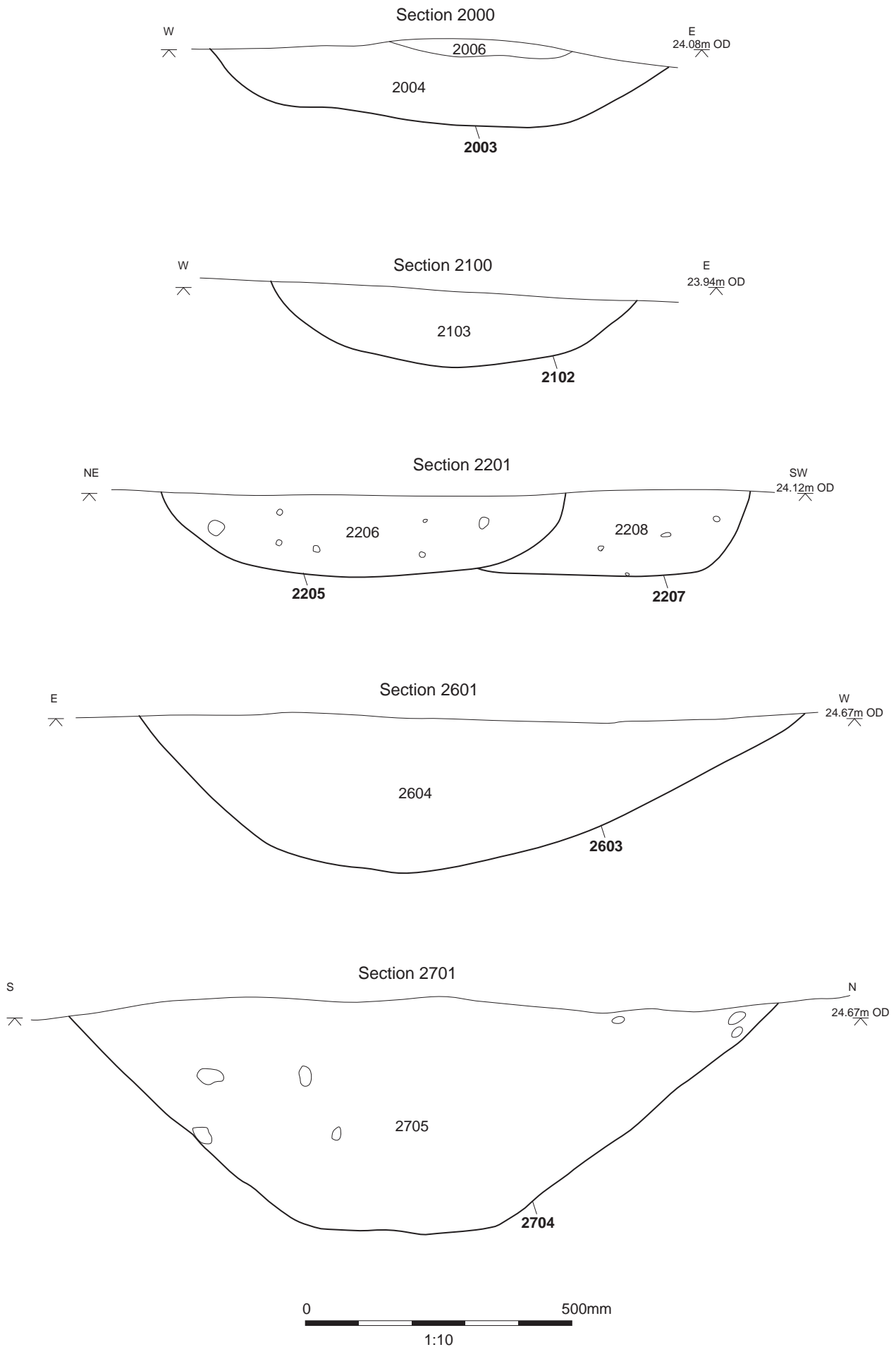

Figure 8: Sections (Trenches 20, 21, 22, 26 and 27)

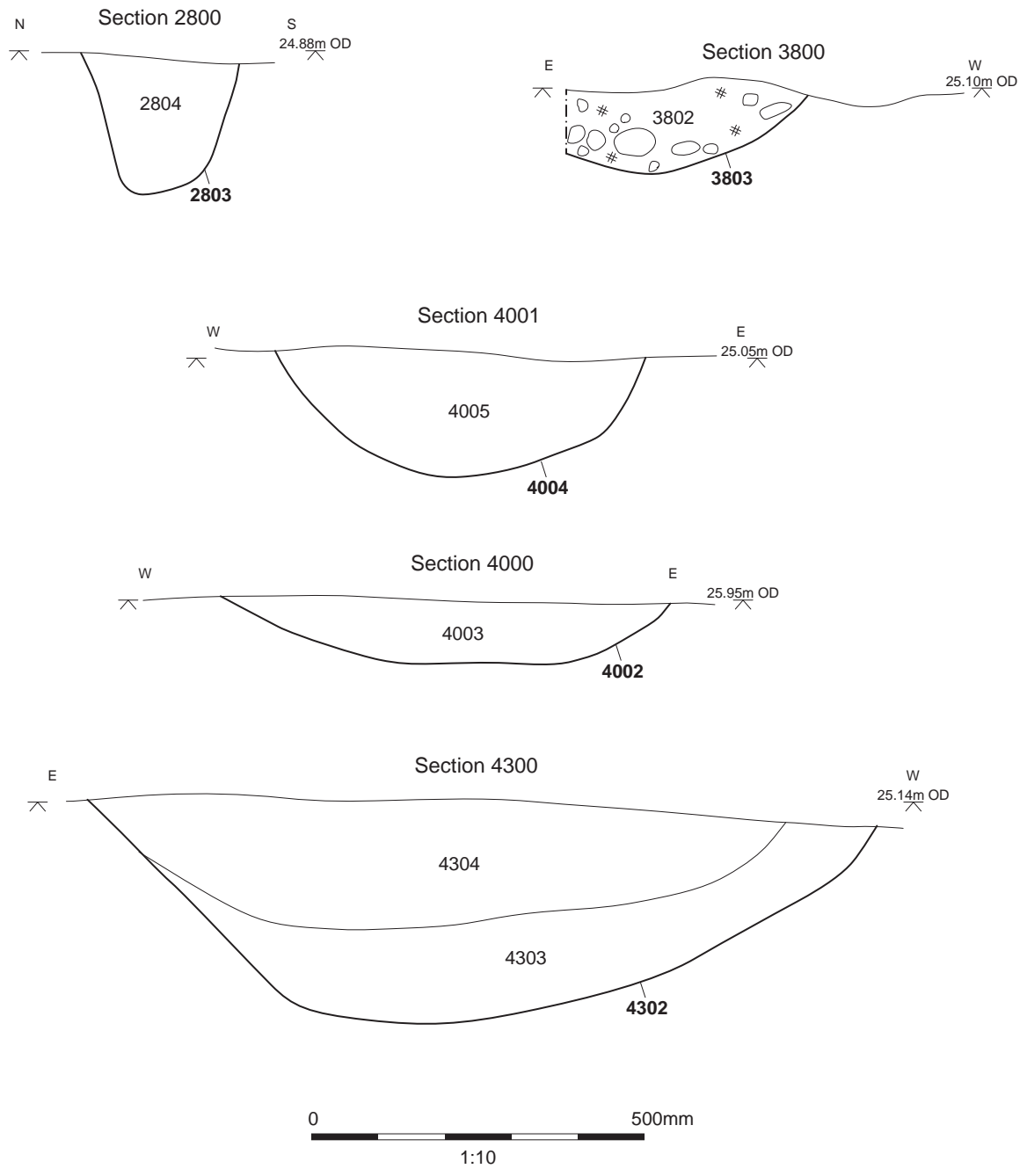

Figure 9: Sections (Trenches 28, 38, 40 and 43)



Plate 1: Ditch 2102 facing north-east



Plate 2: Ditch 2603 facing south





Plate 3: Ditch 2704 facing west



Plate 4: Posthole 2803 facing east



Plate 5: Pit 3803 facing south



Plate 6: Ditch 4004 facing north-east

**COVER SHEET**

<b>Title:</b>	<b>OA Archaeological Evaluation Report for Trial Trenching of Land Parcel 2</b>
<b>Project Name:</b>	<b>Lower Thames Crossing Enabling Works</b>
<b>Ref No:</b>	<b>HE540039-BAL-GEN-GEN-REP-HER-00021</b>
<b>Revision No:</b>	<b>P01</b>
<b>Review Date:</b>	<b>11/01/2021</b>
<b>Status:</b>	<b>S2 – For Information</b>
<b>No. of Pages</b>	<b>66</b>

<b>Rev</b>	<b>Date of Issue</b>	<b>Revision Status</b>	<b>Originator</b>	<b>Checker</b>	<b>Approver</b>
P01	11/01/2021	S2 For Information	Bikash Rana	Jack Fletcher	Emily Erswell



# Lower Thames Crossing

Archaeological Evaluation Report for Trial Trenching of  
Land Parcel 2, Land North of Orsett Heath, Essex

Document Number: HE540039-BAL-GEN-GEN-REP-HER-00021

**January 2021**



Revision	Production Date	Prepared by	Checked by	Approved for release by	Sections revised
1.0	November 2020	<i>Steve Teague Post-excavation Project Officer, Oxford Archaeology</i>	<i>Tim Allen Senior Project Manager, Oxford Archaeology</i>	<i>Internal review only</i>	
1.1	December 2020	<i>revised by: Tim Allen Senior Project Manager, Oxford Archaeology</i>	<i>Steve Lawrence Senior Project Manager, Oxford Archaeology</i>		

This Evaluation Report has been prepared for Highways England in accordance with the terms and conditions of appointment stated in the Lower Thames Crossing (LTC) Technical Partner Contract. LTC cannot accept any responsibility for any use of or reliance on the contents of this document by any third party.

# Contents

---

Section	Page
<b>Summary</b> .....	<b>5</b>
<b>Acknowledgements</b> .....	<b>6</b>
<b>1 Introduction</b> .....	<b>7</b>
1.1 Project details and scope of work .....	7
1.2 Location, topography and geology .....	8
1.3 Previous investigations .....	8
1.4 Archaeological and historical background.....	8
<b>2 Project Aims</b> .....	<b>11</b>
2.1 General aims .....	11
2.2 Specific objectives .....	12
<b>3 Methodology</b> .....	<b>14</b>
3.1 Constraints.....	14
3.2 Methodology for the evaluation .....	14
<b>4 Results</b> .....	<b>16</b>
4.1 Introduction and presentation of results .....	16
4.2 General soils and ground conditions.....	16
4.3 General distribution of archaeological deposits .....	16
4.4 Trenches 8-11, Northern cluster (Fig. 3).....	17
4.5 Trenches 4 and 6 (Figs 4 & 5) .....	17
4.6 Trench 14 (Figs 4 & 5).....	17
4.7 Trenches 24 – 27, 31, 32, 36 and 43 (Figs 4 – 7).....	18
4.8 Trenches 33, 35 and 37 (Figs 4, 6 and 7).....	20
4.9 Finds summary .....	21
4.10 Environmental summary .....	21
<b>5 Discussion</b> .....	<b>22</b>
5.1 Reliability of field investigation .....	22
5.2 Interpretation.....	22
5.3 Evaluation objectives and results.....	23
<b>Appendix A Trench Tables</b> .....	<b>25</b>
<b>Appendix B Finds Reports</b> .....	<b>44</b>
<b>Appendix C Environmental Reports</b> .....	<b>49</b>
<b>Appendix D References</b> .....	<b>51</b>
<b>Appendix E Abbreviations and Glossary</b> .....	<b>53</b>
<b>Appendix F Site Summary</b> .....	<b>54</b>

## Figures

Figure 1: Site location

Figure 2: Plan of trench layouts and archaeological features

Figure 3: North-east of Land Parcel 2: Trenches 8-12 and 20

Figure 4: West side of Land Parcel 2: Trenches 1-4, 6, 13-17, 21-25 and 30-33

Figure 5: Section 600: SSW facing section showing natural feature 605,  
Section 1400: ENE facing section showing pit 1403,  
Section 2500: NE facing section through ditch 2503

Figure 6: East side of Land Parcel 2: Trenches 26-28, 34-37 and 41-43

Figure 7: Section 2602: SE facing section through intercutting pits 2608 and 2610,  
Section 2700: NNW facing section through pit 2703 and posthole 2705,  
Section 3700: SW facing section through ditch 3703,  
Section 3701: SW facing section through ditch 3706,  
Section 3703: NE facing section through posthole 3715 and ditch 3712

## Plates

Plate 1: South facing section 600 of natural feature 605

Plate 2: East facing section 1400 of pit 1403

Plate 3: North-east facing section 2500 of ditch 2503

Plate 4: South-east facing section 2602, pits 2608 and 2610

Plate 5: North facing section 2700, pit 2703 and posthole 2705

Plate 6: South-west facing section 3700 of ditch 3703

Plate 7: South-west facing section 3701 of ditch 3706

Plate 8: North-east facing section 3703 of ditch 3712 and posthole 3715

## Tables

Table 1: Prehistoric pottery

Table 2: Quantification of the worked and burnt flint

Table 3: Assessment of environmental samples

## Summary

---

Oxford Cotswold Archaeology was commissioned by Balfour Beatty to undertake a trial trench evaluation of Land Parcel 2, covered by WSI B of the Lower Thames Crossing Pre-Enabling Works. This land parcel is located c 30m north of the hamlet of Orsett Heath within the county of Essex and Thurrock unitary authority (NGR 564047 180101). A total of 41 trenches were excavated and recorded between 7th and 16th October 2020.

One early Neolithic pit was found in Trench 14 in the western part of the site, and one late Neolithic/early Bronze Age pit containing Beaker finds in the eastern half in Trench 27. These add to a pattern of dispersed early prehistoric activity on the gravel terrace identified from previous discoveries on the gravels in this area.

One pit containing later prehistoric (middle Bronze Age to early Iron Age) pottery was found in Trench 26, and two pits containing sherds only datable as prehistoric are also likely to be of later prehistoric date. Undated pits and ditches, including one curvilinear example, were scattered across the site, and many of these are also likely to be of prehistoric date, given the absence of later features or finds from the site.

No evidence of Roman or Anglo-Saxon activity was found, and only a single sherd of medieval pottery, although this was a rare continental import and thus of intrinsic interest.

Post-medieval finds were sparse. One NNW-SSE ditch in Trench 27 may well correspond to a boundary shown on the Tithe map of c 1840, although no continuation of this boundary was seen in Trench 41, which also crossed its line. It is likely that some of the undated ditches, particularly those on NNW-SSE or ENE-WSW alignments, may well be field boundaries of post-medieval date.



## Acknowledgements

---

Oxford Cotswold Archaeology would like to thank the client, Balfour Beatty, for commissioning this project and managing the site safety and attendances. Thanks are also extended to the Historic Environment Consultants (Richard Havis and Katie Lee-Smith) of Place Services at Essex County Council, who advise the Borough of Thurrock, for monitoring and providing advice throughout the project.

The project was managed for Oxford Cotswold Archaeology by Steve Lawrence. The fieldwork was directed by Mark Dodd and Jonathan Orellana, who were supported by George Gurney, Eilidh Barr, Rachel Alexander, Chris Griffiths, Stephen Forster, Kerree Kendall and Alice Golton. Site survey was undertaken by Caroline Souday and digitising was carried out by Gary Jones, Benjamin Brown and Aidan Farnan. Thanks are also extended to the teams of OA staff that cleaned and packaged the finds under the management of Leigh Allen and Geraldine Crann, processed the environmental remains under the management of Rebecca Nicholson, and prepared the archive under the management of Nicola Scott.

# 1 Introduction

---

## 1.1 Project details and scope of work

- 1.1.1 The Lower Thames Crossing (LTC) project is located between the A2 in Kent and the M25 in the London Borough of Havering. It will run underneath the River Thames through a tunnel and emerge on the north side of the river at East Tilbury. From the North Portal the road will run to the M25 at Junction 29 via the A13 and pass between North and South Ockendon. The development of the project is managed by LTC, a partnership between Highways England and a consultancy joint venture set up to oversee the scheme.
- 1.1.2 A programme of archaeological trial trenching commenced in the Essex part of the scheme in November 2019. A scheme-wide specification for trial trenching was written by LTC (Highways England 2018), and in July 2019, LTC commissioned Balfour Beatty to deliver the pre-Enabling Works. Balfour Beatty appointed Oxford Archaeology (OA) to prepare a project-wide written scheme of investigation (WSI) for the scheme, which (at the request of the key archaeological stakeholders) is divided into two parts, one for the Kent section, and another for Essex and Havering (Oxford Archaeology 2019a; 2019b).
- 1.1.3 Following completion of the project-wide WSIs, OA was instructed to prepare a series of site-specific or group-site specific WSIs for approval by the key archaeological stakeholders in advance of trial trenching to inform the Development Consent Order (DCO). A detailed WSI was created for Land Parcel 2 prior to the trial trenching (WSI B, Oxford Archaeology 2019c), which details the archaeological background and potential within the site. It also sets out the archaeological aims and objectives appropriate to the investigation of this land parcel by trenching and describes the methodology to be applied. The WSI was approved by Richard Havis, Principal Historic Environment Consultant for Place Services at Essex County Council, prior to the start of the fieldwork. Oxford Cotswold Archaeology was commissioned as Balfour Beatty's archaeological contractor to undertake the evaluation in accordance with the approved WSI and local and national planning policies.
- 1.1.4 The fieldwork in Land Parcel 2 was completed between 7th and 16th October 2020. All work followed the MoRPHE Project Manager's guide (Historic England 2015), and the Code of Conduct of the Chartered Institute for Archaeologists (CIfA). The archaeological works adhered to the standards and guidance for archaeological evaluation, excavation and archiving (CIfA 2014a; 2014b).
- 1.1.5 The work was monitored by Richard Havis and Katie Lee-Smith of Place Services on behalf of the Borough of Thurrock.

## 1.2 Location, topography and geology

- 1.2.1 Land Parcel 2 is located c 30m north of the hamlet of Orsett Heath (Fig. 1) within the county of Essex and Thurrock unitary authority (NGR 564047 180101). The land parcel is sub-square in shape and covers an area of 7.8ha. It is also located 600m south of the A13 and 120m east of the A1089. Heath Road is c 70m west of the site and several houses front onto this road. The parcel is bounded to the north and east by other agricultural fields, to the south by Hornsby Lane and houses and small fields north of Gowers Lane and to the west by scrubland and houses east of Heath Road.
- 1.2.2 The bedrock geology is Thanet Formation (sand). The whole site is covered by superficial geology of the Boyn Hill Gravel Member (sand and gravel) which was formed in the Quaternary Period up to 2 million years ago (BGS 2020).
- 1.2.3 This land parcel is currently in use as one large and three small pastoral fields. Within the 1km site buffer the land use is a mixture of agricultural land and urban development associated with the town of Grays to the south-west, Orsett Heath and Chadwell St Mary to the south and the hamlet of Baker Street to the north-west. The area has also been bisected by the A13, A1013 and the A1089, which have displaced the historical field boundaries.
- 1.2.4 This land parcel is situated on an upland area to the south of Orsett. The land parcel itself is gently sloped, with the southern edge at c 24-25m OD sloping down to the north-east at 20-21m OD. No permanent streams are marked in the immediate vicinity of the site, but just beyond the north-east corner of the site the land drops gradually into the end of a dry valley, so that the field drains in this direction. The Mar Dyke valley lies 1.6km to the north-west, and this is the nearest large river to the site. There is also a drainage ditch located 1.3km east of the land parcel at Brook Farm. This watercourse may have originated in the now dry valley just east of the land parcel and flowed eastwards towards the Mucking Marshes.

## 1.3 Previous investigations

- 1.3.1 No known below-ground archaeological investigation has been undertaken within this land parcel. The only modern development in the vicinity of the site was the construction of several early 20th century houses directly west of and outside the site.

## 1.4 Archaeological and historical background

- 1.4.1 The chronological summary of known archaeology given below is taken from the detailed WSI B for Land Parcel 2.
- 1.4.2 **Palaeolithic.** A number of Palaeolithic finds have been recorded 0.4-0.6km south and south-west of Land Parcel 2 and outside the area of the scheme including a Palaeolithic handaxe and Palaeolithic flint flakes. Palaeolithic finds have also been identified 0.5km east of Land Parcel 2 and just east of the scheme including four handaxes, one retouched flake and nine flakes.
- 1.4.3 **Mesolithic.** Mesolithic finds spots have been recorded 0.4-0.6km east of Land Parcel 2 and within the area of the scheme. Mesolithic finds have also

been recorded 0.4-0.6km south of Land Parcel 2 and outside the area of the scheme.

- 1.4.4 **Neolithic.** A scheduled early Neolithic causewayed enclosure (SM 1009286) is located 1km east of the land parcel, and findspots of Neolithic flints are recorded just north-west of this. Neolithic flints have also been recorded across several fields 0.4-0.6km south-east of the site on the boundary of the scheme area. A cropmark of a narrow rectangular enclosure aligned east-west with rounded ends is recorded directly east of Land Parcel 2, and from its morphology this is suspected to be a mortuary enclosure of Neolithic date. It is possible that features associated with this monument extend westwards into the area of the site.
- 1.4.5 **Bronze Age.** The cropmark of a possible ring ditch which may well represent a ploughed-out round barrow was identified 0.35km north of Land Parcel 2 (Aerial Investigations and Mapping Report site 21), and two others some 0.75km to the east. Land Parcel 2 is located 1km south-east of the Orsett (Grey Goose Farm) Cropmark Complex (SM 1002134). This is a scheduled monument that comprises an extensive and dense multi-period site. It includes two adjacent circular ring ditches on the edge of the terrace which may represent early Bronze Age barrows (Aerial Investigation and Mapping Report 13, 14 and 15). The A13 passes through the southern part of the cropmark complex, and this revealed discrete features of late Bronze Age date.
- 1.4.6 **Iron Age.** The Neolithic causewayed enclosure (SM 1009286) located 1km east of the site was overlain by an unenclosed early Iron Age site and a middle Iron Age sub-rectangular enclosure (Hedges and Buckley 1978, 219-308). Cropmarks including pits, linears and ring ditches extend from the area of the scheduled early Iron Age enclosure both south-east towards and north-west (Aerial Mapping Report sites 17A, 17B and 72).
- 1.4.7 A large quantity of high-status Iron Age material was recovered by metal detectorists from a field 0.5km east of the land parcel and within the area of the scheme. This findspot may have been located within an extensive rectilinear enclosure located c 100m east of the land parcel (discussed below). Two Iron Age vessels were also found 0.8km north of the land parcel, just outside the area of the scheme.
- 1.4.8 **Roman period.** One Roman site and several possible Roman sites lie on the gravel ridge 1-1.5km north-west of Land Parcel 2. These comprise a late Iron Age to late Roman farmstead, the multi-period scheduled Orsett (Grey Goose Farm) Cropmark Complex (SM 1002134), and another possible Roman enclosure just to the east of it.
- 1.4.9 An extensive cropmark complex that includes one very large rectilinear enclosure and several smaller ones linked by trackways or field boundaries was identified by the aerial survey c 100m east of the land parcel (Aerial Investigations and Mapping Report site 20). The large enclosure is on a north-west to south-east alignment and contains sub-divisions, pits and curvilinear smaller enclosures. Another trackway is evident a little further south leading SSE to a further cropmark enclosure south of the scheme, which was characterised as late Iron Age or Roman (Priddy and Buckley

1987). It is likely that some elements of this extensive cropmark complex are of Roman date.

- 1.4.10 **Medieval period.** Middle Saxon activity has been identified east and north-east of the land parcel. The Orsett causewayed enclosure (SM 1009286) was reused as a Saxon funerary monument in the 7th-8th century. A Saxon settlement was also located 1.5km north-east of the land parcel at Orsett Cock.
- 1.4.11 A dense pattern of pits of varying size and shape are dispersed across the Orsett Cropmark Complex (SM 1002134, Aerial Investigation and Mapping Report, sites 13-14) located 1.1km north-west of the land parcel. Some of the pits are elongated in shape and these were thought likely to represent Saxon *grubenhäuser* (sunken-featured buildings) (Place Services 2019). However, excavations directly to the south of the monument indicated that some of these features identified as pits by cropmark interpretation were of geological origin. Saxon artefacts were, however, recorded in some features, demonstrating that there may have been a Saxon settlement in the vicinity. Evaluations completed as part of this scheme have demonstrated that the possible pits are largely of a geological origin.
- 1.4.12 In the late Saxon and later medieval period the land parcel was located within the parish of Orsett. The nucleated medieval settlement of Orsett was located 1.5km north-east of the land parcel. It is likely that in the later medieval period the land parcel was used as agricultural land associated with this settlement. A number of roughly north-south aligned droveways have been observed as cropmarks within the wider area and these may have been used to take livestock to and from the marshland to the upland ridge.
- 1.4.13 **Post-medieval period.** Documentary evidence indicates that in the later post-medieval period the land parcel was situated c 400m to the south of an NE-SW road from Stifford to Stanford. It was also located east of a NNW-SSE-aligned road from the hamlet of Baker Street to Chadwell St Mary. The 1805 first edition OS map indicates that there may have been several houses along the Chadwell road, just west of the land parcel. The Grade II-listed 18th century Whitecrofts Farmhouse is located immediately east of the land parcel. In the early 19th century this farm was known as Heathers and is shown on the Orsett tithe map of c 1840.
- 1.4.14 In the later post-medieval period, the land parcel was used as agricultural land associated with Heathers (later Whitecrofts Farmhouse). This is indicated by the Orsett tithe apportionment of c 1840 which labels two fields within the site as 198 and 199 belonging to Samuel Newcome of Heathers. A NNW-SSE field boundary indicated on the c 1840 the map divided Land Parcel 2 into two fields but this field boundary was removed by the later 19th century. The aerial survey did not reveal any features within the land parcel, but this NNW-SSE field boundary may exist below ground.

## 2 Project Aims

---

### 2.1 General aims

2.1.1 The general aims of the project were as follows:

- i. To establish the presence or absence of archaeological remains along the line of the scheme, and the extent of any areas where remains appear likely to be absent.
- ii. In areas where archaeological remains are known or suspected, to clarify the reliability of the cropmark or geophysical survey evidence.
- iii. In areas where no archaeological remains are indicated by aerial or geophysical survey, to clarify whether this apparent absence of remains is genuine.
- iv. To determine the degree of complexity of any surviving horizontal or vertical stratigraphy, and in particular, to investigate areas where topography indicates the likelihood of deep deposit sequences for evidence of buried archaeological horizons and palaeo-environmental sequences.
- v. Where remains are present, to determine the period(s) represented, the extent, state of preservation and character of the archaeological remains.
- vi. To establish the range and state of preservation of archaeological artefacts, and through their recovery and examination, to establish the potential for information about the economy, status and contacts of past inhabitants of the scheme footprint.
- vii. To determine whether palaeo-environmental remains are preserved, and, where these are found, to determine their types (e.g. charred plant remains, waterlogged remains, molluscan remains), state of preservation and potential for environmental information. This will be achieved through the recovery of samples from sedimentary sequences and archaeological features suitable for assessment of a range of palaeoenvironmental remains (e.g. charred and waterlogged plant remains, charcoal, insects, pollen, diatoms, ostracods/foraminifera and molluscs) and scientific dating (e.g. radiocarbon and OSL dating).
- viii. To investigate and record the extent, character and chronology of the sedimentary sequences, in particular those immediately adjacent to and in floodplains, contained within palaeochannels or in dry valleys, and to use the data to refine existing geoarchaeological (predictive) deposit models.
- ix. To place any identified archaeological remains into their local and, where appropriate, regional or national context, and to assess the implications of any such discoveries for our current understanding of settlement and landscape change in the area, including an assessment of the associations of any remains with reference to the historic landscape.
- x. To provide sufficient information to enable the LTC archaeological advisor, in consultation with the key archaeological stakeholders, to determine the significance of the archaeological assets identified within the land parcel.

- xi. To provide a report on the discoveries to inform the Environmental Statement (ES) supporting the Development Consent Order (DCO) and support the preparation of a further archaeological mitigation strategy for the Enabling Works and Construction phases of the scheme.
- xii. Following the DCO, to deposit the report in the public domain, and to generate an accessible and useable archive which will allow future research to be undertaken.

## 2.2 Specific objectives

2.2.1 The specific project objectives were as follows:

- xiii. To conduct the programme of archaeological investigation within the general research parameters and objectives defined by the revised East of England Research Framework (Medlycott 2011), and to take account of the aims and objectives of the Greater Thames Estuary Historic Environment Research Framework.
- xiv. To establish the location of any 'islands' that may have been favoured areas for activity in the past and their longevity.
- xv. In the Mar Dyke valleys, to establish the sequence and character of deposits across the valleys, and date them by means of artefacts or scientific dating.
- xvi. To clarify the changing extent of the alluviated area over time, and look for evidence of agriculture, settlement or burials that might support the evidence of the sediments themselves.
- xvii. To look for buried archaeological horizons within the colluvial sequence.
- xviii. For the late Upper Palaeolithic, Mesolithic and Neolithic periods, to investigate landscape processes, and in particular, the potential for sites being eroded and buried beneath colluvium or Head deposits at the foot of slope areas (Aims C.6 and C.7), and for the survival of undisturbed occupation surfaces below colluvium or beneath later alluviation in the Mar Dyke and Thames floodplains.
- xix. To investigate activity carried out around causewayed enclosures and burial monuments of the Neolithic and early Bronze Age, whether peripheral burial, deposits related to visits, or reuse for burial or other purposes in later periods.
- xx. To clarify whether the cropmarks provide an accurate representation of the range, quantity and types of archaeological features present within the parcel.
- xxi. To establish the character and date of the extensive pits across the land parcel, and to determine whether these are all of one type or period, or whether they encompass several types and span several periods of activity.
- xxii. To establish the date of the possible medieval or post-medieval field boundaries that have been identified within the land parcel.
- xxiii. To establish whether a possible medieval droveway extends northwards through the land parcel.

- xxiv. To look for evidence of medieval and post-medieval farmsteads which may have been located along the roadways within the northern and western part of the land parcel.



## 3 Methodology

---

### 3.1 Constraints

- 3.1.1 Several constraints have limited the area of the land parcel available for trial trenching. This includes services, Unexploded Ordnance (UXO) and ecological constraints. The Principal Contractor Balfour Beatty was responsible for ensuring that the constraints were observed through the Permit to Dig system.
- 3.1.2 **Services.** Two overhead lines bisect the northern part of the land parcel and are aligned WNW-ESE. The base of one of these pylons is located at the north-western boundary of the site and one base is also located at the south-eastern extent of the site. There is also a UK Power Network Extra High Voltage power line located along the northern and eastern edge of the site and this also bisects the south-eastern corner of the site.
- 3.1.3 **Unexploded Ordnance (UXO).** The UXO survey classified the site as having a moderate potential for unexploded ordnance. In addition, the survey mapped the site of one high explosive and one unexploded bomb within the southern part of the land parcel. The trenches were designed to avoid the immediate area of risk, but the location cannot be regarded as very accurate. Guidance as to the procedures to be followed were provided by a specialist firm qualified in the detection and removal of UXO. No archaeological trenching was allowed to take place until the appropriate surveys were undertaken. In addition, a specialist was present on site throughout the laying out and machine excavation of the trenches.
- 3.1.4 **Ecological constraint.** Three badger setts were present within the site boundary. One was located on the northern boundary and two along the eastern boundary. A 30m buffer was established around the badger setts where no trial trenches were excavated.
- 3.1.5 These constraints were taken into account (as far as is practicable) when drawing the detailed trench layout for the land parcel (Fig. 2). Exclusion zones were generally applied for services encountered throughout the project as follows: gas main (30m), high voltage (HV) overhead power lines (15m), buried HV electrical mains (10m), lower voltage electrical services (5m), water mains (5m).
- 3.1.6 It was necessary to adjust the locations of several trenches within Land Parcel 2 immediately prior to excavation as a result of low-hanging overhead cables and the variation between the plotted and actual buried services. Six trenches were also omitted from the evaluation where these coincided with low overhead cables.

### 3.2 Methodology for the evaluation

- 3.2.1 The total land parcel area was 7.8ha, and the area available for investigation excluding areas of services, hedgerows and other constraints was 7.07ha. A total of 41 trenches were excavated, with all trenches measuring 30m x 2m. Combined, these represent a 4% sample of the area available for trenching. The location of the trenches is shown on Figure 2.

- 3.2.2 The trench design was developed to provide even coverage of the blank areas, but also to target the continuations of linear features that run towards this land parcel from adjacent fields, such as a trackway, and to target the vicinity of the possible Neolithic mortuary enclosure identified in Land Parcel 3.
- 3.2.3 All trenches were located using a Global Positioning System (GPS) prior to machine excavation. All trenches were excavated using a tracked excavator fitted with a toothless bucket being operated under constant archaeological supervision.
- 3.2.4 Revealed features were hand cleaned and sampled by hand excavation. They were recorded as outlined within the approved WSI. All finds were bagged by context throughout the evaluation and were recovered for further investigation, and soil samples were taken as appropriate.

## 4 Results

---

### 4.1 Introduction and presentation of results

- 4.1.1 The results of the evaluation are presented below and include a stratigraphic description of the trenches that contained archaeological remains. The full details of all trenches with dimensions and depths of all deposits can be found in Appendix A. Finds and environmental data are presented in Appendices B and C respectively.
- 4.1.2 Context numbers reflect the trench numbers, unless otherwise stated. The first numerals of a context number repeat the trench number whilst allowing for a maximum range of 100 individual records for any one trench. For example, ditch 603 is a cut within Trench 6, while pit 2703 is a cut within Trench 27. Also Trench 6 has a potential record number range of 600-699, while Trench 27 has a range of 2700-2799.
- 4.1.3 An overview of the results for the site is shown on Figure 2. Further detailed plans of the trenches which contained archaeological features are shown on Figures 3, 4, and 6 and selected sections are shown in Figures 5 and 7.

### 4.2 General soils and ground conditions

- 4.2.1 The soil sequence consists of natural geology of sand, overlain by a sandy silt subsoil, which in turn was overlain by ploughsoil.
- 4.2.2 The ploughsoil ranged between 0.18m and 0.38m thick and consisted of dark – mid brownish grey sandy silt and silty clay.
- 4.2.3 The subsoil deposits ranged between 0.12m and 0.30m thick across the site. The subsoil is likely to represent the remains of a former ploughsoil which now lies beneath the current ploughsoil.
- 4.2.4 Ground conditions throughout the evaluation were generally good, and the site remained largely dry throughout. Archaeological features, where present, were easy to identify against the underlying natural geology.

### 4.3 General distribution of archaeological deposits

- 4.3.1 Archaeological features were identified in 17 trenches (Trenches 6, 8-11, 14, 24-27, 31-33, 35-37 and 43), with activity centred on a band running NW-SE across the centre of the land parcel and in the north of the site.
- 4.3.2 Trenches 2, 4, 17, 28 and 34 contained only natural features and these were all tested with hand excavation.
- 4.3.3 A total of 19 trenches contained no features of any kind (Trenches 1, 3, 12, 13, 15, 16, 20-23, 29, 30, 38-42, 44 and 47). Blank trenches are not described or illustrated in detail.
- 4.3.4 The evaluation confirmed the presence of several linear and curvilinear features within the site, as well as discrete features.

## 4.4 Trenches 8-11, Northern cluster (Fig. 3)

- 4.4.1 Trenches 8-11 were located in the north-east of the site, north of the overhead cables crossing Land Parcel 2 (Fig. 2). None of the features in this area of site revealed finds or dating evidence.
- 4.4.2 Cropmarks of the surrounding land parcels suggested that linear features there might continue into Land Parcel 2 here, but none were found in any of the trenches.
- 4.4.3 **Trench 8.** Trench 8 lay within the north-west edge of Land Parcel 2, north of the overhead exclusion zone (Fig. 3). One ditch, 803, runs NNW-SSE in the centre of the trench. The ditch measured 0.62m wide and 0.2m deep, had moderately sloping sides and a concave base. No finds were recovered from the single fill.
- 4.4.4 **Trench 9.** Trench 9 was positioned south-east of Trench 8 and south of Trench 10 (Fig. 3). Pit 903 was encountered within the north-west side of the centre of the trench. This was circular in plan, measuring 0.86m wide and 0.32m deep, and had gradual sloping sides and a concave base. No finds were recovered from the single fill.
- 4.4.5 **Trench 10.** Trench 10 was positioned north of Trench 9 and east of Trench 8 (Fig. 3). One small pit, 1003, was identified at the north-east end of the trench. The feature was circular in plan, measuring 0.38m wide and 0.07m deep, with gradual sloping sides and a flat base. The single fill yielded no finds.
- 4.4.6 **Trench 11.** Trench 11 was positioned within the northernmost corner of Land Parcel 2, east of Trench 10 (Fig. 3). Pit 1103 was recorded at the northern end of the trench and measured 0.82m wide and 0.24m deep. It was circular in plan with sloping sides and a concave base. This contained a single sterile fill. A natural feature, 1105, was also recorded.

## 4.5 Trenches 4 and 6 (Figs 4 & 5)

- 4.5.1 **Trenches 4 and 6** were positioned immediately south of the exclusion zone for the overhead cables, on the west side of Land Parcel 2. Trench 4 was on the western edge of site and Trench 6 was to the east of Trench 4. Trenches 4 and 6 revealed a large natural hollow at the western end of both trenches (Fig. 4). In both trenches the feature was excavated by machine: in Trench 4, 403 was found to be 12m wide and 0.76m deep and have two fills, one of which produced a possible quern or sharpening stone (see Appendix B). In Trench 6, 605 was 10m wide and 0.31m deep with a single fill (Fig. 5, section 600; Plate 1), producing no finds. Both features were flat-based, had shallow sloping sides and appeared irregular in plan.
- 4.5.2 Trench 6 also exposed a ditch, 603, which was aligned NE-SW. It had steep sides and a flat base, measured 1.60m wide and 0.20m deep, and had a single fill, 604, which contained one piece of worked flint.

## 4.6 Trench 14 (Figs 4 & 5)

- 4.6.1 **Trench 14** lay to the west and south of the main group of trenches described above and below, and was surrounded by blank trenches (Fig. 4). The trench contained one pit, 1403, at the SW end. The feature was

circular in plan and measured 0.41m wide and 0.23m deep. It had moderately sloping sides and a concave base (Fig. 5; Plate 2). It contained one fill, 1404, which contained flecks of charcoal and three sherds of early Neolithic pottery. An environmental sample (Sample 1) was taken, and produced charcoal, grain and weed seeds in small quantities.

#### 4.7 Trenches 24 – 27, 31, 32, 36 and 43 (Figs 4 – 7)

- 4.7.1 Trenches 24 – 27, 31, 32, 36 and 43 were located across the centre of Land Parcel 2, arranged in numerical order from WNW-ESE (Figs 4 & 6).
- 4.7.2 **Trench 24.** Trench 24 lay SSW of Trench 6 (Fig. 4). It contained two small pits at the northern end, and a ditch orientated ENE-WSW in the centre of the trench. Ditch 2403 was possibly a boundary ditch, although a continuation cannot be determined in any of the surrounding trenches. The ditch was 1.60m wide and 0.62m deep, with moderate-steep sloping sides and a concave base. The ditch had three fills which revealed no finds.
- 4.7.3 At the northern end of the trench, there were two pits, 2405 and 2407. Pit 2405 was sub-circular, measuring 0.39m wide and 0.08m deep, and had gently sloping sides with a concave base. Pit 2407 was sub-circular, measured 0.47m wide and 0.15m deep, and had moderately sloping sides and a concave base. Both pits contained single sterile fills.
- 4.7.4 **Trench 25.** Trench 25 was positioned to the north-east of Trench 24 (Fig. 4). There was a single ditch, 2503, aligned NE-SW, at the west end of the trench, which was not seen in any of the surrounding trenches. Ditch 2503 was 0.92m wide and 0.40m deep, had steep sides and a concave base and contained two fills (Fig. 5, section 2500; Plate 3). The basal fill contained seven sherds of probable prehistoric pottery. The subsoil from Trench 25 yielded a sherd of post-Roman pottery dating to c AD 900-1250.
- 4.7.5 **Trench 26.** Trench 26 was to the immediate north-east of Trench 25 (Fig. 6). It contained five pits and a ditch, and one unexcavated feature which was a potential posthole. Close to the unexcavated feature was a natural feature which was tested through hand excavation.
- 4.7.6 At the south-east end of the trench was a pit, 2603, which was sub-oval in plan and measured 0.5m wide and 0.06m deep. The pit had shallow sides with a concave base and contained one fill which provided no finds.
- 4.7.7 Ditch 2605 was aligned north-south within the north-west end of the trench and was 0.86m wide and 0.4m deep. This had steep sloping sides with a shallow concave base, and two fills which contained no finds. There is no clear continuation of the ditch in surrounding trenches.
- 4.7.8 Further NW were Two intercutting pits (2610 and 2608) were present to the north-west of ditch 2605. The fill of pit 2610 was cut by 2608 (Fig. 7, section 2602; Plate 4). Pit 2608 was ovoid in plan and continued beyond the northern edge of the trench. It measured 0.9m wide and the sides were steeply sloping, but the full depth was not reached within the part of the feature exposed within the trench. Two fills were recorded, although neither of these yielded any finds. The pit is likely to be modern, as it was cut through the subsoil horizon (2601). The earlier pit, 2610, was irregularly ovoid in plan and measured 0.77m wide and 0.28m deep with moderately

sloping sides and a shallow concave base. There was one fill which yielded eight sherds of middle Bronze Age – early Iron Age pottery.

- 4.7.9 Pit 2615 was recorded within the south-eastern half of the trench and west of pit 2603. This was an irregular oval shape in plan and measured 1.8m wide and 0.5m deep with shallow sloping sides and a shallow concave base. It contained two fills which produced no finds. The pit continued beyond the south-west edge of the trench.
- 4.7.10 Feature 2617 was located between 2605 and 2615. Hand excavation confirmed that this was a natural feature. A possible posthole (2612) was recorded to the north of feature 2617 but was not excavated.
- 4.7.11 **Trench 27.** Trench 27 was to the north-east of Trench 26 (Fig. 6). The trench revealed three pits (2703, 2705, 2711), a ditch (2707) and a natural feature (2709) which was also investigated by hand.
- 4.7.12 At the centre of the trench was pit 2703, which was circular in plan, and measured 0.93m wide and 0.26m deep (Fig. 7, section 2700; Plate 5). The pit had a rounded profile and contained a single fill. This was fully excavated and an environmental sample (Sample 2) was taken due to the presence of charcoal and pottery from two or three Beakers. Two fragments of fired clay were also recovered, which are consistent with debris from domestic ovens or hearths. The environmental sample produced only charcoal.
- 4.7.13 Immediately east of 2703 was posthole 2705, which was circular in plan and measured 0.5m wide and 0.07m deep (Fig. 7, section 2700; Plate 5). The sides were shallow and the base concave, and the feature contained one fill which contained no finds. The posthole and pit could be related, though the lack of dating from the posthole means that this remains uncertain.
- 4.7.14 To the west was N-S-aligned ditch [2707]. The feature had moderately sloping sides with a concave base and measured 1.70m wide and 0.3m deep. The single fill included no finds.
- 4.7.15 A pit or possible ditch terminus (2711) was excavated within the south-west end of the trench. The entire shape was not seen in plan as it continued beyond the edge of the trench. The feature was 1m wide and 0.4m deep with almost vertical sides and a flat base. The single fill contained no finds.
- 4.7.16 **Trench 31.** Trench 31 was positioned to the south-west of Trench 24 (Fig. 4). It contained a pit, a posthole and a natural feature which was also excavated by hand. Posthole 3103 was sub-rectangular in plan with steep almost vertical sides and a flat base but no obvious post-pipe. It measured 0.14m wide and 0.12m deep, with a single fill which contained frequent charcoal and baked clay and very fragmentary pieces of possible prehistoric pottery. Pit 3105 was circular in plan and measured 0.96m wide and 0.14m deep, with gradually sloping sides and a flat base. The single fill contained charcoal flecks and highly fragmentary tiny pieces of pottery noted in excavation that were not possible to collect and retain.
- 4.7.17 **Trench 32.** Trench 32 was positioned to the north-east of Trench 31 and south of Trench 24 (Fig. 4). The trench contained one undated NW-SE-aligned ditch (3203) which had gradual sloping sides and a flat base. The

ditch measured 1.30m wide and 0.14m deep and appeared to have been truncated by ploughing.

- 4.7.18 **Trench 36.** Trench 36 was positioned to the south-east of Trench 27 and east of Trench 35 (Fig. 6). Trench 36 had two small pits and three natural features, two of which were investigated through hand excavation.
- 4.7.19 The two pits lay at the SW end of the trench. Pit 3603 was sub-circular and measured 0.73m wide and 0.17m deep, with moderately sloping sides and a concave base. The single fill contained no finds. Pit 3608 lay further west, closer to the end of Trench 36, and extended beyond the edge of the trench. The feature measured 0.68m wide and 0.3m deep, with steep sides and a concave base and had one fill which contained no finds.
- 4.7.20 **Trench 43.** Trench 43 was positioned to the south of Trench 37 on the eastern edge of Land Parcel 2 (Fig. 6). Trench 43 contained a single small posthole or pit which was circular in plan and measured 0.32m wide and 0.14m deep. The single fill yielded no finds.

## 4.8 Trenches 33, 35 and 37 (Figs 4, 6 and 7)

- 4.8.1 Trenches 33, 35 and 37 were all orientated NNW-SSE; Trench 33 is in the centre of Land Parcel 2, Trench 35 lies to the east of 33 and Trench 37 is to the east of Trench 35 (Figs 4 & 6).
- 4.8.2 The trenches all contained two parallel ditches which can be traced across this area of the site and may possibly represent a boundary or driveway. The northern ditches, (3305, 3503 and 3706), range in width from 0.95m to 3.30m and depth 0.14 to 0.75m. The southern ditches, (3305, 3507 and 3703), range in width from 0.78m to 1.25m and depth 0.07m to 0.55m.
- 4.8.3 The fills of the ditches vary, though this may be resultant of the natural geology into which the ditches were cut.
- 4.8.4 **Trench 33.** Trench 33 contained two parallel, NW-SE-aligned ditches (3303 and 3305). Ditch 3303 had gently sloping sides and a concave base and measured 0.78m wide and 0.07m deep, with the single fill producing no finds. Ditch 3305 was north of 3303 and had a similar profile, measuring 1.10m wide and 0.14m deep. The single fill contained two tiny sherds of very abraded prehistoric pottery.
- 4.8.5 **Trench 35.** Trench 35 contained two parallel ditches aligned ENE-WSW, with pit 3505 lying between them. Ditch 3503 lay to the north of pit 3505. The ditch was 3.30m wide but was not bottomed due to excavation being limited to a maximum of 1m below the modern ground level. The sides were steeply sloping and the single fill contained no finds, although it did show some occasional flecks of charcoal. Ditch 3507 measured 1.25m wide and 0.55m deep, with very steep sides and a concave base. The single fill was very similar to that of 3503 and contained no finds.
- 4.8.6 Pit 3505 lay between the two ditches at the centre of the trench. The pit was sub-oval in plan and had gradually sloping sides with a concave base. The pit measured 1.3m wide and 0.2m deep and continued beyond the edge of the trench to the west. The single fill contained no finds.

- 4.8.7 **Trench 37.** Trench 36 contained three ditches and three pits and a posthole. Each of the features were excavated by hand apart from 3719, which was recorded in plan only.
- 4.8.8 At the southern end of the trench were two parallel ditches, (3703 and 3706), both aligned ENE-WSW. Ditch 3703 displayed moderate sloping sides and a concave base and measured 1.25m wide and 0.46m deep; both fills of 3703 contained no finds (Fig. 7, section 3700; Plate 6). North of 3703, ditch 3706 also had moderate sloping sides and a concave base and measured 0.95m wide and 0.36m deep (Fig. 7, section 3701; Plate 7). The ditch had two fills, neither of which produced finds.
- 4.8.9 Pit 3709 was sub-oval in plan and had steeply sloping sides and a flattish base. It measured 1.13m wide and 0.17m deep; its single fill contained no finds.
- 4.8.10 At the north end of the trench was ditch 3712, which was curvilinear and aligned NNW-SSE. It was slightly irregular in plan and measured 1.34m wide but was of unknown depth due to the limit of excavation; the sides were steeply sloping and the two fills contained no finds (Fig. 7, section 3703; Plate 8). Ditch 3712 truncated the fill of a small posthole (3715) on its southern side. The posthole was circular in plan and had steep sloping sides and a concave/flat base (Fig. 7, section 3703; Plate 8). It measured 0.2m wide and 0.12m deep and the single fill contained no dating evidence.
- 4.8.11 Two pits (3717 and 3719) continued beyond the western edge of the trench. Pit 3717 was ovoid in plan and measured 1m wide and 0.3m deep, with moderate sloping sides and a shallow concave base. The single fill contained no finds.

## 4.9 Finds summary

- 4.9.1 **Prehistoric pottery:** The evaluation recovered 26 sherds (122g) of prehistoric pottery from five contexts across five trenches. The assemblage was diverse, representing at least three periods: early Neolithic, middle Bronze Age-early Iron Age and Beaker.
- 4.9.2 **Medieval pottery:** The evaluation recovered one sherd of pottery weighing 18g, which dates to c AD 900-1250.
- 4.9.3 **Fired clay:** Two fragments of fired clay were recovered, though neither are diagnostic nor display any surviving shaped surfaces.
- 4.9.4 **Worked stone:** A single piece of worked stone weighing 420g was recovered. The artefact does not retain any edges but it has been worn flat through use so it could possibly have been used as a quern. A series of grooves also show that this was used as a sharpening stone.
- 4.9.5 **Flint:** A very small assemblage of three struck flints and 10 fragments of unworked burnt flint were recovered during the evaluation

## 4.10 Environmental summary

- 4.10.1 **Charred plant remains and charcoal.** Only two pits contained deposits with environmental potential. The sample from an early Neolithic pit produced charcoal, charred grain and weed seeds, while that from a Beaker pit contained only charcoal.



## 5 Discussion

---

### 5.1 Reliability of field investigation

- 5.1.1 The layout of trenches provided good overall coverage of the site. However, the need to omit 6 trenches due to low overhead cables left small areas uninvestigated (Trenches 5, 7, 18, 19, 45 and 46 were not excavated).
- 5.1.2 The archaeological features were generally clear against the underlying Boyn Hill Gravels, Thanet Sands and Gravels and hill slope deposits. Initially some deposits were sample excavated to establish if they were of geological or archaeological significance, and in several cases, putative archaeological features were shown to be no more than variations in natural deposits of sand or gravel.
- 5.1.3 Though there were no cropmarks available for this site, the trenches which were placed to cover any continuations of cropmarks from surrounding land parcels were blank. This may suggest that this land parcel has been more heavily ploughed and truncated in the past, or simply that the features shown as cropmarks do not continue into those areas.

### 5.2 Interpretation

- 5.2.1 **Neolithic.** One pit of early Neolithic date was revealed in Trench 14, shown through sherds of early Neolithic pottery and worked flint of a possibly similar date. This feature lies c 300m south west of the possible Neolithic mortuary enclosure picked up in the cropmarks in Land Parcel 3, although no proof of a Neolithic date was provided by the evaluation (OCA 2020a). An early Neolithic causewayed enclosure is known in the wider landscape at Orsett 1km to the east (Hedges and Buckley 1978), and Neolithic pits to the south of this lie within the LTC corridor in Land Parcel 4 (OCA 2020b).
- 5.2.2 **Early Bronze Age.** Trench 27 contained sherds of at least two Beakers: one a fine comb-decorated example and the other a coarser example with fingernail decoration. This could represent an isolated pit or be part of a group in the surrounding area, although no other early Bronze Age pits were found by evaluation trenches within Land Parcel 2. Another Beaker pit was found in the west part of Land Parcel 3 some 250m to the east (OCA 2020a). The presence of these vessels could also signify that there was Beaker mortuary activity in the area; a cropmark ring ditch possibly of early Bronze Age date is known 350m to the north, and others in Land Parcels 22 to the north-west (OCA 2020c) and 4 to the east (OCA 2020b) may be of early Bronze Age date.
- 5.2.3 **Middle Bronze Age – Early Iron Age.** Trench 26 contained eight sherds of middle Bronze Age – early Iron Age pottery. No other features contained pottery certainly identified as later prehistoric, though two other pits containing finds only datable as prehistoric may also be of later prehistoric date. Later Bronze Age/early Iron Age activity was identified in the neighbouring Land Parcels 1 and 3 as discrete and linear features (Fig. 1; OCA 2020a and 2020b). Ring ditches seen on the cropmark survey in the wider area could also date from this period.

- 5.2.4 **Medieval.** One sherd of medieval pottery was recovered from subsoil, but no features of this date were identified. The sherd dated to c AD 900-1250, and is from a continental imported vessel of a type unusual to Essex, but more often found in London in the 11th-12th centuries. Its presence here may be related to the proximity of the river Thames.
- 5.2.5 **Post-medieval.** Post medieval activity on the site is not represented through the finds, though there are a number of undated ditches, particularly those on a NNW-SSE or WSW-ENE alignment in Trenches 24, 27, 32, 35 and 37, which could be part of field systems that have only relatively recently gone out of use. The earliest edition OS map shows that the boundary for Land Parcel 2 has not changed in the last hundred years, but the Tithe map of 1840 shows that there was a NNW-SSE division towards the east side of Land Parcel 2, with which the ditch in Trench 27 may well correspond, although no continuation of this was seen in Trench 41 further south.
- 5.2.6 **Features of geological and natural origin.** The site contained a number of discrete sub-circular features which were filled with a fine sandy silt and contained no dating evidence. These were probably natural hollows that have been filled through silting.
- 5.2.7 **Undated.** Many ditches and pits on the site remain undated. All the features in the northern portion of the site are undated and their functions are unclear. The lack of cropmarks for the site makes it difficult to know what these features may amount to, though the density of features in the surrounding trenches and land parcels on the wider scheme to the east could suggest that they are part of field systems.

### 5.3 Evaluation objectives and results

- 5.3.1 The evaluation established the presence of archaeological remains of early Neolithic, Bronze Age and post-Roman date (**aims i-v**). Artefactual evidence was limited but, with the presence of pottery, worked flint, burnt flint, fired clay and a hone (possibly reusing a quern), pointed to domestic and processing activities – cooking, heating and tool use and maintenance and so on – in the vicinity of the site (**aim vi**). Palaeoenvironmental remains were also limited and of variable condition, but the evaluation nevertheless demonstrated potential for the recovery of charred plant remains that offer insight into past activities, including in the Neolithic period (**aim vii**).
- 5.3.2 Turning to the specific aims of the project, no alluvial deposits were revealed (**aim xvi**), nor and colluvium or buried archaeological horizons revealed in this site (**aims xvii & xviii**). For this reason, no information regarding **aim xiv** was evident.
- 5.3.3 No evidence from the Upper Palaeolithic or Mesolithic was found (**aim xviii**).
- 5.3.4 One early Neolithic pit, and one late Neolithic/early Bronze Age pit with Beaker pottery were found, and these form part of a wider landscape of earlier prehistoric activity that includes the causewayed enclosure and possible burial monument identified in the cropmark survey (**aim xix**).

- 5.3.5 The land parcel had no associated cropmarks, though some trenches were targeted on possible continuations of features from Land Parcels 1 and 3 (**aim xx**). However, these features were not found to continue, which may suggest that Land Parcel 2 had been more heavily ploughed in the past or was not part of the field systems seen in the cropmarks. The features which have been identified in the trenches suggest that, notwithstanding the absence of cropmarks, this area had a relatively low level of activity throughout the past.
- 5.3.6 The area of pits seen in the cropmark survey of Land Parcel 3 appears to have continued into south-eastern side of Land Parcel 2 (**aim xxi**). The pits from which dating evidence was recovered all date between the Neolithic period and early Iron Age, and confirm the presence of activity of these periods within the investigation area.
- 5.3.7 The evaluation found a number of possible boundaries, although they cannot be assigned to the medieval or post-medieval periods with confidence, as their dating is unclear (**aim xxii**). The only sherd of medieval pottery was found in subsoil. While no medieval driveway was identified on the site extending northwards (**aim xxiii**), evidence for a possible trackway, aligned roughly NW-SE, was uncovered. However, its dating is presently uncertain, as just one piece of prehistoric pottery was recovered from it. No evidence for medieval or post-medieval farmsteads was recovered (**aim xxiv**).

# Appendix A Trench Tables

<b>Trench 1</b>							
General description					Orientation		NE-SW
Trench devoid of archaeology. Consists of ploughsoil and subsoil overlying natural geology of clayey sand.					Length (m)		30
					Width (m)		2
					Avg. depth (m)		0.5
Context No.	Type	Fill Of	Width (m)	Depth (m)	Description	Finds	Date
100	Layer		2	0.28	Ploughsoil. Dark brownish grey, clayey silt, soft		
101	Layer		2	0.2	Subsoil. Mid greyish brown, clayey silt, soft		
102	Layer		2		Natural. Light yellowish brown, clayey sand, soft		
<b>Trench 2</b>							
General description					Orientation		NW-SE
Trench devoid of archaeology. Consists of ploughsoil and subsoil overlying natural geology of clayey sand.					Length (m)		30
					Width (m)		2
					Avg. depth (m)		0.42
Context No.	Type	Fill Of	Width (m)	Depth (m)	Description	Finds	Date
200	Layer		2	0.22	Ploughsoil. Dark brownish grey, clayey silt, soft		
201	Layer		2	0.2	Subsoil. Mid greyish brown, clayey silt, soft		
202	Layer		2		Natural. Light yellowish brown, clayey sand, firm		
203	Cut		1.03	0.07	Natural Feature. Kidney shaped natural feature. Light brownish grey, sandy silt, soft.		
<b>Trench 3</b>							
General description					Orientation		NE-SW
Trench devoid of archaeology. Consists of ploughsoil overlying subsoil and natural of clayey sand					Length (m)		30
					Width (m)		2
					Avg. depth (m)		0.48
Context No.	Type	Fill Of	Width (m)	Depth (m)	Description	Finds	Date
300	Layer		2	0.36	Ploughsoil. Dark brownish grey, clayey silt, soft		
301	Layer		2	0.12	Subsoil. Mid greyish brown, clayey silt, soft		

302	Layer		2		Natural. Light yellowish brown, clayey sand, firm		
<b>Trench 4</b>							
General description					Orientation		NW-SE
Trench revealed a large natural hollow. Consists of ploughsoil and subsoil overlying natural geology of clayey sand.					Length (m)		30
					Width (m)		2
					Avg. depth (m)		0.58
Context No.	Type	Fill Of	Width (m)	Depth (m)	Description	Finds	Date
400	Layer		2	0.24	Ploughsoil. Dark brownish grey, clayey silt, soft		
401	Layer		2	0.2	Subsoil. Mid greyish brown, clayey silt, soft		
402	Layer		2		Natural. Light yellowish brown, clayey sand, firm		
403	Cut		12	0.76	Natural Feature. Machine excavated		
404	Fill	403	3.94	0.34	Secondary Fill. Light brownish grey, silty sand, compact	Stone	
405	Fill	403	5	0.4	Secondary Fill. Dark reddish brown, clayey silt, soft		
<b>Trench 5 – not excavated</b>							
<b>Trench 6</b>							
General description					Orientation		E-W
Trench contains one ditch and a natural feature. Consists of ploughsoil overlying subsoil and natural of clayey sand.					Length (m)		30
					Width (m)		2
					Avg. depth (m)		1
Context No.	Type	Fill Of	Width (m)	Depth (m)	Description	Finds	Date
600	Layer		2	0.28	Ploughsoil. Dark brownish grey, clayey sand, soft		
601	Layer		2	0.18	Subsoil. Mid greyish brown, sandy silt, soft		
602	Layer		2		Natural. Light yellowish brown, clayey sand, firm		
603	Cut		1.6	0.2	Ditch		
604	Fill	603	1.6	0.2	Secondary Fill. Mid brownish grey, sandy clay, firm	Flint	Residual
605	Cut		10	0.31	Natural Feature. Only seen in section-machine slot		

606	Fill	605	10	0.31	Secondary Fill. Mid brownish grey, sandy clay, firm		
<b>Trench 7 – not excavated</b>							
<b>Trench 8</b>							
General description					Orientation		NE-SW
Trench revealed one ditch. Consists of ploughsoil and subsoil overlying natural geology of gravel and silty sand.					Length (m)		30
					Width (m)		1.95
					Avg. depth (m)		0.5
Context No.	Type	Fill Of	Width (m)	Depth (m)	Description	Finds	Date
800	Layer			0.33	Ploughsoil. Mid greyish brown, sandy silty clay, soft.		
801	Layer			0.22	Subsoil. Mid brownish orange, sandy silty, compact.		
802	Layer			0.55	Natural. Mottled mid brownish orange gravel with light greyish yellow sandy patches.		
803	Cut		0.62	0.2	Ditch		
804	Fill	803	0.62	0.2	Primary Fill. Loose, mid orangish brown, sandy gravel		
<b>Trench 9</b>							
General description					Orientation		NE-SW
Trench revealed one pit. Consists of ploughsoil and subsoil overlying natural of gravel and silty sand.					Length (m)		30
					Width (m)		1.95
					Avg. depth (m)		0.6
Context No.	Type	Fill Of	Width (m)	Depth (m)	Description	Finds	Date
900	Layer			0.38	Ploughsoil. Dark blackish grey, silty clay, soft.		
901	Layer			0.2	Subsoil. Mid orangish brown, sandy silt, loose.		
902	Layer			0.58	Natural. Mottled mid brownish orange, sandy gravel with light greyish yellow sand patches. Loose.		
903	Cut		0.86	0.32	Pit		
904	Fill	903	0.86	0.32	Primary Fill. Soft, mid orangish brown, sandy silt		

<b>Trench 10</b>							
General description					Orientation		NE-SW
Trench revealed one posthole. Consists of ploughsoil and subsoil overlying natural geology of gravel and silty sand.					Length (m)		30
					Width (m)		1.95
					Avg. depth (m)		0.5
Context No.	Type	Fill Of	Width (m)	Depth (m)	Description	Finds	Date
1000	Layer			0.3	Ploughsoil. Mid greyish brown, sandy silt, loose, frequent sub angled stones.		
1001	Layer			0.2	Subsoil. Mid orangish brown, gravely sandy silt, loose		
1002	Layer			0.5	Natural. Dark mottled orangish brown, frequent gravel with sandy patches, loose		
1003	Cut		0.32	0.07	Pit		
1004	Fill	1003	0.32	0.07	Primary Fill. Dark greyish black, sandy silt, soft		
<b>Trench 11</b>							
General description					Orientation		NW-SE
Trench revealed one pit and one treethrow. Consists of ploughsoil and subsoil overlying natural geology of gravel and silty sand.					Length (m)		30
					Width (m)		1.95
					Avg. depth (m)		0.6
Context No.	Type	Fill Of	Width (m)	Depth (m)	Description	Finds	Date
1100	Layer			0.34	Ploughsoil. Mid greyish black, loose, sandy silt, moderate sub angled stones.		
1101	Layer			0.18	Subsoil. Dark orangish brown, loose, sandy, silty gravel.		
1102	Layer				Natural. Mid yellowish brown, sandy gravel, loose.		
1103	Cut		0.82	0.24	Pit		
1104	Fill	1103	0.82	0.24	Primary Fill. Lightly compact, mid greyish brown, sandy gravel		
1105	Cut		1.8	0.24	Tree Throw. Mid greyish brown, silty sand, soft		
<b>Trench 12</b>							
General description					Orientation		NW-SE
					Length (m)		30
					Width (m)		1.95

Trench devoid of archaeology. Consists of ploughsoil and subsoil overlying natural geology of gravel and silty sand.					Avg. depth (m)	0.5	
Context No.	Type	Fill Of	Width (m)	Depth (m)	Description	Finds	Date
1200	Layer			0.3	Ploughsoil. Mid brownish grey sandy silt.		
1201	Layer			0.2	Subsoil. Light brownish grey sandy silt with frequent gravel.		
1202	Layer				Natural. Gravel with patches of orangey silty sand.		
<b>Trench 13</b>							
General description					Orientation		NW-SE
Trench devoid of archaeology. Consists of ploughsoil and subsoil overlying natural geology of sandy clay and gravel.					Length (m)		30
					Width (m)		2
					Avg. depth (m)		0.52
Context No.	Type	Fill Of	Width (m)	Depth (m)	Description	Finds	Date
1300	Layer		2	0.22	Ploughsoil. Dark brownish grey, clayey silt, friable		
1301	Layer		2	0.3	Subsoil. Mid greyish brown, clayey silt, soft.		
1302	Layer		2		Natural. Light yellowish brown, sandy gravel, loose		
1303	Layer		2	0.2	Subsoil. Light yellowish brown, clayey gravel, firm		
<b>Trench 14</b>							
General description					Orientation		NE-SW
Trench revealed one pit. Consists of ploughsoil and subsoil overlying natural geology of clayey sand.					Length (m)		30
					Width (m)		2
					Avg. depth (m)		0.4
Context No.	Type	Fill Of	Width (m)	Depth (m)	Description	Finds	Date
1400	Layer		2	0.2	Ploughsoil. Dark brownish grey, clayey silt, soft		
1401	Layer		2	0.2	Subsoil. Mid greyish brown, clayey silt, soft		
1402	Layer		2		Natural. Light yellowish brown, clayey sand, firm		
1403	Cut		0.41	0.23	Pit		
1404	Fill	1403	0.41	0.23	Primary Fill. Soft, mottled mid greyish brown, silty clay	Pot, Flint	Early Neolithic



							pot, Neo-EBA flint
<b>Trench 15</b>							
General description					Orientation		NW-SE
Trench devoid of archaeology. Consists of ploughsoil overlying subsoil and natural geology of sandy clay.					Length (m)		30
					Width (m)		2
					Avg. depth (m)		0.5
Context No.	Type	Fill Of	Width (m)	Depth (m)	Description	Finds	Date
1500	Layer		2	0.3	Ploughsoil. Dark brownish grey, clayey silt, soft		
1501	Layer		2	0.18	Subsoil. Mid greyish brown, clayey silt, soft		
1502	Layer		2		Natural. Light reddish brown, sandy clay, firm		
<b>Trench 16</b>							
General description					Orientation		NE-SW
Trench devoid of archaeology. Consists of ploughsoil and subsoil overlying natural geology of sandy clay.					Length (m)		30
					Width (m)		2
					Avg. depth (m)		0.5
Context No.	Type	Fill Of	Width (m)	Depth (m)	Description	Finds	Date
1600	Layer		2	0.36	Ploughsoil. Dark brownish grey, clayey silt, soft		
1601	Layer		2	0.16	Subsoil. Mid greyish brown, clayey silt, soft		
1602	Layer		2		Natural. Mid reddish brown, sandy clay, firm		
<b>Trench 17</b>							
General description					Orientation		NE-SW
Trench revealed three natural features. Consists of ploughsoil and subsoil overlying natural geology of gravelly sand.					Length (m)		30
					Width (m)		2
					Avg. depth (m)		0.52
Context No.	Type	Fill Of	Width (m)	Depth (m)	Description	Finds	Date
1700	Layer		2	0.26	Ploughsoil. Dark brownish grey, clayey silt, soft		
1701	Layer		2	0.16	Subsoil. Mid greyish brown, clayey silt, soft		
1702	Layer		2		Natural. Light yellowish brown, gravelly sand, soft		
1703	Cut		1.2	0.24	Natural Feature. Tree throw. Mid brownish grey, silty sandy, soft		

1704	Cut		0.3	0.08	Natural Feature. Light yellowish grey, silty sand, soft		
1705	Cut		0.3	0.12	Natural Feature. Light brownish grey, sandy silt, soft		
<b>Trench 18</b> – not excavated							
<b>Trench 19</b> – not excavated							
<b>Trench 20</b>							
General description					Orientation		NW-SE
Trench devoid of archaeology. Consists of ploughsoil and subsoil overlying natural geology of gravel and silty sand.					Length (m)		30
					Width (m)		1.95
					Avg. depth (m)		0.55
Context No.	Type	Fill Of	Width (m)	Depth (m)	Description	Finds	Date
2000	Layer			0.25	Ploughsoil. Dark greyish brown sandy silt.		
2001	Layer			0.25	Subsoil. Light greyish brown sandy silt.		
2002	Layer				Natural. Gravel with frequent patches of orangey silty sand.		
<b>Trench 21</b>							
General description					Orientation		NE-SW
Trench devoid of archaeology. Consists of ploughsoil and subsoil overlying natural geology of silty sand.					Length (m)		30
					Width (m)		2
					Avg. depth (m)		1
Context No.	Type	Fill Of	Width (m)	Depth (m)	Description	Finds	Date
2100	Layer		2	0.2	Ploughsoil. Dark brownish grey, clayey silt, soft		
2101	Layer		2	0.25	Subsoil. Mid greyish brown, clayey silt, soft		
2102	Void						
2103	Layer		2		Natural. Light reddish brown, silty sand, soft		
<b>Trench 22</b>							
General description					Orientation		NW-SE
Trench devoid of archaeology. Consists of ploughsoil and subsoil overlying natural geology of clayey sand.					Length (m)		20
					Width (m)		2
					Avg. depth (m)		0.4
Context No.	Type	Fill Of	Width (m)	Depth (m)	Description	Finds	Date

2200	Layer		2	0.2	Ploughsoil. Dark brownish grey, clayey silt, soft		
2201	Layer		2		Subsoil. Mid greyish brown, clayey silt, soft		
2202	Layer		2		Natural. Light yellowish brown, clayey sand, firm		
<b>Trench 23</b>							
General description					Orientation		NE-SW
Trench devoid of archaeology. Consists of ploughsoil and subsoil overlying natural geology of clayey sand.					Length (m)		30
					Width (m)		2
					Avg. depth (m)		0.42
Context No.	Type	Fill Of	Width (m)	Depth (m)	Description	Finds	Date
2300	Layer		2	0.2	Ploughsoil. Dark brownish grey, clayey silt, soft		
2301	Layer		2	0.22	Subsoil. Mid greyish brown, clayey silt, soft		
2302	Layer		2		Natural. Light yellowish brown, clayey sand, firm		
<b>Trench 24</b>							
General description					Orientation		NW-SE
Trench revealed a ditch and two pits. Consists of ploughsoil and subsoil overlying natural geology of clayey sand.					Length (m)		30
					Width (m)		2
					Avg. depth (m)		0.52
Context No.	Type	Fill Of	Width (m)	Depth (m)	Description	Finds	Date
2400	Layer		2	0.3	Ploughsoil. Dark brownish grey, clayey silt, soft		
2401	Layer		2	0.22	Subsoil. Mid greyish brown, clayey silt, soft		
2402	Layer		2		Natural. Light yellowish brown, clayey sand, firm		
2403	Cut		1.6	0.62	Ditch		
2404	Fill	2403	1.6	0.62	Deliberate Backfill. Mid whiteish grey, sandy silt, compact.		
2405	Cut		0.39	0.08	Pit.		
2406	Fill	2405	0.39	0.08	Primary Fill. Dark brownish grey, mod compact, sandy silt		
2407	Cut		0.47	0.13	Pit.		
2408	Fill	2407	0.47	0.13	Primary Fill. Dark brownish grey, sandy silt, moderately compact		

2409	Fill	2403	0.27	0.6	Primary Fill. Mid reddish brown, silty clay, firm		
2410	Fill	2403	0.65	0.2	Secondary Fill. Mid brownish grey, silty sand, friable		
<b>Trench 25</b>							
General description					Orientation		NE-SW
Trench revealed one ditch. Consists of ploughsoil and subsoil overlaying natural geology of sandy clay.					Length (m)		30
					Width (m)		2
					Avg. depth (m)		0.46
Context No.	Type	Fill Of	Width (m)	Depth (m)	Description	Finds	Date
2500	Layer		2	0.26	Ploughsoil. Dark brownish grey, clayey silt, soft		
2501	Layer		2	0.18	Subsoil. Mid greyish brown, clayey silt, soft	Pot	900-1250AD
2502	Layer		2		Natural. Light yellowish brown, clayey sand with frequent gravel, firm		
2503	Cut		0.92	0.4	Ditch		
2504	Fill	2503	0.6	0.26	Secondary Fill. Light brown grey, silty sand, compact	Pot	Prehistoric
2505	Fill	2503	0.92	0.16	Secondary Fill. Dark grey brown, silty clay, friable		
<b>Trench 26</b>							
General description					Orientation		NW-SE
Trench revealed a ditch, four pits and an unexcavated feature. Consists of ploughsoil and subsoil overlying natural geology of silty sand.					Length (m)		30
					Width (m)		2
					Avg. depth (m)		0.4
Context No.	Type	Fill Of	Width (m)	Depth (m)	Description	Finds	Date
2600	Layer		2	0.28	Ploughsoil. Dark brownish grey, clayey silt, soft		
2601	Layer		2	0.18	Subsoil. Mid reddish brown, clayey silt, soft		
2602	Layer		2		Natural. Light yellowish brown, silty sand, soft		
2603	Cut		0.5	0.06	Pit. Possibly natural feature		
2604	Fill	2603	0.5	0.06	Secondary Fill. Dark brownish grey, clayey silt, soft		
2605	Cut		0.86	0.4	Ditch		
2606	Fill	2605	0.38	0.2	Primary Fill. Light greyish brown, silty sand, firm		

2607	Fill	2605	0.86	0.2	Secondary Fill. Mid brownish grey, sandy silt, soft		
2608	Cut		0.9	0.8	Pit. Likely modern		
2609	Fill	2608	0.22	0.9	Primary Fill. Mid greyish brown, clayey silt, soft		
2610	Cut		0.77	0.28	Pit		
2611	Fill	2610	0.77	0.28	Secondary Fill. Mid greyish brown, sandy silt, soft	Pot	MBA-EIA
2612	Unexcavated feature		0.3		Posthole. Mid greyish brown, sandy silt, soft		
2613	Void						
2614	Fill	2608	0.84	0.34	Deliberate Backfill. Light brownish yellow, mixed silty sands, soft		
2615	Cut		1.8	0.5	Pit		
2616	Fill	2615	1.8	0.34	Secondary Fill. Mid reddish brown, sandy silt, soft		
2617	Cut		3	0.3	Natural Feature. Irregular, likely tree throw. Mid greyish brown, sandy silt, soft		
2618	Fill	2615	0.8	0.2	Secondary Fill. Light brownish grey, sandy silt, compact.		

### Trench 27

General description					Orientation		NE-SW
Trench revealed one ditch, one posthole and two pits. Consists of ploughsoil and subsoil overlying natural geology of gravel and silty sand.					Length (m)		30
					Width (m)		1.95
					Avg. depth (m)		0.45
Context No.	Type	Fill Of	Width (m)	Depth (m)	Description	Finds	Date
2700	Layer			0.35	Ploughsoil. Dark greyish brown, silty clay, soft		
2701	Layer			0.25	Subsoil. Mid greyish brown, sandy silt, soft		
2702	Layer				Natural. Light Orange yellow, sand with gravel patches, soft		
2703	Cut		0.93	0.26	Pit		
2704	Fill	2703	0.93	0.26	Primary Fill. Mid greyish brown, sandy silt, soft	Pot, Fired clay, burnt flint	Beaker pottery and prehistoric flint
2705	Cut		0.5	0.07	Posthole		
2706	Fill	2705	0.5	0.07	Primary Fill. Mid greyish brown, sandy silt, soft		
2707	Cut		1.7	0.3	Ditch		

2708	Fill	2707	1.7	0.3	Primary Fill. Dark brownish grey, sandy silt, soft		
2709	Cut		1.5	0.25	Natural Feature. Soft, Dark greyish brown, sandy silt		
2710	Void						
2711	Cut		1.1	0.4	Pit		
2712	Fill	2711	0.4	1.1	Secondary Fill. Soft, mid greyish brown, silty sand		

### Trench 28

General description					Orientation		NW/SE and NE/SW
Trench devoid of archaeology. Consists of ploughsoil and subsoil overlying natural geology of gravel and silty sand.					Length (m)		30
					Width (m)		1.95
					Avg. depth (m)		0.5
Context No.	Type	Fill Of	Width (m)	Depth (m)	Description	Finds	Date
2800	Layer			0.25	Ploughsoil. Mid greyish brown sandy silt.		
2801	Layer			0.25	Subsoil. Light brown sandy silt.		
2802	Layer				Natural. Gravel and yellowish orange silty sand.		
2803	Cut		0.62	0.15	Natural Feature. Sub circular with rooted edges. Dark brown, silty sand, soft		

### Trench 29

General description					Orientation		NW-SE
Trench revealed one modern feature. Consists of ploughsoil overlying subsoil and and natural geology of clayey sand.					Length (m)		30
					Width (m)		2
					Avg. depth (m)		1
Context No.	Type	Fill Of	Width (m)	Depth (m)	Description	Finds	Date
2900	Layer		2	0.28	Ploughsoil. Dark brownish grey, clayey silt, soft		
2901	Layer		2	0.24	Subsoil. Mid greyish brown, clayey silt, soft		
2902	Layer		2	0.4	Natural. Light yellowish brown, clayey sand, firm.		
2903	Void						

### Trench 30

General description					Orientation		NE-SW
Trench devoid of archaeology. Consists of ploughsoil overlying subsoil and natural of clayey sand.					Length (m)		30
					Width (m)		2
					Avg. depth (m)		0.5
Context No.	Type	Fill Of	Width (m)	Depth (m)	Description	Finds	Date
3000	Layer		2	0.18	Ploughsoil. Dark brownish grey, clayey silt, soft		
3001	Layer		2	0.3	Subsoil. Mid greyish brown, clayey silt, soft		
3002	Layer		2		Natural. Mixed mid greyish brown and light yellowish brown, clayey sand, firm		
3003	Cut		0.18	0.06	Natural Feature. Fill consisted of a very thin lens of charcoal flecks on the surface and the rest a mid greyish brown, silty clay, soft.		
3004	Void						

**Trench 31**

General description					Orientation		NW-SE
Trench revealed one pit and a posthole. Consists of ploughsoil overlying subsoil and natural geology of clayey sand.					Length (m)		30
					Width (m)		2
					Avg. depth (m)		0.46
Context No.	Type	Fill Of	Width (m)	Depth (m)	Description	Finds	Date
3100	Layer		2	0.24	Ploughsoil. Dark brownish grey, clayey silt, soft		
3101	Layer		2	0.22	Subsoil. Mid greyish brown, clayey silt, soft		
3102	Layer		2		Natural. Light yellowish brown, clayey sand, firm		
3103	Cut		0.14	0.12	Posthole		
3104	Fill	3103	0.14	0.12	Primary Fill. Hard, mid greyish black, silty clay		
3105	Cut		0.96	0.14	Pit		
3106	Fill	3105	0.96	0.14	Primary Fill. Highly compact, light greyish brown, silty clay		
3107	Cut		0.65	0.03	Natural Feature. Mid reddish brown, silty sand, soft, frequent gravel		

**Trench 32**

General description					Orientation		NE-SW
---------------------	--	--	--	--	-------------	--	-------

Trench revealed one ditch. Consists of ploughsoil overlying subsoil and natural geology of clayey sand.					Length (m)	30	
					Width (m)	2	
					Avg. depth (m)	0.5	
Context No.	Type	Fill Of	Width (m)	Depth (m)	Description	Finds	Date
3200	Layer		2	0.3	Ploughsoil. Dark brownish grey, clayey silt, soft		
3201	Layer		2	0.2	Subsoil. Mid greyish brown, clayey silt, soft		
3202	Layer		2		Natural. Light yellowish brown, clayey sand, firm		
3203	Cut		1.3	0.14	Ditch		
3204	Fill	3203	1.3	0.14	Primary Fill		

<b>Trench 33</b>							
General description					Orientation		NW-SE
Trench revealed two ditches. Consists of ploughsoil overlying subsoil and natural geology of clayey sand.					Length (m)		30
					Width (m)		2
					Avg. depth (m)		0.46
Context No.	Type	Fill Of	Width (m)	Depth (m)	Description	Finds	Date
3300	Layer		2	0.26	Ploughsoil. Dark brownish grey, clayey silt, soft		
3301	Layer		2	0.2	Subsoil. Mid greyish brown, clayey silt, soft		
3302	Layer		2		Natural. Light yellowish brown, clayey sand, firm		
3303	Cut		0.78	0.07	Ditch.		
3304	Fill	3303	0.78	0.07	Primary Fill. Mod compact, dark orangish brown, silty sand		
3305	Cut		1.1	0.14	Ditch.		
3306	Fill	3305	1.1	0.14	Primary Fill. Mod compact, dark orangish brown, silty sand.	Pot	Prehistoric

<b>Trench 34</b>							
General description					Orientation		NE-SW
Trench devoid of archaeology. Consists of ploughsoil and subsoil overlying natural geology of sandy clay.					Length (m)		30
					Width (m)		2
					Avg. depth (m)		0.5
Context No.	Type	Fill Of	Width (m)	Depth (m)	Description	Finds	Date
3400	Layer		2	0.26	Ploughsoil. Dark brownish grey, clayey silt, soft		



3401	Layer		2	0.24	Subsoil. Mid greyish brown, clayey silt, soft		
3402	Layer		2		Natural. Light reddish brown, sandy clay, firm		
3403	Cut		1.95	0.15	Natural Feature. Mid-light orangey yellow brown, friable, silty sand.		

**Trench 35**

General description					Orientation		NW-SE
Trench revealed two ditches and a pit. Consists of ploughsoil and subsoil overlying natural geology of gravely sand.					Length (m)		30
					Width (m)		2
					Avg. depth (m)		0.8
Context No.	Type	Fill Of	Width (m)	Depth (m)	Description	Finds	Date
3500	Layer			0.36	Ploughsoil. Dark greyish brown, silty clay, soft		
3501	Layer			0.35	Subsoil. Mid greyish brown, silty clay, soft		
3502	Layer				Natural. Light Orange yellow, gravely sand, loose.		
3503	Cut		3.3	0.75	Ditch		
3504	Fill		3.3	0.75	Primary Fill. Very firm, light yellowish brown, silty clay		
3505	Cut		1.3	0.2	Pit		
3506	Fill	3505	1.3	0.2	Primary Fill. Firm, light whitish orange, sandy silt		
3507	Cut		1.25	0.55	Ditch		
3508	Fill	3507	1.25	0.55	Primary Fill. Firm, light yellowish brown, silty clay		

**Trench 36**

General description					Orientation		NE-SW
Trench revealed one pit. Consists of ploughsoil and subsoil overlying natural geology of gravel and silty sand.					Length (m)		30
					Width (m)		1.95
					Avg. depth (m)		0.6
Context No.	Type	Fill Of	Width (m)	Depth (m)	Description	Finds	Date
3600	Layer			0.3	Ploughsoil. Mid greyish brown sandy silt.		
3601	Layer			0.3	Subsoil. Light greyish brown sandy silt.		
3602	Layer				Natural. Gravel and orangey silty sand.		
3603	Cut		0.73	0.17	Posthole.		

3604	Fill	3603	0.73	0.17	Primary Fill. Loose, dark greyish brown, silty gravel.		
3605	Cut		0.75	0.25	Natural Feature		
3606	Cut		1.2	0.24	Tree Throw		
3607	Unexcavated feature		0.65		Natural Feature. Mid greyish brown silty sand		
3608	Cut		0.68	0.3	Pit		
3609	Fill	3608	0.68	0.3	Secondary Fill. Mid brown grey, silty sand, loose		
3610	Fill	3606	1.2	0.24	Secondary Fill. Mid grey brown, silty sand, loose		
<b>Trench 37</b>							
General description					Orientation		NW-SE
Trench revealed three ditches, and three pits. Consists of ploughsoil and subsoil overlying natural geology of orange sand and gravel.					Length (m)		30
					Width (m)		1.95
					Avg. depth (m)		0.4
Context No.	Type	Fill Of	Width (m)	Depth (m)	Description	Finds	Date
3700	Layer		0.24		Ploughsoil. Dark greyish brown silty sand		
3701	Layer		0.16		Subsoil. Mid brownish grey silty sand		
3702	Layer				Natural. Brownish orange gravelly sand		
3703	Cut		1.25	0.46	Ditch.		
3704	Fill	3703	1.25	0.24	Primary Fill. Compact, light grey, silty sand		
3705	Fill	3703	1.25	0.22	Secondary Fill. Mod compact, dark brown, silty sand.		
3706	Cut		0.95	0.36	Ditch.		
3707	Fill	3706	0.95	0.23	Primary Fill. Light grey, compact, silty sand.		
3708	Fill	3706	0.95	0.12	Secondary Fill. Dark brown, mod compact, sandy silt.		
3709	Cut		1.13	0.17	Pit.		
3710	Fill	3709	1.13	0.17	Primary Fill. Light brownish grey, sandy silt, moderately compact		
3711	Unexcavated feature		0.6		Pit. Sub circular pit found at bulk. Dark greyish brown, sandy silt, soft.		
3712	Cut		1.34		Ditch		

3713	Fill	3712	0.96	0.3	Primary Fill. Dark greyish brown, sandy silt, soft		
3714	Fill	3712	1.12	0.5	Secondary Fill. Light reddish brown, silty sand, soft		
3715	Cut		0.2	0.12	Posthole		
3716	Fill	3715	0.2	0.12	Secondary Fill. Dark brownish grey, sandy silt, loose		
3717	Cut		1	0.3	Pit		
3718	Fill	3717	1	0.3	Secondary Fill. Soft, mid reddish brown, sandy silt		
3719	Unexcavated feature		1.15		Pit. Elongated in plan, partially exposed in the trench. Containing a light brown sandy silt fill.		

### Trench 38

General description					Orientation		NW-SE
Trench devoid of archaeology. Consists of ploughsoil and subsoil overlying natural geology of sandy gravel.					Length (m)		30
					Width (m)		2
					Avg. depth (m)		0.42
Context No.	Type	Fill Of	Width (m)	Depth (m)	Description	Finds	Date
3800	Layer		2	0.25	Ploughsoil. Dark brownish grey, clayey silt, soft		
3801	Layer		2	0.12	Subsoil. Mid greyish brown, clayey silt, soft		
3802	Layer		2		Natural. Mid reddish brown, sandy gravel, soft		

### Trench 39

General description					Orientation		NW-SE
Trench devoid of archaeology. Consists of ploughsoil and subsoil overlying natural geology of silty sand, clay and gravel.					Length (m)		30
					Width (m)		1.95
					Avg. depth (m)		0.44
Context No.	Type	Fill Of	Width (m)	Depth (m)	Description	Finds	Date
3900	Layer		2	0.2	Ploughsoil. Dark brownish grey, clayey silt, friable		
3901	Layer		2	0.24	Subsoil. Mid greyish brown, clayey silt, soft		
3902	Layer		2	0.3	Natural. Light reddish brown, clayey sand with frequent gravel, firm.		
3903	Void						

<b>Trench 40</b>							
General description					Orientation		NW-SE
Trench devoid of archaeology. Consists of ploughsoil and subsoil overlying natural geology of gravel, sand and clayey sand.					Length (m)		30
					Width (m)		1.95
					Avg. depth (m)		0.7
Context No.	Type	Fill Of	Width (m)	Depth (m)	Description	Finds	Date
4000	Layer			0.3	Ploughsoil. Mid brownish grey sandy silt.		
4001	Layer			0.35	Subsoil. Light brown silty sand.		
4002	Layer				Natural. Varies across the trench. Gravel, fine orangey sand and compact mid brown clayey sand.		
<b>Trench 41</b>							
General description					Orientation		NE-SW
Trench devoid of archaeology. Consists of ploughsoil and subsoil and overlying natural geology of brown clay, sand and gravel.					Length (m)		30
					Width (m)		1.95
					Avg. depth (m)		0.61
Context No.	Type	Fill Of	Width (m)	Depth (m)	Description	Finds	Date
4100	Layer			0.35	Ploughsoil. Mid brownish grey sandy silt.		
4101	Layer			0.26	Subsoil. Mid brown sandy silt.		
4102	Layer			0.35	Natural. Compact mix of brown sandy clay, fine sand and occasionally gravel.		
4103	Void						
<b>Trench 42</b>							
General description					Orientation		NW-SE
Trench devoid of archaeology. Consists of ploughsoil and subsoil overlying natural geology of sand and gravel.					Length (m)		30
					Width (m)		0.95
					Avg. depth (m)		0.65
Context No.	Type	Fill Of	Width (m)	Depth (m)	Description	Finds	Date
4200	Layer			0.25	Ploughsoil. Mid greyish brown sandy silt.		
4201	Layer			0.25	Subsoil. Mid greyish brown sandy silt.		
4202	Layer			0.15	Natural. Compact mix of brown clay and gravel.		
4203	Void						

<b>Trench 43</b>							
General description					Orientation		NE-SW
Trench revealed on posthole. Consists of ploughsoil and subsoil overlying natural geology of orangey silty sand and gravel.					Length (m)		30
					Width (m)		1.95
					Avg. depth (m)		0.55
Context No.	Type	Fill Of	Width (m)	Depth (m)	Description	Finds	Date
4300	Layer			0.25	Ploughsoil. Dark brownish grey sandy silt.		
4301	Layer			0.25	Subsoil. Light greyish brown sandy silt.		
4302	Layer				Natural. Light orangey silty sand with frequent gravel and occasionally patches of light grey sandy silt.		
4303	Cut		0.32	0.14	Posthole.		
4304	Fill	4303	0.32	0.14	Primary Fill. Light brownish grey, mod compact, sandy silt		
<b>Trench 44</b>							
General description					Orientation		E-W
Trench devoid of archaeology. Consists of ploughsoil and subsoil overlying natural geology of sandy clay with patches of gravel.					Length (m)		30
					Width (m)		1.95
					Avg. depth (m)		0.55
Context No.	Type	Fill Of	Width (m)	Depth (m)	Description	Finds	Date
4400	Layer			0.25	Ploughsoil. Mid greyish brown sandy silt.		
4401	Layer			0.3	Subsoil. Mid brown sandy silt.		
4402	Layer			0.3	Natural. Mix of brownish clay, sand and gravel.		
4403	Void						
<b>Trench 45 – not excavated</b>							
<b>Trench 46 – not excavated</b>							
<b>Trench 47</b>							
General description					Orientation		NW-SE
					Length (m)		30
					Width (m)		0.95

Trench devoid of archaeology. Consists of ploughsoil and subsoil overlying natural geology of gravel and sand.					Avg. depth (m)	0.6	
Context No.	Type	Fill Of	Width (m)	Depth (m)	Description	Finds	Date
4700	Layer			0.3	Ploughsoil. Mid greyish brown sandy silt.		
4701	Layer			0.2	Subsoil. Light greyish brown sandy silt.		
4702	Layer			0.2	Natural. Compact light brown sandy clay with patches of gravel.		
4703	Void						

## Appendix B Finds Reports

### B.1 Prehistoric Pottery

By Alex Davies

#### Introduction

B.1.1 The evaluation recovered 26 sherds (122g) of prehistoric pottery from five contexts across five trenches. The assemblage was diverse, representing at least three periods. The assemblage is summarised in Table 1.

#### Description

B.1.2 Context 1404 produced probable early Neolithic pottery. These were undecorated body sherds, but the fabric was typically early Neolithic containing poorly sorted, sparse flint temper of variable grade, but up to 5mm in size. The sherds are distinct from the flint tempered later Bronze Age and Iron Age recovered from context 2611 and elsewhere on the scheme. It is likely that these belong to one or more early Neolithic Plain Bowls.

B.1.3 Context 2704 produced sherds from two or three Beakers. One was a typically fine Beaker with comb decoration and tempered with fine flint. Another was a grog tempered coarser 'domestic' Beaker with fingernail decoration. There was another undecorated coarse grog tempered sherd that might belong to the second vessel or to a third.

B.1.4 Context 2611 produced sherds from a vessel datable only to the middle Bronze Age to early Iron Age. The vessel consisted of flint tempered (well sorted) body sherds. There was a weak shoulder, although this is not chronologically diagnostic.

Context	Count	Weight (g)	Fabric	Spot-date	Comment
1404	3	35	Flint, coarse, poorly sorted	E Neo	Inc 2 sherds (24g) from enviro sample 1
2504	7	2	Flint	Undatable	Crumbs. Probably prehistoric
2611	8	37	Flint, med, well sorted	MBA-EIA	Weak shoulder
2704	6	45	Grog; Flint, fine, well sorted	Beaker	At least two vessels - a fine comb decorated beaker (flint tempered), and a coarser 'domestic' Beaker with fingernail decoration (grog-tempered). Inc 3 sherds (16g) from enviro sample 2
3306	2	3	Flint, sand	Prehistoric	Highly abraded
<b>Total</b>	<b>26</b>	<b>122</b>			

Table 1: Prehistoric pottery

## B.2 Medieval Pottery

By John Cotter

### Introduction and methodology

- B.2.1 A single sherd of pottery weighing 18g was recovered. This has not been separately catalogued but is fully described below. Medieval fabric codes referred to are those of the Museum of London (MOLA 2014).

### Description

- B.2.2 **Context (2501) Spot-date: c 900-1250:** 1 sherd (18g). Fresh body sherd from a jar or spouted pitcher in Pingsdorf-type red-painted ware (Fabric REDP, c 900-1250). Very hard, fine sandy, near-stoneware fabric. Off-cream colour with light grey surfaces. On the external surface are two, almost parallel, vertical stripes of dark brown paint - the surviving traces of a decorative scheme. Painted decoration on this ware is usually a red-brown colour, but a reduced firing atmosphere has caused this to appear darker than usual. The vessel is clearly wheel-thrown and evidently quite large - with a maximum diameter of c 220mm at the girth. The wall thickness is 3.5-4mm and the sherd has a maximum length of 68mm.
- B.2.3 The fabric code REDP is used in London to cover a limited range of Rhenish Red painted wares, traditionally known as Pingsdorf-type ware, after the town of that name near Cologne, in north-west Germany. Vessels associated with the drinking and serving of beverages, including beakers and spouted pitchers with frilled bases, are the commonest forms found in London, but some small jar/cooking pots are also known (Vince and Jenner 1991, fig. 2.107). Even in London the ware is not particularly common. While it has a quite a long date range (c 900-1250) it is typically found in London deposits of the 11th-12th century (ibid., 102). It is rarer from Essex. The presence of the isolated sherd here, from near Orsett Heath, can probably be explained by its proximity to the Thames estuary.



## B.3 Flint

By Lawrence Billington

### Introduction

- B.3.1 A very small assemblage of three struck flints and 49g (10 fragments) of unworked burnt flint was recovered during the evaluation. A basic quantification of the assemblage is provided in Table 2.

Context	Cut	Sample	Feature type	Flake	Burnt unworked flint count	Burnt unworked flint weight (g.)
604	603		Ditch	1		
1404	1403	1	Pit		10	48.6g
2704	2703	2	Pit	2		

Table 2. Quantification of the worked and burnt flint

### Results

- B.3.2 The fill of ditch 603, Trench 6, produced a single narrow decortication flake, and has the distinctive green-grey cortex and underlying orange band of flint derived from the bullhead beds, found at the base of certain Tertiary deposits in southeast and eastern England where they overlay the flint-bearing chalk (Shepherd 1972, 114).
- B.3.3 Pit 1403, Trench 14, produced a small quantity of burnt, unworked, flint. This material was heavily calcined and highly fragmented, with ten fragments weighting 49g (mean clast weight of 4.9g).
- B.3.4 Two small, partly cortical flakes, in fresh condition, were recovered from pit 2703, Trench 27. Both are simple hard hammer struck removals and although they did not refit they may derive from the same nodule of raw material.

### Discussion

- B.3.5 None of the worked flints can be regarded as chronologically diagnostic, but they are consistent with a broad Neolithic or early Bronze Age date. It seems likely that the single flint from ditch 603 is residual, whilst the pair of flakes from pit 1403 may be broadly contemporary with the feature from which they derive. The small assemblage of burnt flint from pit 2703 is also likely to be of prehistoric date.

## B.4 Fired Clay

By Cynthia Poole

- B.4.1 Two fragments of fired clay were recovered from pit 2703 (fill 2704). Neither have any original shaped surfaces surviving. One (3g) recovered by hand excavation is a small rounded heavily abraded piece 18mm long made in a coarse sandy fabric fired red grading to yellowish brown at one end. The second fragment (9g) from a sieved sample 2 is irregular and amorphous and moderately abraded. It is made in fine sandy-silty clay with fine pores possibly from fine roots grown through it. It is fired grey apart from a reddened tip on one side. No firm conclusions can be drawn from these pieces, suffice to say that they are consistent with debris dislodged from domestic ovens or hearths during raking out of such structures.

## B.5 Worked Stone

By Ruth Shaffrey

### Introduction

- B.5.1 A single piece of stone weighing 420g and measuring 43mm thick was recovered from context 403. This was recorded with the aid of x10 magnification hand lens. The stone retains no original edges, but one of two flat, parallel faces has been worn smooth through use. Both faces also have a fine groove across them, which could be from sharpening. The stone is a medium grained micaceous sandstone, slightly reddened on one face through exposure to heat. The stone could have been used as a quern, but has certainly been used as a sharpening stone. The sandstone is not distinctive enough for a provenance to be established, but it could be from the Thanet Formation.

### C.1 Environmental Samples

By Richard Palmer

#### Introduction

- C.1.1 Two bulk samples were taken as part of the evaluation, primarily for the retrieval and assessment of charred plant remains (CPR) and the recovery of bones and artefacts.

#### Method

- C.1.2 The samples were processed in their entirety at Oxford Archaeology using a modified Siraf-type water flotation machine. The flots were collected in a 250µm mesh and residues in a 500µm mesh and dried. The residue fractions were sorted by eye and with the aid of a magnet while the flot material was sorted using a low power (x10) binocular microscope to extract cereal grains and chaff, smaller seeds and other quantifiable remains.

#### Results

- C.1.3 Summary sample and flot abundance data is presented in Table 3.
- C.1.4 **Trench 14.** Sample 1 from fill 1404 of early Neolithic pit 1403 produced a large flot. Recovered charcoal includes ring porous specimens and the outer surface of many fragments is dirty with sand encrustation. Recovered CPR is in mixed condition with grain potentially being wheat (cf *Triticum* sp.) and chaff being a mix of rachis and glume fragments. The weed assemblage includes dock seeds (*Rumex* sp.) and charred goosefoot seeds (*Chenopodium* sp.) both in small quantities. Pottery and burnt flint were recovered from the residue.
- C.1.5 **Trench 27.** Sample 2 from fill 2704 of Beaker pit 2703 produced a flot containing only charcoal and clinker-like material. Pottery, burnt flint and fired clay were recovered from the residue.

#### Discussion

- C.1.6 The potential for recovery of charred material on site is variable in both quantity and preservation. The early Neolithic date for sample 1 places a high level of significance on the material recovered despite the small quantities.

#### Recommendations for retention/dispersal

- C.1.7 The flots warrant retention until the completion of the project. The possible early Neolithic sample should be retained for further analysis and scientific dating as part of any further work.

Sample no.	Context no.	Trench	Feature/Depo sit	Date	Sample vol. (L)	Flot vol. (ml)	Charcoal >2mm	Grain	Chaff	Weeds	Molluscs	Other	Notes
1	1404	14	1403	E Neo	12	75	+++	+	+	++			10YR 5/6 loamy sand
2	2704	27	2703	Beaker	20	25	+++						7.5YR 5/8 sand

Key: +=present (up to 5 items), ++=frequent (5-25), +++=common (25-100), ++++=abundant (100+)

Table 3. Assessment of environmental samples

## Appendix D      References

---

- BGS, 2020 *Geology of Britain Viewer*. Retrieved from <http://mapapps.bgs.ac.uk/geologyofbritain/home.html>
- CIfA, 2014a *Standard and Guidance for Archaeological Evaluation*, Chartered Institute for Archaeologists. Retrieved from <http://archaeologists.net/sites/default/files/node-files/IfASG-Evaluation.pdf>
- CIfA, 2014b *Standard and Guidance for the Creation, Compilation, Transfer and Deposition of Archaeological Archives*, Chartered Institute for Archaeologists
- Hedges, J D and Buckley, D G, 1978 Excavations at a Neolithic causewayed enclosure, Orsett, Essex, 1975. *Proceedings of the Prehistoric Society* **44**, 219–308
- Highways England, 2018 *Lower Thames Crossing: A Scheme Wide Specification for Archaeological Trial Trenching: unpublished document HE540039-CJV-GEN-GEN-SPE-HER-00001draft, Revision 1.05*
- Historic England, 2015 *Management of Research Projects in the Historic Environment: The MoRPHE Project Managers' Guide*. Swindon: Centre for Archaeology Guidelines
- Medlycott, M, 2011 *Research and archaeology revisited: a revised framework for the East of England*, East Anglian Archaeology, Occasional Papers **24**, Chelmsford
- MOLA, 2014 London medieval and post-medieval pottery codes, Museum of London Archaeology, <http://www.mola.org.uk/medieval-and-post-medieval-pottery-codes> (Accessed 11 Jan 2019)
- Oxford Archaeology, 2019a Lower Thames Crossing Scheme-wide Written Scheme of Investigation for Trial Trenching south of the River Thames, unpublished document
- Oxford Archaeology, 2019b Lower Thames Crossing Scheme-wide Written Scheme of Investigation for Trial Trenching north of the River Thames, unpublished document
- Oxford Archaeology, 2019c Lower Thames Crossing Detailed Written Scheme of Investigation for Trial Trenching of Land Parcel 2, unpublished document HE540039-BAL-GEN-GEN-REP-HER-00004, Oxford Archaeology
- OCA, 2020a Lower Thames Crossing: Evaluation report for Archaeological Trial Trenching of Land Parcel 3, Hornsby Lane, Orsett Heath, Essex, unpublished document HE540039-CJV-GEN-GEN-REP-GEO-00022, Issued March 2020, Oxford Cotswold Archaeology
- OCA, 2020b Lower Thames Crossing: Evaluation report for Archaeological Trial Trenching of Land Parcel 4, Old House, Chadwell St Mary, Essex,

unpublished document HE540039-CJV-GEN-GEN-REP-GEO-00023, Issued March 2020, Oxford Cotswold Archaeology

OCA, 2020c Lower Thames Crossing: Evaluation report for Archaeological Trial Trenching of Land Parcel 22, Whitfield South Scheduled Monument Cropmark Complex, South of Stifford Clays Road, Baker Street, Essex, unpublished document HE540039-CJV-GEN-GEN-REP-HER-00026, Issued December 2020, Oxford Cotswold Archaeology

Place Services, 2019 *Lower Thames Crossing Aerial Investigation and Mapping Report*, Essex County Council

Priddy, D and Buckley, D G, 1987 An assessment of excavated enclosures in Essex, together with a selection of cropmark sites, in D. G. Buckley, J. D. Hedges, and D. Priddy, *Excavations at Woodham Walter and an assessment of Essex enclosures*, East Anglian Archaeology **33**, Chelmsford

Shepherd, W, 1972 *Flint: Its origin, properties and uses*, London

Vince, A G and Jenner, A, 1991 The Saxon and early medieval pottery of London, in A. G. Vince (ed.), *Aspects of Saxon and Norman London 2: Finds and Environmental Evidence*, LAMAS Special Paper, **12**, 19-119.

## Appendix E      Abbreviations and Glossary

---

**ADS** Archaeology Data Service. Digital archaeological archive

**CDM** Construction Design Manual. Health and safety guidance for the construction industry

**CPD** Continuing Professional Development

**CIfA** Chartered Institute for Archaeologists

**DBA** Desk Based Assessment. Detailed assessment of archaeology and other aspects of the historic environment

**DCO** Development Consent Order

**EIA** Environmental Impact Assessment. Detailed study of environmental impacts as directed under the The Town and Country Planning (Environmental Impact Assessment) Regulations 2017 following on from EU Directive EIA Directive (85/337/EEC)

**ES** Environmental Statement. The principal environmental report detailing environmental impacts within an EIA

**GPS** Global Positioning System

**HER** Historic Environment Record

**LTC** Lower Thames Crossing

**MCIfA** Member of the Chartered Institute for Archaeologists

**MoRPHE** Management of Research Projects in the Historic Environment

**NMP** National Mapping Programme. A study of aerial photographs and digitisation of resulting data into GIS. Originally funded by Historic England

**OASIS** Online Access to the Index of archaeological investigations.  
The OASIS project brings together a number of strategic partners: the Archaeology Data Service, Historic England, Historic Environment Scotland, and the Royal Commission on the Ancient and Historical Monuments of Wales under the umbrella of the University of York

**OCN** Old County Number. Historic England's reference for material that is not readily-available online and may represent historic archaeological work that consists of paper archives or has yet to be formally reported on

**PINS** Planning Inspectorate

**RAMS** Risk Assessment Method Statement

**SMC** Scheduled monument consent

**TDR** Trusted Digital Repository

**UKIC** United Kingdom Institute for Conservation

**WSI** Written Project of Investigation. A detailed method statement for archaeological work

**WSL** – Western Southern Link  
The Western Southern Link (WSL) is an alternative for Short List Routes 2, 3 and 4 to the south of the River Thames.



## Appendix F Site Summary

---

<b>Site name:</b>	Lower Thames Crossing Land Parcel 2, Land North of Orsett Heath, Essex
<b>Site code:</b>	LTC2OH20
<b>Grid Reference</b>	NGR 564047 180101
<b>Type:</b>	Evaluation
<b>Date and duration:</b>	7th-16th October 2020
<b>Area of Site</b>	7.8 ha.

### Location of archive:

The archive from LTC2OH0 (Land Parcel 2) will form part of the overall trial trenching scheme archive. This will be deposited in a repository consistent with the standards required by the Museums and Galleries Commission following completion of the archaeological phase of this project. This may either be with the local receiving museum in Thurrock or, if no such repositories are available, with a repository for the whole project designated by LTC. LTC retain the overall responsibility for the successful deposition of the project archive.

Currently, the archive is held at Oxford Archaeology's head office, Janus House, Osney Mead, Oxford, Oxfordshire, OX2 0ES. Oxford Archaeology will store the archive for LTC for a maximum period of 2 years following the completion of the project. If the storage of the archive at OA's office extends past this period, an extension to the storage period and final deposition timetable will be reviewed by OA and LTC and agreed with the major stakeholders.

### Summary of Results:

Oxford Cotswold Archaeology was commissioned by Balfour Beatty to undertake a trial trench evaluation of Land Parcel 2, covered by WSI B of the Lower Thames Crossing Pre-Enabling Works. This land parcel is located c 30m north of the hamlet of Orsett Heath within the county of Essex and Thurrock unitary authority (NGR 564047 180101). A total of 41 trenches were excavated and recorded between 7th and 16th October 2020.

One early Neolithic pit was found in Trench 14 in the western part of the site, and one late Neolithic/early Bronze Age pit containing Beaker finds in the eastern half in Trench 27. These add to a pattern of dispersed early prehistoric activity on the gravel terrace identified from previous discoveries on the gravels in this area.

One pit containing later prehistoric (middle Bronze Age to early Iron Age) pottery was found in Trench 26, and two pits containing sherds only datable as prehistoric are also likely to be of later prehistoric date. Undated pits and ditches, including one curvilinear example, were scattered across the site, and many of these are also likely to be of prehistoric date, given the absence of later features or finds from the site.

No evidence of Roman or Anglo-Saxon activity was found, and only a single sherd of medieval pottery, although this was a rare continental import and thus of intrinsic interest.

Post-medieval finds were sparse. One NNW-SSE ditch in Trench 27 may well correspond to a boundary shown on the Tithe map of c 1840, although no continuation of this boundary was seen in Trench 41, which also crossed its line. It is likely that some of the undated ditches, particularly those on NNW-SSE or ENE-WSW alignments, may well be field boundaries of post-medieval date.

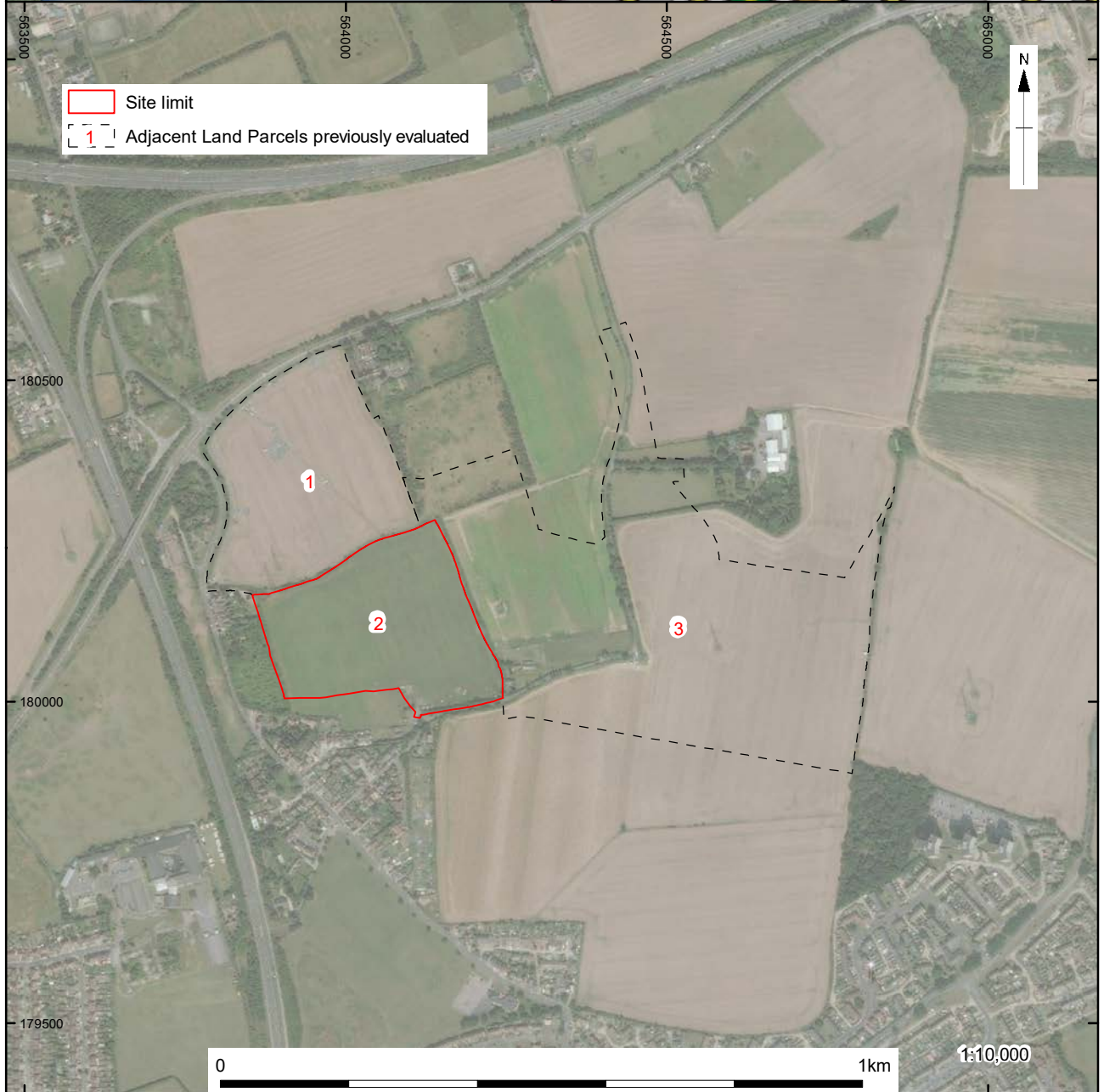
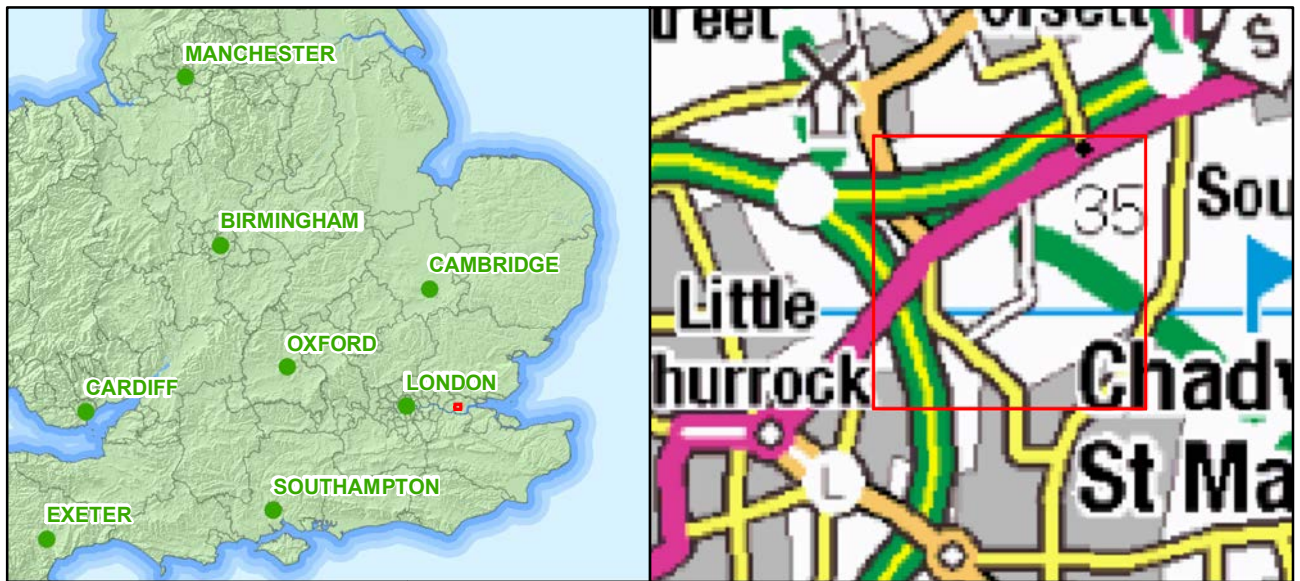

Contains OS data © Crown Copyright and database right 2020  
 Source: Esri, DigitalGlobe, GeoEye, Earthstar Geographics, CNES/Airbus DS, USDA,

Figure 1: Site location

\\10.0.10.86\Projects\MLTCEV\_Lower\_Thames\_Crossing\010Geomatics\03 GIS Projects - LTC20H20\Figures\LTC20H20\_Fig 1.mxd\caroline.sourday\*11/12/2020

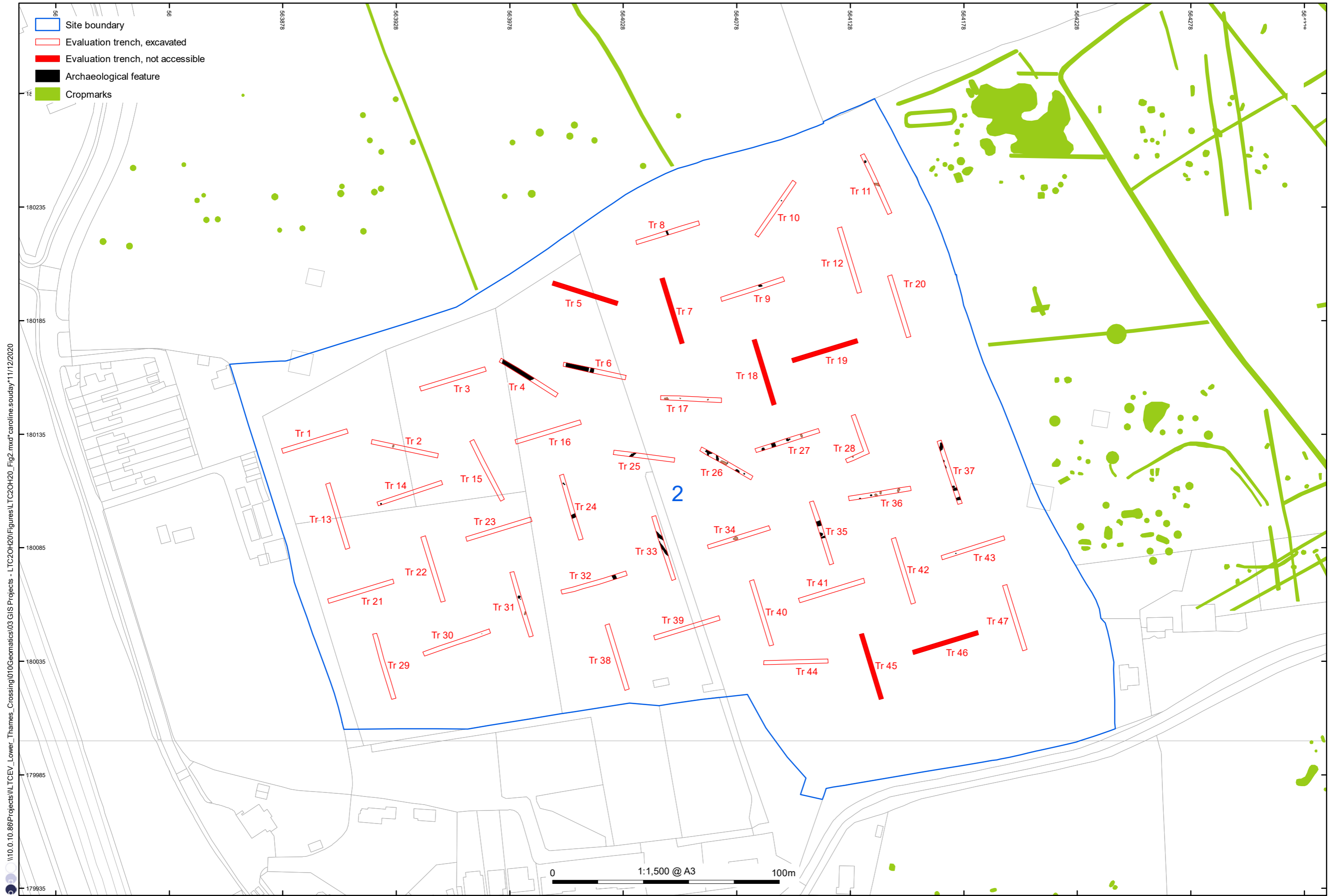

\\10.0.10.86\Projects\IL TCEV\_Lower\_Thames\_Crossing\010\geomatics\03 GIS Projects - LTC2OH20\Figures\LTC2OH20\_Fig2.mxd\*caroline.souday\*11/12/2020

Contains Ordnance Survey data © Crown copyright and database right 2020, provided by client

Figure 2: Plan of trench layouts and archaeological features

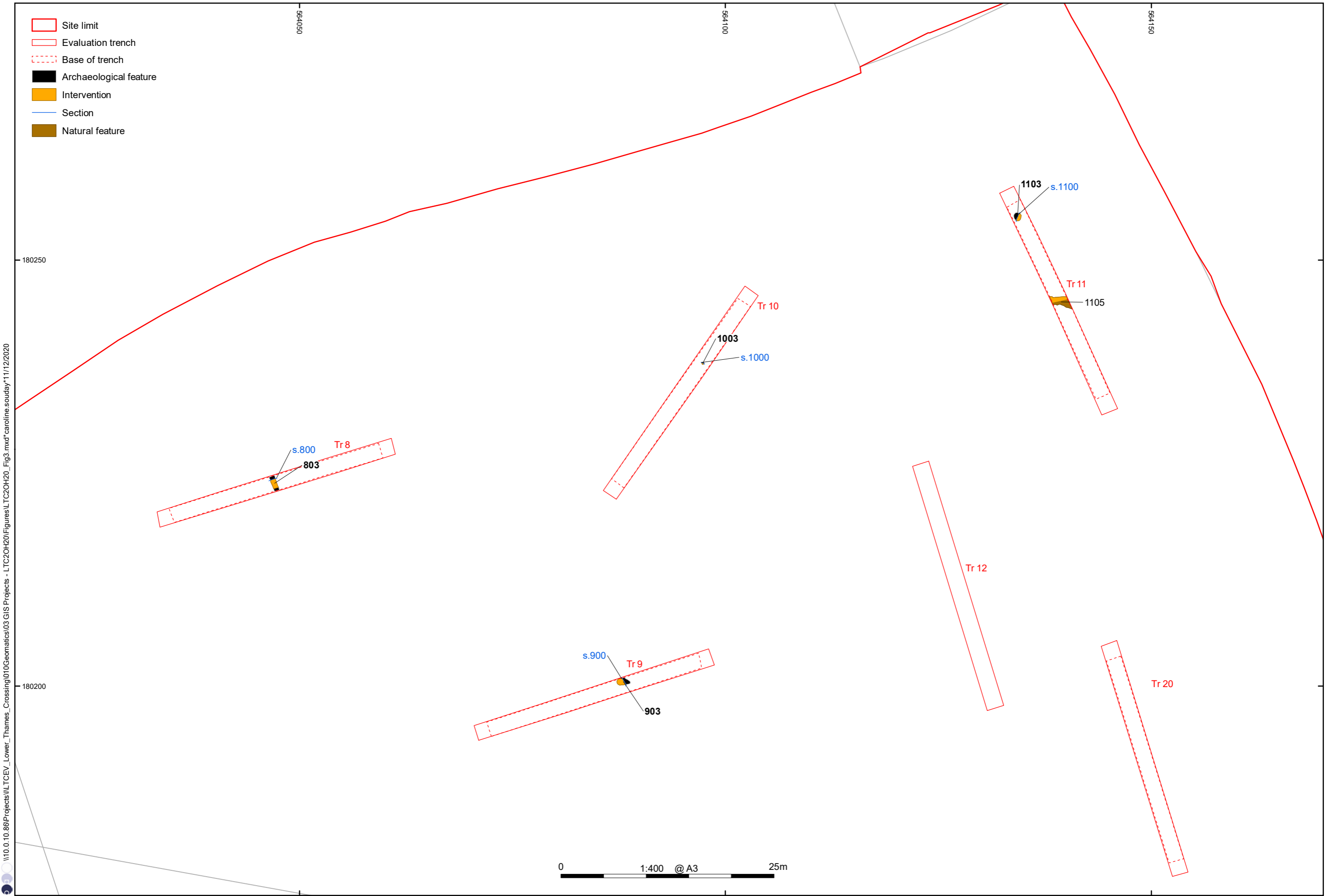

\\10.0.10.86\Projects\Lower\_Thames\_Crossing\010\geomatics\03 GIS Projects - LTC2OH20\Figures\Trenches\Fig3.mxd caroline.souday\*11/12/2020

Contains Ordnance Survey data © Crown copyright and database right 2020, provided by client

Figure 3: North-east of Land Parcel 2: Trenches 8-12 and 20

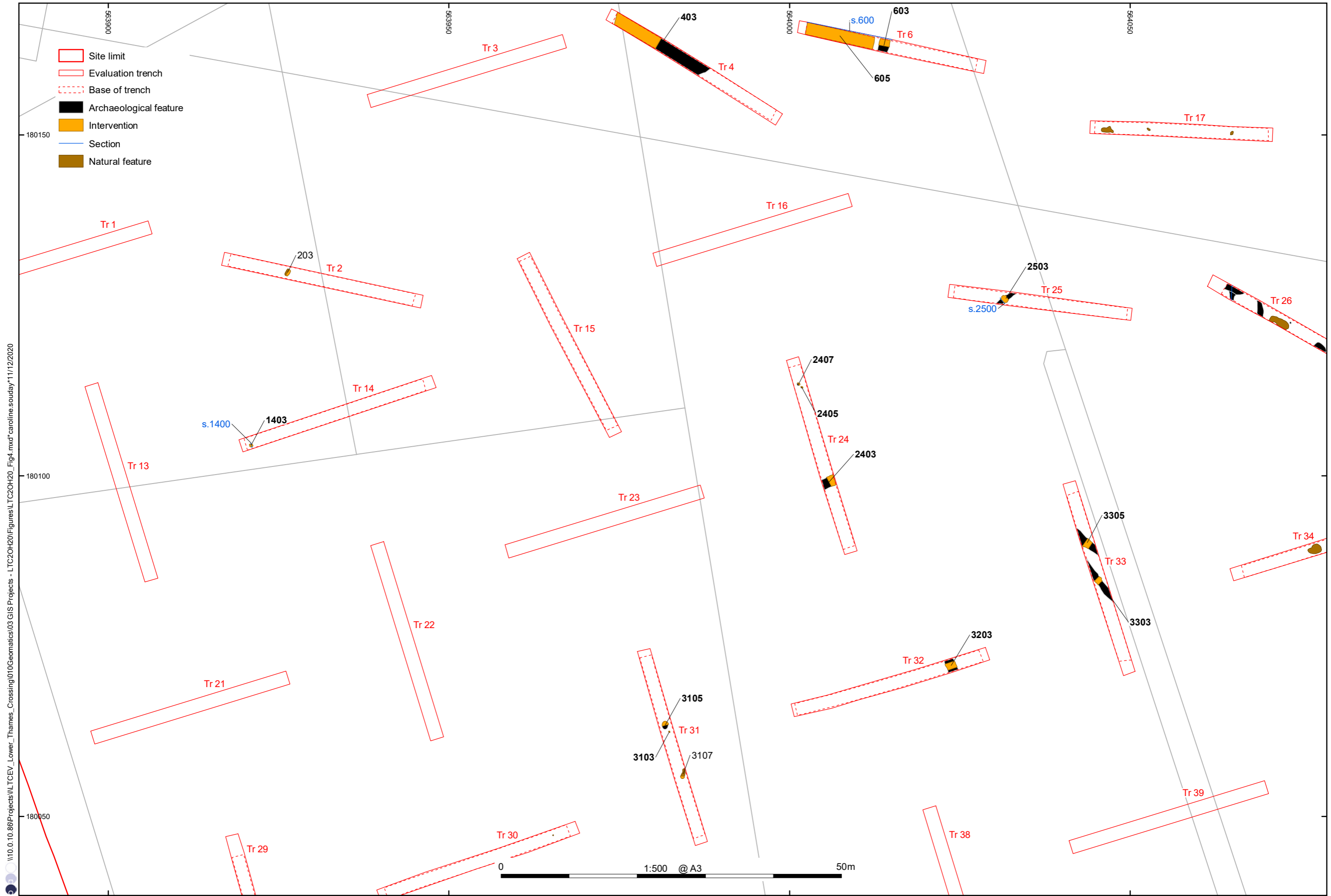

\\10.0.10.86\Projects\Lower\_Thames\_Crossing\01\GIS\Projects - LTC20H20\Figures\LTC20H20\_Fig4.mxd\*caroline.souday\*11/12/2020

Contains Ordnance Survey data © Crown copyright and database right 2020, provided by client

Figure 4: West side of Land Parcel 2: Trenches 1-4, 6, 13-17, 21-25 and 30-33

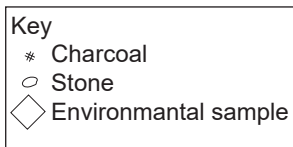
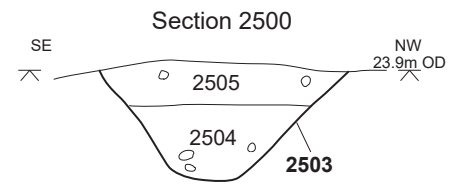
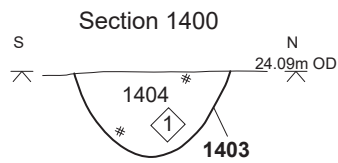
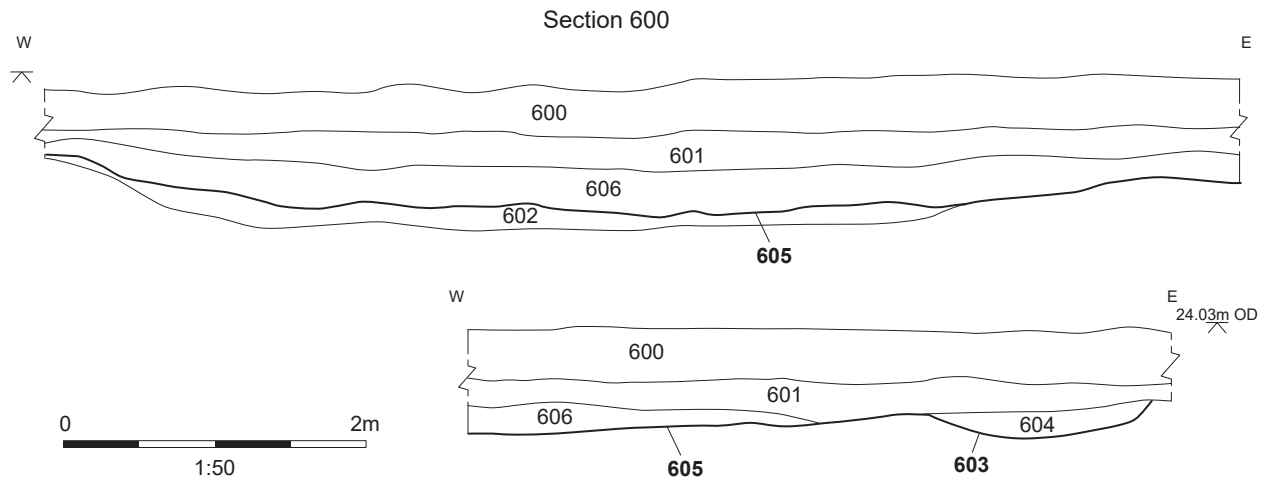
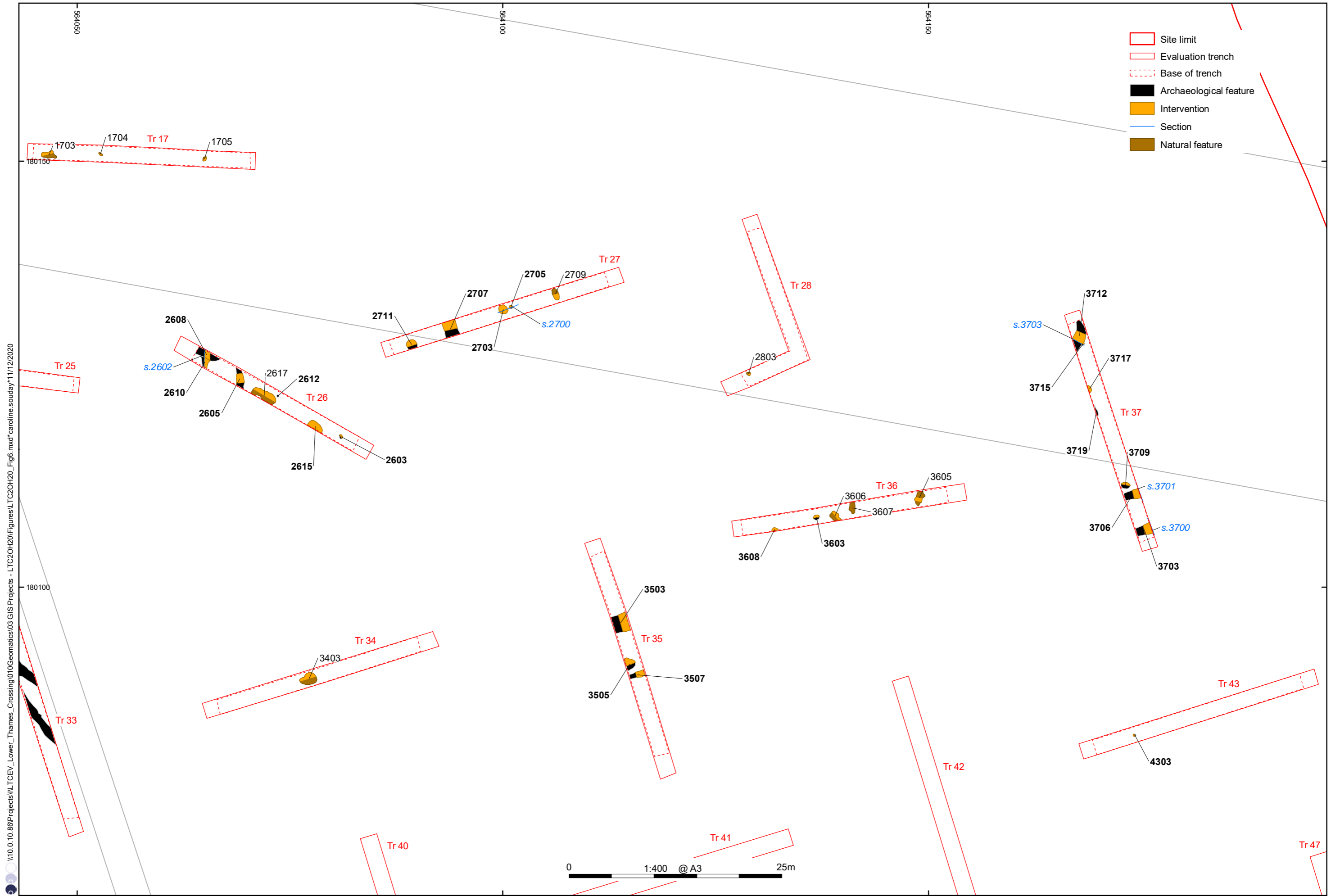

Figure 5: Section 600: SSW facing section showing natural feature 605, Section 1400: ENE facing section showing pit 1403, Section 2500: NE facing section through ditch 2503



\\10.0.10.86\Projects\ILTCEV\_Lower\_Thames\_Crossing\010\geomatics\03\GIS\Projects - LTC2OH20\Figures\LTC2OH20\_Fig6.mxd\*caroline.souday\*11/12/2020

Contains Ordnance Survey data © Crown copyright and database right 2020, provided by client

Figure 6: East side of Land Parcel 2: Trenches 26-28, 34-37 and 41-43

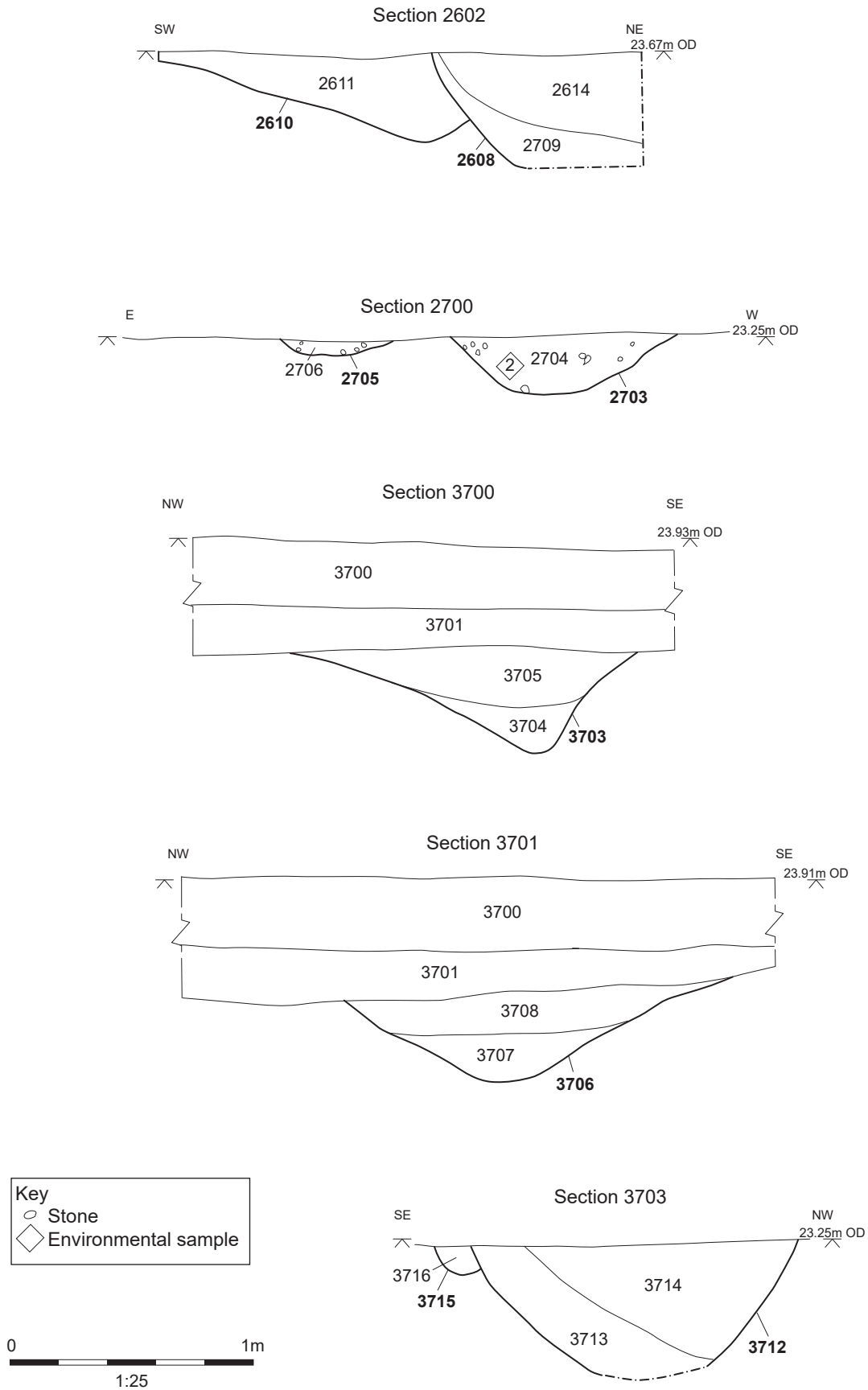

Figure 7: Section 2602: SE facing section through intercutting pits 2608 and 2610,  
 Section 2700: NNW facing section through pit 2703 and posthole 2705,  
 Section 3700: SW facing section through ditch 3703,  
 Section 3701: SW facing section through ditch 3706,  
 Section 3703: NE facing section through posthole 3715 and ditch 3712





Plate 1: South facing section 600 of natural feature 605



Plate 2: East facing section 1400 of pit 1403



Plate 3: North-east facing section 2500 of ditch 2503



Plate 4: South-east facing section 2602, pits 2608 and 2610



Plate 5: North facing section 2700, pit 2703 and posthole 2705



Plate 6: South-west facing section 3700 of ditch 3703



Plate 7: South-west facing section 3701 of ditch 3706



Plate 8: North-east facing section 3703 of ditch 3712 and posthole 3715

**COVER SHEET**

<b>Title:</b>	<b>Archaeological Evaluation Report for Trial Trenching of Land Parcels 3 (North), 30 and 35</b>
<b>Project Name:</b>	<b>Lower Thames Crossing Enabling Works</b>
<b>Ref No:</b>	<b>HE540039-BAL-GEN-GEN-REP-HER-00032</b>
<b>Revision No:</b>	<b>P01</b>
<b>Review Date:</b>	<b>02/02/2021</b>
<b>Status:</b>	<b>S2 – Information</b>
<b>No. of Pages</b>	<b>245</b>

<b>Rev</b>	<b>Date of Issue</b>	<b>Revision Status</b>	<b>Originator</b>	<b>Checker</b>	<b>Approver</b>
P01	02/02/2021	S2 For Information	Sam Ashton	Jack Fletcher	Emily Erswell



# Lower Thames Crossing

Archaeological Evaluation Report for Trial Trenching of  
Land Parcels 3 (North), 30 and 35  
Land Bordering the A13 at Orsett, Essex

Document Number: HE540039-BAL-GEN-GEN-REP-HER-00032

**February 2021**



Revision	Production Date	Prepared by	Checked by	Approved for release by	Sections revised
1.0	27th January 2021	Mark Dodd Project Officer Oxford Archaeology	Andrew Simmonds Senior Project Manager (PX) Oxford Archaeology	Internal review only	
1.1	1st February 2021	Mark Dodd Project Officer Oxford Archaeology	Steve Lawrence Senior Project Manager Oxford Archaeology		

This Evaluation Report has been prepared for Highways England in accordance with the terms and conditions of appointment stated in the Lower Thames Crossing (LTC) Technical Partner Contract. LTC cannot accept any responsibility for any use of or reliance on the contents of this document by any third party.

# Contents

Section	Page
<b>Summary</b> .....	<b>8</b>
<b>Acknowledgements</b> .....	<b>9</b>
<b>1 Introduction</b> .....	<b>10</b>
1.1 Project details and scope of work .....	10
1.2 Location, topography and geology .....	11
1.3 Previous investigations .....	12
1.4 Archaeological and historical background.....	12
<b>2 Project Aims</b> .....	<b>21</b>
2.1 General aims .....	21
2.2 Specific objectives .....	22
<b>3 Methodology</b> .....	<b>24</b>
3.1 Constraints.....	24
3.2 Methodology for the evaluation .....	24
<b>4 Results</b> .....	<b>25</b>
4.1 Introduction and presentation of results .....	25
4.2 General soils and ground conditions.....	25
4.3 General distribution of archaeological deposits .....	25
4.4 Trenches 146-50 (Figs 5 and 6).....	26
4.5 Trenches 141-5 (Figs 7 and 8).....	28
4.6 Trenches 134-7 and 139-40 (Figs 9 and 10).....	31
4.7 Trenches 120-2 (Figs 11 and 13).....	32
4.8 Trenches 156, 165 and 192 (Figs 12 and 13) .....	33
4.9 Trenches 172-4 and 176 (Figs 14 and 15).....	33
4.10 Trenches 169-70, 177, 179 and 183-4 (Figs 16 and 17).....	34
4.11 Trenches 186-9 (Figs 18 and 19).....	35
4.12 Trenches 40, 42-4, 46-8 and 51 (Figs 20 and 21).....	36
4.13 Trenches 55-5, 58 and 61-3 (Figs 22 and 23).....	37
4.14 Trenches 66, 69, 70 and 72-5 (Figs 24 and 25).....	39
4.15 Trenches 68, 71, 76, 82, 89, and 90 (Figs 26 and 27) .....	40
4.16 Trenches 78, 105-6 and 112-14 (Figs 28 and 29).....	41
4.17 Trenches 98-100 and 108 (Figs 30 and 31).....	43
4.18 Trenches 83-6 and 92-3 (Figs 32 and 33).....	43
4.19 Trenches 88, 95-66, 102-4 and 111 (Figs 34 and 35).....	44
4.20 Trenches 1, 5-7, 14, 15 and 17 (Figs 36 and 37).....	45
4.21 Trenches 8-11, 13 and 22 (Figs 38 and 39).....	47
4.22 Trenches 24, 25, and 27 (Figs 40 and 41) .....	48
4.23 Trenches 31-5 (Figs 42 and 43).....	49
4.24 Finds summary .....	50
4.25 Environmental summary .....	51
<b>5 Discussion</b> .....	<b>52</b>
5.1 Reliability of field investigation .....	52
5.2 Interpretation.....	52



5.3	Evaluation objectives and results.....	55
<b>Appendix A</b>	<b>Trench Tables .....</b>	<b>58</b>
<b>Appendix B</b>	<b>Finds Reports .....</b>	<b>150</b>
<b>Appendix C</b>	<b>Environmental Reports .....</b>	<b>174</b>
<b>Appendix D</b>	<b>References .....</b>	<b>186</b>
<b>Appendix E</b>	<b>Abbreviations and Glossary .....</b>	<b>190</b>
<b>Appendix F</b>	<b>Site Summary.....</b>	<b>191</b>

## Figures

Figure 1: Site location

Figure 2: Trench layout and cropmark features, Land Parcels 3 (North), 30 and 35

Figure 3: Trench layout showing archaeological features and cropmarks, Land Parcel 30 and 3 (North)

Figure 4: Trench layout showing archaeological features and cropmarks, Land Parcel 3 (North) and 35

Figure 5: Detailed plan of Trenches 146-50

Figure 6: Sections, Trenches 146-50

Figure 7: Detailed plan of Trenches 141-5

Figure 8: Sections, Trenches 141-3 and 145

Figure 9: Detailed plan of Trenches 134-7, 139 and 140

Figure 10: Sections, Trenches 134, 136, 139 and 140

Figure 11: Detailed plan of Trenches 120-2

Figure 12: Detailed plan of Trenches 156, 165 and 192

Figure 13: Sections, Trenches 120, 156, 165 and 192

Figure 14: Detailed plan of Trenches 172-4 and 176

Figure 15: Sections, Trenches 172, 174 and 176

Figure 16: Detailed plan of Trenches 169, 170, 177, 179 and 183-4

Figure 17: Sections, Trenches 177, 179 and 183-4

Figure 18: Detailed plan of Trenches 186-9

Figure 19: Sections, Trenches 186-8

Figure 20: Detailed plan of Trenches 40, 42-4, 46-48 and 51

Figure 21: Sections, Trenches 40, 42-3, 46-8 and 51

Figure 22: Detailed plan of Trenches 55-6, 58 and 61-3

Figure 23: Sections, Trenches 56, 58, 61 and 62

Figure 24: Detailed plan of Trenches 66, 69, 70 and 72-5

Figure 25: Sections, Trenches 66, 69, 72 and 73

Figure 26: Detailed plan of Trenches 68, 71, 76, 82, 89 and 90

Figure 27: Sections, Trenches 71, 76 and 90

Figure 28: Detailed plan of Trenches 78, 105-6 and 112-14

Figure 29: Sections, Trenches 78, 105-6 and 112-14  
Figure 30: Detailed plan of Trenches 98-100 and 108  
Figure 31: Sections, Trenches 98-100  
Figure 32: Detailed plan of Trenches 83-6 and 92-3  
Figure 33: Sections, Trenches 83-5 and 93  
Figure 34: Detailed plan of Trenches 88, 95-6, 102-4 and 111  
Figure 35: Sections, Trenches 88, 95, 96, 102 and 104  
Figure 36: Detailed plan of Trenches 1, 5-7, 14, 15 and 17  
Figure 37: Sections, Trenches 1, 5-7, 15 and 17  
Figure 38: Detailed plan of Trenches 8-11, 13 and 22  
Figure 39: Sections, Trenches 8-10, 13 and 22  
Figure 40: Detailed plan of Trenches 24, 25, and 27  
Figure 41: Sections, Trenches 24, 25, and 27  
Figure 42: Detailed plan of Trenches 31-5  
Figure 43: Sections, Trenches 31, 33 and 34

## Plates

Plate 1: Trench 148, looking east  
Plate 2: Ditch 15002, looking south-east  
Plate 3: Section 14100 through ditches in Trench 141, looking south  
Plate 4: Ditch 14309, looking west  
Plate 5: Ditch 14002, looking north-east  
Plate 6: Cremation 13610, looking north-west  
Plate 7: Ditch 13502, looking north-east  
Plate 8: Ditch 18606, looking west  
Plate 9: Posthole 4313, looking east  
Plate 10: Pit 7603, looking east  
Plate 11: Feature 9804, looking south-west  
Plate 12: Ditch 8406, looking south  
Plate 13: Pit 10404, looking north-west

Plate 14: Pottery dump in pit 10404

Plate 15: Ditches 11104 and 11106, looking north

Plate 16: Postholes 103, 105 and 107, looking north-west

Plate 17: Pit or posthole 703, looking east

Plate 18: Ditch 3105, looking north

## Tables

Table 1: Prehistoric pottery assemblage

Table 2: Quantification of late Iron Age and Roman fabrics

Table 3: Quantification by EVE of Roman pottery forms

Table 4: Description of post-Roman pottery by context

Table 5: Flint assemblage

Table 6: Ceramic building material assemblage

Table 7: Description of metalwork by context

Table 8: Description of glass assemblage by context

Table 9: Assessment of bulk samples

Table 10: Animal bone assemblage, number of fragments by context and taxon

Table 11: Summary of osteological findings

Table 12: Bone weights per body region

## Summary

---

Oxford Cotswold Archaeology was commissioned by Balfour Beatty to undertake a trial trench evaluation of Land Parcels 3, 30, 31, 32, 34, 35, 103, 104 and 107 covered by WSI G of the Lower Thames Crossing Pre-Enabling Works. These Land Parcels are located either side of the A13, to the south and east of Orsett within the county of Essex and Thurrock unitary authority (NGR 564149, 180821). A total of 167 trenches were dug and recorded between 28th September and 27th October 2020 across Land Parcels 3, 30 and 35. Land Parcels 31, 32, 34, 103, 104, and 107 were not accessible during this phase of fieldwork.

The evaluation revealed a range of archaeological activity dating from the early Neolithic onwards. A single pit containing early Neolithic pottery and flint was recorded in the north-east corner of Land Parcel 30 and residual artefacts of the same date were also recovered from the same area. The evaluation revealed scattered evidence for Bronze Age and Iron Age settlement, predominantly from Land Parcel 30, but across all three parcels. This was represented by a low density of small ditches and discrete features with small quantities of finds dating to these periods, providing an indication of dispersed settlement and associated field systems through the later prehistoric period, although the limited size of the pottery assemblage and lack of diagnostic pieces has made it difficult to determine the periods of activity more precisely.

Rectilinear cropmarks indicating ditched enclosures around Heath Place and Hornsby Lane were confirmed to be Roman in date. The main phase of occupation took place from the early Roman period and peaked by the end of the 3rd century with little to no evidence that it continued into the 4th century. Evidence from Trenches 135 to 150 revealed that the activity was well-defined within the ditched enclosures, and concentrations of pits and postholes with associated finds assemblages clearly demonstrate domestic settlement. Evidence for associated industrial activities is limited, based on the artefact assemblages and environmental evidence, but trial trenching from Hornsby Lane to the south and east has shown that these enclosures were linked to both pottery production and agricultural economies. The rectilinear system of cropmarks to the north of the A13 are likely to be of Roman date and also indicate a focus on an agricultural economy, but due to their peripheral location very few of these features provided reliable dating evidence.

Archaeological evidence for the post-Roman period was sparse and consisted of a single pit of early/middle Anglo-Saxon date in Trench 76, a medieval pit in Trench 104 and late medieval pottery from a ditch in Trench 114. During the post-medieval period, the site was almost entirely used for agricultural activity.

A large number of undated features were also recorded from across the different Land Parcels. These included three unurned cremation burials in Trench 136 but also many pits, postholes and ditches.

## Acknowledgements

---

Oxford Cotswold Archaeology would like to thank the client, Balfour Beatty, for commissioning this project and managing the site safety and attendances. Thanks are also extended to the Historic Environment Consultants (Richard Havis and Katie Lee-Smith) of Place Services at Essex County Council, who advise the Borough of Thurrock, for monitoring and providing advice throughout the project.

The project was managed for Oxford Cotswold Archaeology by Steve Lawrence and the fieldwork was directed by Mark Dodd. Fieldwork in Land Parcel 3 (North) was supervised by Victoria Green, Land Parcel 30 by Ben Slader and Land Parcel 35 by Kat Whithouse. They were supported by Eilidh Barr, Richard Spencer, Heloise Meziani, Rachel Alexander, Ben Camp, Chris Griffiths, Jacopo Gelmi, Nat Pacholek, Joao Heitor, Charlotte Brown, Meagan Mangum, Alex Capon, Stephen Foster, Kerree Kendall, Ellie Brown, Owen Lazarri, Tom Collie, Martha Carruthers, Alice Golton, Beth Hardcastle, James Maccallum, Anne-Laure Bollen, Tamara Hadnagyav, Ed Cole and Christof Heistermann. Site survey was undertaken by Caroline Souday and Jessica Domiczew and digitising was carried out by Caroline Souday and Magda Wachnik.

Thanks are also extended to the teams of OA staff that cleaned and packaged the finds under the management of Leigh Allen and Geraldine Crann, processed the environmental remains under the management of Rebecca Nicholson, and prepared the archive under the management of Nicola Scott.

# 1 Introduction

---

## 1.1 Project details and scope of work

- 1.1.1 The Lower Thames Crossing Project is located between the A2 in Kent and the M25 in the London Borough of Havering. It will run underneath the River Thames through a tunnel and emerge on the northern side of the river at East Tilbury. From the North Portal the road will run to the M25 at Junction 29 via the A13 and pass between North and South Ockendon. The development of the project is managed by LTC, a partnership between Highways England and a consultancy joint venture set up to oversee the scheme.
- 1.1.2 A programme of archaeological trial trenching commenced in the Essex part of the scheme in November 2019. A scheme-wide specification for trial trenching was written by LTC (Highways England 2018), and in July 2019, LTC commissioned Balfour Beatty to deliver the pre-Enabling Works. Balfour Beatty appointed Oxford Archaeology (OA) to prepare a project-wide written scheme of investigation (WSI) for the scheme, which (at the request of the key archaeological stakeholders) is divided into two parts, one for the Kent section and another for Essex and Havering (Oxford Archaeology 2019a; 2019b).
- 1.1.3 Following completion of the project-wide WSIs, OA was instructed to prepare a series of site-specific or group-site-specific WSIs for approval by the key archaeological stakeholders in advance of trial trenching to inform the Development Consent Order. A detailed WSI was created for Land Parcels 3, 30, 31, 32, 34, 35, 103, 104 and 107 prior to the trial trenching (WSI G, Oxford Archaeology 2020a), which details the archaeological background and potential within the site. It also sets out the archaeological aims and objectives appropriate to the investigation of this Land Parcel by trenching and describes the methodology to be applied. The WSI was approved by Richard Havis, Principal Historic Environment Consultant for Place Services at Essex County Council, prior to the start of the fieldwork.
- 1.1.4 Oxford Cotswold Archaeology was commissioned as Balfour Beatty's archaeological contractor to undertake the evaluation in accordance with the approved WSI and local and national planning policies. At the time of the evaluation, only Land Parcels 3 (North), 30 and 35 were available for trenching. The fieldwork in Land Parcels 3 (North), 30 and 35 was completed between 28 September and 27 October 2020.
- 1.1.5 All work followed the MoRPHE Project Manager's guide (English Heritage 2015), and the Code of Conduct of the Chartered Institute for Archaeologists. The archaeological works adhered to the standards and guidance for archaeological evaluation, excavation and archiving (CifA 2014a; CIFA 2014b).
- 1.1.6 The work was monitored by Richard Havis and Katie Lee-Smith of Place Services on behalf of the Borough of Thurrock.

## 1.2 Location, topography and geology

- 1.2.1 The area covered by WSI G lies within the county of Essex and Thurrock unitary authority (NGR 564149, 180821) and is located either side of the A13 south of the village of Orsett, and also extends up the west side of the village (Fig. 1). The WSI covers an area of 95.96ha. Land Parcels 31, 34, 35 and 103 are located just north of the A13, crossing Mill Lane, Rectory Road and the A128, and Land Parcels 3 (North), 30, 32, 33 and 104 are located south of the A13 and either side of the A1013. The easternmost of these, Land Parcel 104, lies immediately north of the modern suburb of Orsett, separate from the historic village centre. A further corridor runs north to the west of Orsett across the B188 and then west through Land Parcels 105–7 around the hamlet of Baker Street. Land Parcel 3 is part of a large field, the southern part of which was the subject of a separate WSI (WSI C), which has already been evaluated by trenching. The parts of Land Parcel 3 within WSI G are called Land Parcel 3 (North).
- 1.2.2 The bedrock geology of the majority of WSI G is Lambeth Group gravels with a small amount of Thanet Sand at the southern edge of the site (BGS 2020). The superficial geology of the site is mixed, the Lambeth Group gravels and the Thanet Sand being overlain in the western third of the site by the Boyn Hill Gravel Member (sand and gravel) and in the central third by a band of Head Clay running from NW–SE along a dry valley. Patches of Black Park sand and gravel overlie the eastern part of the site. Parts of the corridor west of Orsett and the area immediately north of the Orsett suburb have no recorded superficial deposits.
- 1.2.3 Land Parcels 30, 31, 33 and 3 form part of larger arable fields whilst Land Parcels 32 and 34 are made up of small pasture fields. Mobbs Farm is located west of Mill Lane within Land Parcel 34. Land Parcels 105 and 106 are arable, while Land Parcel 107 is a mixture of pasture and arable fields. Within the 1km site buffer the land use is a mixture of agricultural land and urban development associated with the village of Orsett. The village of Orsett is split, the northern historic core of the village situated 0.5km north (and east) of the site and the modern housing estates of Orsett located to the south-east, just south of the site. The area between Land Parcels 3 (North) and 104 west of the junction of the A13 and the Brentwood Road is used as a recycling centre and also as a quarry. The area is also divided by the A13, A1013 and the A1089, which have displaced the historical field boundaries.
- 1.2.4 The eastern part of the site (Land Parcels 31–33, 35, 105, the eastern part of 3 (North), 103 and 104) lies upon an upland area to the south and west of Orsett. A dry valley crosses the western part of the site orientated north-west to south-east, and this includes the western part of Land Parcels 30 and 34 and the western part of Land Parcel 3 (North). West of this the ground rises again. The eastern part of the site rises sharply up to the gravel terrace, which is at 30–34m aOD. To the east the Boyn gravel terrace is lower than on the west, approaching 26m aOD. The Mar Dyke river lies 2.7km to the north-west, and this is the nearest large river to the site.



## 1.3 Previous investigations

- 1.3.1 A small archaeological excavation was undertaken immediately south of Land Parcel 31 in 1979 during the widening of the A13. The results of this investigation are discussed below (Wilkinson 1988).
- 1.3.2 In 1946 a rhomboidal, double-ditched enclosure was identified by aerial photography within the eastern part of the site. This site, known as 'Orsett Cock' was trial-trenched in 1956–7 and watching briefs took place in 1960–61 and in 1968–70 as part of the laying of gas pipelines. This site was subsequently excavated in 1976–9 in advance of the A13 widening. The archaeological investigations found that this site was occupied as a defensive enclosure in the middle to late Iron Age and subsequently as a farmstead with pottery kilns during the Roman period. Evidence was also found of Saxon occupation of Orsett Cock including five sunken-featured buildings (Carter 1998).
- 1.3.3 The A13 was landscaped during the 1970s widening scheme and this landscaping is very likely to have truncated archaeological remains within the footprint of this scheme.
- 1.3.4 In 2018–19 there were junction alterations and further widening to the A13 within the area of the site and for several kilometres north-eastwards. Trial trenching by LP Archaeology was followed by several targeted excavations in 2019, and a summary of the findings of the evaluation and excavation was kindly provided by John Duffy in advance of completion of the report. The investigation was split into eight areas (A-H): Areas E, G and H lay within the site and Areas A and B just south and east respectively. Further east, Area D had already been heavily truncated by the construction of the A13, while Area C 2km to the north-east contained the most archaeology, comprising Mesolithic pits and medieval and post-medieval ditches.
- 1.3.5 Area E, within the A13/A128 junction traffic island, revealed very little surviving archaeology, while trenching further west confirmed linear features known from cropmarks, and recorded further linear features and pits; these were confirmed by small excavations at Areas G and H to the west of the junction, but were mostly undated. A sequence of Roman ditches was also recorded in Area H, just south of Land Parcel 35, and several other ditches contained a small quantity of prehistoric and medieval dating evidence. Areas A and B, east of the A13/A128 junction, also confirmed linear cropmark features, and these were tentatively interpreted as part of a prehistoric field system.

## 1.4 Archaeological and historical background

- 1.4.1 The chronological summary of known archaeology given below is taken from WSI G (Oxford Archaeology 2020a). This covers all of the land parcels within the WSI rather than just the areas accessible within this phase of evaluation fieldwork.
- 1.4.2 **Palaeolithic.** No Palaeolithic finds have been recovered within the site. Palaeolithic finds have been identified 0.2km south of WSI G including four handaxes, one retouched flake and nine flakes. A number of Palaeolithic

finds have also been recorded 0.8–1km south and south-west of WSI G and outside the area of the scheme, including a handaxe and flint flakes.

- 1.4.3 **Mesolithic.** No Mesolithic finds have been recorded within the site. Mesolithic finds spots have been recorded 0.8km south of the site.
- 1.4.4 **Neolithic.** The only known Neolithic find within the site was recovered at Orsett Cock along the line of the A13. A scheduled early Neolithic causewayed enclosure (EH List Entry no. 1009286; Aerial Mapping report site 17A) is located 50m east of the site, and findspots of Neolithic flints have also been recorded in the vicinity.
- 1.4.5 A narrow rectangular enclosure cropmark, aligned east–west with rounded ends is known from aerial photographs in Land Parcel 3 (south) about 100m south of the site, and from its morphology this was suspected to be a mortuary enclosure of Neolithic date. Evaluation trenching, however, indicated that this had been heavily truncated by later agriculture, surviving only as a very shallow ditch, and no dating evidence was recovered (Oxford Archaeology 2020b). This may be a duplicate of a possible long barrow recorded in the HER as 0.2km further south. Neolithic flints have also been recorded across several fields 0.6km south of the site on the boundary of the scheme area.
- 1.4.6 **Early Bronze Age.** The cropmark of a possible ring ditch, which may represent a ploughed-out round barrow, was identified at the western edge of Land Parcel 30 (Aerial Investigations and Mapping Report site 21). An oval ring ditch measuring c 7 x 5m was excavated along the line of the A13 within the eastern part of the scheme (Carter 1998, 165). The ditch contained middle Bronze Age pottery and cremated bone in its upper fills and may have been an early Bronze Age barrow continuing in use into the middle Bronze Age.
- 1.4.7 A large ring ditch is known as a cropmark 180m west of the site, and this is almost certainly of early Bronze Age date. A small cropmark ring ditch lies only 100m north of Land Parcel 31 (Aerial Investigation and Mapping Report site 72), and another small ring ditch, referred to as site 49 by the Aerial Investigation and Mapping Report, was identified 0.5km north of the site. These possibly represent further early Bronze Age barrows.
- 1.4.8 Three early Bronze Age vessels dating to 2500–2000BC were found in a pit within the eastern part of the site during a watching brief on topsoil stripping for the A13 in the late 1970s. This pit was presumed to mark the site of a Beaker burial and lay within an area of multiple cropmarks (Carter 1998, 165).
- 1.4.9 **Later Bronze Age and Iron Age.** WSI G is located 0.5km north-east and south-east of the Orsett (Grey Goose Farm) Cropmark Complex (EH List Entry No. 1002134). This is a scheduled monument that comprises an extensive and dense multi-period site. It includes a number of cropmark small ring ditches, one of which on the west side of the site was shown by evaluation to be of later Bronze Age date, probably representing a burial monument (OA 2020a). The other cropmark ring ditches proved to be of Iron Age date and were probably roundhouse enclosures. Although there was a scatter of pottery of later Bronze Age and early Iron Age date across

this site, this was almost all residual in later features, but supplements the several late Bronze Age to early Iron Age features recorded just south and south-east of this during excavations for the A13 (Wilkinson 1988, 13–16).

- 1.4.10 The eastern part of a prehistoric scheduled monument (EH List Entry No. 1009287) is located within the northern part of the area of WSI G. This monument comprises a circular enclosure that is believed to represent a middle to late Bronze Age Springfield-style enclosure (or ring-fort) and an overlying complex of settlement enclosures containing smaller ring ditches or penannular gullies and pits believed to date to the Iron Age. The large circular enclosure is named after an example excavated at Springfield Lyons, near Chemsford.
- 1.4.11 Despite the evidence of penannular gullies or small ring ditches within it, the integrated complex of enclosures may indicate that this site continued into the Roman period or was in fact largely of Roman date. A pair of converging linear boundaries parallel to the north edge of this enclosure complex may be contemporary, representing a trackway or a succession of boundaries, or could be of much later date, relating to a subdivision of the surviving field pattern.
- 1.4.12 Iron Age settlement activity was recorded west of Rectory Road on the south edge of Land Parcel 31 during the widening of the A13. Four pits (including two grain storage pits), 13 postholes and a possible fence line were recorded (Wilkinson 1988). Two pits contained early Iron Age pottery and two samples of carbonised grain within one of the pits returned radiocarbon date ranges of middle to late Iron Age date:  $160 \pm 80$  BC (HAR 4527) and  $400 \pm 70$  BC (HAR 4635). Other features contained scraps of flint-tempered pottery. This settlement occupied a high point on the Boyn Hill terrace although the excavation also recorded a mixed loamy layer which covered the gravels. This superficial layer, probably Head Clay, covered cropmarks in this area, restricting their identification from aerial photographs (Wilkinson 1988).
- 1.4.13 The Orsett Cock excavation at the A13 roundabout within the eastern part of the site found a scatter of residual middle Iron Age pottery. During the late Iron Age, a sub-square enclosure was constructed along with a timber posthole building. This was followed by a larger triple-ditched enclosure of late Iron Age/early Roman date. A number of Iron Age spearheads were found within the backfill of the triple-ditched enclosure (Carter 1998). Two large oval pits containing early Iron Age pottery, a loom weight and hearth debris were recorded in a watching brief 0.5km east of the Orsett Cock enclosure and within the eastern part of the site.
- 1.4.14 A number of other features and cropmarks have been recorded close to the Orsett Cock enclosure. This includes a cropmark probable enclosure and pits that were identified by the aerial survey (site 72) within Land Parcel 31 and within the rest of the field to the north. There is also a cropmark complex (Aerial Survey site 16) in the fields to the east and within the north-eastern part of the site. These extensive cropmarks cover an area of 90ha. The north-westernmost element of this is a partial curvilinear enclosure with a probable cluster of pits, and only 80m east of this is a sub-rectangular large enclosure containing a penannular enclosure, both of which may well be

later prehistoric. Some 200m east again there is a small ring ditch and another sub-rectangular enclosure, together with a scatter of discrete features, all of which may be prehistoric. The site includes several linear features, rectilinear features and a circular feature within the south-eastern part of this cropmark complex. A number of linear features corresponding to cropmarks were found south and east of the site during the 2018–19 A13 archaeological works. Most of these did not produce dating evidence, although some in Areas A and B were tentatively dated to the prehistoric period (J Duffy pers. comm.).

- 1.4.15 The Neolithic causewayed enclosure (EH List Entry No. 1009286) located 50m east of the site was overlain by an unenclosed early Iron Age site and a middle Iron Age sub-rectangular enclosure (Hedges and Buckley 1978, 219–308). Cropmarks including pits, linear features and ring ditches extend from the area of the scheduled early Iron Age enclosure both south-west and north-west (Aerial Mapping Report sites 17A, 17B and 72). Within these another sub-rectangular enclosure may also be of Iron Age date.
- 1.4.16 A large quantity of high-status Iron Age material was recovered by metal detectorists adjacent to the site. This findspot may have been located within an extensive rectilinear enclosure located in the vicinity of the Iron Age finds in Land Parcel 3 (South). Evaluation has shown that a group of smaller enclosures on the east side of this were of late Iron Age or very early Roman date, but that the major part of the enclosure was of Roman date (OA 2020b). Two Iron Age vessels were also found just north of Land Parcel 34 and are now kept in Orsett Church.
- 1.4.17 **Roman period.** During the late Iron Age/early Roman period a triple-ditched enclosure measuring c 90m long by 80m wide was constructed at Orsett Cock within the eastern part of the site. This continued in use throughout much of the Roman period, with a succession of round and rectangular buildings and four pottery kilns. The site was interpreted as a Romano-British farmstead that developed into a pottery production site (Carter 1998, 1–10). Early Roman pottery was also found just south-east of Orsett Cock and just at the edge of the site. Another Roman enclosure was recorded before the A13 widening within the easternmost part of the site, but only the south-east corner of this enclosure was recorded. North-west of the Orsett Cock enclosure is an extensive complex of cropmark enclosures, trackways, fields and probable pits. The south-eastern part of this complex is located within the north-eastern part of the site. A rectilinear arrangement of trackways or double ditches is orientated on the same alignment as some of the post-medieval field boundaries, so these may be late in date, but they incorporate a large sub-rectangular enclosure that is thought more likely to be of late prehistoric date, suggesting that the system may well prove to be Roman. Several linear features and part of a possible trackway are located within the area of the site. A sequence of Roman ditches was recorded in Area H south-west of the Orsett Cock junction during the 2018–19 A13 archaeological works (J Duffy pers. comm.) and were presumably related to the Orsett Cock triple-ditched enclosure.
- 1.4.18 The lines of two possible Roman roads cross the eastern part of the site. The more westerly of these roads is on a NNW–SSE alignment and is

believed to pass between the Orsett Cock enclosure and the Roman enclosure further to the east. The other proposed Roman road lies further east and is suggested as running on a NW–SE alignment from Orsett Hall to East Tilbury. Two Roman findspots were recorded close to the line of the western road, but no definite evidence for these roads has been recorded.

- 1.4.19 Another extensive cropmark complex that includes one very large rectilinear enclosure and several smaller ones linked by trackways or field boundaries was identified by the aerial survey partially within the southern part of the site (Aerial Investigations and Mapping Report site 20). The large enclosure is on a north-west to south-east alignment and contains subdivisions, pits and curvilinear smaller enclosures. Recent trial trench evaluation for the scheme in Land Parcel 3 (South) has revealed ditches and other features belonging to the southern part of an enclosure containing Roman pottery, confirming their Roman date (OA 2020b). Pottery kilns were also discovered in the area of WSI C in Land Parcel 3 (South).
- 1.4.20 A cluster of Roman find spots have been recorded just north of the settlement of Orsett and 0.5km east of the site. This suggests Roman activity in this area.
- 1.4.21 In the wider area, several possible Roman sites lie on the gravel ridge 0.5–1.5km north-west of the site. These comprise a late Iron Age to late Roman farmstead, the scheduled Orsett (Grey Goose Farm) Cropmark Complex (EH List Entry No. 1002134), which evaluation has shown includes Roman enclosures (OA 2020a), and another possible Roman enclosure just to the east of it.
- 1.4.22 **Medieval period.** Early to middle Saxon activity has been identified east and south-east of the Land Parcel. A Saxon settlement was located at Orsett Cock, within the eastern part of the site in the area previously occupied by the Roman settlement enclosure. The Saxon occupation of the Orsett enclosure comprised five sunken-featured buildings with associated pottery dating to the 6th and 7th centuries. Several further buildings were found outside the enclosure to the east along the A13 and north-east at Barrington’s Farm within the site (Milton 1987). During the excavations at Barrington’s Farm six Saxon features were recorded including three sunken-feature buildings, and these contained Anglo-Saxon pottery dating to AD 400–700. Other features probably of Saxon date were also found in this area. Several undated field boundaries post-date these early Saxon features and indicate that a later field system was imposed on this area (Carter 1998). These are likely to be later medieval or post-medieval field boundaries.
- 1.4.23 The Orsett Neolithic causewayed enclosure (EH List Entry No. 1009286) located 50m east of the site was reused as a Saxon cemetery comprising five small ring ditches in the 7th–8th centuries. The aerial investigation and mapping survey that was undertaken as part of the project identified a large number of linear cropmarks and pits around the causewayed enclosure, which may date from the prehistoric to the medieval period (Aerial Investigation and Mapping Report site 17). The cropmark of a similar penannular small ring ditch is visible 200m north-west of the Orsett Cock enclosure and may indicate another middle Saxon burial site.

- 1.4.24 A dense pattern of individual cropmarks of varying size and shape are dispersed across the Orsett Cropmark Complex (EH List Entry No. 1002134; Aerial Investigation and Mapping Report sites 13 and 14) located 0.3km west of the site. These were interpreted as pits, and some were thought likely to represent Saxon sunken-featured buildings (Place Services 2019). Evaluation of this site has not, however, produced any Saxon finds, and the discrete cropmarks have mostly proved to be geological in origin (OA 2020a). A Saxon clay loomweight was, however, recovered from work along the line of the A13 south of the monument (Wilkinson 1988).
- 1.4.25 Some of the discrete features identified from cropmarks within Land Parcels 30 and 35 are also of similar size to sunken-featured buildings, but these may also prove to be geological, or alternatively, as the 'pits' are of a variety of sizes and shapes, some rather irregular, many may prove to be small quarries of medieval or later date.
- 1.4.26 In the late Saxon and later medieval period the site was located within the manor and parish of Orsett. The Domesday survey recorded the settlement of Orsett as having 61 householders, 30 plough teams, six cattle, 40 pigs and 115 sheep in 1086. This manor belonged to the Bishops of London (St Paul's). This manor also had enough woodland to accommodate 1000 pigs (Palmer 2019). This documentary evidence suggest that the economy may have been a mixture of arable and pastoral and that some parts of the parish were wooded.
- 1.4.27 Bishop Bonner's Palace is a scheduled monument (EH List Entry No. 1002196) located 0.3km north-east of the site. This ring and bailey earthwork is likely to date to between the late Saxon period and the later 12th century and may have been the seat of the Orsett manor belonging to the Bishops of London as mentioned in Domesday.
- 1.4.28 The later medieval nucleated settlement of Orsett was located just outside the site on the north and east. The church of St Giles and All Saints is Grade I listed (EH List Entry No. 1147049) and is located c 0.5km east of the site. This church dates to the 12th century. It is likely that in the later medieval period the Land Parcel was used as agricultural land associated with the settlement of Orsett. A number of roughly north-south aligned droveways have been observed as cropmarks within the wider area and these may have been used to take livestock to and from the marshland and the upland ridge. Mill Lane and Rectory Road may be medieval in origin, and a group of cropmark trackways south of Orsett on either side of Rectory Road and on the same orientation or at right angles may also date from the medieval period, as may some of the enclosures within this system. One of these possible droveways passes through the north-eastern part of the site, although this may instead be earlier in date.
- 1.4.29 **Post-medieval period.** Documentary evidence indicates that the site was situated either side of a SW-NE road from Stifford to Stanford. The site was also located 0.5km south and 0.4km west of the village of Orsett and 0.5km north-east of the hamlet of Orsett Heath. Several NNW-SSE aligned roads are shown in the vicinity of the site on the 1840 tithe map of Orsett (D/CT 264/1a) and the late 19th-century OS maps. This includes Baker Street and

Fen Lane, located to the west and north-west of the site, and Mill Lane, Rectory Road and the small track west of Barrington's Farm, which bisect the centre and eastern part of the site.

- 1.4.30 A number of listed buildings are located in close proximity to the site, but not within the site itself. The majority of these are post-medieval buildings situated in the nucleated settlement of Orsett, and these will not be discussed in detail.
- 1.4.31 Orsett Hall was the major manor house for this area and was located 900m north of the site, but it burnt down in 2007 leaving only a boundary wall (EH List Entry No. 1392465). Orsett Hall was the seat of the Manor of Orsett and this may have incorporated land originally belonging to the medieval Bishop Bonner's Palace (EH List Entry No. 1002196). The south-eastern part of the site, adjacent to the Orsett causewayed enclosure (EH List Entry No. 1009286), may have belonged to Seaborough Hall, a post-medieval manor house that was demolished in the early 20th century.
- 1.4.32 The listed buildings that related to the historic land use of the north and north-western part of the site include the Old Hall Farm House (EH List Entry No. 1111592), Orsett House (1111610) and Poplars Farmhouse (1146717). Three 18th-century farmhouses are located in the vicinity of the southern and eastern parts of the site including Whitecrofts Farmhouse (1111566), Heath Place (1111575) and Loft Hall (1111649). There are also several cottages that are listed in the vicinity of the site including a 17th-century cottage (1111644) and a pair of 19th century cottages (1337056) along Baker Street, the 18th-century Murrells Cottages (originally named Prattocks) (1337096) along the Stifford–Stanford Road and Slades Hold Cottages dating to the 17th century (1111608) along High Road.
- 1.4.33 Several non-designated post-medieval farm buildings and cottages were located within or close to the site along Baker Street, Mill Lane and the Stifford-Stanford Road. This includes a post-medieval post mill that was located west of Mill Lane and just east of the site. The circular base for this mill is extant and may date to the 17th century. Five Chimney Cottages were located within Land Parcel 30 and adjacent to the Stifford–Stanford Road (now the A1013). The 1840 tithe map and the OS map of 1873 show several buildings at Five Chimneys, which were replaced by the mid-20th century with one long building. Potash Cottages were located in Land Parcel 32 and adjacent and north of the Stifford–Stanford Road. These cottages are shown on the 1840 tithe map and the OS map of 1873 and were also demolished by the mid-20th century, although there appear to have been cottages south of the A1013 that were also called Potash Cottages.
- 1.4.34 The Stifford–Stanford Road (A1013) appears to have been widened in the mid-20th century, which may have led to the demolition of several buildings along its route. Mobbs Farm was located just west of Mill Lane within Land Parcel 34. The tithe map indicates this farm belonged to the Orsett Poor and it is shown on subsequent later 19th century OS maps. There is still a farm at this location, although the original farm buildings may have been demolished. Another terrace of cottages was located in the eastern part of the site and north of the Stifford–Stanford Road. These cottages were

shown on the 1841 tithe map and on the late 19th-century and 1920s OS maps as Ridgwell Cottages. These cottages are not shown in OS mapping after the 1930s and so must have been demolished by this date. Other farmhouses located in the vicinity of the site included Barringtons Farm and Cock Farm just east of the site and Nevilles Farm located just west of Land Parcel 30.

- 1.4.35 Orsett House is a Grade II\* listed building and is located 70m east of the site. This building was constructed in 1740 for Captain Samuel Bonham (Bettley and Pevsner 2007, 619) and the tithe map indicates that Orsett House remained in the Bonham family until at least the mid-19th century. In the later post-medieval period, the Land Parcel was used as agricultural land associated with several farmsteads in the vicinity. The 1841 tithe map provides details of the tenants and the land use at the time.
- 1.4.36 The area of the site has seen a number of developments in the 20th century (including the A13) which have impacted on the historic landscape. Several post-medieval field boundaries are preserved within the site including two linear field boundaries in Land Parcels 30 and 3 (North) which were shown on the tithe map of 1841.
- 1.4.37 During the Cold War a nuclear monitoring post was constructed to the north of the A13 within the boundary of the site. Monitoring posts were constructed below ground with equipment on the surface. It is possible there may be remains of this structure below ground (Subterranea Britannica 2019).
- 1.4.38 In the later 20th century a new housing estate was built immediately south-east of the site which became an outlying part of the settlement of Orsett, located south of the A13. During this period several fields in the vicinity of the site were subjected to quarrying. In the 1960s the fields directly north of Land Parcel 34 were quarried, and this may have extended southwards into the Land Parcel. In the late 1970s/early 1980s the route of the A13 was landscaped in advance of the A13 widening scheme. This caused disturbance of areas of land directly west and north of the site. It is possible that further areas of the site may have been truncated by the A13 scheme, although how far this disturbance extended beyond the footprint of the A13 is unknown.
- 1.4.39 **Undated features and cropmarks.** Cropmarks identified within the southern part of the site and just to the south include linear features, a curvilinear feature and a possible double-ditched trackway. These have been identified by aerial photographs (Aerial Investigations and Mapping Report site 17A). It is possible that these features may be later prehistoric or Roman in date, but there is insufficient evidence to characterise them as such.
- 1.4.40 A number of cropmarks have been identified south-west and west of the site and south of the A13 (Aerial Investigations and Mapping Report sites 21 and 23). The area to the west of Nevilles Farm, 0.5km west of the site, includes cropmarks of possible enclosures, linear features, large sub-circular pits and a ring ditch. Further east, and immediately south of Land Parcel 30, extensive groups of pits were identified across a wide area. A cropmark complex just south of Orsett is also currently undated. These



cropmarks could be dated to the prehistoric, Roman, Saxon or medieval periods, as demonstrated from nearby activity, and have been discussed under the relevant chronological headings above.

## 2 Project Aims

---

### 2.1 General aims

2.1.1 The general aims of the project were as follows:

- i. To establish the presence or absence of archaeological remains along the line of the scheme, and the extent of any areas where remains appear likely to be absent.
- ii. In areas where archaeological remains are known or suspected, to clarify the reliability of the cropmark or geophysical survey evidence.
- iii. In areas where no archaeological remains are indicated by aerial or geophysical survey, to clarify whether this apparent absence of remains is genuine.
- iv. To determine the degree of complexity of any surviving horizontal or vertical stratigraphy, and in particular to investigate areas where topography indicates the likelihood of deep deposit sequences for evidence of buried archaeological horizons and palaeo-environmental sequences.
- v. Where remains are present, to determine the period(s) represented, the extent, state of preservation and character of the archaeological remains.
- vi. To establish the range and state of preservation of archaeological artefacts, and through their recovery and examination, to establish the potential for information about the economy, status and contacts of past inhabitants of the scheme footprint.
- vii. To determine whether palaeo-environmental remains are preserved, and, where these are found, to determine their types (eg charred plant remains, waterlogged remains, molluscan remains), state of preservation and potential for environmental information. This will be achieved through the recovery of samples from sedimentary sequences and archaeological features suitable for assessment of a range of palaeoenvironmental remains (eg charred and waterlogged plant remains, charcoal, insects, pollen, diatoms, ostracods/foraminifera and molluscs) and scientific dating (eg radiocarbon and OSL dating).
- viii. To investigate and record the extent, character and chronology of the sedimentary sequences, in particular those immediately adjacent to and in floodplains, contained within palaeochannels or in dry valleys, and to use the data to refine existing geoarchaeological (predictive) deposit models.
- ix. To place any identified archaeological remains into their local and, where appropriate, regional or national context, and to assess the implications of any such discoveries for our current understanding of settlement and landscape change in the area, including an assessment of the associations of any remains with reference to the historic landscape.
- x. To provide sufficient information to enable the LTC archaeological advisor, in consultation with the Key Archaeological Stakeholders, to determine the significance of the archaeological assets identified within the Land Parcel.

- xi. To provide a report on the discoveries to inform the Environmental Statement (ES) supporting the Development Consent Order (DCO) and support the preparation of a further archaeological mitigation strategy for the Enabling Works and Construction phases of the scheme.
- xii. Following the DCO, to deposit the report in the public domain, and to generate an accessible and useable archive which will allow future research to be undertaken.

## 2.2 Specific objectives

2.2.1 The specific project objectives were as follows:

- xiii. To conduct the programme of archaeological investigation within the general research parameters and objectives defined by the revised East of England Research Framework (Medlycott 2011), and to take account of the aims and objectives of the Greater Thames Estuary Historic Environment Research Framework.
- xiv. To clarify through targeting of apparently blank areas whether the cropmarks provide an accurate representation of the range, quantity and types of archaeological features present within the parcel;
- xv. To clarify whether remains of Mesolithic or early Neolithic date exist within the site, and if so, what the relationship of these remains is to the causewayed enclosure, and to the dry valleys and watercourses, particularly the Mar Dyke Valley, within and adjacent to the scheme area.
- xvi. To investigate whether remains of the later Neolithic and early Bronze Age exist within the site, and if so, to establish their character and chronological duration, their relationship to monuments of the same period, and to dry valleys and watercourses, particularly the Mar Dyke Valley.
- xvii. To clarify whether the circular ring ditches within the area of WSI G are the remains of burial monuments or 'shrines' of the Bronze Age, and if so, to establish their date and duration of use within and beyond the period, and to investigate peripheral activity, whether burial, deposits related to visits, or reuse for burial or other purposes in later periods.
- xviii. To further clarify the density and range of sites of the later Bronze Age and Iron Age within the area of WSI G, and (where appropriate) to use both artefactual and scientific dating to assist in establishing whether occupation was long-lasting, repeated or shifting.
- xix. To clarify if there were topographic preferences in the location of later prehistoric sites, ie whether sites are confined to higher ground or also occur within dry valleys and the Mar Dyke Valley, and to determine what contribution (if any) later prehistoric agriculture may have made to the accumulation of colluvium in lower-lying areas within WSI G.
- xx. To establish the extent, character and density of Roman activity within the area of WSI G, and in particular, whether the undated cropmark enclosures north of the A13 are Roman, and if so, establish their duration of use.
- xxi. To determine whether further evidence of pottery production is present within the area of WSI G, and if so, to date and characterise this. To

investigate whether there is any physical evidence of the Roman roads believed to cross the eastern part of the site.

- xxii. To establish the character and date of the widespread pit -like cropmarks across the area of WSI G, and to determine whether these are all archaeological, and, where proven to be so, if they are of one type or period or whether they encompass several types and span several periods of activity.
- xxiii. To clarify the extent and character of the Saxon activity around that found on the A13 at Orsett Cock, and clarify the date and development of this within the Saxon period and its relationship to the middle Saxon burials found at the causewayed enclosure site to the south.
- xxiv. To establish the date of the possible medieval or post-medieval field boundaries that have been identified within the area of WSI G, and whether there is evidence that some of the roads crossing the area may be of medieval origin, perhaps droeways, and have medieval settlements or agricultural structures associated with them.
- xxv. To look for evidence of medieval and post-medieval farmsteads that are recorded on historic maps within the area of WSI G.

## 3 Methodology

---

### 3.1 Constraints

- 3.1.1 As well as limited land access, several other constraints have restricted the area of the site available for trial trenching. These include services and unexploded ordnance (UXO). There are high voltage overhead electricity lines crossing Land Parcel 3 (North) and along the A128, and overhead telecommunication lines along the A1013, along Baker Street, along Rectory Road and along the A128 adjacent to the site.
- 3.1.2 There are a number of buried services that cut across the site or are in very close proximity, including water supplies in Land Parcel 3 (North) and along Baker Street, and gas supplies along the A1013.
- 3.1.3 These limitations were considered when designing the detailed trench layout, but the plotted positions of buried services are often only approximate and due to this and to low-hanging overhead cables it was necessary to adjust the locations of approximately 15 trenches in the field. The approximate locations of all trenches are shown by their numbers in Figures 2–4.
- 3.1.4 The following trenches could not be accessed during the fieldwork and were not excavated at this time.
  - LP 3 (North) – 115, 116, 117, 118, 138, 158, 159, 162 and 163
  - LP 30 – 37, 38, 39, 41, 45, 49, 54, 59, 64 and 67
  - LP 35 – 2, 3, 4, 18, 19 and 36

### 3.2 Methodology for the evaluation

- 3.2.1 The combined land area for Land Parcels 3 (North), 30 and 35 was 32.7ha. A total of 167 trenches were excavated, with three trenches measuring 50m x 2m, one trench measuring 17m x 15m and the remainder measuring 30m x 2m. Combined, these represent a 3% sample of the area available for trenching. The locations of the trenches are shown on Figure 2.
- 3.2.2 The trench design was developed to target cropmark features identified by the aerial investigation and mapping report (Place Services 2019), and otherwise to provide even coverage of the blank areas.
- 3.2.3 All trenches were located using a Global Positioning System (GPS) prior to machine excavation. All trenches were excavated using a tracked excavator fitted with a toothless bucket under constant archaeological supervision.
- 3.2.4 Revealed features were hand cleaned and sampled by hand excavation. They were recording as outlined within the approved WSI. All finds were bagged by context throughout the evaluation and were recovered for further investigation, and soil samples were taken as appropriate.

## 4 Results

---

### 4.1 Introduction and presentation of results

- 4.1.1 The results of the evaluation are presented below and include a stratigraphic description of the trenches that contained archaeological remains. The full details of all trenches with dimensions and depths of all deposits can be found in Appendix A. Finds reports are presented in Appendix B.
- 4.1.2 Context numbers reflect the trench numbers, unless otherwise stated. For example, ditch 803 is a cut within Trench 8, while pit 1719 is a cut within Trench 17.
- 4.1.3 The descriptions are separated and presented by Land Parcel. An overview of the separate Land Parcels and the results for the evaluation is shown on Figures 2–4. Further detailed plans of the trenches that contained archaeological features and selected sections are shown on Figures 5–43.

### 4.2 General soils and ground conditions

- 4.2.1 The soil sequence was broadly similar across the three parcels. Despite the changes in topography, there was little evidence for colluvial accumulation and no buried soil horizons were observed. The natural geology was overlain, where present, by a subsoil deposit which was in turn sealed by the ploughsoil. The composition of the ploughsoil varied between sandy silt and clay silt across the three parcels, depending on the underlying geology.
- 4.2.2 Across parts of Land Parcel 3, particular the higher ground to the east, and some areas of Land Parcel 30 the depth of overburden proved to be remarkably shallow. In some instances, the archaeological horizon was little more than 0.3m beneath the surface.
- 4.2.3 Ground conditions throughout the evaluation were varied due to the differing underlying geology and changes in the weather. Several episodes of heavy rainfall lead to localised flooding in trenches that were excavated onto the less well-drained substrates, but these drained away rapidly.

### 4.3 General distribution of archaeological deposits

- 4.3.1 Archaeological features were located in the following trenches:
- **LP 3 (North)** – 120, 121, 122, 134, 135, 136, 137, 139, 140, 141, 142, 143, 144, 145, 146, 147, 148, 149, 150, 156, 165, 169, 170, 172, 173, 174, 176, 177, 179, 183, 184, 186, 187, 188 and 189
  - **LP 30** – 40, 42, 43, 44, 46, 47, 48, 51, 55, 56, 58, 61, 62, 63, 66, 68, 69, 70, 71, 72, 73, 74, 75, 76, 78, 82, 83, 84, 85, 86, 87, 88, 89, 90, 92, 93, 94, 95, 96, 98, 99, 100, 102, 103, 104, 105, 106, 108, 111, 112, 113 and 114
  - **LP 35** – 1, 5, 6, 7, 8, 9, 10, 11, 13, 14, 15, 17, 22, 24, 25, 27, 31, 32, 33, 34 and 35
- 4.3.2 The evaluation confirmed the presence of several linear and curvilinear features within the site that had been identified as cropmarks by the aerial

investigation and mapping report (Place Services 2019). In Land Parcel 3 (North) in particular, there was a strong correlation between the areas with cropmarks and features revealed by the trenching. In the southern portion of Land Parcel 3 (North), there was a concentration of enclosure ditches and associated discrete features, including several unurned cremations in Trench 136. On the higher ground to the east of the parcel, there was also a focus of activity represented by linear boundary features.

- 4.3.3 In Land Parcel 30 there was a more dispersed pattern of activity evidenced by a range of small pits and ditches appearing in low numbers, but more or less evenly spread across the site. The cropmarks in this Land Parcel provide little indication of the distribution of features, as few cropmark features were identified in this field.
- 4.3.4 Land Parcel 35 also revealed a more dispersed distribution of features, with linear ditches corresponding to the cropmarks previously identified, but also a number of discrete features recorded in the western half of the site.

#### 4.4 Trenches 146-50 (Figs 5 and 6)

- 4.4.1 Trenches 146, 147, 148, 149, and 150 were located at the south end of Land Parcel 3 (North). They were each targeted on the linear enclosure cropmarks identified at this location. Trench 148 was a larger open area trench designed to incorporate possible discrete features also identified from cropmarks.
- 4.4.2 **Trench 146** was located in the south-west corner of the site approximately 30m west of Trench 147. It revealed a single NE–SW aligned ditch (14602). The ditch measured 0.9m wide and 0.3m deep with a concave profile. It contained a single sterile fill (14603). Two possible features were also investigated in the trench (14604 and 14605). These were both interpreted as natural variations, but it is worth noting that 14605 does coincide with a linear cropmark that was recorded as 14708 in Trench 147.
- 4.4.3 **Trench 147** revealed several features including ditches 14702 and 14708. Both features were orientated NE–SW and matched cropmark features targeted by the trench. Ditch 14708 had steep sides and a slightly concave base, 0.9m wide and 0.3m deep. It was filled by a single deposit of grey-brown silty sand and gravel (14709). Ditch 14702 had a similar profile and was 0.63m wide and 0.21m deep. It contained a single deposit of grey-brown, sandy gravel (14703) and produced a single sherd of middle Bronze Age to Iron Age pottery.
- 4.4.4 Three discrete features were also recorded in the trench. Pit 14706 was just 0.31m in diameter and 0.11m deep. It contained a naturally silted, sterile fill of silty sand. Feature 14710 was more likely to be the remains of a posthole. It measured 0.28m in diameter and 0.3m deep with steep sides and a concave base. It was backfilled with a dark brownish grey, silty sand (14711) and produced a very abraded sherd of middle Bronze Age to Iron Age. Pit 14712 was located at the south-east end of the trench and was only recorded in plan.
- 4.4.5 Feature 14704 was interpreted as a ditch terminus. It was only partially exposed, extending beyond the north-east edge of the trench. It was at least

- 0.7m wide but just 0.12m deep. It was filled by an orange-brown primary silting deposit 14705.
- 4.4.6 **Trench 148** was located approximately 20m north-east of Trench 147. It revealed several linear ditches and multiple pits and postholes type features (Plate 1), many of which matched with previously identified cropmarks.
- 4.4.7 Ditch 14802 was orientated NE–SW and aligned with ditch 14702 in Trench 147 to the south-west. It had a concave base and moderately steep sides with a single fill of grey-brown silty clay (14803), which produced a sherd of Roman pottery. The south-east edge of the ditch truncated an earlier shallow pit (14804). It measured just 0.3m in diameter and 0.04m deep, but contained a dark silty fill (14805) from which early Roman pottery was recovered and a bulk soil sample collected. Sample 2 yielded only a few charred vetches and weed seeds.
- 4.4.8 Ditch 14806 was in the south-east corner of the trench on a parallel alignment to ditch 14802. It had a similar profile and contained a similar fill but finds were recovered from this feature. The truncated remains of a posthole (14808) survived on the south-east edge of the ditch. It contained a naturally silted fill of light grey sandy silt. Both the ditch and posthole were disturbed in plan at this location by a natural feature, possible an animal burrow (14810).
- 4.4.9 The south-east ends of ditches 14806 and 14802 appeared in plan to be truncated by perpendicular boundary ditch 14813. Ditch 14813 measured 1.5m wide and 0.48m deep with steep sides and a narrow, almost V-shaped base. It contained a primary fill (14814) of grey-brown sandy silt, overlain by a secondary fill of similar, more stony material (14815). No finds were recovered from this feature. The ditch had an undetermined relationship with an adjacent pit 14811. The pit contained a sterile fill of grey-brown sandy silt and produced no finds.
- 4.4.10 Ditch 14813 was investigated again to the north-west in slot 14818 where it converged with an adjacent ditch on a similar alignment (14820). Although the relationship was not certain, it appeared as though ditch 14818 was truncated by ditch 14820. Ditch 14820 measured 1.26m wide and 0.8m deep. It contained a single fill of dark brown sandy silt (14821) and produced two sherds of Roman pottery. It was partially truncated to the south-west by a shallow pit 14822. It had a shallow concave profile with a dark brown silty sandy fill. No finds were recovered from it.
- 4.4.11 In total, 25 discrete features were recorded in this trench. These comprised a mixture of shallow pits and possible postholes, many of which were recorded in plan only and cleaned for surface finds. Excavated examples 14843 and 14838 were both 0.3m in diameter and less than 0.1m deep with fills of greyish brown sandy silt. It is unclear if these are the remains of small pits or postholes, but presumably they have been truncated significantly since their creation.
- 4.4.12 Pit 14816 appeared in plan to be part of a group of intercutting features. Excavation revealed another shallow feature, just 0.26m deep with a concave profile. It contained a dark brown sandy silt (14817), but this was indistinguishable from the fill of what were initially perceived to be separate



features. The feature or features filled by deposit 14817 correspond with one of the discrete cropmarks targeted by this trench.

- 4.4.13 **Trench 149** was positioned approximately 30m south-west of Trench 148 and immediately south of Trench 147. It revealed a single NW–SE aligned ditch, corresponding to a previously recorded cropmark feature. Ditch 14902 had a broad concave profile, 0.94m wide and only 0.25m deep. It was filled by a naturally accumulated dark brown silty sand deposit (14903).
- 4.4.14 Posthole 14905 was recorded near the centre of the trench. It had vertical sides 0.3m in diameter and survived to a depth of 0.18m. It contained a single naturally silted fill that presumably accumulated after the post had decayed. No finds were recovered from either feature in this trench.
- 4.4.15 Several other possible features were also investigated in this trench but were determined to be variations in the geology (14907, 14908 and 14909).
- 4.4.16 **Trench 150** was located east of Trench 149 and south of Trench 148. It revealed a total of three linear features with ditches 15002 and 15004 on NW–SE alignment at the northern end of the trench and ditch 15006 on a perpendicular alignment at the southern end of the trench. Both boundary features matched the positions of the linear cropmark features targeted by this trench.
- 4.4.17 Ditch 15002 had moderately steep sides and a broad concave base and was 0.84m wide and 0.32m deep (Plate 2). It contained a fill of greyish brown sandy silt (15003) from which a small quantity of Roman pottery was recovered. It was recut along the south-west edge by ditch 15004, which had a similar profile and fill. No artefacts were recovered from this later feature. Based on their alignment they appear to be the continuation of ditches 14820 and 14813 recorded in Trench 148 to the north-west.
- 4.4.18 Ditch 15006 had a very shallow concave profile and was 1.35m wide and 0.16m deep. It was filled by a naturally silted deposit (15007) from which 19 sherds of Roman pottery were recovered. By extrapolating the alignment of the feature using the cropmark information, it appears to form part of an enclosure, and is likely to be broadly contemporary with ditches 15004 and 15002.

## 4.5 Trenches 141-5 (Figs 7 and 8)

- 4.5.1 This group of trenches was located in the southern part of Land Parcel 3 (North), to the west of Hornsby Lane. They were positioned to target a rectilinear pattern of cropmarks that extends to the south and the north-east.
- 4.5.2 **Trench 141** was situated to the north-west of this group at the edge of the Land Parcel. Near the centre of the trench was a complex cluster of intercutting pits and ditches (Plate 3; section 14100). The sequence began with a large NW–SE aligned ditch (14115). It measured 1.54m wide and 0.66m deep and was filled by three successive fills (14116, 14117 and 14120). Several sherds of medieval pottery were recovered from fill 14116. The ditch was then recut on its north-east and south-west sides by ditches 14103 and 14105. Each had moderately steep sides and a concave base but they were shallower, between 0.3m and 0.35m deep. No finds were

recovered from either of these later ditches. Ditch 14115 and its recuts 14103 and 14105 formed part of a linear boundary that is visible as a cropmark and continues to the south-east.

- 4.5.3 Ditch 14105 was truncated by later pit or ditch terminus 14109, which was in turn truncated by feature 14107. Both features were filled by naturally silted brown sandy silt deposits and neither produced any artefacts. Only identifiable in section following excavation, it remains unclear if these were discrete pits or terminal ends of later boundary recuts.
- 4.5.4 To the west of ditch 14105 was small pit or posthole 14118. It had a shallow concave profile and a single fill of brown sandy silt. No artefacts were recovered from this feature.
- 4.5.5 At the western end of the trench and coinciding with a cropmark linear on a perpendicular alignment to the ditches in the centre of the trench were two further ditches (14111 and 14113). Although these were recorded as two separate ditches, the relationship between them was indistinguishable. It is likely they were actually one large cut, at least 2.6m wide and filled by a single deposit of orange-brown sand. No finds were recorded from these contexts.
- 4.5.6 **Trench 142** was excavated as an L-shape to target a pair of linear cropmarks and a nearby discrete feature. It was positioned 35m south of Trench 141, separated by an overhead powerline. Ditch 14203 was located at the western end of the trench on a N–S alignment. It had a shallow concave profile and a single naturally silted fill (14204) of light brown sand, which produced a sherd of undated pottery and a single horse tooth. Ditch 14207 was approximately 3m to the east and orientated NNW–SSE. It also had a shallow concave profile and was filled by a single deposit (14208). A single sherd of early post-medieval pottery as recovered from this ditch.
- 4.5.7 Pit 14205 was partially exposed against the southern edge of the trench. It measured at least 1.12m in diameter and was excavated to a depth of 0.6m, although not bottomed. The earliest fill (14206) was a deliberate dump of material comprising a dark grey silty sand rich in charcoal, middle Roman pottery and fragments of Roman tile. Bulk soil sample 14, collected from this deposit, produced large quantities of charcoal and smaller amounts of charred cereal grains chaff and weed seeds. This layer was sealed by two naturally accumulated fills (14209 and 14210). A single sherd of Roman pottery was recovered from fill 14209.
- 4.5.8 The two ditches both correlate with the linear cropmarks, but the discrete feature also targeted by the trench was not identified.
- 4.5.9 **Trench 143** was located nearly 15m to the north-east of Trench 142. Numerous ditches were revealed, including a recut boundary (14312) towards the western end that is likely to have been the continuation of ditch 14115 in Trench 141 and its later recuts. Ditch 14312 is most likely to have been the same feature as ditch 14115. It was the earliest and largest in the sequence, measuring 2m wide and at least 0.5m deep. Its earliest fill (14313) was a naturally silted deposit that produced a small quantity of middle Roman pottery. It was overlain by a sterile deposit of stony silt (14314). The western edge of the ditch was then recut by the much smaller

ditch 14303, which measured 0.68m wide and 0.3m deep with a single fill (14304). This was in turn truncated to the east by ditch 14305, which had a similar profile but was slightly larger, being 0.92m wide and 0.4m deep. It contained a primary deposit of grey-brown sandy silt (14306), overlain by a dark brown sandy silt deposit (14307) which produced a small quantity of Roman pottery and two degraded fragments of possible rotary quern. The final feature in the sequence was a small pit (14315), which had a shallow concave profile, truncating the edge of ditch 14305. It contained a single sterile fill and no finds.

- 4.5.10 Ditch 14320 was orientated N–S and located immediately to the east of ditch 14312. It had steep sides, measured 1.6m wide and was excavated to a depth of 0.45m but was not bottomed. It was filled by a process of natural silting with two deposits (14321 and 14322). No artefacts were recovered from this feature.
- 4.5.11 Ditch 14309 was situated on a perpendicular alignment to ditch 14320. It measured 0.85m wide with moderately steep sides and a concave base and was 0.3m deep (Plate 4). It was filled by a grey sandy silt deposit (14310), overlain by a thin deposit of brown sandy silt (14311). Both deposits were formed by gradual silting. Only fill 14310 contained any artefactual material, comprising a single piece of well-preserved animal bone (mole), which may have been intrusive. Bulk soil sample 9 was collected from fill 14310 and produced a small quantity of charcoal and a moderate assemblage of terrestrial mollusc shells.
- 4.5.12 The eastern end of ditch 14309 met with a group of intercutting pits (14317, 14318 and 14319). These features were recorded in plan only, but it is interesting to note that they coincide with a N–S aligned linear cropmark and although these appeared to be a cluster of pits, they may be concealing a linear feature.
- 4.5.13 **Trench 144** was positioned 18m south of Trench 143. It revealed a single linear ditch (14406), which had a shallow concave profile, 1.66m wide and 0.24m deep, with a single fill light brown silty sand (14407). It produced four sherds of Roman pottery. Two cropmark features has been plotted in tis location and it is uncertain which one ditch 14406 represents.
- 4.5.14 Several other features were investigated in the trench but were interpreted as natural features (14403, 14404 and 14405).
- 4.5.15 **Trench 145** was located approximately 20m east of Trenches 143 and 144. It revealed several linear and discrete features. Ditch 14513 was located near the northern end of the trench. It was 1.2m wide and 0.4m deep, with a single fill (14514). Ditch 14502 was located approximately 3.5m to the south on a broadly parallel, E–W alignment. It was filled by a sequence of three deposits. The primary fill was gravelly deposit 14503, overlain by naturally silted deposits 14504 and 14505. All three fills were tipping in from the northern edge, suggesting a bank on this side. No finds were recovered from this ditch.
- 4.5.16 Ditch 14510 was orientated NE–SW and matches the position of a linear cropmark recorded to the south-west as ditch 14708 in Trench 147. In Trench 145 it had a shallow concave base and was 0.62m wide and 0.32m

deep. At the base of the ditch was a thin primary deposit of sandy gravel (14511), which was overlain by a deposit of brownish grey sandy silt (14512). The later deposit produced three small pieces of middle Roman pottery.

- 4.5.17 Pit 14506 was irregular in plan with a concave profile and was 0.3m deep. It contained a sterile deposit of light grey silty sand. It was truncated to the east by pit 14508. This later feature was smaller, 0.6m in diameter and just 0.16m deep. It contained a similar sterile fill with no finds.
- 4.5.18 Pit 14515 was located at the southern end of the trench. It was sub-circular in plan with a diameter of 0.62m and steep sides leading to a slightly concave base, 0.38m deep. It contained a deposit of greyish brown, sandy silt but no artefacts were recovered.
- 4.5.19 Pits 14517 and 14518 were also identified but were only recorded in plan.

## 4.6 Trenches 134-7 and 139-40 (Figs 9 and 10)

- 4.6.1 This group of trenches were located to the west of Hornsby Lane and targeted the northern limit of the cropmark complex that extends across Land Parcel 3 (North).
- 4.6.2 **Trench 140** was located at the south of the group, approximately 30m north of Trench 145. At the eastern end of the trench was N–S aligned ditch 14007. It had gently sloping sides, leading into a pronounced concave base at the centre of the ditch, and measured 1.7m wide and 0.32m deep. It was filled by a deposit of brown sandy silt (14008) from which middle Roman pottery was recovered.
- 4.6.3 Ditch 14002 was recorded near the centre of the trench. It had an irregular profile with splayed upper edges, becoming very steep towards the broad, slightly concave base (Plate 5). Overall, it measured a little more than 3m wide and 0.6m deep. It contained two thin primary deposits on the eastern side of the ditch (14003 and 14004). These were overlain by deposit 14005, a brown sandy silt containing residual prehistoric and early/middle Roman pottery and an upper fill (14006) comprising dark brown sandy silt, which also produced some pottery. It corresponded with a NW–SE aligned cropmark and is the same feature as ditch 13902 in Trench 139. Although the recorded alignment of ditch 14002 does not suggest a connection with ditch 13902 it is possible that it was more obliquely orientated than realised at the time of excavation, which might also explain the unusual profile and substantial width.
- 4.6.4 **Trench 139** was situated to the north-west of Trench 140. It exposed a single ditch (13902). Orientated on a NW–SE alignment and matching the cropmark associated with ditch 14002, it appears to be a continuation of the same ditch. It measured 2m wide with steep sides and a concave base and was 0.66m deep. The primary fill (13903) comprised light grey silty sand and produced a combination of residual early Roman pottery, iron fragments and a worn copper alloy coin dating to AD 260–96. This was overlain by upper fill 13904, a deposit of grey-brown, silty clay which also contained fragments of residual late Iron Age/early Roman pottery.

- 4.6.5 **Trench 137** was located approximately 15m north of Trench 139. It revealed E–W aligned ditch 13703, a shallow concave feature, 0.78m wide and 0.2m deep with a fill of grey-brown clay sand. Although slightly offset, this corresponded with a linear cropmark on the same alignment. A second cropmark was also targeted by this trench, to the north on a NE–SW alignment. A change in the natural was investigated that was thought to correspond to this cropmark, but no archaeological feature was identified.
- 4.6.6 **Trench 136** was excavated to the north of Trench 137 and also targeted on the NW–SE aligned cropmark. In this trench two separate ditches, 13603 and 13605, were recorded on the same alignment as the cropmark. Ditch 13603 measured 0.68m wide and 0.16m deep and was filled with a deposit of sterile grey-brown sandy silt. Ditch 13605 as less than 1m to the south-east and slightly larger at 1.3m wide and 0.36m deep, but contained a similar fill to the adjacent ditch, also devoid of finds.
- 4.6.7 A cluster of three unurned cremation burials (13609, 13610 and 13613) were recorded to the north-west of the two ditches (Plate 6). They varied in size and form. No artefacts were recovered from any of the pits, other than cremated bone fragments. Pit 13609 was noted to have signs of heat-affected soil on its southern edge indicating the material was dumped relatively rapidly after collection. Bulk soil samples 4–7 were collected from cremation burial 13610 and yielded large quantities of charcoal and a single charred wheat grain fragment, as well as burnt bone and flint. Eight soil samples (8, 11, 12, 15, 18, 20, 21, 24) were collected from cremation burial 13609, from which large quantities of charcoal were identified, alongside a few charred weed seeds and small quantities of burnt bone and flint. Six samples (10, 13, 16, 17, 19, 23) were collected from cremation burial 13613 and also contained large quantities of charcoal and small amounts of burnt bone and flint. A detailed report on the cremated human bone is provided in Appendix C.
- 4.6.8 **Trenches 134 and 135** were positioned to the north-east of Trench 136 and were both targeted on the same linear cropmark. Ditches 13402 and 13502 appear to be part of the same feature from which the cropmark was derived. Orientated NE–SW, they had moderately steep sides and a concave base up to 1.6m wide and 0.7m deep (Plate 7). In both trenches the ditch was filled by a sequence of three fills. No finds were recovered from the fills of ditch 13502, but ditch 13402 contained fragments of post-medieval/modern glass and iron objects.
- 4.6.9 Ditch 13402 was recut by a smaller ditch on the same alignment (13405). It contained a single fill and no finds.

## 4.7 Trenches 120-2 (Figs 11 and 13)

- 4.7.1 Trenches 120, 121 and 122 were located in the north-west corner of the parcel and positioned to investigate an area without any cropmarks.
- 4.7.2 **Trenches 120 and 122** were located to the west and east of Trench 121, respectively. They both revealed what appears to be the same ditch, orientated ESE–ENE. Ditch 12002 in Trench 120 measured 1.24m wide and 0.52m deep and was filled with a sequence of five naturally silted deposits. Ditch 12202 was recorded just over 61m to the north-east on the

same orientation but was slightly different in appearance. It measured 1.36m wide and 0.3m deep with two naturally accumulated deposits. Post-medieval/modern CBM, glass and animal bone were recovered from ditch 12202.

- 4.7.3 **Trench 121** was located in the middle of the three trenches and revealed a single small pit (12102). Circular in plan with a shallow concave base, this small pit contained a single sterile fill. Without any dating evidence and seemingly isolated from other similar features, its date and function are uncertain.

## 4.8 Trenches 156, 165 and 192 (Figs 12 and 13)

- 4.8.1 **Trenches 156 and 165** were both located in the narrow, central strip of Land Parcel 3 (North). Trench 156 revealed small undated pit 15602 and Trench 165 contained a NNE–WSW aligned ditch, 16501. No finds were recovered from either feature, and there is no correlation between these and other features or cropmarks.
- 4.8.2 **Trench 192** was positioned 130m north of Trench 165, to the south of Stanford Road. At the western end of the trench was NNW–ESE aligned ditch 19202. It had an irregular shape and contained loose silty sand deposit with pottery, glass and some iron objects, all of 19th-/20th-century date. Based on the artefacts from this ditch, it is likely to be a field boundary mapped on the 1st edition OS map at this location.

## 4.9 Trenches 172-4 and 176 (Figs 14 and 15)

- 4.9.1 This group of trenches were located in the east of the site in a narrow strip that extended to the south from the east end of the Land Parcel.
- 4.9.2 **Trench 172** was situated at the north-east of the group, against the eastern boundary of the site. At its southern end it revealed NE–SW aligned ditch 17208. It has steep sides and a shallow, broad base and was 2.2m wide and 0.4m deep. It was filled with a deposit of dark grey-brown, silty sand, (17209) which produced CBM and metalwork of post-medieval date.
- 4.9.3 Ditch 17206 was located near the centre of the trench on a broadly parallel alignment to ditch 17208. It was 1.38m wide and 0.34m deep with a broad concave profile. It contained a fill of grey-brown silt sand (17207). No finds were recovered.
- 4.9.4 A third parallel ditch was recorded near the northern end of the trench. Ditch 17202 also had a broad slightly concave profile, measuring 2.1m wide and 0.4m deep. It was filled with a deposit of grey-brown silty sand but produced no dating evidence. However, it was recut as ditch 17204 along its centre line. Ditch 17204 contained a similar, slightly darker fill (17205), which produced several sherds of middle Roman pottery and two fragments of animal bone.
- 4.9.5 Ditches 17202, 17204 and 17206 all matched linear cropmark features at their locations. Although almost identical in appearance, ditch 17208 had no corresponding cropmark.
- 4.9.6 Between ditches 17202 and 17206 were two small pits or postholes (17210 and 17211), which were recorded in plan but not excavated.

- 4.9.7 **Trench 173** was positioned immediately to the south-west of Trench 172, at the possible convergence of five different linear cropmarks. Unfortunately, due to its location at the start of a dry valley that descended to the south-west, only a colluvial layer (17302) was observed at the base of the trench after excavation to a depth of 1m. No features were identifiable.
- 4.9.8 **Trench 174** was located to the south of Trenches 172 and 173. It revealed a single ENE–WSW aligned ditch (17402), which was 1m wide and 0.16m deep with a single fill of silty sand but no associated artefacts. At the south-west end of the trench was a second possible ditch (17404), but this was recorded in plan only.
- 4.9.9 **Trench 176** was situated at the south end of the group, approximately 70m south of Trench 174. A single ditch (17603) was recorded at the northern end. It was broadly aligned E–W, with a slightly irregular shape in plan and an irregular concave profile. It measured 1.54m wide and 0.14m deep. It was filled with a deposit comprising dark brown sandy silt (17604) and contained ten sherds of middle Bronze Age to Iron Age pottery and some burnt stone.

#### 4.10 Trenches 169-70, 177, 179 and 183-4 (Figs 16 and 17)

- 4.10.1 This group of trenches were located in the north-east part of Land Parcel 3 (North). Few cropmark features were mapped at this location, so these trenches were distributed to provide an even coverage and test the blank areas. This location is particularly interesting as it provides a remarkable viewpoint across the landscape to the west, south and south-east.
- 4.10.2 **Trenches 169, 170 and 184** were distributed along the western edge of the group and exposed a single linear ditch orientated NNW–SSE that ran through all three trenches (17003, 16902 and 18402). The ditch had moderately steep sides and a concave base and measured between 1.25m and 1.42m wide and up to 0.38m deep. In Trenches 170 and 169 it was filled by a single deposit of grey-brown sandy silt. In Trench 184 the fill sequence was divided between primary silting episode 18403 and upper naturally silted deposit 18404. Across the three interventions excavated, only deposit 18403 produced any finds, comprising late Bronze Age/Iron Age pottery and a piece of perforated fired clay slab/plate of late Bronze Age date.
- 4.10.3 The alignment of this ditch beyond the three trenches is not known, as it was not identified as a cropmark feature and did not appear in the adjacent trenches.
- 4.10.4 **Trench 183** was positioned 25m north-east of Trench 184. At the north-east end of the trench was a wide, shallow linear feature (18309), which was only partially exposed within the trench. It measured at least 1.75m wide and 0.18m deep with a flattish undulating base. It had been filled by a single deposit of grey-brown sandy silt (18310) which produced a sherd of pottery. The feature may be the remnant of a footpath between Heath Place and Prattocks farms that is mapped on the 1st edition OS map.

- 4.10.5 A small pit or posthole (18305) was recorded to the west of feature 18309. It had steep sides and was 0.26m in diameter with a flat, narrow base, and was 0.15m deep with a single fill of sandy silt.
- 4.10.6 Feature 18302 was situated approximately 4m to the west. It measured 0.45m wide and up to 0.7m deep. It was filled by brown-grey sandy silt deposit 18303, which produced a sherd of Roman pottery. The feature was only partially observed as it extended beyond the north-west edge of the trench and had been truncated by ditch 18304. It is uncertain if this was an earlier ditch terminus or in fact a pit. Ditch 18304 had a steep-sided concave profile 1.5m wide and 0.5m deep. It was filled by an initial slump of material (18306), which was overlain by a slower accumulation of sandy fill (18307). No finds were recovered from this ditch.
- 4.10.7 **Trench 177** was positioned to the south-east of Trench 183. It revealed single ditch 17702, which appeared to be the continuation of ditch 18304 in Trench 183. It was slightly shallower at this location than in Trench 183 and was filled by a single deposit of dark brown silty sand (17703). It also corresponded with a linear cropmark on the same alignment, although the cropmark does not extend much further north-west of Trench 177. No finds were recovered.
- 4.10.8 **Trench 179** was positioned in the south-east corner of this group, a little more than 40m east of Trench 177. It revealed two small ditches on perpendicular alignments at its western end. Ditch 17902 had moderately steep sides and a concave base and was 0.6m wide and 0.26m deep. It was filled by a natural silting deposit (17903) and incorporated finds of pottery and slag. The adjacent ditch 17904 was not excavated but was almost identical in appearance.

## 4.11 Trenches 186-9 (Figs 18 and 19)

- 4.11.1 This group of trenches were also located in the north-east corner of the site, on the higher ground adjacent to the Stanford Road. Their positions were evenly distributed as no cropmarks were mapped in this location.
- 4.11.2 **Trench 186** was located to the north-west of Trench 183. At the northern end of the trench was NE–SW aligned ditch 18606 (Plate 8). One of the largest features encountered in this part of the site, it had steep convex sides 2m wide and measured at least 1m deep but was not fully excavated. It contained a single fill (18607), which produced medieval/early post-medieval CBM and a fragment of animal bone.
- 4.11.3 Ditch 18602 was located 4.5m to the south-east on a parallel alignment. It had a broad concave profile and was 1.2m wide and just 0.22m deep, with a single sterile fill of silty sand. This was almost identical to a third, broadly parallel ditch at the southern end of the trench (18604).
- 4.11.4 **Trench 187** was positioned to the east of Trench 186. It revealed single NW–SE aligned ditch 18702, with a similar shallow concave profile and single fill to ditches 18602 and 18604. Situated on a perpendicular alignment, they are likely to have formed part of a broader field system. No dating evidence was recovered from this ditch.



- 4.11.5 **Trench 188** revealed two shallow pits (18802 and 18804). They both contained dark sandy silt deposits but produced no finds and appear to have been heavily truncated. The largest of the two, 18804, measured just 0.13m deep.
- 4.11.6 **Trench 189** was located more than 40m north-west of Trenches 188 and 187. Ditch 18903 was recorded at the north-east end of the trench on a NW–SE orientation. It had a similar profile and fill to the shallow concave ditches recorded to the south in Trenches 187 and 186 and was broadly aligned with ditch 18702. Although it is difficult to be certain this was the same feature over this distance, they may have been part of the same field system. As with the other examples no finds were recovered from ditch 18903.
- 4.11.7 Adjacent to the east of ditch 18903 were pits 18905 and 18907. They were both sub-circular in plan with steep sides and concave bases and were filled by a deposit of dark grey-brown silty sand. No artefacts were recovered from either pit.

## 4.12 Trenches 40, 42-4, 46-8 and 51 (Figs 20 and 21)

- 4.12.1 This group of trenches are part of Land Parcel 30, located on the northern side of Stanford Road. They were positioned towards the north-west corner of the site, close to the A13. None of the trenches in this group was placed to target a known cropmark.
- 4.12.2 **Trench 40** was located at the north of the group, immediately north of Trench 44. It revealed two pits (4002 and 4004). Pit 4002 was circular in plan, 0.8m in diameter and 0.22m deep. It was filled with a greyish brown sandy clay deposit with a spread of charcoal at its surface.
- 4.12.3 Pit 4004 was more irregular in plan and extended beyond the southern edge of the excavated area. It was filled with a deposit of grey-orange sandy clay, not too dissimilar to the surrounding geology. The overall appearance of the feature is that of a geological variation, but two flints were recovered from the surface interface between the fill (4006) and subsoil (4005).
- 4.12.4 **Trench 42** was positioned more than 60m south-west of Trench 40. It revealed two pits (4203 and 4205) and a possible third pit or ditch terminus (4207). Pits 4203 and 4205 both contained grey-brown silty clay fills. A fragment of middle Bronze Age to Iron Age pottery was recovered from the fill (4206) of pit 4205.
- 4.12.5 Pit/ditch terminus 4207 was almost 1m wide and 0.31m deep. It was filled by a primary silting episode (4209), which was overlain by a natural accumulation of brownish grey silty sand (4208) which incorporated 13th- to 15th-century pottery and animal bone fragments. The final fill was a deposit of yellowish grey sandy silt (4210).
- 4.12.6 **Trench 43** was situated east of Trench 42. Located near the centre of the trench was N–S aligned ditch 4311. It measured 0.8m wide and 0.22m with moderately sloped sides and a concave base. It contained a single deposit of grey-brown silty clay (4312), which produced fragments of animal bone but no dating evidence.

- 4.12.7 To the west of the ditch was a short, ENE–WSW alignment of five shallow postholes (4303, 4305, 4307, 4309 and 4313; Plate 9). Sub-circular in plan, they were all less than 0.1m deep and had shallow gently sloped profiles. Each filled with a deposit of grey-brown silty clay. None of the postholes yielded any artefacts.
- 4.12.8 **Trench 44** was located east of Trench 43 and revealed the remains of possible ditch terminus 4405. It was orientated NW–SE and extended to the south-east beyond the limits of the trench. It had a concave profile and was 0.55m wide and 0.22m deep with a single naturally silted fill of brownish grey clay silt (4406). Middle Bronze Age to Iron Age pottery and prehistoric flint were recovered from the feature.
- 4.12.9 **Trench 46** was positioned to the south of Trench 42. It revealed two parallel ditches spaced almost 15m apart on NNW–ESE alignments. Ditches 4605 and 4603 had broadly identical concave profiles of similar dimensions and were filled with deposit of brownish grey clay silt. However, deposit 4606, the fill of ditch 4605, was rich in charcoal, indicating a dump of burnt material. Bulk soil sample 26, collected from deposit 4606, yielded a large quantity of charcoal and charred cereal grains of wheat and oat, as well as a few weed seeds. Prehistoric worked flint was recovered from ditch 4605. It is possible that the two ditches were broadly contemporary in date.
- 4.12.10 Pit 4607 was located in the western part of the trench and contained a sterile deposit of dark grey-brown, clay silt (4608).
- 4.12.11 **Trench 47** was located to the east of Trench 46 and revealed two ditches. Ditch 4704 was aligned WNW–ESE and had a wide, shallow profile 1.1m across and 0.23m deep. It was filled with a single, sterile clay silt deposit (4705). Ditch 4706 was recorded immediately to the north of 4704 on a WSW–ENE alignment with the ditches converging at the western bank of the trench. No relationship was recorded between the ditches, which were nearly identical in appearance, and neither feature produced any finds. Ditch 4704 corresponds with a historic field boundary mapped on the 1st edition OS map.
- 4.12.12 **Trench 48** was situated east of Trench 47 and south of Trench 44. A single oval pit (4804) was observed at the western end of the trench. It contained a single naturally accumulated fill of silty clay and contained no finds. In the remainder of the trench several other possible pits were also investigated but were all determined to be of natural origin (4802, 4803, 4806, 4807).
- 4.12.13 **Trench 51** was situated immediately south of Trench 47. Ditch 5104 was recorded at the western end of the trench and extended on a NNW–SSE alignment. It measured just 0.56m wide and 0.1m deep, with a single fill of sterile sandy silt.
- 4.12.14 Ditch 5103 was recorded in plan at the east end of the trench on a parallel alignment to 5104. It corresponded with a mapped historic boundary and is likely to be a continuation of ditch 4704 in Trench 47.

## 4.13 Trenches 55-5, 58 and 61-3 (Figs 22 and 23)

- 4.13.1 This group of trenches were positioned in the south-west corner of Land Parcel 30, just north of Stanford Road. It includes Trenches 61 and 62,

which were targeted on a large annular cropmark which was the only cropmark identified in this part of the site.

- 4.13.2 **Trench 55** was located in the north-west corner of the group, north of Trench 60 and west of Trench 56. It revealed a single linear feature aligned NNW–SSE (5503). Like so many of the ditches in this part of the site, ditch 5503 had a shallow concave profile and was just 0.41m wide and 0.11m deep. It was filled with a sterile deposit of light grey sandy silt.
- 4.13.3 **Trench 56** was excavated to the east of Trench 55. At the southern end of the trench was NE–SW aligned ditch 5603. It measured 0.96m wide and 0.3m, with steep sides and a rounded base containing a naturally silted clay silt deposit. At its south-west end, the ditch met NNW–SSE aligned linear feature 5607. It is possible that 5607 is the continuation of ditch 5104 based on their common alignment.
- 4.13.4 **Trench 58** was situated 80m east of Trench 56. It revealed NE–SW aligned ditch 5803. The ditch had steep sides and a flattish base and was 0.84m wide and 0.28m deep. It was filled with a sterile, grey-brown clay silt deposit (5804).
- 4.13.5 Several possible features to the north of the ditch were investigated and determined to be of natural origin (5805, 5806).
- 4.13.6 **Trench 61** was located south of Trench 56, close to Stanford Road. It was targeted on an annular cropmark feature approximately 20m in diameter. A little more than 5m from the north-east end of the trench a very shallow cut (6103) was observed in section, measuring almost 1.9m wide and just 0.12m deep. During cleaning, several small sherds of possible early Neolithic pottery were recovered from its fill (6104).
- 4.13.7 Ditch 6109 was located almost 9m south-west of ditch 6103. Broadly aligned N–S, it had a shallow concave profile, filled with a sterile deposit of light grey sandy silt (6110).
- 4.13.8 Ditch 6107 lay parallel to ditch 6109, some 2.2m further south-west. It was slightly larger, with steep sides and a concave base and was 0.81m wide 0.21m deep. Its fill (6108) produced a worked flint.
- 4.13.9 Pit 6114 was recorded in plan at the south-west end of the trench and extended beyond the excavated area. Other possible features were also investigated but determined to be of natural origin (6105, 6111, 6112, 6115).
- 4.13.10 **Trench 62** was situated adjacent to Trench 61 and was targeted on the north-east side of the annular cropmark. As in Trench 61, a shallow feature was observable in section. Approximately 4m from the south-west end of the trench, the ditch was approximately 2.5m wide and 0.08m deep and contained a single fill of greyish brown clay silt (6209).
- 4.13.11 At the north-east end of the trench was NNW–SSE aligned ditch 6203. The ditch corresponded with the same historic field boundary as ditches 5103 and 4704. Its upper fill (6205) produced burnt stone and fragments of glass of 19th-/20th-century date. It truncated a small undated pit (6206) on its eastern side.

4.13.12 **Trench 63** was positioned to the east of Trench 62 and revealed a single small pit (6303). The pit measured 0.53m in diameter and 0.19m deep and had been backfilled with a dump of clay silt containing large amounts of burnt clay (6304), but no dating evidence.

#### 4.14 Trenches 66, 69, 70 and 72-5 (Figs 24 and 25)

4.14.1 This group of trenches were positioned further to the east and closer to the A13. Several of the trenches were targeted on a group of three parallel linear cropmarks and several large discrete features.

4.14.2 **Trench 66** was located to the north-west of the group and targeted the easternmost of the three linear cropmarks (6604). The ditch had a shallow concave cut and was filled by a single deposit of greyish brown clay sand (6605).

4.14.3 A second ditch (6602) was recorded to the east on a NW–SE orientation. It was steep sided and measured 0.82m wide and 0.24m deep. The primary fill was a silty gravel deposit (6606) and was overlain by a fill (6603) comprising stony clay sand.

4.14.4 **Trench 69** was positioned south-west of Trench 66 and targeted the other two linear cropmarks. However, the only feature was a single sub-rectangular pit (6903) at the north-east end of the trench. Pit 6903 contained a fill of greyish brown clay sand (6904), which produced a single flint flake.

4.14.5 **Trench 70** lay immediately to the east of Trench 69 and also revealed just a single isolated pit (7005) filled with naturally silted deposit of silty clay. No dating evidence was recovered from this feature. Several other possible pits were also investigated but were not thought to be of archaeological origin (7003, 7004, 7007, 7008).

4.14.6 **Trench 72** was targeted on a cluster of discrete cropmark features to the south of Trench 69. At the south-west end it revealed a small sub-circular undated pit (7203). To the west of this, coinciding with one of the cropmarks, was larger pit 7207. Pit 7207 was irregular in shape and measured at least 1.48m long and 0.9m wide. The base of the pit was not exposed due to its depth, but it was more than 0.42 deep. It contained a sequence of four naturally silted deposits, none of which contained any finds.

4.14.7 Pit 7207 was cut by ditch 7205, which extended on a broadly E–W alignment with a slightly sinuous shape in plan. It had moderately steep sides and a rounded base with a single fill comprising orange-brown sandy silt (7206). A small quantity of very abraded pottery of either early Neolithic or middle Bronze Age to Iron Age date was recovered from this deposit, together with a single fragment of animal bone. Based on the projected alignment of this ditch, it is possible that it is the same feature as 4405 in Trench 44.

4.14.8 **Trench 73** was located south of Trench 72. Near the north-west end of the trench was a concentration of features corresponded with the location of one of the many discrete cropmarks in this Land Parcel. The earliest feature in this sequence was ditch 7305. It was orientated broadly N–S with steep sides and a flat base and was 0.44m wide and 0.29m deep. It contained a

naturally silted fill (7306). It was recut along its eastern edge by ditch 7307. This later feature had a broader and shallow profile and was 2.22m wide and 0.25m deep and had also silted up through natural processes. No finds were recovered from this feature. A steep-sided small pit or posthole (7309) was recorded cutting through ditch 7307. This feature was only observed in section and continued beyond the excavated area. A second larger pit (7303) cut the north-west edge of ditch 7305. Pit 7303 was filled with a dark grey-brown silty clay (7304) but contained no dating evidence.

- 4.14.9 Ditch 7311 was located to the south-east and corresponded with a linear cropmark feature on a NNW–SSE alignment. Excavation of the feature revealed a ditch terminus with a single naturally silted fill (7312) from which a single sherd of early Roman (AD 1–150) pottery was recovered.
- 4.14.10 **Trenches 74 and 75** were positioned to the north-east of Trench 73. They revealed three similar pits (7403, 7503 and 7505). The only find recovered from the features was a flint flake from fill 7506 of pit 7505. Although their function is unclear, it is possible they had a similar purpose and date.

#### **4.15 Trenches 68, 71, 76, 82, 89, and 90 (Figs 26 and 27)**

- 4.15.1 This group of trenches were located near the centre of the site, close to the A13.
- 4.15.2 **Trench 68** revealed NNW–SSE aligned ditch 6802. This feature is positioned in the same location and orientation as a historic field boundary mapped on the 1st edition OS map. The dark grey silt upper fill produced an iron object of post-medieval/modern date, confirming that this was a relatively modern boundary ditch.
- 4.15.3 **Trench 71** was located to the south-west of Trench 68. It was targeted on a large discrete cropmark which appears to have been caused by pit 7103. Extending beyond the limits of the excavation the pit measured at least 2.22m in diameter and 0.42m deep. It was filled with a grey-brown silty sand deposit (7102), which produced small fragments of abraded possible Iron Age pottery and prehistoric worked flint.
- 4.15.4 **Trench 76** also revealed a large pit (7603), located just over 22m to the south-east of 7103. Pit 7603 measured 2.2m long, at least 1.65m wide and in excess of 0.5m deep, although the base was not reached during excavation (Plate 10). It contained a dump of charcoal rich material (7604), which had been introduced from the southern edge. This was then sealed by deposit greyish yellow sand (7605) which appears to have accumulated naturally. Fill 7604 contained seven sherds of Anglo-Saxon pottery dating to c 400–750, together with residual prehistoric worked flint and Roman pottery. Fill 7605 produced further fragments of residual Roman pottery and prehistoric flints. Bulk soil sample 25, collected from fill 7604, contained a large quantity of charcoal and smaller amounts of charred cereal grains (barley and possible wheat) and weed seeds.
- 4.15.5 The central upper portion of the pit appeared to have been truncated by later feature 7615. Pit 7615 was ovoid in plan and just 0.24m deep with a concave longitudinal profile. Its fill (7606) comprised a greyish yellow silty sand and also incorporated charcoal flecks towards the base, which had

presumably derived from the truncation of deposit 7404. It also contained sherds of residual Roman pottery and Roman CBM fragments.

- 4.15.6 At the northern end of the trench were two narrow ditches (7608 and 7610). They were broadly parallel to each other and less than 0.1m apart, on ENE–WSW alignments. Both ditches had shallow concave profiles less than 0.14m deep and were filled with greyish brown silty sand deposits without finds. A small undated pit or posthole (7612) was recorded in the space between the two in the north-east corner of the trench.
- 4.15.7 **Trench 82** was positioned near the northern edge of the site and exposed pit or large posthole 8202. It had steep sides and a rounded base and was 0.58m in diameter and 0.38m deep. Filling the pit were two sandy clay deposits (8204 and 8205). The surface of the feature was truncated by a small shallow cut 8206. No finds were recovered from either feature.
- 4.15.8 **Trench 89** revealed just a small portion of a feature at its south-west end. Only partially exposed and not relating to any cropmarks, it remains unclear whether 8902 was part of a ditch or another large pit. Medieval pottery dating to the 11th to early 13th century was recovered from its single fill (8903), alongside residual early/middle Roman pottery and Roman CBM. A fragment of whetstone was also recovered from the surface of this feature.
- 4.15.9 **Trench 90** was located east of Trench 89. It revealed a single ENE–WSW aligned ditch (9002). It measured almost 1.5m wide and just 0.13m deep with a sterile fill of dark grey-brown silty clay. No adjacent trenches revealed similar features on this alignment and there is no corresponding cropmark.

## 4.16 Trenches 78, 105-6 and 112-14 (Figs 28 and 29)

- 4.16.1 This group of trenches were positioned near the middle of the site, close to Stanford Road and opposite Whitecroft's Farm. The cropmarks for this area of the site indicated numerous discrete features and a linear feature that probably corresponds to a historic field boundary.
- 4.16.2 **Trench 78** was located approximately 20m south of Trench 75. Towards the northern end of the trench was large WNW–ESE aligned ditch 7802. It had moderately steep sides and a flattish base and was 1.9m wide and 0.45m deep. It contained a primary slump of material (7808), comprising light grey silty clay, overlain by an orange-brown silty clay (7809). The final upper fill was a deposit of greyish brown silty clay (7803) and produced a small quantity of Roman pottery. The deposits reflect a process of gradual natural silting.
- 4.16.3 Truncating the southern edge of the ditch was pit 7804. This feature was particularly difficult to see but consisted of a slightly irregular cut filled with a slump deposit of gravelly clay (7810), overlain by a sterile deposit of greyish brown silty clay (7805).
- 4.16.4 Near the southern end of the trench was unusual, narrow linear feature 7806. Initially interpreted as a ditch, this is perhaps more likely to be a result of bioturbation.
- 4.16.5 An area of greyish brown silty clay was investigated at the northern end of the trench and interpreted as a patch of natural silting (7811). It corresponds with a discrete cropmark but in the absence of any archaeological material

to suggest otherwise, it is believed that the cropmark is derived from a geological variation.

- 4.16.6 **Trench 105** was located to the east of Trench 78. It revealed NNW–SSE aligned ditch 10502. The position and orientation of this ditch matches both a linear cropmark and a field boundary recorded on the 1st edition OS map. Recovery of iron objects and CBM confirm a post-medieval/modern date for this ditch.
- 4.16.7 **Trench 112** was positioned to the south of Trench 105 and located the same cropmark field boundary (11202). A small quantity of Roman pottery was recovered from its single fill (11203). At the southern end of the trench this was truncated by perpendicular ditch 11206. Ditch 11206 contained a single fill (11207), which produced Roman pottery and the remains of a near complete calf skeleton. Due to the level of preservation, it is likely that the pottery is residual and the faunal remains are more recent than the Roman period.
- 4.16.8 In the northern half of the trench was L-shaped ditch 11204. It had a shallow concave profile and was 1.17m wide and 0.16m deep with a fill of brownish grey clay silt (11205). No finds were recovered from this ditch and no clear relationship with 11202 could be established.
- 4.16.9 **Trench 106** was located a little more than 25m to the north-east of Trench 112. At the eastern end of the trench an irregular, curvilinear feature was excavated in two places (10604 and 10602). It was a shallow, steep-sided feature with a wide flattish base, up to 0.74m wide and 0.27m deep. The fill was a grey-brown silty clay deposit (10605) that contained a sherd of middle Bronze Age to Iron Age pottery. The unusual form of the feature made it difficult to determine its original function. It was perhaps a tree-throw hole but could be part of an irregular, truncated curvilinear ditch.
- 4.16.10 **Trench 113** revealed a pair of small intercutting pits (11302 and 11305). Pit 11302 contained two fills (11303 and 11304). Upper fill 11304 was a dark grey-brown silty clay, with frequent fragments of charcoal and a large stone, suggesting this was a deliberate dumped deposit, though it did not produce any finds. Soil sample 3, collected from fill 11303, produced just a small amount of charcoal. The pit was truncated to the east by pit 11305, which contained a single undated fill (11306).
- 4.16.11 **Trench 114** was located to the east of Trench 113 and adjacent to a row of houses referred to as Five Chimneys on historic mapping. At the northern end of the trench was undated ditch 11402, orientated ENE–WSW, which contained only a few pieces of animal bone. To the south was a second ditch (11404). It measured 1.7m wide and 0.31m deep with gently sloped sides and a flat base. It contained a grey-brown, silty clay fill (11405) which produced a piece of animal bone.
- 4.16.12 Ditch 11404 coincides with the northern end of a structure mapped on the 1st edition OS map that was no longer extant on the site. Although no structural material was recovered from the ditch, it is possible that this was a robber trench to remove the foundations of the structure.

## 4.17 Trenches 98-100 and 108 (Figs 30 and 31)

- 4.17.1 This group of trenches were situated to the north of the Five Chimneys residential dwellings.
- 4.17.2 **Trench 98** was located at the west of the group. In the south-east end of the trench was possible ditch terminus or pit 9802. It measured 0.88m wide and 0.24m deep with a fill of orange-brown sandy clay which produced a single flint flake.
- 4.17.3 Near the centre of the trench were two adjacent pits or perhaps two ditch terminals forming an entrance (9804 and 9806; Plate 11). They were very similar in appearance with steep sides and slightly concave bases, approximately 1m wide and 0.3m and 0.42m deep. Both features were filled by deposits of greyish brown sandy clay (9805 and 9807). Pit 9804 also contained fragments of middle Bronze Age to Iron Age pottery and prehistoric worked flint, and pit 9806 produced prehistoric worked flint.
- 4.17.4 **Trench 99** was located to the east of Trench 98 and revealed a single undated posthole (9902) at the southern end of the excavated area as well as a natural feature (9904).
- 4.17.5 **Trenches 100 and 108** were situated to the east of Trench 99 and both revealed what is believed to be the same slightly sinuous NW–SE aligned ditch (10003 and 10802). Deposit 10004 from ditch 10003 contained both prehistoric worked flint and middle Bronze Age to Iron Age pottery, but no finds were recovered from the feature in Trench 108. It had moderately steep sides and flattish base up to 0.77m wide and 0.3m deep. Due to its alignment, it was not identified in any adjacent trenches and does not correspond to any cropmark features plotted in this field.

## 4.18 Trenches 83-6 and 92-3 (Figs 32 and 33)

- 4.18.1 This group of trenches were positioned towards the north-east corner of Land Parcel 30, adjacent to the A13.
- 4.18.2 **Trench 83** was located to the west of this group. Ditch 8302 was recorded near the north-west end of the trench with a ENE–WSW alignment. It had a broad shallow profile, 2.1m wide and 0.3m deep, containing naturally accumulated fills 8303 and 8304. The upper fill (8304) produced two small sherds of Roman pottery. Ditch 8305 was located along the northern edge of ditch 8302, on a parallel alignment. Due to the similarity of their fills, no relationship could be determined. A tiny fragment of undated pottery was recovered from the fill of ditch 8305 (8306).
- 4.18.3 Elongated ovoid pit 8307 was excavated to the south of the ditches. Due to its irregular profile, it is more likely to be a tree-throw hole than an archaeological feature. No finds were retrieved from its fill.
- 4.18.4 **Trench 84** was excavated to the north-east of Trench 83. It revealed two ditches and a pit. Large NNW–SSE ditch 8406 measured 2.38m wide with steep sides leading to a broad concave base and was 0.7m deep (Plate 12). At the base of the ditch was a primary deposit of silty clay (8408) including flecks of fired clay, overlain by a naturally silted layer of silty clay (8407).



- 4.18.5 Located several metres to the east was a second ditch on a parallel alignment (8404). It was 0.64m wide with a shallow undulated base 0.07m deep. It was filled with a deposit of orange-brown silty clay but contained no artefacts.
- 4.18.6 Pit 8402 was situated immediately to the east of ditch 8404. The shape in plan and profile were both slightly irregular and it measured 1.92m wide and 0.52m deep. It was filled with a deposit of grey-brown silty clay (8403) and yielded a piece of worked flint.
- 4.18.7 **Trenches 85, 86 and 92** were adjacent to each other over a distance of approximately 100m near the northern edge of Land Parcel 30. They each appeared expose parts of the same NE–SW aligned ditch running across this part of the site (8502, 8602, 9202). It had a consistently shallow concave profile, between 0.56 and 0.73m wide and up to 0.22m deep. It was filled by a single naturally accumulated deposit that was devoid of finds.
- 4.18.8 In Trench 85, a small undated pit (8504) was excavated alongside the ditch.
- 4.18.9 **Trench 93** was positioned to the south of Trench 85. It revealed NNW–SSE aligned ditch 9307. It had steep sides and an undulating flattish base and was 1.85m wide and 0.4m deep. Filling the ditch was a single deposit of sandy clay (9308), which produced a small amount of Roman pottery.
- 4.18.10 Near the eastern end of the trench were two slightly irregular pits (9304 and 9302). Pit 9302 was almost 2m wide and 0.36m deep. It contained a fill of reddish-brown silty sand (9303) that was particularly difficult to differentiate from the geology. Several small sherds of middle Bronze Age to Iron Age pottery and a prehistoric worked flint were recovered from the fill. Pit 9304 was very similar in appearance, with two fills (9305 and 9306). No finds were recovered from pit 9304.

## 4.19 Trenches 88, 95-66, 102-4 and 111 (Figs 34 and 35)

- 4.19.1 This group of features were positioned at the eastern end of Land Parcel 30.
- 4.19.2 **Trench 88** was in the north-east corner of the site. Pit 8802 was only partially exposed, as it extended to the north beyond the limits of the trench. Ovoid in plan, it measured 1.14m wide and 0.45m deep. It contained a primary fill of brown clay silt (8804), overlain by a deposit of grey-brown clay silt (8803). Both fills produced finds of early Neolithic pottery and worked flint.
- 4.19.3 **Trench 95** was located approximately 20m south-west of Trench 88. It revealed a single undated ditch 9502. Orientated NNW–SSE, it was filled by a deposit comprising grey-brown silty clay (9503). It was not observed in any of the adjacent trenches.
- 4.19.4 **Trench 96** was located east of Trench 95. Ditch 9607 was recorded in the southern half of the trench on a WSW–ENE alignment. It had steep sides and an irregular base with a single fill of brown sandy silt (9608). A small amount of possible late Bronze Age/Iron Age pottery and prehistoric worked flint were recovered during excavation.

- 4.19.5 The large tree-throw hole (9609) to the north of ditch 9607 also contained a small amount of very abraded pottery of either early Neolithic or middle Bronze Age to Iron Age date from secondary fill 9610.
- 4.19.6 Several natural features were also observed and investigated in this trench (9605, 9606, 9612). It is unclear if undated possible pit 9603 was archaeological or natural in origin.
- 4.19.7 **Trench 102** revealed small irregular pit 10203 at its western end. It measured 0.9m in diameter and 0.18m deep with a rounded base. It contained an initial fill of yellow grey silt clay (10204) onto which a dump of burnt waste had been dumped (10205), rich in charcoal and with a large quantity of oxidised material. No dating evidence was hand collected from this pit; however, a very small and abraded sherd of possible Iron Age pottery was recovered from bulk soil sample 22, collected from deposit 10205. This sample also contained a small amount of charcoal, but no charred plant remains.
- 4.19.8 **Trench 103** was located east of Trench 102. Two possible ditches (10305 and 10307) were recorded in this trench, but they may have been remnant subsoil deposits that survived in a depression caused by a change in the underlying geology. Similarly, pit 10302 was in fact a naturally silted manganese-rich deposit and not an archaeological feature.
- 4.19.9 **Trench 104** was situated in the south-east corner of the site, east of Trench 103. It revealed large shallow pit 10404 (Plate 13). Approximately 1.89m wide and 0.22m deep, it was filled a deposit of brownish grey clay sand (10405). Several sherds of medieval pottery dating to c 1270–1350 were also recovered, clustered together on the base of the pit (Plate 14), as well as more than 50 small fragments of very eroded animal bone.
- 4.19.10 To the north-west of the pit was NW–SE aligned ditch 10406. It had a shallow concave profile, 0.24m and a fill of greyish brown sandy clay (10407). A small sherd of Roman pottery was recovered from this ditch.
- 4.19.11 Further to the north-west was a natural feature (10403) from which small quantities of Roman pottery and eroded animal bone were retrieved.
- 4.19.12 **Trench 111** was positioned to the south-west of Trench 104, adjacent to Stanford Road. It revealed shallow undated ditch 11106, truncated by a parallel adjacent ditch 11104 (Plate 15). The later ditch was filled with a naturally silted sequence of fills, with a final upper fill (11105). Small posthole 11102 was recorded cutting through deposit 11105, but due to the mottled nature of the deposits, this could be a misinterpretation of the sediments.
- 4.19.13 Ditch 11110 was a small feature just 0.36m wide and 0.04m deep. It contained an undated fill of brown silty clay.

## 4.20 Trenches 1, 5-7, 14, 15 and 17 (Figs 36 and 37)

- 4.20.1 This group of trenches were located in the western part of Land Parcel 35, east of Rectory Road and north of the A13. They were predominantly positioned to target a number of rectilinear cropmark features.
- 4.20.2 **Trench 1** was located in the north-west corner of the site in one of the areas devoid of cropmarks. At the south-west end of the trench was a narrow ditch

- (109). It measured 0.41m wide and 0.09m deep and was filled with a deposit of reddish-brown sandy silt. No finds were recovered from this feature.
- 4.20.3 Ditch 111 was situated a few metres to the east of ditch 109, on a parallel NNW–SSE orientation. It had a broad flat base and was 1.28m wide and 0.25m deep. It contained a primary fill of stony sand (113) overlain by a slowly accumulated sandy silt (112). Fill 112 produced two joining fragments of Roman tile.
- 4.20.4 Ditch 114 was only visible in section, adjacent to ditch 111. It had a shallow flat profile and a single undated fill (115).
- 4.20.5 Towards the north-east end of the trench was a row of three postholes (107, 105 and 103), aligned NE–SW (Plate 16). Each measured approximately 0.3m in diameter. They survived to between 0.09 and 0.22m deep. Deposit 104 from posthole 103 contained a small amount of post-medieval pottery and was the only one to yield any finds.
- 4.20.6 **Trench 5** was situated just over 70m to the south-east of Trench 1. It revealed E–W aligned ditch 503 near the centre of the trench. The shallow concave feature contained a deposit of greyish brown silty sand (504) from which animal bone fragments and post-medieval CBM were recovered. This ditch was closely aligned with a linear cropmark feature mapped close to this location.
- 4.20.7 Ditch 505 was recorded in plan at the northern end of the trench. Unexcavated at this location, its alignment suggested it was the same feature as ditch 604 in Trench 6.
- 4.20.8 **Trench 6** was located to the north-east of Trench 5 and contained ditch 604. It measured 1.64m wide and 0.48m deep with a fill of grey-brown silty clay and stones (605). No finds were recovered from the fill.
- 4.20.9 Near the centre of the trench and extending beyond the western baulk was sub-circular pit or tree-throw hole 607. It was filled with naturally accumulated sediments 608 and 609. The upper fill (608) contained several pieces of worked flint which had clearly been dumped in this feature.
- 4.20.10 **Trench 7** targeted a NNW–SSE aligned linear cropmark to the east of Trench 6. Two ditches (709 and 711) were revealed at the eastern end of the trench on this alignment. Based on its position, ditch 709 is mostly likely to have created the cropmark targeted. It measured 0.66m wide and 0.16m deep. It contained a primary fill (714) overlain by reddish grey sand silt deposit (710). Several fragments of post-medieval CBM were recovered from deposit 710.
- 4.20.11 Ditch 711 had steep sides and was 0.81m wide and 0.32m deep. It was filled with a greyish brown silty sand (713), overlain by a deposit of reddish grey sandy silty (712). Both deposits contained fragments of post-medieval CBM, whilst two sherds of early post-medieval pottery were also recovered from deposit 712.
- 4.20.12 In the south-west end of the trench were two undated pits or possible postholes (703 and 707), both measuring approximately 0.4m in diameter and 0.1m deep (Plate 17). In between these two was a third discrete feature

(705). It measured 0.51m wide and just 0.06m deep. It is unclear if this was also originally a posthole or a pit. A single sherd of Roman pottery was recovered from deposit 706, the fill of feature 705.

- 4.20.13 **Trench 14** was located to the south of Trench 7. It revealed NNW–SSE aligned ditch 1403. It measured 0.85m wide and 0.3m deep with steep sides and a flattish base. Filled with a single deposit silty sand (1404), no finds were recovered from this ditch. Ditch 1403 corresponds with a rectilinear cropmark feature which indicates that it was the same ditch at 803 to the north-east and 1507 to the south. Although not connected by the cropmarks, the orientation and profile of the ditch may also indicate that was a continuation of ditch 709 to the north.
- 4.20.14 **Trench 15** revealed three parallel ditches (1503, 1505 and 1507). Ditch 1507, at the western end of the trench, had a concave profile and was 0.98m wide and 0.24m deep. It was filled with a single sterile deposit (1508).
- 4.20.15 Ditch 1505 was located approximately 9m to the north-east. It had a shallow concave profile and was 0.54m wide and 0.17m deep with a naturally silted dark grey-brown silty sand fill (1506). Less than 0.2m to the north-east was ditch 1503, which measured 0.8m wide and 0.18m with a similar fill to 1506.
- 4.20.16 No dating evidence was recovered from any of these ditches, but their correlation to the cropmark evidence does indicate that they were part of the rectilinear enclosure system present here.
- 4.20.17 **Trench 17** was located to the south-east of Trench 5. It revealed a large ditch aligned ENE–WSW (1704). Ditch 1704 was only visible in the section of the trench, an appeared to be cut through the subsoil (1701) and had not been clearly identified during stripping. It measured 1.38m wide and 0.48m deep, with a concave base. It was filled with a single orange-brown silty sand (1705) and produced a small amount of presumably residual late Bronze Age pottery.
- 4.20.18 Also recorded in section and apparently cutting the subsoil was a pit or posthole (1706). It had a width of 0.41m and near-vertical sides, 0.5m deep. Its fill of dark grey-brown silty sand (1707) included both middle Bronze Age to Iron Age pottery and CBM fragments.
- 4.20.19 Although layer 1701 appeared to be a subsoil deposit, subsoil was absent from many of the trenches and the features recorded were usually sealed by this layer. Unless the features in Trench 17 were post-medieval in origin, it is more likely that layer 1701 is a change in the natural geology.

## 4.21 Trenches 8-11, 13 and 22 (Figs 38 and 39)

- 4.21.1 This group of trenches were located near the centre of the parcel, targeting the densest area of rectilinear cropmark features.
- 4.21.2 **Trench 8** revealed a single ditch (803), which the cropmarks indicated was probably linked to ditch 1403 to the south-west. Ditch 803 had steep sides and a wide concave base and was 1.28m wide and 0.38m deep. Its single fill consisted of sterile, greyish brown silty sand (804).
- 4.21.3 **Trench 9** was located to the north-east of Trench 8. It revealed a pair of parallel ditches aligned NNW–SSE at opposing ends of the trench (903 and

905). The ditches both had shallow concave profiles and sterile naturally silted fills. Both ditches also appeared to be related to similarly aligned cropmarks.

- 4.21.4 **Trench 10** was positioned to the south of Trench 9 targeting adjacent cropmark features. Ditch 1003 was recorded near the south-west end of the trench, corresponding to a NNW–SSE aligned cropmark. The ditch measured 0.72m wide and 0.16m deep. It was filled by sterile sandy silt deposit 1004.
- 4.21.5 At the north-east end of the trench, pit or ditch 1005 was recorded in plan extending beyond the limits of the excavated area. Broadly E–W aligned, it is likely that this was part of a corresponding linear cropmark. It may have been parallel to and contemporary with feature 1007, a small ditch recorded in section to the west of ditch 1005. No finds were recovered from either of these features.
- 4.21.6 **Trench 11** was located to the east of Trench 10 and revealed two features. Ditch terminus/pit 1105 was recorded at the northern end of the trench. It had a shallow, wide concave profile and was 0.58m wide and 0.1m deep and contained a naturally accumulated deposit (1106). Based on its position and nearby cropmarks, it is possible that this was the continuation of ditch 1005 in Trench 10.
- 4.21.7 Ditch 1103 was another undated feature with a shallow concave profile. Also corresponding with a cropmark feature, its NE–SW orientation is distinct from the majority of enclosure ditches recorded on this site and perhaps representative of a different phase of activity.
- 4.21.8 **Trench 13** targeted three linear cropmarks that were revealed as ditches 1303, 1305 and 1307. Each had a shallow concave profile and they were filled with slowly accumulated sterile deposits. Extrapolating the alignments, it is likely that 1303 formed part of the same boundary as ditch 1003 to the north. With ditches 1303 and 1305 on a perpendicular alignment to 1307, they appear to have been part of the same enclosure system.
- 4.21.9 **Trench 22** was located to the south of Trench 13 and recorded a ditch (2206) that was probably the continuation of ditch 1303 or 1305 from Trench 13. At this location it had steep sides and broad flattish base and was 1.18m wide and 0.24m deep but was also filled with a sterile undated deposit (2207). To the east of ditch 2206 was small possible posthole 2203. It measured 0.3m in diameter and contained brownish grey, silty sand deposit. Alternatively, it could have been part of adjacent animal burrow 2205.

## 4.22 Trenches 24, 25, and 27 (Figs 40 and 41)

- 4.22.1 This group of trenches were located in the south-east corner of Land Parcel 35. They were targeted on a penannular cropmark and other rectilinear cropmarks north of the A13.
- 4.22.2 **Trench 24** revealed single ditch 2403. It had a shallow concave profile and was 0.94m wide and 0.14m deep with a fill of grey-brown silty sand (2404). Aligned NE–SW, it matches one of the linear cropmarks targeted by the

trench. The second targeted cropmark may have passed to the south of the trench.

- 4.22.3 **Trench 25** was an L-shaped trench targeting perpendicular linear cropmarks. At the west end of the trench, ditch 2507 was revealed. The full depth of the ditch was not exposed, but it was 1.22m wide and at least 0.44m deep. The upper fill (2508) comprised grey-brown silty sand and included fragments of 18th/19th-century CBM and wood fragments. The finds recovered suggest a recent date, and although it matches a cropmark feature. There was no ditch mapped at this location on the 1st edition OS map.
- 4.22.4 Ditch 2503 had a steep side and a flat base, filled with greyish brown silty sand (2504). It was recut to the east by ditch 2505 which also had steep sides and a flattish base. It was filled by a similar, but darker deposit (2506). Neither ditch produced any finds.
- 4.22.5 **Trench 27** was located to the north of Trench 26, which had failed to identify anything that related to a penannular cropmark.
- 4.22.6 Ditch 2703 was recorded near the centre of the trench and corresponded with a cropmark feature with an ENE–WSW alignment. It had a concave profile and contained sterile naturally accumulate fill 2704.

## 4.23 Trenches 31-5 (Figs 42 and 43)

- 4.23.1 The group of trenches was situated in the north-east corner of the site. They were principally focused on the southern edge of a rectilinear enclosure cropmark.
- 4.23.2 **Trench 31** revealed several features relating to cropmarks. Ditch 3105 at the south-west end of the trench was a NNW–SSE aligned ditch, 1.3m wide and 0.34m deep, with steep sides and a narrow concave base (Plate 18). It contained two fills of naturally silted material, 3106 and 3107, neither of which produced any finds.
- 4.23.3 Ditch 3103 was located near the centre of the trench. The extent of this feature was difficult to define, but it appeared to be a gently sloped, rounded ditch terminus extending beyond the south-east baulk of the trench. Less than 0.2m deep, it contained a single fill of sterile light brown silty sand (3104).
- 4.23.4 At the north-east end of the trench was ditch 3109. It had steep sides and a rounded base and was 1.3m wide and 0.36m deep. Primary fill 3110 contained a sherd of 13th- to 15th-century pottery. The overlying deposit of reddish-brown silty sand (3111) was devoid of finds.
- 4.23.5 **Trench 32** revealed the very shallow remnants of NE–SW aligned ditch 3203. Just 0.07m deep and cut into sandy gravel geology, it was difficult to determine the relationship with perpendicular ditch 3205, but it appeared that 3205 was possibly the later feature. Based on the associated cropmarks, it would seem that ditch 3205 was part of a subdivision within a larger enclosure defined to the south by ditch 3203. No finds were recovered from either feature.
- 4.23.6 **Trench 33** revealed ditch 3303, which potentially forms a continuation of ditch 3203 from ditch 32. Ditch 3303 measured 0.86m wide with moderately

sloped sides and a concave base 0.18m deep. It contained a primary fill (3306) overlain by a deposit of dark grey silty sand (3305) and a final upper fill of brown-grey silty sand (3304). Deposit 3304 contained several sherds of Roman pottery. Soil sample 1, collected from fill 3304, produced charcoal and charred cereal grains of wheat and oat, chaff and weed seeds.

- 4.23.7 **Trench 34** was located to the east of Trench 33. At the east end of the trench small pit or posthole 3403 was recorded. It contained a moderate amount of charcoal suggesting the fill (3404) had been dumped into the feature, but no finds were recovered.
- 4.23.8 Adjacent to feature 3403 was NNW–SSE aligned ditch 3405. The shallow concave profile was filled with a sterile deposit of reddish-brown sandy silt (3406).
- 4.23.9 **Trench 35** was located to the south of Trench 34 and exposed narrow NE–SW aligned ditch 3503. It measured 0.5m wide and 0.14m deep and was filled with reddish brown silty sand devoid of artefacts.

## 4.24 Finds summary

- 4.24.1 **Prehistoric pottery.** A total of 59 sherds of prehistoric pottery (158g) was recovered. Much of the pottery is broadly dated to the middle Bronze Age to Iron Age period and comprises small and abraded sherds, though the early Neolithic and late Bronze Age are also represented within the small assemblage.
- 4.24.2 **Late Iron Age and Roman pottery.** An assemblage of Roman pottery comprising 216 sherds (3107g) was collected. Whilst a large proportion of the pottery could not be more closely dated within the Roman period, there is an emphasis on the middle Roman period and to a lesser extent the late Iron Age/early Roman period. It is possible that much of the material was manufactured locally.
- 4.24.3 **Medieval and post-medieval pottery.** Post-Roman pottery consisting of 128 sherds (1454g) largely dates to the late medieval period, though a few sherds of Anglo-Saxon, early post-medieval and 19th-century pottery have also been identified.
- 4.24.4 **Fired clay.** A single piece of fired clay was recovered, comprising a late Bronze Age perforated slab/plate.
- 4.24.5 **Ceramic building materials.** A total of 63 fragments of CBM (4.7kg) were retrieved, the majority consisting of post-medieval brick, floor tile and roof tile, though fragments of Roman and medieval/post-medieval tile were also identified.
- 4.24.6 **Metals.** Sixty-four iron objects (570.5g), including nails, rods and chain links, were collected, most of which are of late post-medieval or modern date. A worn and corroded copper alloy coin was also recovered and has been interpreted as a possible late 3rd-century AD radiate.
- 4.24.7 **Glass.** Seventeen shards of generally 19th- or early 20th-century glass were retrieved. Most comprise wine bottle fragments.
- 4.24.8 **Worked Stone.** Eight pieces of stone were recovered and retained for analysis. Two pieces (53g) comprise fragments of Mayen lava that may

have formed parts of rotary querns. They may be of Roman or medieval date. The remaining stone is unworked and unused.

- 4.24.9 **Flint.** An assemblage of 39 pieces of worked flint and over 1000 fragments of unworked burnt flint (3798g) was retrieved from the site. Much of the worked flint, which includes flakes, blades and a scraper, was residual in later features, though some pieces are of notable early Neolithic date. Although the large quantity of burnt material is largely undiagnostic, it is notable for having largely been recovered from three cremation burials.

## 4.25 Environmental summary

- 4.25.1 **Charred plant remains and charcoal.** Twenty-six bulk samples were collected. Material from ditches 3303, 4605 and pit 14205 are all good candidates for further analysis and will contribute to the final narrative for the site. There are also viable samples from each of the cremation cuts that can undergo further analysis for species identification. Twig roundwood in several samples offer opportunities for 14C dating, should it be required.
- 4.25.2 **Animal bone.** Approximately 139 pieces of animal bone (603g), which includes refitting fragments, were recovered from the site. The majority of the fragments are of unidentified mammal bones, though some taxa were identified, comprising cattle, horse, sheep/goat and mole. No evidence of articulation, burning, gnawing or butchery was observed.
- 4.25.3 **Human remains.** The human bone comprised three undated unurned deposits of cremated bone (13611 from pit 13610, 13612 from pit 13609 and 13614 from pit 13613). The remains were in keeping with adult, or possibly adolescent, remains, although no precise age or sex estimations could be made.



## 5 Discussion

---

### 5.1 Reliability of field investigation

- 5.1.1 The layout of trenches provided good overall coverage of the site. However, the need to omit several trenches due to uncharted services and limitations on access mean that small areas in each of the three land parcels could not be evaluated.
- 5.1.2 The conditions varied throughout the fieldwork, with periods of dry weather accompanied by frequent rainfall. Fortunately, the conditions did not hamper the investigations and provided a good opportunity for features to weather out. Across Land Parcel 35 and the eastern part of Land Parcel 3 this meant that the features were easily identified against the underlying sand, silts and clay of the Lambeth Group. The Boyn Hill Gravels revealed across much of Land Parcel 30, on the other hand, were dominated by naturally silted depressions which bore a close resemblance to archaeological features and are likely to have been the cause of the many discrete cropmarks. However, a large number of putative archaeological features were excavated across the site to ensure that archaeological remains did not go unrecognised.
- 5.1.3 The correlation between the cropmarks and the archaeological features was varied across the three land parcels, but generally favoured the ditched enclosure systems recorded in Land Parcels 3 and 35. In particular, there was a very good correlation between the cropmark features targeted by Trenches 135 to 150 and the archaeological remains they revealed. Inevitably, discrete features were underrepresented but the concentration of activity was particularly well indicated by the cropmarks in this area of the site. This is also the case for the north-east corner of Land Parcel 3 and Land Parcel 35, where most linear cropmarks were matched with underlying ditches.
- 5.1.4 The efficacy of the evaluation in identifying the features that generated the cropmarks is a good indicator for the reliability of this investigation. The only notable exception was the ring ditch targeted by Trench 26, where no corresponding archaeological feature was identified despite meticulous hand cleaning. Presumably the feature had been truncated by ploughing since it was first recorded. Overall, the identification of multiple features not previously recognised as cropmarks again demonstrates that the evaluation is a reliable indicator for the determining the archaeological potential of this site.

### 5.2 Interpretation

- 5.2.1 **Mesolithic/Neolithic.** The earliest feature recorded on the site was pit 8802, which produced several sherds of early Neolithic pottery. A serrated flint blade of the same date was recovered from the ploughsoil of the same trench. Other finds of pottery and flint have been tentatively dated to the same period from the adjacent Trench 96 and suggest there may have been a focus of activity in this corner of the site. However, there were many undated shallow pits and hollows from across the site that could easily have

been related to contemporary activity. Whether these remains represent settlement evidence or more transitory activity cannot be established on the basis of the limited remains from the evaluation. The proximity of the Orsett causewayed enclosure c 0.5km east of the site demonstrates that people would have been drawn to the area throughout this period and more remains of this date are likely given the limitations of trial trenching in identifying remains of this period.

- 5.2.2 **Late Bronze Age to Iron Age.** Evidence for late Neolithic and early Bronze Age activity is absent from the finds assemblage and late Bronze Age evidence is limited to a small quantity of pottery from ditch 1704 and a perforated clay slab from ditch 18402. Overall, the late Bronze Age and early Iron Age pottery recovered from the site comprised small abraded sherds from all three Land Parcels, although the majority was recovered from Land Parcel 30 and the higher ground at the east of Land Parcel 3.
- 5.2.3 The most notable assemblages from this period were those recovered from pit 9302 and ditches 10003 and 17603. The pottery from these features comprised several sherds and were less abraded than those recovered from the rest of the site. Similar features were found adjacent to these and were either undated or contained just small abraded sherds of middle Bronze Age or Iron Age pottery. At the very least these indicate the presence of a late prehistoric field system, but with the presence of postholes and pits, many of which are undated, it is possible that there are remnants of domestic occupation as well, although these features appeared to have been significantly truncated by subsequent agricultural activity.
- 5.2.4 A particularly good demonstration of the truncation that has taken place is provided by the annular cropmark targeted by Trenches 61 and 62. Due to the size and form of the cropmark, it is likely that this was generated by the remains of a Bronze Age barrow, but only a shallow ditch 0.12m survived, which was only recorded in the trench section.
- 5.2.5 **Late Iron Age and Early Roman.** The main phase of activity on the site appears to develop at the very beginning of the Roman period with a distinct focus in the southern part of Land Parcel 3. Trenches 135 to 150 were all targeted on a series of rectilinear cropmarks which previous phases of investigation (OA 2020b) have proven to be predominantly Roman in date.
- 5.2.6 During this phase of fieldwork, the principal enclosure targeted by Trenches 139, 140 and 141 appears to define and enclose the main focus of Roman settlement until the end of the 3rd century. Within the enclosure there is a dense concentration of features that comprise a series of ditched subdivisions as indicated by the cropmarks, alongside distinct settlement evidence indicated by clusters of shallow pits and postholes, particularly in Trenches 143, 145 and 148. The suggestion that this forms the focus of the settlement is further attested by the pottery assemblage, the preservation of which was best in Trenches 139, 140, 142, 143 and 150.
- 5.2.7 Beginning in the early Roman period, the peak of activity takes place in the late 2nd to mid-3rd century, with no evidence for continued occupation into 4th century. As expected, this demonstrates that the focus of activity was contemporary with and therefore a continuation of the occupation previously

identified at the Hornsby Lane site (OA 2020b). Although no further evidence for pottery production was identified, some of the material produced locally appears to have been used on site.

- 5.2.8 Whilst the first phase of evaluation revealed the remains of a Roman cremation burial in the enclosure to the east of Trench 149, no further burials were found in the vicinity during this investigation. However, the presence of a cemetery within the rectangular area defined by the cropmarks to the east of Trench 149 cannot be ruled out due to the potential for a scattered distribution of such features.
- 5.2.9 The three unurned cremation burials that were recorded in Trench 136, to the north of the enclosure, were undated. Given their proximity to the Roman settlement it is possible that they were contemporary, but equally the dispersed late prehistoric activity in the area may mean that they predate the Roman activity.
- 5.2.10 The ditched enclosures at the southern end of Land Parcel 3 provide a clear focus of activity during this period, but evidence from across the rest of the site indicates a more widespread impact on the landscape. These included ditches in Trenches 186 and 172 on the higher ground at the east of Land Parcel 3, which both contained Roman pottery. The pair of parallel ditches in Trench 172 were both aligned with a pair of linear cropmarks and suggest the presence of a driveway or track, perhaps connecting the settlement at Heath Place to the area around Orsett Cock.
- 5.2.11 A small apparently isolated assemblage of Roman pottery from ditch 3303 accompanied by charred remains of wheat and barley is likely to be the at the periphery of a separate Roman focus, extending to the north and defined by the cropmark complex recorded in this area.
- 5.2.12 Further scattered remains of Roman material recovered from across Land Parcels 30 and 35 were generally abraded, showed signs of reuse or were residual in later contexts. This indicates a broader spread of Roman activity, but this was clearly distanced from the main settlement foci. The large network of NNW–SSE aligned enclosures that spread along and to the north of the A13 at this location probably has its origins in the Roman period.
- 5.2.13 **Medieval.** A single Anglo-Saxon pit was recorded near the centre of Land Parcel 30 in Trench 76 and is the only feature encountered of this date. The absence of any contemporary activity is perhaps surprising given the evidence for contemporary settlement at Orsett Cock and the Anglo-Saxon cemetery at the Heath Place causewayed enclosure.
- 5.2.14 Further medieval evidence was equally sporadic and only occurred in isolated, scattered contexts. Nearly 1kg of 13th/14th century pottery was recovered from a single pit, 10404. The feature itself was almost completely truncated by ploughing and without any obviously contemporary features it is unclear how this material came to be deposited here.
- 5.2.15 A small quantity of late medieval pottery was also recovered from ditch 14115 in the south of Land Parcel 3. However, this feature appears to be part of the Roman settlement enclosure so it is possible that the pottery was intrusive, introduced from one of several later features that intersect the ditch at this location.

- 5.2.16 **Post-medieval.** Activity during this period was limited and mostly represented by a scatter of small sherds of redware across the site. In the absence of any specific features or foci it would appear that activity during this post-medieval period was mostly agricultural in nature.
- 5.2.17 **Undated.** Many of the features across the three land parcels were undated. Given the nature of the geology, it is possible that some of these were simply of natural or geological origin. Others may have been so substantially truncated by ploughing that they left only shallow remnants without finds, or they may have lacked artefactual inclusions because they were peripheral to any areas of contemporary activity. It has been suggested already that many of these features may be the remains of scattered late prehistoric settlement and field systems, or in the case of the NNW–SSE aligned field systems they were established during the Roman period, matching the alignment of the enclosures at Hornsby Lane and Heath Place. However, the evidence for scattered activity from the early Neolithic through to the late medieval period prevents a firm conclusion from being drawn.

## 5.3 Evaluation objectives and results

### General Aims

- 5.3.1 **Aims i-iii.** The evaluation established the presence of archaeological remains from the early Neolithic through to the late medieval period and also identified several areas that were devoid of archaeological features. Overall, the cropmark data has been proven to be reasonably reliable for identifying the areas of archaeological activity, but as is often the case it was not a good indicator for the density of activity or for locating discrete features. In Land Parcel 30 in particular, numerous linear and discrete features were revealed that had not been indicated as cropmark features.
- 5.3.2 **Aim iv.** The evaluation demonstrated that the greatest complexity of archaeology was located in the southern part of Land Parcel 3, where the Roman settlement was focused. However, even in the densest areas of activity, the remains appeared to have been truncated by ploughing, leaving mostly shallow features and simple stratigraphy. As indicated by the largely flat topography, no deep sediment sequences or buried archaeological horizons were encountered with the exception of Trench 171, which revealed the beginning of a dry valley, although this was almost entirely beyond the site boundary.
- 5.3.3 **Aims v-vi.** The evaluation has established the date of the remains present, the state and preservation of the archaeological artefacts and has provided a good indication about the potential for information about the economy, status and past inhabitants of the site.
- 5.3.4 **Aim vii.** Paleoenvironmental samples were recovered and have demonstrated the state of preservation and level of potential for environmental information.

### Specific Objectives

- 5.3.5 **Aim xiii.** The evaluation was conducted within the parameters and objectives of the revised East of England Research Framework (Medlycott

2011) and takes account of the aims and objectives of the Greater Thames Estuary Historic Environment Research Framework.

- 5.3.6 **Aim xiv.** The evaluation has demonstrated that, where present, the cropmark data is an accurate indicator for the presence of underlying remains, with the exception of the penannular feature in Land Parcel 35, which could not be related to any underlying feature, suggesting that significant truncation has taken place since the cropmark was recorded.
- 5.3.7 Targeting of the apparently blank areas has shown that not all archaeological features have led to the development of cropmarks in these fields. Particularly across Land Parcel 30, there were a number of linear features that did not correspond with mapped cropmarks. It has also shown that whilst the cropmarks can provide an indication for an area of activity, in this case it is not a reliable indicator for the density of remains that were present.
- 5.3.8 **Aim xv.** No finds of Mesolithic date were recovered during the fieldwork, but a single pit dating to the early Neolithic period was located. This along with other findspots of flint and possible early Neolithic pottery demonstrate that remains of this date are present. However, their limited number prevents any meaningful conclusions to be drawn about their relationship with the causewayed enclosure and the wider landscape.
- 5.3.9 **Aim xvi.** No remains were encountered that could be attributed to the later Neolithic or early Bronze Age.
- 5.3.10 **Aim xvii.** The circular ring ditch indicated by a cropmark within Land Parcel 30 could not be located during the excavations and is likely to have been truncated away by ploughing. The annular cropmark investigated by Trenches 61 and 62 had similarly been significantly truncated by ploughing and survived to a depth of only 0.12m. Its date may be indicated by the recovery of several small sherds of possible early Neolithic pottery.
- 5.3.11 **Aim xviii.** Features dating to the late Bronze Age and Iron Age were recorded from all areas of the three Land Parcels investigated. However, these were sparsely distributed with no discernible focus of activity. This is perhaps an indication that the sites were short-lived and shifting, but given the likelihood that these sites are also somewhat truncated, the picture remains unclear at this stage.
- 5.3.12 **Aim xix.** Whilst later prehistoric features were encountered across each of the areas investigated, the inability to recognise any distinct later prehistoric focus means that it is not possible to determine whether there was a topographic preference. Furthermore, the sites investigated during this stage of fieldwork were predominantly located on relatively flat ground and do not provide enough coverage of low-lying or higher ground to reach an informed conclusion about preferences for one or the other.
- 5.3.13 **Aim xx.** The extent, character and density of the Roman activity has been established, especially when considered in conjunction with the results of the Hornsby Lane evaluation in the adjacent fields (OA 2020b). The undated cropmark enclosures north of the A13 produced very little dating evidence during the evaluation. However, the larger rectangular enclosure to the east, targeted by Trenches 31, 32, 33 and 34 did produce Roman

material in Trench 33 and is likely to be of this date. The parallel ditches in Trench 7 contained post-medieval finds and clearly indicate a different phase of field systems.

- 5.3.14 Overall, it would appear that a pattern of NNW–SSE aligned field systems was established by the Roman period and became fossilised in the landscape, with subsequent additions following the same broad alignments.
- 5.3.15 **Aim xxi.** Although Roman pottery was recovered that had been locally produced at either Orsett Cock or Hornsby Lane, no pottery kilns were revealed during this phase of investigations. No evidence for Roman roads was discovered.
- 5.3.16 **Aim xxii.** As has been established elsewhere on the LTC scheme in Essex, many of the pit-like cropmarks revealed on the gravel geology are caused by shallow silt pockets in the surface of the gravels. However, they can also provide accurate evidence for features, and the pit-like cropmarks targeted with the open area Trench 148 did correlate with small pits of Roman date. The cropmarks across Land Parcel 30, on the other hand, appeared to have been caused by a combination of undated pits and geological features.
- 5.3.17 **Aim xxiii.** The discovery of a single Anglo-Saxon feature, more than 1km from contemporary evidence at the causewayed enclosure and Orsett Cock, provides little additional information, although it does confirm that this activity did not extend in any significant concentration to the west of these known sites.
- 5.3.18 **Aim xxiv.** Although there is some evidence that the enclosure systems begun in the Roman period and continued to develop through the medieval and post-medieval periods, there is limited evidence to date the associated roads and driveways, except to note that these tend to follow the same alignments of the field systems and are likely to be broadly contemporary.
- 5.3.19 **Aim xxv.** Despite the evidence for medieval activity on the site, no remains of any medieval or post-medieval farmsteads were encountered.

## Appendix A Trench Tables

Trench 1							
General description					Orientation		E-W
Trench revealed two ditches and three postholes. Trench consists of ploughsoil and subsoil overlying a sandy gravel natural.					Length (m)		30
					Width (m)		2
					Avg. depth (m)		0.35
Context No.	Type	Fill Of	Width (m)	Depth (m)	Description	Findings	Date
100	Layer			0.24	Ploughsoil. Loose mid brownish grey, sandy silt.		
101	Layer			0.03	Subsoil. Loose light yellowish brown, sandy silt.		
102	Layer				Natural. Soft light orangish and yellowish brown, silty sand and gravel.		
103	Cut		0.32	0.23	Posthole		
104	Fill	103	0.32	0.23	Primary Fill. Loose mid reddish brown silt sand	Pot	PMed
105	Cut		0.32	0.09	Posthole		
106	Fill	105	0.32	0.09	Primary Fill. Loose mid reddish brown silt sand		
107	Cut		0.3	0.1	Posthole		
108	Fill	107	0.3	0.1	Primary Fill. Loose mid reddish brown silt sand		
109	Cut		0.41	0.09	Ditch		
110	Fill	109	0.41	0.09	Primary Fill. Loose mid reddish brown sandy silt.		
111	Cut		1.28	0.25	Ditch		
112	Fill	111	1.28	0.36	Secondary Fill. Loose mid reddish brown sandy silt.	CBM	Roman
113	Fill	111	0.92	0.1	Primary Fill. Friable mid greyish brown gravelly sand.		
114	Cut		0.93	0.15	Ditch		
115	Fill	114	0.93	0.15	Primary Fill. Loose, mid reddish brown, sandy silt.		
Trench 2							
General description					Orientation		
					Length (m)		
					Width (m)		
					Avg. depth (m)		

Context No.	Type	Fill Of	Width (m)	Depth (m)	Description	Finds	Date
<b>Trench 3</b>							
General description					Orientation		
					Length (m)		
					Width (m)		
					Avg. depth (m)		
Context No.	Type	Fill Of	Width (m)	Depth (m)	Description	Finds	Date
<b>Trench 4</b>							
General description					Orientation		
					Length (m)		
					Width (m)		
					Avg. depth (m)		
Context No.	Type	Fill Of	Width (m)	Depth (m)	Description	Finds	Date
<b>Trench 5</b>							
General description					Orientation		NW-SE
Trench revealed two ditches. Trench consists of ploughsoil and subsoil overlying a sandy gravel natural.					Length (m)		30
					Width (m)		2
					Avg. depth (m)		0.45
Context No.	Type	Fill Of	Width (m)	Depth (m)	Description	Finds	Date
500	Layer			0.3	Ploughsoil. Loose mid brownish grey, sandy silt.		
501	Layer			0.15	Subsoil. Loose light yellowish brown, sandy silt.		
502	Layer				Natural. Soft light orangish and yellowish brown, silty sand and gravel.		
503	Cut		1.1	0.16	Ditch		
504	Fill	503	1.1	0.16	Deliberate Backfill. Moderately friable mid greyish brown silty sand with occasional charcoal and CBM flecks. Contained CBM and bone.	CBM, animal bone	C17-18
505	Unexcavated feature				Ditch. mid brown sandy silt		
<b>Trench 6</b>							
General description					Orientation		NE-SW



Trench revealed one ditch and a possible pit. Trench consists of ploughsoil and subsoil overlying a sandy gravel natural.						Length (m)	30
						Width (m)	2
						Avg. depth (m)	0.55
Context No.	Type	Fill Of	Width (m)	Depth (m)	Description	Finds	Date
600	Layer			0.25	Ploughsoil. Loose mid brownish grey, sandy silt.		
601	Layer			0.3	Subsoil. Loose light yellowish brown, sandy silt.		
602	Layer				Natural. Soft light reddish brown sandy gravels		
603	Void						
604	Cut		1.64	0.48	Ditch		
605	Fill	604	1.64	0.48	Deliberate Backfill. Compact mid greyish brown silty clay		
606	Void						
607	Cut		0.92	0.21	Pit		
608	Fill	607	0.92	0.21	Secondary Fill. Compact light brownish grey silty clay.		
609	Fill	607	0.6	0.1	Primary Fill. Compact mid brownish red silty clay		

### Trench 7

General description						Orientation	E-W
Trench revealed three postholes and two ditches. Trench consists of ploughsoil and subsoil overlying a sandy gravel natural.						Length (m)	30
						Width (m)	2
						Avg. depth (m)	0.45
Context No.	Type	Fill Of	Width (m)	Depth (m)	Description	Finds	Date
700	Layer			0.25	Ploughsoil. Mid brown-grey sandy silt		
701	Layer			0.18	Subsoil. Light yellowish brown gravelly sand		
702	Layer				Natural. Light reddish brown silt sand		
703	Cut		0.42	0.1	Posthole		
704	Fill	703	0.42	0.1	Primary Fill. Mid reddish grey sandy silt		
705	Cut		0.51	0.06	Posthole		
706	Fill	705	0.51	0.06	Primary Fill. Loose mid reddish grey sandy silt	Pot	Roman

707	Cut		0.31	0.1	Posthole		
708	Fill	707	0.31	0.1	Primary Fill. Loose mid reddish grey sandy silt		
709	Cut		0.66	0.16	Ditch		
710	Fill	709	0.66	0.08	Secondary Fill. Loose mid reddish grey sandy silt	CBM	PMed
711	Cut		0.81	0.32	Ditch		
712	Fill	711	0.81	0.07	Secondary Fill. Loose mid reddish grey sandy silt	Pot, CBM	EPMed
713	Fill	711	0.75	0.26	Primary Fill. Friable mid greyish brown silty sand.	CBM	C16-17
714	Fill	709	0.47	0.07	Primary Fill. Friable mid reddish brown silty sand		

### Trench 8

General description		Orientation	NE-SW
Trench revealed one ditch. Trench consists of ploughsoil and subsoil overlying a sandy gravel natural.		Length (m)	27
		Width (m)	2
		Avg. depth (m)	0.33

Context No.	Type	Fill Of	Width (m)	Depth (m)	Description	Finds	Date
800	Layer			0.33	Ploughsoil. Loose mid brownish grey sandy silt.		
801	Layer			0.14	Subsoil. Loose light yellowish brown, sandy silt.		
802	Layer				Natural. Soft light reddish brown sandy gravels.		
803	Cut		1.28	0.38	Ditch		
804	Fill	803	1.3	0.3	Primary Fill. Soft mid greyish brown silty sand.		

### Trench 9

General description		Orientation	E-W
Trench revealed 3 ditches. Trench consists of ploughsoil and subsoil overlying a sandy gravel natural.		Length (m)	30
		Width (m)	2
		Avg. depth (m)	0.4

Context No.	Type	Fill Of	Width (m)	Depth (m)	Description	Finds	Date
900	Layer			0.3	Ploughsoil. Loose mid brownish grey, sandy silt		
901	Layer			0.15	Subsoil. Loose light yellowish brown, sandy silt.		

902	Layer				Natural. Soft light reddish brown sandy gravels.		
903	Cut		1.28	0.44	Ditch		
904	Fill	903	1.28	0.44	Primary Fill. Loose mid brownish grey silty sand.		
905	Cut		1.34	0.3	Ditch		
906	Fill	905	1.34	0.3	Primary Fill. loose mid greyish brown sandy silt.		

### Trench 10

General description					Orientation	NE-SW
Trench revealed two ditches. Trench consists of ploughsoil and subsoil overlying a sandy gravel natural.					Length (m)	30
					Width (m)	2
					Avg. depth (m)	0.5

Context No.	Type	Fill Of	Width (m)	Depth (m)	Description	Finds	Date
1000	Layer		2	0.3	Ploughsoil. loose mid brownish grey sandy silt.		
1001	Layer		2	0.15	Subsoil. mid yellowish brown sandy silt.		
1002	Layer		2		Natural. light yellowish brown clayey sand.		
1003	Cut		0.74	0.14	Ditch		
1004	Fill		0.74	0.14	Primary Fill. Loose mid greyish brown silty sand.		
1005	Unexcavated feature		1.78		Ditch. Mid grey-brown sandy silt.		
1006	Fill	1003	1.78		Primary Fill. Unexcavated. Friable mid greyish brown, silty sand		
1007	Cut		0.7	0.32	Ditch. Section in bulk		
1008	Fill	1007	0.7	0.32	Primary Fill. Friable mid reddish grey silty sand		
1009	Void						

### Trench 11

General description					Orientation	N-S
Trench revealed one ditch and one possible pit. Trench consists of ploughsoil and subsoil overlying a sandy gravel natural.					Length (m)	30
					Width (m)	2
					Avg. depth (m)	0.55

Context No.	Type	Fill Of	Width (m)	Depth (m)	Description	Finds	Date
-------------	------	---------	-----------	-----------	-------------	-------	------

1100	Layer		2	0.28	Ploughsoil. loose mid greyish brown sandy silt.		
1101	Layer			0.27	Subsoil. light reddish grey sandy silt.		
1102	Layer				Natural. Light reddish brown sandy gravels.		
1103	Cut		0.78	0.22	Ditch		
1104	Fill	1103	0.78	0.22	Primary Fill. loose mid greyish brown, sandy silt.		
1105	Cut		0.58	0.1	Ditch. Possible ditch terminus or pit		
1106	Fill	1105	0.58	0.1	Primary Fill. Loose light greyish brown, sandy silt.		

### Trench 12

General description				Orientation		NW-SE	
Trench devoid of archaeology and consists of ploughsoil and subsoil overlying a sandy gravel natural.				Length (m)		30	
				Width (m)		2	
				Avg. depth (m)		0.65	

Context No.	Type	Fill Of	Width (m)	Depth (m)	Description	Finds	Date
1200	Layer			0.34	Ploughsoil. Loose mid brownish grey, sandy silt.		
1201	Layer			0.34	Subsoil. Loose yellowish and greyish brown sandy silt and gravel.		
1202	Layer				Natural. soft light reddish brown sandy gravels.		

### Trench 13

General description				Orientation		NE-SW	
Trench revealed three ditches. Trench consists of ploughsoil and subsoil overlying a sandy gravel natural.				Length (m)		30	
				Width (m)		2	
				Avg. depth (m)			

Context No.	Type	Fill Of	Width (m)	Depth (m)	Description	Finds	Date
1300	Layer			0.31	Ploughsoil. Loose mid brownish grey sandy silt.		
1301	Layer			0.14	Subsoil. Soft light yellowish brown sandy silt.		
1302	Layer				Natural. Loose light yellowish brown sandy gravel		

1303	Cut		0.88	0.22	Ditch		
1304	Fill	1303	0.88	0.22	Primary Fill. Loose Mid greyish brown gravelly sand		
1305	Cut		0.8	0.14	Ditch		
1306	Fill	1305	0.8	0.14	Primary Fill. Loose mid greyish brown silty sand		
1307	Cut		1	0.22	Ditch		
1308	Fill		1	0.08	Secondary Fill. Mid greyish brown gravelly sand.		
1309	Fill	1307	0.85	0.04	Primary Fill. Friable mottled mid reddish grey silty sand.		

#### Trench 14

General description					Orientation		E-W
Trench revealed one ditch. Trench consists of ploughsoil and subsoil overlying a sandy gravel natural.					Length (m)		30
					Width (m)		2
					Avg. depth (m)		0.5
Context No.	Type	Fill Of	Width (m)	Depth (m)	Description	Finds	Date
1400	Layer			0.29	Ploughsoil. Loose mid brownish grey sandy silt		
1401	Layer		2.1	0.28	Subsoil. Mid yellowish brown silty sand with occasional sub-angular stones.		
1402	Layer		2		Natural. Soft mid yellowish brown sandy gravels		
1403	Cut		0.85	0.3	Ditch		
1404	Fill	1403	0.85	0.3	Primary Fill. Soft mid greyish brown silty sand		

#### Trench 15

General description					Orientation		E-W
Trench revealed three ditches. Trench consists of ploughsoil and subsoil overlying a sandy gravel natural.					Length (m)		30
					Width (m)		2
					Avg. depth (m)		0.5
Context No.	Type	Fill Of	Width (m)	Depth (m)	Description	Finds	Date
1500	Layer		2	0.3	Ploughsoil. Loose mid brownish grey sandy silt.		
1501	Layer		2	0.2	Subsoil. Light yellowish brown sandy silt.		
1502	Layer		2		Natural. Light yellowish brown sandy gravel.		

1503	Cut		0.8	0.18	Ditch		
1504	Fill	1503	0.8	0.18	Primary Fill. dark grey-brown sandy silt		
1505	Cut		0.54	0.17	Ditch		
1506	Fill	1505	0.54	0.17	Primary Fill. dark grey-brown silty sand		
1507	Cut		0.98	0.24	Ditch		
1508	Fill	1507	0.98	0.24	Primary Fill. mid grey-brown silty sand		

### Trench 16

General description		Orientation	E-W
Trench devoid of archaeology. Trench consists of ploughsoil and subsoil overlying a sandy gravel natural.		Length (m)	30
		Width (m)	2
		Avg. depth (m)	0.4

Context No.	Type	Fill Of	Width (m)	Depth (m)	Description	Finds	Date
1600	Layer			0.2	Ploughsoil. Loose mid brownish grey, sandy silt.		
1601	Layer			0.2	Subsoil. Loose light yellowish brown, sandy silt.		
1602	Layer				Natural. Soft light reddish brown sandy gravels.		

### Trench 17

General description		Orientation	NW-SE
Trench revealed one ditch and one posthole. Trench consists of ploughsoil and subsoil overlying a sandy gravel natural. Contains one ditch and one porthole.		Length (m)	30
		Width (m)	2
		Avg. depth (m)	0.5

Context No.	Type	Fill Of	Width (m)	Depth (m)	Description	Finds	Date
1700	Layer			0.31	Ploughsoil. Loose mid brownish grey, sandy silt.		
1701	Layer			0.3	Subsoil. Loose light greyish brown, sandy silt.		
1702	Void						
1703	Layer				Natural. Soft light yellowish and orangish brown silty sand, with dense patches of gravel.		
1704	Cut		1.38	0.48	Ditch		
1705	Fill	1704	1.38	0.48	Primary Fill. Loose, mid orange-brown, sandy silt.	Pot	LBA (res?)

1706	Cut		0.42	0.5	Posthole		
1707	Fill	1706	0.42	0.5	Primary Fill. Loose dark greyish brown, sandy silt.	Pot	MBA-IA
<b>Trench 18</b>							
General description					Orientation		
					Length (m)		
					Width (m)		
					Avg. depth (m)		
Context No.	Type	Fill Of	Width (m)	Depth (m)	Description	Finds	Date
<b>Trench 19</b>							
General description					Orientation		
					Length (m)		
					Width (m)		
					Avg. depth (m)		
Context No.	Type	Fill Of	Width (m)	Depth (m)	Description	Finds	Date
<b>Trench 20</b>							
General description					Orientation		NW-SE
Trench devoid of archaeology. Trench consists of ploughsoil and subsoil overlying a sandy gravel natural.					Length (m)		30
					Width (m)		2
					Avg. depth (m)		0.5
Context No.	Type	Fill Of	Width (m)	Depth (m)	Description	Finds	Date
2000	Layer			0.25	Ploughsoil. Loose mid-brownish grey, sandy silt.		
2001	Layer			0.25	Subsoil. Loose light pale yellowish brown, sandy silt.		
2002	Layer				Natural. Loose light grey silty sand and gravel.		
<b>Trench 21</b>							
General description					Orientation		NE-SW
Trench devoid of archaeology. Trench consists of ploughsoil and subsoil overlying a sandy gravel natural.					Length (m)		30
					Width (m)		2
					Avg. depth (m)		0.4
Context No.	Type	Fill Of	Width (m)	Depth (m)	Description	Finds	Date
2100	Layer			0.2	Ploughsoil. Loose mid brownish grey sandy silt.		
2101	Layer			0.2	Subsoil. Loose light pale greyish brown, sandy silt.		

2102	Layer				Natural. Loose light pale grey silty sand and gravel.		
<b>Trench 22</b>							
General description					Orientation	E-W	
Trench revealed one ditch and one posthole. Trench consists of ploughsoil and subsoil overlying a sandy gravel natural.					Length (m)	30	
					Width (m)	2	
					Avg. depth (m)	0.45	
Context No.	Type	Fill Of	Width (m)	Depth (m)	Description	Finds	Date
2200	Layer			0.35	Ploughsoil. Loose mid brownish grey sandy silt		
2201	Layer			0.15	Subsoil. Mid yellowish grey silty sand with patches of gravel.		
2202	Layer				Natural. Mid yellowish brown sandy gravel		
2203	Cut		0.3	0.08	Posthole		
2204	Fill	2203	0.3	0.08	Primary Fill. Mid brownish grey silty sand		
2205	Cut	2205			Natural Feature. Rooting, animal burrow.		
2206	Cut		1.18	0.24	Ditch		
2207	Fill	2206	1.18	0.24	Primary Fill. Mid reddish brown silty sand		
<b>Trench 23</b>							
General description					Orientation	NE-SW	
Trench devoid of archaeology. Trench consists of ploughsoil and subsoil overlying a sandy gravel natural.					Length (m)	30	
					Width (m)	2	
					Avg. depth (m)	0.6	
Context No.	Type	Fill Of	Width (m)	Depth (m)	Description	Finds	Date
2300	Layer			0.4	Ploughsoil. Loose mid greyish brown sandy silt.		
2301	Layer			0.14	Subsoil. Mid greyish brown sandy silt		
2302	Layer		2		Natural. mid reddish grey sandy gravels.		
2303	Cut	2303			Natural Feature. Geological disturbance		
<b>Trench 24</b>							



General description					Orientation		NW-SE
Trench revealed one ditch. Trench consists of ploughsoil and subsoil overlying a sandy gravel natural.					Length (m)		30
					Width (m)		2
					Avg. depth (m)		0.45
Context No.	Type	Fill Of	Width (m)	Depth (m)	Description	Finds	Date
2400	Layer			0.25	Ploughsoil. Loose mid brownish grey, sandy silt.		
2401	Layer			0.2	Subsoil. Loose light orange-brown, sandy silt.		
2402	Layer				Natural. Loose light orange-brown and white sand and gravel.		
2403	Cut		0.94	0.14	Ditch		
2404	Fill	2403	0.94	0.14	Primary Fill. Friable mid greyish brown silty sand		

### Trench 25

General description					Orientation		NE-SW to NW-SE
Trench revealed two ditches. Trench consists of ploughsoil and subsoil overlying a sandy gravel natural.					Length (m)		40
					Width (m)		2.2
					Avg. depth (m)		0.55
Context No.	Type	Fill Of	Width (m)	Depth (m)	Description	Finds	Date
2500	Layer			0.3	Ploughsoil. Loose mid brownish grey sandy silt.		
2501	Layer			0.35	Subsoil. Loose light yellowish brown, sandy silt.		
2502	Layer				Natural. light grey-brown sandy gravels.		
2503	Cut		1	0.26	Ditch		
2504	Fill	2503	1	0.26	Primary Fill. Mid greyish brown silty sand		
2505	Cut		0.96	0.3	Ditch		
2506	Fill	2505	0.96	0.3	Primary Fill. Dark greyish brown silty sand		
2507	Cut		1.22	0.44	Ditch. Modern. Not fully excavated as went over 1m depth.		
2508	Fill	2507	1.22	0.44	Primary Fill. Mid greyish brown silty sand	CBM	C18-19

2509	Cut	2509			Natural Feature. Animal burrow		
<b>Trench 26</b>							
General description					Orientation		NE-SW
Trench devoid of archaeology. Trench consists of ploughsoil and subsoil overlying a sandy gravel natural.					Length (m)		30
					Width (m)		2.2
					Avg. depth (m)		0.45
Context No.	Type	Fill Of	Width (m)	Depth (m)	Description	Finds	Date
2600	Layer			0.3	Ploughsoil. Loose mid brownish grey, sandy silt.		
2601	Layer			0.13	Subsoil. Loose light yellowish brown, sandy silt.		
2602	Layer				Natural. Soft light reddish brown sandy gravels.		
2603	Cut				Natural Feature. Natural sand and rooting. Thought to be possible ring ditch however it was not.		
<b>Trench 27</b>							
General description					Orientation		NW-SE
Trench revealed one ditch. Trench consists of ploughsoil and subsoil overlying a sandy gravel natural.					Length (m)		30
					Width (m)		2.2
					Avg. depth (m)		0.55
Context No.	Type	Fill Of	Width (m)	Depth (m)	Description	Finds	Date
2700	Layer			0.25	Ploughsoil. Loose mid brownish grey sandy silt.		
2701	Layer			0.3	Subsoil. Loose light yellowish brown, sandy silt.		
2702	Layer				Natural. Loose light grey-brown sandy gravels.		
2703	Cut		1.24	0.28	Ditch		
2704	Fill	2703	1.24	0.28	Primary Fill. Mid greyish brown silty sand		
<b>Trench 28</b>							
General description					Orientation		NE-SW
Trench devoid of archaeology. Trench consists of ploughsoil and subsoil overlying a sandy gravel natural.					Length (m)		30
					Width (m)		2.2
					Avg. depth (m)		0.43

Context No.	Type	Fill Of	Width (m)	Depth (m)	Description	Finds	Date
2800	Layer		2	0.28	Ploughsoil. Loose mid greyish brown sandy silt		
2801	Layer		2	0.15	Subsoil. Firm mid yellowish brown with gravel inclusions, silty sand		
2802	Layer		2		Natural. Firm light yellowish brown with patches of white and gravel inclusions, silty sand		

### Trench 29

General description	Orientation	E-W
Trench devoid of archaeology. Trench consists of ploughsoil overlying a sandy gravel natural.	Length (m)	30
	Width (m)	2.2
	Avg. depth (m)	0.3

Context No.	Type	Fill Of	Width (m)	Depth (m)	Description	Finds	Date
2900	Layer			0.3	Ploughsoil. Loose mid brownish grey sandy silt.		
2901	Layer				Natural. Loose light orange-brown and white sand and gravel.		

### Trench 30

General description	Orientation	NW-SE
Trench devoid of archaeology. Trench consists of ploughsoil and subsoil overlying a sandy gravel natural.	Length (m)	30
	Width (m)	2
	Avg. depth (m)	0.45

Context No.	Type	Fill Of	Width (m)	Depth (m)	Description	Finds	Date
3000	Layer		2	0.25	Ploughsoil. Loose mid brownish grey sandy silt		
3001	Layer		2	0.2	Subsoil. Firm mid yellowish brown with gravel inclusions, silty sand		
3002	Layer		2		Natural. Firm light yellowish brown with white patches and gravel inclusions, silty sand		

### Trench 31

General description					Orientation		NE-SW
Trench revealed two ditches and one pit. Trench consists of ploughsoil and subsoil overlying a sandy gravel natural.					Length (m)		59.4
					Width (m)		2
					Avg. depth (m)		0.4
Context No.	Type	Fill Of	Width (m)	Depth (m)	Description	Finds	Date
3100	Layer		2	0.19	Ploughsoil. Loose mid brownish grey sandy silt		
3101	Layer		2	0.21	Subsoil. Firm mid yellowish brown sandy clay		
3102	Layer		2		Natural. Soft light yellowish brown sandy gravels.		
3103	Cut		9.96	0.17	Pit		
3104	Fill	3103	2.96	0.17	Primary Fill. Friable light yellowish brown silty sand.		
3105	Cut		1.3	0.34	Ditch		
3106	Fill	3105	1.3	0.16	Secondary Fill. Mid greyish brown gravelly sand, loose.		
3107	Fill		0.8	0.18	Primary Fill. Light greyish yellow sand, compact.		
3108	Cut				Natural Feature. Rooting. Mottled dark reddish grey gravelly sand		
3109	Cut		1.3	0.38	Ditch		
3110	Fill	3109	1.1	0.2	Primary Fill. Mixed compact brownish yellow clayey sand	Pot	C13-15
3111	Fill	3109	1.1	0.18	Secondary Fill. Soft mid reddish brown silty sand		
<b>Trench 32</b>							
General description					Orientation		NE-SW
Trench revealed two ditches. Trench consists of ploughsoil and subsoil overlying a sandy gravel natural.					Length (m)		37
					Width (m)		2
					Avg. depth (m)		0.45
Context No.	Type	Fill Of	Width (m)	Depth (m)	Description	Finds	Date
3200	Layer		2	0.25	Ploughsoil. Loose mid brownish grey sandy silt		
3201	Layer		2	0.2	Subsoil. mid yellowish brown sandy clay		

3202	Layer				Natural. light yellowish brown sandy gravels.		
3203	Cut		1	0.28	Ditch		
3204	Fill	3203	1	0.28	Primary Fill. soft light greyish yellow silty sand.		
3205	Cut		1	0.19	Ditch		
3206	Fill	3205	1	0.19	Primary Fill. Loose light yellowish brown sandy gravel.		

### Trench 33

General description					Orientation		NW-SE
Trench revealed one ditch. Trench consists of a ploughsoil, and subsoil overlying a sandy gravel natural.					Length (m)		45
					Width (m)		2
					Avg. depth (m)		0.55
Context No.	Type	Fill Of	Width (m)	Depth (m)	Description	Finds	Date
3300	Layer		2	0.3	Ploughsoil. Loose mid brownish grey sandy silt		
3301	Layer		2	0.25	Subsoil. mid yellowish brown sandy clay		
3302	Layer		2		Natural. light yellowish brown sandy gravels		
3303	Cut		0.86	0.18	Ditch		
3304	Fill	3303	0.86	0.08	Secondary Fill. Moderately compact mottled mid brownish grey silty sand.	Pot	Roman
3305	Fill	3303	0.55	0.03	Tertiary Fill. Moderately friable dark grey silty sand.		
3306	Fill	3303	0.68	0.07	Primary Fill. Moderately friable light yellow silty sand		

### Trench 34

General description					Orientation		E-W
Trench revealed one pit and one ditch. Trench consists of ploughsoil and subsoil overlying a sandy gravel natural.					Length (m)		30
					Width (m)		2
					Avg. depth (m)		0.25
Context No.	Type	Fill Of	Width (m)	Depth (m)	Description	Finds	Date
3400	Layer		2	0.22	Ploughsoil. Loose mid brownish grey sandy silt		

3401	Layer		2	0.06	Subsoil. mid yellowish brown sandy clay		
3402	Layer		2		Natural. light yellowish brown sandy gravels		
3403	Cut		0.4	0.08	Pit. Possible pit		
3404	Fill	3403	0.4	0.08	Primary Fill. Mottled mid to light grey, friable sand, no finds.		
3405	Cut		1.29	0.18	Ditch		
3406	Fill	3405	1.29	0.18	Primary Fill. Soft mid greyish brown sandy silt.		

### Trench 35

General description					Orientation		E-W
Trench revealed one ditch. Trench consists of ploughsoil and subsoil overlying a sandy gravel natural.					Length (m)		30
					Width (m)		2
					Avg. depth (m)		0.4

Context No.	Type	Fill Of	Width (m)	Depth (m)	Description	Finds	Date
3500	Layer		2	0.25	Ploughsoil. Loose mid brownish grey sandy silt.		
3501	Layer		2	0.15	Subsoil. firm mid yellowish brown sandy clay.		
3502	Layer		2		Natural. light yellowish brown sandy gravels.		
3503	Cut		0.5	0.14	Ditch		
3504	Fill	3503	0.5	0.14	Primary Fill. soft mid orange-brown silty sand.		

### Trench 36

General description					Orientation		
					Length (m)		
					Width (m)		
					Avg. depth (m)		

Context No.	Type	Fill Of	Width (m)	Depth (m)	Description	Finds	Date
-------------	------	---------	-----------	-----------	-------------	-------	------

### Trench 37

General description					Orientation		
					Length (m)		
					Width (m)		
					Avg. depth (m)		

Context No.	Type	Fill Of	Width (m)	Depth (m)	Description	Finds	Date
-------------	------	---------	-----------	-----------	-------------	-------	------

Trench 38							
General description					Orientation		
					Length (m)		
					Width (m)		
					Avg. depth (m)		
Context No.	Type	Fill Of	Width (m)	Depth (m)	Description	Finds	Date
<b>Trench 39</b>							
General description					Orientation		
					Length (m)		
					Width (m)		
					Avg. depth (m)		
Context No.	Type	Fill Of	Width (m)	Depth (m)	Description	Finds	Date
<b>Trench 40</b>							
General description					Orientation		E-W
Trench contains two pits. Trench consists of ploughsoil and subsoil overlying clay geology.					Length (m)		30
					Width (m)		2
					Avg. depth (m)		0.5
Context No.	Type	Fill Of	Width (m)	Depth (m)	Description	Finds	Date
4000	Layer			0.23	Ploughsoil. Mid brownish grey sandy clay.		
4001	Layer				Natural. Mid reddish brown sandy clay		
4002	Cut		0.8	0.22	Pit		
4003	Fill		0.8	0.22	Primary Fill. Mid greyish brown sandy clay with frequent charcoal inclusions on surface.		
4004	Cut		1.3	0.5	Pit		
4005	Layer			0.32	Subsoil. Soft, compact mid greyish brown sandy clay.	Flint	PH (res)
4006	Fill	4004	1.1	0.26	Secondary Fill. Mid greyish orange sandy clay with manganese inclusions.		
<b>Trench 41</b>							
General description					Orientation		
					Length (m)		
					Width (m)		
					Avg. depth (m)		

Context No.	Type	Fill Of	Width (m)	Depth (m)	Description	Finds	Date
<b>Trench 42</b>							
General description					Orientation		NW-SE
Trench revealed three possible pits. It consists of ploughsoil and subsoil overlying clay and gravel geology					Length (m)		30
					Width (m)		2.1
					Avg. depth (m)		0.5
Context No.	Type	Fill Of	Width (m)	Depth (m)	Description	Finds	Date
4200	Layer		0.3		Ploughsoil. Mid greyish brown Sandy clay		
4201	Layer			0.2	Subsoil. Mid orange-brown Sandy clay		
4202	Layer				Natural. Light orange-brown Sandy clay		
4203	Cut		0.32	0.06	Pit		
4204	Fill	4203	0.32	0.06	Secondary Fill. Soft Mid greyish brown Sandy clay	Flint	PH
4205	Cut		0.76	0.38	Pit		
4206	Fill	4205	0.76	0.38	Secondary Fill. Soft Mid greyish brown Silty clay	Pot	MBA-IA
4207	Cut		1	0.31	Ditch. Terminus		
4208	Fill	4207	0.98	0.15	Secondary Fill. Dark brownish grey sandy silt with frequent grit and gravels	Pot, animal bone	C13-15
4209	Fill	4207	0.22	0.02	Primary Fill. soft Light yellowish brown silty clay		
4210	Fill	4207	0.68	0.18	Secondary Fill. Light yellowish grey soft sandy silt.		
<b>Trench 43</b>							
General description					Orientation		NE-SW
Trench contains five postholes and a ditch. Trench consists of ploughsoil and subsoil overlying clay and gravel geology.					Length (m)		30
					Width (m)		2.1
					Avg. depth (m)		0.46
Context No.	Type	Fill Of	Width (m)	Depth (m)	Description	Finds	Date
4300	Layer			0.35	Ploughsoil. Mid greyish brown Sandy clay		
4301	Layer			0.11	Subsoil. Mid orange-brown Sandy clay		



4302	Layer				Natural. Light orange-brown Sandy clay		
4303	Cut		0.4	0.06	Posthole		
4304	Fill	4303	0.35	0.06	Secondary Fill. Mid greyish brown Soft Silty clay		
4305	Cut		0.3	0.1	Posthole		
4306	Fill	4305	0.3	0.1	Secondary Fill. Mid greyish brown Soft Silty clay		
4307	Cut		0.4	0.08	Posthole		
4308	Fill	4307	0.4	0.08	Secondary Fill. Mid greyish brown Soft Sandy clay		
4309	Cut		0.4	0.06	Posthole		
4310	Fill	4309	0.4	0.06	Secondary Fill. Mid greyish brown Very soft Silty clay		
4311	Cut		0.8	0.22	Ditch		
4312	Fill	4311	0.8	0.22	Secondary Fill. Mid greyish brown Moderate soft Silty clay	Animal bone	
4313	Cut		0.25	0.1	Posthole		
4314	Fill	4313	0.25	0.1	Secondary Fill. Mid greyish brown Soft Sandy clay		

#### Trench 44

General description	Orientation	N-S
Trench contains a terminus and two natural features. Trench consists of ploughsoil overlying clay natural.	Length (m)	30
	Width (m)	2
	Avg. depth (m)	0.3

Context No.	Type	Fill Of	Width (m)	Depth (m)	Description	Finds	Date
4400	Layer			0.32	Ploughsoil. Mid greyish brown silty clay.		
4401	Layer				Subsoil. Mid greyish brown silty sand		
4402	Layer				Natural. Brownish orange sandy clay natural		
4403	Cut		2.15	0.08	Natural Feature. Kidney shaped pit. Light brownish grey clayey silt.		
4404	Cut		1.36	0.15	Natural Feature. Light greyish brown clayey silt		
4405	Cut		0.56	0.22	Ditch. Terminus of NW/SE ditch.		

4406	Fill	4405	0.56	0.22	Primary Fill. Light brownish grey mod compact clayey silt	Pot, flint	MBA-IA
<b>Trench 45</b>							
General description					Orientation		
					Length (m)		
					Width (m)		
					Avg. depth (m)		
Context No.	Type	Fill Of	Width (m)	Depth (m)	Description	Finds	Date
<b>Trench 46</b>							
General description					Orientation		NW-SE
Trench contains two ditches, a pit and a natural feature. Trench consists of ploughsoil and subsoil overlying clay and gravel geology.					Length (m)		30
					Width (m)		2.1
					Avg. depth (m)		0.45
Context No.	Type	Fill Of	Width (m)	Depth (m)	Description	Finds	Date
4600	Layer			0.28	Ploughsoil. Mid greyish brown Sandy clay		
4601	Layer			0.17	Subsoil. Mid orange-brown Sandy clay		
4602	Layer				Natural. Light orange-brown Sandy clay		
4603	Cut		0.51	0.13	Ditch. N/S		
4604	Fill	4603	0.51	0.13	Primary Fill. Light brownish grey clayey silt		
4605	Cut		0.53	0.18	Ditch. N/S		
4606	Fill	4605	0.53	0.18	Primary Fill. Light brownish grey with freq. Charcoal inclusions. Clayey silt	Flint	
4607	Cut		0.47	0.08	Pit		
4608	Fill	4607	0.46	0.08	Primary Fill. Dark greyish brown clayey silt		
4609	Layer		0.6		Natural. Natural linear. Light reddish grey sandy silt		
<b>Trench 47</b>							
General description					Orientation		N-S
Trench contains two parallel ditches and a pit. Trench consists of ploughsoil and subsoil overlying clay and gravel geology.					Length (m)		30
					Width (m)		2.1
					Avg. depth (m)		0.5
Context No.	Type	Fill Of	Width (m)	Depth (m)	Description	Finds	Date

4700	Layer			0.3	Ploughsoil. Mid greyish brown Sandy clay		
4701	Layer			0.2	Subsoil. Mid orange-brown Sandy clay		
4702	Layer				Natural. Light orange-brown Sandy clay		
4703	Unexcavated feature		1.05		Pit. Sub ovular. Mid brownish grey sandy silt. Cut by 4706	CBM	PMed
4704	Cut		1.1	0.23	Ditch. NW/SE		
4705	Fill	4704	1.1	0.23	Primary Fill. Dark brownish grey clayey silt		
4706	Cut		1.07	0.22	Ditch. E/W		
4707	Fill	4706	1.07	0.22	Primary Fill. Mid brownish grey clayey silt		

#### Trench 48

General description

Orientation

E-W

Trench contains three natural features and a pit. Trench consists of ploughsoil overlying clay geology.

Length (m)

30

Width (m)

2

Avg. depth (m)

0.3

Context No.	Type	Fill Of	Width (m)	Depth (m)	Description	Finds	Date
4800	Layer			0.33	Ploughsoil. Mid greyish brown silty clay		
4801	Layer				Natural. Mid reddish brown sandy clay		
4802	Cut				Natural Feature. Irregular cut with roughly concave sides and base, both exhibit irregularities.		
4803	Cut				Natural Feature. Roughly sub circular cut with roughly concave sides and base, both exhibiting irregularities.		
4804	Cut		0.52	0.26	Pit. Sub-circular cut with moderately sloping concave sides and base.		
4805	Fill	4804	0.52	0.26	Secondary Fill. Moderately compact mid greyish brown silty clay with		

					occasional sub-angular stones. No finds.		
4806	Cut				Natural Feature. Interface between two naturals that have dragging top soil between them.		
4807	Cut		0.4	0.23	Natural Feature. Natural pit. Dark greyish sandy silt		

#### Trench 49

General description					Orientation		
					Length (m)		
					Width (m)		
					Avg. depth (m)		
Context No.	Type	Fill Of	Width (m)	Depth (m)	Description	Finds	Date

#### Trench 50

General description					Orientation		NNW-SSE
Trench contains a large tree bole feature. It consists of ploughsoil and subsoil overlying clay and sand geology.					Length (m)		30
					Width (m)		2.1
					Avg. depth (m)		0.66
Context No.	Type	Fill Of	Width (m)	Depth (m)	Description	Finds	Date
5000	Layer			0.33	Ploughsoil. Mid greyish brown Sandy clay		
5001	Layer			0.27	Subsoil. Mid orange-brown Silty clay		
5002	Layer				Natural. Light orange-brown Sandy clay Gravel inclusions		
5003	Cut				Natural Feature. Tree bole		

#### Trench 51

General description					Orientation		
Trench contains two ditches and a pit. Trench consists of ploughsoil and subsoil overlying clay and gravel geology.					Length (m)		30
					Width (m)		2.1
					Avg. depth (m)		0.6
Context No.	Type	Fill Of	Width (m)	Depth (m)	Description	Finds	Date
5100	Layer			0.35	Ploughsoil. Mid greyish brown Sandy clay		
5101	Layer			0.31	Subsoil. Mid orange-brown Silty clay		

5102	Layer				Natural. Light orange-brown Sandy clay Gravel inclusions		
5103	Unexcavated feature		1.34		Ditch. Dark brown/black clayey silt. Same as 6203		
5104	Cut		0.56	0.1	Ditch. N/S		
5105	Fill	5104	0.56	0.1	Primary Fill. Mod compact light grey sandy silt 2235/6		
5106	Cut	5106	2.98		Natural Feature. Light yellowish grey silty sand		

### Trench 52

General description					Orientation		NW-SE
Trench devoid of archaeology. Plough soil and subsoil overlaying natural.					Length (m)		30
					Width (m)		2.1
					Avg. depth (m)		0.55
Context No.	Type	Fill Of	Width (m)	Depth (m)	Description	Finds	Date
5200	Layer		2.1	0.3	Ploughsoil		
5201	Layer		2.1	0.15	Subsoil. Mid orangish brown silty clay with occasional sub-angular stones.		
5202	Layer		2.1	0.1	Natural. Mid brownish orange silty clay with patches of gravel.		

### Trench 53

General description					Orientation		E-W
Trench contains two natural features. Trench consists of ploughsoil and subsoil overlaying gravel and clay geology.					Length (m)		30
					Width (m)		2.1
					Avg. depth (m)		0.45
Context No.	Type	Fill Of	Width (m)	Depth (m)	Description	Finds	Date
5300	Layer		2.1	0.28	Ploughsoil		
5301	Layer		2.1	0.15	Subsoil. Mid orangish brown silty clay with occasional sub-angular stones.		
5302	Layer		2.1	0.02	Natural. Mid brownish orange silty clay with patches of mid brownish yellow silty sand and gravel.		

5303	Cut		1.83	0.36	Natural Feature. Sub-circular. Light grey/dark brown clayey sand		
5304	Layer		1.3		Natural. Dark reddish grey clayey silt		

#### Trench 54

General description					Orientation		
					Length (m)		
					Width (m)		
					Avg. depth (m)		
Context No.	Type	Fill Of	Width (m)	Depth (m)	Description	Finds	Date
5400	Void						
5401	Void						

#### Trench 55

General description					Orientation		E-W
Trench contains a ditch. Trench consists of ploughsoil and subsoil overlying clay geology.					Length (m)		30
					Width (m)		2
					Avg. depth (m)		0.5
Context No.	Type	Fill Of	Width (m)	Depth (m)	Description	Finds	Date
5500	Layer			0.35	Ploughsoil. Dark grey sandy silt topsoil		
5501	Layer			0.22	Subsoil. Dark reddish brown clayey silt subsoil		
5502	Layer				Natural. Orange-brown gravelly sandy clay natural		
5503	Cut		0.41	0.11	Ditch. N/S		
5504	Fill	5503	0.41	0.11	Primary Fill. Mod compact light grey sandy silt 2232/4		

#### Trench 56

General description					Orientation		NW-SE
Trench contains two ditches, a pit and a natural feature. Trench consists of ploughsoil and subsoil overlying clay and gravel geology.					Length (m)		30
					Width (m)		2.1
					Avg. depth (m)		0.69
Context No.	Type	Fill Of	Width (m)	Depth (m)	Description	Finds	Date
5600	Layer		2.1	0.3	Ploughsoil		
5601	Layer		2.1	0.3	Subsoil. Mid orangish brown silty clay with occasional sub-angular stones.		

5602	Layer		2.1	0.09	Natural. Mid brownish orange silty clay with patches of gravel.		
5603	Cut		0.96	0.3	Ditch. NE/SW		
5604	Fill	5603	0.96	0.3	Primary Fill. Mod compact light brownish grey clayey silt 2330/1		
5605	Cut		0.35	0.06	Natural Feature. Curvilinear. Light reddish grey clayey silt		
5606	Cut		1.05	0.13	Natural Feature. Ovular pit. Dark reddish brown sandy silt		
5607	Unexcavated feature		0.89		Ditch. NW/SE. Dark reddish brown clayey silt		

### Trench 57

General description					Orientation		NE-SW
Trench contains two natural features. Trench consists of ploughsoil and subsoil overlaying sand and clay geology.					Length (m)		30
					Width (m)		2.1
					Avg. depth (m)		0.6

Context No.	Type	Fill Of	Width (m)	Depth (m)	Description	Findings	Date
5700	Layer		2.1	0.4	Ploughsoil. Mid to dark grey-brown sandy silt.		
5701	Layer		2.1	0.18	Natural. Mid brownish orange silty clay with occasional sub-angular stones		
5702	Layer		2.1	0.02	Natural. Mid brownish orange silty clay with patches of mid brownish yellow silty sand and gravel.		
5703	Cut		1.02	0.26	Natural Feature. Nat pit. Dark brown clayey silt		
5704	Layer		0.31		Natural. Sub circular pit. Dark reddish brown clayey silt		

### Trench 58

General description					Orientation		NW-SE
					Length (m)		30
					Width (m)		2.1

Trench contains a ditch and three natural features. Trench consists of ploughsoil and subsoil overlying clay and sand geology.						Avg. depth (m)	0.5
Context No.	Type	Fill Of	Width (m)	Depth (m)	Description	Finds	Date
5800	Layer		2.1	0.3	Ploughsoil. Mid to dark grey-brown sandy silt.		
5801	Layer		2.1	0.15	Subsoil. Mid orangish brown silty clay with occasional sub-angular stones.		
5802	Layer		2.1	0.15	Natural. Mid brownish orange silty clay with occasional sub-angular stones.		
5803	Cut		0.84	0.28	Ditch. NE/SW		
5804	Fill	5803	0.84	0.28	Primary Fill. Dark greyish brown mod compact clayey silt		
5805	Cut	5805	1.84	0.12	Natural Feature. Natural pit. Light brownish grey clayey sand		
5806	Cut		0.76	0.16	Natural Feature. Light greyish brown clayey silt		
5807	Layer		1.61		Natural. Light brownish grey clayey silt		
5808	Void						
<b>Trench 59</b>							
General description					Orientation		
					Length (m)		
					Width (m)		
					Avg. depth (m)		
Context No.	Type	Fill Of	Width (m)	Depth (m)	Description	Finds	Date
<b>Trench 60</b>							
General description					Orientation		NE-SW
Trench contained five possible features that were investigated and determined to be of natural origin. It consists of ploughsoil, subsoil overlying clay and gravel geology.					Length (m)		30
					Width (m)		2.1
					Avg. depth (m)		0.5
Context No.	Type	Fill Of	Width (m)	Depth (m)	Description	Finds	Date
6000	Layer		2.1	0.3	Ploughsoil		
6001	Layer		2.1	0.1	Subsoil. Mid orangish brown silty clay with		



					occasional sub-angular stones.		
6002	Layer		2.1	0.1	Natural. Mid brownish orange silty clay with patches of gravel.		
6003	Cut		0.64	0.37	Natural Feature. Sub oval pit. Dark grey clayey silt		
6004	Cut		0.99	0.23	Natural Feature. Light brownish grey sandy silt		
6005	Cut		0.55	0.12	Natural Feature. Dark greyish brown sandy silt		
6006	Cut		2.32	0.16	Natural Feature. Crescent shaped pit. Light brownish grey clayey silt		
6007	Cut		1.74	0.24	Natural Feature. Kidney shaped hollow. Dark brownish grey sandy silt		

#### Trench 61

General description		Orientation	E-W
Trench contains four pits and two linears. Trench consists of ploughsoil and subsoil overlying clay and gravel geology.		Length (m)	30
		Width (m)	2.1
		Avg. depth (m)	0.65

Context No.	Type	Fill Of	Width (m)	Depth (m)	Description	Findings	Date
6100	Layer		2.1	0.35	Ploughsoil		
6101	Layer		2.1	0.2	Subsoil. Mid orangish brown silty clay with occasional sub-angular stones.		
6102	Layer		2.1	0.1	Natural. Mid brownish orange silty clay with patches of gravel		
6103	Cut		1.88	0.12	Ring Ditch. Aligns with crop marks. Only in section.		
6104	Fill	6103	1.88	0.12	Primary Fill. Dark brown-grey clay silt.	Pot, flint	ENeo?
6105	Cut		0.71	0.44	Natural Feature. Curvilinear. Natural feature		
6106	Fill	6105	0.71	0.44	Primary Fill. Light greyish brown clayey silt	Pot	MBA-IA
6107	Cut		0.81	0.21	Ditch. N/S. Probable terminus		

6108	Fill	6107	0.81	0.21	Primary Fill. Light brownish grey sandy silt	Flint	PH
6109	Cut		0.89	0.19	Ditch. N/S. Probable terminus		
6110	Fill	6109	0.89	0.19	Primary Fill. Light brownish grey sandy silt		
6111	Cut		1.86	0.17	Natural Feature. Natural feature. Light brownish grey sandy silt		
6112	Cut		0.32	0.04	Natural Feature. Circular natural feature. Dark greyish brown sandy silt		
6113	Unexcavated feature		0.85		Pit. Dark orangish brown clayey silt		
6114	Unexcavated feature		2.32		Pit. Light brownish grey sandy silt		
6115	Layer		3.3		Natural. Light grey-brown silty sand.		

### Trench 62

General description					Orientation		NE-SW
Trench contains a ditch and a ring ditch. Trench consists of ploughsoil and subsoil overlaying gravel and clay geology.					Length (m)		30
					Width (m)		2.1
					Avg. depth (m)		0.48

Context No.	Type	Fill Of	Width (m)	Depth (m)	Description	Finds	Date
6200	Layer		2.1	0.34	Ploughsoil. Mid to dark grey-brown, sandy silt		
6201	Layer		2.1	0.12	Subsoil. Mottled mid brownish orange and mid orangish brown silty clays with occasional sub-angular stones.		
6202	Layer		2.1	0.02	Natural. Mid brownish orange silty clay with occasional sub-angular stones		
6203	Cut		1.74	0.64	Ditch. N/S		
6204	Fill	6203		0.27	Primary Fill. Orangish brown sandy silt		
6205	Fill	6203	1.74	0.32	Secondary Fill. Dark brown-black with deposition of natural clayey silt	Flint, glass	PH (res), C19-20
6206	Cut		0.42	0.08	Pit. Sub circular		

6207	Fill	6206	0.42	0.08	Primary Fill. Dark brownish grey clayey silt		
6208	Cut		2.57	0.08	Ring Ditch. Aligns with crop marks. Only in section.		
6209	Fill	6208	2.57	0.08	Primary Fill. Dark greyish brown clayey silt with manganese inclusions. 2248/53		

### Trench 63

General description					Orientation		E-W
Trench contains a pit. Trench consists of ploughsoil and subsoil overlying sand and clay geology.					Length (m)		30
					Width (m)		2
					Avg. depth (m)		0.45

Context No.	Type	Fill Of	Width (m)	Depth (m)	Description	Finds	Date
6300	Layer			0.3	Ploughsoil. Mid brown clay silt.		
6301	Layer			0.1	Subsoil. Mid red-brown clay silt.		
6302	Layer				Natural. Mid red-brown silt clay.		
6303	Cut		0.53	0.19	Pit. Sub circular		
6304	Fill	6303	0.53	0.19	Deliberate Backfill. Light greyish brown mod compact clayey silt		

### Trench 64

General description					Orientation		
					Length (m)		
					Width (m)		
					Avg. depth (m)		

Context No.	Type	Fill Of	Width (m)	Depth (m)	Description	Finds	Date
-------------	------	---------	-----------	-----------	-------------	-------	------

### Trench 65

General description					Orientation		NW-SE
Trench contains a natural feature. Trench consists of ploughsoil and subsoil overlying clay geology.					Length (m)		30
					Width (m)		2
					Avg. depth (m)		0.25

Context No.	Type	Fill Of	Width (m)	Depth (m)	Description	Finds	Date
6500	Layer			0.27	Ploughsoil. Firm mid greyish brown sandy clay.		
6501	Layer				Natural. Mid reddish brown sandy clay		

6502	Cut		2.67	0.07	Natural Feature. Light brownish grey silty sand		
<b>Trench 66</b>							
General description					Orientation		E-W
Trench contains two ditches. Trench consists of ploughsoil overlying sand and clay geology.					Length (m)		30
					Width (m)		2.1
					Avg. depth (m)		0.45
Context No.	Type	Fill Of	Width (m)	Depth (m)	Description	Finds	Date
6600	Layer		2.1	0.3	Ploughsoil. Dark grey-brown silty sand.		
6601	Layer		2.1	0.15	Natural. Reddish orange silty sand with patches of gravel.		
6602	Cut		0.82	0.24	Ditch		
6603	Fill		0.82	0.24	Primary Fill. Soft, loose mid brownish grey clayey sand.		
6604	Cut		0.7	0.18	Ditch		
6605	Fill	6604	0.7	0.18	Primary Fill. Soft, loose mid greyish brown clayey sand.		
6606	Fill	6602		0.19	Secondary Fill. Mid brown silt gravel.		
<b>Trench 67</b>							
General description					Orientation		
					Length (m)		
					Width (m)		
					Avg. depth (m)		
Context No.	Type	Fill Of	Width (m)	Depth (m)	Description	Finds	Date
<b>Trench 68</b>							
General description					Orientation		NE-SW
Trench contains one ditch. Trench consists of ploughsoil overlying sand geology.					Length (m)		28
					Width (m)		2.1
					Avg. depth (m)		0.54
Context No.	Type	Fill Of	Width (m)	Depth (m)	Description	Finds	Date
6800	Layer		2.1	0.3	Ploughsoil		
6801	Layer		2.1	0.14	Natural. Mid yellowish brown silty clay with occasional sub-angular stones.		
6802	Cut		1.28	0.32	Ditch		
6803	Fill	6802	1.28	0.32	Deliberate Backfill		

6804	Fill	6802	0.62	0.18	Deliberate Backfill	Fe	PMed/ Mod
<b>Trench 69</b>							
General description					Orientation		E-W
Trench contains a pit. Trench consists of ploughsoil and subsoil overlying clay geology.					Length (m)		30
					Width (m)		2
					Avg. depth (m)		0.5
Context No.	Type	Fill Of	Width (m)	Depth (m)	Description	Finds	Date
6900	Layer			0.3	Ploughsoil. Dark greyish brown slightly sandy silt	Flint	PH (res)
6901	Layer			0.2	Subsoil. Brown sandy clayey silt.		
6902	Layer				Natural. Strong brown clayey sandy silt. Brick earth.		
6903	Cut		1.85	0.32	Pit		
6904	Fill	6903	1.85	0.32	Primary Fill. Compact mid greyish brown clayey sand with frequent charcoal inclusions.	Flint	PH
<b>Trench 70</b>							
General description					Orientation		NE-SW
Trench contains one pit and four natural features. Trench consists of ploughsoil and subsoil overlying sand geology.					Length (m)		30
					Width (m)		2
					Avg. depth (m)		0.5
Context No.	Type	Fill Of	Width (m)	Depth (m)	Description	Finds	Date
7000	Layer			0.33	Ploughsoil. Mid-greyish brown silt, few pebbles		
7001	Layer			0.12	Subsoil. Brown slightly sandy silt. Subsoil from brickearth		
7002	Layer			0.05	Natural. Yellow slightly clayey sand, with gravel lenses		
7003	Cut		0.53	0.12	Natural Feature. Light greyish orange. Sandy clay. Compact. Very occasional sub angled stones.		
7004	Cut		1	0.15	Natural Feature. Light greyish orange. Sandy clay. Compact.		

					Occasional small rounded stones.		
7005	Cut		1.08	0.3	Pit		
7006	Fill	7005	1.08	0.3	Primary Fill		
7007	Cut		1.12	0.19	Natural Feature. Med orangish brown. Clay sand. Soft. Occasional rooting action.		
7008	Cut		0.45	0.18	Natural Feature. Mid greyish brown. Sandy, silty clay. Compact. Occasional sub angled stones.		

### Trench 71

General description					Orientation		SE-NW
Trench contains one ditch. Trench consists of ploughsoil overlying clay geology.					Length (m)		30
					Width (m)		2
					Avg. depth (m)		0.6

Context No.	Type	Fill Of	Width (m)	Depth (m)	Description	Finds	Date
7100	Layer				Ploughsoil. Mid greyish brown sandy clay		
7101	Layer				Natural. Mid reddish brown sandy clay		
7102	Fill		2.22	0.42	Secondary Fill. Grey-brown sandy silt.	Pot, flint	IA?
7103	Cut		2.22	0.42	Pit		

### Trench 72

General description					Orientation		E-W
Trench contains one linear and two pits. Trench consists of ploughsoil and subsoil overlying clay and gravel geology.					Length (m)		30
					Width (m)		2
					Avg. depth (m)		0.5

Context No.	Type	Fill Of	Width (m)	Depth (m)	Description	Finds	Date
7200	Layer			0.3	Ploughsoil. Dark greyish brown silt		
7201	Layer			0.2	Subsoil. Yellowish brown slightly sandy silt. Subsoil from brickearth		
7202	Layer				Natural. Light yellow slightly clayey sand with lenses of gravel. Pleistocene river terrace		
7203	Cut		0.7	0.12	Pit		

7204	Fill	7203	0.7	0.12	Deliberate Backfill. Dark grey-brown silt clay.		
7205	Cut		0.73	0.24	Ditch		
7206	Fill	7205	0.73	0.24	Primary Fill. Soft mid orange-brown sandy silt with no inclusions	Pot, flint, animal bone	ENeo or MBA-IA
7207	Cut		1.9	0.42	Pit. base not reached due to 1m LOE		
7208	Fill	7207	0.38	0.3	Primary Fill. Loose mid orange pink sandy gravel		
7209	Fill	7207	0.42	0.08	Secondary Fill. Compact, light greyish pink silty clay with small gravel inclusions		
7210	Fill	7207	1.88	0.21	Secondary Fill. Compact, mid grey-pink sandy silt with rare, rounded pebbles.		
7211	Fill	7207	1.32	0.22	Secondary Fill. Moderately compact light yellow-pink silty sand.		

### Trench 73

General description					Orientation		NW-SE
Trench contains three ditches and two pits. Trench consists of ploughsoil and subsoil overlaying clay and gravel geology.					Length (m)		25
					Width (m)		2.1
					Avg. depth (m)		0.52
Context No.	Type	Fill Of	Width (m)	Depth (m)	Description	Finds	Date
7300	Layer		2.1	0.26	Ploughsoil. Mid grey-brown clay silt.		
7301	Layer		2.1	0.24	Subsoil. Mid yellowish brown silty clay with occasional sub-angular stones.		
7302	Layer		2.1	0.02	Natural. Mid orangish brown silty clay mottled with patches of light brownish yellow sand and gravel.		
7303	Cut		0.76	0.35	Pit		
7304	Fill	7303	0.76	0.35	Deliberate Backfill. Dark grey-brown clay silt.		
7305	Cut		0.44	0.29	Ditch		

7306	Fill	7305	0.44	0.29	Primary Fill. Mid grey-brown silt clay.		
7307	Cut		2.22	0.25	Ditch		
7308	Fill	7307	2.22	0.25	Primary Fill. Mid grey-brown silt clay.		
7309	Cut		0.25	0.23	Pit		
7310	Fill	7309	0.25	0.23	Deliberate Backfill. Mid brown-grey silt clay.		
7311	Cut		0.85	0.29	Ditch		
7312	Fill	7311	0.85	0.29	Primary Fill. Dark grey-brown silt clay.	Pot	AD 1–150

#### Trench 74

General description	Orientation	SE-NW
Trench contains a single pit. Trench consists of ploughsoil and subsoil overlying clay geology.	Length (m)	30
	Width (m)	2
	Avg. depth (m)	0.45

Context No.	Type	Fill Of	Width (m)	Depth (m)	Description	Finds	Date
7400	Layer			0.3	Ploughsoil. Greyish brown slightly sandy silt		
7401	Layer			0.1	Subsoil. Brown slightly sandy silt		
7402	Layer				Natural. Mid orangish brown, silty clay, firm		
7403	Cut		1	0.16	Pit		
7404	Fill	7403	1	0.16	Deliberate Backfill. Dark grey-brown silt clay.		

#### Trench 75

General description	Orientation	SE-NW
Trench contains two pits. Trench consists of ploughsoil and subsoil overlying sand and clay geology.	Length (m)	30
	Width (m)	2
	Avg. depth (m)	0.55

Context No.	Type	Fill Of	Width (m)	Depth (m)	Description	Finds	Date
7500	Layer			0.35	Ploughsoil. Dark brownish grey slightly sandy silt.		
7501	Layer			0.2	Subsoil. Brown slightly sandy silt. Subsoil from brickearth		
7502	Layer				Natural. Strong brown clayey silty sand with lenses of		



					gravel. Interface of brick earth to gravelly sand		
7503	Cut		1.1	0.21	Pit		
7504	Fill	7503	1.1	0.21	Primary Fill. Soft mid greyish brown clayey sand.		
7505	Cut		1.48	0.32	Pit. Edge of pit disappears into NW bulk.		
7506	Fill	7505	1.48	0.32	Primary Fill. Compact light reddish brown sandy clay	Flint	PH

### Trench 76

General description					Orientation		NE-SW
Trench contains a posthole, a pit, two ditches and a natural feature. Trench consists of ploughsoil and subsoil overlying sand and clay geology.					Length (m)		30
					Width (m)		2
					Avg. depth (m)		0.6
Context No.	Type	Fill Of	Width (m)	Depth (m)	Description	Finds	Date
7600	Layer			0.3	Ploughsoil. Dark grey-brown sandy silt		
7601	Layer			0.2	Subsoil. Mid reddish brown, clay sandy silt		
7602	Layer				Natural. Mixed silty clay and gravels.		
7603	Cut		2.24		Pit. Not bottomed		
7604	Fill	7603	0.94	0.3	Deliberate Backfill. Friable dark grey silty sand	Pot, flint	AD 400 – 750, AD 170–230 (res)
7605	Fill	7603	1.4	0.28	Primary Fill. Moderately friable light greyish yellow silty sand	Pot, flint	Roman, PH (res)
7606	Fill	7615	1.9	0.24	Primary Fill. Friable mid greyish yellow silty sand	Pot, CBM	Roman
7607	Cut				Natural Feature. Mid brownish red silty clay, compact		
7608	Cut		0.44	0.12	Ditch. Gully		
7609	Fill	7608	0.44	0.12	Primary Fill. Friable mid greyish brown silty sand		
7610	Cut		0.34	0.14	Ditch. Gully		
7611	Fill		0.34	0.14	Primary Fill. Friable mid greyish brown silty sand		
7612	Cut		0.26	0.1	Posthole. Possible posthole		

7613	Fill	7612	0.26	0.1	Primary Fill. Friable mid greyish brown silty sand		
7614	Cut		0.94	0.3	Pit. Double number of 7603. It is the same feature.		
7615	Cut		1.3	0.24	Pit		

### Trench 77

General description					Orientation		NE-SW
Trench consists of ploughsoil with subsoil overlying sand clay geology.					Length (m)		30
					Width (m)		2
					Avg. depth (m)		0.5
Context No.	Type	Fill Of	Width (m)	Depth (m)	Description	Finds	Date
7700	Layer			0.3	Ploughsoil. Mid brown clay silt.		
7701	Layer			0.15	Subsoil. Mid brown silt sand.		
7702	Layer				Natural. Light red-brown silt clay.		
7703	Cut		1.19	0.07	Natural Feature. Natural pit. Sub ovular. Dark reddish brown clayey silt		
7704	Layer		3.08		Natural. Sub circular pit. Light reddish brown clayey silt.	Pot	MBA-IA

### Trench 78

General description					Orientation		N-S
Trench consists of two ditches and a pit. Trench consists of ploughsoil overlying clay and gravel geology.					Length (m)		30
					Width (m)		2.1
					Avg. depth (m)		0.4
Context No.	Type	Fill Of	Width (m)	Depth (m)	Description	Finds	Date
7800	Layer			0.3	Ploughsoil. Dark grey-brown clay silt.		
7801	Layer			0.1	Natural. Mid brownish orange silty clay with occasional patches of gravel.		
7802	Cut		1.9	0.45	Ditch		
7803	Fill		1.4	0.45	Primary Fill. Mid grey-brown clay silt.	Pot	Roman
7804	Cut		0.8	0.35	Pit		
7805	Fill	7804	0.8	0.35	Primary Fill. Firm, dark greyish brown silty clay		

7806	Cut		0.3	0.12	Ditch		
7807	Fill	7806	0.3	0.12	Primary Fill. Soft, mid greyish brown silty clay		
7808	Fill	7802	0.7	0.3	Primary Fill. Firm, light yellowish grey silty clay		
7809	Fill	7802	0.55	0.45	Primary Fill. Firm, mid orange-brown silty clay		
7810	Fill	7804	0.45	0.3	Primary Fill. Firm, mid orange-brown silty clay		
7811	Cut		1.8	0.45	Natural Feature. Possible Natural Hollow running E-W through trench - fill consists of a soft, light greyish brown silty clay with gravel inclusion.		

#### Trench 79

General description		Orientation	E-W
Trench devoid of archaeology. Consists of ploughsoil overlaying natural.		Length (m)	30
		Width (m)	2.1
		Avg. depth (m)	0.3

Context No.	Type	Fill Of	Width (m)	Depth (m)	Description	Finds	Date
7900	Layer		2.1	0.34	Ploughsoil. Dark grey-brown sandy silt.		
7901	Layer		2.1	0.14	Natural. Mixed gravels		

#### Trench 80

General description		Orientation	SE-NW
Trench devoid of archaeology. Trench consists of ploughsoil and subsoil overlying clay geology.		Length (m)	30
		Width (m)	2
		Avg. depth (m)	0.5

Context No.	Type	Fill Of	Width (m)	Depth (m)	Description	Finds	Date
8000	Layer			0.3	Ploughsoil. Mid brown clay silt.		
8001	Layer			0.1	Subsoil. Mid red-brown clay silt.		
8002	Layer				Natural. Light brown-red silt clay.		

#### Trench 81

General description		Orientation	NE-SW
Probable tree throw at centre. Plough soil overlaying natural.		Length (m)	30

						Width (m)	2.1
						Avg. depth (m)	0.48
Context No.	Type	Fill Of	Width (m)	Depth (m)	Description	Finds	Date
8100	Layer		2.1	0.35	Ploughsoil. Dark grey-brown sandy silt		
8101	Layer		2.1	0.18	Natural. Mid orangish brown silty clay with occasional sub-angular stones.		
<b>Trench 82</b>							
General description						Orientation	E-W
Trench contains a single posthole. Trench consists of ploughsoil over clay sand geology.						Length (m)	30
						Width (m)	2
						Avg. depth (m)	0.5
Context No.	Type	Fill Of	Width (m)	Depth (m)	Description	Finds	Date
8200	Layer			0.45	Ploughsoil. Mid brown clay silt		
8201	Layer				Natural. Mid red-brown clayey sand		
8202	Cut		0.58	0.38	Posthole		
8203	Fill	8206	0.22	0.14	Deliberate Backfill. Mid greenish grey silty clay		
8204	Fill	8202	0.32	0.38	Primary Fill. Dark brownish grey sandy clay		
8205	Fill	8202	0.2	0.33	Secondary Fill. Mid brownish grey sandy clay		
8206	Cut		0.22	0.14	Posthole		
<b>Trench 83</b>							
General description						Orientation	N-S
Trench contains two ditches and a pit. Trench consists of ploughsoil over clay and sand geology.						Length (m)	25
						Width (m)	2
						Avg. depth (m)	0.47
Context No.	Type	Fill Of	Width (m)	Depth (m)	Description	Finds	Date
8300	Layer			0.4	Ploughsoil. Mid brown clay silt		
8301	Layer				Natural. Mid red-brown clay sand		
8302	Cut		2.1	0.3	Ditch		
8303	Fill	8302	1.9	0.18	Primary Fill. Moderately compact mid orange grey silty clay		
8304	Fill	8302	1.5	0.2	Secondary Fill. Moderately	Pot	Roman

					compact mid greyish brown silty clay		
8305	Cut		0.7	0.2	Ditch		
8306	Fill	8305	0.7	0.2	Primary Fill. Moderately compact mid orange grey silty clay	Pot	UD
8307	Cut		3.4	0.42	Pit. Possible pit		
8308	Fill	8307	3.4	0.42	Primary Fill. Moderately compact mid greyish brown silty clay		
<b>Trench 84</b>							
General description					Orientation		E-W
Trench contains a ditch and a natural feature. Trench consists of ploughsoil overlying clay geology.					Length (m)		30
					Width (m)		2
					Avg. depth (m)		0.4
Context No.	Type	Fill Of	Width (m)	Depth (m)	Description	Finds	Date
8400	Layer			0.35	Ploughsoil. Mid brown clay silt.		
8401	Layer				Natural. Mid yellowish brown sand silt.		
8402	Cut		1.92	0.52	Natural Feature. Sub-circular cut with moderately sloping concave sides and base. Both sides and base have irregularities.		
8403	Fill	8402	1.92	0.52	Primary Fill. Moderately compact mid greyish brown silty clay with occasional sub-angular stones. Bioturbation throughout.		
8404	Cut			0.07	Ditch		
8405	Fill	8404		0.07	Primary Fill. Dark orangish grey, silty clay, occasional small subangular stones		
8406	Cut		2.38	0.7	Ditch. Linear ditch running NW-SE with moderately sloping convex sides and a concave base.		

8407	Fill	8406	2.38	0.6	Deliberate Backfill. Moderately compact mid greyish brown silty clay with occasional sub-angular stones, charcoal and CBM flecks.		
8408	Fill	8406	1.08	0.08	Deliberate Backfill. Moderately compact mottled mid greyish brown silty clay with mid brownish orange silty sand with occasional sub-angular stones, charcoal and CBM flecks.		

### Trench 85

General description					Orientation	N-S	
Trench contains a ditch and a pit. Trench consists of ploughsoil over clay sand natural.					Length (m)	25	
					Width (m)	2	
					Avg. depth (m)	0.49	
Context No.	Type	Fill Of	Width (m)	Depth (m)	Description	Finds	Date
8500	Layer			0.45	Ploughsoil. Mid brown clay silt		
8501	Layer				Natural. Mid red-brown clay sand		
8502	Cut		0.57	0.16	Ditch		
8503	Fill	8502	0.57	0.16	Primary Fill. Dark grey-brown silt clay.		
8504	Cut		0.79	0.16	Pit		
8505	Fill	8504	0.79	0.16	Primary Fill. Mid grey-brown silt clay.		

### Trench 86

General description					Orientation	E-W	
Trench contains a ditch. Trench consists of ploughsoil over clay sand natural.					Length (m)	30	
					Width (m)	2	
					Avg. depth (m)	0.48	
Context No.	Type	Fill Of	Width (m)	Depth (m)	Description	Finds	Date
8600	Layer			0.48	Ploughsoil. Mid brown clay silt.		
8601	Layer				Natural. Mid red-brown clay sand		
8602	Cut		0.53	0.15	Ditch		

8603	Fill	8602	0.53	0.15	Primary Fill. Mid grey-brown silt clay.		
<b>Trench 87</b>							
General description					Orientation		N-S
Trench contains two natural features. Trench consists of ploughsoil over clay sand geology.					Length (m)		30
					Width (m)		2
					Avg. depth (m)		0.49
Context No.	Type	Fill Of	Width (m)	Depth (m)	Description	Finds	Date
8700	Layer			0.5	Ploughsoil. Mid brown clay silt		
8701	Layer				Natural. Mid red-brown clay sand		
8702	Cut				Natural Feature. Mid orange-brown silty clay.		
8703	Cut				Natural Feature. Tree-throw hole. 2 pieces of flint within fill. Mid reddish grey silty clay.	Flint	PH
<b>Trench 88</b>							
General description					Orientation		E-W
Trench contains a pit. Trench consists of ploughsoil over clay sand natural.					Length (m)		30
					Width (m)		2
					Avg. depth (m)		0.49
Context No.	Type	Fill Of	Width (m)	Depth (m)	Description	Finds	Date
8800	Layer			0.44	Ploughsoil. Mid brown clay silt	Flint	PH (res)
8801	Layer				Natural. Mid red-brown clay sand		
8802	Cut		1.14	0.45	Pit		
8803	Fill	8802		0.26	Secondary Fill. Mid grey-brown clay silt.	Pot, flint	ENeo
8804	Fill	8802		0.43	Secondary Fill. Mid brown-grey clay silt.	Pot, flint	ENeo
<b>Trench 89</b>							
General description					Orientation		NE-SW
Trench contains one ditch. Trench consists of ploughsoil overlying clay geology.					Length (m)		30
					Width (m)		2.1
					Avg. depth (m)		0.53
Context No.	Type	Fill Of	Width (m)	Depth (m)	Description	Finds	Date
8900	Layer		2.1	0.3	Ploughsoil		
8901	Layer		2.1	0.12	Natural. Mid orangish brown		

					silty clay with occasional sub-angular stones.		
8902	Cut				Ditch		
8903	Fill	8902			Primary Fill. Mid brownish grey sandy clay	Pot, CBM, stone	AD 1000 –1225, Roman (res)
<b>Trench 90</b>							
General description					Orientation		NW-SE
Trench contains one ditch. Trench consists of ploughsoil overlaying clay geology.					Length (m)		30
					Width (m)		2.1
					Avg. depth (m)		0.47
Context No.	Type	Fill Of	Width (m)	Depth (m)	Description	Finds	Date
9000	Layer		2.1	0.3	Topsoil. Plough soil		
9001	Layer		2.1	0.2	Natural. Mid reddish brown silty clay with occasional sub-angular stones.		
9002	Cut		1.44	0.13	Ditch		
9003	Fill	9002	1.44	0.13	Primary Fill. Dark grey-brown silty clay		
<b>Trench 91</b>							
General description					Orientation		E-W
Trench devoid of archaeology. Trench consists of ploughsoil over clay sand natural.					Length (m)		30
					Width (m)		2
					Avg. depth (m)		0.35
Context No.	Type	Fill Of	Width (m)	Depth (m)	Description	Finds	Date
9100	Layer			0.35	Ploughsoil. Mid brown clay silt		
9101	Layer				Natural. Mid red-brown clay sand		
<b>Trench 92</b>							
General description					Orientation		N-S
Trench contains a ditch and a tree throw. Trench consists of ploughsoil over clay sand geology.					Length (m)		30
					Width (m)		2
					Avg. depth (m)		0.35
Context No.	Type	Fill Of	Width (m)	Depth (m)	Description	Finds	Date
9200	Layer			0.35	Ploughsoil. Mid brown clay silt		
9201	Layer				Natural. Mid red-brown clay sand		
9202	Cut		0.73	0.22	Ditch		



9203	Fill	9202	0.73	0.22	Primary Fill. Mid grey-brown clay silt.		
9204	Layer		0.25	0.1	Other Layer. Dark grey-brown silt.		
9205	Unexcavated feature		3.5		Tree Throw. Light grey-brown clay silt.		

### Trench 93

General description	Orientation	E-W
Trench contains two pits and a ditch. Trench consists of ploughsoil overlying clay geology.	Length (m)	30
	Width (m)	2
	Avg. depth (m)	0.4

Context No.	Type	Fill Of	Width (m)	Depth (m)	Description	Finds	Date
9300	Layer			0.35	Ploughsoil. Mid brown clay silt.		
9301	Layer				Natural. Mid yellowish brown sand clay.		
9302	Cut		0.65	0.36	Pit		
9303	Fill	9302	0.65	0.36	Secondary Fill. Mid red-brown silt sand.	Pot, flint	MBA-IA
9304	Cut		1	0.46	Pit		
9305	Fill	9304	1	0.46	Secondary Fill. Mid greyish brown Silty clay Firm		
9306	Fill	9304			Secondary Fill. Not shown on section. Mid yellowish brown Very compact Sandy clay		
9307	Cut		1.85	0.6	Ditch		
9308	Fill	9307	1.85	0.6	Secondary Fill. Mid greyish brown Silty clay Very compact	Pot	Roman

### Trench 94

General description	Orientation	N-S
Trench devoid of archaeology. Consists of ploughsoil overlying clay geology.	Length (m)	30
	Width (m)	2
	Avg. depth (m)	0.4

Context No.	Type	Fill Of	Width (m)	Depth (m)	Description	Finds	Date
9400	Layer			0.35	Ploughsoil. Mid brown clay silt.		
9401	Layer				Natural. Mid red-brown clay sand.		

### Trench 95

General description	Orientation	E-W
	Length (m)	30

Trench contains a ditch. Trench consists of ploughsoil overlying clay geology.					Width (m)	2	
					Avg. depth (m)	0.4	
Context No.	Type	Fill Of	Width (m)	Depth (m)	Description	Finds	Date
9500	Layer			0.35	Ploughsoil. Mid brown clay silt.		
9501	Layer				Natural. Mid red-brown silt clay.		
9502	Cut		1.75	0.32	Ditch		
9503	Fill	9502	1.75	0.32	Primary Fill. Dark grey-brown silt clay.		

### Trench 96

General description					Orientation	N-S	
Trench contains two natural features, a tree throw, a pit and a ditch. Trench consists of ploughsoil and subsoil overlying clay and sand geology.					Length (m)	30	
					Width (m)	2	
					Avg. depth (m)	0.7	
Context No.	Type	Fill Of	Width (m)	Depth (m)	Description	Finds	Date
9600	Layer			0.3	Ploughsoil. Mid brown clay silt.	Flint	PH (res)
9601	Layer			0.35	Subsoil. Light brown clay sand.		
9602	Layer				Natural. Light yellowish brown clay sand gravel.		
9603	Cut		0.68	0.18	Pit		
9604	Fill	9603	0.68	0.18	Tertiary Fill. Mid brown yellow silty sand.		
9605	Cut		0.86	0.24	Natural Feature		
9606	Layer				Natural		
9607	Cut		1.1	0.64	Ditch		
9608	Fill	9607	1.1	0.64	Secondary Fill. Backfill containing small amounts of burning remains, pot and flint	Pot, flint	LBA/IA?
9609	Cut		1.5	0.41	Tree Throw. Tree throw containing small amount of pot		
9610	Fill	9609	0.62	0.23	Secondary Fill. Initial silting. Compact white brown sandy silt	Pot	ENeo or MBA-IA
9611	Fill	9609	1.5	0.39	Tertiary Fill. Final silting phase. Mid brown clayey silt.		
9612	Cut	9612			Natural Feature		

### Trench 97

General description					Orientation	N-S
					Length (m)	30

Trench devoid of archaeology. Trench consists of ploughsoil overlying clay geology.					Width (m)		2
					Avg. depth (m)		0.5
Context No.	Type	Fill Of	Width (m)	Depth (m)	Description	Finds	Date
9700	Layer			0.45	Ploughsoil. Mid brown clay silt.		
9701	Layer				Natural. Mid red-brown silt clay.		
<b>Trench 98</b>							
General description					Orientation		SE-NW
Trench contains one ditch terminus and two pits. Trench consists of ploughsoil overlying clay geology.					Length (m)		30
					Width (m)		2
					Avg. depth (m)		0.5
Context No.	Type	Fill Of	Width (m)	Depth (m)	Description	Finds	Date
9800	Layer			0.45	Ploughsoil. Mid brown clay silt.		
9801	Layer				Natural. Light yellowish brown sand clay.		
9802	Cut		0.88	0.24	Ditch		
9803	Fill	9802	0.88	0.24	Primary Fill. Mid orange-brown sand clay.	Flint	PH
9804	Cut		1	0.42	Pit		
9805	Fill	9804	1	0.42	Primary Fill. Soft, mid greyish brown, sandy clay.	Pot, flint	MBA-IA
9806	Cut		1.02	0.3	Pit		
9807	Fill	9806	1.02	0.3	Primary Fill. Soft, mid greyish brown, sandy clay.		
<b>Trench 99</b>							
General description					Orientation		N-S
Trench contains a posthole and a natural feature. Trench consists of ploughsoil over clay sand natural.					Length (m)		30
					Width (m)		2
					Avg. depth (m)		0.5
Context No.	Type	Fill Of	Width (m)	Depth (m)	Description	Finds	Date
9900	Layer			0.45	Ploughsoil. Mid brown clay silt		
9901	Layer				Natural. Mid red-brown clay sand		
9902	Cut		0.19	0.11	Posthole		
9903	Fill	9902	0.19	0.11	Primary Fill. Mid grey-brown sand clay.		
9904	Cut		0.5	0.12	Natural Feature. Tree throw. Mid greyish brown fill. No finds.		

<b>Trench 100</b>							
General description					Orientation		E-W
Trench contains one ditch and one natural feature. Trench consists of ploughsoil overlying clay geology.					Length (m)		30
					Width (m)		2
					Avg. depth (m)		0.45
Context No.	Type	Fill Of	Width (m)	Depth (m)	Description	Finds	Date
10000	Layer			0.4	Ploughsoil. Mid brown clay silt.		
10001	Layer				Natural. Mid red-brown silt clay.		
10002	Cut		0.98		Natural Feature		
10003	Cut		0.77	0.3	Ditch. Possibly prehistoric ditch running SE-NW		
10004	Fill	10003	0.77	0.3	Secondary Fill. Mid blackish brown sandy silt	Pot, flint	MBA-IA
<b>Trench 101</b>							
General description					Orientation		N-S
Trench devoid of archaeology. Trench consists of ploughsoil overlying clay geology.					Length (m)		30
					Width (m)		2
					Avg. depth (m)		0.4
Context No.	Type	Fill Of	Width (m)	Depth (m)	Description	Finds	Date
10100	Layer			0.35	Ploughsoil. Mid brown clay silt.		
10101	Layer				Natural. Mid yellowish brown sand silt.		
<b>Trench 102</b>							
General description					Orientation		E-W
Trench contains one pit. Trench consists of ploughsoil overlying clay geology.					Length (m)		30
					Width (m)		2
					Avg. depth (m)		0.4
Context No.	Type	Fill Of	Width (m)	Depth (m)	Description	Finds	Date
10200	Layer			0.35	Ploughsoil. Mid brown clay silt.		
10201	Layer				Natural. Mid yellowish brown silt clay.		
10202	Cut		0.72		Natural Feature		
10203	Cut		0.9	0.18	Pit. Fire pit		
10204	Fill	10203		0.1	Primary Fill. Moderately compact mid yellowish grey silty clay		

10205	Fill	10203		0.14	Secondary Fill. Scorched. Moderately compact mixed orange red silty clay.	Pot	IA?
-------	------	-------	--	------	---------------------------------------------------------------------------	-----	-----

### Trench 103

General description	Orientation	N-S
Trench contains a ditch, a pit and a natural feature. Trench consists of ploughsoil overlying clay geology.	Length (m)	30
	Width (m)	2
	Avg. depth (m)	0.4

Context No.	Type	Fill Of	Width (m)	Depth (m)	Description	Finds	Date
10300	Layer			0.35	Ploughsoil. Mid brown clay silt.		
10301	Layer				Natural. Mid red-brown silt sand clay.		
10302	Cut		1.3	0.22	Pit		
10303	Fill	10302	1.3	0.22	Primary Fill. Dark grey-brown silt clay.		
10304	Cut				Natural Feature. Tree-throw hole/rooting		
10305	Cut		1.5	0.16	Ditch		
10306	Fill	10305	1.5	0.16	Primary Fill. Mid grey-brown silt sand.		
10307	Cut		1.9	0.3	Ditch		
10308	Fill	10307	1.4	0.1	Primary Fill. Compact mottled grey silty clay.		
10309	Fill	10307	1.9	0.26	Secondary Fill. Moderately compact mid orange-grey silty clay		

### Trench 104

General description	Orientation	SE-NW
Trench contains two pits, a terminus and a ditch. Trench consists of ploughsoil overlying clay geology.	Length (m)	30
	Width (m)	2
	Avg. depth (m)	0.5

Context No.	Type	Fill Of	Width (m)	Depth (m)	Description	Finds	Date
10400	Layer			0.25	Ploughsoil. Mid brown clay silt.	Flint	PH (res)
10401	Layer			0.15	Subsoil. Mid red-brown silt clay.		
10402	Layer				Natural. Mid brown-yellow sand clay.	Pot	AD 1270 -1350

10403	Cut		1.76	0.2	Natural Feature. Mid reddish grey sandy clay	Pot, animal bone	Roman
10404	Cut		1.89	0.32	Pit		
10405	Fill	10404	1.89	0.32	Primary Fill. Mid brownish grey sandy clay	Pot, flint, animal bone	AD 1270 –1350
10406	Cut		0.82	0.24	Ditch	Pot	Roman
10407	Fill	10406	0.82	0.24	Primary Fill. Mid greyish brown sandy clay		

### Trench 105

General description					Orientation	E-W
Trench contains a ditch. Trench consists of ploughsoil overlying clay geology.					Length (m)	30
					Width (m)	2
					Avg. depth (m)	0.45

Context No.	Type	Fill Of	Width (m)	Depth (m)	Description	Findings	Date
10500	Layer			0.35	Ploughsoil. Mid brown clay silt.		
10501	Layer				Natural. Mid red-brown silt clay.		
10502	Cut		1.48	0.62	Ditch		
10503	Fill	10502	1.2	0.12	Deliberate Backfill. Dark brownish orange silty sandy gravel		
10504	Fill	10502	2.07	0.48	Deliberate Backfill. Mid greyish brown clay silt		
10505	Fill	10502	0.98	0.22	Deliberate Backfill. Dark greyish black clay silt	CBM, Fe	C18–19

### Trench 106

General description					Orientation	SE-NW
Trench contains two ditches. Trench consists of ploughsoil overlying clay geology.					Length (m)	30
					Width (m)	2
					Avg. depth (m)	0.4

Context No.	Type	Fill Of	Width (m)	Depth (m)	Description	Findings	Date
10600	Layer			0.35	Ploughsoil. Mid brown clay silt.		
10601	Layer				Natural. Mid red-brown silt clay.		
10602	Cut		0.6	0.11	Ditch		
10603	Fill	10602	0.6	0.11	Primary Fill. Dark grey-brown silty clay		
10604	Cut		0.73	0.27	Ditch		

10605	Fill	10604	0.73	0.27	Primary Fill. Mid grey-brown silty clay	Pot, flint	MBA-IA
<b>Trench 107</b>							
General description					Orientation		NE-SW
Trench devoid of archaeology. Trench consists of ploughsoil overlying clay geology.					Length (m)		30
					Width (m)		2
					Avg. depth (m)		0.3
Context No.	Type	Fill Of	Width (m)	Depth (m)	Description	Finds	Date
10700	Layer			0.25	Ploughsoil. Mid brown clay silt.		
10701	Layer				Natural. Mid yellowish brown sand clay.		
<b>Trench 108</b>							
General description					Orientation		N-S
Trench contains a single ditch. Trench consists of ploughsoil overlying clay geology.					Length (m)		30
					Width (m)		2
					Avg. depth (m)		0.35
Context No.	Type	Fill Of	Width (m)	Depth (m)	Description	Finds	Date
10800	Layer			0.3	Ploughsoil. Mid brown clay silt.		
10801	Layer				Natural. Mid brown yellow sand clay.		
10802	Cut		0.53	0.12	Ditch		
10803	Fill	10802		0.12	Secondary Fill. Mid grey-brown clay silt.		
<b>Trench 109</b>							
General description					Orientation		NW-SE
Trench devoid of archaeology. Trench consists of ploughsoil over clay sand natural.					Length (m)		30
					Width (m)		2
					Avg. depth (m)		0.41
Context No.	Type	Fill Of	Width (m)	Depth (m)	Description	Finds	Date
10900	Layer			0.39	Ploughsoil. Mid brown clay silt		
10901	Layer				Natural. Mid red-brown clay sand		
<b>Trench 110</b>							
General description					Orientation		N-S
Trench devoid of archaeology. Trench consists of ploughsoil over clay sand natural.					Length (m)		30
					Width (m)		2
					Avg. depth (m)		0.47

Context No.	Type	Fill Of	Width (m)	Depth (m)	Description	Finds	Date
11000	Layer			0.49	Ploughsoil. Mid brown clay silt		
11001	Layer				Natural. Mid red-brown clay sand		
<b>Trench 111</b>							
General description					Orientation		NE-SW
Trench contains a posthole, two ditches and terminus. Trench consists of ploughsoil over clay sand geology.					Length (m)		30
					Width (m)		2
					Avg. depth (m)		0.53
Context No.	Type	Fill Of	Width (m)	Depth (m)	Description	Finds	Date
11100	Layer			0.6	Ploughsoil. Mid brown clay silt		
11101	Layer				Natural. Mid red-brown clay sand		
11102	Cut		0.46	0.16	Posthole. Sub-circular moderately sloping concave sided and flat based posthole.		
11103	Fill	11102	0.46	0.16	Deliberate Backfill. Mid greyish brown moderately compact silty clay with occasional chalk flecks. No finds.		
11104	Cut		0.92	0.38	Ditch. Linear ditch running NW-SE with moderately sloping concave sides with a concave base. Upper fill (11105) contained a clay pipe.		
11105	Fill	11104	0.56	0.08	Deliberate Backfill. Moderately compact mid greyish brown silty clay with occasional chalk flecks. Contained a clay pipe.		
11106	Cut		1.34	0.2	Ditch. Linear ditch with moderately sloping concave sides and a concave base running NW-SE.		
11107	Fill	11104	0.64	0.32	Deliberate Backfill. Very compact light brownish grey clayey sand with		



					occasional chalk flecks. No finds.		
11108	Fill	11104	0.36	0.1	Deliberate Backfill. Moderately compact mid greyish brown silty clay with occasional chalk flecks.		
11109	Fill	11106	0.36	0.1	Deliberate Backfill. Moderately compact mottled mid greyish brown and mid orangish brown silty clay with occasional chalk flecks.		
11110	Cut		0.36	0.04	Ditch. Linear ditch running NE-SW with moderately sloping concave sides and a flat base.		
11111	Fill	11110	0.36	0.04	Deliberate Backfill. Moderately compact mid greyish brown silty clay with no inclusions.		

### Trench 112

General description	Orientation	N-S
Trench consists of topsoil covering an brownish orange natural	Length (m)	30
	Width (m)	2
	Avg. depth (m)	0.4

Context No.	Type	Fill Of	Width (m)	Depth (m)	Description	Finds	Date
11200	Layer			0.35	Ploughsoil. Mid brown clay silt.		
11201	Layer				Natural. Mid yellowish brown silt clay.		
11202	Cut		0.93	0.14	Ditch. NW/SE		
11203	Fill	11202	0.97	0.14	Primary Fill. Dark greyish brown mod compact clayey silt	Pot	Roman
11204	Cut		1.17	0.16	Ditch. NW/SE		
11205	Fill	11204	1.17	0.16	Primary Fill. Dark greyish brown clayey silt		
11206	Cut		1.1	0.26	Ditch. E/W		
11207	Fill		1.1	0.26	Primary Fill. Light brownish grey mod compact clayey silt	Pot, animal bone	Roman

### Trench 113

General description					Orientation		SE-NW
Trench contains two pits. Trench consists of ploughsoil overlying clay geology.					Length (m)		30
					Width (m)		2
					Avg. depth (m)		0.5
Context No.	Type	Fill Of	Width (m)	Depth (m)	Description	Finds	Date
11300	Layer			0.45	Ploughsoil. Mid brown clay silt.		
11301	Layer				Natural. Mid red-brown sand clay.		
11302	Cut		0.97	0.3	Pit		
11303	Fill	11302	0.97	0.33	Primary Fill. Mid grey-brown silty clay		
11304	Fill	11302	0.97	0.14	Secondary Fill. Dark grey-brown silty clay		
11305	Cut		0.61	0.13	Pit		
11306	Fill	11305	0.61	0.13	Secondary Fill. Mid grey-brown silty clay		

#### Trench 114

General description					Orientation		N-S
Trench contains a ditch. Trench consists of ploughsoil overlying clay geology.					Length (m)		30
					Width (m)		2
					Avg. depth (m)		0.45
Context No.	Type	Fill Of	Width (m)	Depth (m)	Description	Finds	Date
11400	Layer			0.35	Ploughsoil. Mid brown clay silt.		
11401	Layer				Natural. Light yellowish brown silt clay.		
11402	Cut		0.7	0.17	Ditch		
11403	Fill	11402	0.7	0.17	Primary Fill. Mid grey-brown silt clay.	Animal bone	
11404	Cut		1.7	0.3	Ditch		
11405	Fill	11404	1.7	0.3	Primary Fill. Moderate mid grey-brown silty clay		

#### Trench 115

General description					Orientation		
					Length (m)		
					Width (m)		
					Avg. depth (m)		
Context No.	Type	Fill Of	Width (m)	Depth (m)	Description	Finds	Date

#### Trench 116

General description						Orientation		
						Length (m)		
						Width (m)		
						Avg. depth (m)		
Context No.	Type	Fill Of	Width (m)	Depth (m)	Description	Finds	Date	
<b>Trench 117</b>								
General description						Orientation		
						Length (m)		
						Width (m)		
						Avg. depth (m)		
Context No.	Type	Fill Of	Width (m)	Depth (m)	Description	Finds	Date	
<b>Trench 118</b>								
General description						Orientation		
						Length (m)		
						Width (m)		
						Avg. depth (m)		
Context No.	Type	Fill Of	Width (m)	Depth (m)	Description	Finds	Date	
<b>Trench 119</b>								
General description						Orientation		E-W
Trench devoid of archaeology consists of plough soil overlying natural clayey sand						Length (m)		29
						Width (m)		2
						Avg. depth (m)		0.4
Context No.	Type	Fill Of	Width (m)	Depth (m)	Description	Finds	Date	
11900	Layer		2	0.4	Ploughsoil. Mid greyish brown, sandy silt, loose, rare rounded stones			
11901	Layer		2		Natural. Mid reddish brown, clayey sand, frequent patches of gravel			
<b>Trench 120</b>								
General description						Orientation		N-S
Contains one linear. Consists of plough soil overlying natural clayey sand.						Length (m)		30
						Width (m)		2
						Avg. depth (m)		0.4
Context No.	Type	Fill Of	Width (m)	Depth (m)	Description	Finds	Date	
12000	Layer		2	0.4	Ploughsoil. Mid greyish brown, sandy silt, loose,			

					occasional rounded stones		
12001	Layer		2		Natural. Mid reddish brown, clayey sand		
12002	Cut		1.24	0.52	Ditch. Cut for a E-W running possible boundary ditch.		
12003	Fill	12002	0.28	0.06	Primary Fill. Light greyish yellow silty sand with frequent angular flint gravel		
12004	Fill	12002	0.32	0.1	Secondary Fill. Light pinkish yellow silty sand		
12005	Fill	12002	0.43	0.06	Secondary Fill. Light yellowish grey silty sand with no inclusions		
12006	Fill	12002	1.05	0.26	Secondary Fill. Mid yellowish grey silty sand with no inclusions		
12007	Fill	12002	1.24	0.14	Secondary Fill. Mid pinkish grey silty sand with very rare angular pebbles		

#### Trench 121

General description	Orientation	E-W
Trench contained one pit. Consists of ploughsoil overlying natural geology of clayey sand.	Length (m)	30
	Width (m)	2
	Avg. depth (m)	0.4

Context No.	Type	Fill Of	Width (m)	Depth (m)	Description	Findings	Date
12100	Layer		2	0.4	Ploughsoil. Mid greyish brown, sandy silt, occasional rounded stones		
12101	Layer		2		Natural. Mid reddish brown, clayey sand, occasional rounded stones		
12102	Cut		0.32	0.05	Pit. Circular pit		
12103	Fill	12102	0.32	0.05	Secondary Fill. Brown orangish, clayey silt, soft.		

#### Trench 122

General description	Orientation	NW-SE
Trench contains one ditch. Consists of plough soil overlaying natural geology of silty clay	Length (m)	30
	Width (m)	2
	Avg. depth (m)	0.35

Context No.	Type	Fill Of	Width (m)	Depth (m)	Description	Finds	Date
12200	Layer			0.35	Ploughsoil. Dark grey-brown, silty clay, firm		
12201	Layer				Natural. Mid red-brown, silty clay, compact		
12202	Cut		1.36	0.36	Ditch		
12203	Fill	12202	1.1	0.22	Deliberate Backfill. Mid yellowish brown, clay, compact	CBM, glass, animal bone	PMed, C18-19
12204	Fill	12202	1.36	0.14	Secondary Fill. Dark brown-grey, silty clay, friable		

### Trench 123

General description	Orientation	E-W
Trench devoid of archaeology consists of plough soil overlying natural clayey sand	Length (m)	39
	Width (m)	2
	Avg. depth (m)	0.4

Context No.	Type	Fill Of	Width (m)	Depth (m)	Description	Finds	Date
12300	Layer		2	0.4	Ploughsoil. Mid greyish brown, sandy silt, loose, occasional rounded stones		
12301	Layer		2		Natural. Mid reddish brown, clayey sand, rare sub angular and rounded stones		

### Trench 124

General description	Orientation	NNW-SSE
Trench devoid of archaeology. Consists of ploughsoil overlying subsoil and natural.	Length (m)	30
	Width (m)	2
	Avg. depth (m)	0.5

Context No.	Type	Fill Of	Width (m)	Depth (m)	Description	Finds	Date
12400	Layer			0.3	Ploughsoil. Mid greyish brown sandy silt with rare pebble inclusions.		
12401	Layer			0.2	Subsoil. Light orange-brown sandy silt with no inclusions.		
12402	Layer				Natural. Mixed light orange yellow silty sand with frequent gravels and light orange-brown silty		

					sand with no inclusions.		
<b>Trench 125</b>							
General description					Orientation		NW-SE
Trench devoid of archaeology, consists of ploughsoil overlying subsoil and sandy natural.					Length (m)		30
					Width (m)		2
					Avg. depth (m)		0.45
Context No.	Type	Fill Of	Width (m)	Depth (m)	Description	Finds	Date
12500	Layer			0.26	Ploughsoil. Dark orange-brown sandy silt with occasional flint inclusions		
12501	Layer			0.19	Subsoil. Light orange-brown sandy silt with no inclusions		
12502	Layer				Natural. Mixed light yellow-orange and light orange-brown silty sand with rare chalk and flint inclusions		
<b>Trench 126</b>							
General description					Orientation		NE-SW
Trench devoid of archaeology. One natural feature. Consists of ploughsoil overlying subsoil and natural.					Length (m)		30
					Width (m)		2
					Avg. depth (m)		0.5
Context No.	Type	Fill Of	Width (m)	Depth (m)	Description	Finds	Date
12600	Layer			0.3	Ploughsoil. Mid orange-brown sandy silt with no inclusions.		
12601	Layer			0.2	Subsoil. Mid orange-brown sandy silt with no inclusions.		
12602	Layer				Natural. Mixed light orange-brown sandy silt and light orange yellow sand.		
12603	Cut		0.64	0.23	Natural Feature. Dark brown orangish, sandy clay, firm. Possible roots.		
<b>Trench 127</b>							
General description					Orientation		N-S

Trench devoid of archaeology. Consists of ploughsoil and subsoil overlying silty clay natural.						Length (m)	30
						Width (m)	2
						Avg. depth (m)	0.5
Context No.	Type	Fill Of	Width (m)	Depth (m)	Description	Finds	Date
12700	Layer			0.29	Ploughsoil. Mid greyish brown sandy silt with occasional rounded pebble inclusions.		
12701	Layer			0.21	Subsoil. Light orange-brown sandy silt with frequent gravel inclusions.		
12702	Layer				Natural. Mottled light creamy yellow and mid yellowish brown silty sand with rare angular flint inclusions		
<b>Trench 128</b>							
General description						Orientation	NE-SW
Trench devoid of archaeology. Consists of ploughsoil and subsoil overlying silty clay natural.						Length (m)	30
						Width (m)	2
						Avg. depth (m)	0.55
Context No.	Type	Fill Of	Width (m)	Depth (m)	Description	Finds	Date
12800	Layer			0.26	Ploughsoil. Dark orange-brown sandy silt with no inclusions		
12801	Layer			0.29	Subsoil. Light yellowish brown sandy silt with no inclusions		
12802	Layer				Natural. Mottled light creamy yellow and mid yellowish brown silty sand with rare angular flint inclusions		
<b>Trench 129</b>							
General description						Orientation	NE-SW
Trench devoid of archaeology. Consists of ploughsoil overlying natural geology of clayey sand.						Length (m)	30
						Width (m)	2
						Avg. depth (m)	0.4
Context No.	Type	Fill Of	Width (m)	Depth (m)	Description	Finds	Date
12900	Layer			0.33	Ploughsoil. Dark greyish brown sandy silt with		

					occasional rounded pebbles.		
12901	Layer				Natural. Mid reddish orange clayey sand with occasional rounded pebbles.		
12902	Layer		0.6	0.2	Remnant Topsoil. Missed topsoil from machining and bioturbation		

### Trench 130

General description	Orientation	N-S
Trench devoid of archaeology. Consists of ploughsoil overlying subsoil and natural.	Length (m)	30
	Width (m)	2
	Avg. depth (m)	0.55

Context No.	Type	Fill Of	Width (m)	Depth (m)	Description	Finds	Date
13000	Layer			0.22	Ploughsoil. Mid orange-grey sandy silt with no inclusions.		
13001	Layer			0.3	Subsoil. Light orange-brown sandy silt with no inclusions		
13002	Layer				Natural. Mid orange-brown sandy silt with patches of light creamy yellow sand.		

### Trench 131

General description	Orientation	NNW-SSE
Trench devoid of archaeology. Consists of ploughsoil overlying natural geology of clayey sand.	Length (m)	30
	Width (m)	2
	Avg. depth (m)	0.32

Context No.	Type	Fill Of	Width (m)	Depth (m)	Description	Finds	Date
13100	Layer			0.32	Ploughsoil. Dark greyish brown sandy silt with occasional rounded pebbles.		
13101	Layer				Natural. Mid reddish orange clayey sand with occasional rounded pebbles.		

### Trench 132

General description	Orientation	NW-SE
---------------------	-------------	-------



Trench devoid of archaeology. Consists of ploughsoil overlaying natural geology of clayey sand.						Length (m)	30
						Width (m)	2
						Avg. depth (m)	0.34
Context No.	Type	Fill Of	Width (m)	Depth (m)	Description	Finds	Date
13200	Layer			0.34	Ploughsoil. Dark greyish brown sandy silt with occasional rounded pebbles.		
13201	Layer				Natural. Mid reddish orange clayey sand with occasional rounded pebbles.		
<b>Trench 133</b>							
General description						Orientation	NNE-SSW
Trench devoid of archaeology. Consists of ploughsoil overlaying natural geology of clayey sand.						Length (m)	30
						Width (m)	2
						Avg. depth (m)	0.32
Context No.	Type	Fill Of	Width (m)	Depth (m)	Description	Finds	Date
13300	Layer			0.32	Ploughsoil. Dark greyish brown sandy silt with occasional rounded pebbles.		
13301	Layer				Natural. Mid brownish orange clayey sand with occasional rounded pebbles.		
<b>Trench 134</b>							
General description						Orientation	NW-SE
Trench revealed two ditches, one of which truncates another. Consists of ploughsoil overlaying natural geology of clayey sand with gravel.						Length (m)	30
						Width (m)	2
						Avg. depth (m)	0.41
Context No.	Type	Fill Of	Width (m)	Depth (m)	Description	Finds	Date
13400	Layer			0.35	Ploughsoil. Dark greyish brown sandy silt with occasional rounded pebbles.		
13401	Layer				Natural. Mid brownish orange clayey sand with occasional patches of gravel.		
13402	Cut		1.62	0.39	Ditch		

13403	Fill	13402	1.62	0.39	Secondary Fill. Mid greyish brown sandy silt with moderate small and fine rounded pebbles and occasional charcoal flecks.	Fe	PMed/Mod
13404	Fill	13402	0.4	0.32	Secondary Fill. Light yellowish grey clayey sand with frequent fine rounded pebbles and occasional shells.	Glass	C19
13405	Cut		0.5	0.23	Ditch		
13406	Fill	13405	0.5	0.23	Secondary Fill. Mid greyish brown sandy silt with occasional small and fine pebbles.		
13407	Fill	13402	1	0.05	Primary Fill. Mid greyish brown sandy silt with occasional fine rounded pebbles.		

### Trench 135

General description

Orientation

NNW-SSE

Trench revealed one ditch. Consists of ploughsoil overlaying natural geology of clayey sand.

Length (m)

30

Width (m)

2

Avg. depth (m)

0.4

Context No.	Type	Fill Of	Width (m)	Depth (m)	Description	Finds	Date
13500	Layer			0.4	Ploughsoil. Dark greyish brown sandy silt with occasional rounded pebbles.		
13501	Layer				Natural. Mid brownish orange clayey sand with occasional rounded pebbles		
13502	Cut		1.4	0.7	Ditch		
13503	Fill	13502	0.7	0.24	Secondary Fill. Mid brownish grey sandy silt with moderate chalk flecks.		
13504	Fill	13502	1.4	0.7	Secondary Fill. Mid greyish brown sandy silt with moderate fine and small rounded pebbles, occasional shells.		

13505	Fill	13502	0.5	0.12	Primary Fill. Mid brownish grey sandy silt with occasional charcoal flecks.		
13506	Fill	13502	0.7	0.24	Secondary Fill. Light yellowish grey clayey sand with frequent fine rounded pebbles and occasional shells.		
<b>Trench 136</b>							
General description					Orientation		NW-SE
Trench contained three cremation deposits and two NW-SE running linears. Consists of ploughsoil and subsoil overlying sandy gravel natural.					Length (m)		30
					Width (m)		2
					Avg. depth (m)		0.44
Context No.	Type	Fill Of	Width (m)	Depth (m)	Description	Finds	Date
13600	Layer			0.33	Ploughsoil. Mid orange-brown sandy silt with occasional rounded pebbles		
13601	Layer			0.12	Subsoil. Light greyish orange sandy silt with occasional gravels		
13602	Layer				Natural. Light yellow-orange sandy gravel		
13603	Cut		0.68	0.16	Ditch. Gully		
13604	Fill	13603	0.68	0.16	Secondary Fill. Light greyish brown, moderately compact, sandy silt with frequent gravel		
13605	Cut		1.3	0.36	Ditch		
13606	Fill	13605	1.3	0.36	Secondary Fill. Light greyish brown, sandy silt with gavel		
13607	Cut		1.5	0.18	Natural Feature		
13608	Cut		1.1	0.42	Tree Throw		
13609	Cut		0.65	0.2	Cremation Cut		
13610	Cut		1.1	0.2	Cremation Cut		
13611	Fill	13610	1.1	0.2	Cremation Deposit. Dark brown, loose, clayey sand with charcoal and occasional fired flint, cremated bones, sub-angular	Flint	

					and rounded stones		
13612	Fill	13609	0.65	0.2	Cremation Deposit	Flint	
13613	Cut		0.34	0.09	Cremation Cut. Not observed to be a separate cut until first spit removed from (13612)		
13614	Fill	13613	0.34	0.09	Cremation Deposit. Dark greyish black sandy silt with frequent burnt bone inclusions.	Flint	
13615	Fill	13609	0.33	0.03	Primary Fill. Light brownish grey sandy silt with no inclusions.		

### Trench 137

General description					Orientation		NW-SE
Trench contains one linear. Consists of ploughsoil overlaying natural geology of sandy gravel.					Length (m)		30
					Width (m)		2
					Avg. depth (m)		0.33
Context No.	Type	Fill Of	Width (m)	Depth (m)	Description	Finds	Date
13700	Layer				Ploughsoil. Dark greyish brown with occasional rounded pebbles.		
13701	Layer				Natural. Mid orangish brown sandy gravel.		
13702	Cut		1.6	0.36	Natural Feature		
13703	Cut		0.78	0.2	Ditch. Gully		
13704	Fill		0.78	0.2	Secondary Fill. Light greyish brown, clayey sand, loose, occasional rounded pebbles		

### Trench 138

General description					Orientation		
					Length (m)		
					Width (m)		
					Avg. depth (m)		
Context No.	Type	Fill Of	Width (m)	Depth (m)	Description	Finds	Date

### Trench 139

General description					Orientation		NE-SW
					Length (m)		30

Trench contains one linear. Consists of ploughsoil overlaying natural geology of clayey sand with gravel.					Width (m)	2	
					Avg. depth (m)	0.41	
Context No.	Type	Fill Of	Width (m)	Depth (m)	Description	Finds	Date
13900	Layer			0.33	Ploughsoil. Dark greyish brown silty sand with occasional rounded pebbles.		
13901	Layer				Natural. Mid reddish orange clayey sand merging with gravel.		
13902	Cut		2	0.66	Ditch		
13903	Fill	13902	1	0.2	Primary Fill. Light greyish white with orange lenses. Silty sand, firm. Finds of pot and coin (sf 1)	Pot, Coin	AD 1–150 (res), AD 260–296
13904	Fill	13902	2	0.46	Secondary Fill. Mid grey-brown with areas of charcoal. Silty clay, Some small stone and flint inclusions. Finds of pot	Pot	AD 43–70

#### Trench 140

General description					Orientation	E-W	
Contains two ditches. Consists of ploughsoil overlaying natural geology of clayey sand and gravel.					Length (m)	30	
					Width (m)	2	
					Avg. depth (m)	0.5	
Context No.	Type	Fill Of	Width (m)	Depth (m)	Description	Finds	Date
14000	Layer			0.4	Ploughsoil. Dark greyish brown silty sand with occasional rounded pebbles.		
14001	Layer				Natural. Mid brownish orange clayey sand merging with gravel.		
14002	Cut		3.2	0.6	Ditch. Enclosure ditch		
14003	Fill	14002	0.5	0.1	Secondary Fill. Very compact greyish orange-brown clayey silt		
14004	Fill	14002	0.1	0.08	Secondary Fill. Compact, mid brownish orange sandy silt.		

14005	Fill	14002	2.8	0.42	Secondary Fill. Moderately compact mid brown sandy silt.	Pot, flint	AD 50–270, PH (res)
14006	Fill	14002	2.1	0.25	Secondary Fill. Moderately compact dark brown sandy silt		
14007	Cut		1.7	0.32	Ditch. N-S ditch		
14008	Fill	14007	1.7	0.32	Secondary Fill. Mid brown sandy silt	Pot	AD 120–250
<b>Trench 141</b>							
General description					Orientation		E-W
Trench revealed seven ditches and one posthole. Consists of ploughsoil and subsoil overlaying natural geology of clayey sand and gravel.					Length (m)		30
					Width (m)		2
					Avg. depth (m)		0.61
Context No.	Type	Fill Of	Width (m)	Depth (m)	Description	Findings	Date
14100	Layer			0.4	Ploughsoil. Dark greyish brown sandy silt with occasional rounded pebbles.		
14101	Layer			0.2	Subsoil. Mid reddish brown sandy silt with rounded pebbles.		
14102	Layer				Natural. Mid brownish orange and yellow clayey sand merging with gravel.		
14103	Cut		0.64	0.34	Ditch. Possible curvilinear, Roundhouse?		
14104	Fill	14103	0.64	0.34	Secondary Fill. Dark brown, sandy silt, soft.		
14105	Cut		0.91	0.3	Ditch. Possible enclosure ditch		
14106	Fill	14105	0.91	0.3	Secondary Fill. Orange-brownish, sandy silt, soft.		
14107	Cut		0.82	0.4	Ditch. Possible enclosure ditch		
14108	Fill	14107	0.82	0.4	Secondary Fill. Dark brown, sandy silt, soft.		
14109	Cut		0.76	0.42	Ditch. Enclosure ditch.		
14110	Fill	14109	0.76	0.42	Secondary Fill. Dark brown orangish, sandy silt, soft.		
14111	Cut		1.31	0.14	Ditch		

14112	Fill	14111	1.31	0.14	Primary Fill. Light brown-orange Sand		
14113	Cut		1.35	0.23	Ditch		
14114	Fill	14113	1.35	0.23	Primary Fill. dark brown Sandy Small stones		
14115	Cut			0.66	Ditch		
14116	Fill	14115		0.18	Primary Fill. Grey orangish/brownish, silt, compact.	Pot	AD 1175 –1400
14117	Fill	14115		0.36	Secondary Fill. Light brown whitish, silt, compact.		
14118	Cut		0.36	0.14	Posthole		
14119	Fill	14118	0.36	0.14	Other Fill. Mid brown, sandy silt, soft.		
14120	Fill	14115		0.16	Secondary Fill. Brown orangish/greyish, sandy silt, moderately compact.		

#### Trench 142

General description		Orientation	E-W/N-S
Trench contains three linears and a tree throw. Consists of ploughsoil overlying gravel natural.		Length (m)	30
		Width (m)	2
		Avg. depth (m)	0.41

Context No.	Type	Fill Of	Width (m)	Depth (m)	Description	Findings	Date
14200	Layer			0.41	Ploughsoil. Dark grey-brown, silty clay, friable		
14201	Layer			0.15	Subsoil. Mid orange-brown, silty clay, friable		
14202	Layer				Natural. Mid brown-orange, sandy clay, friable, frequent gravel inclusions		
14203	Cut		0.54	0.17	Ditch. shallow ditch		
14204	Fill	14203	0.54	0.17	Primary Fill. Mid brown Sand Small stones	Pot, animal bone	UD
14205	Cut		0.96	0.6	Pit. Pit or ditch terminus - unclear due to trench location		
14206	Fill	14205	0.7	0.14	Deliberate Backfill. Very dark grey sandy loam with occasional small burned stones, moderate fired clay and frequent	Pot, CBM, flint	AD 180–250, PH (res)

					charcoal fragments. Full depth of deposit not reached.		
14207	Cut		0.35	0.06	Ditch. cut of shallow ditch		
14208	Fill	14207	0.35	0.06	Primary Fill. light brown Sand One piece of modern pottery	Pot	EPMed
14209	Fill	14205	0.8	0.22	Secondary Fill. Mid yellowish brown sandy silt with moderate small and fine rounded pebbles, rare charcoal flecks.	Pot	Roman
14210	Fill	14205	0.96	0.28	Secondary Fill. Mid greyish brown sandy silt with moderate small and fine rounded pebbles.		
14211	Void						
14212	Void						
14213	Void						

### Trench 143

#### General description

Trench has two ditches. Consists of ploughsoil overlying gravel natural.

#### Orientation

E-W

Length (m)

30

Width (m)

2

Avg. depth (m)

0.43

Context No.	Type	Fill Of	Width (m)	Depth (m)	Description	Findings	Date
14300	Layer			0.27	Ploughsoil. Dark grey-brown, silty clay, friable		
14301	Layer			0.16	Subsoil. Mid orange-brown, silty clay, friable		
14302	Layer				Natural. Mid brown-orange, sandy clay, friable, frequent gravel inclusions		
14303	Cut		0.65	0.3	Ditch		
14304	Fill	14303	0.65	0.3	Secondary Fill. Dark brown orangish, sandy silt, soft.		
14305	Cut		0.7	0.4	Ditch. Enclosure ditch?		
14306	Fill	14305	0.56	0.16	Primary Fill. Grey-brownish, sandy silt, moderately compact.		



14307	Fill	14305	0.7	0.25	Secondary Fill. Dark brown, sandy silt, soft.	Pot, stone	Roman
14308	Cut		0.9	0.1	Natural Feature. Brown orangish, sandy silt, soft. Possible tree throw.		
14309	Cut		0.85	0.3	Ditch		
14310	Fill	14309	0.52	0.22	Secondary Fill. Mid grey orangish, sandy silt, compact.	Animal bone	
14311	Fill	14309	0.85	0.08	Secondary Fill. Mid brown orangish, sandy silt, soft.		
14312	Cut		2	0.5	Ditch. Not fully excavated		
14313	Fill	14312	1.16		Secondary Fill. Grey orangish/brownish, silt, compact.	Pot	AD 170–230
14314	Fill	14312		0.36	Secondary Fill. Light brown whitish, silt, compact.		
14315	Cut		0.68	0.14	Pit		
14316	Fill	14315	0.68	0.14	Secondary Fill. Brown orangish, sandy silt, soft.		
14317	Unexcavated feature		1.45		Pit. Unexcavated pit, truncated by [14319]. Fill is mid brownish grey silty sand with occasional charcoal flecks.		
14318	Unexcavated feature		0.88		Pit. Unexcavated pit, truncated by [14319] and [14317]. Fill is mid brownish grey with charcoal flecks.		
14319	Unexcavated feature		1.88		Pit. Unexcavated pit part of a pit group at eastern end of TR 143. Fill is mid brownish grey silty sand with occasional charcoal flecks.		
14320	Cut		1.6	0.45	Ditch		
14321	Fill	14320	1.28	0.35	Primary Fill. Light greyish white with orange and black lenses. Silty sand, firm.		
14322	Fill		1.6	0.1	Secondary Fill. Dark brown-grey, silty clay		

Trench 144							
General description					Orientation		E-W
Trench contains two ditches and a pit. Consists of ploughsoil overlying gravel natural.					Length (m)		30
					Width (m)		2
					Avg. depth (m)		0.4
Context No.	Type	Fill Of	Width (m)	Depth (m)	Description	Finds	Date
14400	Layer			0.26	Ploughsoil. Dark grey-brown, silty clay, friable		
14401	Layer			0.14	Subsoil. Mid orange-brown, silty clay, friable		
14402	Layer				Natural. Mid brown-orange, sandy clay, friable, frequent gravel inclusions		
14403	Cut		1.33	0.2	Natural Feature. light brown-yellow Small stones Sand		
14404	Cut		0.96	0.03	Natural Feature. Light brown/yellow sand. Occasional small stones		
14405	Cut		0.24	0.02	Natural Feature. light brown/ yellow Sand		
14406	Cut		1.36	0.24	Ditch		
14407	Fill	14406	1.66	0.24	Secondary Fill. Dark brown sand, abundant small stones, yellow-orange sand in the NE corner	Pot	Roman

Trench 145							
General description					Orientation		N-S
Contains dense archaeology of three linears and four pits. Trench consists of ploughsoil overlying gravel natural.					Length (m)		30
					Width (m)		2
					Avg. depth (m)		0.45
Context No.	Type	Fill Of	Width (m)	Depth (m)	Description	Finds	Date
14500	Layer			0.45	Ploughsoil. Dark orange-brown sandy silt with frequent rounded pebbles		
14501	Layer				Natural. Light yellow-orange sandy gravels with frequent rounded pebbles		
14502	Cut		1.04	0.38	Ditch		
14503	Fill	14502	0.9	0.12	Primary Fill. Loose, mid greyish brown silty sand		

14504	Fill	14502	0.18	0.2	Secondary Fill. Soft, mid yellowish brown sandy silt		
14505	Fill	14502	0.9	0.32	Secondary Fill. Soft, mid grey-brown silty sand		
14506	Cut		0.6	0.3	Pit		
14507	Fill	14506	0.6	0.3	Secondary Fill. Soft, light brownish grey silty sand		
14508	Cut		0.6	0.16	Pit		
14509	Fill	14508	0.6	0.3	Secondary Fill. Soft, mid greyish brown sandy silt		
14510	Cut		0.62	0.32	Ditch. truncated by machine		
14511	Fill	14510	0.6	0.32	Secondary Fill. Loose mid greyish brown silty sand		
14512	Fill	14510	0.62	0.15	Secondary Fill. Soft mid brownish grey sandy silt	Pot	AD 170–250
14513	Cut		1.2	0.4	Ditch. Truncated by machine		
14514	Fill	14513	1.2	0.4	Secondary Fill. Soft dark brownish black sandy silt		
14515	Cut		0.62	0.38	Pit		
14516	Fill	14515	0.62	0.35	Secondary Fill. Soft, mid greyish brown sandy silt		
14517	Unexcavated feature		1		Pit. Mid greyish brown, soft, sandy silt fill.		
14518	Unexcavated feature		0.65		Pit. Mid greyish brown, soft, sandy silt fill		

#### Trench 146

General description					Orientation		NW-SE
Trench contains one ditch. Trench consists of ploughsoil overlying gravel natural.					Length (m)		20
					Width (m)		2
					Avg. depth (m)		0.42
Context No.	Type	Fill Of	Width (m)	Depth (m)	Description	Finds	Date
14600	Layer			0.35	Ploughsoil. Dark grey-brown, silty clay, friable		
14601	Layer				Natural. Mid brown orange, sandy clay, friable, frequent gravel inclusions		
14602	Cut		0.9	0.3	Ditch		
14603	Fill	14602	0.9	0.3	Secondary Fill. Soft mid orange-brown silty sand		

14604	Cut		1.63		Natural Feature. Mid greyish brown soft silty sand fill. Moderate sub rounded stones.		
14605	Cut		1.45		Natural Feature. Mid greyish brown, loose, silty sand fill. Frequent sub rounded stone inclusions		
<b>Trench 147</b>							
General description					Orientation		NW-SE
Trench revealed three ditches, two postholes and one potential pit which was left unexcavated. Consists of ploughsoil overlaying natural geology of sandy gravel.					Length (m)		30
					Width (m)		2
					Avg. depth (m)		0.4
Context No.	Type	Fill Of	Width (m)	Depth (m)	Description	Finds	Date
14700	Layer			0.4	Ploughsoil. Dark orange-brown sandy silt with frequent flint pebble inclusions		
14701	Layer				Natural. Light yellow-orange sandy gravel with occasional pebbles		
14702	Cut		0.63	0.21	Ditch		
14703	Fill	14702	0.63	0.21	Secondary Fill. Mid greyish brown silty sand and gravel with occasional charcoal flecks.	Pot	MBA-IA
14704	Cut		0.7	0.12	Ditch. Ditch terminus		
14705	Fill	14704	0.7	0.12	Secondary Fill. Mid orangish brown silty sand and gravel with occasional sub-angular flint fragments.		
14706	Cut		0.31	0.11	Pit		
14707	Fill	14706	0.31	0.11	Secondary Fill. Mid greyish brown silty sand with frequent medium and small sub-angular flint nodules.		
14708	Cut		0.9	0.3	Ditch		
14709	Fill	14708	0.9	0.3	Secondary Fill. Mid greyish brown silty sand and gravel with occasional charcoal flecks and		

					moderate sub-angular flint fragments.		
14710	Cut		0.3	0.28	Posthole		
14711	Fill	14710	0.3	0.28	Deliberate Backfill. Dark brownish grey silty sand and gravel with occasional sub-angular flint inclusions.	Pot	MBA-IA
14712	Unexcavated feature		0.7		Pit		

### Trench 148

#### General description

Dense archaeology of four linears and 25 pits/postholes. Trench consists of ploughsoil overlying gravel natural.

#### Orientation

N-S

#### Length (m)

17

#### Width (m)

14.5

#### Avg. depth (m)

0.36

Context No.	Type	Fill Of	Width (m)	Depth (m)	Description	Findings	Date
14800	Layer			0.36	Ploughsoil. Dark orange-brown sandy silt with frequent rounded pebbles		
14801	Layer				Natural. Light yellow-orange sandy gravel with frequent rounded pebbles		
14802	Cut		0.9	0.2	Ditch		
14803	Fill	14802	0.9	0.2	Primary Fill. Mid grey-brown, silty clay, frequent stone/flint inclusions, finds of pot	Pot	Roman
14804	Cut		0.3	0.04	Pit		
14805	Fill	14804	0.3	0.04	Primary Fill. Dark charcoal rich deposit, some pot	Pot, flint	AD 43-150
14806	Cut		0.94	0.16	Ditch. Uneven along length, rooted in about 50%		
14807	Fill	14806	0.94	0.16	Secondary Fill. Mid greyish brown gravely silt.		
14808	Cut		0.27	0.32	Stake hole. not visible on the surface.		
14809	Fill	14808	0.27	0.32	Secondary Fill. Light grey sandy silt		

14810	Cut		0.5	0.12	Natural Feature. Overlying [14808] and [14806]		
14811	Cut		0.6	0.18	Posthole		
14812	Fill	14811	0.6	0.18	Primary Fill. Mid grey-brown, sandy silt, frequent stone and flint inclusions, no finds		
14813	Cut		1.5	0.48	Ditch		
14814	Fill		0.56	0.14	Primary Fill. Mid grey-brown, sandy silt, rare inclusions, no finds		
14815	Fill	14813	1.5	0.34	Tertiary Fill. Mid grey-brown, sandy silt, frequent stone and flint inclusions, no finds		
14816	Cut		0.98	0.26	Pit. Shallow wide pit.		
14817	Fill	14816	0.98	0.26	Secondary Fill. Dark brown sandy silt.		
14818	Cut		0.48	0.28	Ditch. Linear ditch		
14819	Fill	14818	0.48	0.28	Secondary Fill. Dark brown sandy silt.		
14820	Cut		1.26	0.38	Ditch. Linear ditch		
14821	Fill	14820	1.26	0.38	Secondary Fill. Black sandy silt with moderate stones and roman pot.	Pot	Roman
14822	Cut		1.11	0.25	Pit. Shallow pit		
14823	Fill	14822	1.11	0.25	Secondary Fill. Blackish brown silty sand		
14824	Unexcavated feature		0.25		Posthole. Filled by dark blackish brown silty sand with frequent gravels.		
14825	Unexcavated feature		0.16		Posthole. Filled by dark blackish brown silty sand with frequent gravels.		
14826	Unexcavated feature		0.28		Posthole. Filled by dark blackish brown silty sand with frequent gravels.		
14827	Unexcavated feature		0.6		Pit. Filled by dark blackish brown silty sand with frequent gravels.		

14828	Unexcavated feature		0.18		Posthole. Filled by dark blackish brown silty sand with frequent gravels.		
14829	Unexcavated feature		0.7		Pit		
14830	Unexcavated feature		0.8		Posthole. Filled by dark blackish brown silty sand with frequent gravels.		
14831	Unexcavated feature		0.6		Posthole. Filled by dark blackish brown silty sand with frequent gravels.		
14832	Unexcavated feature		0.42		Posthole. Filled by dark blackish brown silty sand with frequent gravels.		
14833	Unexcavated feature		0.53		Posthole. Filled by dark blackish brown silty sand with frequent gravels.		
14834	Unexcavated feature		0.6		Posthole. Filled by dark blackish brown silty sand with frequent gravels.		
14835	Unexcavated feature		0.23		Posthole. Filled by dark blackish brown silty sand with frequent gravels.		
14836	Unexcavated feature		0.33		Posthole. Filled by dark blackish brown silty sand with frequent gravels.		
14837	Unexcavated feature		0.3		Posthole. Filled by dark blackish brown silty sand with frequent gravels.		
14838	Cut		0.29	0.09	Posthole		
14839	Unexcavated feature		0.18		Posthole. Filled by dark blackish brown silty sand with frequent gravels.		
14840	Unexcavated feature		0.15		Posthole. Filled by dark blackish brown silty sand with frequent gravels.		

14841	Unexcavated feature		0.31		Posthole. Filled by dark blackish brown silty sand with frequent gravels.		
14842	Unexcavated feature		0.18		Posthole. Filled by dark blackish brown silty sand with frequent gravels.		
14843	Cut		0.3	0.09	Posthole		
14844	Unexcavated feature		0.2		Posthole. Filled by dark blackish brown silty sand with frequent gravels.		
14845	Unexcavated feature		0.35		Posthole. Filled by dark blackish brown silty sand with frequent gravels.		
14846	Layer		0.35		Natural. Filled by dark blackish brown silty sand with frequent gravels.		
14847	Unexcavated feature		1.8		Tree Throw. Filled by mid greyish brown sandy silt with no inclusions		
14848	Unexcavated feature		0.5		Posthole. Filled by dark blackish brown silty sand with frequent gravels.		
14849	Unexcavated feature		0.55		Ditch. Possible ditch terminus		
14850	Unexcavated feature		0.85		Ditch. Possible ditch terminus		
14851	Fill	14843	0.3	0.09	Secondary Fill. Dark blackish brown silty sand with frequent gravels.		
14852	Fill	14838	0.3	0.09	Secondary Fill. mid greyish brown silty sand		

#### Trench 149

General description					Orientation		WNW-ESE
Trench has one linear and a posthole. Consists of ploughsoil overlying gravel natural.					Length (m)		30
					Width (m)		2
					Avg. depth (m)		0.38
Context No.	Type	Fill Of	Width (m)	Depth (m)	Description	Finds	Date
14900	Layer			0.3	Ploughsoil. Mid orange grey sandy		



					silt with frequent rounded pebbles		
14901	Layer				Natural. Light yellow-orange silty sand with frequent flint pebbles and gravels		
14902	Cut		0.91	0.25	Ditch		
14903	Fill	14902	0.91	0.25	Primary Fill. Dark brown Loam Abundant gravel		
14904	Cut		0.4	0.26	Natural Feature. Cut for a natural feature. Continues beyond northern LOE of trench. Filled by mid yellow grey sandy clay with rare rounded pebble and gravel inclusions.		
14905	Cut		0.3	0.18	Posthole. Cut for a straight sided posthole		
14906	Fill	14905	0.3	0.18	Primary Fill. Mid orange grey silty sand with rare rounded gravel inclusions		
14907	Cut		0.75		Natural Feature. Change in natural investigated.		
14908	Cut		1.71		Natural Feature. Two interventions dug in natural feature		
14909	Cut		0.92		Natural Feature. Natural feature that was investigated.		

### Trench 150

General description	Orientation	N-S
Trench contains two linears. Consists of ploughsoil overlying gravel natural.	Length (m)	30
	Width (m)	2
	Avg. depth (m)	0.4

Context No.	Type	Fill Of	Width (m)	Depth (m)	Description	Finds	Date
15000	Layer			0.4	Ploughsoil. Dark orange-brown sandy silt with frequent rounded pebbles		
15001	Layer				Natural. Light yellow-orange sandy gravels with frequent rounded pebbles		

15002	Cut		0.84	0.32	Ditch		
15003	Fill	15002	0.84	0.32	Secondary Fill. Mid greyish brown, gravelly sandy silt, loose, occasional bioturbation	Pot	Roman
15004	Cut		0.76	0.3	Ditch		
15005	Fill	15004	0.76	0.3	Secondary Fill. Mid greyish brown, gravelly sandy silt frequent bioturbation and rounded pebbles		
15006	Cut		1.35	0.16	Ditch		
15007	Fill	15006	1.35	0.16	Secondary Fill. Light greyish brown, sandy silt, loose, frequent rounded pebbles	Pot	Roman

### Trench 151

General description		Orientation	W-E
Trench devoid of archaeology consists of plough soil overlying natural clayey sand		Length (m)	30
		Width (m)	2
		Avg. depth (m)	0.3

Context No.	Type	Fill Of	Width (m)	Depth (m)	Description	Finds	Date
15100	Layer		2	0.3	Ploughsoil. Dark brown, silty sand, occasional rounded stones		
15101	Layer		2		Natural. Mid reddish clayey sand, occasional rounded stones		

### Trench 152

General description		Orientation	E-W
Trench devoid of archaeology consists of plough soil overlying natural clayey sand		Length (m)	30
		Width (m)	2
		Avg. depth (m)	0.35

Context No.	Type	Fill Of	Width (m)	Depth (m)	Description	Finds	Date
15200	Layer		2	0.34	Ploughsoil. Dark brown, sandy silt, occasional rounded stones		
15201	Layer		2		Natural. Mid reddish brown, clayey sand, rare rounded stones		
15202	Void						

### Trench 153

General description						Orientation	N-S
Trench devoid of archaeology consists of plough soil overlying natural clayey sand						Length (m)	30
						Width (m)	2
						Avg. depth (m)	0.4
Context No.	Type	Fill Of	Width (m)	Depth (m)	Description	Finds	Date
15300	Layer		2	0.4	Ploughsoil. Dark brown, silty sand		
15301	Layer		2		Natural. Mid reddish brown, clayey sand, occasional rounded stones		

#### Trench 154

General description						Orientation	E-W
Trench devoid of archaeology consists of plough soil overlying natural clayey sand						Length (m)	30
						Width (m)	2
						Avg. depth (m)	0.3
Context No.	Type	Fill Of	Width (m)	Depth (m)	Description	Finds	Date
15400	Layer		2	0.3	Ploughsoil. Dark brown, silty sand, occasional rounded stones		
15401	Layer		2		Natural. Mid reddish brown, clayey sand, occasional rounded stones and fine manganese		

#### Trench 155

General description						Orientation	NE-SW
Trench devoid of archaeology. Consists of ploughsoil overlying sandy clay natural.						Length (m)	30
						Width (m)	2
						Avg. depth (m)	0.35
Context No.	Type	Fill Of	Width (m)	Depth (m)	Description	Finds	Date
15500	Layer			0.35	Ploughsoil. Mid greyish brown sandy silt		
15501	Layer				Natural. Mid orange-brown sandy clay		

#### Trench 156

General description						Orientation	NW-SE
Trench contains one pit. Consists of ploughsoil overlying sandy clay natural.						Length (m)	30
						Width (m)	2
						Avg. depth (m)	0.42

Context No.	Type	Fill Of	Width (m)	Depth (m)	Description	Finds	Date
15600	Layer			0.42	Ploughsoil. Mid greyish brown sandy silt		
15601	Layer				Natural. Light reddish brown silty clay with rare pebble inclusions.		
15602	Cut		0.37	0.2	Pit		
15603	Fill	15602	0.37	0.2	Secondary Fill. Dark brown-grey, sandy clay, firm		

#### Trench 157

General description	Orientation	ENE-WSW
Trench devoid of archaeology. Consists of ploughsoil overlying silty clay natural.	Length (m)	30
	Width (m)	2
	Avg. depth (m)	0.45

Context No.	Type	Fill Of	Width (m)	Depth (m)	Description	Finds	Date
15700	Layer			0.45	Ploughsoil. Mid grey-brown sandy silt with rare gravel inclusions.		
15701	Layer				Natural. Light orange-brown silty clay with occasional gravels.		

#### Trench 158

General description	Orientation	
	Length (m)	
	Width (m)	
	Avg. depth (m)	

Context No.	Type	Fill Of	Width (m)	Depth (m)	Description	Finds	Date
-------------	------	---------	-----------	-----------	-------------	-------	------

#### Trench 159

General description	Orientation	
	Length (m)	
	Width (m)	
	Avg. depth (m)	

Context No.	Type	Fill Of	Width (m)	Depth (m)	Description	Finds	Date
-------------	------	---------	-----------	-----------	-------------	-------	------

#### Trench 160

General description	Orientation	E-W
Trench devoid of archaeology consists of plough soil overlying natural clayey sand	Length (m)	30
	Width (m)	2
	Avg. depth (m)	0.35

Context No.	Type	Fill Of	Width (m)	Depth (m)	Description	Finds	Date
16000	Layer		1	0.35	Ploughsoil. Dark brown, silty sand, occasional rounded stones		
16001	Layer		2		Natural. Mid reddish brown, clayey sand, rare rounded stones and frequent fine manganese		

#### Trench 161

General description	Orientation	N-S
Trench devoid of archaeology consists of plough soil overlying natural clayey sand	Length (m)	30
	Width (m)	2
	Avg. depth (m)	0.35

Context No.	Type	Fill Of	Width (m)	Depth (m)	Description	Finds	Date
16100	Layer		2	0.35	Ploughsoil. Dark brown, silty sand, occasional rounded pebbles		
16101	Layer		2		Natural. Mid reddish brown, clayey sand, rare rounded stones		

#### Trench 162

General description	Orientation	
	Length (m)	
	Width (m)	
	Avg. depth (m)	

Context No.	Type	Fill Of	Width (m)	Depth (m)	Description	Finds	Date
-------------	------	---------	-----------	-----------	-------------	-------	------

#### Trench 163

General description	Orientation	
	Length (m)	
	Width (m)	
	Avg. depth (m)	

Context No.	Type	Fill Of	Width (m)	Depth (m)	Description	Finds	Date
-------------	------	---------	-----------	-----------	-------------	-------	------

#### Trench 164

General description	Orientation	E-W
Trench devoid of archaeology consists of plough soil and colluvium? Overlying silty sand natural	Length (m)	30
	Width (m)	2
	Avg. depth (m)	0.6

Context No.	Type	Fill Of	Width (m)	Depth (m)	Description	Finds	Date
-------------	------	---------	-----------	-----------	-------------	-------	------

16400	Layer		2	0.2	Ploughsoil. Dark brown, silty sand, occasional rounded stones		
16401	Layer		2	0.4	Colluvial Layer. Mid brown, silty sand, occasional rounded stones		
16402	Layer		2		Natural. Light yellowish brown, sandy silt, occasional rounded stones		

#### Trench 165

General description					Orientation		NE-SW
Trench contains one ditch. Consists of ploughsoil overlaying gravelled natural					Length (m)		30
					Width (m)		2.1
					Avg. depth (m)		0.4

Context No.	Type	Fill Of	Width (m)	Depth (m)	Description	Finds	Date
16500	Layer		2.1	0.4	Ploughsoil. Mid grey-brown, silty sand, loose. With rounded stone and potatoes		
16501	Cut		0.59	0.05	Ditch. Shallow n-a ditch		
16502	Fill	16501	0.59	0.05	Secondary Fill. Mid grey silty sand		
16503	Layer				Natural. Light brownish yellow silty sand with occasional gravel patches.		

#### Trench 166

General description					Orientation		E-W
Trench devoid of archaeology consists of plough soil overlying natural silty sand					Length (m)		30
					Width (m)		2
					Avg. depth (m)		0.4

Context No.	Type	Fill Of	Width (m)	Depth (m)	Description	Finds	Date
16600	Layer		2	0.4	Ploughsoil. Dark brown Silty Sand, occasional rounded stones		
16601	Layer		2		Natural. Light yellowish brown with occasional rounded pebbles and hematite		

#### Trench 167

General description					Orientation		NE-SW
Trench devoid of archaeology. Consists of ploughsoil overlying sandy natural.					Length (m)		30
					Width (m)		2
					Avg. depth (m)		0.4
Context No.	Type	Fill Of	Width (m)	Depth (m)	Description	Finds	Date
16700	Layer			0.4	Ploughsoil. Mid grey-brown silty sand, loose with rounded stones		
16701	Layer				Natural. Light brownish yellow silty sand with gravel patches		
<b>Trench 168</b>							
General description					Orientation		N-S
Trench devoid of archaeology consists of plough soil and subsoil overlying natural sandy silt and gravel					Length (m)		30
					Width (m)		2
					Avg. depth (m)		0.4
Context No.	Type	Fill Of	Width (m)	Depth (m)	Description	Finds	Date
16800	Layer		2	0.3	Ploughsoil. Dark brown, silty sand occasional rounded stones		
16801	Layer		2	0.1	Subsoil. Mid greyish brown, silty sand occasional rounded stones		
16802	Layer		2		Natural. Light grey and mid brown silty sand and gravel		
<b>Trench 169</b>							
General description					Orientation		E-W
Trench contains one linear. Consists of ploughsoil overlying sand natural.					Length (m)		30
					Width (m)		2
					Avg. depth (m)		0.4
Context No.	Type	Fill Of	Width (m)	Depth (m)	Description	Finds	Date
16900	Layer			0.4	Ploughsoil. Mid greyish brown sandy silt with occasional rounded pebbles.		
16901	Layer				Natural. Light yellow-orange sand with occasional gravels		
16902	Cut		1.26	0.28	Ditch		
16903	Fill	16902	1.26	0.28	Primary Fill. Mid grey-brown, sandy silt, frequent small		

					rounded stone incl, no finds		
16904	Cut				Natural Feature		
<b>Trench 170</b>							
General description					Orientation	E-W	
Trench contains one ditch. Consists of ploughsoil and subsoil overlying sandy natural.					Length (m)	30	
					Width (m)	2	
					Avg. depth (m)	0.4	
Context No.	Type	Fill Of	Width (m)	Depth (m)	Description	Finds	Date
17000	Layer			0.26	Ploughsoil. Dark greyish brown silty sand with rare pebble inclusions		
17001	Layer			0.14	Subsoil. Mid greyish brown, soft, silty sand		
17002	Layer				Natural. Light yellowish brown, loose, silty sand, occasional gravel patches		
17003	Cut		1.25	0.32	Ditch. N-S ditch		
17004	Fill	17003	1.25	0.32	Secondary Fill. Soft mid greyish brown sandy silt		
<b>Trench 171</b>							
General description					Orientation	E-W	
Trench devoid of archaeology consists of plough soil overlying natural silty sand.					Length (m)	30	
					Width (m)	2	
					Avg. depth (m)	0.35	
Context No.	Type	Fill Of	Width (m)	Depth (m)	Description	Finds	Date
17100	Layer		2	0.35	Ploughsoil. Dark brown, silty sand, occasional rounded pebbles		
17101	Layer		2		Natural. Mid yellowish brown, silty sand frequent gravel patches		
<b>Trench 172</b>							
General description					Orientation	NW-SE	
Trench contains four ditches and two possible postholes. Consists of ploughsoil overlaying natural geology of sand					Length (m)	30	
					Width (m)	2	
					Avg. depth (m)	0.37	
Context No.	Type	Fill Of	Width (m)	Depth (m)	Description	Finds	Date



17200	Layer			0.36	Ploughsoil. Dark grey-brown, silty clay, firm		
17201	Layer				Natural. Mid grey-yellow, silty sand, friable		
17202	Cut		2.1	0.4	Ditch		
17203	Fill	17202	1.4	0.34	Secondary Fill. Mid grey-brown, silty sand, loose		
17204	Cut		0.76	0.46	Ditch		
17205	Fill	17204	0.76	0.46	Deliberate Backfill. Dark brown-grey, silty sand, loose	Pot, animal bone	AD 140–240
17206	Cut		1.38	0.34	Ditch		
17207	Fill	17206	1.38	0.34	Secondary Fill. Mid grey-brown, silty sand, loose		
17208	Cut		2.2	0.4	Ditch		
17209	Fill	17208	2.2	0.4	Secondary Fill. Dark grey-brown, silty sand, loose	CBM, Fe	C16–18, PMed/Mod
17210	Unexcavated feature			0.27	Posthole. Circular in plan. Mid grey-brown, silty sand, loose		
17211	Unexcavated feature			0.24	Posthole. Circular in plan. Mid grey-brown, silty sand, loose		

### Trench 173

General description					Orientation		NW-SE
Trench contains one large probable natural feature which was not bottomed. Consists of ploughsoil overlaying natural clayey sand.					Length (m)		30
					Width (m)		2.1
					Avg. depth (m)		0.4
Context No.	Type	Fill Of	Width (m)	Depth (m)	Description	Finds	Date
17300	Layer		2.1	0.4	Ploughsoil. Mid grey-brown, silty sand, friable with rooting potatoes and rounded stone		
17301	Layer		2.1		Natural. Light whiteish yellow with orange patches, silty sand, with gravel inclusions		
17302	Layer				Colluvial Layer. Large natural feature across most of the base of the trench, present on historic maps, probably natural infilling of a natural		

					depression. Mid brownish grey sandy silt with occasional angular flint inclusions.		
<b>Trench 174</b>							
General description					Orientation		NE-SW
Trench contains one ditch and one unexcavated feature. Consists of ploughsoil overlying sandy natural.					Length (m)		30
					Width (m)		2
					Avg. depth (m)		0.4
Context No.	Type	Fill Of	Width (m)	Depth (m)	Description	Finds	Date
17400	Layer			0.4	Ploughsoil. Dark brown, silty sand, occasional rounded stones		
17401	Layer				Natural. Mid yellowish brown, silty sand frequent gravel patches		
17402	Cut		1.9	0.34	Ditch. East-west running ditch		
17403	Fill	17402	1.9	0.34	Secondary Fill. Loose, mid yellowish brown silty sand		
17404	Unexcavated feature		1.35		Other Cut. Brown silty sand. Possible ditch if not a spread of residual ploughsoil.		
<b>Trench 175</b>							
General description					Orientation		N-S
Trench devoid of archaeology consists of plough soil overlying natural silty sand					Length (m)		30
					Width (m)		2
					Avg. depth (m)		0.35
Context No.	Type	Fill Of	Width (m)	Depth (m)	Description	Finds	Date
17500	Layer		2	0.35	Ploughsoil. Dark brown, silty sand, occasional rounded stones		
17501	Layer		2		Natural. Light yellowish brown, loose, silty sand, occasional gravel patches and frequent hematite		
<b>Trench 176</b>							
General description					Orientation		NW-SE

Trench contains one ditch. Consists of ploughsoil and subsoil overlying natural sand.					Length (m)	30	
					Width (m)	2.1	
					Avg. depth (m)	0.4	
Context No.	Type	Fill Of	Width (m)	Depth (m)	Description	Finds	Date
17600	Layer		2.1	0.3	Ploughsoil		
17601	Layer		2.1	0.23	Subsoil. Mid orangish brown silty sand, friable		
17602	Layer				Natural. Light whiteish yellow, silty sand, with gravel inclusions		
17603	Cut		1.54	0.14	Ditch. E-W shallow ditch.		
17604	Fill	17603	1.54	0.14	Secondary Fill. Dark brown sandy silt with occasional charcoal, small stones and prehistoric pot fragments and one burnt stone.	Pot, flint	MBA-IA

#### Trench 177

General description					Orientation	NE-SW
Trench contains one linear. Consists of ploughsoil overlying sandy natural.					Length (m)	30
					Width (m)	2
					Avg. depth (m)	0.48

Context No.	Type	Fill Of	Width (m)	Depth (m)	Description	Finds	Date
17700	Layer			0.4	Ploughsoil. Mid greyish brown sandy silt.		
17701	Layer				Natural. Light orange yellow with occasional gravel patches.		
17702	Cut		1.58	0.32	Ditch		
17703	Fill	17702	1.58	0.32	Secondary Fill. Mid brown silty sand.		

#### Trench 178

General description					Orientation	NE-SW
Trench devoid of archaeology. Consists of ploughsoil overlying sandy natural.					Length (m)	1.8
					Width (m)	2
					Avg. depth (m)	0.4

Context No.	Type	Fill Of	Width (m)	Depth (m)	Description	Finds	Date
17800	Layer			0.4	Ploughsoil. Dark greyish brown silty sand with		

					occasional rounded pebbles.		
17801	Layer				Natural. Light yellow-orange sand with occasional patches of gravel.		
<b>Trench 179</b>							
General description					Orientation		ENE-WSW
Trench has one linear. Consists of ploughsoil overlying sand natural.					Length (m)		30
					Width (m)		2
					Avg. depth (m)		0.42
Context No.	Type	Fill Of	Width (m)	Depth (m)	Description	Finds	Date
17900	Layer			0.35	Ploughsoil. Dark grey-brown silty sand with occasional flint pebbles.		
17901	Layer				Natural. Light orange sand with occasional patches of gravel		
17902	Cut		0.6	0.26	Ditch		
17903	Fill	17902	0.7	0.26	Primary Fill. Mid grey-brown, silty loam. Some stone inclusions. Slag in fill. Single fill		
17904	Unexcavated feature				Ditch. Ditch terminus, possible curvilinear. Fill silty loam, mid grey-brown.		
<b>Trench 180</b>							
General description					Orientation		NNW-SSE
Trench devoid of archaeology. Consists of ploughsoil overlying sand natural.					Length (m)		30
					Width (m)		2
					Avg. depth (m)		0.45
Context No.	Type	Fill Of	Width (m)	Depth (m)	Description	Finds	Date
18000	Layer			0.35	Ploughsoil. Dark greyish brown silty sand with rare pebble inclusions		
18001	Layer				Natural. Soft light yellow-orange sand with occasional patches of gravel.		
<b>Trench 181</b>							
General description					Orientation		NW-SE

Trench devoid of archaeology. Consists of ploughsoil overlaying a sandy gravelled natural						Length (m)	30
						Width (m)	2.1
						Avg. depth (m)	0.36
Context No.	Type	Fill Of	Width (m)	Depth (m)	Description	Finds	Date
18100	Layer			0.36	Ploughsoil. Mid grey-brown, silty sand, friable with rooting potatoes and rounded stone		
18101	Layer				Natural. Light whiteish yellow, silty sand, with gravel inclusions		
<b>Trench 182</b>							
General description						Orientation	NE-SW
Trench devoid of archaeology. Consists of ploughsoil overlaying natural						Length (m)	30
						Width (m)	
						Avg. depth (m)	0.4
Context No.	Type	Fill Of	Width (m)	Depth (m)	Description	Finds	Date
18200	Layer			0.4	Ploughsoil. Mid grey-brown silty sand, friable with rounded stones	Flint	PH (res)
18201	Layer				Natural. Light whiteish yellow, silty sand, with gravel inclusions		
<b>Trench 183</b>							
General description						Orientation	NW-SE
Trench contains two ditches, one pit and one posthole. Consists of ploughsoil overlaying natural.						Length (m)	30
						Width (m)	2.1
						Avg. depth (m)	0.36
Context No.	Type	Fill Of	Width (m)	Depth (m)	Description	Finds	Date
18300	Layer			0.3	Ploughsoil. Mid grey-brown, silty sand, friable with rooting potatoes and rounded stone		
18301	Layer				Natural. Light whiteish yellow, silty sand, with gravel inclusions		
18302	Cut		0.45	0.3	Pit. Small pit cut by [18304]		
18303	Fill	18302	0.45	0.3	Secondary Fill. Mid brownish grey. Sandy silt. Soft. Rare pebble inclusions		

18304	Cut		1.5	0.5	Ditch		
18305	Cut		0.26	0.15	Posthole		
18306	Fill	18304	0.45	0.2	Secondary Fill. Mid blackish brown. Soft sandy silt. Rare pebble inclusion		
18307	Fill	18304	1.5	0.5	Secondary Fill. Mid greyish brow. Sandy silt. Soft. Moderate sub rounded stone inclusions.		
18308	Fill	18305	0.25	0.15	Secondary Fill. Mid orange-brown sandy silt. Soft. Rare sub rounded stone inclusions		
18309	Cut		1.75	0.18	Ditch. Possible modern feature		
18310	Fill	18309	1.57	0.18	Secondary Fill. Mid greyish brown, loose, sandy silt, occasional small rounded stones, occasional charcoal and frequent bioturbation		

#### Trench 184

General description					Orientation		NE-SW
Trench contains one ditch. Consists of ploughsoil overlaying natural geology of silty sand with gravel					Length (m)		30
					Width (m)		2.1
					Avg. depth (m)		0.33

Context No.	Type	Fill Of	Width (m)	Depth (m)	Description	Findings	Date
18400	Layer		2.1	0.33	Ploughsoil. Mid grey-brown, silty sand, friable with rooting potatoes and rounded stone		
18401	Layer				Natural. Light whiteish yellow, silty sand, with gravel inclusions		
18402	Cut		1.42	0.38	Ditch		
18403	Fill	18402	0.76	0.14	Secondary Fill. Light brown-grey, silty sand, loose	Pot, fired clay	LBA/IA
18404	Fill	18402	1.42	0.24	Secondary Fill. Dark grey-brown, silty sand, loose		

#### Trench 185

General description					Orientation		NW-SE
---------------------	--	--	--	--	-------------	--	-------

Trench devoid of archaeology. Consists of ploughsoil overlaying silty gravelled natural						Length (m)	30
						Width (m)	2.1
						Avg. depth (m)	0.3
Context No.	Type	Fill Of	Width (m)	Depth (m)	Description	Finds	Date
18500	Layer		2.1	0.3	Ploughsoil. Mid grey-brown, silty sand, friable with rooting potatoes and rounded stone		
18501	Layer				Natural. Mid orangish yellow, silty sand, with gravel inclusions		
<b>Trench 186</b>							
General description						Orientation	NW-SE
Trench contains three ditches. Consists of ploughsoil overlaying sandy gravelled natural						Length (m)	30
						Width (m)	2.1
						Avg. depth (m)	0.3
Context No.	Type	Fill Of	Width (m)	Depth (m)	Description	Finds	Date
18600	Layer			0.3	Ploughsoil. Mid grey-brown, silty sand, friable with rooting potatoes and rounded stone		
18601	Layer				Natural. Light whiteish yellow, silty sand, with gravel inclusions		
18602	Cut		1.2	0.22	Ditch		
18603	Fill	18602	1.2	0.22	Primary Fill. Dark grey-brown, silty loam, frequent stone incl		
18604	Cut		1.2	0.2	Ditch		
18605	Fill	18604	1.2	0.2	Primary Fill. Dark grey-brown, silty loam, frequent stone inclusions		
18606	Cut		2	0.58	Ditch		
18607	Fill	18606	2	0.58	Primary Fill. Dark grey-brown, silty loam, frequent stone incl	CBM, animal bone	C14-16
<b>Trench 187</b>							
General description						Orientation	E-W
Trench contains one ditch. Consists of ploughsoil overlaying a sand natural with frequent gravel						Length (m)	30
						Width (m)	2.1
						Avg. depth (m)	0.33
Context No.	Type	Fill Of	Width (m)	Depth (m)	Description	Finds	Date

18700	Layer			0.37	Ploughsoil. Mid grey-brown, silty sand, friable with rooting potatoes and rounded stone		
18701	Layer				Natural. Light whiteish yellow, silty sand, with gravel inclusions		
18702	Cut		0.96	0.22	Ditch		
18703	Fill	18702	0.96	0.22	Secondary Fill. Dark grey-brown, silty sand, loose		

### Trench 188

General description	Orientation	E-W
Consists of ploughsoil overlaying a sandy gravelled natural	Length (m)	30
	Width (m)	2.1
	Avg. depth (m)	0.32

Context No.	Type	Fill Of	Width (m)	Depth (m)	Description	Finds	Date
18800	Layer			0.39	Ploughsoil. Mid grey-brown, silty sand, friable with rooting potatoes and rounded stone		
18801	Layer				Natural. Light whiteish yellow, silty sand, with gravel inclusions		
18802	Cut		0.6	0.05	Pit		
18803	Fill	18802	0.6	0.05	Secondary Fill. loose dark grey sandy silt		
18804	Cut		0.88	0.13	Pit		
18805	Fill	18804	0.88	0.13	Secondary Fill. Loose, dark blackish grey sandy silt		

### Trench 189

General description	Orientation	E-W
Trench contains one ditch and two pits. Consists of ploughsoil and subsoil overlaying natural geology of silty sand with gravel	Length (m)	30
	Width (m)	2.1
	Avg. depth (m)	0.4

Context No.	Type	Fill Of	Width (m)	Depth (m)	Description	Finds	Date
18900	Layer			0.26	Ploughsoil. Dark grey-brown, silty sand, friable		
18901	Layer			0.15	Subsoil. Mid grey-brown, silty sand, friable		
18902	Layer				Natural. Mid grey-brown, silty sand,		



					loose with frequent gravel inclusions		
18903	Cut		1.12	0.26	Ditch		
18904	Fill	18903	1.12	0.26	Secondary Fill. Dark brown-grey, silty sand, loose		
18905	Cut		0.45	0.14	Pit		
18906	Fill	18905	0.45	0.14	Secondary Fill. Dark grey-brown, silty sand, loose		
18907	Cut		0.44	0.15	Pit		
18908	Fill	18907	0.44	0.15	Secondary Fill. Dark grey-brown, silty sand, loose		

### Trench 190

General description					Orientation		NE-SW
Trench devoid of archaeology. Consists of ploughsoil overlaying silty clayey gravelled natural					Length (m)		30
					Width (m)		2.1
					Avg. depth (m)		0.29

Context No.	Type	Fill Of	Width (m)	Depth (m)	Description	Finds	Date
19000	Layer			0.4	Ploughsoil. Mid grey-brown, silty sand, friable with rooting potatoes and rounded stone		
19001	Layer				Natural. Light orange yellow, silty sand, with clay patches and gravel inclusions		

### Trench 191

General description					Orientation		NW-SE
Trench devoid of archaeology. Consists of ploughsoil overlaying a silty gravelled natural					Length (m)		30
					Width (m)		2.2
					Avg. depth (m)		0.3

Context No.	Type	Fill Of	Width (m)	Depth (m)	Description	Finds	Date
19100	Layer		2.1	0.3	Ploughsoil. Mid grey-brown silty sand, friable with rounded stone and potatoes present		
19101	Layer		2.1		Natural. Mid brownish orange, silty sand with gravel throughout, compact		

### Trench 192

General description					Orientation	NE-SW	
Trench contains one ditch. Consists of ploughsoil overlaying a silty gravelled natural					Length (m)	30	
					Width (m)	2.1	
					Avg. depth (m)	0.4	
Context No.	Type	Fill Of	Width (m)	Depth (m)	Description	Findings	Date
19200	Layer			0.4	Ploughsoil. Mid grey-brown, silty sand, friable with rounded pebbles		
19201	Layer		2.1		Natural. Mid brownish orange silty sand with gravel throughout. Firm		
19202	Cut		0.88	0.15	Ditch. Boundary seen on historic map		
19203	Fill	19202	0.88	0.15	Secondary Fill. Dark brownish grey silty sand with occasional rounded pebbles, moderate charcoal fragments varying of sizes and well preserved organic materials.	Pot, Fe, glass	C19-20

## Appendix B Finds Reports

---

### B.1 Prehistoric Pottery

By Alex Davies

#### Introduction

- B.1.1 Some 59 sherds, weighing 158g, were found over 22 contexts in 18 trenches (Table 1). The assemblage is poorly preserved with a mean sherd weight of just 2.7g, suggesting the material has been subject to a significant degree of fragmentation and dispersal after initial discard. The material in many of the contexts could be residual or intrusive.
- B.1.2 There are very few diagnostic sherds. There are only two rims, one very small, and none of the material is decorated. Spot dating is almost entirely based on fabrics. Almost all the material is flint tempered, with the exception of two sherds that contain only quartz sand. The spot date ranges for most of the contexts are broad, reflecting the continuing use of flint as a tempering agent in the region over long periods of time (Evans *et al.* 2016, 70, 105, 160, 379–80), and the small and fragmentary nature of the assemblage dominated by body sherds.

#### Methodology

- B.1.3 Pottery from each context was scanned, with spot dates given based on the latest material present. Fabrics were recorded in order of their approximate frequency in any one context. The two most common inclusion types were noted, using the following fabric codes:
- FI – Flint
  - Qs – Quartz sand
- B.1.4 The grade of the fabric was also recorded with a number suffix, ranging from 1 (fine) to 4 (very coarse).

#### Early Neolithic

- B.1.5 Two contexts (8803 and 8804) have been spot dated to the early Neolithic (probably Plain Bowl) on the basis of their poorly sorted coarse flint fabrics that stands out from the well sorted later prehistoric material from this site and the wider scheme. Three further contexts (9610, 7206 and 6104) produced sherds in a similar fabric, but the spot dates are less certain, as the sherds are very small and abraded; even if they are this date, they could be residual in later contexts.

#### Middle and late Bronze Age

- B.1.6 None of the material was diagnostically middle Bronze Age, although many of the flint-tempered body sherds could be of this date.
- B.1.7 Pottery from context 9805 is probably middle or late Bronze Age in date on the basis of its coarse fabric, although this date is very tentative.
- B.1.8 At least two contexts contained pottery of probable late Bronze Age date (1705 and 18403). Context 1705 contained the only diagnostic rim sherd, and this was incurving, probably from a late Bronze Age hook-rim jar. The pottery in context 18403 is spot

dated to the late Bronze Age/iron Age, but a late Bronze Age perforated clay slab was also found in the context, showing its late Bronze Age date.

- B.1.9 A slight shoulder was found in context 9608 that probably belongs to a late Bronze Age or Iron Age vessel, although this is tentative.

### Iron Age

- B.1.10 No certain Iron Age pottery was found, but contexts 7102 and 10205 have been tentatively spot dated to the Iron Age, as these were the only sherds that did not contain flint. Sand slowly replaced flint in pottery fabrics through the Iron Age in the region, and any contexts containing sandy fabrics are perhaps more likely to have been Iron Age in date rather than Bronze Age (Mucking: Brudenell 2016a, 160; 2016b, 380; South Hornchurch: Harrison 2000, 337–8). However, quantities recovered from this evaluation are very small making such comments tentative. Contexts containing sand and flint are 9303, 10605, 14703 and 14711.
- B.1.11 A complete absence of glauconitic sand makes a middle Iron Age presence unlikely. If any of the material is indeed Iron Age, it is more likely that this is early Iron Age in date.

### Retention

- B.1.12 The pottery has future research value and should all be retained.

Context	Count	Weight (g)	Fabric	Spot date	Comment
1705	2	6	FI2	LBA	Incurving rim. Could be IA?
1707	1	3	FI2	MBA-IA	
4206	1	1	FI2	MBA-IA	Very small and abraded
4406	3	1	FI2	MBA-IA	Very small and abraded
6104	2	8	FI3 (poorly sorted); QsFI2	E Neo?	Poss MBA-IA
6106	2	1	QsFI2	MBA-IA	Very small. Rim
7102	1	4	Qs2	IA?	Very abraded
7206	1	1	FI3 (poorly sorted)	E Neo, or MBA-IA	Very abraded
7704	4	2	FI2	MBA-IA	
8803	3	8	FI3 (poorly sorted)	E Neo	
8804	1	4	FI3 (poorly sorted)	E Neo	
9303	11	23	QsFI2	MBA-IA	Probably IA? Base
9608	3	2	FI2	LBA/IA?	Slight shoulder? Not very diagnostic
9610	2	2	FI3	E Neo or MBA-IA	Very small and abraded
9805	3	12	FI3	MBA-IA	Base. Coarse, more likely M/LBA
10004	4	16	FI2; FI3	MBA-IA	
10205	1	3	Qs2	IA?	Very abraded. Sample 22
10605	1	3	FIQs2	MBA-IA	Poss IA?
14703	1	1	FIQs2	MBA-IA	Very abraded. Poss IA?
14711	1	3	QsFI2	MBA-IA	Very abraded. Poss IA?

<b>Context</b>	<b>Count</b>	<b>Weight (g)</b>	<b>Fabric</b>	<b>Spot date</b>	<b>Comment</b>
17604	10	41	FI3; FI2	MBA-IA	
18403	1	13	FI2	LBA/IA	LBA - context contains perforated slab
<b>Total</b>	<b>59</b>	<b>158</b>			

Table 1: Prehistoric pottery assemblage

## B.2 Late Iron Age and Roman Pottery

By Edward Biddulph

### Introduction

B.2.1 Some 216 sherds of late Iron Age and Roman pottery, weighing 3107g, were recovered from the evaluation (Table 2). Context groups were sorted into fabrics and each fabric group quantified by sherd count and weight in grams. Fabrics were assigned codes devised by the Essex County Council Field Archaeology Unit (cf. Biddulph *et al.* 2015). Forms were identified by rim and quantified by minimum number of vessels (MV) and estimated vessel equivalents (EVE). Forms codes were taken from Going's Chelmsford typology (Going 1987). Forms and fabrics are quantified in Tables 2 and 3.

Fabric	Description	Count	Weight (g)	MV	EVE
ABAET	South Spanish amphora fabric (BAT AM 1)	1	44		
BSW	Black-surfaced wares	33	979	3	0.25
BUF	Miscellaneous buff wares	4	27		
BUFM	Miscellaneous buff ware mortaria	2	398	2	0.23
EGSW	East Gaulish samian ware	1	31	1	0.06
ESH	Early shell-tempered ware	20	55		
GRF	Fine grey wares	11	106		
GROG	Fine grog-tempered ware (SOB GT)	2	30		
GRS	Sandy grey wares	114	1312	10	1.34
MICW	Miscellaneous Iron Age coarse wares	4	12		
NKG	North Kent grey ware (UPC FR)	4	22		
RED	Miscellaneous red wares	7	21		
STOR	Storage jar fabrics	3	65		
UPOT	Unidentified pottery	10	5		
<b>Total</b>		<b>216</b>	<b>3107</b>	<b>16</b>	<b>1.88</b>

Table 2: Quantification of late Iron Age and Roman fabrics (codes in brackets from Tomber and Dore 1998)

Form	Description	BSW	BUFM	EGSW	GRS	Total EVE
B5	Incipient bead-and-flanged dish	0.05			0.22	0.27
C (Drag. 37)	Decorated hemispherical bowl			0.1		0.06
D3.2	Mortarium with tall bead and drooping flange		0.18			0.18
D11	Hammerhead mortarium		0.05			0.05
E	Bowl-jar or wide-mouthed jar				0.23	0.23
G	Jar				0.44	0.44
G5.5	Neckless, lid-seated jar				0.07	0.07
G10	Wide-mouthed and cordoned necked jar				0.17	0.17
G11	Neckless, everted rim jar	0.11				0.11
G23/G24	Oval-bodied necked jar	0.09				0.09

Form	Description	BSW	BUFM	EGSW	GRS	Total EVE
G37.1	Narrow-necked jar with hooked rim				0.21	0.21
<b>Total EVE</b>		<b>0.25</b>	<b>0.23</b>	<b>0.1</b>	<b>1.34</b>	<b>1.88</b>

Table 3: Quantification by EVE of Roman pottery forms

### Assemblage composition

- B.2.2 Five context groups, representing 13% of the assemblage by sherd count, were spot dated to the late Iron Age or early Roman period. These were recovered from Trenches 73, 139, 148 and 186. Contexts 7312 (ditch 7311), 13903 (ditch 13902) and 18603 (ditch 18602) contained shell-tempered pottery (ESH) dating from the early 1st to mid 2nd century AD. Pottery from another fill of ditch 13902 (context 13904) includes grog-tempered ware (GROG), which was accompanied by Roman-period black-burnished ware (BSW). It is possible that all the pottery from the feature was deposited after c AD 43.
- B.2.3 Some 36% of the assemblage by sherd count belonged to context groups spot dated to the middle Roman period (c AD 120–250). The pottery was recovered from six contexts recorded in Trenches 76, 140, 142, 143, 145 and 172. A relatively large group was recovered from context 14206 (pit 14205). Pottery diagnostic of the period from this group includes a lid-seated jar (type G5.5) in sandy grey ware (GRS) and at least three incipient bead-and-flanges dishes (type B5) in fabrics GRS and BSW. Going (1987, 15) dates the dishes to the mid to late 3rd century, but at Mucking (Jefferies and Lucy 2016, 177) the form is suggested to have been current from the late 2nd century. The examples here, however, may well have been made at Orsett itself, where the form is known to have been produced in the early/mid-3rd century (Cheer 1998, 98, 101, fig. 63, no. 21). Overall, a date for deposition within the late 2nd or first half of the 3rd century or later is likely for this group.
- B.2.4 Activity at this time is supported by the presence of a decorated bowl (Drag. 37) in East Gaulish samian ware (EGSW) from context 17205 (ditch 17204), a narrow-necked jar (G37) in fabric GRS from context 14512 (ditch 14510), and two buff ware mortaria (BUFM) from contexts 4604 (ditch 4503) and 14313 (ditch 14312). The mortaria are likely to have arrived from Heybridge, where production of such vessels in the later 2nd and early 3rd century is attested (Biddulph 2015, figs 317 and 318).
- B.2.5 Three groups from Trenches 89, 140 and 143 contained pottery dating to the early to middle Roman period (c AD 43/50–250/70) and represented 15% of the assemblage by sherd count. Pottery includes North Kent grey ware (NKG) from context 14005 (ditch 14002), a possible bag-shaped beaker in fabric GRF from context 14313 (ditch 14312) and a sherd from a South Spanish amphora (ABAET) from context 8903. The last was residual, being found with medieval pottery.
- B.2.6 A large proportion of the assemblage, 35% by sherd count, was from context groups that could not be dated closely within the Roman period (c AD 43–410). This material was collected from Trenches 7, 33, 71, 76, 78, 83, 93, 104, 112, 142, 144, 148 and 150. The pottery typically comprises undiagnostic sherds in coarse wares (BSW, GRF, GRS and RED). Some jar rims were noted, but none could be identified to precise type.

## Discussion

- B.2.7 The assemblage spans the late Iron Age and Roman periods, with the emphasis on the middle Roman period. It is possible that some of the pottery was deposited in the late Iron Age. However, it is notable that no relatively large groups exclusively containing pottery of late Iron Age tradition were recovered and that all grog-tempered ware was associated with Roman-period fabrics, suggesting that all deposition was of Roman or later date. No groups dated with certainty to the late Roman period were recovered.
- B.2.8 With much of the diagnostic pottery being consistent with a later 2nd- or early/mid 3rd-century date, it is a strong possibility that at least a proportion of the pottery was manufactured locally and fired in the kilns uncovered at either Orsett Cock (Cheer 1998) or Hornsby Lane (OA 2020b). That the B5-type dish was among the potters' repertoire has already been noted, and the G5.5 jar is also attested as a local product (Cheer 1998, fig. 63, no. 12). However, the Orsett and Hornsby Lane kilns form part of a much wider zone of pottery production in the south Essex/Thameside region, and it is possible that pottery recovered from the current site was supplied by other workshops. For example, a cordoned, necked jar (type G10) in fabric GRS from context 14206 is similar to types made at Mucking (Jefferies and Lucy 2016, fig. 3.19, type FB01) and Dagenham (Biddulph 2010). Other sources of pottery include the North Kent marshes (NKG), East Gaul (EGSW), Southern Spain (ABAET) and Heybridge (BUFM).
- B.2.9 The condition of the assemblage is mixed. It has a mean sherd weight (weight divided by sherd count) of 14.3g and a mean EVE or 'completeness' value (EVE divided by MV) of 0.12 EVE, which is indicative of the presence of relatively large sherds; a near-complete beaker, for instance, was found in context 14313. However, some context groups consisted of little more than crumbs weighing less than 1g.
- B.2.10 While the assemblage was distributed across the evaluation area, pottery deposition was concentrated in the southern area of the evaluation site. Trenches 139, 140, 142, 143 and 150 contained relatively large amounts of pottery by sherd count, while the 'best-preserved' pottery – that is, pottery with high MSWs and above-average mean EVE values – was recorded in Trenches 142, 143 and 145. This suggests that deposition was concentrated in the southern area and that the pottery in this area had been deposited comparatively rapidly after initial breakage. Trenches in this area targeted features within a system of enclosures, which may have provided a focus of settlement. Elsewhere, the distribution of pottery was sparse and the pottery in poorer condition, suggesting that these areas were more peripheral to areas of use and that the pottery had undergone multiple episodes of redeposition.

## Recommendations for retention

- B.2.11 The pottery reported on here has the potential to inform future research through reanalysis, and thus it is recommended that all the pottery is retained. This follows the advice set out in the *Standard for Pottery Studies in Archaeology* (PCRG *et al.* 2016).



## B.3 Medieval Pottery

By John Cotter

### Introduction and methodology

- B.3.1 A total of 128 sherds of medieval and post-medieval pottery, weighing 1454g, were recovered from 11 contexts. Ordinary domestic wares were recovered. A range of pottery dating from perhaps the early/mid Anglo-Saxon period through to the 19th century was identified. Nearly all of this, however, is medieval in date.
- B.3.2 All the pottery was scanned during the present assessment, and spot dates were provided for each context. Each context group was quantified by sherd count and weight and recorded on a spot-dating spreadsheet. The pottery is mostly in a very fragmentary and abraded condition, but some fresh sherds are also present.
- B.3.3 The context spot date is the date bracket during which the latest pottery types or fabrics are estimated to have been produced or were in general circulation. Comments on the range of fabrics were recorded, usually with mention of vessel form (jugs, bowls etc.) and any other attributes worthy of note (eg. decoration etc.). Fabric codes referred to are those of the Museum of London (MOLA 2014). Where appropriate, these are cross referenced to the fabric codes used by Essex County Council (Cotter 2000, 12–13). The range of pottery is described in some detail in Table 4 and is therefore only summarised below.

Context	Spot date	Count	Weight (g)	Comments
104	c 1550–1900	2	6	2x scraps post-med redware (PMR). 1 glazed; the other very abraded (or poss post-med tile/CBM?)
712	c 1580–1750	2	8	1x bo (body sherd) black-glazed redware (PMBL) probably from a cylindrical mug. 1x bo PMR
3110	13–15C?	1	14	Identification uncertain as very abraded. Probably not Roman. Possibly a thick-walled narrow-necked late medieval drinking jug (or bottle?) in one of the medieval Surrey whitewares – possibly Kingston-type ware (KING, c 1250–1400) or Cheam (CHEA, c 1350–1500)? Wheel-thrown with surfaces mostly worn. Sandy cream-buff fabric. No evidence of glaze surviving. Possibly weathered and plough-damaged, or water-worn.
4208	13–15C?	1	1	Rounded scrap in same fabric as in (3110) but finer (KING/CHEA?). Traces of surfaces. Or unidentifiable?
7604	c 400–750	7	104	Probably 1 jar-like vessel. Anglo-Saxon organic-tempered ware (CHAF). Joining sherds from crudely handmade, slightly odd, slightly shouldered form with plain upright rim (3 rim sherds) and parts of rounded base. Fine silty fabric – abundant voids from burnt-out organic temper. Black fabric. Probably sooted

Context	Spot date	Count	Weight (g)	Comments
8903	c 1000–1225?	10	312	Probably all 1 vessel. Handmade cooking pot profile in shelly ware with everted squared rim and sagging base. Fairly large. Coarse shelly inclusions – mostly dissolved. Also sparse–moderate grainy pellets/lumps of light brown-yellow sandy clay or weathered sandstone (resembling grog)? Possibly Essex EMSHX (c1000–1225)? Or London early med shelly ware (EMSH, c 1050–1150)? Sooted/scorched
10402	c 1270–1350	1	2	Worn bo from jug. Fine orange sandy with some coarser quartz grains. Probably Mill Green ware (MG). Outside covered with white slip under a clear yellow glaze with some green flecks
10405	c 1270–1350	97	936	Minimum 10–12 vessels. Mainly one cooking pot profile with short horiz flanged rim in Mill Green coarseware (MG COAR, fine with just a scatter of quartz grits), one sherd of latter vess has an applied thumbbed vertical strip; sooted ext. Bos from other MG COAR cook pots in coarser fabric, 1 with int clear glaze. 1x sagging base from wide bowl in MG COAR & a squared cook pot rim – both in an oxidised fabric containing sparse dissolved shell inclusions. 4x smallish sherds from Mill Green ware (MG) jugs with ext white slip under clear or green-flecked glaze, including a rod/oval-section jug handle. 1x MG COAR handle terminal from a pipkin or skillet. 1x flat base (diam 70mm) from drinking jug or bottle in Fabric 20 greyware (RCWX, fabric related to MG COAR?). Approx. 10 other sherds F20, & c 20 sherds from cook pots with thumbbed strips in Essex shelly-sandy ware (London SSWX; Essex Fabric 12C) the shell content is only sparse-moderate in this fabric.
14116	c 1175–1400	5	45	Probably all Essex grey sandy ware (Essex Fabric 20/London RCWX)? All bos including 2 joining probably from jug shoulder (wheel-turned?). All sherds weathered with most of original surfaces missing. Mainly grey, or grey-brown with fine silty matrix and moderate-abundant coarse rounded/polished quartz grains and some rare angular flint. Sherds include part of a broken everted neck/rim
14208	c 1480–1600	1	20	Jar/pipkin with everted thickened/beaded rim. Essex-type early post-medieval redware (40EA; similar London PMRE). Glaze specks on neck. Very fresh condition

Context	Spot date	Count	Weight (g)	Comments
19203	c 1820–1900	1	6	Transfer-printed ware (TPW). Bo from ?jug in very hard ironstone-type fabric with blurred light blue floral printed decoration
<b>Total</b>		<b>128</b>	<b>1454</b>	

Table 4: Description of post-Roman pottery by context

## Discussion

- B.3.4 The pottery comprises ordinary domestic wares typical of this part of south Essex and ranges in date from the early/mid Anglo-Saxon period through to the 19th century. Medieval wares of the later 13th to 14th century, however, predominate.
- B.3.5 Context 7604 produced fresh sherds, including rims, from a single jar in early to middle Anglo-Saxon organic-tempered ware (Fabric code CHAF). This ware has a broad date range in south-east England (mainly c AD 400–750) and shows little or no typological change during the period. Some occupation during this date is therefore attested here.
- B.3.6 A cooking pot profile in Essex-type early medieval shelly ware (EMSHX) came from another context (8903). This probably dates to c 1000–1225.
- B.3.7 Most of the pottery here (97 sherds) came from a single context (10405). This can be dated to c 1270–1350 with a fair degree of confidence because of the presence of glazed and white-slipped jug sherds in Mill Green ware (MG). Mill Green ware was produced at Ingatestone in central Essex and had a wide distribution in Essex and the Thames estuary area. Mill Green coarse ware (MG COAR) was another product of this industry. The same context includes one or two well-preserved cooking pots in this fabric, a bowl base and a probable pipkin (saucepan) handle. Sherds of Essex medieval grey sandy ware (Fabric 20/RCWX) are also present, including the base of a small drinking jug or bottle. Sherds from shelly-sandy ware cooking pots (London SSWX; Essex Fabric12C) are present here too. Altogether the pottery from this context – and one or two others – attests to significant occupation here in the late medieval period.
- B.3.8 A small number of post-medieval redware sherds (PMRE, PMR, PMBL) and a single 19th-century sherd (TPW) were also recovered.

## Recommendations regarding the conservation, discard and retention of material

- B.3.9 The pottery here has potential to inform research through reanalysis. It should all therefore be retained and properly catalogued and reported at some future date, along with material from any subsequent formal excavations in this area.

## B.4 Flint

By Lawrence Billington

### Introduction

- B.4.1 A total of 39 struck flints were recovered during the evaluation, alongside a relatively large assemblage of 3798g (over 1000 fragments) of unworked burnt flint, the latter having derived mostly from a series of cremation burials investigated in Trench 136.
- B.4.2 The assemblage was catalogued directly onto an Excel spreadsheet, and the artefacts were classified according to a system of broad artefact/debitage types based on standard definitions for post-glacial lithic assemblages from southern Britain (eg. Bamford 1985, 72–7; Healy 1988, 48–9; Butler 2005). Additional information on selected technological and non-metric attributes of the material (including platform type/preparation, hammer mode and dorsal cortex coverage) was also recorded using standard classifications and terminology based largely on those set out by Inizan (Inizan *et al.* 1999). A summary catalogue of the assemblage is presented in Table 5, with full details of the recording retained in the project archive.

### Raw materials and condition

- B.4.3 The struck flint is varied in terms of colour and texture but is generally fine grained and of good knapping quality. Surviving cortical surface suggests the exploitation of small to medium sized cobbles/nodules, whilst abraded and weathered surfaces indicate a source from secondary deposits of gravel, probably including those of the Boyn Hill Gravel member, which outcrops across the western part of the evaluated area. Similar gravel-derived flint appears to have been the main source of material in the assemblage of predominantly early Neolithic flintwork recovered during excavation of the Orsett causewayed enclosure, immediately to the south of the site (Bonsall 1978), and in the very large multi-period assemblage found during the excavations on the Boyn Hill terrace gravels at Mucking, little more than 2km to the west (Healey 2016). Although most of the unworked burnt flint is heavily shattered, the larger pieces suggest the use of small to medium sized gravel clasts, perhaps rarely in excess of 100mm in maximum dimension, and these too were presumably locally sourced.
- B.4.4 The condition of the worked flint varies, but a high proportion displays at least some slight edge damage/rounding, whilst other pieces – especially those from ploughsoil contexts – had more severe edge damage. Recortication ('patination') is entirely absent.

### Worked flint: quantification and distribution

- B.4.5 The worked flint was very thinly distributed across the site, with the 39 pieces having derived from 28 individual contexts recorded in 20 of the excavated trenches. Most of this material was recovered from the fills of cut features, with seven pieces coming from ploughsoil/subsoil deposits. Given the very low densities of flintwork recovered and the condition of the assemblage, it seems likely that the vast majority of the represents residual material inadvertently caught up in the fills of later features.
- B.4.6 Although the distribution of the flint has not been analysed in great detail, there seems to be at least one notable, but very slight, concentration of flintwork in a restricted area of the site, in the area of Trenches 87, 88 and 96. Ten worked flints were recovered from deposits recorded within these trenches, including both the fills of cut

features and the ploughsoil, and these include a relatively high proportion of fine flakes and blade-based removals, as well as the only two formal retouched tools identified in the assemblage: a serrated blade and an end scraper (see below).

### **Worked flint: technology, typology and dating**

- B.4.7 The small assemblage is overwhelmingly dominated by unretouched removals, alongside one core, two retouched tools and a fragment of hammerstone. The assemblage includes a substantial blade-based component, with blades and blade-like flakes making up over a quarter of unretouched removals. The only core in the assemblage is a very neatly and extensively worked multiple platform blade core (weighing 13g) from pit 4203, Trench 42 (context 4204).
- B.4.8 This blade-based material does not include any kind of very regular, prismatic blades that are most readily associated with Mesolithic technologies, and it seems likely that the majority is of early Neolithic date. A similar date is probable for one of the retouched tools in the assemblage: a serrated blade from the ploughsoil of Trench 88, made on a fine secondary blade blank. This piece bears very fine serrations along one lateral edge (accompanied by some faint use gloss/polish), as well as some serrations with limited dorsal retouches at its distal end. Serrated pieces such as this are a long-lived form, but they are especially common in early Neolithic assemblages, and locally this piece can be compared with early Neolithic examples recovered from the lower fills of the ditch of the Orsett causewayed enclosure (Bonsall 1978, fig. 24, nos 3 and 4). The other retouched tool in the assemblage, a simple convex end scraper from the ploughsoil of Trench 96, could also be of early Neolithic date but could equally represent a late Neolithic or early Bronze Age piece.
- B.4.9 The remainder of the assemblage is dominated by simple flake-based removals, generally hard-hammer struck from unprepared, plain or cortical striking platforms. Little of this material is in any way diagnostic, but much is likely to date to the late Neolithic or early Bronze Age. There is no clear indication of especially crudely/expediently worked material suggestive of a later Bronze Age or Iron Age date.

### **Unworked burnt flint**

- B.4.10 Aside from small quantities of unworked burnt flint from various features investigated across the evaluation area (pits 14205 and 14804; ditches 4605, 6203, 10003, 17603; see Table 5), the vast majority of this material was recovered from a series of cremation burials investigated in Trench 136. This material was recovered from the residues of bulk samples collected from the three cremation burials (13609, 13610 and 13613) and comprises a total of 3687g (some 1040 pieces) of heavily burnt, fractured/shattered fragments of flint.
- B.4.11 Full quantification of the burnt flint recovered from each of the samples from these burials is provided in Table 5. In summary, four samples from cremation burial 13610 produced 2025g of burnt flint, four samples from cremation burial 13609 produced 1638g of burnt flint and three samples from cremation burial 13613 produced a much smaller assemblage of only 24g of burnt flint. The material from all these features was closely comparable, consisting of highly fragmented angular pieces that have experienced severe thermal fracturing. This is reflected in a low mean clast weight of around 3.5g, with the assemblage predominately consisting of small pieces and spalls, alongside a small number of fractured cobbles/pebbles up to c 70mm in maximum dimension.

B.4.12 Although small quantities of burnt flint, presumably inadvertently caught up in the pyre, are a frequent inclusion in prehistoric and Roman cremation deposits, assemblages of this size are unusual. In this context, the reason for its occurrence here is not clear. It seems possible that the pyre site was located on an exposed gravel surface and that heat affected stones were gathered up from the pyre during recovery of the cremated bone, or perhaps even that part of the pyre structure included gravel in its construction, but either way it seems clear that little attempt was made to exclude the burnt flint from the material selected for burial.

### Discussion

B.4.13 Given the scale of the evaluation, the worked flint assemblage can only be described as small, with no large or coherent concentrations of material. Nevertheless, the assemblage provides some indication of prehistoric activity at that site, and it is notable that this includes evidence for early Neolithic activity which may have been broadly contemporary with the construction and use of the nearby Orsett causewayed enclosure. Although it is difficult to make comparisons between assemblages recovered from trial trench and those from more intensively excavated sites, the intensity of prehistoric activity across the evaluated area seems to be significantly lower than that seen on the main areas of the gravel terraces slightly further to the south, as exemplified by the excavations at Mucking, where episodic Neolithic and early Bronze Age occupation was indicated by the very extensive lithic assemblage and occasional pits and pit clusters that contained contemporary pottery (Evans *et al.* 2016).

B.4.14 The large assemblage of unworked burnt flint recovered from the cremation burials in Trench 136 is unusual, and if further work is carried out at the site, this material should be reconsidered in the light of any dating evidence for the burials.

Context	Sample No.	Chip	Irregular waste	Flake	Narrow flake	Blade	Blade-like flake	End scraper	Serrated blade	Multiple platform blade core	Hammerstone fragment	Total worked	Unworked burnt count	Unworked burnt weight (g)
4005	-	-	-	2	-	-	-	-	-	-	-	2	-	-
4204	-	-	-	-	-	-	-	-	-	1	-	1	-	-
4406	-	-	-	1	-	-	-	-	-	-	-	1	-	-
4606	26	-	-	-	-	-	-	-	-	-	-	-	2	12
6104	-	-	-	1	-	-	-	-	-	-	-	1	-	-
6108	-	-	-	-	-	-	1	-	-	-	-	1	-	-
6205	-	-	-	-	-	-	-	-	-	-	-	-	1	21
6900	-	-	-	1	-	-	-	-	-	-	-	1	-	-
6904	-	-	-	-	-	-	1	-	-	-	-	1	-	-
7102	-	-	-	1	-	-	-	-	-	-	-	1	-	-
7206	-	-	-	1	-	-	-	-	-	-	-	1	-	-
7506	-	-	-	-	-	-	1	-	-	-	-	1	-	-
7604	-	-	-	1	-	-	-	-	-	-	-	1	-	-

Context	Sample No.	Chip	Irregular waste	Flake	Narrow flake	Blade	Blade-like flake	End scraper	Serrated blade	Multiple platform blade core	Hammerstone fragment	Total worked	Unworked burnt count	Unworked burnt weight (g)
7605	-	-	1	1	-	-	-	-	-	-	-	2	-	-
8703	-	-	-	1	-	1	-	-	-	-	-	2	-	-
8800	-	-	-	-	-	-	-	-	1	-	-	1	-	-
8803	-	1	-	2	-	-	-	-	-	-	-	3	-	-
8804	-	1	-	-	-	-	1	-	-	-	-	2	-	-
9303	-	1	-	-	-	-	-	-	-	-	-	1	-	-
9600	-	-	-	-	-	-	-	1	-	-	-	1	-	-
9608	-	-	-	-	-	1	-	-	-	-	-	1	-	-
9803	-	-	-	1	-	-	-	-	-	-	-	1	-	-
9805	-	-	-	2	-	-	-	-	-	-	-	2	-	-
10004	-	-	-	-	-	-	-	-	-	-	1	1	1	18
10400	-	-	-	-	-	-	1	-	-	-	-	1	-	-
10405	-	-	-	-	1	-	1	-	-	-	-	2	-	-
10605	-	-	-	1	-	-	-	-	-	-	-	1	-	-
13611	4	-	-	-	-	-	-	-	-	-	-	-	103	780
13611	4	-	-	-	-	-	-	-	-	-	-	-	524	183
13611	5	-	-	-	-	-	-	-	-	-	-	-	160	1016
13611	5	-	-	-	-	-	-	-	-	-	-	-	21	14
13611	6	-	-	-	-	-	-	-	-	-	-	-	16	23
13611	12	-	-	-	-	-	-	-	-	-	-	-	1	9
13612	8	-	-	1	-	-	-	-	-	-	-	1	1	2
13612	8	-	-	-	-	-	-	-	-	-	-	-	18	555
13612	8	-	-	-	-	-	-	-	-	-	-	-	14	13
13612	11	-	-	-	-	-	-	-	-	-	-	-	54	17
13612	12	-	-	-	-	-	-	-	-	-	-	-	92	996
13612	12	-	-	-	-	-	-	-	-	-	-	-	24	11
13612	15	-	-	-	-	-	-	-	-	-	-	-	6	44
13614	10	-	-	-	-	-	-	-	-	-	-	-	1	9
13614	13	-	-	-	-	-	-	-	-	-	-	-	3	9
13614	16	-	-	-	-	-	-	-	-	-	-	-	2	6
14005	-	-	1	3	-	-	-	-	-	-	-	4	-	-
14206	14	-	-	-	-	-	-	-	-	-	-	-	14	27
14206	14	-	-	-	-	-	-	-	-	-	-	-	4	5
14805	2	-	-	-	-	-	-	-	-	-	-	-	4	22
17604	-	-	-	-	-	-	-	-	-	-	-	-	1	6
18200	-	-	-	1	-	-	-	-	-	-	-	1	-	-
Total		3	2	21	1	2	6	1	1	1	1	39	1067	3798

Table 5: Flint assemblage

## B.5 Fired Clay

By Alex Davies

- B.5.1 A single piece of fired clay was found in context 18403. This is from a late Bronze Age perforated slab/plate. The piece weighs 40g and measures 48 x 42 x 15mm. It is from the corner of the object, surviving up to the edge of the nearest perforation. The rim on one of the edges is a dished U-shape. The fabric includes fine-moderate flint, very similar to the pottery sherd found in the same context. These are common late Bronze Age finds in the lower Thames Valley/estuary (Harrison 2000).

### Retention

- B.5.2 The piece has future research value and should be retained.



## B.6 Ceramic Building Material

By Kirsty Smith and Cynthia Poole

### Introduction and methodology

- B.6.1 A modest quantity of ceramic building material (CBM) amounting to 63 fragments, weighing 4.7kg, was recovered from Trenches 1, 5, 7, 25, 47, 76, 89, 105, 122, 142, 172 and 186. The majority of the assemblage is post-medieval in date, although six fragments of Roman tile and one fragment of medieval tile was also recovered. The fragments of Roman tile are heavily abraded and poorly preserved (except for two fragments of tegula), whereas the post-medieval material has moderate abrasion, and several larger fragments of brick are well preserved. The assemblage has a mean fragment weight of 155g.
- B.6.2 The assemblage has been fully recorded on an Excel spreadsheet in accordance with guidelines set out by the Archaeological Ceramic Building Materials Group (ACBMG 2007) and is summarised in Table 6. The record includes quantification and details of fabric type, form and evidence of use/reuse (burning etc.). Fabrics were characterised on the basis of macroscopic features supplemented by the use of x40 hand lens for finer constituents.

### Roman tile

- B.6.3 The Roman tile comprises two fragments of tegula roofing tile and four fragments of flat tile, weighing 411g in total. Dating cannot be more precise than to the Roman period for this small assemblage. These fragments were made in a variety of red/pink-orange fine sandy fabric with mica inclusions. The two joining fragments of tegula are worn but relatively well preserved and have a standard upper cutaway 41mm long. These fragments were recovered from ditch 111 in Trench 1. The flange is 13.5mm wide and had possibly been removed deliberately for reuse as a flat tile. The other four fragments of Roman flat tile are 17–23mm thick and were recovered from pit 7606, ditch 8902 and pit 14205. These fragments have burning on one or more surfaces, perhaps indicating reuse of the material in an oven or hearth.
- B.6.4 A scrap of possible CBM or fired clay (4g) from context 7606 was made in a mauve, coarse sandy fabric. The fragment is small and amorphous and may be a lump of burnt natural sediment rather than deliberately formed.

### Medieval CBM

- B.6.5 One late medieval to early post-medieval peg tile of 14th- to 16th-century date was recovered from Trench 186 (context 18607). This weighs 161g and measures 15mm thick. It was made in an orange-pink sandy fabric, containing iron oxide grit inclusions. The tile was roughly finished and has an uneven peg hole at one end that measures 12.8mm in diameter.

### Post-medieval CBM

#### *Brick*

- B.6.6 The post-medieval brick comprises 43 fragments (3310g) that were found in ditches revealed in Trenches 5, 7, 25 and 122. Brick was also found in one unexcavated pit in Trench 47. The majority of these bricks were made from an orange-red moderately sandy fabric, apart from the brick from 4703, which is a dark brownish purple/red colour. The inclusions within these brick fragments vary. The bricks from Trenches 7

and 47 have black cinder, coarse flint and quartzite >5mm inclusions. The bricks from Trenches 5, 25 and 122 were made in a distinctive fabric with cream laminations and cream clay pellets and iron oxide grit inclusions.

- B.6.7 Three bricks from contexts 504, 713 and 2508 are more complete than the others, the first two being 55mm thick and the brick from 2508 being 66mm thick. The brick from context 504 dates to the 17th-18th century and the brick from 713 to the 16th-17th century. The brick from 2508 was more regularly finished with sharp arrises, probably having been produced in a metal-lined stock mould, and dates to the 18th-19th century. The rest of the bricks comprise amorphous fragments and could not be dated more precisely than to the post-medieval.

#### *Floor tile*

- B.6.8 Two fragments of floor tile/paviours (647g) were recovered from Trenches 5 and 105. The unglazed brick paviour or floor tile from 504 was made in an orange sandy fabric with cream striations and contains iron oxide grit and mica inclusions. It is 39mm thick and has creasing along one edge and burning on the tip of one edge, suggesting possible use as a hearth brick. This paviour dates to the 17th–18th century. The brick paviour from context 10505 was made from an orange-pink sandy fabric containing mica and black cinder inclusions. This paviour has a regular finish, creased edge surface and angular arrises, possibly indicating a metal mould was used. This paviour dates to the 18th–19th century.

#### *Roof tile*

- B.6.9 Five fragments of post-medieval flat rectangular roof tile (167g), probably of peg tile form, were recovered from Trenches 105 and 172. These were made from an orange-pink sandy fabric with mica inclusions. The roof tile from 17209 is 13mm thick and dates to the 16th–18th century. The fragment of tile from 10505 could not be dated more precisely than to the post-medieval period.

Context	Spot date	Count	Weight (g)	Form	Comments
112	Roman	2	152	Tegula	Tegula joining pieces (fresh break). Standard upper cut away 41mm long. Flange (13.5mm wide) removed possibly for reuse. Thickness 25mm
504	c 17–18	1	333	Brick paviour or floor tile	Unglazed floor tile with creasing along the edge and burning on tip of one edge. Thickness 39mm
504	c 17–18	1	413	Brick	Brick – similar date to floor tile in 504. Three surfaces. Thickness 55mm
504	Post-medieval	5	6	Unknown	Five small frags of unknown type with burning on the surface (burnt grey) probably part of the floor tile
710	Post-medieval	13	221	Brick	Amorphous frags of brick with chalk inclusions
712	Post-medieval	8	442	Brick	Amorphous frags of brick with chalk grit and flint pebbles

Context	Spot date	Count	Weight (g)	Form	Comments
713	c 16–17	2	629	Brick	Two bricks (part of). Two surfaces on each. Thickness 55mm
2508	c 18–19	2	1128	Brick	Two bricks (part of). Regular angles – metal lined stock mould? Three surfaces. Thickness 66mm
4703	Post-medieval	1	251	Brick	Brick with pebble inclusions, one surface
7606	Roman	2	64	Flat tile	Burning on lower surface and underfired. Thickness 22mm
7606	Undated	1	4	Indeterminate	Amorphous frag – uncertain CBM/FC/stone?
8903	Roman	1	91	Flat tile	burning on base and the broken edge suggest reuse. Thickness 17mm
10505	Post-medieval	1	8	Roof: flat	
10505	c 18–19	1	314	Brick paviour	Creased surface. Angular edges – metal mould. Two surfaces. Thickness 49mm
12203	Post-medieval	16	226	Brick	Amorphous frags of brick with iron oxide inclusions
14206	Roman	1	104	Flat tile	underfired, base missing. Burning on upper surface and heat discoloured. Thickness 23mm
17209	c 16–18	4	159	Roof: flat	Flat tile, red with grey/red core. Thickness 13mm
18607	c 14–16	1	161	Roof: peg	Peg hole uneven (12.8mm diameter). Rough finish. Broken edge worn to a bevel on one corner – reused. Thickness 15mm

Table 6: Ceramic building material assemblage

## Conclusions

- B.6.10 The assemblage is moderate in size and the material is fragmentary but includes a few larger fragments of post-medieval brick and brick paviour.
- B.6.11 The amount of Roman tile is very small, especially when compared to the amount of Roman pottery recovered. The tile occurred as a sparse scatter across the site in Trenches 1, 76, 89 and 142, coinciding with the occurrence of Roman pottery, which spanned the late Iron Age and Roman periods but with the main emphasis on the middle Roman period. The flat tile shows signs of burning, which suggests reuse of the material in oven or hearth structures, as does the deflanging of the tegula. The Roman CBM is moderately to heavily abraded, suggesting the material may have undergone several episodes of disturbance and redeposition before reaching its final place of deposition. The small quantity of Roman tile recovered compared to pottery is perhaps surprising, as by the middle Roman period one might expect some surplus tile to have been filtering down to lower status settlements. It suggests that the site may have had no direct links to a higher status settlement, such as a villa, from which disused tile could have been obtained.

- B.6.12 The majority of the assemblage is post-medieval in date. The earliest item is a peg tile of 14th- to 16th-century date found in Trench 186, located in the south-eastern part of the site and south of Stanford Road.
- B.6.13 The post-medieval CBM was found at a number of foci across the site. Half of the material recovered was found in Trenches 5 and 7, plus a smaller group from Trench 25, all of which were located in the north-eastern block of the site, bounded by Stanford Road (A1013), Brentwood Road and Rectory Road. Trenches 47 and 105 were located in the western part of the site and north of Stanford Road and south of the A13. Trench 122 was located to the south of Stanford Road and west of Hornsby Lane. Trench 172 was located in the eastern part of the site and south of Stanford Road. These trenches rarely produced more than a single item each (the fragments from Trench 122 probably represent a single shattered brick fragment). Later 19th-century Ordnance Survey maps indicate a number of farms and cottages stood along Stanford Road and Hornsby Lane. It is possible that the post-medieval brick and tile originated from some of these farms and cottages and that concentrated in Trenches 5 and 7 possibly relates to a building of 17th-century date in the vicinity. Elsewhere the post-medieval CBM may represent casual loss, most probably dispersed by agricultural activity.

### **Recommendations**

- B.6.14 The assemblage provides some supplementary dating evidence for the contexts. This assemblage has limited intrinsic research value except perhaps some tentative association with post-medieval buildings in the locality.
- B.6.15 In general, the archive record together with any items recommended for retention should be sufficient in any wider research encompassing the site or the material. A small selection of diagnostic pieces providing a representative sample of fabrics and forms should be retained as indicated in the archive record. Other material may be discarded upon completion of the project prior to archiving.

## B.7 Metals

By Anni Byard

### Introduction and methodology

- B.7.1 A total of 65 metal objects (572.4g) were recovered during the evaluation (Table 7). This comprises 64 iron objects (570.5g) and one copper alloy object (1.9g) collected from six contexts across six trenches. Most of the artefacts are of later post-medieval or modern date, while three objects may date to the Roman period.
- B.7.2 All the metalwork was scanned during the present assessment and, where possible, century or broad period dates were assigned. Objects were quantified by type count and weight by context and were recorded on an Excel spreadsheet.

Context	Material	Count	Weight (g)	Object	Date	Description
6804	Fe	10	300	Vessel?	PM/ Mod	Six refitting fragments of a bucket hoop, probably from the top of the bucket. Four small, loose fragments. Probably 19th-early 20th century
10505	Leather/ Fe	1	44.5	Shoe	PM/ Mod	Leather boot heel with hobnails.
10505	Fe	4	53.5	Chain?	PM/ Mod	Four loops / links, corroded together, plus one loose, incomplete possible oval link.
10505	Fe	1	27.7		PM/ Mod	Heavily corroded rod(s). Uncertain function
10505	Fe	2	12.6		PM/ Mod	Heavily corroded iron fragments including a possible nail
13403	Fe	38		Vessel?	PM/ Mod	38 fragments of thin iron sheet. Two pieces have been rolled to create a hollow 'rim'.
13903	Cu alloy	1	1.9	Coin	Roman	Very worn and corroded probable radiate. AD 260–296. SF 1
13903	Fe	1	6.9		Roman?	Corroded sheet fragment
13903	Fe	1	21.9		Roman?	Curved bar
17209	Fe	1	32.5	Ring	PM/ Mod	Flat, circular iron ring, uneven width and uneven central circular hole. SF 2. Washer-like object, uncertain function. Probable PM /Mod
17209	Fe	1	11	Nail		Encrusted short rectangular rod, probably a nail shank
19203	Fe	1	21.1	Rod		Sub-rectangular-sectioned rod or bar, 131mm length. Uncertain function

Context	Material	Count	Weight (g)	Object	Date	Description
19203	Fe	1	22	Rod		Tapering rod of rectangular section, bent. 165mm length. Uncertain function
19203	Fe	1	6.6	Nail		U-shaped staple, 40mm length.
19203	Fe	1	10.2	Nail	PM?	Rectangular shank with square head

Table 7: Description of metalwork by context

## Discussion

- B.7.3 The metalwork assemblage comprises mostly fragmentary iron objects of later post-medieval or modern date, generally dating to the 19th or early 20th centuries. The single copper alloy object is a Roman coin of probable later 3rd-century date.
- B.7.4 Notable finds include a bucket hoop of six refitting pieces from Trench 68 (context 6804). The hoop is formed of an iron band approximately 34mm deep with a folded over section on one edge, which is probably the rim of the vessel. This fold creates an internal lip that may have secured wooden staves. No rivet holes are visible on initial inspection. The reassembled hoop has a diameter of 200mm.
- B.7.5 Trench 105 produced the largest amount of metalwork, comprising eight objects. This includes the remains of a leather boot heel (context 10505). Of probable 19th-century date, the heel comprises three layered pieces of leather, with no obvious stitching holes. The heel retains ten hobnails, of which all heads are broken and missing. The hobnail arrangement appears random. The lack of stitch holes through the leather could suggest adhesive, an early 20th-century development; however, the sole could also have been nailed through to the upper, a technique developed from the 1860s.
- B.7.6 A collection of four loops or possible chain rings/links were recovered from the same context. These are all corroded into one mass. It is uncertain whether any loops inter-link. The form of link could date anywhere from the Roman period to the modern era, although the latter is more likely. They may be harness related.
- B.7.7 The remaining three iron objects from Trench 105 (context 10505) are corroded rod fragments, including a possible nail stem.
- B.7.8 Trench 139 yielded two iron objects: a curved bar and a corroded sheet fragment of uncertain date. The copper alloy coin recovered from this trench is extremely worn and corroded but is probably a radiate issue of the later 3rd century AD (c AD 260–96). All these objects were recovered from context 13903.
- B.7.9 The remaining objects comprise a rod section flat iron ring (possibly a large washer-like object) from Trench 172 and two rod sections, a U-staple and a nail with square head from Trench 192. The staple and nail are likely to be of post-medieval or modern date.

## Recommendations regarding the conservation, discard, and retention of material

- B.7.10 The assemblage is small and generally of modern date. The objects of probable Roman date from Trench 139 should be retained, as should the bucket hoop from Trench 68. The leather shoe fragment and chain links from Trench 10505 should be

retained, but the remaining objects from this trench are of little value and have been fully recorded so could be discarded, as could the rest of the assemblage.

## B.8 Glass

By Anni Byard

### Introduction and methodology

- B.8.1 A total of 17 shards of glass (145.4g) were recovered from four contexts from four trenches (Table 8). The assemblage is generally of 19th- or early 20th-century date.
- B.8.2 The glass was scanned during the present assessment and, where possible, century or broad period dates were assigned. Shards were quantified by count and weight by context and were recorded on an Excel spreadsheet.

Context	Count	Weight (g)	Object	Date	Description
6205	5	16.4	Bottle	19/20th C	Shards from the same light green wine bottle. Probably later 19th / 20th century
12203	1	34.1	Bottle	18th/19th C	Basal / heel rim shard from a dark green probable wine bottle.
13404	2	30	Bottle	19thC	Bulbous neck shard from a 19th century cylinder bottle. Dark olive green.
19203	6	52	Bottle	19/20th C	Body shards from a dark olive-green wine bottle. Probably moulded. One fragment appears knapped.
19203	2	10.5	Bottle	19/20th C	Two body shards of clear glass, small milk bottle or similar. The larger fragment appears to have been knapped.
19203	1	2.4	Query	19/20th C	Thick, light aqua blue clear curved shard. Thickness of glass (5mm) suggests later 20th century.

Table 8: Description of glass assemblage by context

- B.8.3 Most of the glass comprises wine bottle fragments of olive-green hue. A basal or heel rim shard in a dark green glass with surface weathering is from a wine bottle of later 18th-, but more likely, 19th-century date. This appears to be the earliest fragment recovered during the evaluation.
- B.8.4 Of note are two shards from Trench 192 (context 19203). In a collection of nine shards from this context, two pieces display probable knapping. This suggests that the fragments were reutilised after their original disposal. Knapped glass of late post-medieval/modern date is recorded from other 18th- and 19th-century sites in the UK (in particular east London), as well as in indigenous communities at historic sites in Australia and America.

### Recommendations regarding the conservation, discard, and retention of material

- B.8.5 Further research and investigation are needed into the glass objects to ascertain if they have been intentionally knapped or if the flaking is a product of some other factor. Should they prove to have been knapped, they should be illustrated and published in a suitable publication and retained.



B.8.6 The glass not associated with the knapped fragments has been recorded. It is of modern date and offers little potential to inform subsequent works, so it could be discarded.

## B.9 Worked Stone

By Ruth Shaffrey

- B.9.1 A total of eight pieces of stone were retained and submitted for analysis. These were examined with a x10 magnification hand lens for signs of use. Worked or utilised items were recorded and details entered into a Microsoft Excel spreadsheet.
- B.9.2 Two fragments of Mayen lava, weighing 53g, were recovered from contexts 14307. These are too degraded for anything to be said about their form, but as Mayen lava is only known to have been imported for use as rotary querns, it is assumed that this was their function. It is likely that they are of Roman date because these were first introduced to Britain at the time of the Roman conquest in AD 43 and were widely used thereafter, but Saxon or medieval dates are also possible.
- B.9.3 A single whetstone was recovered from context 8903. This is made of a grey schist known as Norwegian Rag. Norwegian Rag was the stone type most commonly used for whetstones in Britain from the 9th century AD onwards (Hansen 2009). It is not found in Roman contexts.

### Recommendations

- B.9.4 All the unworked and/or burnt stone can be discarded, but the lava fragments and whetstone should be retained in case of future geochemical or petrographic analysis.

### C.1 Environmental Samples

By Richard Palmer

#### Introduction

- C.1.1 Twenty-six bulk samples were collected as part of the evaluation, primarily for the retrieval and assessment of charred plant remains (CPR) and the recovery of bones and artefacts.

#### Method

- C.1.2 The samples were processed in their entirety at Oxford Archaeology using a modified Siraf-type water flotation machine. The flots were collected in a 250µm mesh and residues in a 500µm mesh and dried. The residue fractions were sorted by eye and with the aid of a magnet, while the flot material was sorted using a low power (x10) binocular microscope to extract cereal grains and chaff, smaller seeds and other quantifiable remains.

#### Results

- C.1.3 Sample summary and flot abundance data is presented in Table 9.
- C.1.4 **Trench 33.** Sample 1 from fill 3304 of ditch 3303 produced a modest flot. Most of the material has surface concretions, but identification was still possible in most cases. The grain is often fragmented and consists of wheat (*Triticum* sp.) and possible oat (cf. *Avena* sp.). Charred goosefoot seeds are also present (*Chenopodium* sp.), and the recovered glume bases have spelt-like characteristics (*Triticum spelta*). Roman pottery was recovered from the residue.
- C.1.5 **Trench 46.** Sample 26 from fill 4606 of ditch 4605 produced a large flot. The charcoal includes some ring porous fragments and roundwood in the form of twig fragments. Most of the grain is wheat, with a little oat also present. Many legumes of various sizes were also recovered, the largest being about 4mm, and are probably a mix of vetches. A bedstraw seed (*Galium* sp.) was also identified. A little burnt flint was extracted from the residue.
- C.1.6 **Trench 76.** Sample 25 from fill 7604 of pit 7614 produced a large flot. Some of the charcoal fragments are >10mm in size, and multiple species are present in the assemblage. Grain includes barley (*Hordeum vulgare*) and possible wheat. Anglo-Saxon pottery, fired clay and burnt stone were recovered from the residue.
- C.1.7 **Trench 102.** Sample 22 from fill 10205 of pit 10203 produced a flot consisting of a small quantity of charcoal. Possible Iron Age pottery was recovered from the residue.
- C.1.8 **Trench 113.** Sample 3 from fill 11303 of pit 11302 produced a flot consisting of a small quantity of charcoal. No artefacts were recovered from the residue.
- C.1.9 **Trench 136.** The bulk of the samples from this site were collected as spits through three cremation burial cuts encountered in this trench.
- C.1.10 Eight samples were collected from cremation 13609 (samples 8, 11, 12, 15, 18, 20, 21, 24). Eight of them were from fill 13612, which includes spits through the cremation

burial and the surrounding material. Sample 21 was from fill 13615, comprising material underlying the cremation deposit. Charcoal was recovered from all samples, some of which is ring porous, and occasional speedwell seeds (*Veronica* sp.) are also present. Calcined bone was recovered from all residues except 20 and 21, and burnt flint was present in multiple residues.

- C.1.11 Four samples were collected from cremation burial 13610 (samples 4–7), all from fill 13611. Sample 4 was a 50L bulk sample, so the standard 40L was processed as laid out in the method section, with the excess 10L being wet sieved to 500µm to enable recovery of bones and artefacts. Samples 4, 5 and 6 produced large quantities of charcoal, with a wheat fragment also recovered from sample 5. Calcined bone and burnt flint were recovered from the residues of samples 4, 5 and 6, with no artefacts present in the residue from sample 7.
- C.1.12 Six samples were collected from cremation burial 13613 (samples 10, 13, 16, 17, 19, 23), all from fill 13614. Charcoal was recovered from all samples, some of which is ring porous, and speedwell seeds are present in several. Calcined bone was recovered from the residues of all samples except sample 19, and burnt flint was recovered from several residues.
- C.1.13 **Trench 142.** Sample 14 from fill 14206 of pit 14205 produced a large flot. A significant portion of the charcoal is roundwood in the form of twig fragments, some up to 8mm in diameter and 4–5cm in length. The grain is a mixture of wheat and barley, with wheat glume bases and barley rachis also recovered. The weed assemblage includes dock seeds (*Rumex* sp.) and a number of small Fabaceae, likely vetches. Burnt flint, pottery and fired clay were recovered from the residue. The deposit is dated to the middle Roman period.
- C.1.14 **Trench 143.** Sample 9 from fill 14310 of ditch 14309 produced a modest flot. The main component of the flot is a terrestrial mollusc assemblage. Bone and slag were recovered from the residue.
- C.1.15 **Trench 148.** Sample 2 from fill 14805 of pit 14804 produced a poor flot. All material is <2mm in size, with a speedwell seed and some small vetch fragments being identified. Burnt flint and fired clay were recovered from the residue. The feature is dated to the early Roman period.

## Discussion

- C.1.16 In general, there is good potential for the recovery of charred material on site. Material from ditches 3303, 4605 and pit 14205 are all good candidates for further analysis and will contribute to the final narrative for the site. There are also viable samples from each of the cremation cuts that can undergo further analysis for species identification. Twig roundwood in several samples offer opportunities for 14C dating, should it be required.

Sample no.	Context no.	Feature/ deposit	Date	Sample vol. (L)	Flot vol. (ml)	Charcoal >2mm	Grain	Chaff	Weeds	Molluscs	Other	Notes
1	3304	3303	RB	40	50	++	+++	+++	++			10YR 5/2 silty clay
2	14805	14804	ERB	3	5				+		+	7.5YR 4/4 sandy clay loam
3	11303	11302		16	25	++						10YR 4/4 sandy silt loam
4	13611	13610		40	200	++++			+			7.5YR 3/2 sandy silt loam
5	13611	13610		35	150	++++	+					7.5YR 3/2 sandy silt loam
6	13611	13610		10	25	+++						7.5YR 3/2 sandy silt loam
7	13611	13610		10	5	+						7.5YR 3/2 sandy silt loam
8	13612	13609		40	200	++++			++			7.5YR 3/4 silt loam
9	14310	14309		40	50	++				+++		7.5YR 4/6 loamy sand
10	13614	13613		4	50	+++			+			10YR 3/3 sandy silt loam
11	13612	13609		30	150	++++			+			10YR 3/3 sandy silt loam
12	13612	13609		30	200	++++			+			10YR 3/4 sandy silt loam
13	13614	13613		5	25	+++						10YR 4/4 sandy silt loam
14	14206	14205	LIA–MRB	18	210	++++	++	+	+++			7.5YR 3/2 sandy loam
15	13612	13609		20	50	+++			+			10YR 3/4 sandy silt loam
16	13614	13613		8	20	++			+			7.5YR 4/4 sandy silt loam
17	13614	13613		5	5	++						7.5YR 4/4 sandy silt loam
18	13612	13609		5	10	++						10YR 3/3 sandy silt loam
19	13614	13613		4	5	+			+	+		10YR 4/6 sandy silt loam
20	13612	13609		3	10	++			+			7.5YR 3/4 sand
21	13615	13609		10	10	+			+			10YR 4/3 sandy silt loam
22	10205	10203	IA	18	25	++						7.5YR 5/4 silty clay loam
23	13614	13613		8	10	+			+			7.5YR 4/6 sand
24	13612	13609		20	10	++			+			7.5YR 4/6 sand
25	7604	7614	LIA–MRB/Sax	36	375	++++	++		+			7.5YR 4/4 loamy sand
26	4606	4605		38	100	++++	++++		+		+++	10YR 4/3 loamy sand

Key: +=present (up to 5 items), +=frequent (5-25), +=common (25-100), +=abundant (100+)

Table 9: Assessment of bulk samples

## C.2 Animal Bone

By Rebecca Nicholson

### Introduction and methodology

- C.2.1 An estimated total of 139 animal bone fragments (number taking into account refitting fragments that are scored as one bone), weighing 603g, was recovered from the site (Table 10**Error! Reference source not found.****Error! Reference source not found.**), all of which was collected by hand. Features on the site were dated based on associated ceramic finds, most of which were Roman, medieval or post-medieval in date. The animal bone was collected from 18 contexts recorded across Trenches 5, 42, 43, 72, 90, 104, 112, 114, 122, 142, 143, 172 and 186.
- C.2.2 The animal bone was recorded in full, with the aid of the Oxford Archaeology skeletal reference collection and standard identification guides, using a diagnostic zone system (Serjeantson 1996). Bone condition was recorded on a semi-quantitative scale of 1 (as fresh) to 5 (extremely poor, corroded and crumbly). Where condition was difficult to score (eg burnt bone and teeth), condition was recorded as 0. No bones were suitable for measurement; any complete or nearly complete bones were from young animal(s) with unfused bones. Tooth wear was recorded following Grant (1982). Full records will be lodged with the site archive.

### Description

- C.2.3 Bone preservation varies depending on trench and period but, if considered by the number of fragments exhibiting each condition, then is typically fair–good (condition 2–3). This is, however, skewed by the presence of a partially complete and well-preserved foetal calf from 11207. The bone from contexts 9003, 10403 and 10405 are extremely eroded (condition 5), and only fragments of tooth enamel were recovered from 4312. No burnt bone was recovered. A mole (*Talpa europaea*) humerus from 14310 is in extremely good condition and is very probably intrusive, as is a small mammal metapodial from 7206.
- C.2.4 Notable elements of the assemblage include the partially complete foetal calf from ditch fill 11207. The majority of bone fragments are post-cranial, some of the head, including the mandible and maxilla, is missing. All epiphyses are unfused, and there is one example where metacarpal/metatarsal III and IV have not yet fused together. This burial accounts for 14 of the identified bones, as well as an estimated 45 indeterminate fragments. Two large mammal cervical vertebrae from animals of different sizes were also recovered from the same context.
- C.2.5 No bones were butchered, and no pathologies were observed. A loose cattle M3 tooth from context 4208 is at Grant's (1982) wear stage k, equating to an elderly/senile animal (Halstead 1985, 219).

### Conclusions

- C.2.6 Animal bone is clearly present on site in the areas excavated, but it is possible that the calf from context 11207 is of later date than the ceramics within the fill, since the bone is fairly well-preserved despite being immature.

Context	Period	Cattle	Horse	Sheep/goat	Mole	Large mammal	Medium mammal	Small mammal	Indet. mammal	Total
504						1				1
4208	c 13th–15th	1								1
4312									7	7
7206								1		1
9003		1								1
10403	Roman					1				1
10405									50*	50
11207	Roman	14				2			45*	61
11403							10			10
12203						1				1
14204			1							1
14310					1					1
17205	E/M Roman						2			2
18607				1						1
<b>Total</b>		<b>17</b>	<b>1</b>	<b>1</b>	<b>1</b>	<b>4</b>	<b>12</b>	<b>1</b>	<b>102</b>	<b>139</b>

\*= small fragments, estimated number

Table 10: Animal bone assemblage, number of fragments by context and taxon

### Recommendations regarding the conservation, disposal or retention of material

- C.2.7 The bone assemblage is small and has been recorded in full. Retention in the archive is not considered to be a priority.

## C.3 Human Remains

By Helen Webb

### Introduction and provenance

- C.3.1 All deposits were recovered, processed and analysed in accordance with published guidelines (McKinley 2004).
- C.3.2 The human bone recovered from the archaeological evaluation at land bordering the A13 at Orsett, Essex (LTC3020), comprised three unurned deposits of cremated bone (13611 from pit 13610, 13612 from pit 13609 and 13614 from pit 13613). A small quantity of bone was also recovered from the primary fill (13615, sample 21) of pit 13609. This clearly originated from overlying deposit 13612, thus it is therefore included with this deposit.
- C.3.3 All three pits, which were closely adjacent to one another, were revealed within the south-eastern half of Trench 136. Immediately to the south-east of the cremation features were NE–SW aligned gully 13603 and ditch 13605.
- C.3.4 The largest of the three pits was 13610 (containing deposit 13611). This feature was roughly oval, measuring 1.10m in width with a depth of 0.20m. Deposit 13611 comprised a dark brown, loose clay-sand with charcoal, as well as fired flint fragments. Heat-affected natural was noted on the south-west edge of the feature.
- C.3.5 Pit 13613, the smallest of the three pits, measured 0.34m by 0.26m, with a depth of 0.09m. The fill (13614) comprised a soft, dark grey-black (charcoal-rich) sandy silt with frequent burnt bone. Pit 13609, immediately adjacent to the south-east of 13613, measured 0.87m by 0.65m, with a depth of 0.20m. This pit contained very dark grey-brown clayey sand, with occasional burnt flint/stone fragments and frequent charcoal. During excavation it was not clear, initially, that 13609 and 13613 were separate features, the upper fills (13612 and 13614) being mixed on the surface.
- C.3.6 All three of the pits were affected by plough truncation and this was probably the cause of the mixing of deposits 13612 and 13614. The features also suffered slight machine truncation.
- C.3.7 None of the cremation deposits yielded dating evidence, nor was any dating evidence recovered from the adjacent gully/ditch features, thus all remain undated.

### Methodology

- C.3.8 All deposits were recovered, processed and analysed in accordance with published guidelines (McKinley 2004).
- C.3.9 The deposits were subject to whole earth recovery in the field, before being processed and analysed. Each feature was excavated in a series of spits, but for the purposes of analysis the spit-data was combined for each deposit. It should be noted here that the mixed material from the initial excavation of deposits 13612 and 13614 (prior to them being identified as separate features) was treated entirely separately from the rest of the deposits.
- C.3.10 Processing involved wet sieving the deposits, which sorted them into fractions of >10mm, 10–4mm, 4–2mm and 2–0.5mm. The >10mm and 10–4mm sieve fractions were fully sorted, separating the burnt bone from the extraneous material (e.g. stones). It was not viable to fully sort the 4–2mm fractions (some of the 4–2mm



material from deposits 13612 and 13614 were sorted). Instead, a sample from each of these unsorted fractions was sorted and the percentage bone weight calculated. These percentages were then applied to the total weights of the unsorted samples to give an estimated bone weight for each. These estimated bone weights were as follows: 158.7g (deposit 13611); 63.3g (deposit 13612, in addition to 5.9g sorted); 20.8g (deposit 13614, in addition to 2.3g sorted); 34.4g (mixed deposit 13612/13614). These estimated weights are included in the total weights presented below.

- C.3.11 The smallest fraction sizes (2–0.5mm) were not sorted but were rapidly scanned for identifiable skeletal remains and artefacts. Estimations of the proportions of bone present within the 2–0.5mm fractions were made visually and are noted in the results below.
- C.3.12 All bone was analysed to record colour, weight and maximum fragment size. Total bone weights presented do not include bone from the 2–0.5mm fraction but do include the weight estimates calculated for the 4–2mm fractions.
- C.3.13 Each sieve fraction was examined for identifiable bone elements and the presence of pyre and/or grave goods. The minimum number of individuals (MNI) present was estimated based on the identification of repeated elements and/or the presence of juvenile and adult bones in the same deposit. Estimations of age were based on the development stage of tooth roots (Moorrees et al 1963; AlQahtani 2009), observations of completely fused epiphyses (Scheuer and Black 2000) and, more generally, the overall size/morphology of identified bones. No indicators of sex were identified.

## Results

- C.3.14 Full details of the osteological analysis are available in the archive.
- C.3.15 A summary of the osteological findings for each deposit is presented in Table 11. Because it was not possible to ascertain how much of the material comprising mixed deposits 13612 and 13614 came from each deposit, the data for the mixed material is presented separately.

Context	>10mm	10–4mm	*4–2mm	Total weight*	Maximum fragment size	Identified elements	Colour	MNI, age, sex
13611	375.2g (44.4%)	310.2g (36.7%)	158.7g (18.8%)	844.1g (100%)	62mm (femur shaft)	Skull vault, temporal frags (inc. petrous), maxilla, mandible, tooth roots, ribs, vertebral body/arch frags, humerus, radius, ulna, hand phalanx (prox), innominate, femur, patella, tibia, fibula	White 100%	MNI = 1 Adult/adolescent (>13 yrs) ?sex
**13612	310.7g (56.7%)	168.0g (30.7%)	69.2g (12.6%)	547.9g (100%)	61mm (?tibia shaft)	Skull vault, maxilla, vertebral arch frags, sacrum, ribs, humerus, radius, ulna, carpal frag, hand phalanges, innominate, femur, patella, tibia, fibula, lateral cuneiform, metatarsal frags, foot sesamoid	White 99% Grey 1%	MNI = 1 Adult/adolescent (>13 yrs) ?sex
13614	49.9g (42.4%)	44.7g (38.0%)	23.1g (19.6%)	117.7g (100%)	47mm (clavicle)	Skull vault, loose sutural ossicle, temporal bone, maxilla, mandible (inc. L + R ramus, condyle frag), vertebral arch frags (inc. cervical vertebra), ribs, clavicle	White 100%	MNI = 1 Adult/adolescent (>13 yrs) ?sex
Mixed deposit (upper portions of 13612/13614)	81.8g (35.7%)	113.2g (49.3%)	34.4g (15.0%)	229.4g (100%)	50mm (?humerus shaft)	Skull vault, temporal bone (inc. petrous frag), maxilla, tooth roots (at least x4 teeth), vertebral arch frags, ribs, scapulam humerus, radius (inc. head frag), distal hand phalanx, femur, tibia, fibula, distal foot phalanx	White 100%	MNI = 1 Adult/adolescent (>13 yrs) ?sex

\*All 4–2mm and total weights include the estimated 4–2mm weights (see Methods)

\*\*Weights for 13612 include the small quantity of bone from primary fill 13615 (4–2mm only)

Table 11: Summary of osteological findings

### *Bone weights*

- C.3.16 At 844.1g, the total weight of deposit 13611 falls well below the expected range for modern cremation deposits (1000–2400g, with an average of 1650g, McKinley 2000, 269). However, it does fall within the range for archaeologically recovered cremation deposits (600–900g, McKinley 2013, 154). It should be reiterated here that the deposit was affected by plough truncation, as well as probable slight machine truncation, and it is not known how much of the deposit may have been lost.
- C.3.17 Discrete deposit 13612 totalled 547.9g, whilst discrete deposit 13614 weighed just 117.7g. The mixed deposit, comprising a combination of the upper fills of 13612 and 13614, totalled 229.4g. As noted above, it was not possible discriminate between material from 13612 and 13614 within the mixed deposit, thus the total weights of each remain inconclusive. Furthermore, these features were also subject to plough, and probably also machine, truncation.

### *Fragmentation*

- C.3.18 In all three deposits, as well as the mixed material from 13612/13614, the largest proportions of bone were from the >10mm fractions. In deposit 13611, 44.4% of the total weight comprised fragments that were >10mm, compared with 56.7% in deposit 13612, 42.4% in deposit 13614 and 35.7% in mixed deposit 13612/13614. The smallest proportions of bone in all deposits, came from the 4–2mm fractions (18.8% in 13611, 12.6% in 13612, 19.6% in 13614 and 15.0% in the mixed material from 13612/13614).
- C.3.19 The largest bone fragments from each deposit were a 62mm length of femur shaft (13611), a 61mm length of probable tibia shaft (13612), a clavicle fragment measuring 47mm (13614) and a probable humerus shaft fragment measuring 50mm (mixed deposit 13612/13614).
- C.3.20 The unsorted 2–0.5mm residues all contained low, or very low, quantities of bone. Based on visual assessment, the estimated bone content (by volume) ranged from c 1% (discrete deposits 13612 and 13614, and mixed material from 13612/13614) to 5% (deposit 13611).

### *Skeletal Representation*

- C.3.21 Table 12 outlines the bone weights per skeletal region (skull, axial, upper limb, lower limb) as well as the unidentified bone weight, per deposit.

Element/Context	13611	13612	13614	Mixed deposit (13612/13614)
Skull	150.0g (17.8%)	0.6g (0.1%)	66.5g (56.5%)	23.1g (10.1%)
Axial	27.9g (3.3%)	23.3g (4.3%)	3.3g (2.8%)	3.0g (1.3%)
Upper limb	58.5g (6.9%)	66.6g (12.2%)	3.2g (2.7%)	28.2g (12.3%)
Lower limb	112.5g (13.3%)	111.8g (20.4%)	/ (0%)	15.9g (6.9%)
Total identified	348.9g (41.3%)	202.3g (36.9g)	73.0g (62.0%)	70.2g (30.6%)
Unidentified	495.2g (58.7%)	345.6g (63.1%)	44.7g (38.0%)	159.2g (69.4%)
<b>Total</b>	<b>844.1g (100%)</b>	<b>547.9g (100%)</b>	<b>117.7g (100%)</b>	<b>229.4g (100%)</b>

Table 12: Bone weights per body region

- C.3.22 Of the total weight, 41.3% (348.9g) of deposit 13611 could be identified to skeletal element. Skull fragments, including cranial vault, temporal bone fragments (including a petrous fragment), maxilla, mandible, tooth roots, made up 17.8% of the total bone weight, or 43% (150.0g/348.9g), of the identified bone weight. Skull fragments often

make up a significant proportion of identified bone weights because they are easily identifiable, even amongst the smaller fractions. Lower limb bone fragments, including innominate, femur, patella, tibia and fibula fragments, made up the next largest proportion of identified bone (13.3% of the total deposit weight, or 32.2% (112.5g/348.9g) of the identified bone). Upper limb bone fragments (humerus, radius and ulna fragments, and a proximal hand phalanx) and axial bone fragments (ribs and vertebral body/arch fragments) made up far smaller proportions of the identified bone (16.8% (58.5g/348.9g) and 8.0% (27.9g/348.9g) respectively). Axial bone fragments often make up only a small proportion of the total bone weight, not only because they weigh proportionally less within a complete skeleton, but because they are made up largely of trabecular (spongy) bone, which does not survive as well in the burial environment. Unidentified bone fragments made up over half (58.7%) of the total weight of the deposit, and almost 30% of the unidentified bone comprised unidentified long bone fragments, a common finding in archaeological cremation deposits.

- C.3.23 The distribution of bone by skeletal region within deposits 13612 and 13614 is interesting. Whilst the mixing of the upper parts of these deposits precludes any firm conclusions to be made regarding the proportions of bone per skeletal region (i.e. because it is unclear how much of each skeletal region identified within the mixed material relates to either deposit 13612 or deposit 13614), it is notable that only a very small quantity of skull fragments (including cranial vault and maxilla) was identified in discrete deposit 13612 (0.6g, making up 0.1% (0.6g/547.9g) of the total weight, or 0.3% (0.6g/202.3g) of the identified bone weight). Conversely, the majority of the identified bone in discrete deposit 13614 actually comprised skull fragments (66.5g, making up 56.5% (66.5g/117.7g) of the total weight, or 87.5% (66.5g/73.0g) of the identified bone weight). These included cranial vault fragments, a loose sutural ossicle, temporal bone fragments, maxilla and mandible fragments (including left and right ramus, and a condyle fragment). Further, the identified bone from deposit 13612 largely comprised lower limb bone fragments (111.8g, making up 20.4% (111.8g/547.9g) of the total weight, or 55.3% (111.8g/202.3g) of the identified bone weight), including femur, patella, tibia and fibula fragments, a partial lateral cuneiform, metatarsal fragments and a probable foot sesamoid. No lower limb bone fragments were identified in 13614 at all. All skeletal regions were represented within the mixed material from deposits 13612 and 13614.

#### *Colour of the cremated bone*

- C.3.24 The colour of cremated bone reflects the degree of oxidation and is thus an indication of the efficiency of the cremation, in terms of the quantity of fuel used to build the pyre, the temperature attained in various parts of the pyre, and the length of time over which the cremation was undertaken (McKinley 2004, 11). Colour may range from brown/orange (unburnt), to black (charred: c 300°C), through hues of blue and grey (incompletely oxidised, up to c 600°C) to white (fully oxidised, >600°C) (*ibid.*).
- C.3.25 The burnt bone from all deposits was completely white (calcined), with the exception of a few fragments (c 1%) in deposit 13612, which were light grey in colour. Amongst the grey coloured fragments was a distal hand phalanx.

#### *Demography*

- C.3.26 In the absence of any obvious repeated elements, the minimum number of individuals (MNI) represented in each deposit was one.

C.3.27 In all three discrete deposits (13611, 13612, 13614), the size, thickness and morphology of the bones was in keeping with adult, or possibly adolescent, remains. although there were no precise indicators of age. In deposit 13611 and mixed deposit 13612/13614 a number of tooth roots were observed. Most of these were incomplete/fragmented, and therefore unidentified, but where the apices were observable, these were all complete. No more precise indicators of age were present within the deposits, nor were there any indicators of sex.

#### *Pathology and non-metric traits*

C.3.28 Non-metric traits are minor anomalies of skeletal anatomy that may be environmentally or genetically induced (Mays 1998; Tyrrell 2000). The only non-metric trait observed was a loose sutural ossicle within deposit 13614. Some variations in the sutures of the skull, such as lambdoid ossicles, have been proven to be under significant genetic control (Torgersen 1951a; 1951b; 1954; Sjøvold 1987).

C.3.29 No lesions of pathology were observed.

#### *Pyre/grave goods*

C.3.30 No evidence for pyre or grave goods was identified within any of the deposits.

### **Discussion**

C.3.31 The human bone assemblage comprised three unurned cremation deposits (13611, 13612, 13614) from earth-cut pits, as well as a deposit collected separately, comprising the mixed upper fills of deposits 13612 and 13614. All deposits were undated.

C.3.32 Each of the deposits had an MNI of one, and in all cases the remains were in keeping with adult, or possibly adolescent, remains, although no precise age, or sex, estimations could be made. No pathological lesions were observed.

C.3.33 With a total weight of 844.1g, deposit 13611 was the largest. This also came from the largest of the pit features (1.1m wide). Although the weight falls within the range expected for archaeologically recovered deposits (600–900g, McKinley 2013, 154), it is unknown how much bone may have been lost as a result of disturbance/truncation. Aside from cremated bone, it is clear that the deposit also included pyre debris, with the surrounding matrix also including charcoal and burnt stone fragments. The observation, during excavation, that the natural around the south-western edge of the deposit was heat-affected, indicates that the remains were still very hot when they were deposited, presumably having been tipped into the pit from this side. It was considered that the feature may have represented the very base of an *in situ* cremation pyre pit, the upper part having been truncated by plough/machine, but this seems unlikely given that only the south-western edge of the remaining feature exhibited evidence for heating.

C.3.34 Interpretation of deposits 13612 and 13614 is difficult. As noted above, the upper fills were mixed on the surface, it only becoming apparent that there were two separate features as the upper parts of the deposits were removed. The total weights of the discrete deposits were 547.9g (13612) and 117.7g (13614), both below the expected range for archaeologically recovered cremation deposits (see above, McKinley 2013, 154). However, a significant quantity of bone (229.4g) was recovered from the mixed material and it is not known how much of this derived from each deposit.

- C.3.35 When the proportions of each skeletal region represented within the discrete deposits (13612 and 13614) were calculated, an interesting pattern was noted. An unusually low proportion of skull fragments was noted in deposit 13612, compared with a notably high proportion of skull fragments within deposit 13614. Conversely, a notably high proportion of lower limb bones was identified in deposit 13612, with no lower limb bones positively identified within 13614 at all. It is, of course, unclear how the quantities of skull and lower limb bone fragments within the mixed material from these deposits would affect these figures, but it is tempting to suggest that the two features may in fact contain remains from the same individual, the different skeletal regions being split between the features. It is assumed that the mixing of deposits 13612 and 13614 simply occurred due to plough disturbance of two closely adjacent pits. Whilst this seems like the most likely scenario, it should not be discounted that the apparently separate features were in fact all that remained of a single feature, appearing falsely as separate features due to a markedly undulating base and the sides of the pit largely being lost due to truncation by ploughing. If this were the case, then the observed patterns in skeletal representation between deposits 13612 and 13614 would indicate that the remains had been placed in some sort of order within the feature.
- C.3.36 As with 13611, both 13612 and 13614 contained charcoal and burnt stone, indicating that pyre debris formed part of the deposit/s. The south-western edge of pit 13609 (containing 13612) also comprised heat-affected natural, as seen in pit 13610 (containing 13611). As noted above, this indicates that the material was hot when it was deposited. If none of these features are *in situ* pyre pits (indeed, the archaeology does not seem to support this), then the pyre site/s must have been nearby, the remains having been buried quickly after the end of the cremation process.
- C.3.37 Overall, the bones from all deposits were predominantly white (fully oxidised). This indicates that the corpse/s would have been placed on the pyre in such a way as to maintain a consistent high temperature and oxygen supply (McKinley 2013, 158), enabling a temperature in excess of 600°C (McKinley 2004, 11). A high proportion of fully oxidised bone is a common observation in archaeological cremation burials (McKinley 2006, 84). The few non-white fragments in deposit 13612, representing lower temperatures, included a hand phalanx and it may be that these elements were closer to the edges of the pyre, where such high temperatures had perhaps not been reached.
- C.3.38 It is recommended that these remains are retained for future research, given the potential for further works in the surrounding area, at which point it may be beneficial to carry out radiocarbon dating. Dating would allow for further discussion of their significance in the archaeological record. All deposits have suitable fragments for dating.
- C.3.39 The assemblage is currently held at Oxford Archaeology under Ministry of Justice burial licence 19-0317. This licence is valid until 8th December 2025, by which time the remains must have been reburied. In the event that the remains are not ready for reburial by this time the licence should be deferred by application to the Ministry of Justice. Deferring the licence so that the human bone can be deposited with a local museum is recommended, considering the future research potential.

- ACBMG, 2007 *Ceramic building material, minimum standards for recovery, curation, analysis and publication*, Archaeological Ceramic Building Materials Group
- Bamford, H, 1985 *Briar Hill: excavation 1974–1978*. Northampton: Northampton Development Corporation Archaeol Monogr **3**
- BGS, 2020 *Geology of Britain Viewer*. Retrieved from <http://mapapps.bgs.ac.uk/geologyofbritain/home.html>
- Biddulph, E, 2010 The Roman pottery, in E. Biddulph, K. Brady, B. M. Ford and P. Murray, Roman settlement, pottery production and a cemetery in the Beam valley, (Dagenham), *Trans Essex Soc Archaeol Hist* **1**, 121–9
- Biddulph, E, 2015 Pottery production at Heybridge, in M. Atkinson and S. J. Preston, Heybridge: a late Iron Age and Roman settlement, excavations at Elms Farm 1993–5, volume 2. *Internet Archaeology* **40**, <http://dx.doi.org/10.11141/ia.40.1.biddulph>
- Biddulph, E, Compton, J, and Martin, T S, 2015 The late Iron Age and Roman pottery, in in M. Atkinson and S. J. Preston, Heybridge: a late Iron Age and Roman settlement, excavations at Elms Farm 1993–5, volume 2. *Internet Archaeology* **40**, <http://dx.doi.org/10.11141/ia.40.1.biddulph1>
- Bettley, B and Pevsner, N, 2007 *The Buildings of England, Essex*
- Bonsall, C, 1978 The flint industry, in J. Hedges and D. Buckley, Excavations at a Neolithic causewayed enclosure, Orsett, Essex, 1975. *Proc Prehist Soc* **44**, 255–9
- Brudenell, M, 2016a Late Bronze Age pottery, in Evans *et al.* 2016, 158–88
- Brudenell, M, 2016b Middle Iron Age pottery, in Evans *et al.* 2016, 365–93
- Butler, C, 2005 *Prehistoric flintwork*. Stroud: Tempus
- Carter, G, 1998 Excavations at the Orsett 'Cock' Enclosure, Essex, 1976. Essex County Council: East Anglian Archaeology 86
- CIfA, 2014a *Standard and guidance for archaeological evaluation*. Updated October 2020. Chartered Institute for Archaeologists. Retrieved from <http://archaeologists.net/sites/default/files/node-files/IfASG-Evaluation.pdf>
- CIfA, 2014b *Standard and guidance for the creation, compilation, transfer and deposition of archaeological archives*. Revised October 2020. Chartered Institute for Archaeologists. Retrieved from: [https://www.archaeologists.net/sites/default/files/CIFAS%26GArchives\\_4.pdf](https://www.archaeologists.net/sites/default/files/CIFAS%26GArchives_4.pdf)
- Cheer, P, 1998 The kiln pottery, in G. A. Carter, *Excavations at the Orsett 'Cock' enclosure, Essex, 1976*, E Anglian Archaeol **86**. Chelmsford: Essex County Council, 97–101

- Cotter, J P, 2000 *Post-Roman pottery from excavations in Colchester 1971–1985*. Colchester: Colchester Archaeological Report **7**
- English Heritage, 2015 *Management of Research Projects in the Historic Environment: The MoRPHE Project Managers' Guide*. Swindon: Centre for Archaeology Guidelines
- Evans, C, Appleby, G and Lucy, S, 2016 *Lives in the land: Mucking excavations by Margaret and Tom Jones, 1965-1978. Prehistory: context and summary*. Cambridge Archaeological Unit Landscape Archives Series: Historiography and Fieldwork 2/Mucking 6. Oxford: Oxbow Books
- Going, C J, 1987 *The Mansio and other sites in the south-eastern sector of the Caesaromagus: the Roman pottery*. London: CBA Res Rep **62**
- Grant, A, 1982 The use of tooth wear as a guide to the age of domestic ungulates, in B. Wilson, C. Grigson and S. Payne (eds), *Ageing and sexing animal bones from archaeological sites*. Oxford: BAR Brit Ser **109**, 91–108
- Halstead, P, 1985 A study of mandibular teeth from Romano-British contexts at Maxey, in: F. Pryor, C. French, D. Crowther, D. Gurney, G. Simpson and M. Taylor (eds), *The Fenland Project: archaeology and environment in the Lower Welland Valley, volume 1*, E Anglian Archaeol **27**. Cambridge: Cambridgeshire Archaeological Committee, 219–24
- Harrison, E, 2000 Pottery and fired clay, in E. Guttmann and J. Last, A late Bronze Age landscape at South Hornchurch, Essex. *Proc Prehist Soc* **66**, 337–44
- Healey, E, 2016 The worked flint, in Evans *et al.* 2016, 52–66
- Healy, F, 1988 *The Anglo-Saxon cemetery at Spong Hill, North Elmham, part VI: occupation during the seventh to second millennia BC*, E Anglian Archaeol **39**. Norfolk: Norfolk Archaeological Unit
- Hedges, J and Buckley, D G, 1978 Excavations at a Neolithic causewayed enclosure, Orsett, Essex, 1975. *Proc Prehist Soc* **44**, 219–308
- Highways England, 2018 Lower Thames Crossing: A Scheme Wide Specification for Archaeological Trial Trenching: unpublished document HE540039-CJV-GEN-GEN-SPE-HER-00001draft, Revision 1.05
- Inizan, M-L, Reduron-Ballinger, M, Roche, H and Tixier, J, 1999 *Technology and terminology of knapped stone*. Nanterre: Cercle de Recherches et d'Etudes Préhistoriques, CNRS
- Jefferies, R and Lucy, S, 2016 Romano-British pottery, in S. Lucy and C. Evans, *Romano-British settlement and cemeteries at Mucking: excavations by Margaret and Tom Jones, 1965–1978*. Cambridge Archaeological Unit Landscape Archives Series: Historiography and Fieldwork 3/Mucking 5. Oxford: Oxbow Books, 154–99
- Mays, S, 1998 *The archaeology of human bones*, London, Routledge



- McKinley, J I, 2000 Cremation burials, in B. Barber and D. Bowsher, *The eastern cemetery of Roman London. Excavations 1983-1990*, MoLAS Monogr **4**, 264–77
- McKinley, J I, 2004 Compiling a skeletal inventory: cremated human bone, in M. Brickley and J. I. McKinley (eds), *Guidelines to the standards for recording human remains*, IFA Paper No. **7**, BABAO and IFA, Southampton and Reading, 9–13
- McKinley, J I, 2006 Cremation...the cheap option?, in C. Knusel and R. Gowland (eds) *The social archaeology of funerary remains*, Oxford, Oxbow Books, 81-8
- McKinley, J I, 2013 Cremation: excavation and analysis, in S. Tarlow and L. Nilsson Stutz (eds) *The Oxford Handbook of the archaeology of death and burial*, Oxford, Oxford University Press, 147–72
- Medlycott, M (ed.), 2011 *Research and archaeology revisited: a revised framework for the East of England*, E Anglian Archaeol Occas Paper **24**. Association of Local Government Archaeological Officers
- MOLA, 2014 *London medieval and post-medieval pottery codes*. Museum of London Archaeology. <http://www.mola.org.uk/medieval-and-post-medieval-pottery-codes> (accessed 11 Jan 2019)
- Oxford Archaeology, 2019a Lower Thames Crossing scheme-wide written scheme of investigation for trial trenching south of the River Thames
- Oxford Archaeology, 2019b Lower Thames Crossing scheme-wide written scheme of investigation for trial trenching north of the River Thames
- Oxford Archaeology, 2020a Lower Thames Crossing detailed written scheme of investigation for trial trenching of Land Parcels 3 (north), 30–35 and 103–107
- Oxford Archaeology, 2020b Lower Thames Crossing archaeological evaluation report for trial trenching of Land Parcel 3, Hornsby Lane, Orsett Heath, Essex
- Palmer, J J, 2019 Open Domesday. <https://opendomesday.org/place/>: University of Hull
- PCRG, SGRP, MPRG, 2016 *A standard for pottery studies in archaeology*, Prehistoric Ceramics Research Group, Study Group for Roman Pottery and Medieval Pottery Research Group
- Place Services, 2019 Lower Thames Crossing aerial investigation and mapping report, Essex County Council
- Serjeantson, D, 1996 Animal bone, in S. Needham and T. Spence (eds), *Runnymede Bridge research excavations, volume 2: refuse and disposal at Area 16 East, Runnymede*. London: British Museum Press, 194–223
- Scheuer, L and Black, S, 2000 *Developmental Juvenile Osteology*. Oxford, Elsevier Academic Press

- Sjøvold, T, 1987 Decorated skulls from Hallstatt, Austria: the development of a research project, in G Burenhult, A Carlsson, A Hyenstrand and T Sjøvold (eds) *Theoretical approaches to artifacts, settlement and society*, BAR Int Ser **366**, Oxford, 5-21
- Subterranea Britannica, 2019 <https://www.subbrit.org.uk/orsett-roc-post/>
- Tomber, R and Dore, J, 1998 *The national Roman fabric reference collection: a handbook*. London: MOLAS Monogr **2**
- Torgersen, J H, 1951a. The developmental genetics and evolutionary meaning of the metopic suture, *American J Physical Anthropol* **9**, 193–205
- Torgersen, J H, 1951b Hereditary factors in the sutural patterns of the skull, *Acta Radiologica* **36**, 374–82
- Torgersen, J H, 1954 The occiput, the posterior cranial fossa and the cerebellar anatomy, in J. Jansen and A. Brodal (eds), *Aspects of cerebellar anatomy*, Gundersen, Oslo, 396–418
- Tyrrell, A, 2000 Skeletal assessment of non-metric traits and the assessment of inter- and intra-population diversity: past problems and future potential, in M Cox and S Mays (eds) *Human osteology in archaeology and forensic science*, Greenwich Medical Media, London, 289–306
- Wilkinson, T J, 1988 Archaeology and Environment in South Essex: Rescue Archaeology on the route of the A13 Grays By-pass, 1979/80. *East Anglian Archaeology* 42

## Appendix E      Abbreviations and Glossary

---

**ADS** Archaeology Data Service. Digital archaeological archive

**CDM** Construction Design Manual. Health and safety guidance for the construction industry

**CPD** Continuing Professional Development

**CIfA** Chartered Institute for Archaeologists

**DBA** Desk Based Assessment. Detailed assessment of archaeology and other aspects of the historic environment

**DCO** Development Consent Order

**EIA** Environmental Impact Assessment. Detailed study of environmental impacts as directed under the Town and Country Planning (Environmental Impact Assessment) Regulations 2017 following on from EU Directive EIA Directive (85/337/EEC)

**ES** Environmental Statement. The principal environmental report detailing environmental impacts within an EIA

**GPS** Global Positioning System

**HER** Historic Environment Record

**LTC** Lower Thames Crossing

**MCIfA** Member of the Chartered Institute for Archaeologists

**MoRPHE** Management of Research Projects in the Historic Environment

**NMP** National Mapping Programme. A study of aerial photographs and digitisation of resulting data into GIS. Originally funded by Historic England

**OASIS** Online Access to the Index of archaeological investigations.  
The OASIS project brings together a number of strategic partners: the Archaeology Data Service, Historic England, Historic Environment Scotland, and the Royal Commission on the Ancient and Historical Monuments of Wales under the umbrella of the University of York

**OCN** Old County Number. Historic England's reference for material that is not readily-available online and may represent historic archaeological work that consists of paper archives or has yet to be formally reported on

**PINS** Planning Inspectorate

**RAMS** Risk Assessment Method Statement

**SMC** Scheduled monument consent

**TDR** Trusted Digital Repository

**UKIC** United Kingdom Institute for Conservation

**WSI** Written Project of Investigation. A detailed method statement for archaeological work

**WSL** – Western Southern Link  
The Western Southern Link (WSL) is an alternative for Short List Routes 2, 3 and 4 to the south of the River Thames.

## Appendix F Site Summary

---

<b>Site name:</b>	Lower Thames Crossing Archaeological Evaluation Report for Trial Trenching of Land Parcels 3 (North), 30 and 35, Land Bordering the A13 at Orsett, Essex
<b>Site code:</b>	LTC6T20
<b>Grid Reference</b>	NGR 564149, 180821
<b>Type:</b>	Evaluation
<b>Date and duration:</b>	28th September to 27th October 2020
<b>Area of Site</b>	32.7ha

### Location of archive:

The archive from LTC3020 (Land Parcels 3, 30 and 35) will form part of the overall trial trenching scheme archive. This will be deposited in a repository consistent with the standards required by the Museums and Galleries Commission following completion of the archaeological phase of this project. This may either be with the local receiving museum in Thurrock or, if no such repositories are available, with a repository for the whole project designated by LTC. LTC retain the overall responsibility for the successful deposition of the project archive.

Currently, the archive is held at Oxford Archaeology's head office, Janus House, Osney Mead, Oxford, Oxfordshire, OX2 0ES. Oxford Archaeology will store the archive for LTC for a maximum period of two years following the completion of the project. If the storage of the archive at OA's office extends past this period, an extension to the storage period and final deposition timetable will be reviewed by OA and LTC and agreed with the major stakeholders.

### Summary of Results:

Oxford Cotswold Archaeology was commissioned by Balfour Beatty to undertake a trial trench evaluation of Land Parcels 3, 30, 31, 32, 34, 35, 103, 104 and 107 covered by WSI G of the Lower Thames Crossing Pre-Enabling Works. These Land Parcels are located either side of the A13, to the south and east of Orsett within the county of Essex and Thurrock unitary authority (NGR 564149, 180821). A total of 167 trenches were dug and recorded between 28th September and 27th October 2020 across Land Parcels 3, 30 and 35. Land Parcels 31, 32, 34, 103, 104, and 107 were not accessible during this phase of fieldwork.

The evaluation revealed a range of archaeological activity dating from the early Neolithic onwards. A single pit containing early Neolithic pottery and flint was recorded in the north-east corner of Land Parcel 30 and residual artefacts of the same date were also recovered from the same area. The evaluation revealed scattered evidence for Bronze Age and Iron Age settlement, predominantly from Land Parcel 30, but across all three parcels. This was represented by a low density of small ditches and discrete features with small quantities of finds dating to these periods, providing an indication of dispersed settlement and associated field systems through the later prehistoric period, although the limited size of the pottery assemblage and lack of diagnostic pieces has made it difficult to determine the periods of activity more precisely.

Rectilinear cropmarks indicating ditched enclosures around Heath Place and Hornsby Lane were confirmed to be Roman in date. The main phase of occupation took place from the early Roman period and peaked by the end of the 3rd century with little to no evidence that

it continued into the 4th century. Evidence from Trenches 135 to 150 revealed that the activity was well-defined within the ditched enclosures, and concentrations of pits and postholes with associated finds assemblages clearly demonstrate domestic settlement. Evidence for associated industrial activities is limited, based on the artefact assemblages and environmental evidence, but trial trenching from Hornsby Lane to the south and east has shown that these enclosures were linked to both pottery production and agricultural economies. The rectilinear system of cropmarks to the north of the A13 are likely to be of Roman date and also indicate a focus on an agricultural economy, but due to their peripheral location very few of these features provided reliable dating evidence.

Archaeological evidence for the post-Roman period was sparse and consisted of a single pit of early/middle Anglo-Saxon date in Trench 76, a medieval pit in Trench 104 and late medieval pottery from a ditch in Trench 114. During the post-medieval period, the site was almost entirely used for agricultural activity.

A large number of undated features were also recorded from across the different Land Parcels. These included three unurned cremation burials in Trench 136 but also many pits, postholes and ditches.

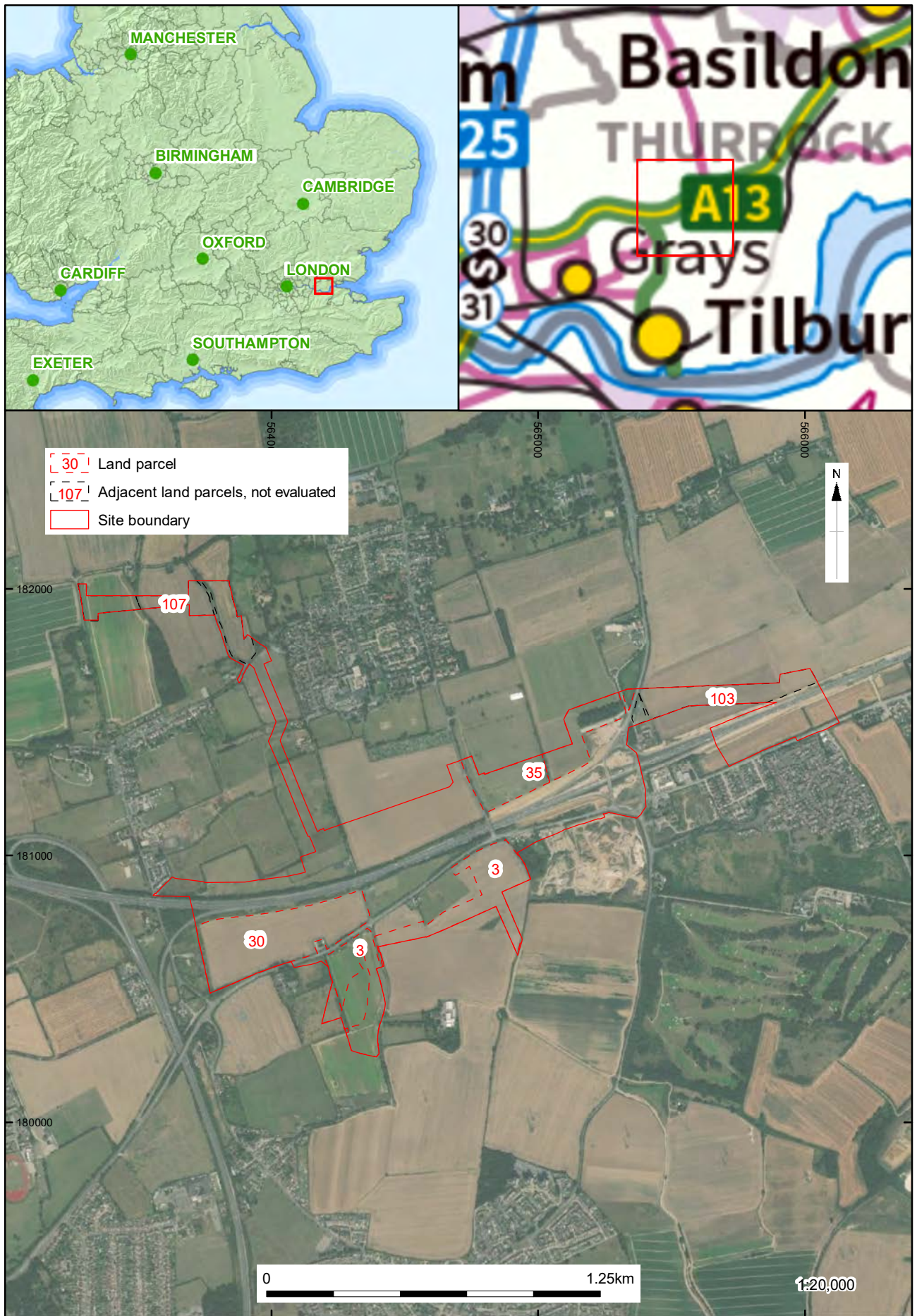
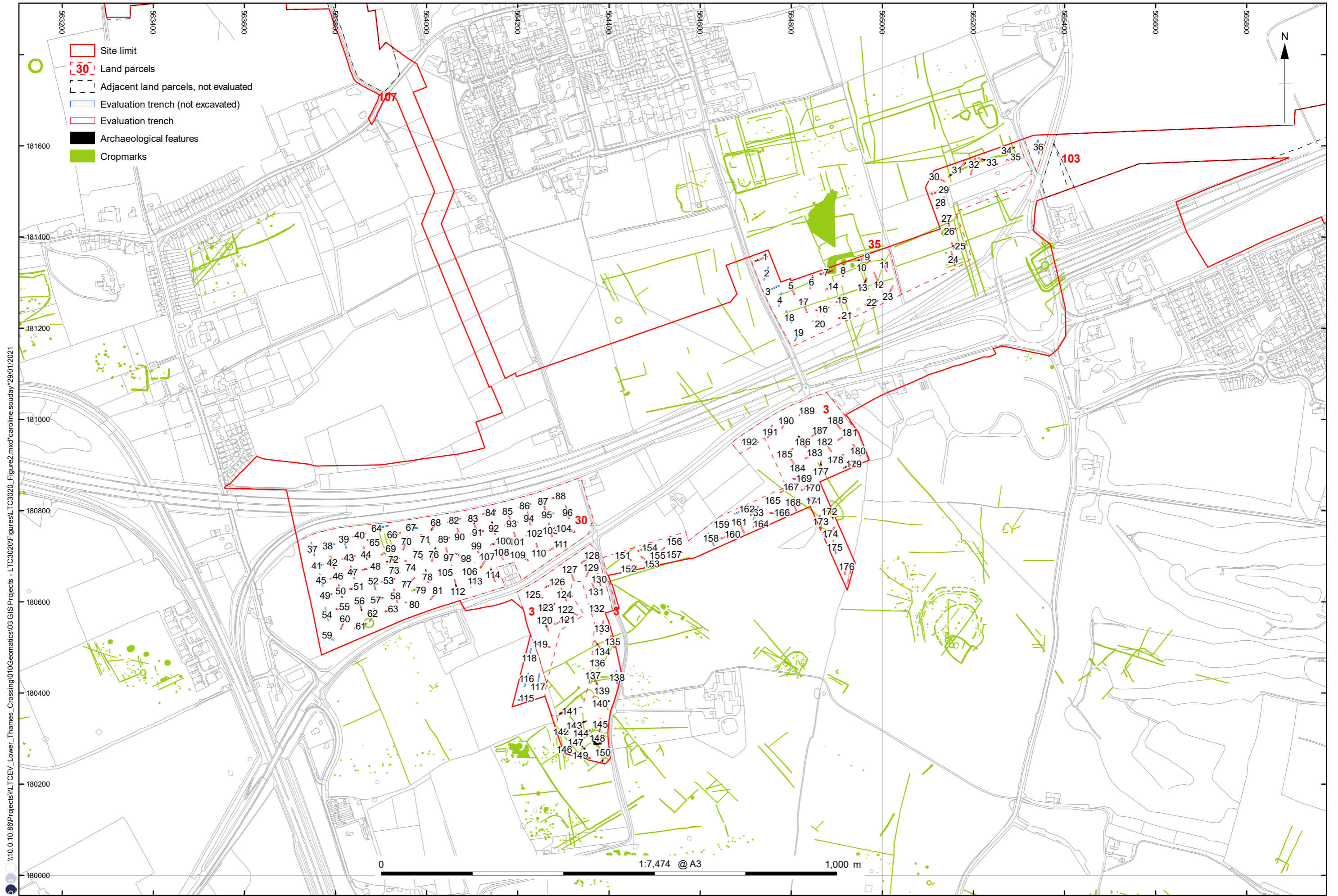

Figure 1: Site location



\\10.0.10.86\Projects\IL TCEV\_Lower\_Thames\_Crossing\010\Geomatics\03 GIS Projects - LTC3020\Figures\TC3020\_Figure2.mxd\*caroline.souday\*29/01/2021

Contains Ordnance Survey data © Crown copyright and database right 2020, provided by client

Figure 2: Trench layout and cropmark features, Land Parcels 3 (North), 30 and 35

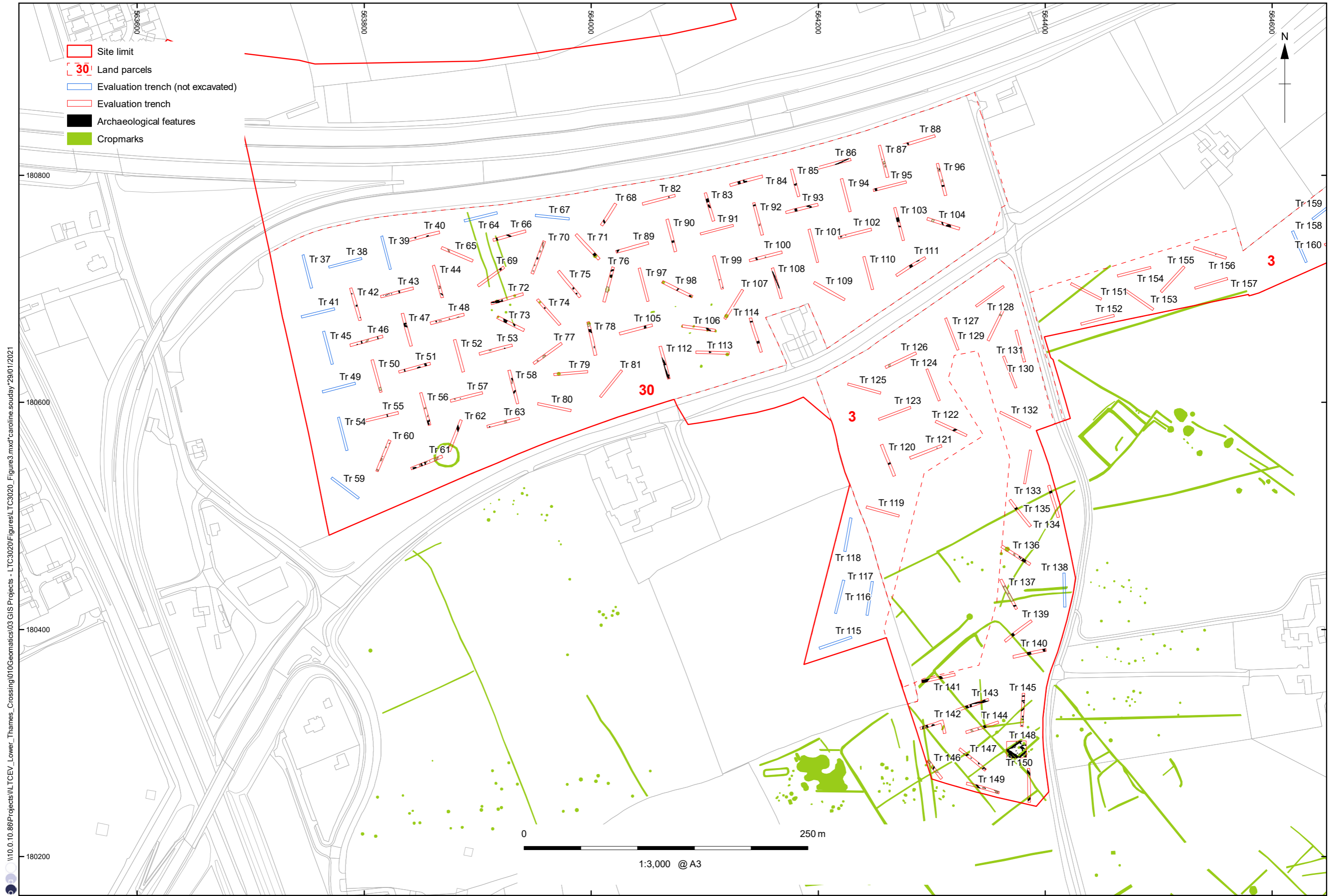

\\10.0.10.86\Projects\Lower\_Thames\_Crossing\010\geomatics\03\GIS\Projects - LTC3020\Figures\TC3020\_Figure3.mxd\*caroline.souday\*29/01/2021

Contains Ordnance Survey data © Crown copyright and database right 2020, provided by client

Figure 3: Trench layout showing archaeological features and cropmarks, Land Parcel 30 and 3 (North)



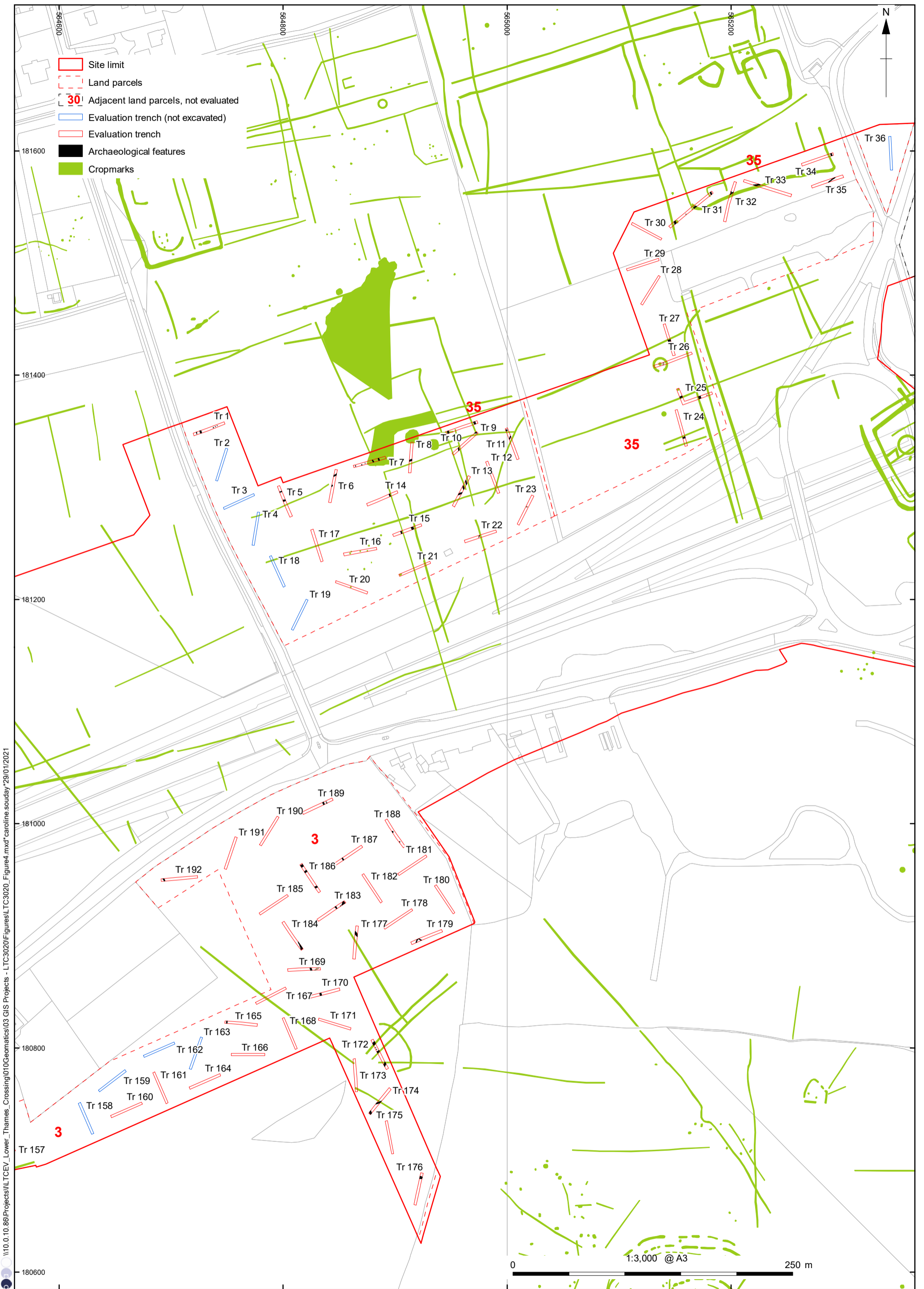

\\10.0.10.86\Projects\10.TCEV\_Lower\_Thames\_Crossing\010.Gemetrics\03 GIS Projects - LTC3020\Figures\LTC3020\_Figures4.mxd\*caroline.souday\*29/01/2021

Contains Ordnance Survey data © Crown copyright and database right 2020, provided by client

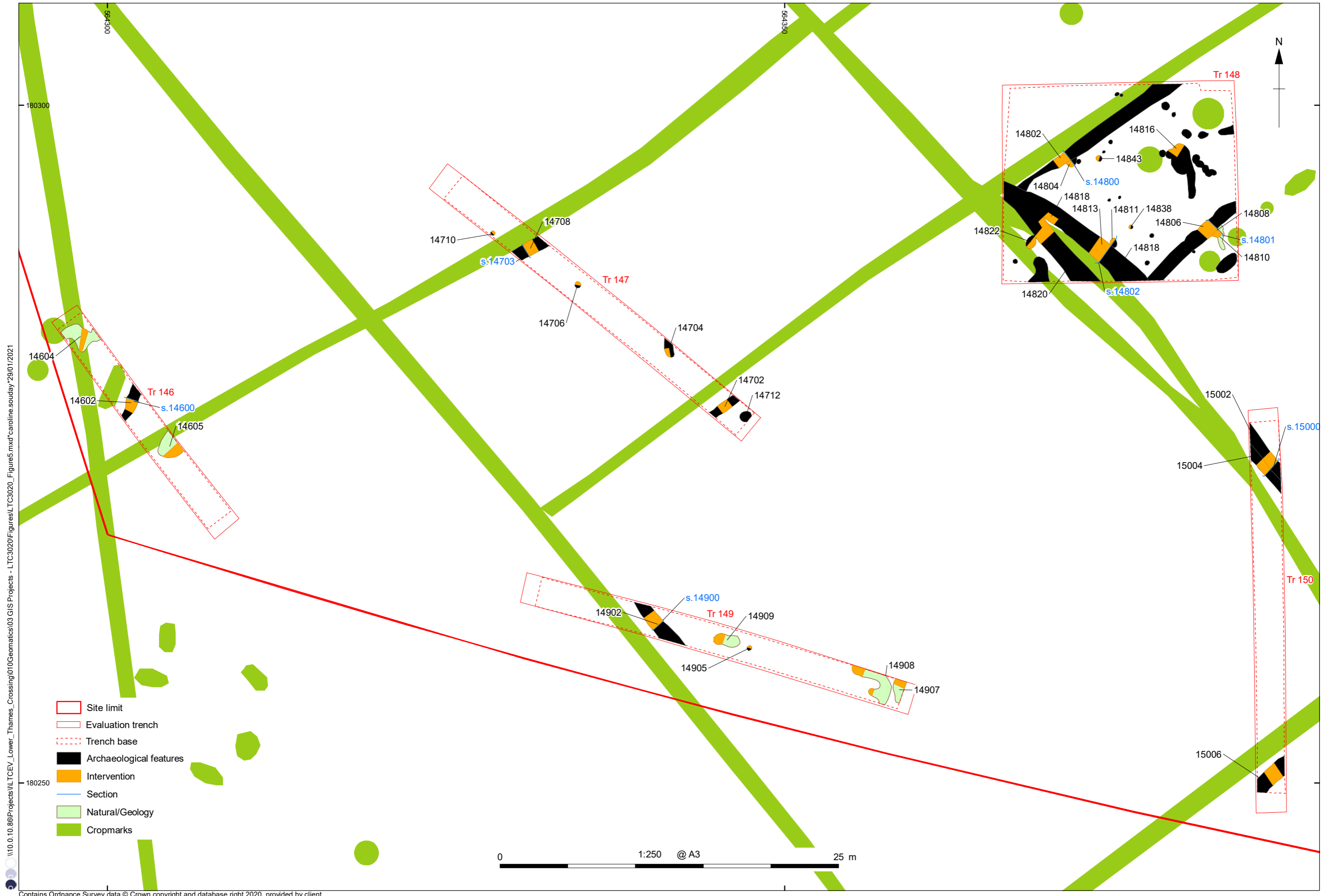

\\10.0.10.86\Projects\IL TCEV\_Lower\_Thames\_Crossing\010\ecmatics\03 GIS Projects - LTC3020\Figures\TC3020\_Figures5.mxd\*caroline.souday\*29/01/2021

Contains Ordnance Survey data © Crown copyright and database right 2020, provided by client

Figure 5: Detailed plan of Trenches 146-50

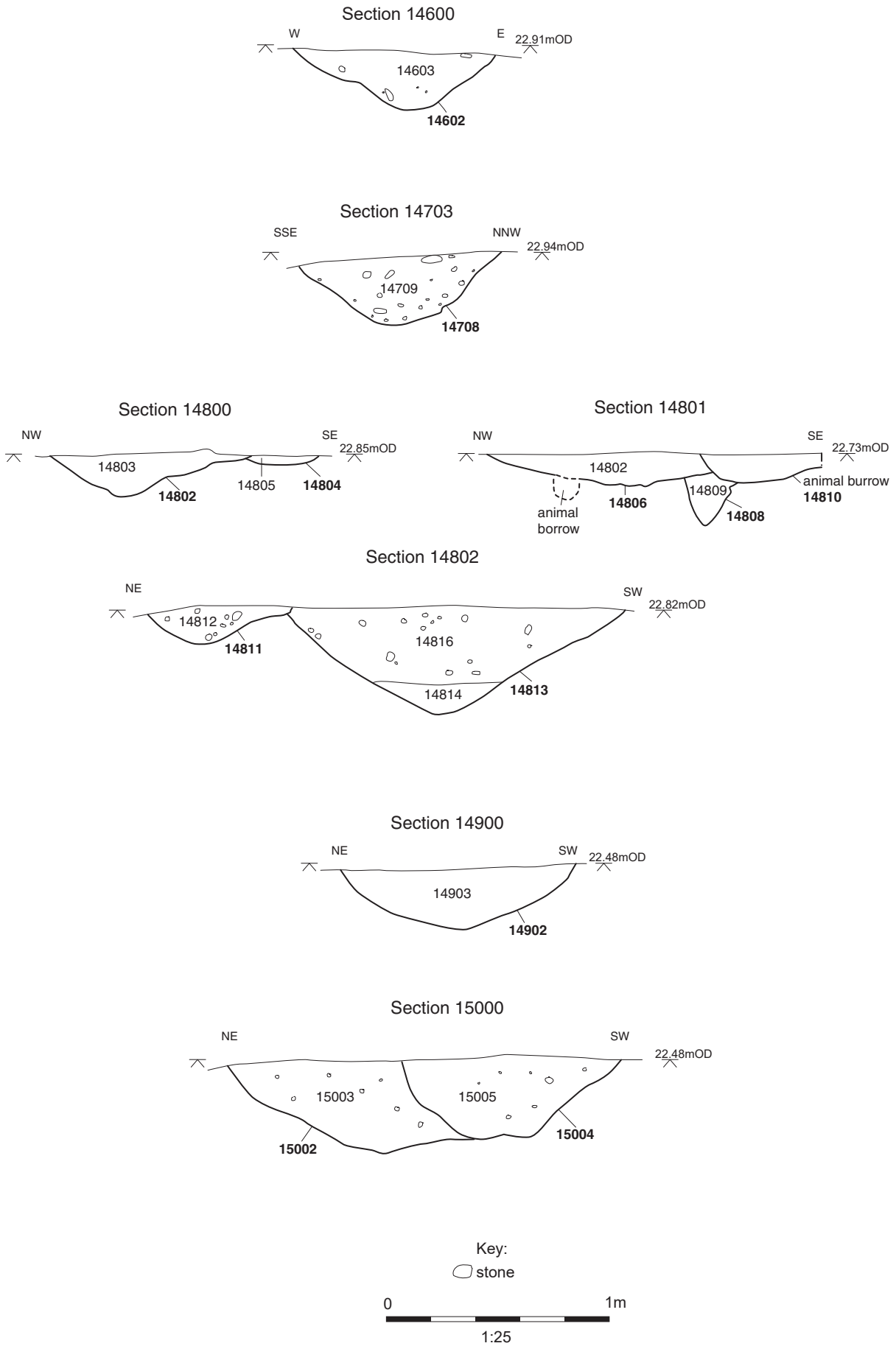
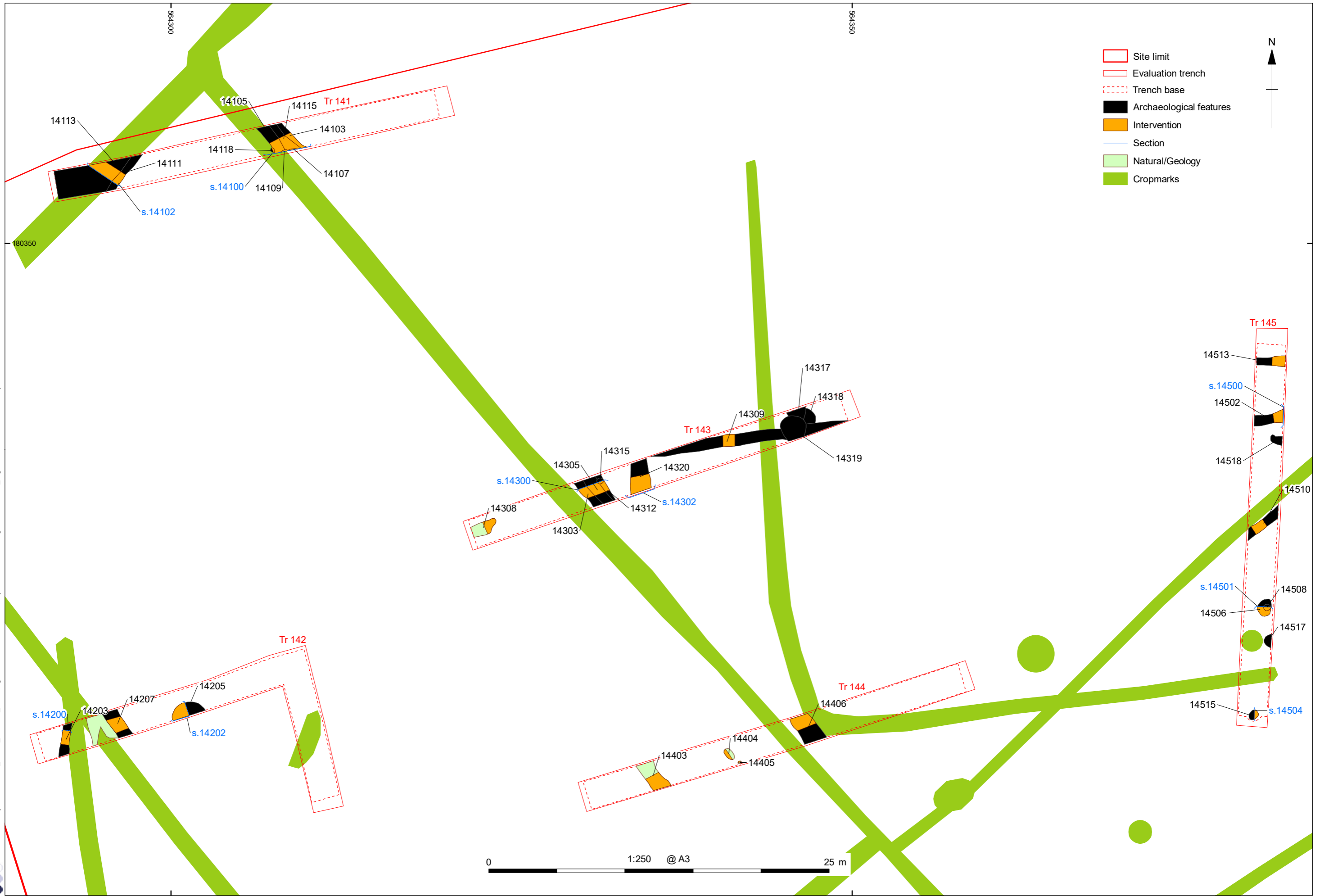

Figure 6: Sections, Trenches 146-50

\\10.0.10.86\Projects\IL TCEV\_Lower\_Thames\_Crossing\010G\emac\03 GIS Projects - LTC3020\Figures\TC3020\_Figure7.mxd\*caroline.souday\*29/01/2021



Contains Ordnance Survey data © Crown copyright and database right 2020, provided by client

Figure 7: Detailed plan of Trenches 141-5

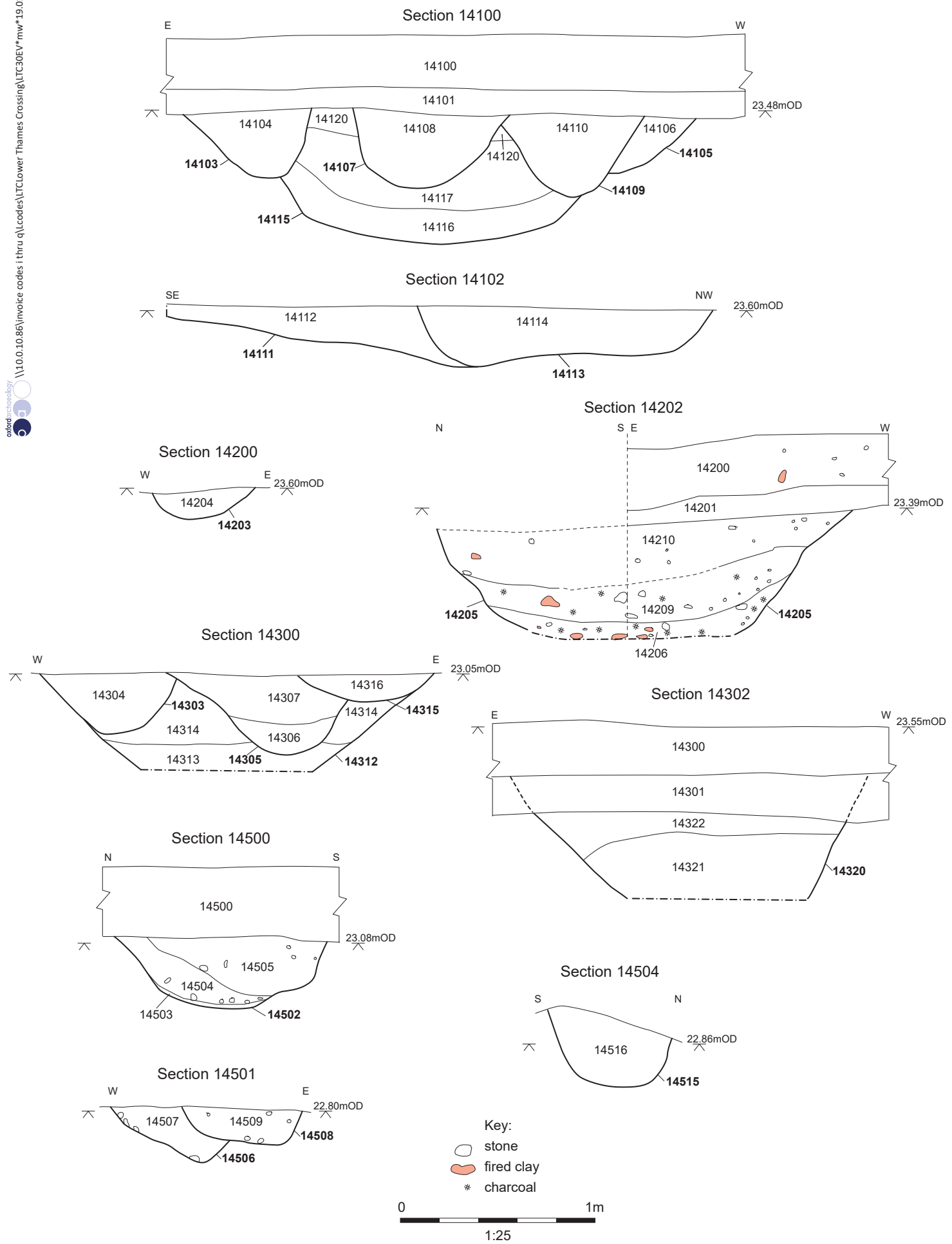
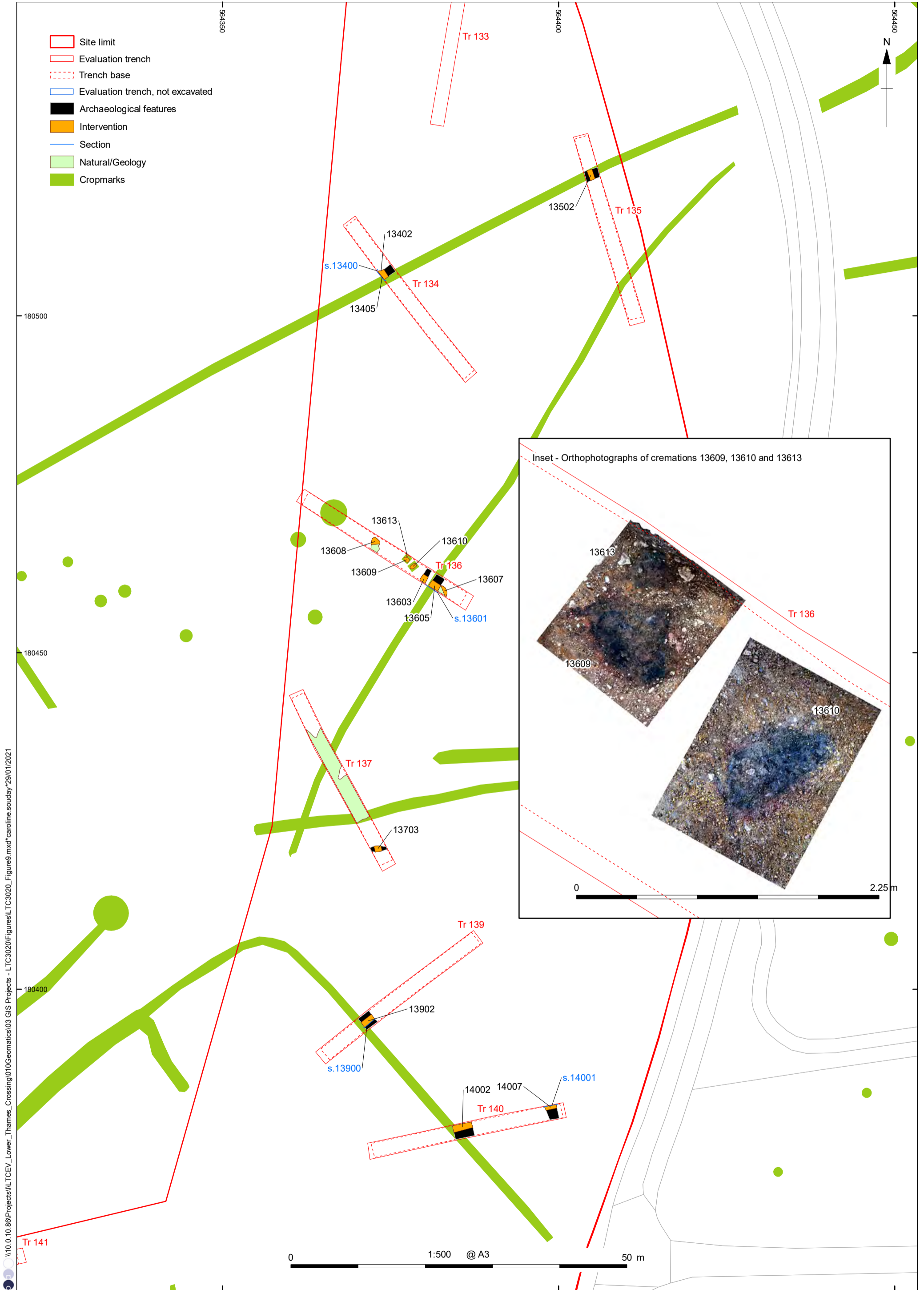

Figure 8: Sections, Trenches 141-3 and 145  
 Document Number: HE540039-BAL-GEN-GEN-REP-HER-00032 Page 201 of 245  
 Rev: P01



\\10.0.10.86\Projects\ILTCEV\_Lower\_Thames\_Crossing\010\Geomatics\03 GIS Projects - LTC3020\Figures\LTC3020\_Figure9.mxd\*caroline.souday\*29/01/2021

Contains Ordnance Survey data © Crown copyright and database right 2020, provided by client

Figure 9: Detailed plan of Trenches 134-7, 139 and 140

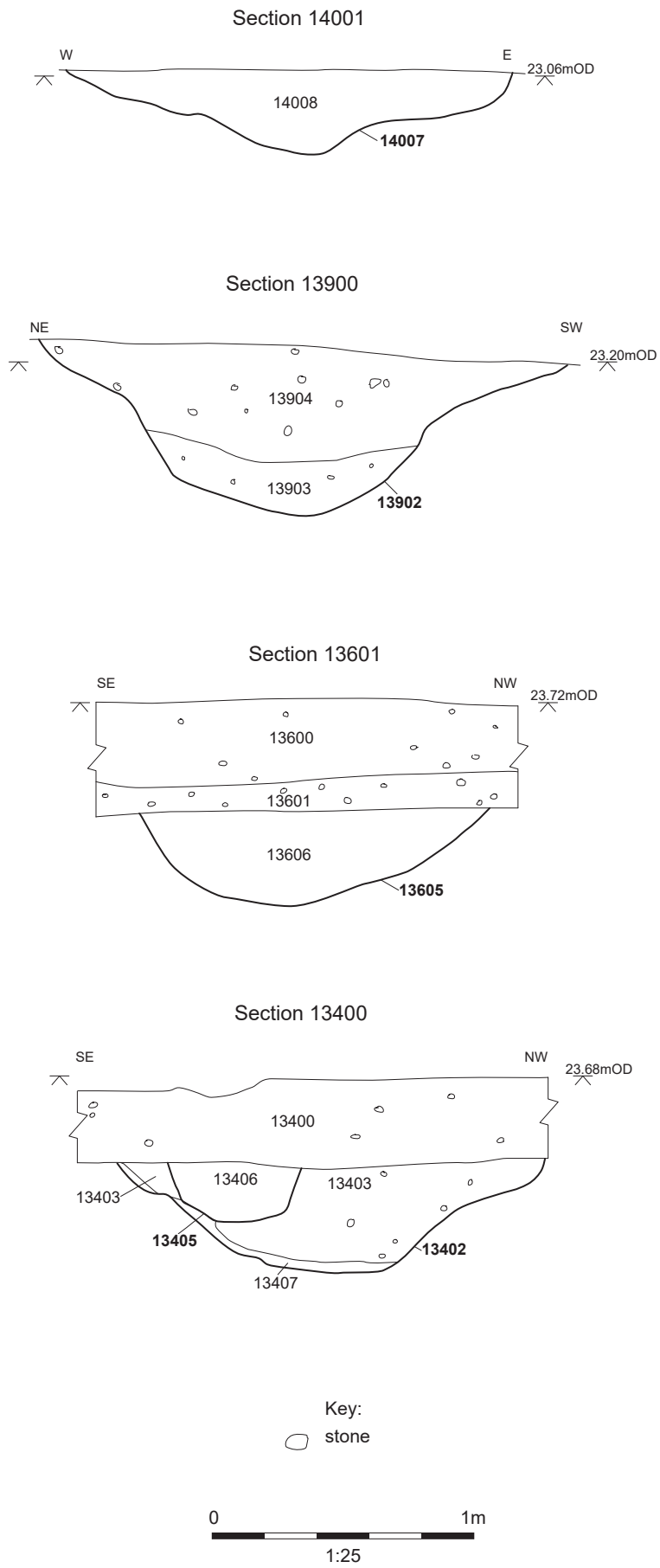
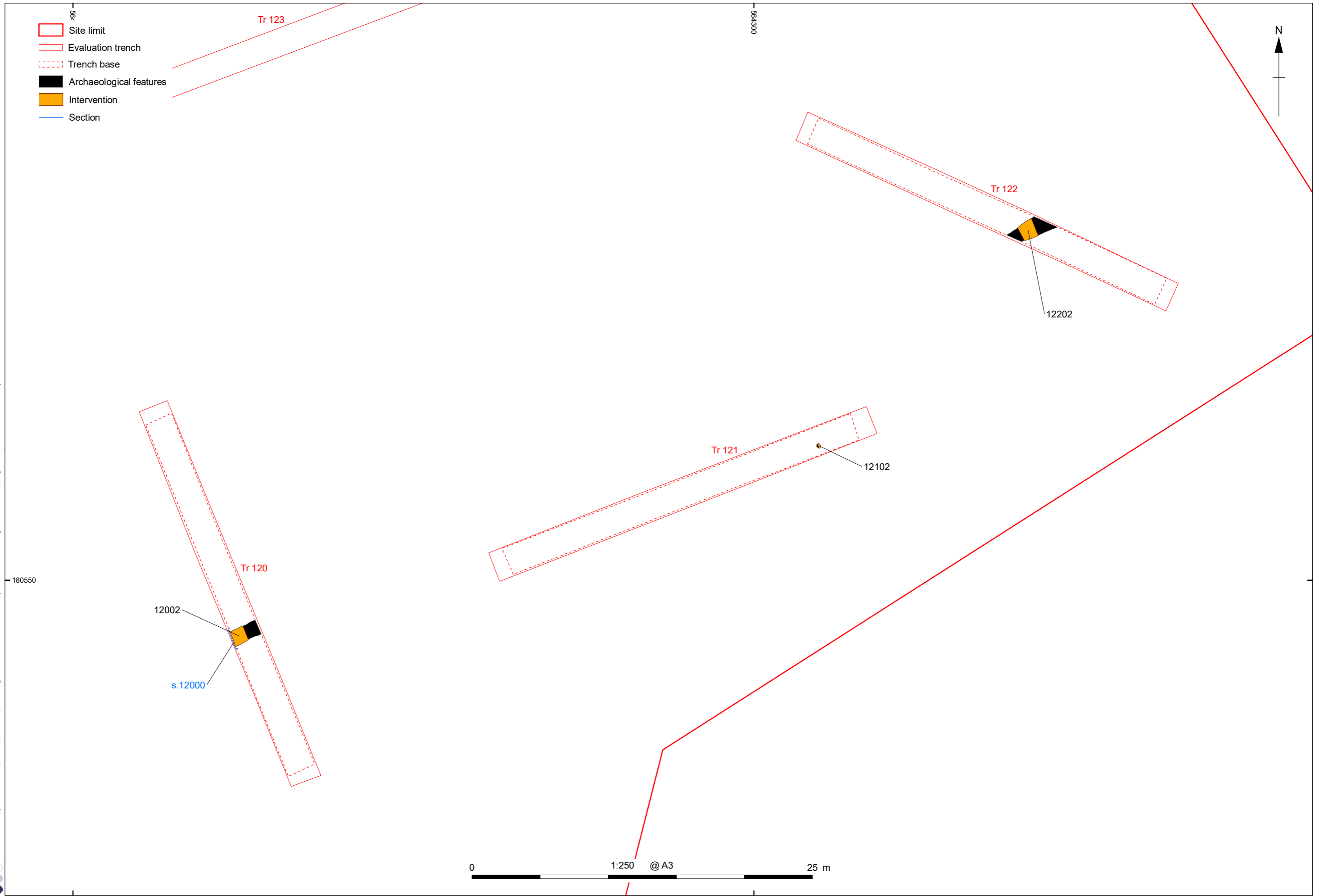

Figure 10: Sections, Trenches 134, 136, 139 and 140

\\10.0.10.86\Projects\TCEV\_Lower\_Thames\_Crossing\010\geomatics\03 GIS Projects - LTC3020\Figures\TC3020\_Figure11.mxd\*caroline.souday\*29/01/2021



Contains Ordnance Survey data © Crown copyright and database right 2020, provided by client

Figure 11: Detailed plan of Trenches 120-2



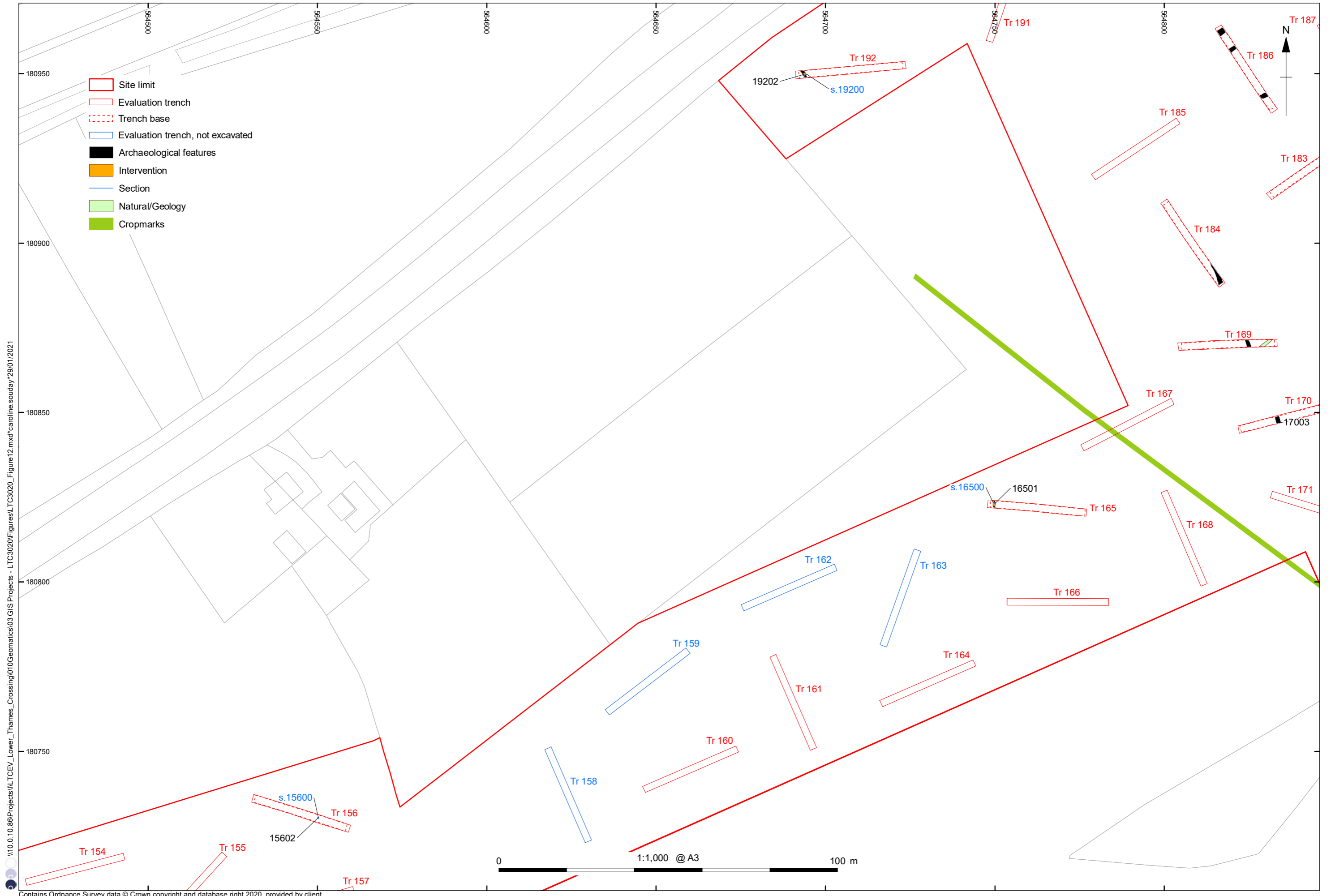

\\10.0.10.86\Projects\IL TCEV\_Lower\_Themes\_Crossing\01\0\geomatics\03 GIS Projects - LTC3020\Figures\TC3020\_Figure12.mxd\*caroline.souday\*29/01/2021

Contains Ordnance Survey data © Crown copyright and database right 2020, provided by client

Figure 12: Detailed plan of Trenches 156, 165 and 192

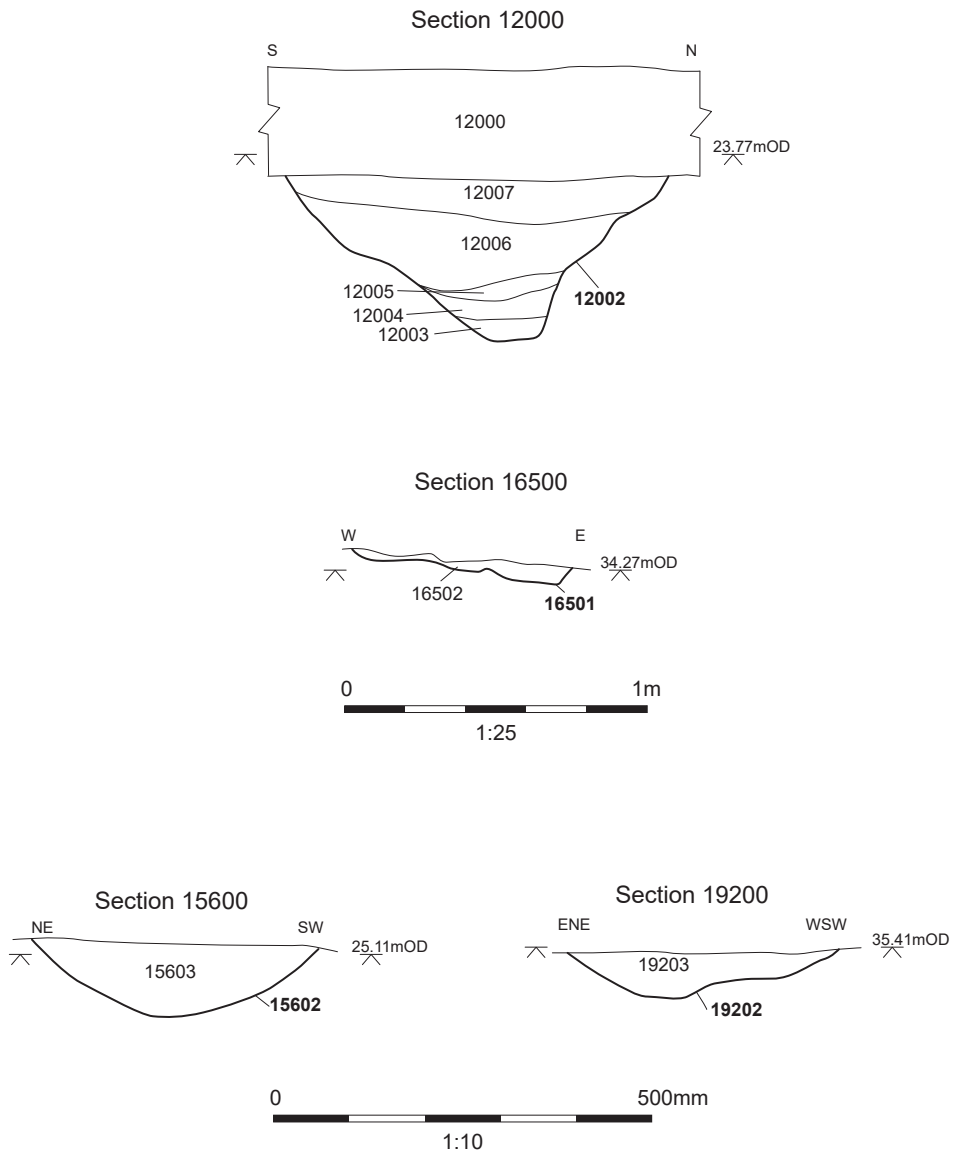
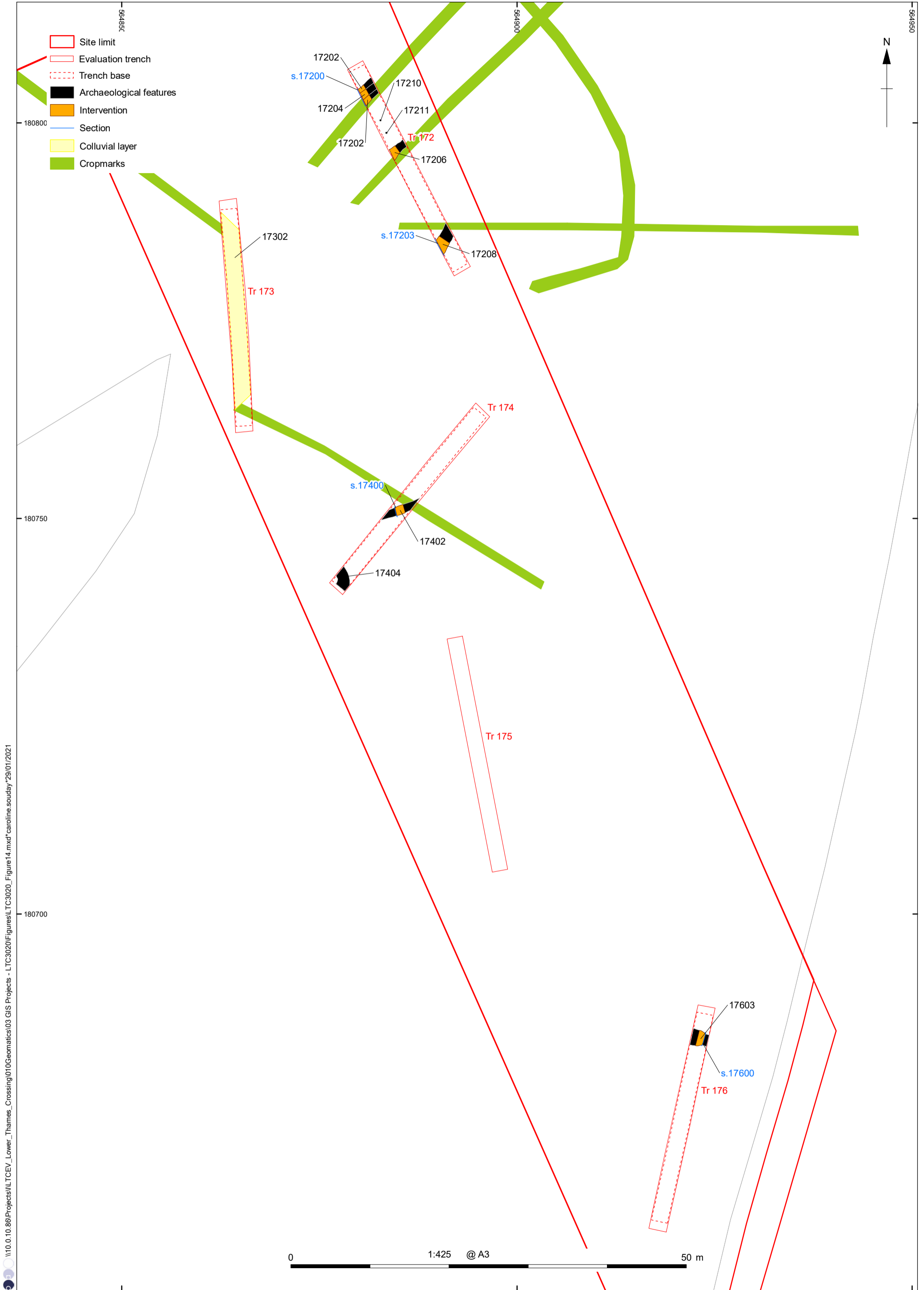

Figure 13: Sections, Trenches 120, 156, 165 and 192  
Document Number: HE540039-BAL-GEN-GEN-REP-HER-00032 Page 206 of 245  
Rev: P01



\\10.0.10.86\Projects\10.86\Projects\Lower\_Thames\_Crossing\10\Geomatics\03 GIS Projects - LTC3020\Figures\LTC3020\_Figure14.mxd\*caroline.souday\*29/01/2021

Contains Ordnance Survey data © Crown copyright and database right 2020, provided by client

Figure 14: Detailed plan of Trenches 172-4 and 176

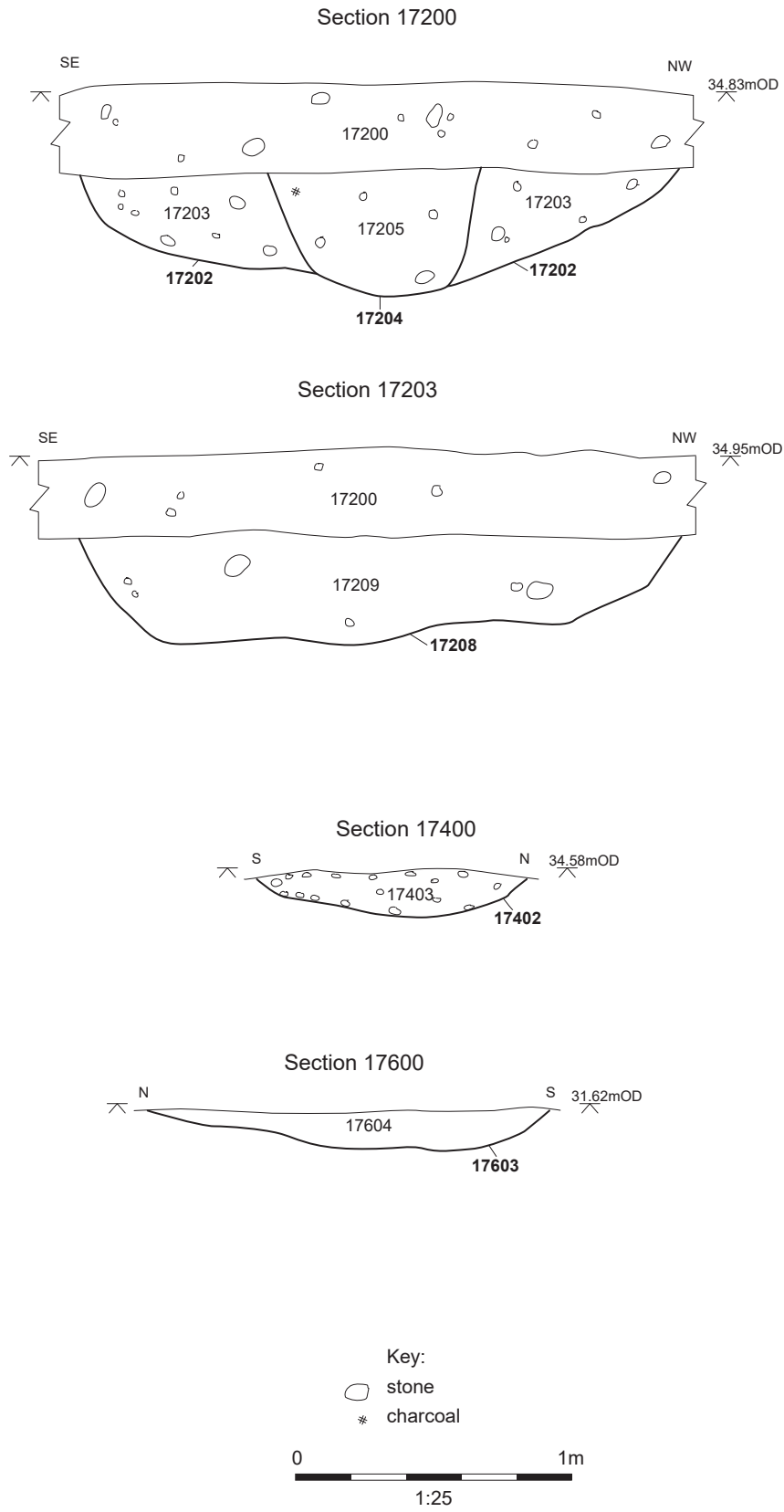
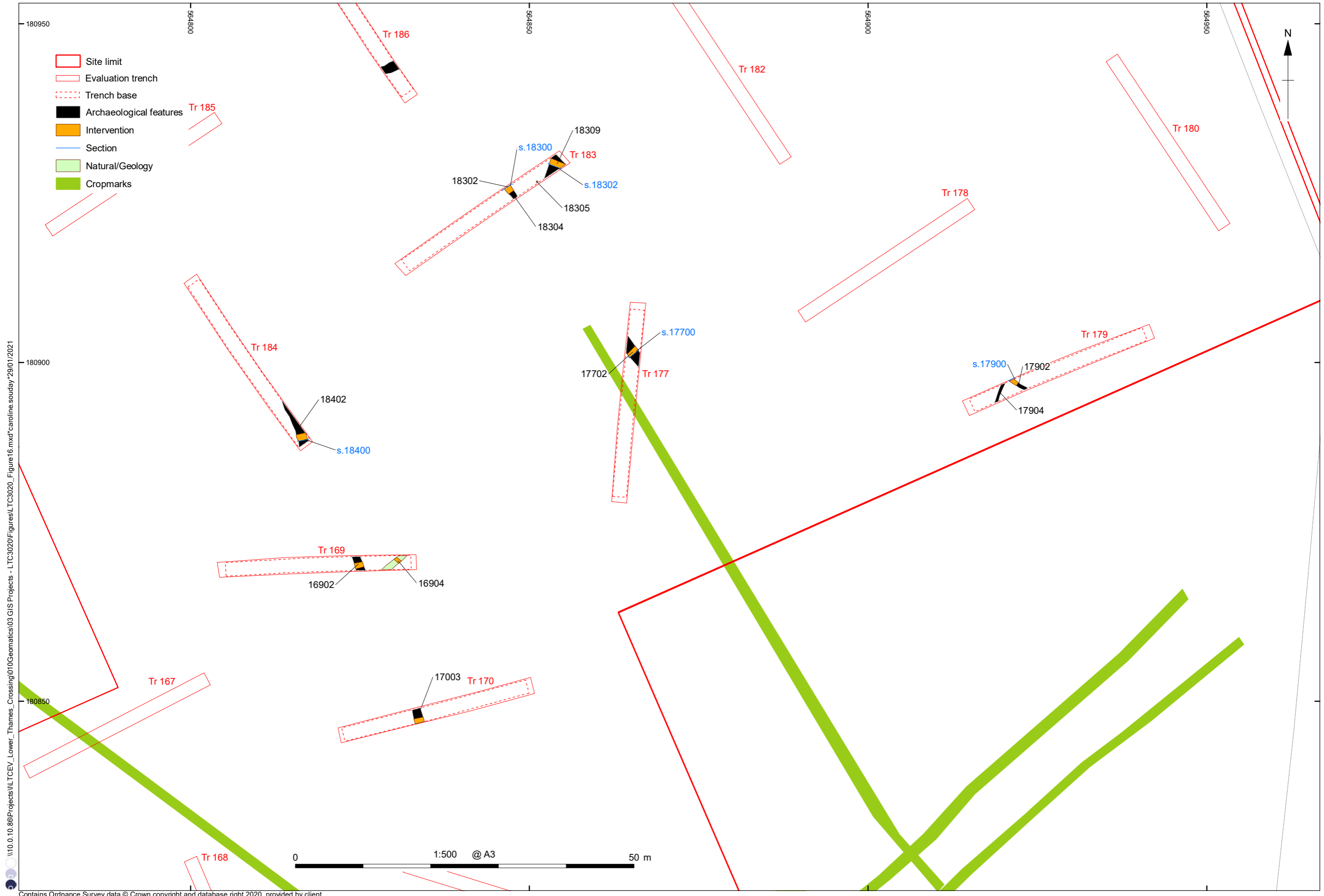

Figure 15: Sections, Trenches 172, 174 and 176  
Document Number: HE540039-BAL-GEN-GEN-REP-HER-00032 Page 208 of 245  
Rev: P01



\\10.0.10.86\Projects\10.86\Projects\010\Geomatics\03 GIS Projects - L TC3020\Figures\TC3020\_Figure16.mxd\caroline.souday\*29/01/2021

Contains Ordnance Survey data © Crown copyright and database right 2020, provided by client

Figure 16: Detailed plan of Trenches 169, 170, 177, 179 and 183-4

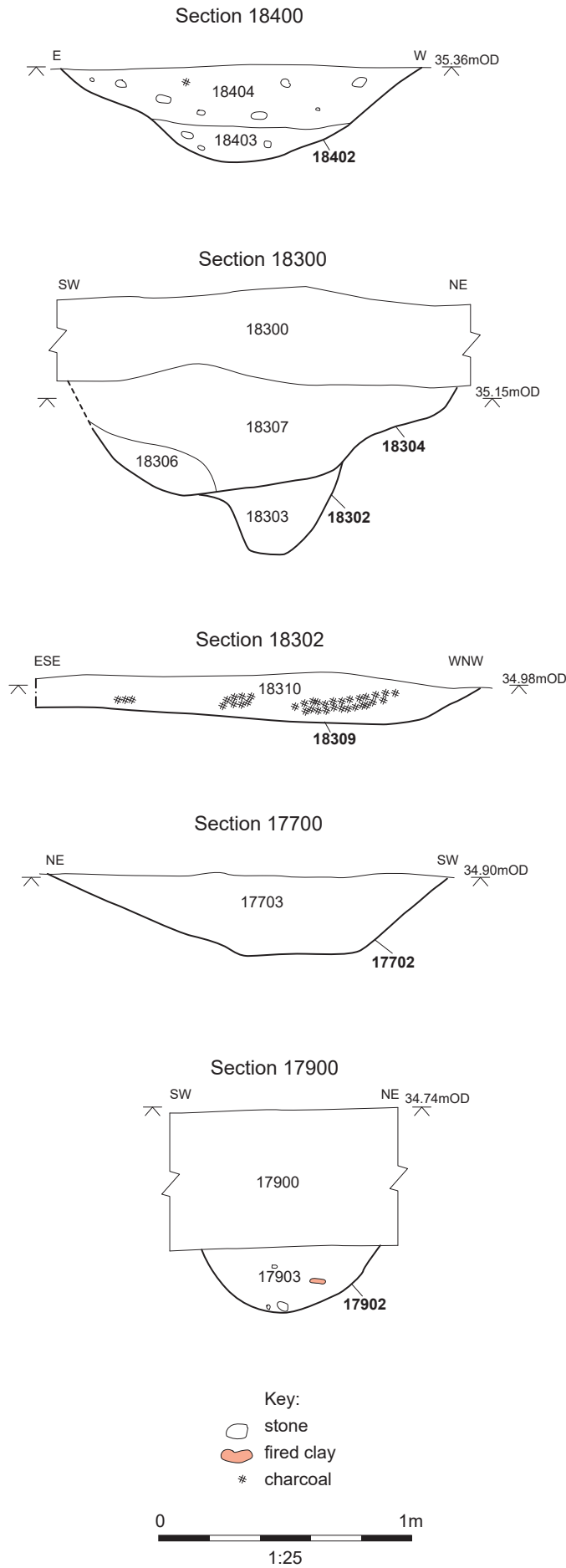
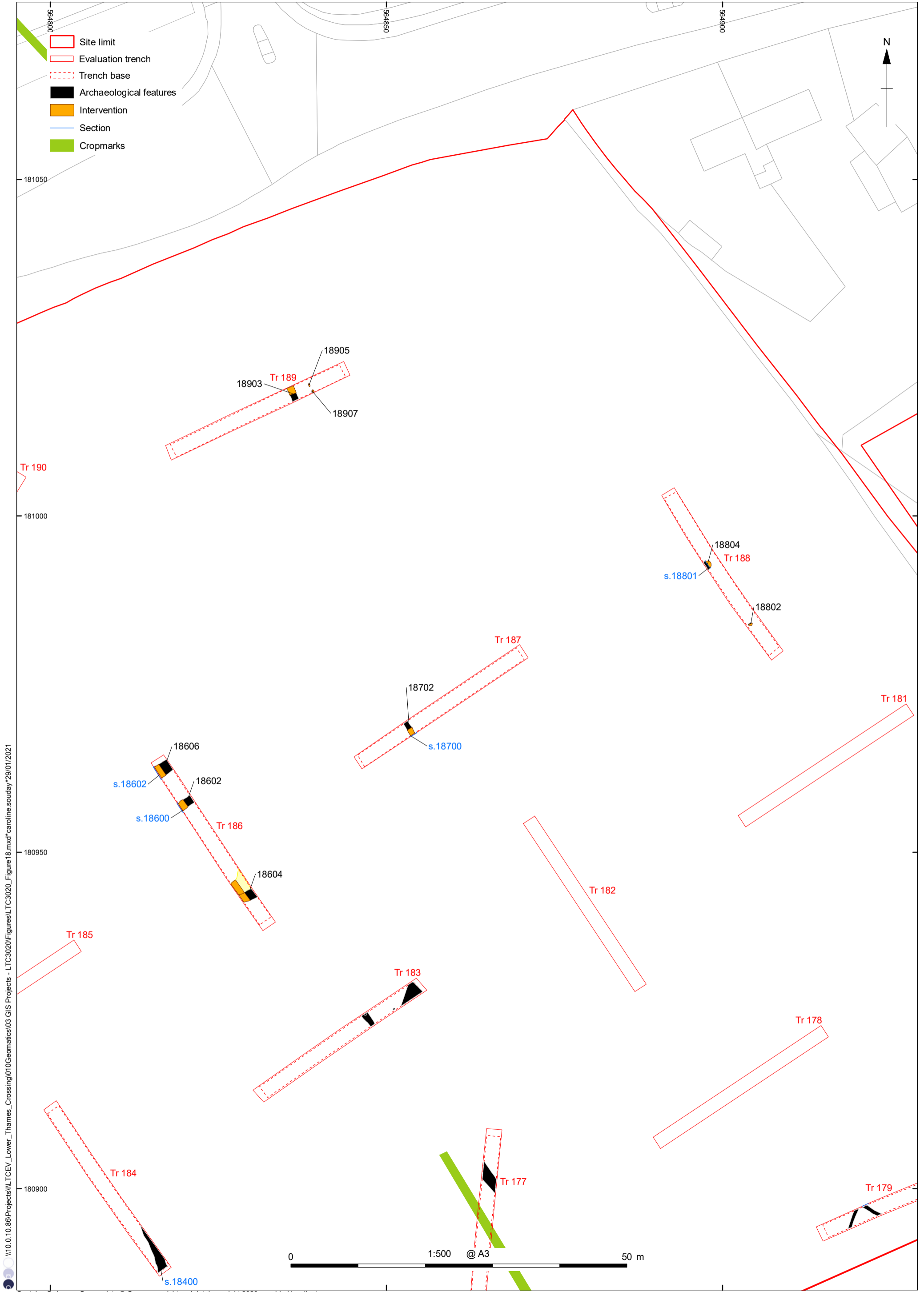

Figure 17: Sections, Trenches 177, 179 and 183-4  
Document Number: HE540039-BAL-GEN-GEN-REP-HER-00032 Page 210 of 245  
Rev: P01



\\10.0.10.86\Projects\ILTCEV\_Lower\_Thames\_Crossing\010\Geomatics\03 GIS Projects - LTC3020\Figures\LTC3020\_Figure18.mxd\*caroline.souday\*29/01/2021

Contains Ordnance Survey data © Crown copyright and database right 2020, provided by client

Figure 18: Detailed plan of Trenches 186-9

Section 18600

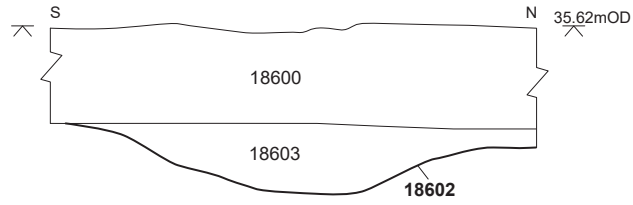

Section 18602

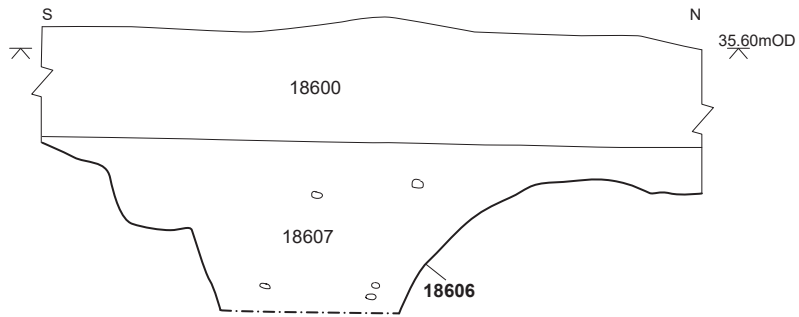

Section 18700

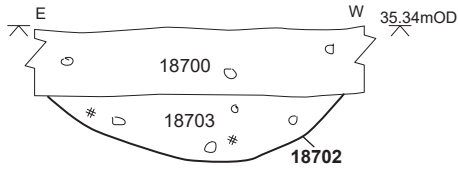

Section 18801

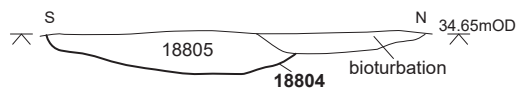

Key:

- stone
- \* charcoal

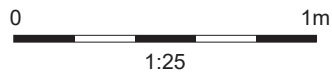
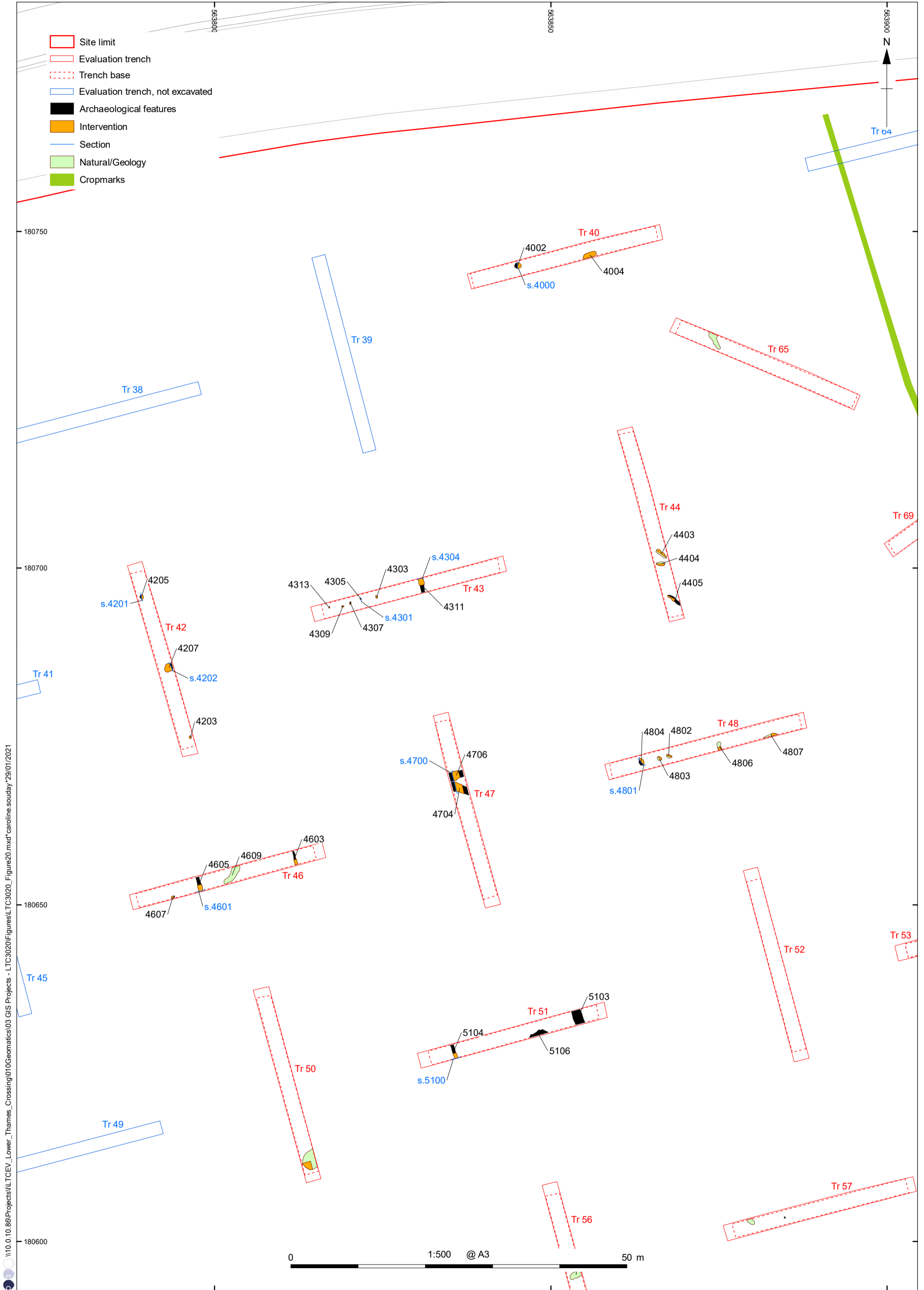

Figure 19: Sections, Trenches 186-8





\\10.0.10.86\Projects\10\TCEV\_Lower\_Thames\_Crossing\010\Geomatics\03 GIS Projects - LTC3020\Figures\LTC3020\_Figure20.mxd\*caroline.souday\*29/01/2021

Contains Ordnance Survey data © Crown copyright and database right 2020, provided by client

Figure 20: Detailed plan of Trenches 40, 42-4, 46-8 and 51

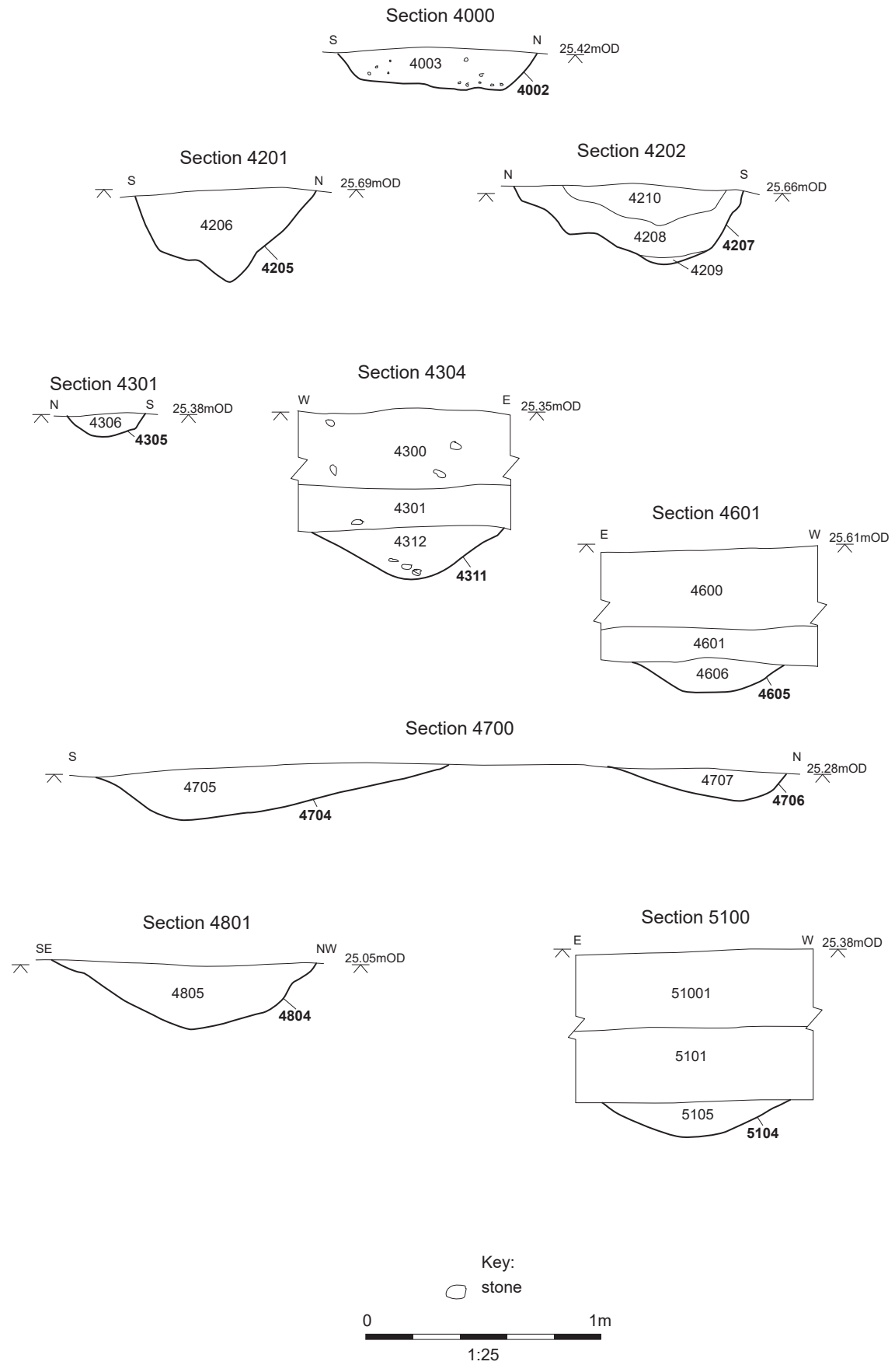
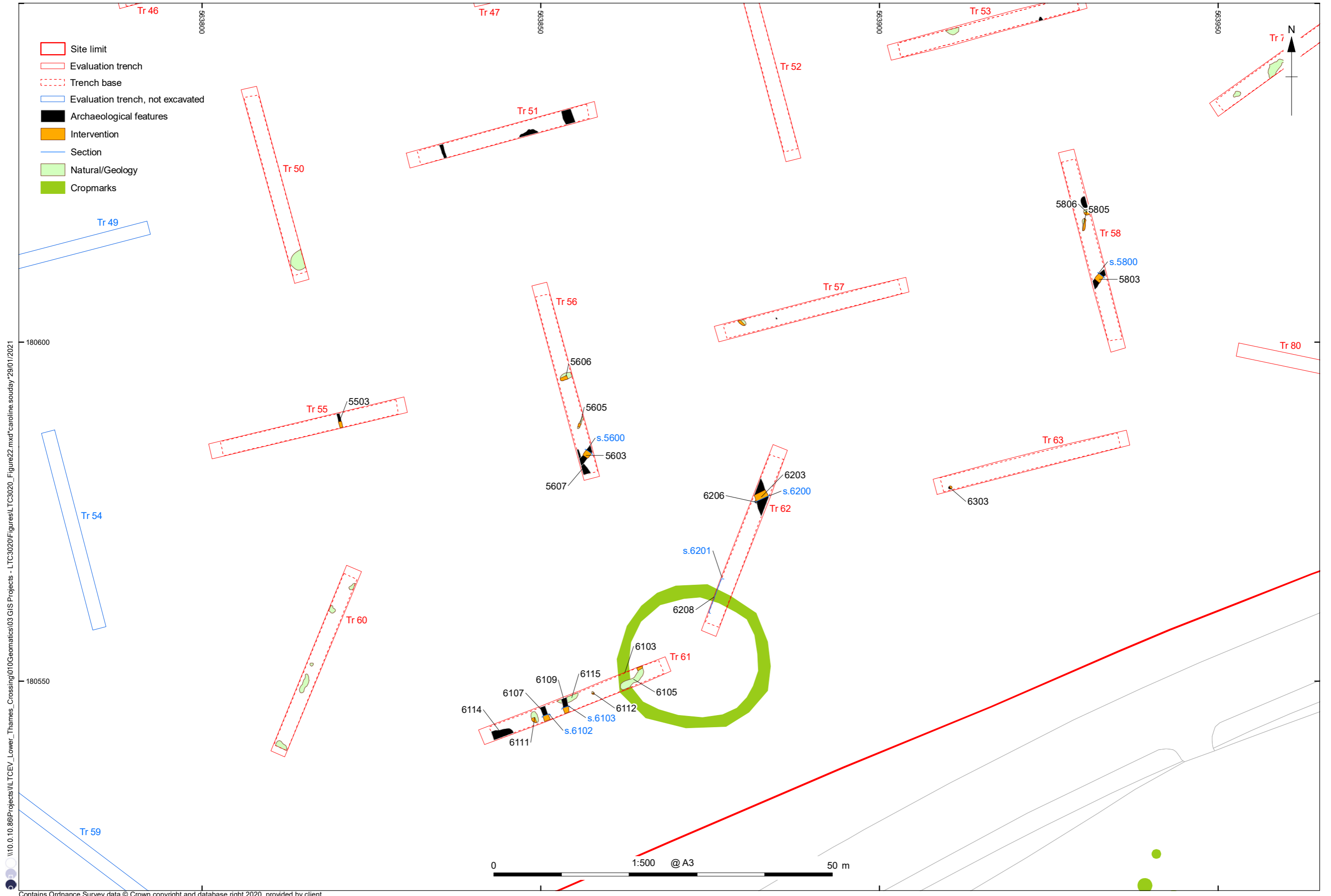

Figure 21: Sections, Trenches 40, 42-3, 46-8 and 51  
Document Number: HE540039-BAL-GEN-GEN-REP-HER-00032 Page 214 of 245  
Rev: P01



\\10.0.10.86\Projects\IL TCEV\_Lower\_Thames\_Crossing\010\geomatics\03 GIS Projects - LTC3020\Figures\TC3020\_Figure22.mxd\*caroline.souday\*29/01/2021

Contains Ordnance Survey data © Crown copyright and database right 2020, provided by client

Figure 22: Detailed plan of Trenches 56, 58, and 61-2

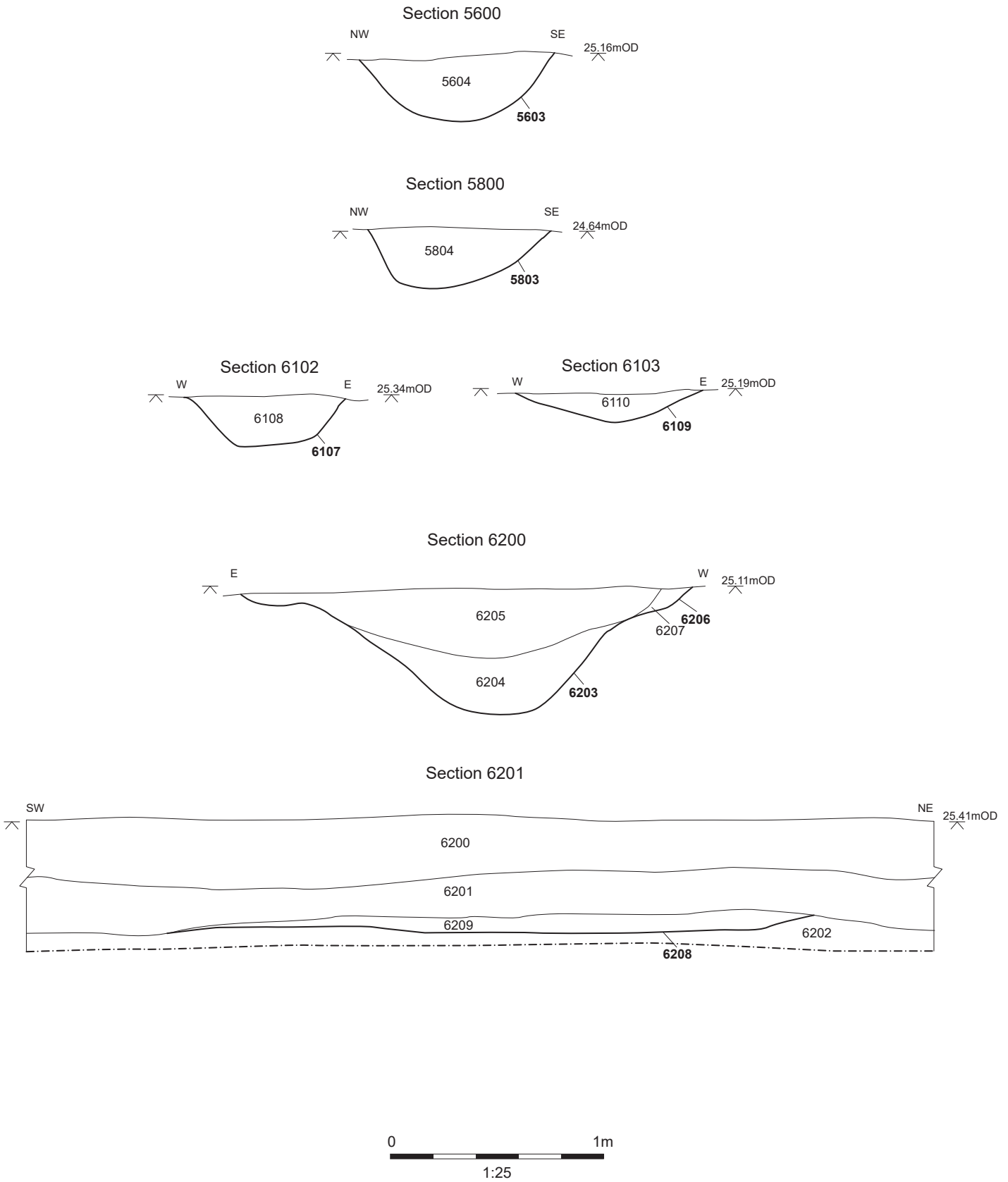
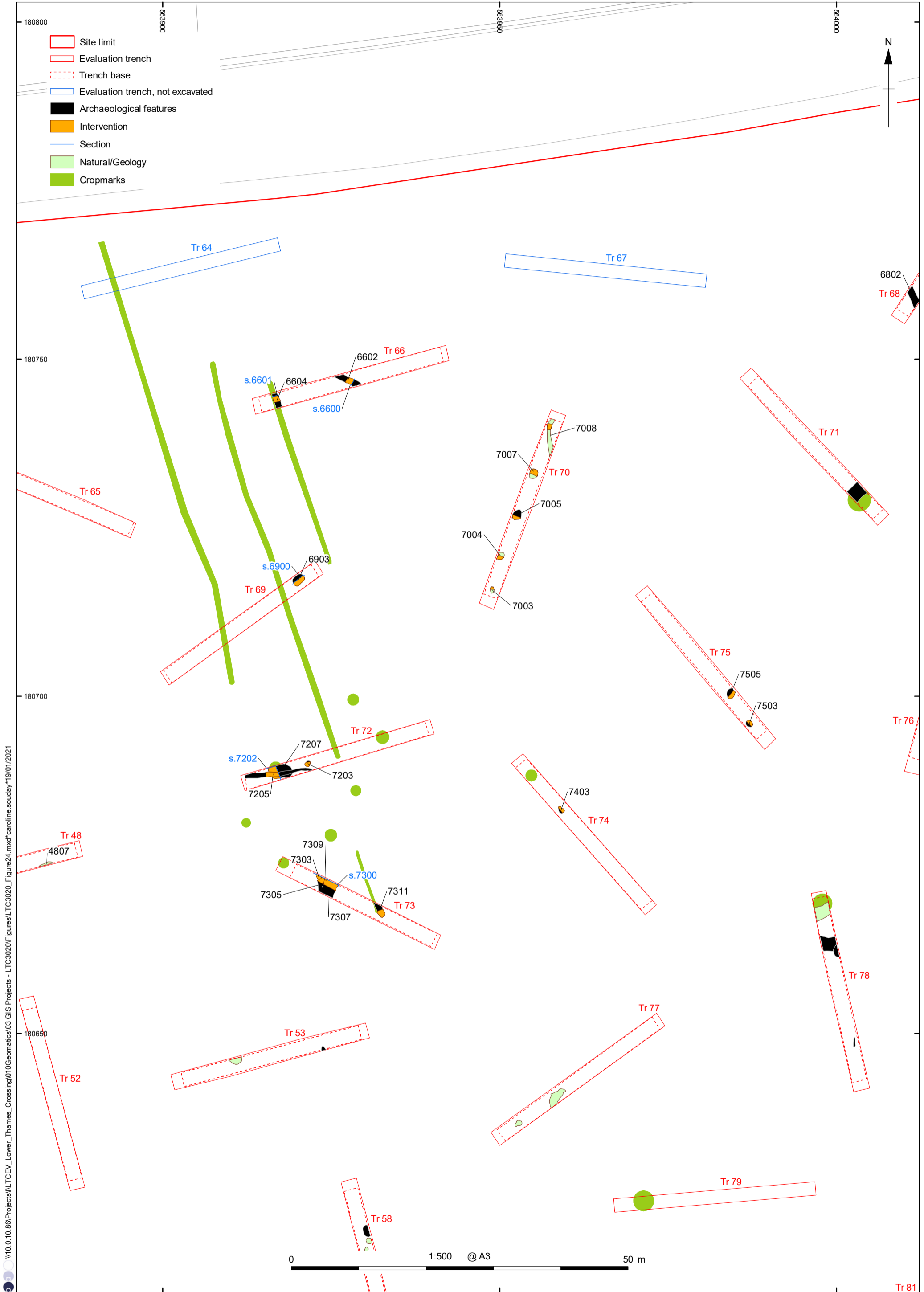

Figure 23: Sections, Trenches 56, 58, 61 and 62  
Document Number: HE540039-BAL-GEN-GEN-REP-HER-00032 Page 216 of 245  
Rev: P01



\\10.0.10.86\Projects\Lower\_Thames\_Crossing\010\Geomatics\03 GIS Projects - LTC3020\Figures\LTC3020\_Figure24.mxd\*caroline.souday\*19/01/2021

Contains Ordnance Survey data © Crown copyright and database right 2020, provided by client

Figure 24: Detailed plan of Trenches 66, 69, 70 and 72-5

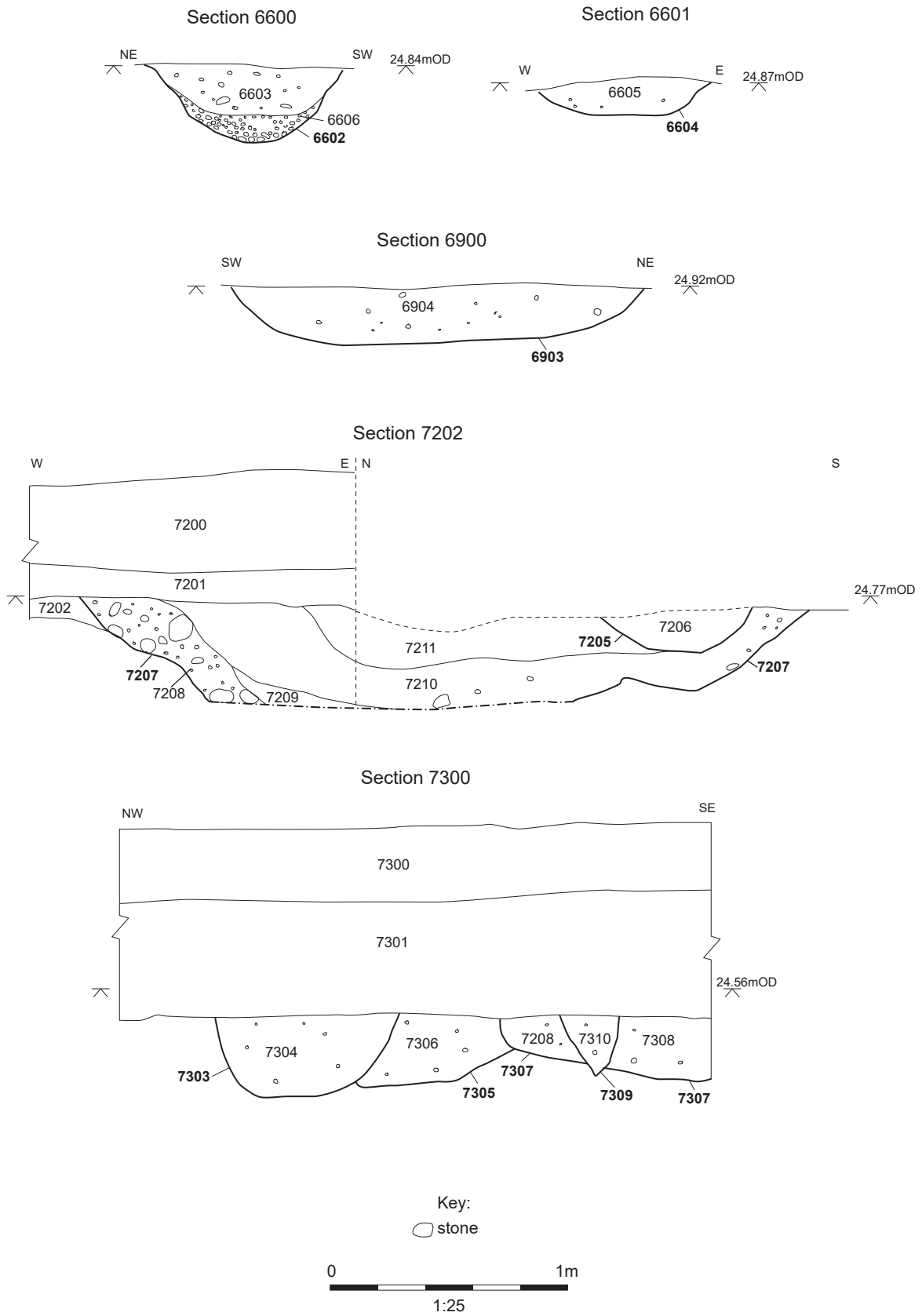

Figure 25: Sections, Trenches 66, 69, 72 and 73  
Document Number: HE540039-BAL-GEN-GEN-REP-HER-00032 Page 218 of 245  
Rev: P01

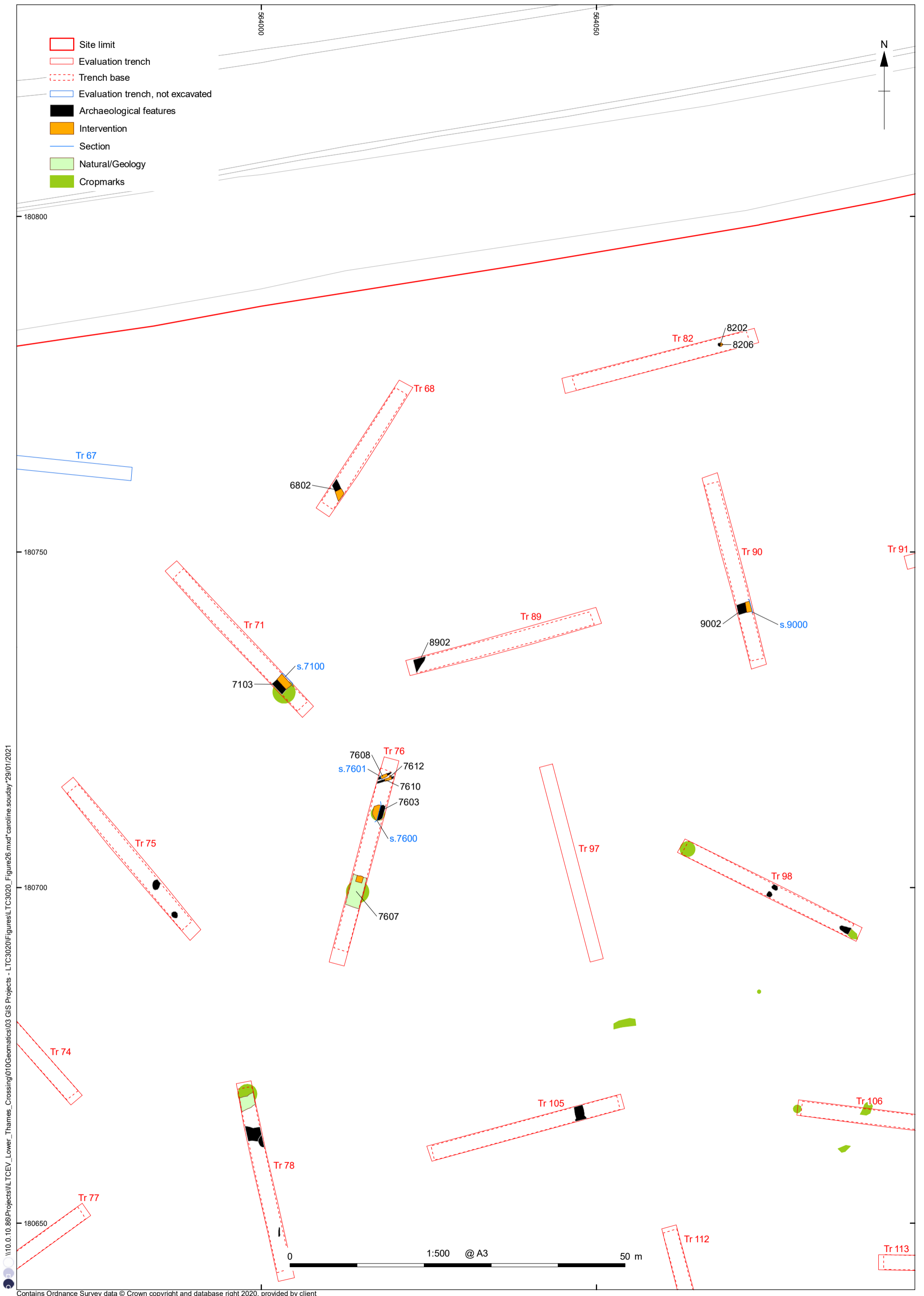

Figure 26: Detailed plan of Trenches 68, 71, 76, 82, 89, and 90

\\10.0.10.86\Projects\Lower\_Thames\_Crossing\010\Geomatics\03 GIS Projects - LTC3020\Figures\LTC3020\_Figure26.mxd\*caroline.souday\*29/01/2021

Contains Ordnance Survey data © Crown copyright and database right 2020, provided by client

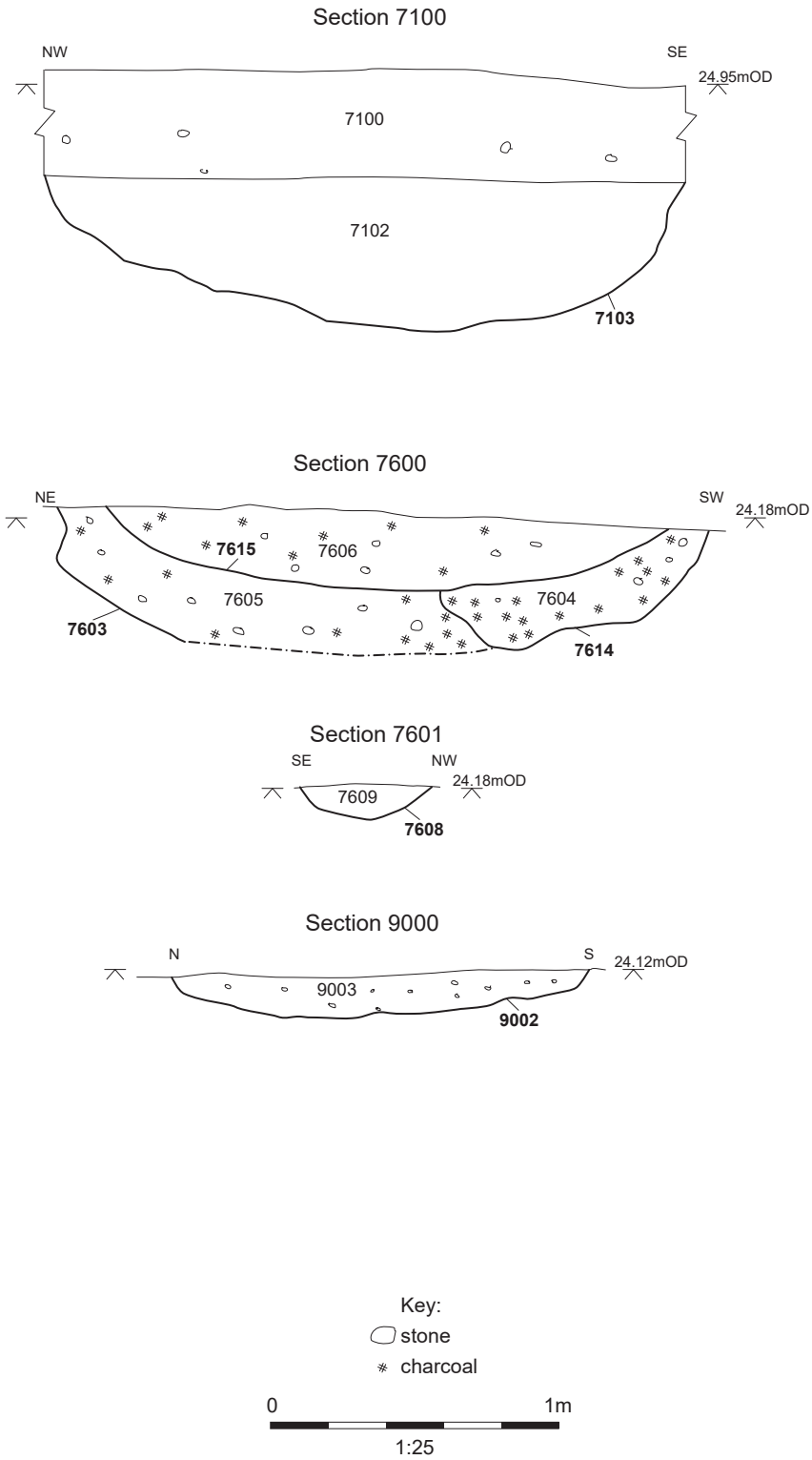
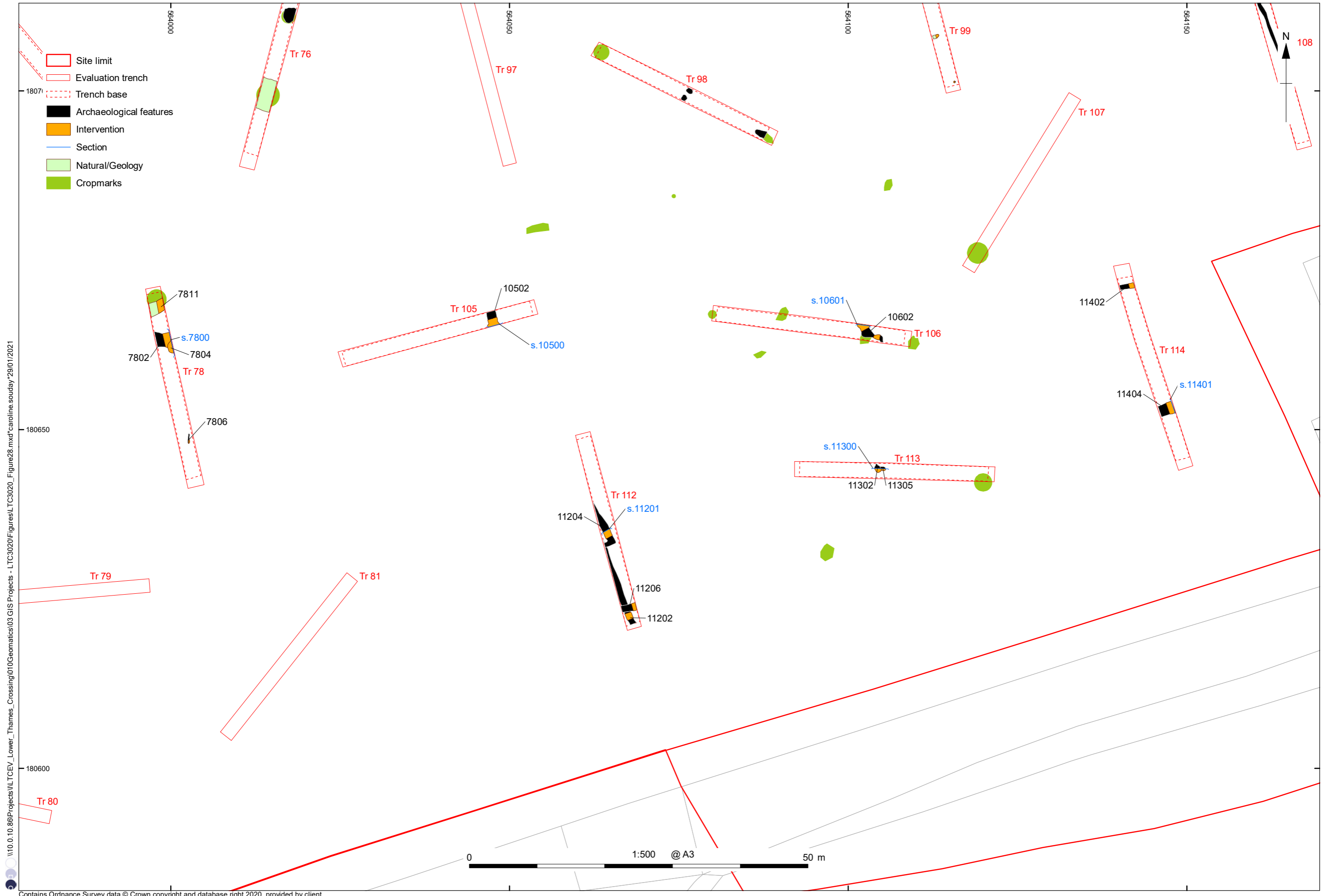

Figure 27: Sections, Trenches 71, 76 and 90





\\10.0.10.86\Projects\IL TCEV\_Lower\_Thames\_Crossing\010\geomatics\03 GIS Projects - LTC3020\Figures\TC3020\_Figure28.mxd\*caroline.souday\*29/01/2021

Contains Ordnance Survey data © Crown copyright and database right 2020, provided by client

Figure 28: Detailed plan of Trenches 78, 105-6 and 112-14

### Section 7800

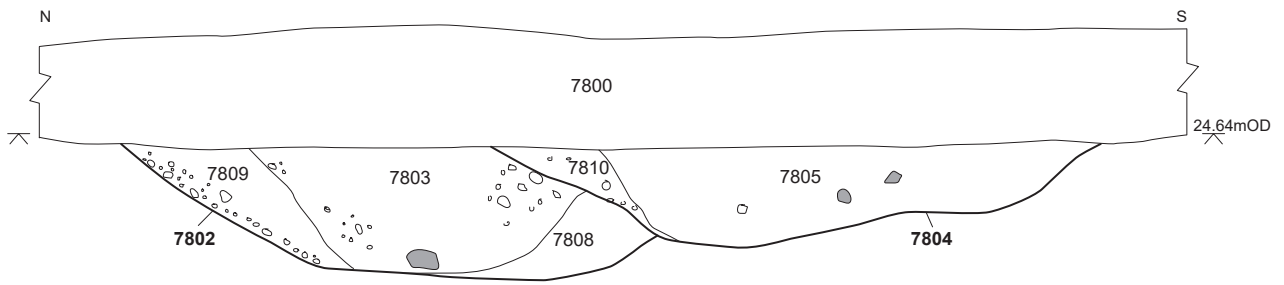

### Section 10500

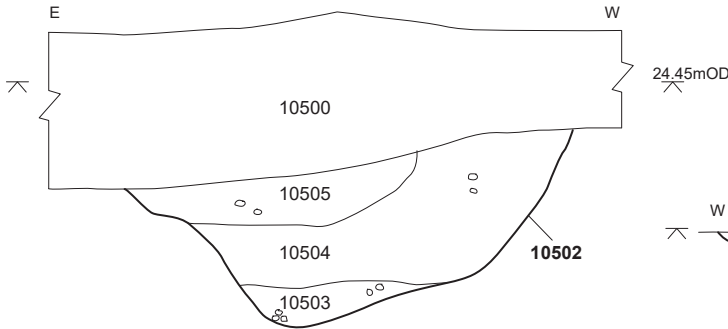

### Section 11201

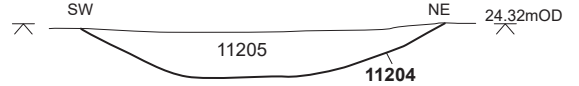

### Section 11300

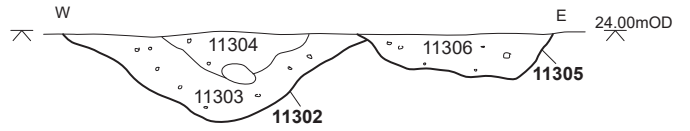

### Section 10601

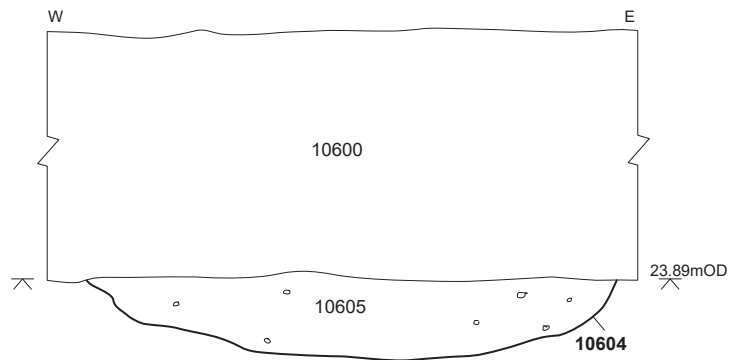

### Section 11401

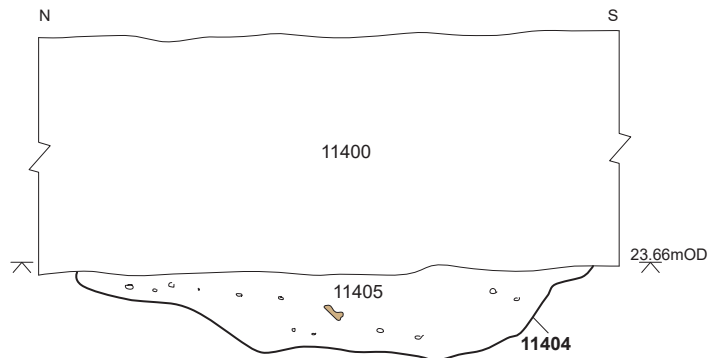

Key:

- stone
- \* charcoal
- ▭ bone
- flint



Figure 29: Sections, Trenches 78, 105-6 and 112-14

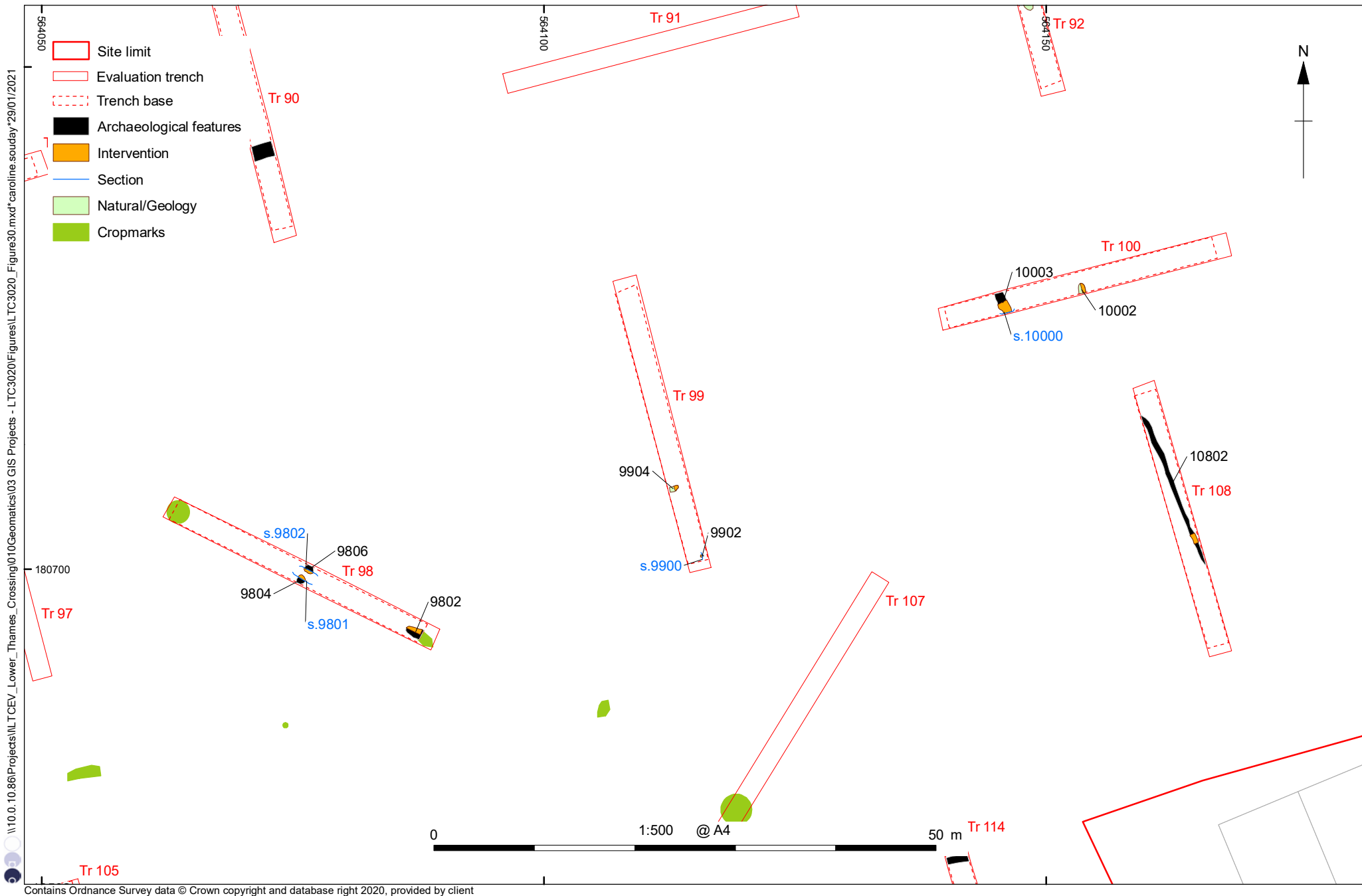

Figure 30: Detailed plan of Trenches 98-100 and 108

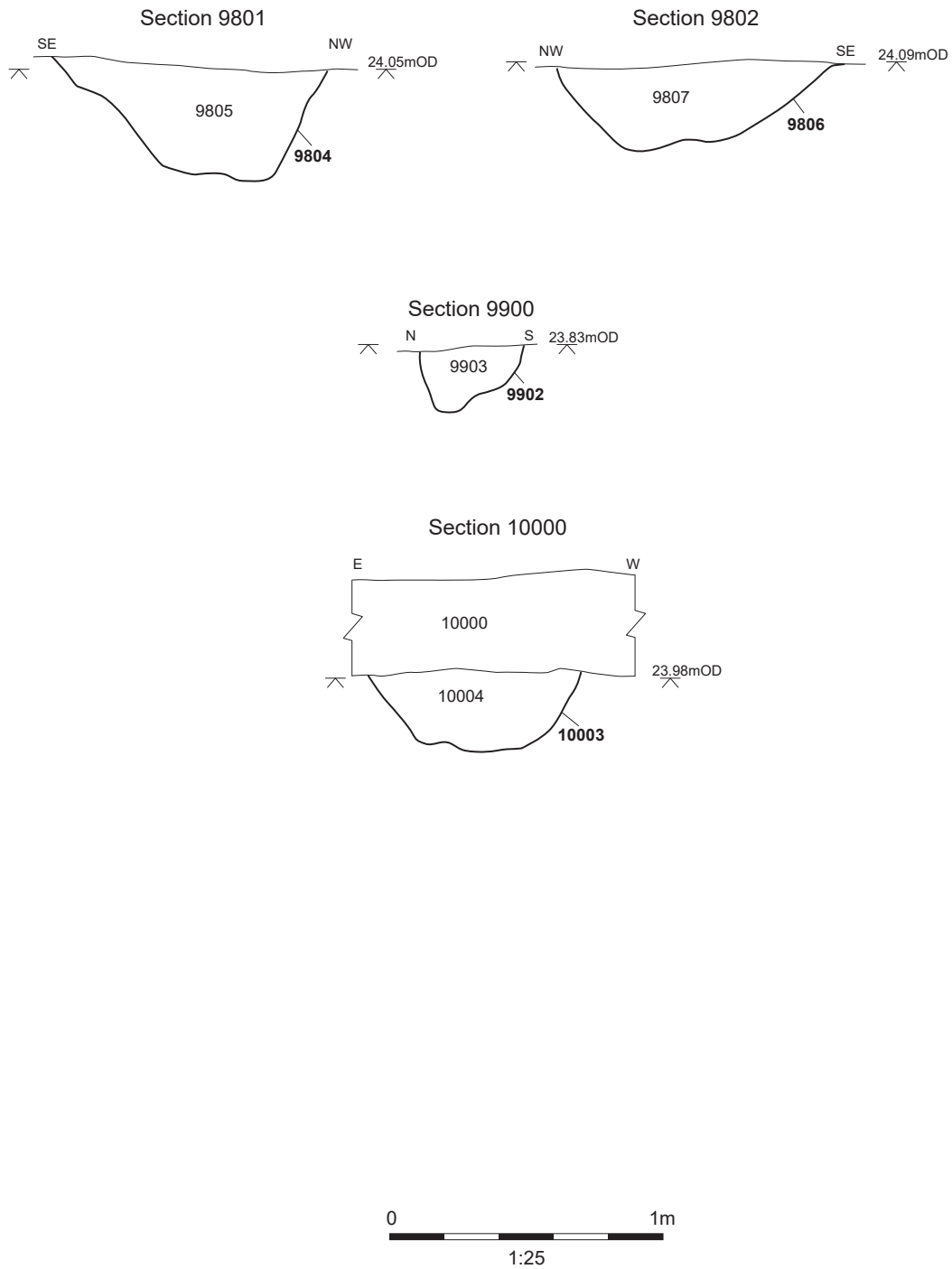
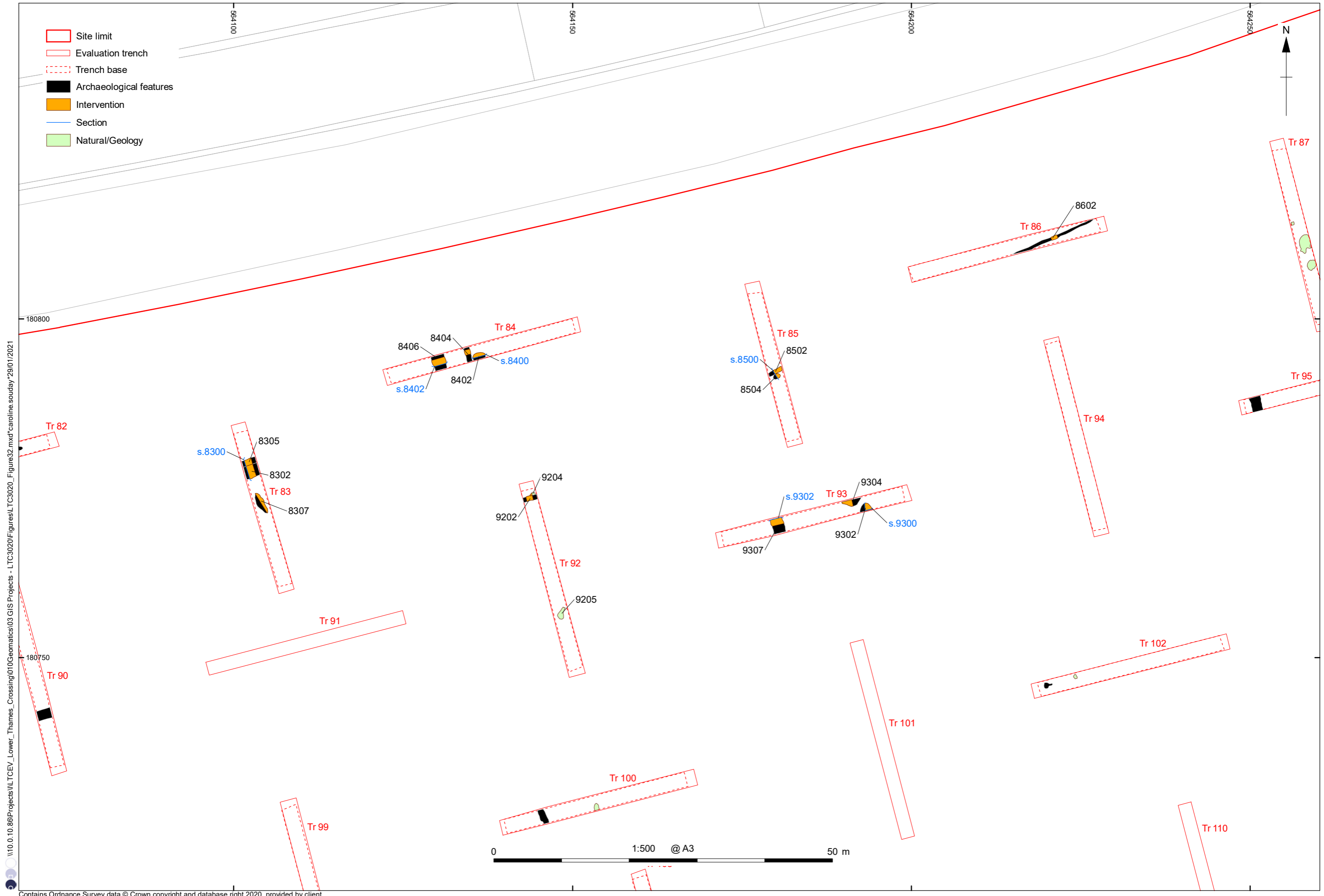

Figure 31: Sections, Trenches 98-100  
Document Number: HE540039-BAL-GEN-GEN-REP-HER-00032 Page 224 of 245  
Rev: P01



\\10.0.10.86\Projects\TCEV\_Lower\_Thames\_Crossing\010\ecometrics\03 GIS Projects - LTC3020\Figures\TC3020\_Figures32.mxd\*caroline.souday\*29/01/2021

Contains Ordnance Survey data © Crown copyright and database right 2020, provided by client

Figure 32: Detailed plan of Trenches 83-6 and 92-3

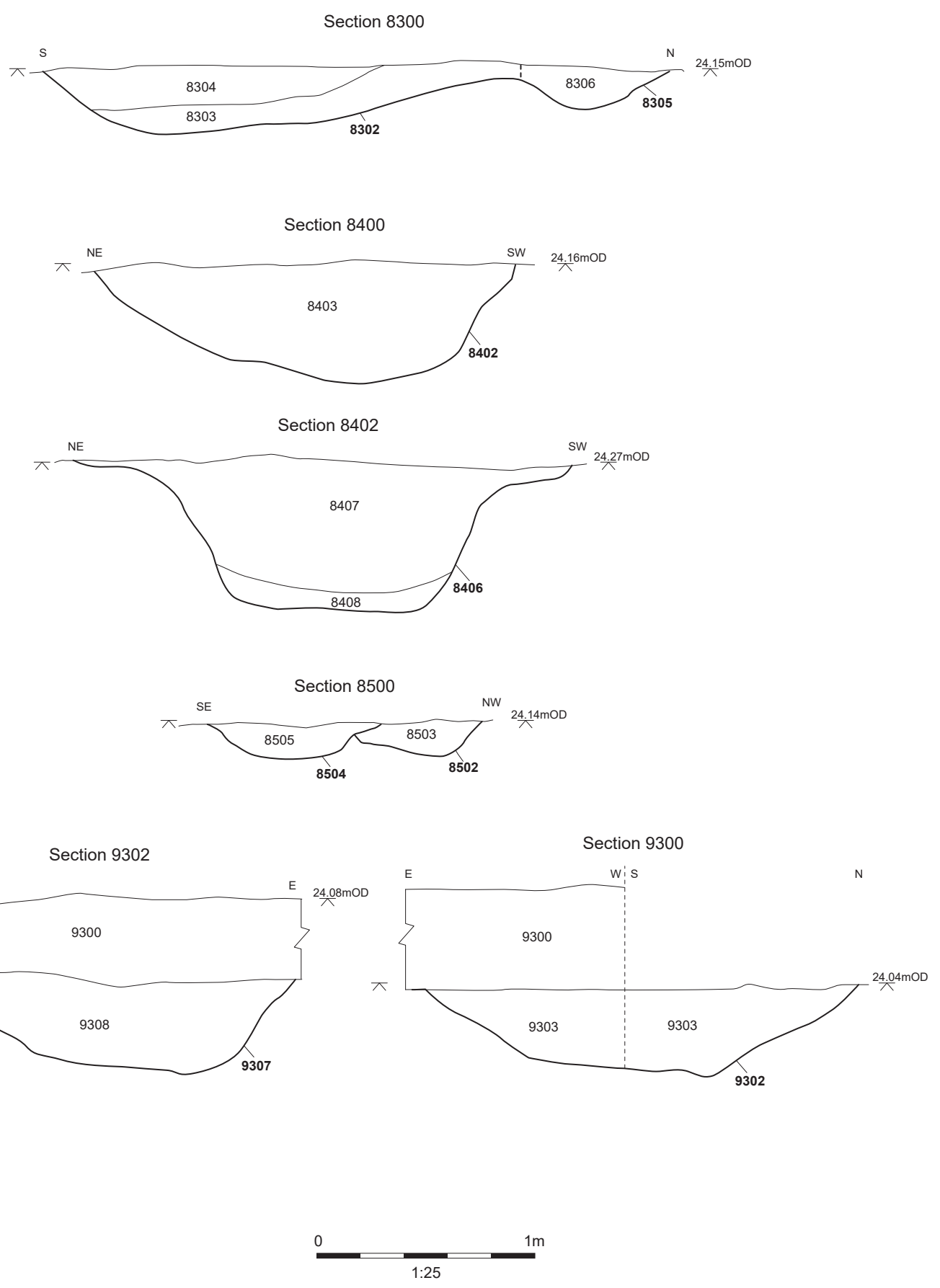

Figure 33: Sections, Trenches 83-5 and 93  
Document Number: HE540039-BAL-GEN-GEN-REP-HER-00032 Page 226 of 245  
Rev: P01

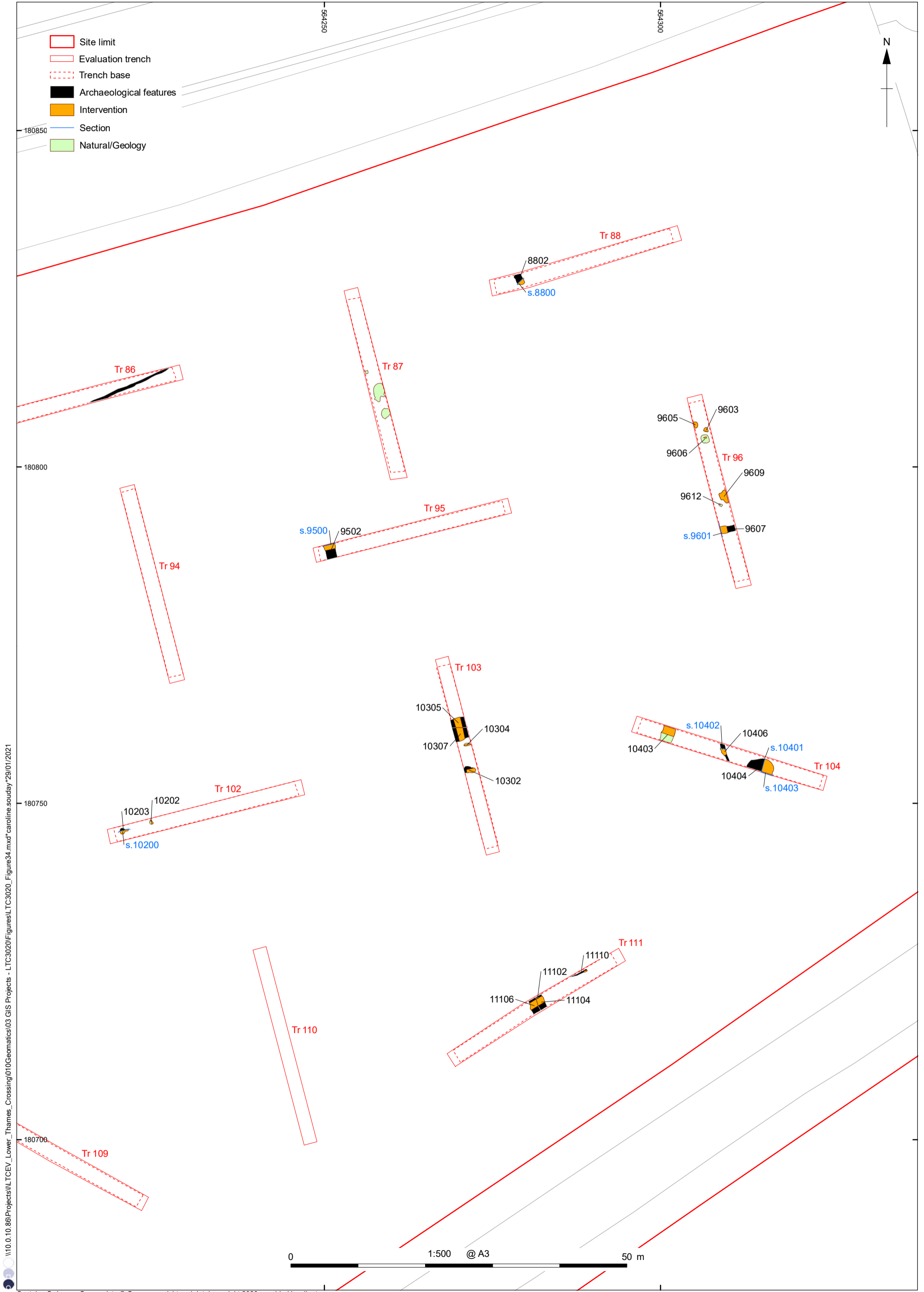

Figure 34: Detailed plan of Trenches 88, 95-6, 102-4 and 111

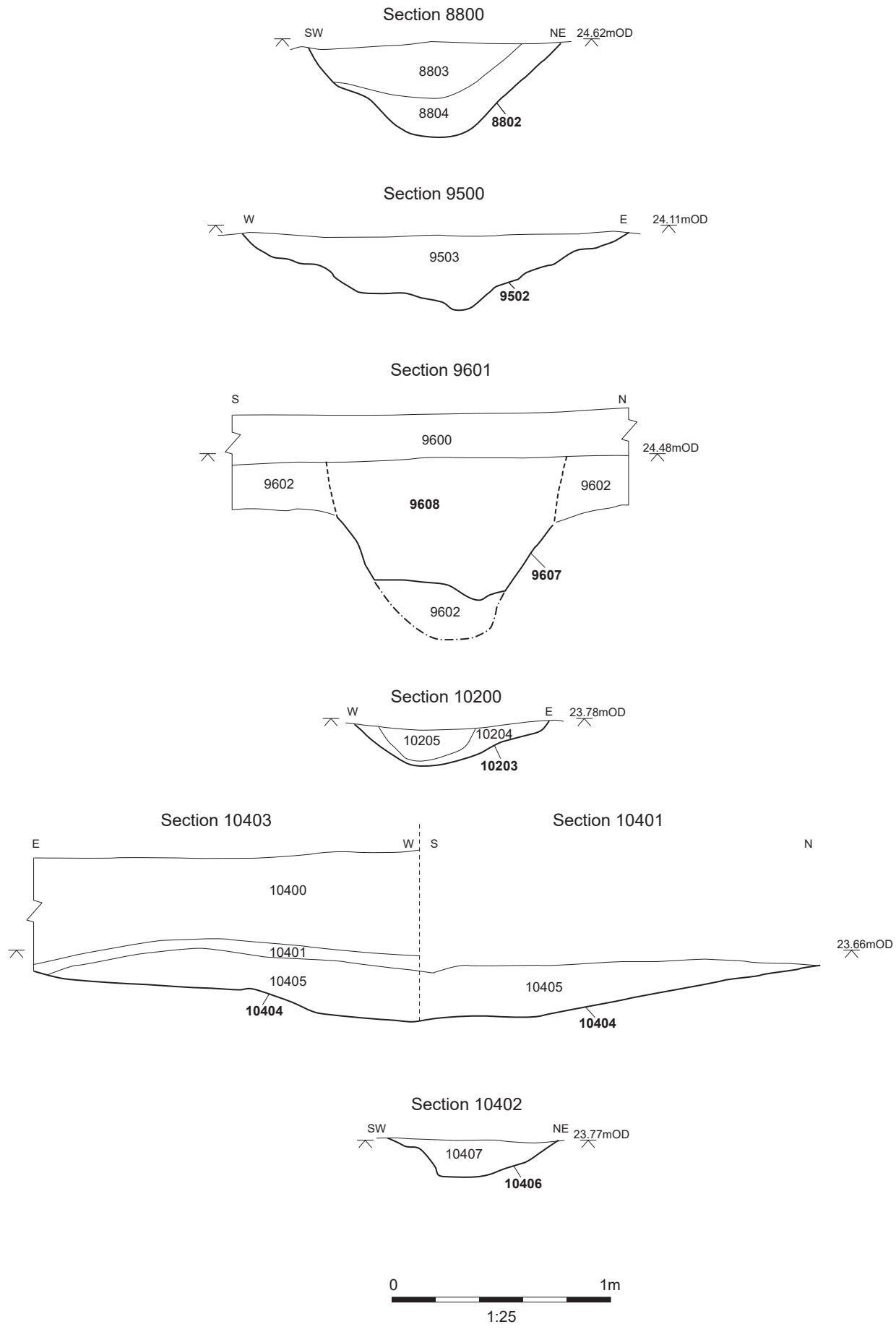
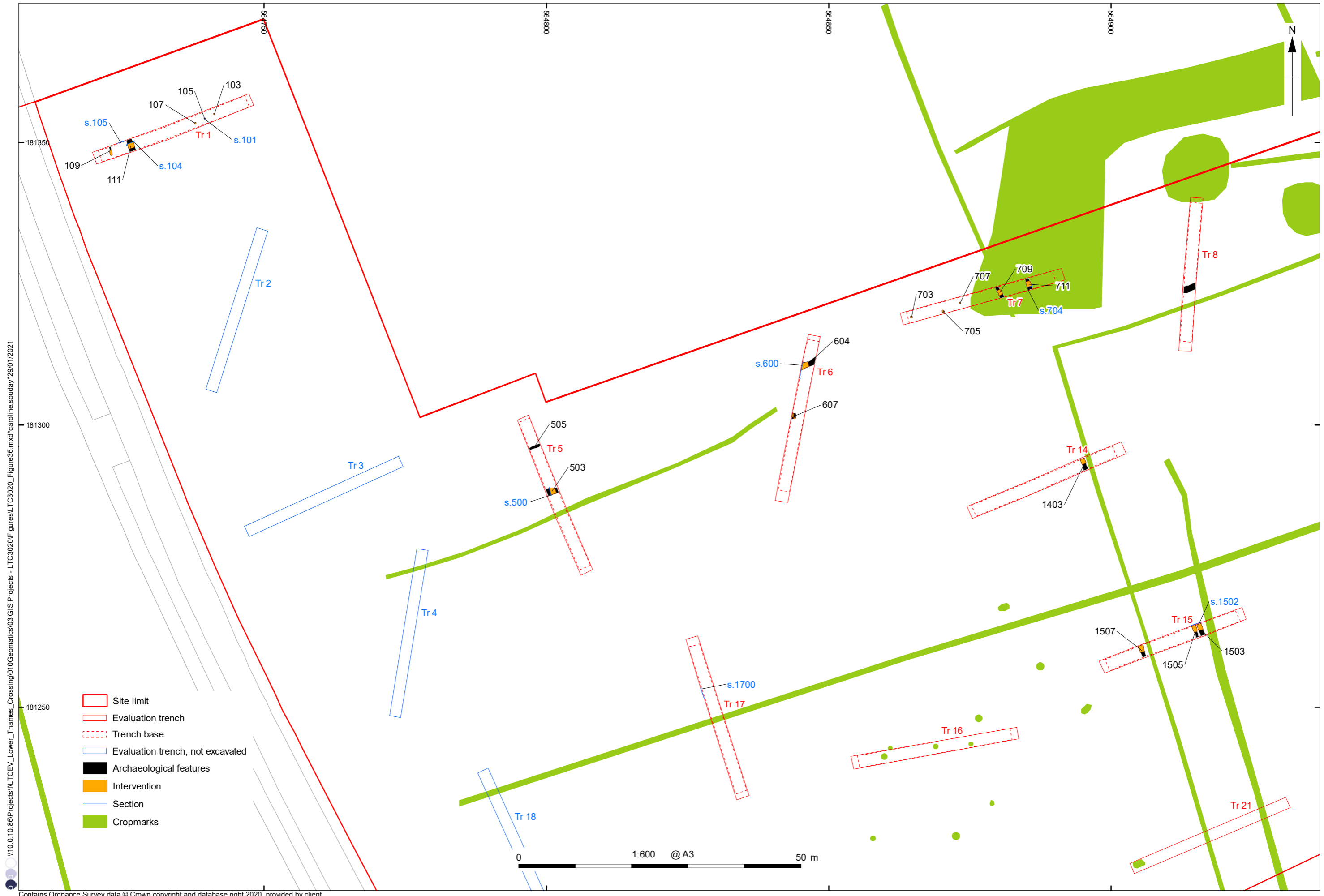

Figure 35: Sections, Trenches 88, 95, 96, 102 and 104  
Document Number: HE540039-BAL-GEN-GEN-REP-HER-00032 Page 228 of 245  
Rev: P01





\\10.0.10.86\Projects\Lower\_Themes\_Crossing\01\0\aeomatics\03\GIS\Projects - LTC3020\Figures\TC3020\_Figure36.mxd\*caroline.souday\*29/01/2021

Contains Ordnance Survey data © Crown copyright and database right 2020, provided by client

Figure 36: Detailed plan of Trenches 1, 5-7, 14, 15 and 17

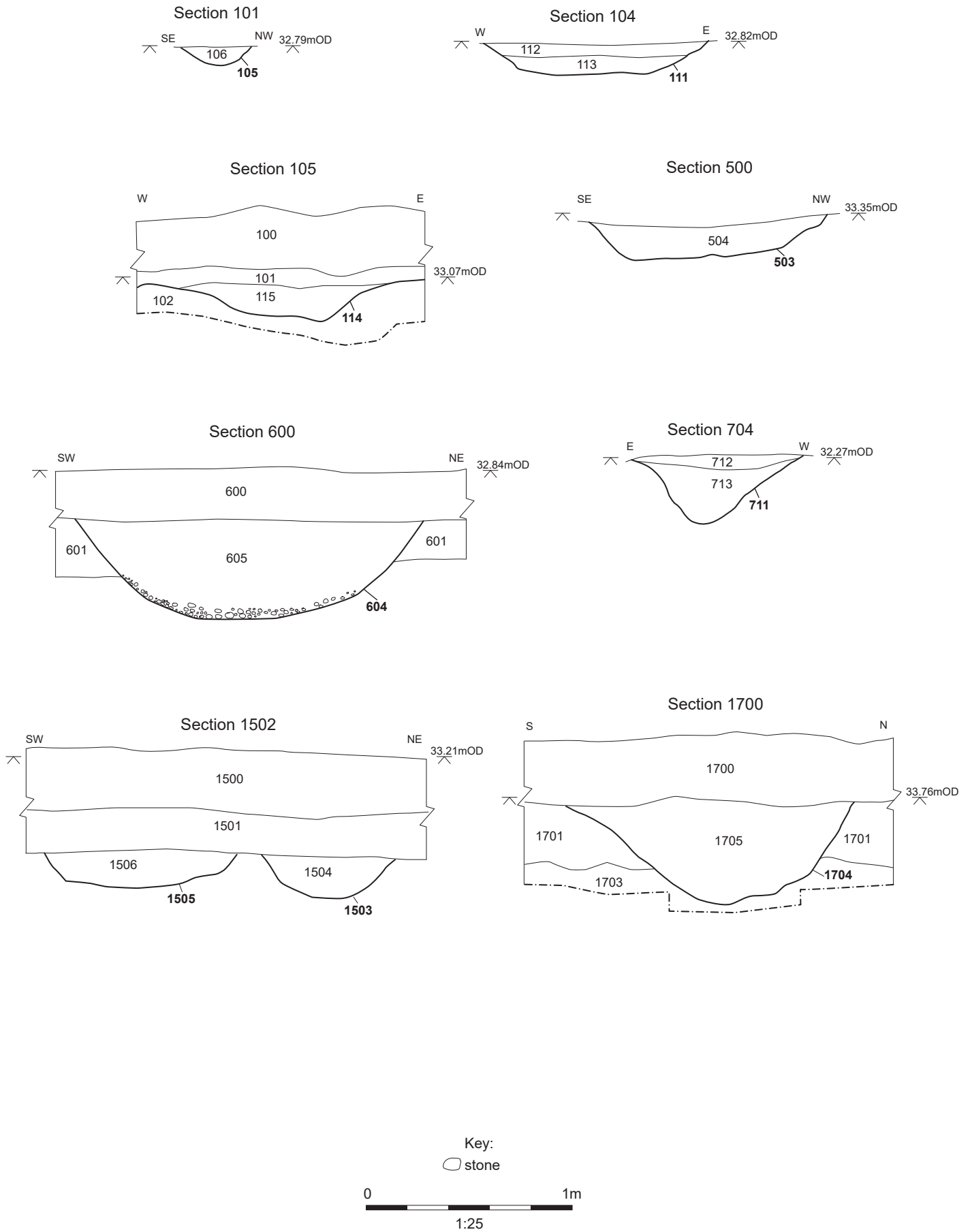
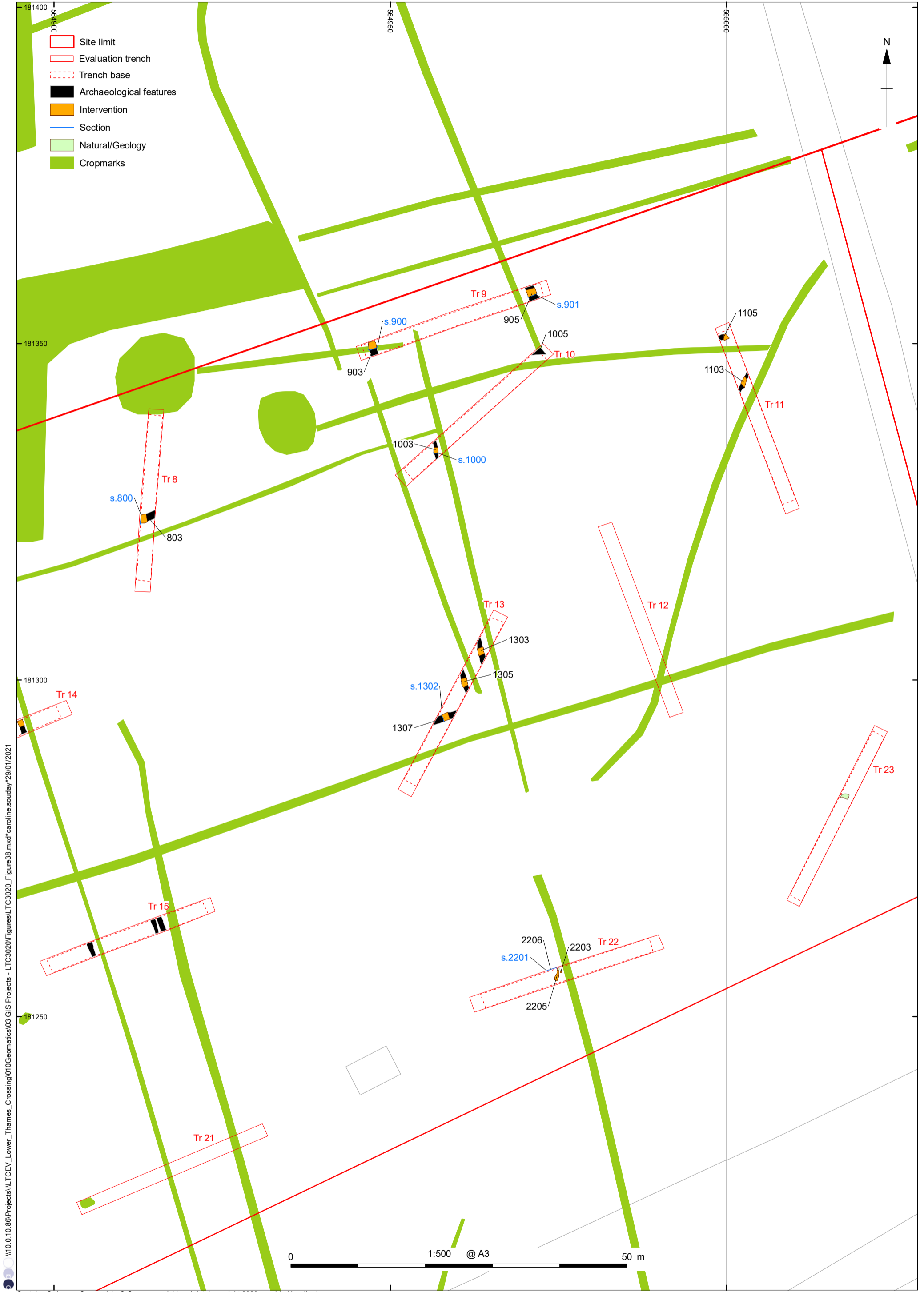

Figure 37: Sections, Trenches 1, 5-7, 15 and 17



\\10.0.10.86\Projects\Lower\_Thames\_Crossing\010\Geomatics\03 GIS Projects - LTC3020\Figures\LTC3020\_Figure38.mxd\*caroline.souday\*29/01/2021

Contains Ordnance Survey data © Crown copyright and database right 2020, provided by client

Figure 38: Detailed plan of Trenches 8-11, 13 and 22

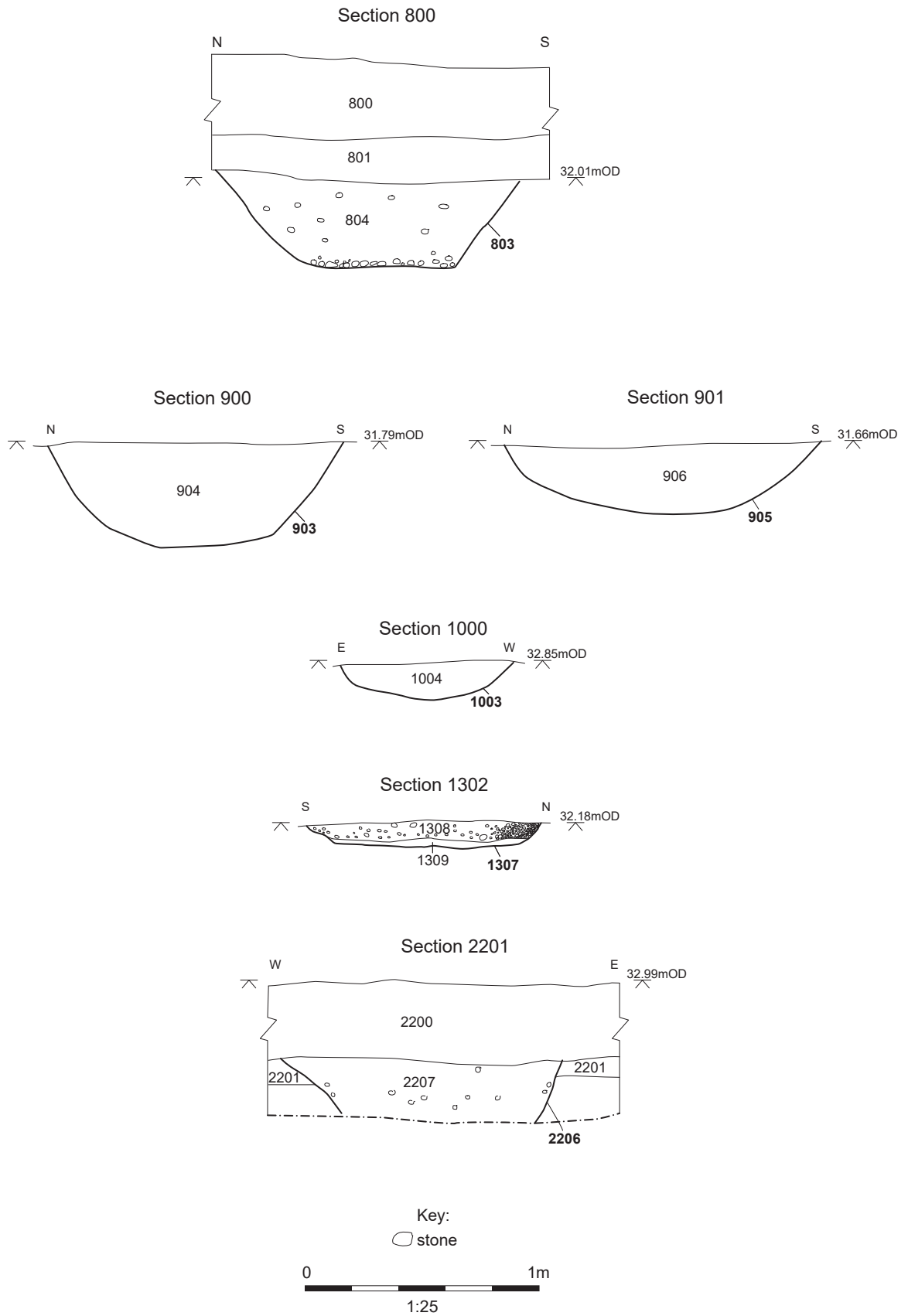
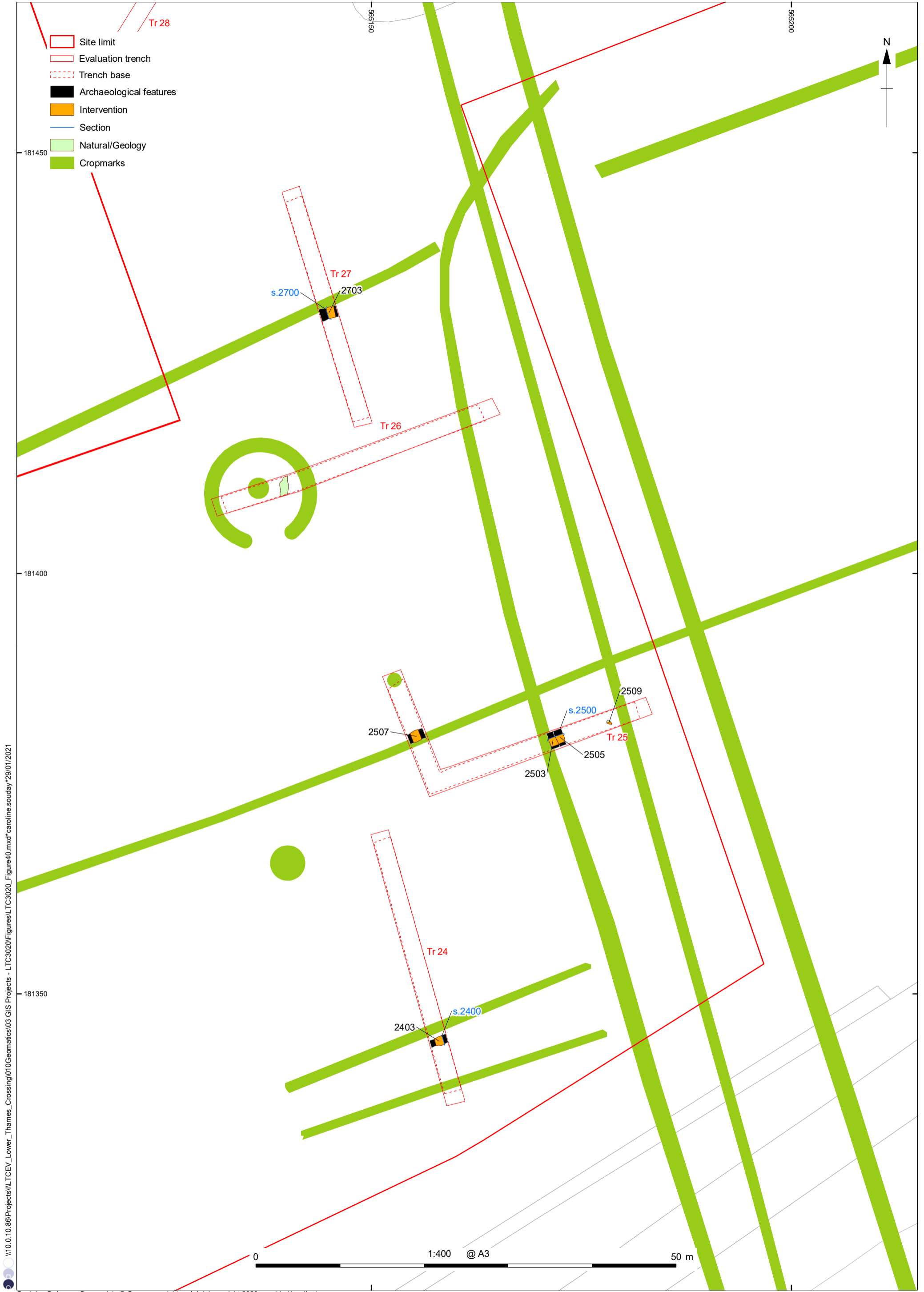

Figure 39: Sections, Trenches 8-10, 13 and 22



\\10.0.10.86\Projects\10.86\Projects\Lower\_Thames\_Crossing\10\Geomatics\03 GIS Projects - LTC3020\Figures\LTC3020\_Figure40.mxd\*caroline.souday\*29/01/2021

Contains Ordnance Survey data © Crown copyright and database right 2020, provided by client

Figure 40: Detailed plan of Trenches 24, 25, and 27

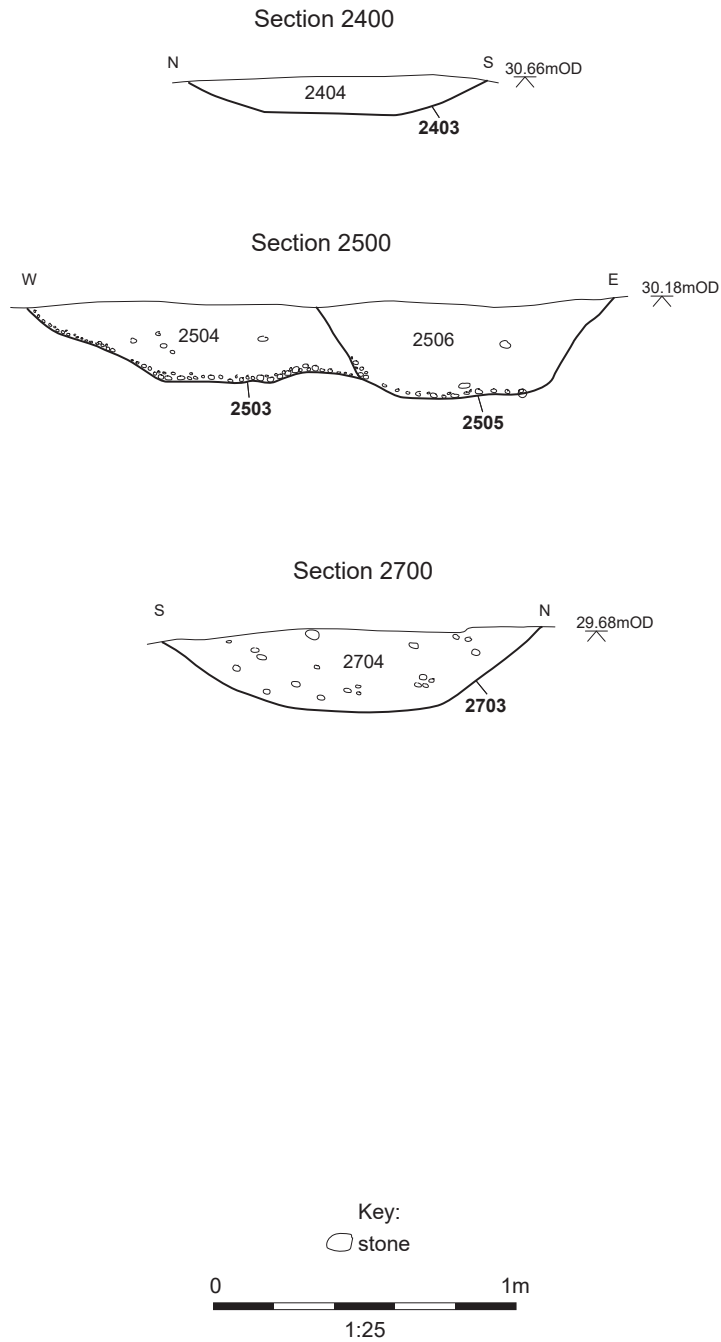
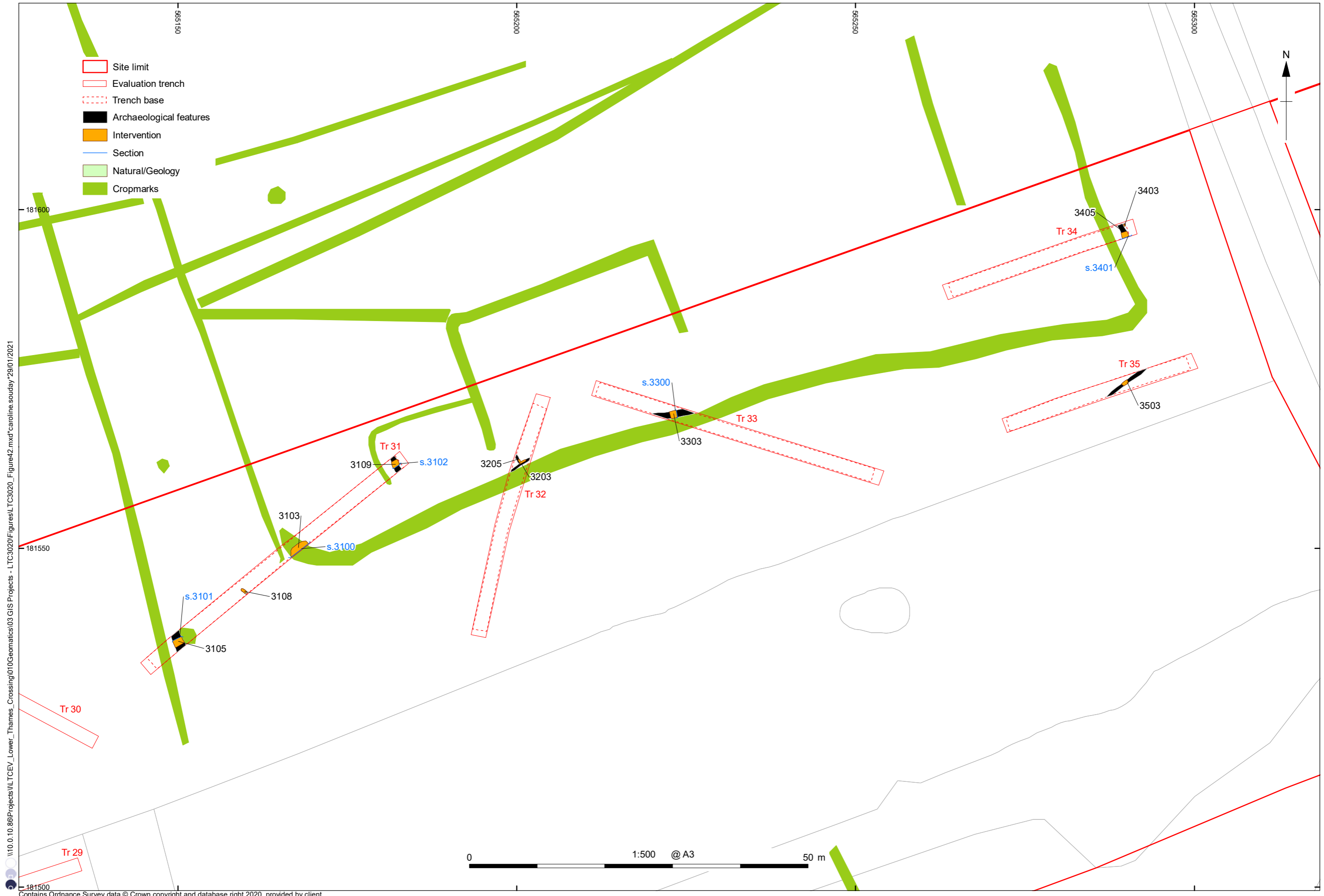

Figure 41: Sections, Trenches 24, 25 and 27



\\10.0.10.86\Projects\IL TCEV\_Lower\_Thames\_Crossing\010\geomatics\03 GIS Projects - L TC3020\Figures\TC3020\_Figure42.mxd\*caroline.souday\*29/01/2021

Contains Ordnance Survey data © Crown copyright and database right 2020, provided by client

Figure 42: Detailed plan of Trenches 31-5

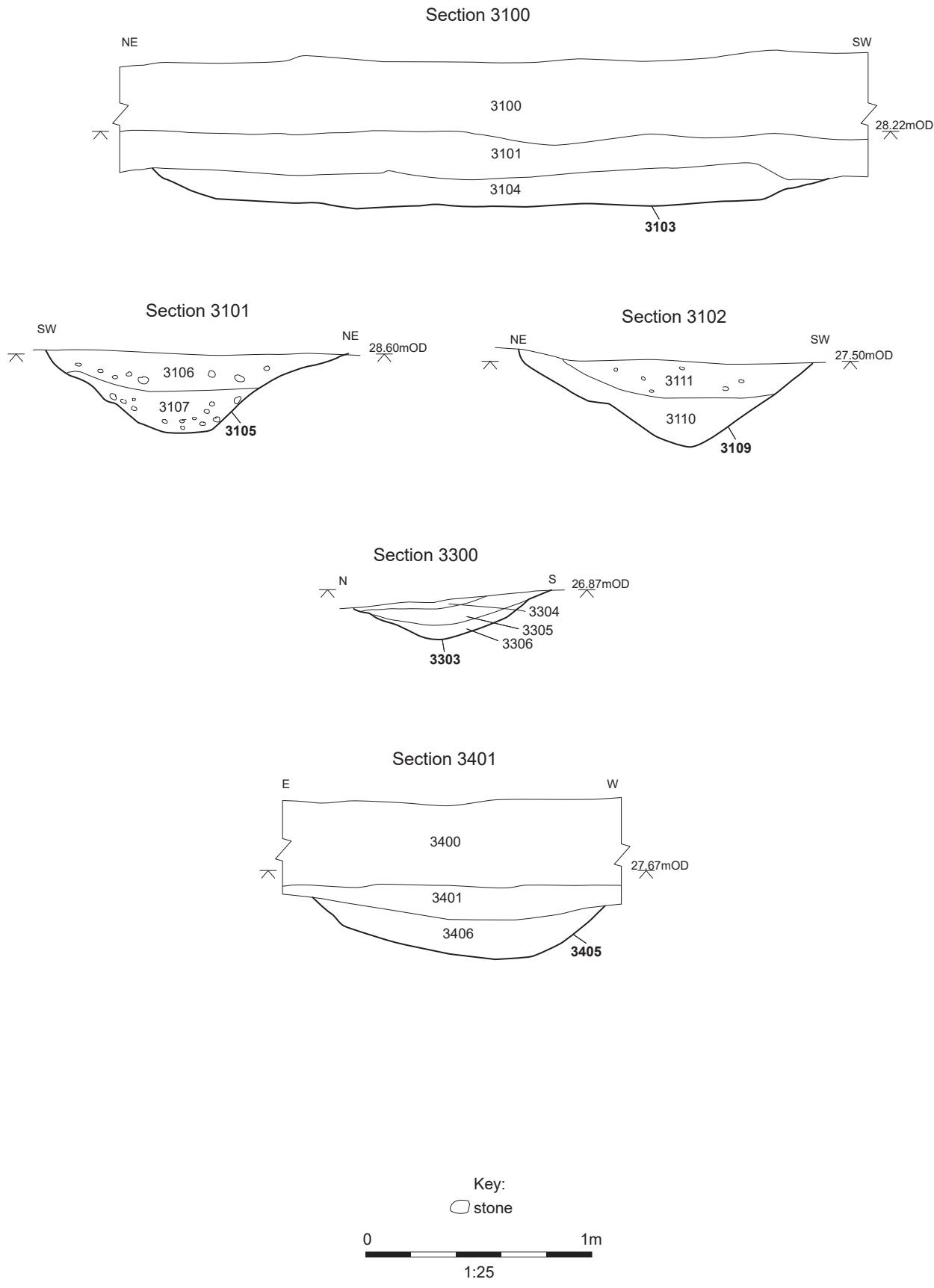

Figure 43: Sections, Trenches 31, 33 and 34  
Document Number: HE540039-BAL-GEN-GEN-REP-HER-00032 Page 236 of 245  
Rev: P01





Plate 1: Trench 148, looking east



Plate 2: Ditch 15002, looking south-east



Plate 3: Section 14100 through ditches in Trench 141, looking south



Plate 4: Ditch 14309, looking west



Plate 5: Ditch 14002, looking north-east



Plate 6: Cremation 13610, looking north-west



Plate 7: Ditch 13502, looking north-east

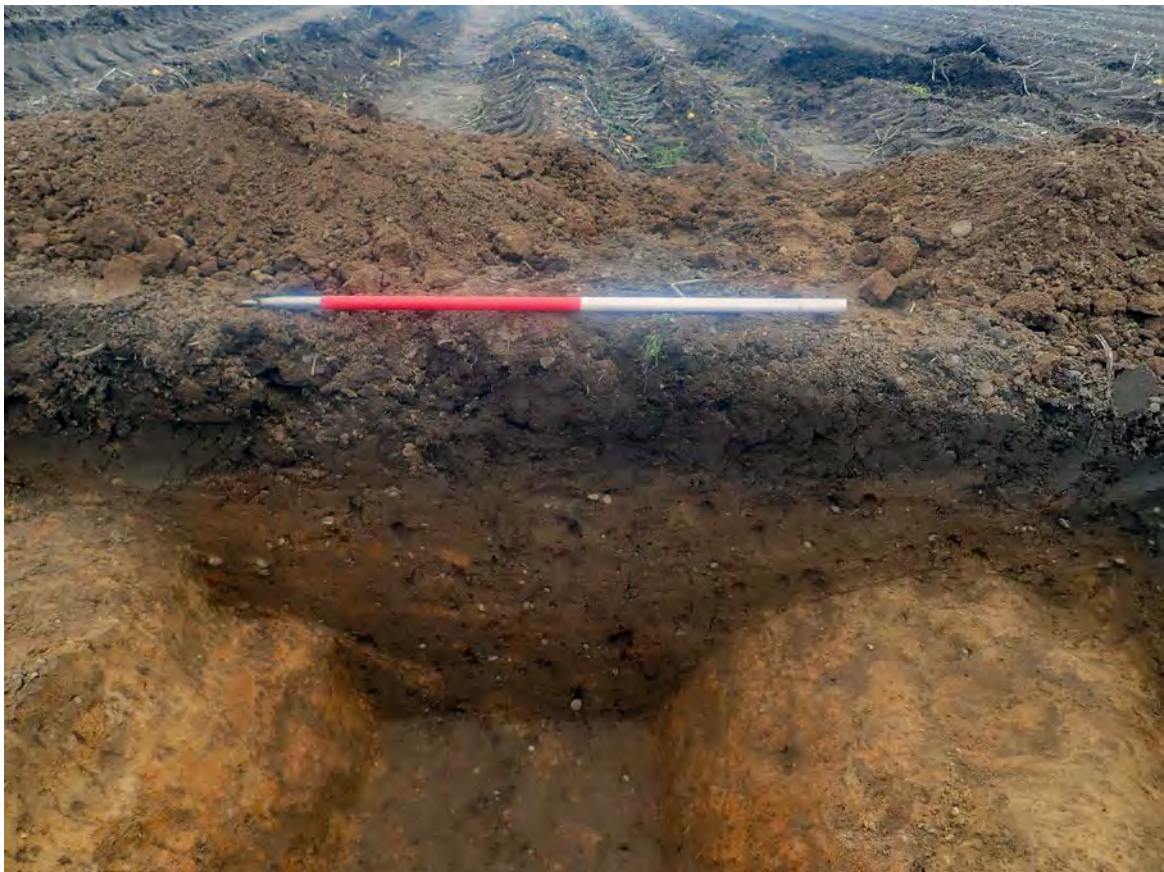

Plate 8: Ditch 18606, looking west



Plate 9: Posthole 4313, looking east



Plate 10: Pit 7603, looking east



Plate 11: Feature 9804, looking south-west



Plate 12: Ditch 8406, looking south



Plate 13: Pit 10404, looking north-west



Plate 14: Pottery dump in pit 10404



Plate 15: Ditches 11104 and 11106, looking north



Plate 16: Postholes 103, 105 and 107, looking north-west





Plate 17: Pit or posthole 703, looking east



Plate 18: Ditch 3105, looking north

**COVER SHEET**

<b>Title:</b>	<b>Archaeological Evaluation Report for Trial Trenching of Land Parcel 3 Hornsby Lane, Orsett Heath, Essex</b>
<b>Project Name:</b>	<b>Lower Thames Crossing Enabling Works</b>
<b>Ref No:</b>	<b>HE540039-BAL-GEN-GEN-REP-HER-00022</b>
<b>Revision No:</b>	<b>PO1</b>
<b>Review Date:</b>	<b>27<sup>th</sup> March 2020</b>
<b>Status:</b>	<b>S3</b>
<b>No. of Pages</b>	<b>237</b>

<b>Rev</b>	<b>Date of Issue</b>	<b>Revision Status</b>	<b>Originator</b>	<b>Checker</b>	<b>Approver</b>
PO1	21.01.2020	S3 For Review and Comment	Jack Kilburn	Paulo Pinho	George Pargeter



# Lower Thames Crossing

Archaeological Evaluation Report for Trial Trenching of  
Land Parcel 3  
Hornsby Lane, Orsett Heath, Essex

Document Number: HE540039-BAL-GEN-GEN-REP-HER-00022

**March 2020**



Revision	Production Date	Prepared by	Checked by	Approved for release by	Sections revised
1.1	4th March 2020	Kirsty Smith Oxford Archaeology	Edward Biddulph Oxford Archaeology		
1.2	27th March 2020		Steve Lawrence Oxford Archaeology		

This Evaluation Report has been prepared for Highways England in accordance with the terms and conditions of appointment stated in the Lower Thames Crossing (LTC) Technical Partner Contract. LTC cannot accept any responsibility for any use of or reliance on the contents of this document by any third party.

# Contents

---

Section	Page
<b>Summary</b> .....	<b>9</b>
<b>Acknowledgements</b> .....	<b>11</b>
<b>1 Introduction</b> .....	<b>12</b>
1.1 Project details and scope of work .....	12
1.2 Location, topography and geology .....	13
1.3 Previous investigations .....	13
1.4 Archaeological and historical background .....	14
<b>2 Project Aims</b> .....	<b>18</b>
2.1 General aims .....	18
2.2 Specific objectives .....	19
<b>3 Methodology</b> .....	<b>20</b>
3.1 Constraints .....	20
3.2 Methodology for the evaluation .....	20
<b>4 Results</b> .....	<b>22</b>
4.1 Introduction and presentation of results .....	22
4.2 General soils and ground conditions .....	22
4.3 General distribution of archaeological deposits .....	23
4.4 Trench 1 .....	24
4.5 Trench 2 .....	24
4.6 Trench 3 .....	24
4.7 Trench 4 .....	25
4.8 Trench 5 .....	25
4.9 Trench 6 .....	25
4.10 Trench 8 .....	26
4.11 Trench 9 .....	26
4.12 Trench 11 .....	26
4.13 Trench 12 .....	26
4.14 Trench 13 .....	27
4.15 Trench 15 .....	27
4.16 Trench 17 .....	28
4.17 Trench 18 .....	28
4.18 Trench 21 .....	28
4.19 Trench 24 .....	28
4.20 Trench 26 .....	29
4.21 Trench 27 .....	29
4.22 Trench 28 .....	29
4.23 Trench 29 .....	29
4.24 Trench 30 .....	29
4.25 Trench 32 .....	30
4.26 Trench 33 .....	30
4.27 Trench 35 .....	30
4.28 Trench 36 .....	31
4.29 Trench 37 .....	31

4.30	Trench 38 .....	31
4.31	Trench 39 .....	31
4.32	Trench 40 .....	32
4.33	Trench 41 .....	33
4.34	Trench 42 .....	34
4.35	Trench 43 .....	35
4.36	Trench 45 .....	35
4.37	Trench 46 .....	36
4.38	Trench 47 .....	37
4.39	Trench 48 .....	38
4.40	Trench 49 .....	38
4.41	Trench 50 .....	38
4.42	Trench 55 .....	39
4.43	Trench 56 .....	39
4.44	Trench 57 .....	39
4.45	Trench 58 .....	40
4.46	Trench 60 .....	40
4.47	Trench 61 .....	40
4.48	Trench 70 .....	41
4.49	Trenches 74, 79 and 80.....	41
4.50	Trench 76 .....	41
4.51	Trench 78 .....	42
4.52	Trench 92 .....	42
4.53	Trench 98 .....	42
4.54	Trench 107 .....	42
4.55	Trenches 109, 110 and 111.....	42
4.56	Trench 113 .....	43
4.57	Trench 114 .....	43
4.58	Finds summary.....	44
4.59	Environmental and osteological summary .....	46
<b>5</b>	<b>Discussion .....</b>	<b>48</b>
5.1	Reliability of field investigation.....	48
5.2	Interpretation .....	49
5.3	Evaluation objectives and results .....	53
<b>Appendix A</b>	<b>Trench Tables .....</b>	<b>55</b>
<b>Appendix B</b>	<b>Finds Reports .....</b>	<b>131</b>
<b>Appendix C</b>	<b>Environmental Reports.....</b>	<b>161</b>
<b>Appendix D</b>	<b>References.....</b>	<b>176</b>
<b>Appendix E</b>	<b>Abbreviations and Glossary.....</b>	<b>180</b>
<b>Appendix F</b>	<b>Site Summary Details .....</b>	<b>181</b>

## Figures

Figure 1 – Site location

Figure 2 - Plan of trench layouts and cropmark features, overlain on the 1st Edition OS map 1897

Figure 3 - Plan of trench layouts, cropmark features and archaeological features (west)

Figure 4 - Plan of trench layouts, cropmark features and archaeological features (central north)

Figure 5 - Plan of trench layouts, cropmark features and archaeological features (central south)

Figure 6 - Plan of trench layouts, cropmark features and archaeological features (east)

Figure 7 - Plan of Trenches 1, 2, 3, 5, 6 and 8

Figure 8 - Sections (Trenches 1, 2, 3, 5, 6 and 8)

Figure 9 - Plan of Trenches 4, 6, 8 and 9

Figure 10 - Sections (Trenches 4, 6 and 9)

Figure 11 - Plan of Trenches 11, 12 and 13

Figure 12 - Sections (Trenches 11, 12 and 13)

Figure 13 - Plan of Trench 15

Figure 14 - Section (Trench 15)

Figure 15 - Plan of Trenches 18, 19, 24, 25 and 26

Figure 16 - Sections (Trenches 18 and 26)

Figure 17 - Plan of Trenches 16, 17, 21, 22, 23, 24, 27 and 28

Figure 18 - Sections (Trenches 17, 21, 24 and 27)

Figure 19 - Plan of Trenches 28, 29 and 30

Figure 20 - Sections (Trenches 29 and 30)

Figure 21 - Plan of Trenches 32, 33, 35, 36 and 37

Figure 22 - Sections (Trenches 32, 33, 35 and 36)

Figure 23 - Plan of Trenches 38, 92, 107 and 108

Figure 24 - Sections (Trenches 92 and 107)

Figure 25 - Plan of Trenches 39, 40 and 43

Figure 26 - Sections (Trenches 39 and 40)

Figure 27 - Plan of Trenches 41, 42, 45 and 46

- Figure 28 - Sections (Trenches 41, 42, 45 and 46)
- Figure 29 - Plan of Trenches 56, 57 and 58
- Figure 30 - Sections (Trenches 56, 57 and 58)
- Figure 31 - Plan of Trenches 47, 48, 49, 60 and 61
- Figure 32 - Sections (Trenches 47, 48, 49 and 61)
- Figure 33 - Plan of Trenches 50, 51, 62 and 63
- Figure 34 - Sections (Trench 50)
- Figure 35 - Plan of Trenches 54 and 55
- Figure 36 - Section (Trench 55)
- Figure 37 - Plan of Trenches 75 and 76
- Figure 38 - Section (Trench 76)
- Figure 39 - Plan of Trenches 70 and 78
- Figure 40 - Sections (Trenches 70 and 78)
- Figure 41 - Plan of Trenches 74, 79 and 80, overlain on the 1st Edition OS map 1897
- Figure 42 - Sections (Trenches 74 and 79)
- Figure 43 - Plan of Trenches 109, 110 and 111
- Figure 44 - Sections (Trenches 109, 110 and 111)
- Figure 45 - Plan of Trenches 98 and 114
- Figure 46 - Sections (Trench 114)
- Figure 47 - Condition of identified specimens, expressed as a percentage of NISP



## Plates

- Plate 1 - Ditch 1103 facing south-east
- Plate 2 - Cremation pit 1509 with grave goods
- Plate 3 - Ditch 1513 facing north-west
- Plate 4 - Ditch 1803 facing north-west
- Plate 5 - Pit 3303 facing north-east
- Plate 6 - Oven pit 3914 facing south-east
- Plate 7 - Section 4201 of large pit 4205 facing north-east
- Plate 8 - Kiln 4503 facing south-west
- Plate 9 - Ditches 4517 and 4514 facing north-west
- Plate 10 - Pit 4606 facing south-west
- Plate 11 - Pit 4608 facing north-west
- Plate 12- Pit 4709 facing east
- Plate 13- Kiln 4704 facing north-east
- Plate 14 - Ditch 7003 facing north
- Plate 15 - Ditch 7805 facing north
- Plate 16 - Ditch 7903 facing south

## Tables

- Table 1 - Summary and quantification of the pottery by context
- Table 2 - Summary of CBM forms and dating
- Table 3 - Summary of fired clay by context
- Table 4 - The flint assemblage
- Table 5 - The flint assemblage by context type
- Table 6 - Summary of glass finds
- Table 7 - Summary of metal finds
- Table 8 - Details of worked stone
- Table 9 - Burnt Bone - Osteological Summary
- Table 10 - Summary of Fragmentation (deposit 1507)

Table 11 - Cremation 1507 - summary of identified elements and bone weights per spit

Table 12 - Assessment of charred plant remains flots

Table 13 - Total NISP (Number of Identified Specimens) and NSP (Number of Specimens)

Table 14 - Non-species data recorded from the specimens (NSP) in the assemblage

Table 15 - Total NSP and weight of specimens from each context

## Summary

---

Oxford Archaeology was commissioned by Balfour Beatty on behalf of LTC to undertake a trial trench evaluation of Land Parcel 3 of the Lower Thames Crossing Pre-Enabling Works. Land Parcel 3, also known as Hornsby Lane, is located c 100m east of the hamlet of Orsett Heath within the county of Essex and Thurrock unitary authority (NGR 564442 180214). The evaluation comprised the excavation of 116 trenches that were accessible out of a total of 166 trench locations specified in the written scheme of investigation. The fieldwork was completed between the 7th December 2019 and the 15th January 2020.

The evaluation identified the shallow remains of a putative mortuary enclosure in the north-west corner of the site. The ditches associated with this feature survived to a maximum depth of up to 0.23m and contained no dating evidence or other artefactual evidence to inform the interpretation.

Thirty-four sherds of late Neolithic/early Bronze Age pottery were found in a ditch terminus or pit in Trench 18 in western part of the site. The pottery from this feature included large fragments of a beaker vessel.

Several late Bronze Age/early Iron Age features were identified on the site. This included a NW-SE aligned ditch in Trench 42, a north-south aligned ditch in Trench 78 and a possible curvilinear ditch in Trench 114.

A putative Roman settlement was located on the site, with cropmark evidence that extended beyond the evaluation area identifying a large NW-SE aligned enclosure with an associated trackway, internal subdivisions and further enclosures to the south-east. This was confirmed by the current investigation, which encountered Roman pottery in several of the ditches, along with late Iron Age/early Roman domestic activity in the area of Trenches 39-45. The large, main enclosure with associated trackway was possibly created in the early to mid-Roman period and was then recut several times. It is likely that settlement activity continued in the eastern part of this enclosure (Trenches 39-45) during the middle to later Roman period. Trenches 45 and 47 in the south-eastern part of the enclosure contained several pottery kilns. This settlement appears to have been involved in arable and pastoral farming, crop processing, pottery production and possibly butchery of animals on an industrial scale. This enclosure may have continued in use until the later Roman period. The NW-SE aligned field boundaries and trackway in the southern part of the site were undated but may be contemporary with the main enclosure.

Trenches 40 and 43 in the central, northern part of the site uncovered a colluvial layer and in both cases this layer contained Roman pottery. These trenches are located in an area of dry valley, where the colluvial layer may have acted as a protective layer, preserving this part of the site from truncation from modern arable farming.

The evaluation identified numerous individual features, including a large quarry pit in the north-western corner of the site, although this was undated. In terms of the other pit-like features that were shown as cropmarks, the majority of these were not identified within the trenches and are likely to have been variations in the natural geology. It is also possible that the aerial survey identified pits that may have been shallow and modern ploughing may have wholly truncated these features.

A later post-medieval ENE-WSW field boundary was identified in the eastern part of the site along with a north-south post-medieval trackway. These features may be associated with Heath Place, the farm to the east of Hornby Lane.

## Acknowledgements

---

Oxford Cotswold Archaeology would like to thank the client, Balfour Beatty for commissioning this project and managing the site safety and attendances. Thanks are also extended to Highways England and the Historic Environment Consultants (Richard Havis and Katie Lee- Smith) of Place Services for Essex County Council advising the Borough of Thurrock, for monitoring and providing advice throughout the project.

The project was managed for Oxford Cotswold Archaeology by Steve Lawrence. The fieldwork was directed by Mark Dodd and Anna Moosbauer, who were supported by Robert McIntosh, Ashley Strutt, Adrian Arenas, Eilidh Barr, Majbritt Bengston, Chris Brown, Florencia Cabral, Molly Day, Fanny Dubuc, Lara Tonizzo Feligioni, Mat Ferron, Susanna Feron, Dan Firth, James Fish, Stephen Foster, Hazel Fransch, Barbara Graham, Pawel Jablonski, Kerree Kendall, Megan Lillington, Chloe Merrett, Adam Moffat, Rebecca Pridmore, Enrico Ravanetti, Daniel Sendek, Jana Smirinova, Philip Terry, Ioannis Thanos and Zsuzsanna Veres. Site survey was undertaken by Rachel Alexander and Caroline Souday and digitising was carried out by Benjamin Brown, Aidan Farnan, Conan Parsons, Charles Rousseaux and Simon Batsman.

# 1 Introduction

---

## 1.1 Project details and scope of work

- 1.1.1 The Lower Thames Crossing Project is located between the A2 in Kent and the M25 in the London Borough of Havering. It will run underneath the River Thames in a tunnel and emerge on the northern side of the river at East Tilbury. From the North Portal the road will run to the M25 at Junction 29 via the A13 and pass in between North and South Ockendon. The development of the project is being managed by LTC, a partnership between Highways England and a consultancy joint venture set up to oversee the scheme.
- 1.1.2 A programme of archaeological trial trenching was started in the Essex part of the scheme in November 2019. A scheme-wide specification for trial-trenching was written by LTC (Highways England 2018), and in July 2019 LTC commissioned Balfour Beatty to deliver the pre-enabling works. Balfour Beatty appointed Oxford Archaeology (hereafter OA) to prepare a project-wide written scheme of investigation for the scheme, which (at the request of the Key Archaeological Stakeholders) is divided into two parts, one for the Kent section, the other for Essex and Havering (Oxford Archaeology 2019a, 2019b).
- 1.1.3 Following completion of the project-wide WSIs, Oxford Archaeology was also instructed to prepare a series of site-specific or group-site specific WSIs for approval by the key archaeological stakeholders in advance of trial trenching to inform the Development Consent Order (DCO). A detailed WSI was issued for Land Parcel 3 prior to the trial trenching (Oxford Archaeology 2019c). The WSI details the archaeological background and potential within Land Parcel 3 (Oxford Archaeology 2019c). It also outlined the archaeological aims and objectives appropriate to the investigation of this land parcel and set out the methodology by which LTC's archaeological contractors (Oxford Archaeology and Cotswold Archaeology) implemented the requirements for archaeological trial trenching.
- 1.1.4 The fieldwork was undertaken between the 7th December 2019 and the 15th January 2020. The fieldwork work was undertaken in accordance with local and national planning policies. All work also followed the MoRPHE Project Manager's guide (Historic England 2015), and the Code of Conduct of the Chartered Institute for Archaeologists (CIfA). The archaeological works adhered to the Standards and guidance for archaeological evaluation, excavation and archiving (CIfA 2014a; CIfA 2014b).
- 1.1.5 The work was monitored by Richard Havis and Katie Lee-Smith, Place Services, ECC advising the Borough of Thurrock.

## 1.2 Location, topography and geology

- 1.2.1 Land Parcel 3 is located c 100m east of the hamlet of Orsett Heath (Fig. 1) within the county of Essex and Thurrock unitary authority (centred on NGR TQ 64442 80214). The land parcel has a straight southern edge and three projecting sections to the north and covers an area of 22.98ha. This land parcel is located 200m south of the A1013 and 400m south of the A13 and is bounded to the west and north-west by fields. It is located to the south of Whitecroft care home and is bounded to the north-east by Heath Place, to the east by a footpath and hedgerow and to the south by an agricultural field. Hornsby Lane, a single-track road, passes through this land parcel and a small farm with a farmhouse and several outbuildings is located within the south-western part of the site.
- 1.2.2 The bedrock geology of Land Parcel 3 is Thanet Formation (sand). The superficial geology of the land parcel is varied with the majority of the area covered by sand and gravel of the Boyn Hill Gravel Member. In addition, a small area in the central part of the land parcel is underlain by Head (clay, silt, sand and gravel). This colluvial layer was formed by fine grained materials collecting at the base of a slope (BGS 2019).
- 1.2.3 The land parcel is currently in use as part of two large arable fields and several smaller enclosed areas associated with Whitecroft care home, Heath Place and the small farm (Rose Cottage) north of Hornsby Lane. Not all of these were accessible for this phase of fieldwork. The wider area has also been bisected by the A13, A1013 and the A1089, which has displaced the historical field boundaries in this locality.
- 1.2.4 The land parcel is situated partly within a dry valley with areas of higher ground towards the southern and northern edge where the ground is c 24-25m aOD. A dry valley, orientated east-west is situated along the centre line of the land parcel, with the lowest point at c 20m aOD. No permanent streams are marked in the immediate vicinity of the land parcel, but a drainage ditch is located 700m south-east of the land parcel. This drainage ditch may be the remnants of a stream which joined another at Linford (1.5km south-east of the land parcel) further down the valley. There is a pond of unknown antiquity south of Heath Place, just north of the land parcel.

## 1.3 Previous investigations

- 1.3.1 No known below-ground archaeological investigation has been undertaken within this land parcel.

## 1.4 Archaeological and historical background

- 1.4.1 The chronological summary of known archaeology given below is taken from the detailed WSI for Land Parcel 3 (Oxford Archaeology 2019c). Land Parcel 3 or Hornsby Lane is referred to as the 'site' hereafter. The site is situated on the terrace to the south of the Mar Dyke valley where Holocene prehistoric features, findspots and cropmarks have been identified. The cropmarks that have been recorded within the land parcel are those mapped by the aerial investigation and mapping report (Place Services 2019). These cropmarks are shown on figure 2.
- 1.4.2 Land Parcel 3 is situated on the terrace to the south of the Mar Dyke valley, where a number of prehistoric features, findspots and cropmarks have been identified. The undated cropmark features that were identified within the area of the land parcel may date from the later prehistoric or Roman period and this is discussed below.
- 1.4.3 **Palaeolithic.** A number of Palaeolithic finds have been recorded in the vicinity of Land Parcel 3. The closest of these was located c 20m east of the site including four handaxes, one retouched flake and nine flakes. Other Palaeolithic finds were recorded 0.4-0.6km south-west of the site, including flint flakes.
- 1.4.4 **Mesolithic.** Several Mesolithic finds have been identified within the southern part of the land parcel, including two flint blades. Mesolithic find spots have also been recorded 0.6-1km south of the site.
- 1.4.5 **Neolithic.** A scheduled early Neolithic causewayed enclosure is located 0.3km north-east of the land parcel. When this was excavated in 1975, the pottery found within the causewayed enclosure was of Mildenhall-type dating to the early Neolithic along with flints of the same date. The secondary ditch silts of the enclosure also contained a small quantity of late Neolithic/early Bronze Age pottery (Hedges and Buckley 1978, 219-308).
- 1.4.6 A putative east-west aligned mortuary enclosure is located within the north-western part of the land parcel. These monuments are oblong-shaped and surrounded by straight ditches and a perimeter bank and are aligned roughly east-west. Mortuary enclosures are extremely rare (with only around 35 examples in England) and they may have been used as ceremonial monuments during the early and middle Neolithic (3200-2500 BC). These monuments are usually located within a wider ceremonial landscape of other Neolithic features. If this is a mortuary enclosure, this may be one of the earliest features within this extensive cropmark sequence and is potentially highly significant. It is likely to have been contemporary with the nearby early Neolithic causewayed enclosure.
- 1.4.7 A number of Neolithic flints were recorded across several fields along the southern boundary of the land parcel and included blades, scrapers, arrowheads, cores and hammer stones. The largest number of these flints were collected from NGR 564700 180000, which is located immediately south of the land parcel. It is possible that further Neolithic activity may be found within the south-eastern part of the site.



- 1.4.8 **Bronze Age.** The cropmark of a possible ring-ditch which may well represent a ploughed-out round barrow was identified only 300m north-west of Land Parcel 3 (Place Services 2019, site 21). The cropmarks of two ring-ditches are located 300m east of the land parcel and these may date to the Bronze Age.
- 1.4.9 **Iron Age.** The Neolithic causewayed enclosure located 0.3km north-east of the site was overlain by an unenclosed early Iron Age site and a middle Iron Age sub-rectangular enclosure (Hedges and Buckley 1978, 219-308). Cropmarks including pits, linear features and ring ditches extend from the area of the scheduled early Iron Age enclosure (Place Services 2019, sites 17A, 17B and 72). Among these, an enclosure 200-300m north of the east end of the site is likely to date to the Iron Age period. Another early Iron Age open settlement was excavated 800m north-east of Land Parcel 3. This excavation found a scatter of postholes and pit, including a storage pit with a basal deposit comprising carbonized grain (Wilkinson 1988, site 1).
- 1.4.10 A large number of intercutting cropmarks are present within Land Parcel 3 and it is likely that multiple periods are represented, possibly dating from the Neolithic, Iron Age and Roman period (Place Services: site 20). There appears to be several phases of occupation within Land Parcel 3. One phase is possibly associated with a north-south trackway within the western part of the land parcel. A number of east-west linear features within the land parcel may be associated with this north-south trackway or they may be far later in date. There are also several small enclosures within the land parcel, which may belong to an earlier phase. Some of the earlier cropmark features appear to have been cut by a large NW-SE aligned rectilinear enclosure of possible Roman date (see below).
- 1.4.11 A large quantity of high-status Iron Age material was recovered by metal detectorists within a field close to Hornsby Lane and within the northern part of the land parcel. This findspot may be associated with an Iron Age phase of occupation which may pre-date the large rectilinear enclosure located in the area of the land parcel (discussed below).
- 1.4.12 A cello-shaped cropmark enclosure is located c 200m south of the land parcel, which contains several ring ditches, possibly representing house enclosures (Place Services 2019, sites 22 and 32). This cropmark enclosure was characterised as being of later Iron Age (or Roman) date. A cropmark trackway runs north-westwards from it. Further east, and 300m south-east of Land Parcel 3 another enclosure was identified. This rectangular enclosure with a sub-rectangular annexe may be Iron Age to Roman in date (Place Services 2019, site 56).
- 1.4.13 **Roman period.** The route of a possible Roman road is projected roughly north-south and c 0.5km east of Land Parcel 3. It is possible that additional Roman roads or trackways cut roughly east-west across the terrace as other Roman sites have been identified 1-1.5km north-west of the land parcel.

- 1.4.14 An extensive, rectilinear enclosure, was identified by the aerial survey within the western part of Land Parcel 3 (Place Services 2019, site 20). This large, NW-SE aligned, rectilinear enclosure (250m long by 200m wide) has associated trackways to the south and north, and internal subdivisions. The size and regularity of this enclosure suggest that it could be Roman in date. A number of other linear features surrounding the enclosure run parallel and perpendicular to it and these may be associated field systems and additional enclosures; the possibly Iron Age enclosure has a trackway at right angles to this large enclosure system, so may also have continued in use. A smaller rectilinear enclosure is clipped by the very north edge of the site, and this too is likely to be associated. As discussed above, this enclosure intersects the north-south trackway and its associated east-west linear features, but which is earlier is at present unclear.
- 1.4.15 **Medieval period.** Mid Saxon activity has been identified east and north-east of the land parcel. The Orsett causewayed enclosure was reused as a Saxon funerary monument in the 7th-8th century. A Saxon settlement was also located 1km north-east of the land parcel at Orsett Cock.
- 1.4.16 In the late Saxon and later medieval period the land parcel was located within the parish of Orsett, 1km north of the land parcel. It is likely that in the later medieval period, the land parcel was used as agricultural land associated with this settlement. A number of droeways have been observed as cropmarks within the wider area and it is possible that Hornsby Lane originated as a droeway. Another possible droeway has been identified 150m west of the land parcel. This earthwork comprises a roughly north-south feature with a ditch on either side of a central track. These droeways may have been used to take livestock to and from the marshland to the upland ridge.
- 1.4.17 **Post-medieval period.** Documentary evidence indicates that the land parcel was situated either side of Hornsby Lane which linked the village of Orsett to the hamlet of Orsett Heath. The land parcel was also located c 100m south of the NE-SW road from Stifford to Stanford. The OS map of 1897 (Fig. 2) indicates there was a north-south aligned building at NGR 564251 180016, within the south-western part of Land Parcel 3, which is now demolished. This building was located directly south of the existing 20th century house.
- 1.4.18 There are several late 18th century Grade II listed buildings in close proximity to the land parcel including Heath Cottage, Heath Place and Whitecrofts Farmhouse.

- 1.4.19 In the post-medieval period the land parcel was likely to have been used as agricultural land associated with Orsett Heath and Heath Place. It is very likely that some of the east-west cropmark linear features identified within the land parcel may be field boundaries that date from the medieval or post-medieval period. Some of them appear to be perpendicular to Hornsby Lane and form a regular set of enclosure fields (Fig.2). The north-south cropmark trackway that bisects the land parcel, in the western part of the site continues from an extant field boundary running north to a farm, and this is therefore likely to be post-medieval, or possibly medieval, in origin. Several post-medieval footpaths and trackways were also identified on the aerial survey (Place Services 2019) and historic mapping within the southern and eastern part of the site. These features appear on the Orsett Tithe map of c 1840 (D/CT 264/1a) and so are almost certainly post-medieval in date. Several of the east-west linear features currently assigned as cropmark features (Fig. 2 – green features) may also be post-medieval field boundaries.
- 1.4.20 **Undated.** Apart from the undated enclosures and linear features that have been identified across the land parcel (and tentatively discussed by period above), there are also a number of pits and amorphous features that have been mapped by the aerial survey. It is possible that some of these features could have natural origin, and some may relate to colluvial processes. The swathe of amorphous and pit-like features within the southern part of the land parcel are located on a slope to the south of the dry valley and it is possible that these are quarry pits. The pits with the western and northern part of the land parcel are perhaps more likely to be archaeological given their proximity to other linear features and enclosures.

## 2 Project Aims

---

### 2.1 General aims

2.1.1 The general project aims of the project were as follows:

- To establish the presence or absence of archaeological remains along the line of the scheme, and the extent of any areas where remains appear likely to be absent;
- In areas where archaeological remains are known or suspected, to clarify the reliability of the cropmark or geophysical survey evidence;
- In areas where no archaeological remains are indicated by aerial or geophysical survey, to clarify whether this apparent absence of remains is genuine;
- To determine the degree of complexity of any surviving horizontal or vertical stratigraphy, and in particular, to investigate areas where topography indicates the likelihood of deep deposit sequences for evidence of buried archaeological horizons and palaeo-environmental sequences;
- Where remains are present, to determine the period(s) represented, the extent, state of preservation and character of the archaeological remains;
- To establish the range and state of preservation of archaeological artefacts, and through their recovery and examination, to establish the potential for information about the economy, status and contacts of past inhabitants of the scheme footprint;
- To determine whether palaeo-environmental remains are preserved, and, where these are found, to determine their types (eg charred plant remains, waterlogged remains, molluscan remains), state of preservation and potential for environmental information. This will be achieved through the recovery of samples from sedimentary sequences and archaeological features suitable for assessment of a range of palaeoenvironmental remains (eg charred and waterlogged plant remains, charcoal, insects, pollen, diatoms, ostracods/foraminifera and molluscs) and scientific dating (eg radiocarbon and OSL dating);
- To investigate and record the extent, character and chronology of the sedimentary sequences, in particular those immediately adjacent to and in floodplains, contained within palaeochannels or in dry valleys, and to use the data to refine existing geoarchaeological (predictive) deposit models.
- To place any identified archaeological remains into their local and, where appropriate, regional or national context, and to assess the implications of any such discoveries for our current understanding of settlement and landscape change in the area, including an assessment of the associations of any remains with reference to the historic landscape;
- To provide sufficient information to enable the LTC archaeological advisor, in consultation with the Key Archaeological Stakeholders, to determine the significance of the archaeological assets identified within the land parcel;

- To provide a report upon the discoveries to inform the environmental statement (ES) supporting the Development Consent Order (DCO) and support the preparation of a further archaeological mitigation strategy for the Enabling Works and Construction phases of the scheme;
- Following the DCO, to deposit the report in the public domain, and to generate an accessible and useable archive which will allow future research of the evidence to be undertaken.

## 2.2 Specific objectives

2.2.1 The specific project objectives were as follows:

- To conduct the programme of archaeological investigation within the general research parameters and objectives defined by the revised East of England Research Framework (Medlycott 2011), and to take account of the aims and objectives of the Greater Thames Estuary Historic Environment Research Framework.
- To clarify whether the cropmarks provide an accurate representation of the range, quantity and types of archaeological features present within the parcel;
- To investigate whether the elongated cropmark enclosure in the north-west corner of the land parcel is a Neolithic mortuary enclosure, and to investigate activity carried out within it, whether in the form of peripheral burial, deposits related to visits, flint scatters or reuse for burial or other purposes in later periods.
- To establish the character and date of the extensive pits across the land parcel, and to determine whether these are all of one type or period, or whether they encompass several types and span several periods of activity;
- To establish the extent, character and density of Roman activity within the scheme area, and in particular, whether the undated cropmark enclosures are Roman, and if so, establish their duration of use.
- To establish the date of the possible medieval or post-medieval field boundaries that have been identified within the land parcel;
- To establish whether a possible medieval droveway extends northwards through the land parcel;
- To look for evidence of medieval and post-medieval farmsteads which may have been located along the roadways within the northern and western part of the land parcel.
- To clarify the date of the quarrying in the north-west corner of the site, and whether this is associated with the adjacent large enclosure, as appears likely from the cropmark ditches linking it to the enclosure;
- Should any of the trenches prove to lie within areas of the dry valley that include deep colluvial deposit sequences, to look for buried archaeological horizons within the colluvial sequence. This is likely to be particularly relevant for sites of the late Upper Palaeolithic, Mesolithic and Neolithic periods, but sites of later periods may also survive buried beneath colluvium or Head deposits, or eroded from upslope.

## 3 Methodology

---

### 3.1 Constraints

- 3.1.1 Several constraints limited the area of the land parcel available for trial trenching. This included an east-west abandoned water pipe within the northern part of the land parcel which bisects Hornsby Lane. The water supply diagrams showing below ground fresh water and waste to Rose Cottage and Heath Place were not provided; these may be located along Hornsby Lane. A below-ground telecoms service also follows Hornsby Lane from the north and into Heath Place.
- 3.1.2 There are two sets of high-level pylons, aligned WNW-ESE which bisect the centre of the land parcel. High voltage power lines were also present along the western boundary of the land parcel and another branch which bisects the northern part of the land parcel eastwards towards Heath Place.
- 3.1.3 There was also a moderate potential for unexploded ordnance (UXO) and six ecological constraints within the site, three to the west and three in the centre of the site.
- 3.1.4 These constraints were taken into account when designing the detailed trench layout for the land parcel.
- 3.1.5 In addition, not all of the individual smaller enclosed paddocks, gardens and fields were available for evaluation during this phase. These were included for the trench layout within the WSI but excluded from this phase of excavation. The excluded trenches are not shown in the figures.

### 3.2 Methodology for the evaluation

- 3.2.1 The total land parcel area was 22.98ha, and the area available for investigation, excluding areas of services, hedgerows and other constraints is 21.16 ha. The accessible archaeological trial trenching comprised a total of 116 trenches, most measuring 30m x 2m, but a few measuring a little more or less than this, together representing a 3.95% sample of the area available for trenching. The location of the excavated trenches is shown on Figure 2.
- 3.2.2 The trench design was developed to target cropmark features identified by the aerial mapping report (Place Services 2019), and otherwise to provide even coverage of the blank areas (Fig. 2). Trenches 3, 8, 13, 24, 28, 29, 30, 40, 45 and 56 targeted the main enclosure ditches and ditches 29 and 30 also targeted the possible trackway to the south. Trenches 5, 12, 4, 9, 19 and 39 targeted roughly north-south and east-west aligned linear features in the vicinity of the main enclosure. Trenches 41, 47, 48, 49, 58, 59, 60, 61 and 70 targeted subsidiary rectangular enclosures to the east and south-east of the main enclosure. Trenches 16, 17, 27, 35 and 75-77 targeted additional linear and curvilinear features. Trench 55 targeted a possible NW-SE aligned trackway located in the north-eastern part of the site. Trench 2 targeted the possible mortuary enclosure. A number of discrete features were also targeted by the trenches in the western and southern part of the site.

- 3.2.3 All trenches were located using a Global Positioning System (GPS) prior to machine excavation. All trenches were excavated using a tracked excavator fitted with a toothless bucket under constant archaeological supervision.
- 3.2.4 Revealed features were hand cleaned and sampled by hand excavation. They were recorded as outlined in the approved WSI. All finds were bagged by context throughout the evaluation and were recovered for further investigation.

## 4 Results

---

### 4.1 Introduction and presentation of results

- 4.1.1 The results of the evaluation are presented below and include a stratigraphic description of the trenches that contained archaeological remains. The full details of all trenches with dimensions and depths of all deposits can be found in Appendix A. Finds data and spot dates are presented in Appendix B with the environmental reports presented in Appendix C.
- 4.1.2 Context numbers reflect the trench numbers unless otherwise stated. Thus, pit 102 is a cut within Trench 1, while ditch 304 is a cut within Trench 3.
- 4.1.3 The overall pattern of the recorded cropmarks is shown on Figure 2 along with the trench layout for the site. An overview of the archaeological features and cropmarks is shown in more detail on Figures 3-6. Further detailed plans of the trenches containing archaeological features are shown on Figures 7-45 (odd numbers) and selected sections are shown on Figures 8-46 (even numbers).

### 4.2 General soils and ground conditions

- 4.2.1 The soil sequence across the site was fairly uniform with a natural geology of orangey yellow or yellow-brown silty sand with gravel. The natural that was encountered is the superficial deposits of the Boyn Hill Sand and Gravel, which covers the Thanet Sand in this area.
- 4.2.2 A thin subsoil layer (c 0.1-0.2m thick) of brown silty sand was encountered in the majority of trenches and this overlay the natural geology. This may be the relict remains of a former ploughsoil which has been eroded, probably by the modern ploughing. The subsoil and natural was overlain by a topsoil/ploughsoil which was a dark grey brown silty clay or silty sand which was 0.2-0.4m thick.
- 4.2.3 A possible colluvial layer was encountered in Trenches 40 and 43 (4012, 4301) in the central, northern part of the site. In both cases this layer contained Roman pottery and, in Trench 43, the colluvial layer (4301) was 0.4m thick and overlay the silty sandy subsoil (4309). Context 4301 was found in the area of a possible dry valley where the British Geological Survey record the presence of Head Clay deposits (BGS 2019). This area is the lowest part of the site. The colluvial layer containing Roman material may have moved downslope, suggesting that the Roman pottery in the layer is residual, or that this accumulated during the Roman period.
- 4.2.4 Ground conditions throughout the evaluation were challenging with spells of heavy rain resulting in waterlogged conditions in some trenches. This made the working conditions difficult, occasionally limiting the visibility within trenches. This also meant that it was more difficult to distinguish between archaeological features and natural features.



## 4.3 General distribution of archaeological deposits

- 4.3.1 Archaeological features were located in Trenches 1-6, 8, 9, 11-13, 15, 17, 18, 21, 24, 26, 27-30, 32, 33, 35-43, 45-50, 55, 56-58, 60, 61, 70, 74, 76, 78, 79, 80, 92, 98, 107, 109-111, 113 and 114.
- 4.3.2 A small rectangular cropmark feature in the north-west corner of the site was believed to be a Neolithic mortuary enclosure, and was targeted by Trench 2. The eastern end of this feature was found, but only survived 50mm deep. No finds were recovered, and the dating of this feature remains uncertain.
- 4.3.3 In Trench 18, a NE-SW aligned ditch terminus or pit was excavated and contained 34 sherds of late Neolithic/early Bronze Age pottery. This ditch has a slight curve to the south, but was not visible and a cropmark, and its full extent is unknown.
- 4.3.4 Several ditches aligned north-south and NW-SE in Trenches 4, 39 and 41 contained late Iron Age/early Roman pottery, as did a curving ditch in Trench 41. Several features also contained pottery dating to the early Roman period including a NNE-SSW aligned ditch in Trench 40 and a NW-SE-aligned ditch in Trench 45.
- 4.3.5 The evaluation confirmed the existence of the linear features and discrete features identified as cropmarks (Place Services 2019). The geophysical survey carried out by the UXO engineers prior to the start of trenching also identified anomalies that corresponded to many of the linear cropmarks, and indicated continuations of a number of these. Plans showing the trenching in relation to the cropmarks, and to the cropmark and geophysical survey, are illustrated (Figs 3-6).
- 4.3.6 The cropmarks and geophysical anomalies indicated that there was a large rectilinear enclosure in the north-western part of the site and several subsidiary rectilinear enclosures to the south-east of the main complex. This was confirmed by the evaluation. Excavation of the ditches of the west, south and east sides of the large rectilinear enclosure produced pottery of middle to late Roman date, as did a probable trackway along its south edge. Further NW-SE ditches in the southern part of the site are undated, but may have been part of a Roman field system.
- 4.3.7 Two well-preserved large kilns were found, in Trenches 45 and 47, and several other ovens or kilns in Trenches 33, 39 and 46. The large pottery kilns were left unexcavated to preserve the remains for more detailed mitigation phase. The surface artefacts that were recovered indicate a late 2nd-3rd century date for the infill of these.
- 4.3.8 A mid-2nd century AD human cremation burial was found in Trench 15 and a possible cremation in Trench 45. This suggests that there are further cremation burials located within the site.
- 4.3.9 Several east-west and north-south post-medieval ditches were recorded in the eastern part of the site (Trenches 78, 79 and 80). These contained later post-medieval pottery and small finds.

## 4.4 Trench 1

- 4.4.1 Trench 1 contained a single ditch (103) and gully terminus (105) in the centre of the trench, both were aligned north-east to south-west (Fig. 7). The discrete cropmark features that were targeted were not revealed as archaeological features this trench.
- 4.4.2 Ditch 103 was 0.78m wide and 0.34m deep and contained a single fill (104) that yielded a worked flint of later prehistoric date (Fig. 8 Section 100).
- 4.4.3 Gully 105 terminated at its western end within the trench and was 0.49m wide and 0.28m deep. This also contained a single sterile fill (106).

## 4.5 Trench 2

- 4.5.1 The corner of a possible mortuary enclosure was recorded in the north-western corner of the trench. This comprised an east-west ditch (202, 208) and a NNW-SSE aligned ditch (204) that may, or may not, be related. Both ditches had shallow concave profiles with sandy gravelly fills (Fig. 8 Sections 200 and 203). The east-west ditch was 0.5-1.1m wide and 0.13-0.23m deep, terminating at the eastern end. Both interventions indicated that the ditch contained a single fill (203, 209). Ditch 204 was located to the north of the east-west ditch and was 0.5m wide and 0.1m deep containing a single sterile fill (205). Ditch 202/208 matches the recorded cropmark at this location. Ditch 204 did not match the location of the cropmark at this location, but it did match the alignment of the NNW-SSE cropmark just to the south. This suggests that ditches 202/208 constitute part of the southern corner of the enclosure and ditch 204 may represent the eastern end of the enclosure.
- 4.5.2 A small pit or posthole 206 was located at the western end of the trench and south of ditch 202/208. It was 0.35m in diameter and 0.08m deep filled with a single sterile fill (207).
- 4.5.3 Pit 212 was located at the western end of the trench and was 6m south of ditch 202/208. It was 1.1m wide and 0.12m deep with an irregular base and gently sloping sides and had one fill (213).
- 4.5.4 A large quarry pit (216) was machine excavated in the eastern side of the trench. The feature extended roughly 13.5 by 15m within the area of the trench. A cropmark corresponding to the location of the quarry extends much further to the east and is recorded in Trench 5. The quarry was excavated to a depth of 1m but the base was not reached. Four silty sandy fills were observed (217, 218, 219 and 220) within the feature and these were aligned at a roughly 45° angle, possibly indicating several tip lines (Fig. 8 Section 206).
- 4.5.5 A natural feature (214) was identified in the northern part of the trench. This contained a fill of orange/yellow silty sand (215).

## 4.6 Trench 3

- 4.6.1 Trench 3 contained two ditches (302, 304). Ditch 304 was at the north-western end of the trench, whilst ditch 302 was in the centre of the trench (Fig. 7).

- 4.6.2 Ditch 302 was 0.64m wide and 0.11m deep with a slightly concave profile and one fill (303).
- 4.6.3 Ditch 304 was aligned NE-SW and was broad and shallow being 2.22m wide and 0.32m deep. It contained two silty sandy fills with the basal fill (305) yielding two sherds of Roman pottery. The secondary fill (306) was 0.2m thick at the eastern side of the trench (Fig. 8 Section 301). This ditch matches the location of a cropmark which represents the north-western corner of a large rectilinear enclosure. The western side of the enclosure was present in Trenches 8, 11, 24 and 28.

## 4.7 Trench 4

- 4.7.1 Trench 4 contained three ditches (402, 406 and 408) and a single pit (404) (Fig. 9).
- 4.7.2 Ditch 402 was the most westerly of the featured observed. This ditch was aligned roughly north-south and was 0.69m wide and 0.15m deep (Fig. 10 Section 400). It had one silty sandy fill (403), which contained charcoal and 13 sherds of pottery dating to the late Iron Age/early Roman period.
- 4.7.3 Pit 404 was 0.86m in diameter and 0.2m deep with a concave profile (Fig. 10 Section 401) and one fill (405). This pit was cut on its eastern side by ditch 406. Ditch 406 was aligned NNW-SSE and was 0.94m wide and 0.26m deep and was filled with a single silty sandy deposit (407), which contained three sherds of late post-medieval pottery.
- 4.7.4 Ditch 408 was located within the eastern part of the trench and was aligned NE-SW. It was 1.08m wide and 0.38m deep with a V-shaped profile (Fig. 10 Section 402). It had one silty sandy fill (409).

## 4.8 Trench 5

- 4.8.1 Irregular feature 505/507 was recorded in plan and section (Figs 7 and 8 Section 500) and is part the large quarry that was encountered in Trench 2. The excavated single fill (506/508) did not produce any artefacts.
- 4.8.2 Ditch 503 was aligned WNW-ESE and it cut the southern edge of quarry pit 505/507. This ditch was 4m wide and was excavated to a depth of 0.7m but the base was not reached (Fig. 8 Section 500). The feature was filled with a single, sandy sterile silt deposit (504). The ditch matches the alignment and position of a cropmark.

## 4.9 Trench 6

- 4.9.1 Trench 6 contained a single ditch (604) and pit (602) (Figs 7 and 9).
- 4.9.2 Pit 602 was located in the southern part of the trench and was cut by ditch 604. The pit was 3.72m wide and at least 0.6m deep, the base not having been reached during excavation. The pit contained a single fill (603) (Fig 8 Section 600).
- 4.9.3 Ditch 604 was aligned east-west and was 2.1m wide and 0.36m deep containing two gravelly/silty sandy fills (605 and 606) (Fig. 8 Section 600). The upper fill (606) yielded a single sherd of Roman pottery and a fragment of medieval roof tile.

## 4.10 Trench 8

- 4.10.1 Trench 8 contained a single ditch (803) on a NW-SE alignment (Fig. 7). The ditch was 2m wide and 0.26m deep and was filled with a grey brown, silty sand (804) (Fig. 8 Section 800). The feature matched the alignment and approximate position of the cropmark defining the western edge of the large enclosure.

## 4.11 Trench 9

- 4.11.1 Trench 9 contained three ditches (903, 905 and 907) and a pit (910). Ditch 903 was located within the eastern part of the trench, whilst ditches 905, 907 and pit 910 intercut each other in the centre of the trench (Fig. 9).
- 4.11.2 Ditch 903 was aligned roughly north-south and was 1.04m wide and 0.33m deep containing a single sterile silty sandy fill (904).
- 4.11.3 Ditches 905, 907 and pit 910 match the alignment and approximate position of cropmarks recorded in this area. Ditches 905 and 907 had very shallow, profiles containing sterile silty sandy fills. A relationship between these ditches was not visible at the excavated section. Ditch 905 was aligned roughly NNW-SSE and was 0.46m wide and only 0.05m deep (Fig. 10 Sections 901 and 902) with one fill (911). Ditch 907 was aligned NE-SW and was 0.86m wide and 0.13m deep and had one fill (908) (Fig. 10 Section 902).
- 4.11.4 Pit 910 cut both 905 and 907. The feature was 1.41m wide and 0.37m deep and contained two sterile silty sand fills (906 and 909) (Fig. 10 Section 901).

## 4.12 Trench 11

- 4.12.1 Trench 11 contained one ditch (1103) and a posthole (1104) in the western end of the trench (Fig. 11).
- 4.12.2 Ditch 1103 was aligned NW-SE and was 2.6m wide and 0.54m deep with containing a silty sandy fill (1106) (Fig.12 Section 1101; Plate 1). The ditch matches the alignment and position of a cropmark defining the western edge of a large rectilinear enclosure. The feature was also observed in Trenches 8, 24 and 28.
- 4.12.3 Posthole 1104 was 0.44m in diameter and 0.48m deep and contained a single fill (1105) (Fig.12 Section 1100). This did not yield any artefactual material.

## 4.13 Trench 12

- 4.13.1 Trench 12 contained a possible pit/ditch terminus (1204), a modern plough scar (1205) and a large modern feature (1203). The trench also contained two small possible sub-oval natural features (1206 and 1207) that were 0.4-0.5m wide with diffuse edges and had silty sandy fills (1214, 1215 respectively) (Fig. 11).
- 4.13.2 Pit or ditch terminus 1204 was 0.32m wide and 0.1m deep with a steep side and a relatively flat base (Fig. 12 Section 1201). It continued into the eastern baulk. It contained one fill (1212), a dark brown coarse sandy deposit.

- 4.13.3 The large modern feature (1203) was aligned roughly NE-SW. The feature was 1.9m wide and was excavated to a depth of 0.9m. It contained four fills (1208, 1209, 1210 and 1211), all dark brown silty sand that appeared to be deliberate backfill. Fills 1208 and 1210 contained modern pottery, which was noted but not collected.
- 4.13.4 A plough scar (1205) was recorded truncating feature 1203. This may relate to the deep ploughing of this field for potato crop.

## 4.14 Trench 13

- 4.14.1 Trench 13 contained three ditches (1303/1307, 1305, 1311) and a possible shallow pit (1309) in the southern part of the trench (Fig. 11).
- 4.14.2 A possible natural feature (1313) was recorded to the south of the other features. This was sub-oval in plan, measuring 1.18m long, 0.70m wide and 0.12m deep. It contained a single, sterile silty sandy fill (1314).
- 4.14.3 Ditch 1305 was aligned NW-SE and was 0.7m wide and 0.08m deep (Fig. 12 Section 1301). It contained a single sterile silty sandy fill (1306).
- 4.14.4 Ditch 1303/1307 was aligned roughly NE-SW. This cut the fill of ditch 1305 on its eastern side and was in turn cut by ditch 1311 to the north. The ditch was 0.4m wide and 0.1-0.12m deep with a rounded base (Fig. 12 Sections 1300, 1301). It contained a brown silty sandy fill (1304, 1308). Fill 1304 contained one sherd of Roman pottery and flecks of charcoal.
- 4.14.5 Feature 1309, which may be a shallow pit or ditch terminus, was located north of ditch 1311. The feature was 1.3m wide and 0.16m deep and contained a single fill (1310) (Fig. 12 Section 1300).
- 4.14.6 Ditch 1311 was aligned roughly NNW-ESE and it truncated the fills of feature 1309 and ditch 1303/1307 and is therefore the latest in the sequence of ditches in Trench 13. This ditch was 1.2m wide and 0.16m deep with a flat base and moderately steep sides and one fill (1312) (Fig. 12 Section 1300).

## 4.15 Trench 15

- 4.15.1 Trench 15 contained one ditch (1513) and a cremation pit (1509) in the western part of the trench (Fig. 13).
- 4.15.2 Ditch 1513 was aligned NW-SE and was 1.2m wide and 0.5m deep with a V shaped profile (Fig. 14 Section 1500; Plate 3). It was filled with a single silty sandy fill, (1512), which contained 12 sherds of Roman pottery. The ditch matches the alignment and approximate position of a cropmark which may define an internal subdivision of the large rectangular enclosure.
- 4.15.3 Cremation pit 1509 was located 3m east of ditch 1513 and, if contemporary, would suggest the cremation was placed in one of the internal areas of the enclosure. This pit was oval in plan and was 1.3m long and 1m wide. The cremated human bone (1507) had been placed in a pottery jar (1508, sf 103). Analysis of the bone identified it as that of an adult male.

- 4.15.4 The pit also contained several ceramic grave goods, which had been placed around the cremation vessel: a grey ware dish (1503, sf 100), a samian dish (1504, sf 101), a white-slipped flagon (1506, sf 102), and a grey ware flask (1511, sf 104) (Plate 2). Together, the pottery can be dated to the mid-2nd century AD.

## 4.16 Trench 17

- 4.16.1 Trench 17 contained a pit (1703) and a possible furrow (1705) (Fig. 17).
- 4.16.2 Pit 1703 was oval in plan and measured 2m long, 0.66m wide and 0.22m deep. It had a concave base and gently sloping sides and contained a single sterile fill (1704) (Fig. 18 Section 1700).
- 4.16.3 Possible plough furrow 1705 was aligned NE-SW and was 0.98m wide and 0.19m deep with a concave profile and one fill (1706).

## 4.17 Trench 18

- 4.17.1 Trench 18 contained a roughly NE-SW aligned feature (1803), which may have been a ditch terminus or a pit as it appeared to terminate at the south-western end. The feature was 0.61m wide and 0.41m deep. It had a concave profile (Fig. 16 Section 1800; Plate 4) and contained a single fill 1802, from which 34 sherds of late Neolithic/early Bronze Age pottery were retrieved.
- 4.17.2 A test slot was excavated within sub-oval feature (1805) and it was interpreted as being natural. This faint soil mark corresponds with a recorded cropmark that was also targeted in Trench 19 where no features or soil marks were recorded. This suggests that the cropmark is a result of variation in the underlying geology rather than being a linear feature or, as another possibility, the 'ghost' remains of a plough-truncated feature.

## 4.18 Trench 21

- 4.18.1 Trench 21 contained one ditch terminus (2103), which terminated at the eastern end and was aligned roughly east-west (Fig. 17). The ditch was 0.78m wide and 0.14m deep with a sloped and stepped base and gently sloping sides (Fig. 18 Section 2100). It contained a single fill (2104).

## 4.19 Trench 24

- 4.19.1 Trench 24 contained two ditches, one of which remained unexcavated (Fig. 17).
- 4.19.2 Ditch 2402 was aligned NW-SE and may have been a continuation of the western edge of the enclosure observed as a cropmark. The ditch was 2m wide and 0.36m deep and contained a single sterile fill (2403) (Fig. 18 Section 2400).
- 4.19.3 Unexcavated ditch 2404 was 1.6m wide and was aligned roughly north-south. It matches the location of a cropmark, which continued southwards.

## 4.20 Trench 26

- 4.20.1 Trench 26 contained one ditch (2602), which was aligned ENE-WSW (Fig. 15). The ditch was 0.88m wide and 0.24m deep. It had a concave profile and a single fill (2603) (Fig. 16 Section 2600).

## 4.21 Trench 27

- 4.21.1 Trench 27 contained one ditch (2703) aligned roughly north-south (Fig. 17). The ditch was 1.32m wide and 0.22 deep and contained a single fill (2704) (Fig. 18 Section 2700). The ditch matches a cropmark recorded in this area and it is likely to be a continuation of a ditch (2404) seen in Trench 24. Other cropmarks recorded in the western end of the trench were not represented by archaeological features.

## 4.22 Trench 28

- 4.22.1 Trench 28 contained two ditches (2803, 2804) and a pit 2805 (Fig. 19). Ditch 2803 remained unexcavated but was recorded in plan.
- 4.22.2 Pit 2805 was sub-circular in plan and was 0.47m wide and 0.23m deep and contained a single fill (2807). The fill was cut on its northern edge by ditch 2804.
- 4.22.3 Ditch 2804 was aligned NE-SW. It was 0.5m wide and 0.09m deep and was filled with a single sterile fill (2806). It was truncated to the north-east by ditch 2803.
- 4.22.4 Ditch 2803 was 2.06m wide and was aligned NW-SE. This ditch corresponds with the western side of the large enclosure.

## 4.23 Trench 29

- 4.23.1 Trench 29 contained three ditches (2903, 2910 and one not numbered) and a pit (2905). The ditch within the southern end of the trench remained unexcavated (Fig. 19). The trench also contained a natural feature (2909) which was sample excavated to establish its origin.
- 4.23.2 Pit 2905 was 0.8m wide and 0.3m deep and was filled with a a single sterile fill (2906) (Fig. 20 Section 2901). It was cut by smaller pit 2907, which was 0.4m wide and 0.16m deep, which had a rounded base and a single fill (2908).
- 4.23.3 Ditches 2903 and 2910 were both aligned NE-SW and corresponded with two cropmarks. They were parallel to each other and 4.8m apart and may define a trackway. Ditch 2903 was 2.8m wide and 0.44m deep. It had moderately steep sides and an irregular base and one fill (2904). The ditch may have continued north-eastwards as ditch 3010 and formed the southern edge of the large rectilinear enclosure. Ditch 2910 was 1.6m wide and 0.44m deep and contained a single fill (2911) (Fig. 18 Section 2903). The feature may have continued north-eastwards as ditch 3008.

## 4.24 Trench 30

- 4.24.1 Trench 30 contained three ditches (3005, 3008, 3010) and a single pit (3003) (Fig. 19).

- 4.24.2 Pit 3003 was located at the southern end of the trench and was sub-circular in plan measuring 0.83m in diameter and 0.31m deep. This contained a single fill (3004) (Fig. 20 Section 3000).
- 4.24.3 Ditch terminus 3005 was aligned north-south and was 0.67m wide and 0.17m deep. The ditch was filled with two sterile deposits (lower fill 3006 and upper fill 3007).
- 4.24.4 Ditch 3008 was aligned NE-SW. It was 1.36m wide and 0.25m deep with a concave profile and one fill (3009).
- 4.24.5 Ditch 3010 was 0.94m wide and 0.54m deep and was filled with a single deposit (3011), that yielded a single worked flint (Fig. 20 Section 3003).
- 4.24.6 It is possible that ditches 3008 and 3010 formed part of a trackway. The gravel in ditch 3010 may be an indication that the trackway had a gravel surface, which may have eroded into the ditch.

## 4.25 Trench 32

- 4.25.1 Trench 32 contained a ditch (3203), which was aligned NW-SE (Fig. 21). The was 1.23m wide and 0.34m deep and contained a single fill (3204) (Fig. 22 Section 3200). The alignment of this ditch matches a cropmark to the south-east and may be a continuation of ditch 3503.

## 4.26 Trench 33

- 4.26.1 Trench 33 contained 12 pits, one of which was excavated (3303), and a possible kiln/oven (3311), which was not excavated (Fig. 21).
- 4.26.2 Pit 3303 was circular in plan and measured 0.41m in diameter and 0.16m in depth. It had a flat base and moderately steep sides (Fig. 22 Section 3300; Plate 5). This contained two fills. The primary fill (3304), comprised a sandy silt with occasional charcoal inclusions. This yielded two sherds of pottery dating to c1270-1350.
- 4.26.3 The unexcavated pits ranged in size from 0.28 to 2.36m in diameter (Fig.21 inset). The features had red/brown sandy silty fills. A surface find of a sherd of Roman pottery was found on pit 3308.
- 4.26.4 Two sub-square features (3307 and 3314) that were roughly 1m x 1m were also observed in plan but not excavated. Feature 3307 had a red halo and charcoal deposits around the edges. Feature 3314 contained red-brown clayey silt. These observations provide evidence of *in situ* burning, suggesting that the features may be ovens or kilns.

## 4.27 Trench 35

- 4.27.1 Trench 35 contained two undated ditches (3505, 3506), both aligned NW-SE and parallel to each other (Fig. 21).
- 4.27.2 Ditch 3503 was 0.76m wide and 0.3m deep. It contained a single fill (3504) (Fig. 22 Section 3500). Ditch 3505 was 0.51m wide and 0.13m deep and was filled with a single sterile deposit (3506).



## 4.28 Trench 36

- 4.28.1 Trench 36 contained three ditches (3603, 3605, 3607), a plough scar (3609) and an unexcavated feature (3611). All of these features were aligned roughly north-south (Fig. 21).
- 4.28.2 Ditch 3603 was the most easterly of the ditches. It was 0.55m wide and 0.08m deep with a shallow, concave profile with one fill (3604).
- 4.28.3 Plough scar 3609 was 0.34m wide and 0.1m deep with a shallow, concave profile and one fill (3610). Linear feature 3611 was 0.38m wide.
- 4.28.4 Ditch 3605 was 0.92m wide and 0.08m deep and had moderately sloped sides, a concave base and one fill (3606) (Fig. 22 Section 3601). The feature had been re-cut on its western side by ditch 3607. This measured 0.8m wide and 0.34m deep and had a steeply sloped eastern side and a more gently sloped western side, and a concave base (Fig. 22 Section 3601). It contained a single fill (3608), a dark blackish grey clayey sand.
- 4.28.5 Ditch 3605 and its recut 3607 appear to match the alignment of a field boundary shown on the 19th-century maps. It is therefore possible that this ditch is a north-south aligned post-medieval field boundary. It is also possible that ditch 3603 is a plough scar or small furrow, along with plough scar 3609 and unexcavated linear feature 3611. These features may all be contemporary with ditches 3605/3607, as they are on the same alignment. The modern field boundaries are aligned NE-SW in this area as are the alignment of the modern plough furrows (i.e. different to the north-south alignment).

## 4.29 Trench 37

- 4.29.1 Trench 37 contained one north-south aligned ditch (3703) which was unexcavated. The ditch was 1.4m wide in plan (Fig. 21). It is probable that this ditch is a continuation of the post-medieval boundary ditch (3605/3607) in Trench 36.

## 4.30 Trench 38

- 4.30.1 Trench 38 contained one north-south aligned furrow (3804) at the eastern end of the trench (Fig. 23). This furrow was 0.72m wide and 0.09m deep containing a single orange brown clayey fill (3803).

## 4.31 Trench 39

- 4.31.1 Trench 39 contained two small oven/hearth features (structures 3914, 3919), two north-south aligned ditches (3905, 3908), one NNW-SSE aligned ditch (3911) and three pits (3903, 3925, 3927) (Fig. 25).
- 4.31.2 Sub-oval pits 3925 and 3927 were located at the eastern end of the trench. Both had a similar profile of steep sides and a flat base. Pit 3927 measured 2.05m wide and 0.69m deep. It had one fill (3928), which contained three sherds of middle Iron Age pottery. It had been cut on its eastern edge by pit 3925 (Fig. 26 Section 3905), which measured 1.94m wide and 0.75m deep and contained a single fill (3926), from which 38 sherds of early Roman pottery and fragments of animal bone were recovered.

- 4.31.3 Ditch 3905 was aligned north-south. It measured 1.49m wide and 0.45m deep with a V-shaped profile (Fig. 26 Section 3901). It contained two fills, (3906 and 3907).
- 4.31.4 Ditch 3908 was aligned north-south and was 0.8m wide and 0.3m deep (Fig. 26 Section 3902). This was filled with two deposits (3909 and 3910) from which a single sherd of Roman pottery was recovered along with a single worked flint.
- 4.31.5 Ditch 3911 was on a NNW-SSE alignment. This ditch was 2.45m wide and 0.43m deep (Fig. 26 Section 3902). The upper fill (3912) of this ditch yielded ten sherds of pottery dating to the late Iron Age/early Roman period.
- 4.31.6 Pit 3903 was located at the western end of the trench and was sub-oval in plan. The pit was 1.38m wide and 0.12m deep (Fig. 26 Section 3903). It had one sandy silty fill (3904), which produced five sherds of Roman pottery.
- 4.31.7 Possible oven Group 3919 was constructed at the western end of the trench. Its cut (3920) was sub-oval in plan and measured 1.42m long, 0.52m wide and 0.22m deep. It had a concave base and steep sides (Fig. 26 Section 3903). The feature was surrounded by an orange layer of burnt and scorched clayey sand. The primary fill (3921), a yellowish-brown, silty sand, was 0.04m thick. This was overlain by fill 3922, a 0.12m-thick layer grey silt that was rich in charcoal. This layer may represent *in situ* burning and perhaps the final firing of oven 3919. This layer was overlain by a grey brown silty clay (3923), which was 0.08m thick and contained five sherds of Roman pottery, and an upper silty clay layer (3924) that was 0.05m thick. Upper fills 3923 and 3924 are likely to represent the infilling of the oven after it went out of use.
- 4.31.8 A second possible oven, Group 3914, truncated this upper fill of 3919 on its northern side. Its cut (3915) was sub-oval in plan and measured 0.78m long and 0.47m wide. It had a concave profile and moderately steep sides (Fig. 26 Section 3903; Plate 6). The lining of this oven was visible and may have partially reused the burnt lining of oven 3919. The primary fill of oven 3914 was a yellow brown sandy silt (3916). This was overlain by a layer of *in situ* burning (3917), a dark grey silt with frequent charcoal inclusions that was 0.06m thick. Upper fill 3918 was a brown grey silty clay, 0.11m thick, which produced two sherds of mid-Roman pottery. Layer 3902 was 0.05m thick and was a grey brown silty clay that contained one sherd of Roman pottery.

## 4.32 Trench 40

- 4.32.1 Trench 40 contained three ditches that were excavated (4005, 4007, 4009) and two unexcavated ditches (4011, 4013) (Fig. 25). Ditches 4011 and 4013 were both aligned NW-SE and matched the position of two linear features recorded as cropmarks. Surface finds from 4011 included five sherds of Roman pottery.
- 4.32.2 A possible colluvial layer (4012) was identified in this trench which contained one sherd of Roman pottery dating to AD 200-410 and a small fragment of a disc-type quern or millstone.

- 4.32.3 Ditches 4005, 4007 and 4009 were all aligned NNE-SSW and were intercutting. Ditch 4005 was the latest in the sequence and cut both ditches 4007 and 4009 (Fig. 26 Section 4000). These ditches match the alignment and approximate position of a linear feature recorded as a cropmark and may represent a long-standing internal subdivision of the main Roman enclosure. Ditch 4005 contained a large quantity of pottery of mid- to late Iron Age date, which may have derived from an earlier feature.
- 4.32.4 Ditch 4009, the northernmost feature in the sequence, was 0.82m wide and 0.4m thick. It had a moderately steep side and one fill (4010). Ditch 4007, the southernmost feature, was 1.62m wide and 0.51m deep and had a gently sloped side and one fill (4008). The fill contained 62 sherds of early Roman pottery (AD 43-70).
- 4.32.5 Ditch 4005 cut both ditches 4007 and 4009. The ditch was 2.94m wide and at least 0.54m deep with a concave profile. The base of the ditch was not reached, as the feature was extended below the permitted depth of excavation (1m below modern ground level). The lower-most excavated fill, 4006, a grey clayey silt, was up to 0.54m thick. It yielded 341 sherds of pottery dated mostly to AD 150-250, and also a substantial amount of residual mid- to late Iron Age pottery. Other finds included residual Neolithic to early Bronze Age worked flint, a fragment of tegula, other pieces of ceramic building material, a burnt fragment of a greensand rotary quern, and a manuport, a perfectly spherical natural flint nodule that may have been curated. Upper fills 4003 and 4004 were grey clayey silt and grey silty clay respectively that were up to 0.1m thick. Fill 4003 contained 108 sherds of pottery dating to AD 240-410 and four pieces of Roman tile.

### 4.33 Trench 41

- 4.33.1 Trench 41 contained four linear ditches (4106, 4111, 4114, 4116), a curvilinear ditch (4109) and two pits (4102, 4104) (Fig. 27).
- 4.33.2 Pits 4102 and 4104 were both circular in plan and were located within the western end of the trench. Pit 4102 was 0.61m in diameter and 0.22m deep with one fill (4103). Pit 4101 was 0.52m in diameter and 0.13m deep with an uneven base and one fill (4104).
- 4.33.3 Ditch 4111 was aligned NE-SW and was 1.41m wide and 0.58m deep with e (Fig. 28 Section 4104). It had two fills (4112 and 4113). The upper fill (4113) yielded a single sherd of Roman pottery.
- 4.33.4 Ditch 4114 was located 1.5m south-east of ditch 4111 and was also aligned NE-SW. The feature was 0.65m wide and 0.17m deep and was filled with a single deposit (4115) that yielded one sherd of mid- to late Iron Age pottery.
- 4.33.5 Curvilinear ditch 4109 was located in the centre of the trench. It was 0.94m wide and 0.3m deep (Fig. 28 Section 4103). The feature had one fill (4110), which contained a sherd of pottery dating to the late Iron Age/early Roman period. The ditch may be part of an annular or penannular ditch, at least 7.2m in diameter, perhaps representing a roundhouse or a small circular enclosure. It may be contemporary with ditches 4111, 4114 and 4116, which are located to either side.

- 4.33.6 Ditch 4116 was located towards the eastern side of the trench and was aligned NW-SE. It was 1.5m wide and 0.36m deep and had steep sides and a rounded base (Fig. 28 Section 4106). It contained a single fill (4117).
- 4.33.7 Ditch 4106 was located at the south-eastern end of the trench and was aligned NW-SE. It was 1.02m wide and 0.37m deep (Fig. 28 Section 4102). Basal fill 4107 was 0.18m thick and contained two sherds of late Iron Age/early Roman pottery. Upper fill 4108 was a grey brown silty sand 0.18m thick, from which charcoal, a sherd of burnt pottery dating to the late Iron Age/early Roman period, and animal bone were collected.

## 4.34 Trench 42

- 4.34.1 Trench 42 contained a number of features which extended outside the boundary of the trench. This included a possible curving ditch alignment (4203), possible ditches (4208, 4210, 4212), a large pit (4205/4214) and a small pit 4216 (Fig. 27).
- 4.34.2 Ditches 4208 and 4212 were located in the southern end of the trench. Ditch 4208 was aligned NW-SE. It was 1.98m wide and 0.11m deep and contained a grey silty sandy fill with lenses of gravel (4209). Twelve sherds of late Bronze Age/early Iron Age pottery were recovered. The fill of the ditch was cut by 4212 to the south. The ditch had a moderately steep northern edge and was at least 0.23m deep. A silty sandy fill (4213) was recorded.
- 4.34.3 Curvilinear ditch 4203 extended some 9.2m along the length of the trench. It was at least 0.97m wide and 0.18m deep before it disappeared under the western baulk (Fig. 28 Section 4200). The feature contained one observable fill (4204), from which nine sherds of Roman pottery were retrieved.
- 4.34.4 Ditch 4210 was located at the northern end of the trench and was aligned north-south, but disappeared under the western baulk. It was at least 0.8m wide and 0.28m deep with gently sloping sides and a flat base. It contained a single fill (4211), which yielded three sherds of Roman pottery and a worked flint.
- 4.34.5 A large pit feature with two straight sides was located in the centre of the trench. This extended was at least 2m wide. Two interventions (4205 in the northern part of the feature and 4214 on the southern side) indicated that the feature was more than 0.5m deep on the northern edge and 0.32m deep on the southern edge (Fig. 28 Sections 4201, 4204; Plate 7). The lowest excavated fill (4206) contained 55 sherds of mid-2nd/early 3rd century AD pottery and a Roman coin dating to the 1st or 2nd century. The upper fill (4207), which was distinctly darker than the lower fill, contained 77 sherds of pottery dating to AD 150-200. The fill on the southern side (4215), an orange brown silty sand, contained nine sherds of Roman pottery dating to AD 150-250. It is possible that this large feature is a pit containing domestic occupation debris of middle Roman date.
- 4.34.6 The upper fill of the pit was cut on its southern side by a small sub-circular pit, 4216 (Fig 28 Section 4204). This was 0.5m in diameter and 0.26m deep with steep sides, a concave base and one fill (4217).

## 4.35 Trench 43

- 4.35.1 Trench 43 contained four pits and a ditch. One of the pits (4308) was excavated, but the remaining features (4303, 4304, 4305 and 4307) were not investigated (Fig. 25).
- 4.35.2 Pit 4308 was 1.68m wide and 0.18m deep and continued into the northern bulk of the trench. It contained one fill (4306) from which a worked flint was recovered.
- 4.35.3 Two sherds of Roman pottery were found on the surface of unexcavated ditch 4303.
- 4.35.4 The ploughsoil (4300) overlay a colluvial layer (4301). which sealed a grey brown silty sandy subsoil (4309). This in turn overlay the natural geology (4302). The colluvial layer was 0.4m thick and comprised a grey brown silty sand with occasional stone inclusions. Some 87 sherds of Roman pottery were recovered from this deposit.

## 4.36 Trench 45

- 4.36.1 Trench 45 contained a pottery kiln (group 4503), three ditches (4507, 4514 and 4517) and a possible cremation or burnt deposit (4510) (Fig. 27).
- 4.36.2 Ditch 4507 was aligned NW-SE. It cut earlier possible cremation pit Group 4510. The ditch was 2.24m wide and at least 0.4m deep, with shallow to moderately steep sides. The base was not reached. The lowest observed fill (4509) was a brown grey sandy silt with clay lenses, which contained 190 sherds of pottery dating to AD 230-300. The upper fill (4508) was a brown sandy silty deposit, which contained a 191 sherds of pottery dating to AD 350-410, along with a Roman tegula, animal bone, residual worked flint and a copper alloy object (sf 4).
- 4.36.3 Ditch 4517 was aligned NW-SE and was 2.38m wide and at least 0.55m deep. It had one fill (4518), a grey brown silty sand which contained animal bone and three sherds of pottery dating to the late Iron Age/early Roman period. The ditch was recut on its western side by ditch 4514 (Fig. 28 Section 4502; Plate 9). Ditch 4514 was 2.56m wide and at least 0.52m deep. It had moderately steep sides and contained two silty sandy fills. The lower fill (4515) contained 75 sherds of pottery dating to AD 230-300, along with Roman brick and a degraded fragment of a rotary quern.
- 4.36.4 Group 4510 was a possible cremation pit or burnt deposit. It comprised pit 4511, fill 4512 and surrounding deposit 4513. The pit was sub circular in plan and was 0.35m wide and 0.06m deep (Fig. 28 Section 4501). Its fill was a brown grey sandy silt with concentrations of charcoal and fired clay, tiny fragments of burnt bone and five undated worked flints. The bone was analysed but as there was only 0.2g of bone in the sample it could not be positively identified as human. It may instead represent animal remains within a burnt deposit. Another deposit (4513) was recorded just outside pit 4511. This was a yellow brown sandy silt, 0.4m wide and 0.05m thick.

- 4.36.5 Group 4503 comprised a kiln structure in the western part of the trench that appeared to be remarkably well preserved, apart from being cut by later ditch 4506 (Plate 8). The feature was not unexcavated as part of this evaluation to ensure the preservation of the remains for future, more detailed, investigation. The kiln structure and deposits were cleaned and recorded in detail. Structure 4505 represents the firing chamber of the kiln. Its outline was clearly defined by an outer ring of black soil and inner ring of yellowish soil. Much of the chamber was filled by red-brown soil. The latest pottery from the feature dated to the second half of the 4th century AD. The stoking-hole and flue were represented by a bottle-shaped area of dark brown sandy silt with frequent charcoal (4504). Pottery (330 sherds) dating to AD 180-200 and a 1st-century bow brooch (sf 2) were retrieved from the surface of this area.
- 4.36.6 The infill of the kiln chamber was truncated by an unexcavated ditch (4506). This was on a NW-SE alignment across the centre of the kiln chamber and measured 0.8m wide. Some 20 sherds of pottery dating to AD 140-250 were collected from the surface of the feature, although these are likely to be residual material derived from the kiln deposits.

## 4.37 Trench 46

- 4.37.1 Trench 46 contained two ditches (4603, 4614), two pits (4606, 4608) and a layer (4612/4621). It also contained a possible oven 4619 and an area of possible rake-out (4620) in the western part of the trench (Fig. 27).
- 4.37.2 Ditch 4614 was the mostly easterly feature in the trench. It was aligned NE-SW and measured 1.78m wide and at least 0.48m deep. It had moderately steep sides, but its base was not reached (Fig. 28 Section 4603). The earliest observable fill was 4617, a brown silty sand which contained fired clay. This was overlain by an orange brown sandy silt (4616) with charcoal and burnt material. The fill also contained fired clay, possibly derived from an oven structure. Upper fill 4615 was an orange sandy silt containing a medieval roof tile and burnt clay. The tile may be an intrusive artefact.
- 4.37.3 Ditch 4603, 3m west of 4614, was also on a NE-SW alignment. It was 1.94m wide and 0.34m deep with moderately steep sides and a concave base (Fig. 28 Section 4600). Basal fill was a sandy silt (4604) which contained charcoal and pottery. The upper fill (4605) was a grey brown clayey silt which contained 45 sherds of pottery dating to AD 140-250, as well as a fragment of a rotary quern.
- 4.37.4 A layer spread (4612, 4621) was identified in the western part of the trench. It was 5.7m long and extended beyond the limits of the trench. Two interventions made in this spread indicated that the feature filled a shallow depression into the natural and was 0.11-0.14m deep. It contained two further depressions or fills (4613, 4622) of orange grey silt, both of which included abundant fired clay. This material may include raked-out debris from an oven or kiln, possibly 4608 or 4619. The layer was cut by pit 4608 (Plate 11).

- 4.37.5 Pit 4608 was sub-circular in plan and measured 0.88m in diameter and 0.31m deep with a sharply-defined rounded profile (Plate 11). This pit was infilled with three fills. The basal fill (4611) was a 0.09m-thick *in situ* burnt layer containing charcoal and fired clay. Middle fill 4610 was a yellow brown silty layer, 0.24m thick, which contained occasional charcoal and fired clay. Upper fill 4609 was a 0.15m thick yellow brown silty layer which contained a charcoal-rich lens and burnt stone. A dark brown grey sandy silt deposit also overlay the northern layer 4621 and this was 0.22m thick.
- 4.37.6 Pit 4606 was sub-circular in plan. It was 0.62m wide and 0.09m deep and had concave sides and a rounded base (Plate 10). The sides of the pit were scorched. Its fill (4607) was a blue-grey clayey silt, which contained abundant charcoal fragments and five sherds of pottery and a hobnail dating to the Roman period.
- 4.37.7 Feature 4619 was not excavated, although it was recorded in plan. It was sub-square in plan and measured 1m wide. A halo of black and red scorched clay was visible around the edge of this feature. An area of possible rake-out (4620) was also recorded. The feature may be a kiln or oven and possibly related to pit 4606.

## 4.38 Trench 47

- 4.38.1 Trench 47 contained a large pottery kiln (Group 4704), a single pit (4709), and two ditches (4702 and 4707) (Fig. 31).
- 4.38.2 Ditch 4702, located within the northern end of the trench, matched the NW-SE alignment and position of a linear cropmark. The ditch was 0.94m wide and 0.22m deep and was filled with a single deposit (4703) that yielded 21 sherds of late Roman pottery dating from AD 250-410 (Fig. 32 Section 4700). This ditch appears to be part of a smaller rectilinear enclosure on the same alignment as the main enclosure to the north-west.
- 4.38.3 Ditch 4707 was aligned roughly east-west and measured 0.69m wide with a rounded, shallow profile (Fig. 32 Section 4701). The feature contained a single fill (4708), a clayey sand which yielded a large pottery assemblage comprising 593 sherds dating to AD 200-300.
- 4.38.4 Pit 4709 was just north of ditch 4707. It was sub-circular in plan, with a concave base and moderately steep sides, and measured 1.26m in diameter and 0.29m deep (Plate 12). The feature had two fills. Basal fill 4710 was 0.20m thick and contained 207 pottery sherds dating to AD 200-410. The fill of this pit was very similar to the base of kiln 4704. Upper fill 4711 was a yellow brown sandy clay that was only 0.08m thick. This appeared to be redeposited natural and was perhaps a levelling deposit.

- 4.38.5 Group 4704 was a kiln in the southern part of the trench. The feature was at least 5.2m in overall length and extended beyond the limit of the trench. The firing chamber (4705) was circular in plan and c 1.7m in diameter. It was filled with a dark grey clayey sand, which was surrounded by a ring of red, brown-yellow and dark grey, clayey sand representing the various scorched zones of the firing chamber structure. Pottery collected from the surface deposits comprised 54 sherds dating to AD 120-410. An area of dark grey, clayey sand to the south (4706) represents the infilled rake out area and stoking-hole. A large amount of pottery – some 199 sherds dating to AD 100-410 – was collected from the surface of this deposit. A small intervention was excavated into the edge of this fill to establish feature depths. This showed that the rake out pit edge was stepped and in excess of 0.5m deep (Fig. 32 Section 4704). Its fill (4713) contained 21 sherds of pottery dating to AD 250-410.

### **4.39 Trench 48**

- 4.39.1 Trench 48 contained two ditches and a possible pit or ditch terminus (Fig. 31). All three features had moderately steep sides and a concave base.
- 4.39.2 Ditch 4805, in the north-western part of the trench, was aligned NE-SW and was 1.12m wide and 0.36m deep with one fill (4806) (Fig. 32 Section 4801).
- 4.39.3 Ditch 4803, in the central part of the trench, was aligned ENE-WSW and was 0.8m wide and 0.22m deep with moderately steep sides and one fill (4804). Both ditches 4803 and 4805 correspond to cropmark features with 4805 likely to be a subdivision of the small enclosure defined in Trenches 47, 49 and 61 and identified by cropmarks.
- 4.39.4 Ditch terminus or pit 4807 was aligned roughly NNW-SSE. It was 0.84m wide and 0.28m deep and contained one fill (4808).

### **4.40 Trench 49**

- 4.40.1 Trench 49 contained three ditches (4900, 4901, 4904). All three matched the alignment and approximate position of linear features recorded as cropmarks (Fig. 31). Ditches 4900 and 4901 form the south-eastern corner of the small rectilinear enclosure also investigated in Trenches 47 and 61.
- 4.40.2 Ditch 4900 was aligned NE-SW and was 0.45m wide and 0.16m deep with moderately steep sides and a concave base. It had one fill (4902).
- 4.40.3 Ditch 4901 was aligned NW-SE and was 0.8m wide and 0.32m deep with moderately steep sides and a concave base and one fill (4903).
- 4.40.4 Ditch 4904 was aligned east-west and was 0.47m wide and 0.15m deep (Fig. 32 Section 4902). It had one fill (4905). This ditch is on a similar alignment to ditch 4803 to the north and may represent part or successive phases of a single enclosure or boundary arrangement.

### **4.41 Trench 50**

- 4.41.1 Trench 50 contained multiple NNW-SSE aligned linear ditches (5003, 5005, 5007, 5009, 5011) (Fig. 33). These match the alignment of a field boundary and a trackway shown on later 19th century OS maps.



- 4.41.2 Ditch 5003 was located in the western part of the trench and was 1.18m wide and 0.52m deep. The ditch had moderately steep sides and a concave base with one fill (5004) (Fig. 34 Section 5000). It was recut on its eastern side by ditch 5005. This was 1.12m wide and 0.28m deep with gently sloping sides and a rounded base (Fig. 34 Section 5000). It had one fill (5006), which contained charcoal, three sherds of Roman pottery and a small sherd of post-medieval glass. The Roman pottery is likely to be residual in this case.
- 4.41.3 Ditch 5007 to the east was 1.6m wide and 0.5m deep with moderately steep sides and a concave base. It had one fill (5008).
- 4.41.4 Ditch 5011, to the east of 5007, was 1.22m wide and 0.42m deep with moderately steep sides and a concave base (Fig. 34 Section 5002). It had one grey brown silty sandy fill with frequent gravel (5012). The ditch was recut on its eastern side by ditch 5009, which was 2m wide and 0.52m deep with moderately steep sides and a flat base (Fig. 34 Section 5002). It had one sandy silty fill (5010).

## 4.42 Trench 55

- 4.42.1 Trench 55 contained three ditches (5507, 5505 and 5503) (Fig. 35).
- 4.42.2 Ditch 5007 was located at the southern end of the trench and was on a NW-SE alignment. It was 1.34m wide and 0.2m deep (Fig. 36 Section 5502). It had one grey brown silty sandy fill (5508). This ditch matched the alignment and position of a linear cropmark feature.
- 4.42.3 Ditch terminus 5505 was aligned roughly north-south and was 0.8m wide and 0.25m deep. It had moderately steep sides, a concave base and one fill (5506), which contained post-medieval glass.
- 4.42.4 Ditch 5503 was on a NW-SE alignment and was 0.45m wide and 0.24m deep with shallow sides and a concave base. It had one fill (5504).

## 4.43 Trench 56

- 4.43.1 Trench 56 contained three ditches (5603, 5605 and 5607). All three were on a NE-SW alignment and matched a linear cropmark at this location. The ditches may be a continuation of the southern part of the main enclosure ditch, which was also observed in Trenches 29 and 30 (Fig. 3).
- 4.43.2 Ditch 5605 was the central of the three ditches and was 0.36m wide and 0.15m deep containing a single fill (5606) (Fig. 30 Section 5600). Ditch 5605 was recut on its northern side by ditch 5603, which was 0.66m wide and 0.21m deep with moderately steep sides, a gentle sloping base and one fill (5604) (Fig. 30 Section 5600).
- 4.43.3 Ditch 5607 was 0.71m wide and 0.12m deep with gently sloping sides and a concave base (Fig. 30 Section 5600). It had one fill (5608).

## 4.44 Trench 57

- 4.44.1 Trench 57 contained four ditches (5703, 5710, 5707, 5708), and a gully (5705). This trench was extended to allow for excavation of ditch 5707 (Fig. 29).

- 4.44.2 Ditch 5703 was on a NE-SW alignment and was 1.7m wide and 0.37m deep with concave sides and a flat/rounded base (Fig.30 Section 5700). It had one sandy silty fill (5704).
- 4.44.3 Ditch 5710 just south of ditch 5703 was aligned NNE-SSW and was 4.67m wide and more than 0.5m deep. It had steep sides, but the base was not fully reached (Fig. 30 Section 5703). The ditch contained at least three fills. The deepest fill on its north side (5711) was a silty sand, 0.4m deep, with pebble inclusions. Fills 5712 and 5713 were of a similar composition and contained gravel inclusions.
- 4.44.4 Ditch 5708, south of ditch 5710, was aligned NNE-SSW. It was 1.48m wide and 0.32m deep with shallow sides and a concave to flat base (Fig. 30 Section 5702). It had one fill (5709).
- 4.44.5 Gully 5705 was on a NE-SW alignment. It was 0.54m wide and 0.12m deep and had moderately steep sides and a flat base. It contained a single fill (5706). Ditches 5705 and 5708 continue the alignment of the enclosure cropmark and features investigated in Trench 56 to the immediate south-west.
- 4.44.6 Ditch 5707 was located in the southern part of the trench and was on a NW-SE alignment. This ditch was 2.9m wide and 0.26m deep with gently sloping sides and a flat base. It had a single silty sandy fill (5714), which yielded 18 sherds of pottery dating to AD 120-410 and fragments of tegula and imbrex tile.

## 4.45 Trench 58

- 4.45.1 Trench 58 contained two ditches (5802, 5806) and a tree-throw hole (5804). Both ditches were aligned NW-SE and corresponded to the alignment and approximate position of a linear cropmark feature. This appears to define a small rectilinear enclosure off the south-eastern corner of the large cropmark enclosure (Figs 5 and 29).
- 4.45.2 Ditch 5806 was 1.12m wide and 0.44m deep (Fig. 30 Section 5800). It had one fill (5807), which contained burnt flint. This ditch was recut on its western side by ditch 5802. This was 1.64m wide and 0.28m deep and contained a single fill (5803).
- 4.45.3 Tree-throw hole 5804 cut ditch 5802. It was 0.34m wide and 0.24m deep and had an irregular profile and shape in plan. It had a silty sandy fill (5805).

## 4.46 Trench 60

- 4.46.1 Trench 60 contained a small ditch (6003) aligned NE-SW. It was 0.56m wide and 0.20m deep and had a V-shaped profile. The feature contained a single brown red silty clay fill (6004).

## 4.47 Trench 61

- 4.47.1 Trench 61 contained two ditches (6103, 6108) and a pit (6104). The ditches matched the alignment and position of linear cropmarks recorded at this location, although ditch 6103 appears to continue further south-east than the recorded cropmark (Fig. 31).

- 4.47.2 Ditch 6108 was located in the southern part of the trench and was aligned NW-SE. It was 0.52m wide and 0.18m deep and had a U-shaped profile. The feature contained one fill (6109).
- 4.47.3 Ditch 6103 was aligned NW-SE and was 0.82m wide and 0.17 deep. It had shallow sides, a concave base and a single fill (6105) (Fig. 32 Section 6101). The ditch was cut by pit 6104. This was circular in plan and had steep sides and a concave base. It measured 0.57m in diameter and 0.25m wide (Fig. 32 Section 6101).

#### **4.48 Trench 70**

- 4.48.1 Trench 70 contained a possible ditch terminus (7003) (Fig. 39). The feature was aligned NW-SE and matched the approximate position of a cropmark. The ditch was 0.96m wide and 0.33m deep and was U-shaped in profile (Fig. 40 Section 7000; Plate 14). It had two fills, basal fill (7005) was 0.25m thick and contained a large amount of burnt flint and stone. Upper fill (7004) was 0.13m thick. Neither deposit produced any dateable artefacts.

#### **4.49 Trenches 74, 79 and 80**

- 4.49.1 Trenches 74, 79 and 80 all contained post-medieval ditches which match the position and alignment of field boundaries shown on late 19th century OS maps (Fig. 41). These ditches (7403, 7906 and 8003) form a single ESE-WSW alignment and were 1.3-1.9m wide and 0.5-0.65m deep with matching profiles (Fig. 42 Sections 7400 and 7900). One of these ditches was not excavated (7906). These ditches contained a number of late post-medieval finds. Ditch 7403 contained animal bone and a late 19th or early 20th century glass bottle base. Ditch 8003 contained a clay pipe bowl dating to c1840-1910 and CBM dating to the 16th-19th century.
- 4.49.2 Ditch 7903 was on a north-south alignment and was perpendicular and contemporary with the east-west ditches. The feature was 1.68m wide and 0.62m deep with steep sides and a rounded base (Plate 16). It had two grey brown silty sandy fills. The basal fill (7904) was 0.26m thick. Upper fill 7905 was 0.38m thick and contained a piece of mid-18th century glass.

#### **4.50 Trench 76**

- 4.50.1 Trench 76 contained an ENE-WSW aligned ditch (7602), a tree-throw hole (7604) and a modern feature (7606), which was unexcavated (Fig. 37).
- 4.50.2 Ditch 7602 was 1.62m wide and 0.4m deep. It had a U-shaped profile and contained one fill (Fig. 38 Section 7600). The ditch matched the position and alignment of an ENE-WSW-aligned field boundary shown on a later 19th century map.
- 4.50.3 The feature was cut by a large tree-throw hole (7604), which was 1.56m wide and continued southwards beyond the trench area. The tree-throw hole was at least 0.5m deep but the base was not reached. The fill (7605) was a brown grey silt.
- 4.50.4 Modern feature (7606) was located just north of ditch 7602 and was crescent-shaped in plan. It contained modern glass.

## 4.51 Trench 78

- 4.51.1 Trench 78 contained two ditches (7802, 7805), a tree-throw hole (7807) and a modern feature (7804) at the eastern end, which was not excavated (Fig. 39).
- 4.51.2 Ditch 7802 was aligned ENE-WSW and was 1.32m wide and 0.36m deep and was filled with a single sterile sandy silty fill (7803). The ditch matches the approximate location of a field boundary on the later 19th century maps and may be post-medieval in date and be a continuation of the ditch recorded in Trenches 74, 79 and 80 to the east (Fig. 2).
- 4.51.3 Ditch 7805 was located at the western end of the trench and was aligned roughly north-south. It was 1.32m wide and 0.36m deep, with moderately steep sides and a rounded base (Fig. 40 Section 7801; Plate 15). It had one fill (7806), a grey brown silty sand which contained one sherd of late Bronze Age pottery and fired clay. The ditch was cut by a large tree-throw hole (7807), which was 3.16m wide and 0.24m deep with an irregular side and base. This may have been part of a tree-lined field boundary, as an ENE-WSW field boundary was located in this vicinity in the later 19th century.

## 4.52 Trench 92

- 4.52.1 Trench 92 contained two ditches (9203, 9205) (Fig. 23). Ditch 9203, the most westerly of the two, was 2.04m wide and at least 0.5m deep, although its base was not reached (Fig. 24 Section 9200). It contained two fills that did not produce any dating evidence.
- 4.52.2 Ditch 9205 was 0.82m wide and 0.31m deep with moderately sloping sides and a rounded, concave base with one sterile fill (9206).

## 4.53 Trench 98

- 4.53.1 Trench 98 contained one ditch (9807) on an NNE-SSW alignment (Fig. 45). It matches the position and alignment of a field boundary shown on later 19th century OS maps (Fig.2). The feature was 1.26m wide and 0.55m deep, with moderately sloping sides and a rounded, concave base. It had one silty sandy fill (9808), which contained a sherd of Roman pottery, which may be residual.

## 4.54 Trench 107

- 4.54.1 Trench 107 contained a single NNW-SSE aligned ditch at the southern end of the trench (Fig. 23). The ditch (10704) was 0.86m wide and 0.2m deep, with steep sides and a flat base that contained one fill (10704) (Fig. 24 Section 10700).

## 4.55 Trenches 109, 110 and 111

- 4.55.1 Combined, Trenches 109, 110 and 111 contained a small concentration of at least four ditches aligned NW-SE and arranged parallel to each other. These shared similar dimensions, trench-like profiles and fill sequences, although artefactual assemblages and dating evidence was lacking apart from a few worked flints.

- 4.55.2 Trench 109 contained two ditches (10903, 10905). Both were aligned NW-SE (Fig. 43). Ditch 10903 was the most northerly of the two and was 1.66m wide and 0.26m deep, with shallow, steep sides and a flat base (Fig. 44 Section 10900). It contained one fill (10904).
- 4.55.3 Ditch 10905 was also 1.66m wide and 0.26m deep, with steep sides and a flat base. It had one fill (10906).
- 4.55.4 Trench 110 contained two ditches aligned NW-SE (11003, 11005), although the westernmost feature appeared to terminate, but then continue as another ditch, although this may be due to truncation (Fig. 43).
- 4.55.5 Ditch 11003 was 1.55m wide and 0.24m deep and had moderately steep sides and a concave base (Fig. 44 Section 11000). It contained one fill (11004), a sandy silt.
- 4.55.6 Ditch 11005 was 1.55m wide and 0.19m deep, with moderately steep sides and a concave base. It had one sandy silty fill (11006). This feature was recorded as terminating before resuming as another ditch (11007), but it is more likely that the ditch was truncated and is a continuation of a single ditch.
- 4.55.7 Trench 111 contained two ditches (11103 and 11105) which were both on a NW-SE alignment, matching the alignment of the ditches in Trench 109 (Fig. 43).
- 4.55.8 Ditch 11103 was 1.7m wide and 0.66m deep, with steep sides and a flat base (Fig. 44 Section 11100). It had one sandy silty fill (11104), which contained three worked flints.
- 4.55.9 Ditch 11105 was also 1.58m wide and 0.39m deep with steep sides and a flattish base. It had one sandy silty fill (11106), which contained five worked flints.

## **4.56 Trench 113**

- 4.56.1 Trench 113 contained two irregular amorphous features: 11303, which is thought to be a natural depression in the gravel, which subsequently infilled with silt, and 11305, which is interpreted as a tree-throw hole. It measured 1.36m wide and 0.38m deep and contained redeposited natural.

## **4.57 Trench 114**

- 4.57.1 Trench 114 contained two NNE-SSW aligned ditches (11416, 11408) and four pits (11403, 11406, 11411, 11414) (Fig. 45).
- 4.57.2 Ditch 11408 was 1.32m wide and 0.49m deep, with steep sloping sides and a concave base. It contained two fills. The lower fill (11410) was 0.16m thick, while the upper fill (11409) was 0.33m thick.

- 4.57.3 Ditch 11416 slightly curved and so may be part of a larger curvilinear ditch or enclosure. The ditch profile was well defined being 1.68m wide and 0.81m deep (Fig. 46 Section 11403). The ditch contained six silty sandy fills; most of them contained pottery or worked flint. Fill 11417 was the basal fill and was overlain by fills 11418 and 11419. Fill 11419 contained three sherds of late Bronze Age to early Iron Age pottery, 131g of burnt flint and five worked flints. Fills 11420 and 11421 were towards the top of the sequence, while fill 11422 was uppermost. Fills 11418, 11420, 11421 and 11422 also contained worked flint.
- 4.57.4 Sub-circular pits 11403 and 11406 were located at the western end of the trench. Pit 11406 was 1.18m in diameter and 0.2m deep, with shallow sides and a concave base. It had one silty sandy fill (11407). The pit had been cut on its southern side by pit 11403, which was 0.52m in diameter and 0.22m deep. It had moderately steep sides and a flattish base and contained two fills. Basal fill 11404 was 0.2m thick. Upper fill 11405 was 0.04m thick and contained charcoal, burnt stone and worked.
- 4.57.5 Pits 11411 and 11414 were located just west of ditch 11416 in the centre of the trench. Pit 11411 was 0.46m wide and 0.13m deep, with steep sides and a concave base (Fig. 46 Section 11402). It contained two fills that did not produce any dating evidence (basal fill 11412 and upper fill 11413).
- 4.57.6 Pit 11414 was 0.3m south of pit 11411 and was sub-circular in plan and 0.46m in diameter and was 0.13m deep with one fill (11415) (Fig. 46 Section 11402).

## 4.58 Finds summary

- 4.58.1 **Late prehistoric pottery.** One feature, ditch 1803, produced 34 sherds of pottery of late Neolithic/early Bronze Age date. Most of these belong to a single vessel, an all-over corded Beaker. Four features – ditch 4208, ditch 7805, ditch 11104 and ditch 11416 – contained pottery of late Bronze Age/early Iron Age date. Two features – pit 3927 and ditch 4114 – contained pottery of middle to late Iron Age date.
- 4.58.2 **Roman pottery.** Some 3321 sherds of pottery, weighing 28.1kg, were recovered from the evaluation. The assemblage spans the Roman period, but the emphasis is on the middle to late Roman periods (*c* AD 120-410).
- 4.58.3 Much of the pottery is likely to have been manufactured locally, with a proportion of it deriving from the kilns identified on the site, although no kiln-damaged pottery was identified to confirm which fabrics were products of the kilns. Generally, the forms encountered in the assemblage are consistent with those manufactured in the region, with most vessels being paralleled in typologies established for Mucking (Lucy and Evans 2016) and Chelmsford (Going 1987).
- 4.58.4 Overall, the assemblage was in fragmentary condition. The mean sherd weight (weight divided by sherd count) is 8.46g, which is characteristic of an assemblage of relatively small fragments. This figure is consistent across the periods and site areas and points to multiple episodes of redeposition, perhaps away from the settlement core.

- 4.58.5 **Ceramic building material.** A small quantity of ceramic building material (CBM) amounting to 17 fragments weighing 1968g was recovered from Trenches 6, 40, 45, 46, 57 and 80. The assemblage consists of fairly small fragments, all less than 110mm in size, generally in fresh or lightly abraded condition with a slightly below average mean fragment weight of 116g. The assemblage contained material of Roman, medieval and post-medieval date.
- 4.58.6 The Roman tile is focused on Trenches 40, 45, and 57 suggesting activity or settlement in the area. However, the tile is not indicative of any form of masonry structure in the vicinity of the evaluation. The assemblage is typical of that found on lower status rural settlements where material has been obtained from higher status settlements for reuse.
- 4.58.7 Medieval to post-medieval flat roof tile was found in Trenches 6, 46 and 80.
- 4.58.8 **Fired clay.** A modest quantity of fired clay amounting to 248 fragments weighing 3437g was recovered, the majority found in Trenches 40-42 and 45-7, whilst small amounts were found in Trenches 4, 18, 78 and 111. The majority of the fired clay has been phased to late Iron Age-Roman with the main emphasis on middle-late Roman. The general character of the assemblage is consistent with this. A small quantity may be prehistoric (fills 1802 and 7806).
- 4.58.9 The bulk of the fired clay was found in features of late Iron Age-Roman date, the majority occurring in middle-late Roman contexts. These included two kilns, 4503 and 4712, in Trenches 45 and 47 and an oven, 4619 in Trench 46, which may be the source of much of the fired clay in these trenches. Portable kiln furniture in the form of firebars and plates was identified in Trenches 40, 45 and 47.
- 4.58.10 **Worked flint.** The evaluation recorded a moderate flint assemblage of 70 pieces of struck flint and 215 burnt unworked fragments weighing 821g. The assemblage was flake based with a low blade index. The assemblage included a number of flake cores and tools indicative of late Neolithic and Bronze Age flint working. The tool forms included a wide range of forms with scrapers (3), denticulates (2), a microdenticulate, a piercer, a retouched flake and an end truncation. The last two tools were probably early prehistoric in date, while two well-made scrapers were very probably later Neolithic or early Bronze Age in date. The density of flintwork recovered was low and many originated as residual finds in later feature. However, several features contained reasonable assemblages of between 5 and 14 pieces with the largest assemblage originating from five separate fills in later prehistoric ditch 11416. This may well represent a contemporary assemblage.
- 4.58.11 **Metals.** There were ten metal finds, comprising seven iron objects and 3 copper alloy objects. The iron objects included three probable nails (contexts 1210, 4207 and 4504), a single hobnail (context 4607), and an irregular fragment of thick plate (context 1210). There was also a possible blade fragment (context 4615) and a length of bar or strip with an apparent irregular expansion, partly obscured by corrosion products (context 7905). None of the iron objects can be dated, with the exception of the possible Roman hobnail.

- 4.58.12 The three copper alloy finds comprise a simple bow brooch with spring of 1st-century date (context 4504), a Roman copper alloy coin that could be of 1st or 2nd century date (context 4206).
- 4.58.13 **Glass.** Three pieces of vessel glass were recovered from contexts 5006, 7404 and 7905. All were dated to the post-medieval period.
- 4.58.14 **Clay pipe.** A single piece of clay pipe bowl weighing 12g was recovered from context 8004 and was spot-dated to c 1840-1910.
- 4.58.15 **Stone.** A total of nine pieces of stone were retained and submitted for analysis. The stone included three fragments of unworked stone (4700, 4708, 5714). In addition there is a single unworked spherical flint nodule (4006). These are naturally formed, but it may represent a manuport.
- 4.58.16 Five fragments from four rotary querns were recovered. Two tiny fragments of Mayen lava were found in context 4515 (5g) and this lava quern would have been imported from the continent. Fragments from two separate Millstone Grit querns were found in contexts 4605 and 4012 (387 and 235g respectively). A larger fragment of Greensand quern was found in context 4006 (568g). The querns are very likely to be Roman in date, although lava and Millstone Grit querns were also used during the Saxon and medieval periods and millstones of these lithologies continued in use into the modern period.
- 4.58.17 **Slag and coal.** A single small piece of non-magnetic slag, was found in context 4616. One small fragment of coal was found in context 4706 and two fragments in context 8005.

## 4.59 Environmental and osteological summary

- 4.59.1 **Human bone.** Two deposits containing burnt human bone (1507 and 4512) were recovered.
- 4.59.2 Deposit 1507 was contained within a pottery jar 1508 (SF 103) and had been buried in pit 1509, along with four ceramic grave goods. Deposit 1507 was positively identified as human. The individual was adult, based on the presence of a fragment of mandible with tooth sockets for the second and third permanent molars. Sex was estimated as possible male, based on fragments of the occipital bone, including a relatively prominent nuchal crest.
- 4.59.3 Burnt bone deposit 4512 was unurned and was found within pit 4511 in Trench 45. The burnt bone was within a mid-brownish grey sandy silt matrix. It was thought at the time of excavation that 4512 represented a cremation burial, but osteological analysis could not confirm whether bone was human or animal.
- 4.59.4 **Animal bone.** A total of 167 animal bone specimens were recovered from the site. Preservation on the site was poor, most likely due to acid soils.
- 4.59.5 Domestic cattle was the most common species on the site, present in every phase. Also present is pig, caprine (sheep and/or goat) and horse. Domestic cattle and sheep are the mainstay of the rural economy in Iron Age and Roman Britain, with pig and horse also common, and so this site fits that pattern.



- 4.59.6 **Charred plant remains.** Twenty-five samples were taken from the evaluation. The samples confirm that the features contained charred remains that are generally in good condition, and so the area can be considered to have good potential for the recovery of this material. Identification of charred material indicates that diverse assemblages are present on site. The samples come from a range of features across the site, though twelve are from cremation spits and these produced minimal quantities of material.
- 4.59.7 Multiple samples were taken from features of Roman date. Samples 3 and 4 (Trench 39, cuts 3915 and 3920) are both associated with ovens and offer potential to explore fuel usage. Samples 9 to 20 which are from cremation spits (1509) produced little in the way of charred material.
- 4.59.8 Sample 25 was from fill 4706 of cut 4712 which was dated with pottery to middle to late Roman period. This sample produced a diverse assemblage of wheat, barley, oat, legumes and a fragment of hazelnut. Several weed species common to disturbed or cultivated ground were present and are considered to be crop contaminants.
- 4.59.9 A single sample was taken from fill 3304 of pit 3303 which was dated as medieval. Wheat, Goosefoots and rachis fragments were identified.
- 4.59.10 Several samples were taken from features with no spot dating available. Sample 6, from fill 1105 of posthole 1104, contained a large quantity of charcoal.
- 4.59.11 Several features may be suitable for radiocarbon dating including Sample 6 (fill 1105 of posthole 1104), Sample 8 from fill 4611 of pit 4608 and Sample 23 from fill 4512 of possible cremation 4511.

## 5 Discussion

---

### 5.1 Reliability of field investigation

- 5.1.1 The archaeological features were reasonably well defined against the underlying Boyn Hill Gravel, although the site conditions were challenging at times due to the persistent wet weather and standing water in some trenches.
- 5.1.2 There was a correlation in a number of cases between the cropmarks recorded by aerial survey and the linear features encountered in the evaluation. These cropmarks may have been 1-2m either side of the features they represented but the alignment and approximate position showed a strong correlation (Figs. 3-6). This was particularly true of the large rectilinear enclosure on a NW-SE alignment. The western side of this enclosure was identified in Trenches 3, 8, 11, 24 and 28. The eastern side was identified in Trench 45 and possibly in Trench 40 with two unexcavated ditches. The southern part of the enclosure and a possible trackway ditch was identified in Trenches 29, 30 and 56. Internal ditches that served as subdivisions within the main enclosure were recorded in Trenches 9, 15, 39 and 40. Additional NW-SE aligned enclosures were identified in Trenches 47, 48, 49, 58 and 61. Many of the features were relatively shallow suggesting that where the linear cropmarks were not found in the trenches they may have been truncated by ploughing as the site is in use as arable fields with deep cultivation methods utilized in recent years for potato crops.
- 5.1.3 The pit-like cropmark features identified in the northern, western and southern part of the site were not encountered during the excavation, with the exception of the large quarry in Trenches 2 and 5. It is possible that the majority of the discrete features recorded by the cropmarks were natural features or ground moisture retention variations due to the underlying geological deposits. Alternatively, they may have been truncated by modern ploughing, although this is thought to be less likely as one would expect some to remain as deep features.
- 5.1.4 The northern part of the site contained several previously unidentified areas of archaeological features in Trenches 42, 46 and 57 and several of these contained late Bronze Age (4208) or Roman pottery (4203, 4210, 4214, 4606, 4608, 5750). The southern part of the site also contained a number of previously unidentified north-south, NW-SE or NNE-SSW aligned ditches in Trenches 37, 38, 107, 109, 110, 111 and 114.
- 5.1.5 The cause of the high and moderate magnetometer noise in the eastern part of the site is unclear as the majority of trenches in this area did not find any archaeological features. It is possible there could be a geological reason for this, since this area forms part of a slope of a dry valley.

## 5.2 Interpretation

- 5.2.1 **Neolithic/early Bronze Age.** Thirty-four sherds of late Neolithic/early Bronze Age pottery were found in ditch terminus or pit 1803. This feature was not clear in plan and may be part of a larger arrangement. The pottery included large sherds from an all-over corded Beaker. This vessel could indicate the presence of funerary or domestic activity of this period in the vicinity. While the evaluation uncovered no evidence of ring-ditches or barrows, such evidence is by no means unknown in the region, Beaker burials being known, for example, at Mucking (Evans *et al.* 2015) and Orsett 'Cock' (Milton 1987) and within the LTC corridor to the east (Land Parcels 4 and 5). Domestic activity of this period tends to be limited to clusters of pits and so it is possible that more pits of this date may exist around Trench 18.
- 5.2.2 **Late Bronze Age/early Iron Age.** Three features were dated to the late Bronze Age/early Iron Age and these were located in Trenches 42, 78 and 114. This includes north-south aligned ditch 7805, NW-SE aligned ditch 4208 and possible curvilinear ditch 11416.
- 5.2.3 North-south aligned ditch 7805 was tentatively dated to the late Bronze Age based on a single sherd of late Bronze Age pottery, but it is possible that the material is residual.
- 5.2.4 Ditch 4208, aligned NW-SE, contained 12 sherds of late Bronze Age to early Iron Age pottery.
- 5.2.5 Ditch 11416 had a slight curve to it and so may be part of a larger curvilinear ditch or enclosure. The ditch was quite substantial, being 1.68m wide and 0.81m deep with six fills. One fill contained three sherds of late Bronze Age to early Iron Age pottery and one worked flint of later prehistoric date, which may be contemporary with the pottery.
- 5.2.6 Such late Bronze Age/early Iron Age evidence forms part of a wider landscape of contemporaneous activity. One of the most notable sites is the group of circular ditches, the North and South Rings at Mucking, constructed in the late Bronze Age. Interpretation is open to question, but they may have served a social and economic role as a gathering place and a place of trade and exchange (Evans *et al.* 2015). Activity closer to the current site was recorded as part of the wider scheme at LTC1 Masons Corner (Oxford Archaeology 2020), where a posthole, a pit and a NE-SW aligned ditch were recorded. Settlement of this date is known at Baker Street, some c 600m north-west of the site, where pits, a gully and eight postholes which may have formed an oval building were uncovered (Wilkinson 1988, 15-16).
- 5.2.7 **Middle Iron Age.** Pit 3927 and ditch 4114 were tentatively dated by pottery to the middle Iron Age and the middle/late Iron Age, respectively. However, the profile of pit 3927 was very similar to that of early Roman pit 3925, and it is possible that the few sherds of pottery that date 3927 are residual.
- 5.2.8 **Late Iron Age/early Roman.** A number of features were dated to the late Iron Age/early Roman period.

- 5.2.9 Ditch 402 was north-south aligned and contained 13 sherds of late Iron Age/early Roman pottery. It is possible that this was an outlying ditch related to the more intensive area of late Iron Age/early Roman activity located c 150m east.
- 5.2.10 A cluster of ditches in the northern part of the site (3911, 4106 and 4517) contained late Iron Age/early Roman pottery. One sherd of pottery was also found in curvilinear ditch 4109 and it is possible that this feature may have formed part of a ring-ditch or small enclosure. In addition, a large amount of residual late Iron Age/early Roman pottery was found in ditch 4005. This suggests that this middle Roman ditch had wholly truncated an earlier feature.
- 5.2.11 Pit 3925 and ditch 4007 are of more certain early Roman date. Ditch 4007 is one of several intercutting ditches and may be the earliest ditch in the sequence. It contained 62 sherds of pottery dated AD 43-70. Pottery from subsequent recuts suggest that the enclosure continued in some form into the middle Roman period.
- 5.2.12 The evidence suggests that there was a late Iron Age/early Roman settlement located within the northern part of the site, perhaps focused in the area of Trenches 39, 40, 41 and 45. Ditches here formed part of an early Roman enclosure that appears to have been incorporated into a much larger one, which was laid out on a slightly different alignment.
- 5.2.13 **Middle/late Roman.** The majority of the middle to late Roman dated Roman features were recorded in Trenches 15, 39, 40, 42, 45, 46, 47 and 57. A number of other features could only be dated as Roman and these were located in Trenches 3, 13, 15, 33, 43 and 98.
- 5.2.14 The main rectilinear enclosure ditch aligned NW-SE was dated by the pottery in ditch 304 as Roman. Dating evidence was not found for the main enclosure ditches in Trenches 8, 11, 24, 28, 29 and 30. As indicated above, the best evidence for the date of the enclosure came from a NNE-SSW-aligned ditch in Trench 40. The earliest ditch in the sequence (4007) may have silted up before AD 70. It was recut at least twice with ditches 4005 and 4009, which were on the same alignment. Ditch 4005 was the latest in the sequence and its lower fill contained some 340 sherds of pottery dating to AD 150-250, while the upper fill contained 108 sherds of pottery dating to AD 240-410.
- 5.2.15 Most of the mid/late Roman features were located within the northern part of the site (Trenches 39, 40, 41 and 45), suggesting that the focus of settlement from this period lay in this area. Roman tile was found in Trenches 40, 45 and 57, although this is likely to have been reused, having been taken from buildings located elsewhere. Typically, in rural sites, tile and brick was reused in structures such as ovens, hearths and kilns.
- 5.2.16 A cremation burial was found in Trench 15 (pit 1509) along with a number of grave goods dated to the mid-2nd century AD. The location of this cremation within a subsidiary enclosure raises the possibility that the enclosure had a funerary function and that more burials may be found.

- 5.2.17 Two pottery kilns (Groups 4503 and 4704) were recorded. These both remained unexcavated to avoid unnecessary damage to the remains outside of controlled open area excavation. Surface finds recovered from the cleaning of both structures included a large quantity of Roman pottery. This suggests that the kilns were in use during the later 2nd century or later. The latest pottery from this area dated to AD 350-410, suggesting that Roman activity continued here until at least the mid-4th century.
- 5.2.18 **Summary.** The Roman settlement identified by this evaluation may have been a multi-purpose rural/industrial site with a diverse range of activities. This included pottery production, domestic activity, and a possible cremation cemetery. Several of the enclosures may have also been large livestock pens. The majority of the animal bone was found in Trenches 39, 40, 41, 42 and 45 in the area previously identified as domestic. Butchery may have been taking place in the vicinity of Trench 40. A domestic cattle radius from context 4008 was chopped obliquely, which could imply industrial scale butchery. The environmental evidence also suggests that arable farming was taking place nearby. Crops included wheat, barley, oats and legumes, possibly vetch which was suitable for both human consumption and animal fodder. Five fragments from four rotary querns were recovered in Trenches 40, 45 and 46 suggesting that crop processing was also taking place in this part of the site.
- 5.2.19 The north-south/NW-SE aligned ditches in the southern part of the site were undated, but they may have been part of a late Iron Age/Roman field system associated with the settlement.
- 5.2.20 The evidence obtained by the aerial survey and archaeological evaluation has helped define a large rectilinear enclosure that was subdivided into smaller rectilinear enclosures. These may have been used for different activities – domestic, industrial and funerary activity, as well as livestock management or other forms of farming. In plan and perhaps in organisation, the enclosure system closely resembles that of Roman Mucking (Lucy and Evans 2016).
- 5.2.21 **Medieval.** There were few medieval finds on the site. The encountered artefacts included pieces of CBM in ditch 606 and 4615 and late 13th-mid-14th-century pottery in pit 3303.
- 5.2.22 Pit 3303 was located close to eleven other pits and a possible kiln/oven (3311), which remain unexcavated. It is possible that all these features are medieval in date, given their location just south of Hornsby Lane road. The pits may be associated with a medieval roadside farmstead. Alternatively, they may be Roman in date and the medieval pottery may be intrusive.
- 5.2.23 **Post-medieval.** Five ditches (406, 5505, 7403, 7903 and 8003) were dated as post-medieval from the finds that were recovered from them. One additional ditch (7906) was dated as post-medieval, as it matched the alignment of two other ditches (7403, 8003) and a field boundary on late 19th century OS maps (Fig. 2).

- 5.2.24 Ditch 406 was aligned NNW-SSE and contained three sherds of 18th-19th century pottery. This field boundary is not shown on the Orsett tithe map of 1840 (not illustrated) (Essex Record Office D/CT 264/1) or the later 19th-century OS maps. This suggests that was a field boundary that went out of use before the tithe map was drawn in c 1840.
- 5.2.25 Ditch terminus 5505 was aligned roughly north-south and its fill contained post-medieval glass. This possible field boundary is located c 14m west of an extant field boundary on a similar alignment. It perhaps indicates a field boundary which went out of use and was replaced with one further east.
- 5.2.26 Ditches 7403, 7602, 7906 and 8003 were all aligned ESE-WSW and ditches 7403 and 8003 contained later post-medieval finds. Their alignment and position matched the position and alignment of field boundaries shown on later 19th century OS maps (Fig. 2). This field boundary was part of a series of larger arable post-medieval fields that were located south of Heath Place. This particular field boundary is shown on the OS map of 1897 (Fig.2) and subsequent OS maps (not illustrated) until the 1970s when it was removed to create a larger field.
- 5.2.27 Ditch 7903 was on a north-south alignment and contained mid-18th century glass. It also matched the position of a north-south footpath/trackway shown on the later 19th century maps and was probably used as ditch associated with this footpath/trackway (Fig. 2). The trackway led from Heath Place southwards to join the Brentwood Road. As with ditches 7403, 7906 and 8003 this trackway/footpath appears to have been removed by the 1970s. It is possible that undated NNE-SSW aligned ditches 9807 and 11408 may have formed part of the same trackway.
- 5.2.28 **Undated.** Many ditches and pits on the site remained undated. In the north-western corner of the site this included two NE-SW aligned linear features in Trench 1. In Trench 2 the putative mortuary enclosure did not contain any dating evidence to either confirm or disprove the interpretation as a prehistoric enclosure. The large quarry in Trenches 2 and 5 did not contain any dating evidence although it was cut by a later WNW-ESE ditch. In Trenches 12 and 13 there were several undated ditches. It is possible that the ENE-WSW aligned ditch shown on the cropmarks at this location may be a post-medieval field boundary shown on the Orsett tithe map of 1840 (not illustrated) (Essex Record Office D/CT 264/1). The northern-western part of the site contained a possible north-south trackway which may have been encountered in Trenches 9 (ditch 903, 905) and may have continued southwards as ditch 2703. This possible trackway did not contain any dating evidence although ditch 905 in Trench 9 was located by later pit 910.

- 5.2.29 The south-western part of the site contained three NW-SE aligned undated ditches in Trenches 32 and 35 (3203, 3503, 3505). Ditch 3503 matched the alignment and position of a NW-SE aligned cropmark at this location and this ditch may have continued as ditch 3203 to the north-west. Ditch 3505 was parallel and 4.5m south-west of ditch 3503. It is possible that these ditches were part of a trackway which continued south-eastwards and was plotted as part of the aerial survey. This trackway may have terminated at a cello-shaped cropmark enclosure which was discussed and shown in the WSI (OA, WSI, fig.5). (Place Services: sites 22 and 32). This enclosure is located c 200m south of the site and may date from the later Iron Age or Roman period. This small enclosure may have been contemporary with the large Roman enclosure on the site or may have been superseded by it.
- 5.2.30 This NW-SE aligned trackway in Trenches 32 and 35 may be contemporary with the roughly north-south and NW-SE aligned undated ditches that were recorded in the southern part of the site. These ditches do match the general alignment of the Roman main enclosure which is on a NW-SE and a NE-SW alignment. The NW-SE ditch 11103 contained three worked flints of earlier prehistoric date but these are very likely residual.
- 5.2.31 **Geological features.** Several features recorded in Trenches 2, 12, 13 and 113 were found to be natural. The features were uneven in plan and section and contained sterile silty sandy fills. They may have been caused by natural depressions in the gravel which had then silted up.
- 5.2.32 **Natural features.** Two tree-throws, 5804 and 7604, were recorded. The latter truncated an ENE-WSW aligned ditch (7602), which is shown as a field boundary on later 19th and early 20th century OS mapping (Fig.2). This tree throw may have grown out of a post-medieval ditch which had silted up.

### 5.3 Evaluation objectives and results

- 5.3.1 This evaluation established the presence of archaeological remains and investigated their character through stratigraphic, artefactual and environmental evidence. The evaluation also ground-truthed the cropmark evidence as identified by the 2019 aerial survey (Place Services 2019). In addition, the evaluation investigated the apparently blank areas where no cropmarks had been identified.
- 5.3.2 The archaeological evaluation was conducted within the general research parameters and objectives defined by the revised East of England Research Framework (Medlycott 2011), and took account of the aims and objectives of the Greater Thames Estuary Historic Environment Research Framework.
- 5.3.3 In terms of specific objectives, the evaluation identified physical remains of a possible mortuary enclosure in the north-west corner of the site, although the interpretation of this feature could not be proven. The ditches associated with this feature had only survived up to 0.23m deep and contained no dating evidence.

- 5.3.4 The evaluation identified a large quarry pit in the north-western corner of the site, although this was undated. In terms of the other discrete features that were shown as cropmarks, the majority of these were not identified within the trenches and are likely to have been variations in the natural geology. It is also possible that the aerial survey had identified pits that were shallow, with subsequent ploughing removing or truncating them severely.
- 5.3.5 Roman activity was identified across the site. This includes a late Iron Age/early Roman settlement with domestic activity in the area of Trenches 39-45. The large main enclosure with associated trackway was possibly created in the early to mid-Roman period and was then recut several times. It is likely that settlement activity continued in the eastern part of this enclosure (Trenches 39-45) during the middle to later Roman period. The south-eastern part of the enclosure contained several pottery kilns. The settlement appears to have been involved in arable and pastoral farming, crop processing and possibly butchery of animals on an industrial scale. The enclosure may have continued in use until the later Roman period.
- 5.3.6 The NW-SE aligned field boundaries and trackway in the southern part of the site were undated, but may be contemporary with the main enclosure.
- 5.3.7 A later post-medieval ENE-WSW field boundary was identified in the eastern part of the site, along with a north-south post-medieval trackway. These features are likely to be associated with Heath Place farm to the east of Hornsby Lane.
- 5.3.8 Several trenches in the central and northern part of the site encountered a colluvial layer, which contained Roman pottery. These trenches are located in the area of the dry valley and may explain the density of archaeology here, with the colluvial layer acting as a protective layer preserving this part of the site from truncation.



## Appendix A Trench Tables

Trench 1							
General description					Orientation		NW-SE
Trench consisted of ploughsoil and subsoil overlying the natural geology.  Trench 1 contained a single ditch (103) and gully terminus (105) in the centre of the trench, both were aligned north-east to south-west.					Length (m)		40
					Width (m)		2
					Avg. depth (m)		0.39
Context No.	Type	Fill of	Width (m)	Depth (m)	Description	Finds	Date
100	Layer			0.39	Ploughsoil. Dark grey brown, silty clay		
101	Layer			0.15	Subsoil. Light grey brown, silty sand with frequent gravel inclusions		
102	Layer				Natural. Light orangey yellow, silty sand and gravel		
103	Cut		0.78	0.34	Ditch		
104	Fill	103	0.78	0.34	Primary Fill. Light brown grey, silty sand	Worked flint	Later prehistoric?
105	Cut		0.49	0.28	Ditch		
106	Fill	105	0.49	0.28	Primary Fill. Mid brown grey, silty clay-sand		
Trench 2							
General description					Orientation		E-W
Consists of ploughsoil overlying natural geology.  Trench 2 contained one corner of a small enclosure (202, 204, 208), a pit (212) a small pit (206) and a large quarry pit (216). A natural feature (214) was also identified in the northern part of the trench and this contained a fill of orange/yellow silty sand (215).					Length (m)		24
					Width (m)		14
					Avg. depth (m)		0.37
Context No.	Type	Fill of	Width (m)	Depth (m)	Description	Finds	Date

200	Layer			0.37	Ploughsoil. Dark grey brown, silty clay		
201	Layer				Natural. Light orangey yellow, silty sand		
202	Cut		1.1	0.13	Ditch		
203	Fill	202	1.1	0.13	Primary Fill. Mid grey brown sandy gravel		
204	Cut		0.5	0.1	Ditch		
205	Fill	204	0.5	0.1	Primary Fill. Light grey brown sandy gravel		
206	Cut		0.35	0.08	Posthole		
207	Fill	206	0.35	0.08	Primary Fill. Light grey brown sandy gravel		
208	Cut		0.37	0.23	Ditch		
209	Fill	208	0.37	0.23	Primary Fill. Light grey brown sandy gravel		
210	Void		0.34	0.19			
211	Void		0.34	0.19			
212	Cut		1.1	0.12	Pit		
213	Fill	212	1.1	0.12	Primary Fill. Light greyish brown sandy gravel		
214	Cut		0.67	0.18	Natural Feature		
215	Fill	214	0.67	0.18	Primary Fill. Light orangey yellow, silty sand		
216	Cut		9	0.7	Quarry. Possible gravel extraction pit. Machine excavated. Full dimensions unknown/unexcavated		
217	Fill	216	1	0.7	Secondary Fill. Mid yellow brown, silty sand. Machined until 1m		
218	Fill	216	2.4	0.66	Secondary Fill. Mid grey brown silty sand. Machine excavated to 1m.		
219	Fill	216	1.74	0.74	Secondary Fill. Dark grey brown silty clay. Machine excavated to 1m		

220	Fill	216	1.2	0.44	Secondary Fill. Mid yellow brown silty sand. Machine excavated to 1m		
<b>Trench 3</b>							
General description					Orientation	NW-SE	
Trench revealed two ditches. Consisted of ploughsoil overlying the natural geology.  Trench 3 contained two ditches (302, 304). Ditch 304 was at the north-western end of the trench whilst ditch 302 was in the centre of the trench.					Length (m)	30	
					Width (m)	2	
					Avg. depth (m)	0.31	
Context No.	Type	Fill Of	Width (m)	Depth (m)	Description	Finds	Date
300	Layer			0.31	Ploughsoil. Dark grey brown, silty clay		
301	Layer				Natural. Mid orangey/red yellow, silty sand with frequent gravel		
302	Cut		0.64	0.11	Ditch		
303	Fill	302	0.64	0.11	Primary Fill. Mid grey brown, silty sand		
304	Cut		2.22	0.32	Ditch		
305	Fill	304	2.22	0.32	Primary Fill. Mid yellow brown, silty sand	Pottery (2)	Roman
306	Fill	304	1.2	0.2	Secondary Fill. Mid grey brown, silty sand		
<b>Trench 4</b>							
General description					Orientation	NW-SE	
Consisted of ploughsoil overlying natural the geology.  Trench 4 contained three ditches (402, 406 and 408) and a single pit (404). This ditch also contained two natural features (410, 411) that were both filled with a brown grey silty sand.					Length (m)	30	
					Width (m)	2	

						Avg. depth (m)	0.32
Context No.	Type	Fill Of	Width (m)	Depth (m)	Description	Finds	Date
400	Layer			0.32	Ploughsoil. Dark grey brown, silty clay		
401	Layer				Natural. Mid orangey and red yellow, silty sand with gravel patches		
402	Cut		0.69	0.15	Ditch		
403	Fill	402	0.64	0.15	Primary Fill. Mid grey brown, silty sand	Pottery (13)	late IA/ER
404	Cut		0.86	0.2	Pit		
405	Fill	404	0.86	0.2	Primary Fill. Light grey brown, silty sand		
406	Cut		0.94	0.26	Ditch		
407	Fill	406	0.86	0.2	Primary Fill. Mid grey brown, silty sand	Pottery (3)	C18th-19th
408	Cut		1.08	0.38	Ditch		
409	Fill	408	1.08	0.38	Primary Fill. Mid grey brown, silty sand		
410	Cut				Natural Feature. Light brown grey, silty sand		
411	Cut				Natural Feature. Light grey brown, silty sand		
<b>Trench 5</b>							
General description						Orientation	N-S
Consisted of ploughsoil and subsoil overlying the natural geology.  Trench 5 contained a single ditch (503) cutting through a quarry pit (505, 507).						Length (m)	30
						Width (m)	2
						Avg. depth (m)	0.75
Context No.	Type	Fill Of	Width (m)	Depth (m)	Description	Finds	Date

500	Layer			0.35	Ploughsoil. Dark grey brown, silty clay		
501	Layer			0.4	Subsoil. Mid brown, silty sand		
502	Layer				Natural. Mid orangey/red yellow, silty sand without gravel patches		
503	Cut		4	0.7	Ditch		
504	Fill	503		0.7	Secondary Fill. Dark grey brown sandy silt, frequent small sub-rounded stone inclusions		
505	Cut				Pit. Irregular feature shown as crop marks. Likely used for gravel extraction. Cut by 503		
506	Fill	505			Secondary Fill. Dark grey brown silty sand, frequent sub-rounded stone inclusions		
507	Cut				Ditch. Irregular feature shown as crop marks. Likely gravel extraction.		
508	Fill	507			Secondary Fill. Dark grey brown silty sand, frequent small sub-rounded stone inclusions		

### Trench 6

General description	Orientation	N-S
Consisted of ploughsoil overlying the natural geology. Trench 6 contained one ditch (604) and one pit (602).	Length (m)	30
	Width (m)	2
	Avg. depth (m)	0.35

Context No.	Type	Fill Of	Width (m)	Depth (m)	Description	Finds	Date
600	Layer			0.35	Ploughsoil. Dark grey brown, silty clay		
601	Layer				Natural. Mid orangey and red yellow, silty sand with frequent gravel		
602	Cut		3.72	0.6	Pit. Not bottomed		

603	Fill	602	3.72	0.6	Primary Fill. Mid yellowish brown, silty sand. Not bottomed		
604	Cut		2.1	0.36	Ditch		
605	Fill	604	2.02	0.1	Primary Fill. Dark brownish grey, gravel sand		
606	Fill	604	2.1	0.26	Secondary Fill. Mid greyish brown, silty sand.	Pottery, CBM	Roman (res), Medieval
<b>Trench 7</b>							
General description					Orientation		NW-SE
Trench devoid of archaeology. Consists of ploughsoil overlying the natural geology.					Length (m)		30
					Width (m)		2
					Avg. depth (m)		0.34
Context No.	Type	Fill Of	Width (m)	Depth (m)	Description	Finds	Date
700	Layer			0.34	Ploughsoil. Dark grey brown, silty clay		
701	Layer				Natural. Light orangey yellow, silty sand with frequent gravel patches		
<b>Trench 8</b>							
General description					Orientation		NW-SE
Trench revealed one ditch (803). Consisted of ploughsoil and subsoil overlying the natural geology					Length (m)		30
					Width (m)		2
					Avg. depth (m)		0.6
Context No.	Type	Fill Of	Width (m)	Depth (m)	Description	Finds	Date
800	Layer			0.33	Ploughsoil. Dark grey brown, silty clay		

801	Layer			0.27	Subsoil. Mid grey brown, silty sand with moderate gravel		
802	Layer				Natural. Mid orangey and red yellow, silty sand with frequent gravel		
803	Cut		2	0.26	Ditch		
804	Fill	803			Secondary Fill. Light grey brown, silt sand, with an abundance of gravel inclusions		
<b>Trench 9</b>							
General description						Orientation	NW-SE
Consisted of ploughsoil overlying the natural geology.  Trench 9 contained three ditches (903, 905 and 907) and a pit (910). Ditch 903 was located at the eastern edge of the trench, whilst ditches 905, 907 and pit 910 intercut each other in the centre of the trench.						Length (m)	30
						Width (m)	2
						Avg. depth (m)	0.33
Context No.	Type	Fill Of	Width (m)	Depth (m)	Description	Finds	Date
900	Layer			0.33	Ploughsoil. Dark grey brown, silty clay		
901	Layer				Natural. Mid orangey and red yellow, silty sand with frequent gravel		
902	Void						
903	Cut		1.04	0.33	Ditch		
904	Fill	903	1.04	0.33	Primary Fill. Mid brown grey silty sand. ~30% poorly sorted mixed gravel + pebbles.		
905	Cut		0.46	0.05	Ditch		
906	Fill	910	1.23	0.15	Primary Fill. Orange sand. Moderately loose. <5% mixed, poorly sorted gravel inclusions.		
907	Cut		0.86	0.13	Ditch		

908	Fill	907	0.86	0.13	Primary Fill. Dark brown grey silty sand. Moderately loose. ~ 30% mixed, poorly sorted gravel and pebbles.		
909	Fill	910	1.39	0.21	Secondary Fill. Mid brown grey silty sand. Moderately loose. ~30% poorly sorted mixed gravel + pebbles.		
910	Cut		1.41	0.37	Pit		
911	Fill	905	0.46	0.05	Primary Fill. Dark brown grey silty sand. Moderately loose. ~30% poorly sorted mixed gravel + pebbles.		
<b>Trench 10</b>							
General description						Orientation	NE-SW
Trench devoid of archeology. Consisted of ploughsoil overlying the natural geology						Length (m)	30
						Width (m)	2
						Avg. depth (m)	0.28
Context No.	Type	Fill Of	Width (m)	Depth (m)	Description	Finds	Date
1000	Layer			0.28	Ploughsoil. Dark greyish brown, silty sand		
1001	Layer				Natural. Mid yellowish brown, silty sand with gravel patches		
<b>Trench 11</b>							
General description						Orientation	E-W
Ploughsoil and subsoil overlying the natural geology.  Trench 11 contained one ditch (1103) and a posthole (1104) in the western end of the trench.						Length (m)	40
						Width (m)	2
						Avg. depth (m)	0.75



Context No.	Type	Fill Of	Width (m)	Depth (m)	Description	Finds	Date
1100	Layer			0.3	Ploughsoil. Dark grey brown, silty clay		
1101	Layer			0.25	Subsoil. Mid brown, silty sand with occasional gravel inclusions		
1102	Layer				Natural. Light grey yellow, silty sand		
1103	Cut		2.6	0.54	Ditch		
1104	Cut		0.44	0.48	Posthole		
1105	Fill	1104	0.44	0.48	Secondary Fill. Mottled mid grey black and mid orange yellow, with charcoal and gravel inclusions. Friable		
1106	Fill	1103	2.6	0.54	Primary Fill. Light brownish grey, silty sand		

## Trench 12

General description	Orientation	NW-SE
<p>Consisted of ploughsoil overlying the natural geology</p> <p>Trench 12 contained a possible pit/ ditch terminus (1204), a modern plough scar (1205) and a large modern feature (1203). The trench also contained two small possible sub-oval natural features (1206 and 1207) that were 0.4-0.5m wide with diffuse edges which had silty sandy fills (1214, 1215 respectively).</p>	Length (m)	30
	Width (m)	2
	Avg. depth (m)	0.31

Context No.	Type	Fill Of	Width (m)	Depth (m)	Description	Finds	Date
1200	Layer				Ploughsoil. Dark brown silty sand		
1201	Layer				Subsoil. Mid brown silty sand		
1202	Layer				Natural. Gravely sand		
1203	Cut		3.2	0.9	Modern		
1204	Cut		0.32	0.1	Pit		

1205	Cut		0.3	0.04	Plough Furrow		
1206	Cut		0.4	0.16	Natural Feature		
1207	Cut		0.52	0.18	Natural Feature		
1208	Fill	1203	1.3	0.4	Deliberate Backfill. Dark, brownish grey silty sand fill. Contained few pieces of modern pottery/ china.		
1209	Fill	1203	1.9	0.36	Deliberate Backfill. Soft, light yellowish brown silty sand fill. Contained no finds.		
1210	Fill	1203	2.3	0.4	Deliberate Backfill. Mid to dark greyish brown silty sand fill. Contained few pieces of modern pottery/china.		
1211	Fill	1203	2.1	0.56	Deliberate Backfill. Soft, dark brownish grey silty sand fill. Contained no finds.		
1212	Fill	1204	0.32	0.1	Deliberate Backfill. Uncertain formation process, maybe backfilled. Soft, dark brown silty coarse sand fill. Contained no finds.		
1213	Fill	1205	0.3	0.04	Secondary Fill. Soft, dark, brownish grey silty sand fill from plough scar, which is possible result the agricultural works. Contained no finds.		
1214	Fill	1206	0.4	0.16	Secondary Fill. Soft, friable mid-brown with orange patchy silty, gritty sandy fill. Contained no finds.		
1215	Fill	1207	0.52	0.18	Secondary Fill. Soft, dark, greyish brown silty, medium coarse sand fill. Possible animal burrowing. Contained no finds.		

### Trench 13

General description	Orientation	NE-SW
<p>Consisted of ploughsoil and subsoil overlying the natural geology.</p> <p>Trench 13 contained three ditches (1303/1307, 1305, 1311) and a shallow possible pit (1309) in the southern part of the trench. A yellow grey subsoil (1302) 0.29m thick was also recorded in this trench.</p>	Length (m)	30
	Width (m)	2

						Avg. depth (m)	0.59
Context No.	Type	Fill Of	Width (m)	Depth (m)	Description	Finds	Date
1300	Layer				Ploughsoil. Dark grey brown, silty clayey sand		
1301	Layer				Natural. Mid orange brown, silty sand with gravel patches		
1302	Layer			0.29	Subsoil. Mid yellowish grey silty sand, friable		
1303	Cut		0.4	0.1	Ditch		
1304	Fill	1303	0.4	0.1	Secondary Fill. Soft, mid brown silty sand, contains pottery.	Pottery (1)	Roman
1305	Cut		0.7	0.08	Other Cut. Unknown function and type. Could be shallow pit or ditch terminus.		
1306	Fill	1305	0.7	0.08	Secondary Fill. Soft light brown, silty sand with occ. pebbles and flints. No finds.		
1307	Cut		0.4	0.12	Ditch		
1308	Fill	1307	0.4	0.12	Secondary Fill. Soft, mid brown silty sand. No finds.		
1309	Cut		1.3	0.16	Other Cut. Unknown type and function. Could be pit, ditch or natural feature.		
1310	Fill	1309	1.3	0.16	Secondary Fill. Soft, mid brown silty sand. No finds.		
1311	Cut		1.2	0.16	Ditch		
1312	Fill	1311	1.2	0.16	Secondary Fill. Mid greyish brown, soft, silty sand. No finds.		
1313	Cut		0.7	0.12	Natural Feature		
1314	Fill	1313	0.7	0.12	Secondary Fill. Soft, greyish brown silty sand. No finds.		
<b>Trench 14</b>							
General description						Orientation	N-S

Trench devoid of archaeology. Consisted of ploughsoil overlying the natural geology						Length (m)	30
						Width (m)	2
						Avg. depth (m)	0.28
Context No.	Type	Fill Of	Width (m)	Depth (m)	Description	Finds	Date
1400	Layer			0.28	Ploughsoil. Dark grey brown, silty clay		
1401	Layer				Natural. Mid orange brown, silty sand with gravel patches		
<b>Trench 15</b>							
General description						Orientation	E-W
Trench consisted of ploughsoil overlying the natural geology.						Length (m)	30
Trench 15 contained one ditch (1513) and a cremation pit (1509) in the western part of the trench.						Width (m)	2
						Avg. depth (m)	0.25
Context No.	Type	Fill Of	Width (m)	Depth (m)	Description	Finds	Date
1500	Layer			0.25	Ploughsoil. Dark grey brown, silty clay		
1501	Layer				Natural. Mid orange brown, silty sand with gravel patches		
1502	Fill	1509			Deliberate Backfill. Mid grey brown silty sand		
1503	Fill	1509			Placed Deposit. Black bowl (pottery), Small Find #100	Pottery (23)	AD 120-410
1504	Fill	1509			Placed Deposit. Samian plate, Small Find #101	Pottery (23)	120-150
1505	Fill	1509			Placed Deposit. Fill of ceramic bottle, Small Find #102		
1506	Fill	1509			Placed Deposit. Ceramic bottle small find # 102	Pottery (10)	100-200
1507	Fill	1509			Cremation Deposit		

1508	Fill	1509			Cremation Container. Ceramic pot small find #103	Pottery (69)	125-200
1509	Cut				Cremation Cut		
1510	Fill	1509			Placed Deposit. Fill of black ceramic bottle small find # 104		
1511	Fill	1509			Placed Deposit. Full black bottle small find #104	Pottery (1)	100-200
1512	Fill	1513			Primary Fill. Mid grey brown silty sand and gravel	Pottery (12)	Roman
1513	Cut		1.2	0.5	Ditch		

### Trench 16

General description	Orientation	E-W
Trench devoid of archaeology. Consisted of ploughsoil and subsoil overlying the natural geology.	Length (m)	25
	Width (m)	2
	Avg. depth (m)	0.32

Context No.	Type	Fill Of	Width (m)	Depth (m)	Description	Finds	Date
1600	Layer			0.26	Topsoil. Dark brown grey sandy silt		
1601	Layer			0.06	Subsoil. Mid grey brown silty sand		
1602	Layer				Natural. Mid brown yellow sand and gravels		

### Trench 17

General description	Orientation	N-S
Consisted of ploughsoil and subsoil layers which overlay the natural geology  Trench 17 contained one pit (1703) and one furrow (1705).	Length (m)	30
	Width (m)	2
	Avg. depth (m)	0.32

Context No.	Type	Fill Of	Width (m)	Depth (m)	Description	Finds	Date
1700	Layer			0.26	Ploughsoil. Dark grey brown, silty clay		
1701	Layer			0.06	Subsoil. Mid grey brown, silty clay		
1702	Layer				Natural. Mid orange brown, silty sand with gravel patches		
1703	Cut		0.66	0.22	Pit		
1704	Fill	1703		0.22	Secondary Fill. dark grey sandy silt		
1705	Cut		0.98	0.19	Plough Furrow		
1706	Fill	1705		0.19	Secondary Fill. mid yellow grey sandy silt		
<b>Trench 18</b>							
General description					Orientation	NW-SE	
Consisted of ploughsoil overlying the natural geology Trench 18 contained a NE-SW aligned ditch (1803)					Length (m)	30	
					Width (m)	2	
					Avg. depth (m)	0.41	
Context No.	Type	Fill Of	Width (m)	Depth (m)	Description	Finds	Date
1800	Layer		2	0.32	Ploughsoil. Dark greyish brown, silty sand		
1801	Layer			0.13	Natural. Mid brown orange, silty sand		
1802	Fill	1803		0.41	Placed Deposit. Mid grey brown, silty sand	Pottery (34), Fired clay	Late Neolithic/early Bronze Age
1803	Cut		0.61	0.41	Ditch. Possible ditch		
1804	Void						
1805	Cut		0.9	0.1	Natural Feature. Natural feature		

1806	Layer		0.9	0.1	Natural. Test slot, natural. See 1802 for description		
<b>Trench 19</b>							
General description					Orientation	N-S	
Trench devoid of archaeology. Consisted of ploughsoil overlying the natural geology					Length (m)	30	
					Width (m)	2	
					Avg. depth (m)	0.27	
Context No.	Type	Fill Of	Width (m)	Depth (m)	Description	Finds	Date
1900	Layer		2	0.27	Ploughsoil. Dark greyish brown, silty sand		
1901	Layer		2		Natural. Mid orange brown, silty sand		
<b>Trench 20</b>							
General description					Orientation	N-S	
Trench devoid of archaeology. Consisted of ploughsoil overlying the natural geology					Length (m)	30	
					Width (m)	2	
					Avg. depth (m)	0.2	
Context No.	Type	Fill Of	Width (m)	Depth (m)	Description	Finds	Date
2000	Layer			0.31	Ploughsoil. Dark grey brown, silty clay		
2001	Layer				Natural. Mid orange brown with gravel patches, silty sand		
<b>Trench 21</b>							

General description					Orientation	NE-SW	
Consisted of ploughsoil and subsoil overlying the natural geology  Trench 21 contained one ditch (2103) aligned roughly east-west.					Length (m)	30	
					Width (m)	2	
					Avg. depth (m)	0.47	
Context No.	Type	Fill Of	Width (m)	Depth (m)	Description	Finds	Date
2100	Layer				Ploughsoil. Mid brown sandy silt.		
2101	Layer				Subsoil. Mid orangey brown sandy silt.		
2102	Layer				Natural. Mostly orangey sand. Frequent pebbles/gravel.		
2103	Cut		0.78	0.14	Ditch. Bioturbated, edges fuzzy		
2104	Fill	2103			Primary Fill. Light red yellow silty sand		
<b>Trench 22</b>							
General description					Orientation	N/A	
Trench devoid of archaeology. Consisted of ploughsoil and subsoil overlying the natural geology.					Length (m)	12	
					Width (m)	15	
					Avg. depth (m)	0.47	
Context No.	Type	Fill Of	Width (m)	Depth (m)	Description	Finds	Date
2200	Layer			0.21	Topsoil. Mid grey brown silty sand, friable		
2201	Layer			0.26	Subsoil. Mid yellow grey, silt sand, with large gravel patches		
2202	Layer				Natural. Mid yellow orange, silt sand, loose		



Trench 23							
General description					Orientation		N/A
Trench devoid of archaeology. Consisted of ploughsoil and subsoil overlying the natural geology					Length (m)		10
					Width (m)		10
					Avg. depth (m)		0.45
Context No.	Type	Fill Of	Width (m)	Depth (m)	Description	Finds	Date
2300	Layer			0.35	Ploughsoil. Dark grey brown, silty clay		
2301	Layer			0.08	Subsoil. Mid grey brown, silty sand with gravel inclusions		
2302	Layer				Natural. Light orangey yellow, silty sand with gravel patches		
Trench 24							
General description					Orientation		NE-SW
Consisted of ploughsoil overlying the natural geology.  Trench 24 contained a ditch (2402) and a possible unexcavated ditch (2404).					Length (m)		30
					Width (m)		2
					Avg. depth (m)		0.3
Context No.	Type	Fill Of	Width (m)	Depth (m)	Description	Finds	Date
2400	Layer			0.3	Ploughsoil. Dark grey brown, silty clay		
2401	Layer				Natural. Light orangey yellow, silty sand		
2402	Cut		2	0.36	Ditch		
2403	Fill	2402	2	0.36	Secondary Fill. mid yellow brown sandy silt		
2404	Unexcavated feature		1.6		Ditch		

<b>Trench 25</b>							
General description					Orientation		NE-SW
Trench devoid of archaeology. Consisted of ploughsoil overlying the natural geology.					Length (m)		30
					Width (m)		2
					Avg. depth (m)		0.29
Context No.	Type	Fill Of	Width (m)	Depth (m)	Description	Finds	Date
2500	Layer			0.29	Ploughsoil. Dark grey brown, silty clay		
2501	Layer				Natural. mid yellow brown silt sand		
<b>Trench 26</b>							
General description					Orientation		N-S
Consisted of ploughsoil overlying the natural geology.  Trench 26 contained one ditch (2602) which was aligned ENE-WSW					Length (m)		30
					Width (m)		2
					Avg. depth (m)		0.28
Context No.	Type	Fill Of	Width (m)	Depth (m)	Description	Finds	Date
2600	Layer			0.33	Ploughsoil. Dark grey brown, silty clay		
2601	Layer				Natural. Mid orange brown, silty sand		
2602	Cut		0.88	0.24	Ditch		
2603	Fill	2602	0.88	0.24	Secondary Fill. Mid orange brown, silty sand, friable		

<b>Trench 27</b>							
General description					Orientation		E-W
Consisted of ploughsoil and subsoil overlying the natural geology. Trench 27 contained one ditch (2703) aligned roughly north-south					Length (m)		30
					Width (m)		2
					Avg. depth (m)		0.39
Context No.	Type	Fill Of	Width (m)	Depth (m)	Description	Finds	Date
2700	Layer			0.28	Ploughsoil. Dark grey brown, silty clay		
2701	Layer			0.1	Subsoil. Mid grey brown, silty clay		
2702	Layer				Natural. Mid orange brown, silty sand with gravel patches		
2703	Cut				Ditch		
2704	Fill	2703			Primary Fill. Dark grey brown, silty sand with gravel inclusions		
<b>Trench 28</b>							
General description					Orientation		NE-SW
Consisted of ploughsoil and subsoil overlying the natural geology. Trench 28 contained two ditches 2803, 2804 and pit 2805. Ditch 2803 was unexcavated but was observed in plan.					Length (m)		30
					Width (m)		2
					Avg. depth (m)		0.41
Context No.	Type	Fill Of	Width (m)	Depth (m)	Description	Finds	Date
2800	Layer			0.3	Ploughsoil. Dark grey brown, silty clay		
2801	Layer			0.11	Subsoil. Mid grey brown, silty clay		
2802	Layer				Natural. Mid orange brown, silty sand, with gravel patches		

2803	Unexcavated feature		2		Ditch. SE-NW aligned unexcavated linear. Mid orange brown, friable, silty sand fill.		
2804	Cut		0.5	0.09	Ditch		
2805	Cut		0.47	0.23	Pit		
2806	Fill	2804		0.09	Secondary Fill. Mid grey brown silty sand		
2807	Fill	2805		0.27	Secondary Fill. Mid grey brown silty sand		
<b>Trench 29</b>							
General description					Orientation	N-S	
Consisted of ploughsoil overlying the natural geology  Trench 29 contained two ditches (2903, 2910) and a pit (2905). Another ditch was located towards the south of the trench but was not excavated.					Length (m)	30	
					Width (m)	2	
					Avg. depth (m)	0.32	
Context No.	Type	Fill Of	Width (m)	Depth (m)	Description	Finds	Date
2900	Layer			0.3	Ploughsoil. Dark grey brown, silty clay		
2901	Layer			0.14	Subsoil. Mid grey brown, silty clay		
2902	Layer				Natural. Mid orange brown, silty sand with gravel patches		
2903	Cut		2.8	0.44	Ditch		
2904	Fill	2903	2.8	0.44	Primary Fill. Medium orange brown silty sand		
2905	Cut		0.8	0.3	Pit		
2906	Fill	2905	0.8	0.3	Primary Fill. Medium greyish brown silty sand Cut by pit [2907]		
2907	Cut		0.4	0.16	Pit		
2908	Fill	2907	0.4	0.16	Primary Fill. Medium Orange brown silty sand		

2909	Cut		0.8	0.25	Natural Feature. Test pit		
2910	Cut				Ditch		
2911	Fill	2910			Secondary Fill. Mid grey brown, silty sand		
<b>Trench 30</b>							
General description					Orientation	NW-SE	
Consisted of ploughsoil and subsoil layer overlying the natural geology  Trench 30 contained three ditches (3005, 3008, 3010) and a single pit (3003).					Length (m)	30	
					Width (m)	2	
					Avg. depth (m)	0.3	
Context No.	Type	Fill Of	Width (m)	Depth (m)	Description	Finds	Date
3000	Layer			0.26	Ploughsoil. Dark grey brown, silty clay		
3001	Layer			0.06	Subsoil. Mid grey brown, silty clay		
3002	Layer				Natural. Mid orange brown, silty sand with gravel patches		
3003	Cut		0.83	0.31	Pit		
3004	Fill	3003			Primary Fill. Mid brown silt.		
3005	Cut		0.67	0.17	Ditch		
3006	Fill	3005	0.67	0.17	Primary Fill. Mid brown sandy silt and gravel		
3007	Fill	3005	0.34	0.17	Secondary Fill. Mid orange brown sandy silt and gravel		
3008	Cut		1.36	0.25	Ditch		
3009	Fill	3008			Primary Fill. Mid orange brown silty sand and gravel		
3010	Cut		0.92	0.54	Ditch		

3011	Fill	3010	0.92	0.54	Primary Fill. Mid grey brown silty sand, large amounts of sub-rounded gravel	Worked flint	Earlier prehistoric?
<b>Trench 31</b>							
General description					Orientation		NE-SW
Trench devoid of archaeology. Consists of ploughsoil and subsoil overlying the natural geology of silty sand.					Length (m)		30
					Width (m)		2
					Avg. depth (m)		0.46
Context No.	Type	Fill Of	Width (m)	Depth (m)	Description	Finds	Date
3100	Layer			0.28	Ploughsoil. Dark grey brown, silty clay		
3101	Layer			0.18	Subsoil. Mid orangey brown, sandy silt		
3102	Layer				Natural. Mid reddish brown, silty sand with occasional gravel inclusions		
<b>Trench 32</b>							
General description					Orientation		NE-SW
Consists of ploughsoil and subsoil layer overlying the natural geology of silty sand.  Trench 32 contained a ditch (3203) aligned north-west to south-east.					Length (m)		30
					Width (m)		2
					Avg. depth (m)		0.48
Context No.	Type	Fill Of	Width (m)	Depth (m)	Description	Finds	Date
3200	Layer			0.28	Ploughsoil. Dark grey brown, silty clay		
3201	Layer			0.2	Subsoil. Mid orangey brown, sandy silt		
3202	Layer				Natural. Mid reddish brown, silty sand with		

					occasional gravel inclusions		
3203	Cut		1.23	0.34	Ditch		
3204	Fill	3203	1.23	0.34	Primary Fill. Mid grey brown silty sand		
<b>Trench 33</b>							
General description						Orientation	NE-SW
Consists of Ploughsoil and subsoil overlying natural geology of silty sand with gravels.  Trench 33 contained 12 pits, one of which was excavated (3303) and a possible kiln/oven (3311) which remains unexcavated.						Length (m)	30
						Width (m)	2
						Avg. depth (m)	0.55
Context No.	Type	Fill Of	Width (m)	Depth (m)	Description	Finds	Date
3300	Layer			0.25	Ploughsoil. Mid grey brown, sandy silt		
3301	Layer			0.3	Subsoil. Mid orange brown, sandy silt		
3302	Layer				Natural. Mid brown orange, clayey silt with occasional gravel patches		
3303	Cut		0.41	0.16	Pit		
3304	Fill	3303	0.41	0.14	Deliberate Backfill. Dark brown grey, sandy silt	Pottery (2)	AD 1270-1350
3305	Fill	3303	0.24	0.04	Secondary Fill. Mid grey brown, sandy silt		
3306	Unexcavated feature		0.6		Pit. Mid red brown, sandy silt		
3307	Unexcavated feature		1.3		Other Cut. Potential kiln/oven. Irregular shape in plan with red halo and charcoal deposits around feature edges in some parts.		
3308	Unexcavated feature		1.28		Pit. Mid grey brown, silt	Pottery (1)	Roman
3309	Unexcavated feature		0.28		Pit. Mid grey brown, silt		

3310	Unexcavated feature		0.38		Pit. Mid grey brown, silt		
3311	Unexcavated feature		0.76		Other Cut. Possible kiln/oven. Mid grey brown with partially halo-ed orangey red, silt		
3312	Unexcavated feature		0.5		Pit. Mid orangey brown, silt		
3313	Unexcavated feature		2.36		Other Cut. Light brownish yellow with patches of mid yellow brown, reddish brown and black, sandy silt		
3314	Unexcavated feature		0.66		Other Cut. Possible oven/kiln. Mid reddish brown, clayey silt		
3315	Unexcavated feature		0.98		Other Cut. Mid greyish brown, sandy silt		
3316	Unexcavated feature		1.28		Pit. Mid greyish brown, sandy silt		

#### Trench 34

General description	Orientation	NE-SW
Trench devoid of archaeology. Consists of ploughsoil and subsoil overlying natural geology of silty sand with gravels.	Length (m)	19
	Width (m)	2
	Avg. depth (m)	0.35

Context No.	Type	Fill Of	Width (m)	Depth (m)	Description	Finds	Date
3400	Layer			0.2	Ploughsoil. Dark grey brown silty clay		
3401	Layer			0.15	Subsoil. Mid orange brown sandy silt		
3402	Layer				Natural. Mixed mid yellow brown and mid orange brown silty sand with gravels		

#### Trench 35

General description	Orientation	NE-SW
---------------------	-------------	-------



Consists of ploughsoil and subsoil layer overlying the natural geology of silty sand.  Trench 35 contained two ditches (3505, 3506) aligned north-west to south-east.						Length (m)	30
						Width (m)	2
						Avg. depth (m)	0.45
Context No.	Type	Fill Of	Width (m)	Depth (m)	Description	Finds	Date
3500	Layer			0.27	Ploughsoil. Dark grey brown, silty clay		
3501	Layer			0.18	Subsoil. Mid orangey brown, sandy silt		
3502	Layer				Natural. Mid red brown, silty sand with gravel inclusions		
3503	Cut		0.76	0.3	Ditch		
3504	Fill	3503	0.76	0.3	Secondary Fill. Mid grey slight orange, sandy silt		
3505	Cut		0.51	0.13	Ditch		
3506	Fill	3505	0.51	0.13	Secondary Fill. mid brownish grey		
<b>Trench 36</b>							
General description						Orientation	E-W
Consists of ploughsoil and subsoil overlying natural geology of silty sand with gravels.  Trench 36 contained three ditches (3603, 3605, 3607), a plough scar (3609) and an unexcavated feature (3611). All of these features were aligned roughly north-south.						Length (m)	30
						Width (m)	2
						Avg. depth (m)	0.47
Context No.	Type	Fill Of	Width (m)	Depth (m)	Description	Finds	Date
3600	Layer			0.3	Topsoil. Dark blackish grey clayey silt		
3601	Layer			0.17	Subsoil. Mid grey brown clayey sand		
3602	Layer				Natural. Mid orangey brown sand with gravelly patches		

3603	Cut		0.55	0.08	Ditch. North-south ditch/gully		
3604	Fill	3603	0.55	0.08	Secondary Fill. Mid grey brown clayey sand		
3605	Cut		0.92	0.38	Ditch. North-south boundary ditch		
3606	Fill	3605	0.92	0.38	Secondary Fill. Mid grey brown clayey sand		
3607	Cut		0.8	0.34	Ditch. North-south boundary ditch recut		
3608	Fill	3607	0.8	0.34	Deliberate Backfill. Dark blackish grey clayey sand with lenses of mid brown grey		
3609	Cut		0.34	0.1	Other Cut. North-south linear. The result of earlier ploughing activity		
3610	Fill	3609	0.34	0.1	Secondary Fill. Mid grey brown clayey sand		
3611	Unexcavated feature		0.38		Other Cut. Mid grey brown clay sand		

### Trench 37

General description					Orientation	E-W	
Consists of ploughsoil and subsoil overlaying natural geology of silty sand with gravels  Trench contained one north-south aligned ditch (3703) which was unexcavated.					Length (m)	30	
					Width (m)	2	
					Avg. depth (m)	0.45	
Context No.	Type	Fill Of	Width (m)	Depth (m)	Description	Finds	Date
3700	Layer			0.35	Ploughsoil. Mid grey brown silty clay		
3701	Layer			0.2	Subsoil. Mid yellow brown silty clay		
3702	Layer				Natural. Mid yellow brown silty clay frequent gravel		
3703	Unexcavated feature		1.1		Ditch. Continuation of ditch excavated in trench 36. Mid grey brown silty clay, medium rounded pebbles.		

<b>Trench 38</b>							
General description					Orientation		E-W
Consists of ploughsoil and subsoil overlying natural geology of silt sand.  Trench 38 contained one north-south aligned furrow (3804) at the eastern end of the trench.					Length (m)		30
					Width (m)		2
					Avg. depth (m)		0.44
Context No.	Type	Fill Of	Width (m)	Depth (m)	Description	Finds	Date
3800	Layer			0.3	Topsoil. Mid grey brown, sandy silt, friable		
3801	Layer			0.1	Subsoil. Mid brown orange, silt sand, friable		
3802	Layer				Natural. Light brownish orange, friable, silty gravel,		
3803	Fill		0.72	0.09	Secondary Fill. Mid orange brown, silty clay with fine gravel inclusions. Truncated by l o ex. Same as ditch [10703]		
3804	Cut		0.72	0.09	Plough Furrow. Linear, single fill (3803)		
<b>Trench 39</b>							
General description					Orientation		NW-SE
Consists of ploughsoil overlying natural geology.  Trench 39 contained two small ovens (structures 3914, 3919), two north-south aligned ditches (3905, 3908) and one NNW-SSE aligned ditch (3911) and three pits (3903, 3925, 3927).					Length (m)		30
					Width (m)		2
					Avg. depth (m)		0.3
Context No.	Type	Fill Of	Width (m)	Depth (m)	Description	Finds	Date
3900	Layer			0.3	Topsoil. Mid grey brown silt sand		

3901	Layer				Natural. Mid yellow orange silt sand, large patches of gravel		
3902	Fill	3915	1.38	0.05	Secondary Fill. mid greyish brown, silty clay	Pottery (1)	Roman
3903	Cut		1.38	0.12	Pit. Sub-circular, flat base	Pottery (5)	AD 120-410
3904	Fill	3903	1.38	0.12	Secondary Fill. Mid orange-brown, sandy silt with patches of large gravel inclusions		
3905	Cut		1.49	0.45	Ditch. Linear, v-shaped		
3906	Fill	3905	1.49	0.31	Secondary Fill. Mid orange-brown, Sandy-silt with large patches of gravel		
3907	Fill	3905	1.49	0.16	Secondary Fill. Mid greyish-brown, silty clay		
3908	Cut		0.8	0.3	Ditch. Linear N-S		
3909	Fill	3908	0.8	0.3	Secondary Fill. Mid to dark brownish grey, gravelly sandy silt	Pottery (1)	Roman
3910	Fill	3908	0.14	0.1	Secondary Fill. Mid brownish orange, gravelly sandy silt		
3911	Cut		2.45	0.43	Ditch. Linear NNW-SSE		
3912	Fill	3911	2.45	0.32	Secondary Fill. Mid to dark brownish grey, sandy silt	Pottery (10)	late IA/ER
3913	Fill	3911	2.45	0.11	Secondary Fill. Mid to dark grey, sandy silt		
3914	Layer		0.37	0.19	Other Layer. Oven/kiln lining		
3915	Cut		0.37	0.19	Other Cut. Sub-circular cut of oven/hearth 3914		
3916	Fill	3915	0.17	0.04	Secondary Fill. Mid yellowish brown, sandy silt		
3917	Fill	3915	0.27	0.06	Other Fill. Dark grey, silt with frequent charcoal inclusions. In situ burning.		
3918	Fill	3915	0.34	0.11	Secondary Fill. Mid brownish grey, silty clay	Pottery (2)	AD 120-200
3919	Fill		0.52	0.22	Other Fill. Roman oven/kiln		
3920	Cut		0.52	0.22	Other Cut. Sub circular		

3921	Fill	3920	0.26	0.04	Secondary Fill. Mid yellowish-brown, silty sand		
3922	Layer		0.52	0.12	In situ Burning. Final firing layer in Roman oven 3920. Dark grey silt, rich in charcoal.		
3923	Fill	3920	0.52	0.08	Secondary Fill. Mid greyish-brown, silty clay	Pottery (5)	Roman
3924	Fill	3920	0.52	0.05	Secondary Fill. Mid orange-brown, silty clay		
3925	Cut		1.94	0.75	Pit. Oval		
3926	Fill	3925	1.94	0.75	Primary Fill. Mid grey brown silty sand	Pottery (38)	AD 43-100
3927	Cut		2.05	0.69	Pit		
3928	Fill	3927	2.05	0.69	Primary Fill. Mid grey brown silty sand	Pottery (3)	middle Iron Age

#### Trench 40

General description	Orientation	NE-SW
Consists of ploughsoil and subsoil overlying natural geology of silty sand  Trench 40 contained three excavated ditches (4005, 4007, 4009) and two unexcavated ditches (4011, 4013).	Length (m)	30
	Width (m)	2
	Avg. depth (m)	0.33

Context No.	Type	Fill Of	Width (m)	Depth (m)	Description	Finds	Date
4000	Layer			0.33	Ploughsoil. Dark grey brown clay silt		
4001	Layer				Natural. Mid orange brown sandy gravel		
4002	Void						
4003	Fill	4005	1.1	0.1	Tertiary Fill. Dark grey black clay silt	Pottery (108), CBM, fired clay	AD 240-410
4004	Fill	4005	1.3	0.08	Secondary Fill. Mid green grey silty clay		
4005	Cut		2.94	0.54	Ditch. Cut of ditch, not bottomed. Base not found as max. depth of		

					1m from top of trench was reached.		
4006	Fill	4005	2.94	0.54	Secondary Fill. Dark grey clayey silt, loose. Not fully excavated, as max. depth of 1m from top of trench was reached.	Pottery (341), CBM, fired clay, worked flint (res Neo-EBA)	AD 150-250 with M-LIA (res) component
4007	Cut		1.62	0.51	Ditch		
4008	Fill	4007	1.62	0.51	Secondary Fill. Mid grey brown clayey silt, loose	Pottery (62), fired clay	AD 43-70
4009	Cut		0.82	0.4	Ditch		
4010	Fill	4009	0.82	0.4	Secondary Fill. Mid brown grey clayey silt, loose		
4011	Unexcavated feature		4.5		Ditch. Ditch running NW-SE, possible large enclosure in the area registered by the geophysics.	Pottery (5)	Roman
4012	Unexcavated feature				Natural Feature. Possible colluvial layer finds recovered	Pottery (1), fired clay	AD 200-410
4013	Unexcavated feature		3.5		Ditch. Possible ditch, running NW-SE, looks like merging with 4011 towards SE. Probably part of a bigger boundary system.		

#### Trench 41

General description					Orientation	NW-SE	
Consists of ploughsoil overlying natural geology of silty sand with gravels.  Trench 41 contained four linear ditches (4106, 4111, 4114, 4116), a curvilinear ditch (4109) and two pits (4102, 4104).					Length (m)	30	
					Width (m)	2	
					Avg. depth (m)	0.3	
Context No.	Type	Fill Of	Width (m)	Depth (m)	Description	Finds	Date
4100	Layer			0.3	Ploughsoil. Mid grey brown silty clay		
4101	Layer				Natural. Mid orange brown silty sand with gravels		

4102	Cut		0.61	0.22	Pit		
4103	Fill	4102	0.61	0.22	Primary Fill. Mid grey brown silty sand		
4104	Cut		0.52	0.13	Pit		
4105	Fill	4104	0.52	0.13	Primary Fill. Mid grey brown silty sand		
4106	Cut		1.02	0.37	Ditch. Linear, base flat, sides rounded concave		
4107	Fill	4106	1.02	0.18	Other Fill. Mid brownish grey, sandy silt	Pottery (2)	late IA/ER
4108	Fill	4106	0.79	0.18	Deliberate Backfill. Dark greyish brown, silty sand	Pottery (1), fired clay	late IA/ER
4109	Cut		0.94	0.3	Ditch. Curvilinear - possible ring ditch	Pottery (1)	late IA/ER
4110	Fill	4109	0.94	0.3	Primary Fill. Mid grey brown silty sand		
4111	Cut		1.41	0.58	Ditch		
4112	Fill	4111	0.36	0.2	Primary Fill. Mid yellow brown silty sand		
4113	Fill	4111	1.41	0.38	Secondary Fill. Mid grey brown silty sand	Pottery (1), fired clay	Roman
4114	Cut		0.65	0.17	Ditch		
4115	Fill	4114	0.65	0.17	Primary Fill. Mid grey brown silty sand	Pottery (1)	Mid/late Iron Age
4116	Cut		1.5	0.36	Ditch		
4117	Fill	4116	1.5	0.36	Primary Fill. Mid greyish brown, sandy gravel silt		

#### Trench 42

General description	Orientation	N-S
Consists of ploughsoil and subsoil overlying a natural geology of silty sand with gravels.  Trench 42 contained several features which extended outside the boundary of the trench. This included a possible ring ditch (4203),	Length (m)	30
	Width (m)	2

possible ditches (4208, 4210, 4212), large pit (4205, 4214) and small pit 4216.						Avg. depth (m)	0.62
Context No.	Type	Fill Of	Width (m)	Depth (m)	Description	Finds	Date
4200	Layer			0.32	Topsoil. Mid grey brown, silty clay		
4201	Layer			0.25	Ploughsoil. Mid grey brown, silty sand		
4202	Layer				Natural. Mid orange brown, silty sand with occasional fine gravel		
4203	Cut		0.97	0.18	Pit or possible ring ditch. Sub oval.		
4204	Fill	4203	0.97	0.18	Secondary Fill. Mid orange brown, silty sand.		
4205	Cut		6.6	0.5	Pit		
4206	Fill	4205	6.6	0.3	Primary Fill. Mid orange brown silty sand	Coin	1st or 2nd century
4207	Fill	4205	0.7	0.19	Secondary Fill. Dark brown silty sand	Fired clay	
4208	Cut		1.98	0.11	Other Cut. Possible ditch or pit		
4209	Fill	4208	1.98	0.11	Primary Fill. Light grey, silty sand	Pottery	Late Bronze Age/early Iron Age
4210	Cut		0.8	0.28	Ditch		
4211	Fill	4210	0.8	0.28	Primary Fill. Mid grey brown silty sand		
4212	Cut		1.05	0.23	Other Cut. Unknown function.		
4213	Fill	4212	1.05	0.23	Primary Fill. Mid grey brown, silty sand		
4214	Cut		6.6	0.32	Pit		
4215	Fill	4214	6.6	0.32	Primary Fill. Mid orange brown silty sand		
4216	Cut		0.5	0.26	Pit		
4217	Fill	4216	0.5	0.26	Primary Fill. Mid grey brown silty sand		



Trench 43							
General description					Orientation		NE-SW
Trench 43 contained one excavated pit (4308), one unexcavated ditch (4303) and three unexcavated pits (4304, 4305 and 4307). This trench contained a ploughsoil (4300) overlying a colluvial layer (4301) which contained multiple sherds of Roman pottery which sealed a grey brown silty sandy subsoil (4309) which in turn overlay the natural geology (4302) of silty sand with gravels.					Length (m)		30
					Width (m)		2
					Avg. depth (m)		0.7
Context No.	Type	Fill Of	Width (m)	Depth (m)	Description	Finds	Date
4300	Layer			0.3	Topsoil. Mid grey brown silty clay		
4301	Layer			0.4	Colluvial Layer. Mid grey brown silty sand with occasional stone inclusions and pottery	Pottery (87)	Roman
4302	Layer				Natural. Mid orange brown silty sand with occasional gravels		
4303	Unexcavated feature		7.48		Ditch. mid orange brown, sandy silt.	Pottery (2)	Roman
4304	Unexcavated feature		2.39		Pit. Mid orange brown, sandy silt		
4305	Unexcavated feature		2.21		Pit. mid orange brown, sandy silt		
4306	Fill	4308	1.58	0.18	Secondary Fill. Mid greyish brown, sandy silt		
4307	Unexcavated feature		1.71		Pit. Mid orange brown, sandy silt		
4308	Cut		1.58	0.18	Pit		
4309	Layer			0.23	Subsoil. Mid greyish brown, silty sand		
Trench 44							
General description					Orientation		NW-SE
Trench devoid of archaeology. Consists of ploughsoil and subsoil overlying the natural geology.					Length (m)		30
					Width (m)		2

						Avg. depth (m)	0.46
Context No.	Type	Fill Of	Width (m)	Depth (m)	Description	Finds	Date
4400	Layer			0.27	Ploughsoil. Mid brown sandy silt		
4401	Layer			0.19	Subsoil. Mid brownish orange silty sand		
4402	Layer				Natural. Light brown sandy silt		
<b>Trench 45</b>							
General description						Orientation	NE-SW
Consists of ploughsoil and subsoil overlying natural geology of sandy silt.  Trench 45 contained a pottery kiln (group 4503), three ditches (4507, 4514 and 4517) and a possible cremation (4510).						Length (m)	30
						Width (m)	2
						Avg. depth (m)	0.55
Context No.	Type	Fill Of	Width (m)	Depth (m)	Description	Finds	Date
4500	Layer			0.3	Ploughsoil. Mid grey brown silty clay		
4501	Layer			0.25	Subsoil. Light grey brown silty sand		
4502	Layer				Natural. Light yellow brown silty sand		
4503	Group		5		Structure. Kiln structure		
4504	Unexcavated feature		3		Other Cut. Dark brownish grey sandy silt	Pottery, brooch, fired clay	AD 180-200/1st century brooch
4505	Unexcavated feature		2		Other Cut. Mid reddish brown centre followed by a yellow lens and a black outer lens of sandy silt	Pottery, fired clay	AD 350-410
4506	Unexcavated feature		0.36		Ditch. Mid slightly reddish brown sandy silt	Pottery (20) , fired clay	AD 140-250
4507	Cut		2.24	0.4	Ditch. base not reached		

4508	Fill	4507	2.15	0.18	Secondary Fill. Dark brownish grey sandy silt	Pottery (191), CBM, fired clay	AD 350-410
4509	Fill	4507	1.66	0.22	Secondary Fill. Light-mid brownish grey sandy silt	Pottery (190), fired clay, worked flint (res ?EPH)	AD 230-300
4510	Group		0.4	0.11	Cremation Cut		
4511	Cut		0.35	0.06	Cremation Cut		
4512	Fill	4511	0.35	0.06	Cremation Deposit. Mid brownish grey sandy silt	Fired clay	
4513	Fill		0.4	0.05	Other Fill. Light-mid yellowish brown sandy silt		
4514	Cut		2.56	0.52	Ditch		
4515	Fill	4514	2.56	0.48	Primary Fill. Mid grey brown silty sand, occasional small rounded stones	Pottery (75), CBM	AD 230-300
4516	Fill	4514	1.08	0.14	Secondary Fill. Dark grey brown silty sand, occasional small rounded stones		
4517	Cut		2.38	0.55	Ditch		
4518	Fill	4517	2.38	0.55	Primary Fill. Mid grey brown silty sand, occasional small rounded stones	Pottery (3)	LIA-ER
<b>Trench 46</b>							
General description						Orientation	E-W
Consists of ploughsoil and subsoil overlying natural geology of silty sand.  Trench 46 contained two ditches (4603, 4614), two pits (4606, 4608) and layer (4612/4621). It also contained a possible oven 4619 and an area of possible rake out 4620 in the western part of the trench.						Length (m)	30
						Width (m)	2
						Avg. depth (m)	0.5
Context No.	Type	Fill Of	Width (m)	Depth (m)	Description	Finds	Date
4600	Layer			0.3	Topsoil. Mid grey brown silty clay		

4601	Layer			0.2	Subsoil. Mid orange brown silty sand		
4602	Layer				Natural. Mid orange brown silty sand		
4603	Cut		1.94	0.34	Ditch		
4604	Fill	4603	1.94	0.17	Primary Fill. Sandy silt orangey brown	Fired clay	
4605	Fill	4603	1.55	0.2	Secondary Fill. Clayey silt light greyish brown	Pottery (45)	AD 140-250
4606	Cut		0.62	0.09	Other Cut. Possible oven	Pottery (5)	Roman
4607	Fill	4606	0.62	0.09	Other Fill. Burnt fill of oven, mid blueish grey, abundant charcoal fragments		
4608	Cut		0.88	0.31	Pit. 3 fills (4609) (4610) (4611)		
4609	Fill	4608	0.56	0.15	Secondary Fill. Mid yellowish brown, silt. Top fill of pit		
4610	Fill	4608	0.88	0.24	Secondary Fill. Mid yellowish brown, silt. 2nd fill of pit	Fired clay	
4611	Fill	4608	0.53	0.09	Other Fill. In situ burnt material forming basal fill of pit, sample 8	Fired clay	
4612	Cut			0.11	Other Cut. Cut of unidentified feature or spread. Truncated by pit [4608]		
4613	Fill	4612	0.74	0.11	Secondary Fill. Mid orangey grey, sandy silt	Fired clay	
4614	Cut		1.78	0.48	Ditch. Linear SE-NW		
4615	Fill	4614	0.86	0.18	Secondary Fill. Dark Orangey grey sandy silt, friable	CBM, fired clay	Medieval
4616	Fill	4614	1.36	0.36	Secondary Fill. Dark orangey brown, sandy silt	Fired clay	
4617	Fill	4614	1.78	0.46	Primary Fill. Mid brownish orange, silty sand	Fired clay	
4618	Layer			0.22	Other Layer. Dark brownish grey, sandy silt		
4619	Unexcavated feature		1		Other Cut. Possible oven, mid greyish brown silty clay		
4620	Unexcavated feature		0.5		Other Cut. Probable rake out from nearby ovens, dark brownish grey, sandy silt		

4621	Cut			0.14	Other Cut. possible large feature or spread, continues beyond trench		
4622	Fill	4621		0.14	Other Fill. mid to dark brownish grey		
<b>Trench 47</b>							
General description						Orientation	NNE-SSW
Consists of ploughsoil overlying natural geology of sands and gravels.  Trench 47 contained a large pottery kiln (Group 4704) at the southern end, a single pit (4709), a NW-SE aligned ditch (4702) and an east-west aligned ditch (4707).						Length (m)	30
						Width (m)	2
						Avg. depth (m)	0.38
Context No.	Type	Fill Of	Width (m)	Depth (m)	Description	Finds	Date
4700	Layer			0.38	Ploughsoil. Mid-dark brownish grey, clayey silt	Fired clay	
4701	Layer				Natural. Light orangey brown, clayey sand and gravels		
4702	Cut		0.94	0.22	Ditch. Linear NW-SE		
4703	Fill	4702	0.94	0.22	Secondary Fill. Mid to dark brownish grey, sandy silt	Pottery (21)	AD 250-410
4704	Group		5.2		Kiln		
4705	Unexcavated feature		2.2		Other Cut. Kiln, dark grey centre ringed by red, brownish yellow and dark grey, clayey sand	Pottery (54), fired clay	AD 120-410
4706	Fill	4712	3.2	0.26	Deliberate Backfill. Rake out, dark grey, clayey sand	Pottery (199), fired clay	AD 100-410
4707	Cut		0.68	0.16	Ditch		
4708	Fill	4707	0.68	0.16	Secondary Fill. Dark brownish grey, clayey sand	Pottery (593), fired clay	AD 200-300
4709	Cut		1.26	0.29	Pit		
4710	Fill	4709	1.26	0.2	Secondary Fill. Dark brownish grey, clayey sand	Pottery (207)	AD 200-410

4711	Fill	4709	0.97	0.08	Other Fill. Light-mid yellowish brown, sandy clay		
4712	Cut		0.46	0.54	Other Cut. Rake-out		
4713	Fill	4712	0.46	0.54	Deliberate Backfill. Dark mottled orange brown sandy clay with occasional stone inclusions.	Pottery (21), fired clay	AD 250-410
<b>Trench 48</b>							
General description						Orientation	NW-SE
Consists of ploughsoil and subsoil overlying natural geology of silty sand with gravels  Trench 48 contained two ditches (4805, 4803) and a possible pit or ditch terminus (4807). Ditches 4803 and 4805 match the alignment and position of linear features recorded as cropmarks.						Length (m)	30
						Width (m)	2
						Avg. depth (m)	0.45
Context No.	Type	Fill Of	Width (m)	Depth (m)	Description	Finds	Date
4800	Layer			0.25	Ploughsoil. Mid grey brown silty clay		
4801	Layer			0.2	Subsoil. Light orange brown silty sand with frequent gravels		
4802	Layer				Natural. Mixed mid yellow brown and mid orange brown silty sand with gravels		
4803	Cut		0.8	0.22	Ditch. Linear NE-SW		
4804	Fill	4803	0.8	0.22	Secondary Fill. Mid to dark orange brown, sandy silt		
4805	Cut		1.12	0.36	Ditch. Linear N-S		
4806	Fill	4805	1.12	0.36	Secondary Fill. Mid to dark orange brown, sandy silt		
4807	Cut				Ditch. Linear NW-SE		
4808	Fill	4807	0.84	0.28	Primary Fill. Light greyish brown, sandy silt		

Trench 49							
General description					Orientation		N-S
Consists of ploughsoil overlying the natural geology.  Trench 49 contained three ditches (4900, 4901, 4904) and all three match the alignment and position of linear features recorded as cropmarks.					Length (m)		30
					Width (m)		2
					Avg. depth (m)		0.6
Context No.	Type	Fill Of	Width (m)	Depth (m)	Description	Finds	Date
4900	Cut		0.45	0.16	Ditch. Linear NE-SW		
4901	Cut		0.8	0.32	Ditch. Linear NW-SE		
4902	Fill	4900	0.45	0.16	Primary Fill. Light brown grey silty sand		
4903	Fill	4901	0.8	0.32	Primary Fill. Mid grey brown with light yellow patches, silty sand		
4904	Cut		0.47	0.15	Ditch. Linear E-W		
4905	Fill	4904	0.47	0.15	Primary Fill. Mid grey brown silty sand		
4906	Layer				Natural. Mid brownish orange and light yellow silty sand with patches of gravel		
4907	Layer			0.6	Ploughsoil. Mid brown sandy silt		
Trench 50							
General description					Orientation		E-W
Consists of ploughsoil and subsoil overlying the natural geology.  Trench 50 contained multiple NNW-SSE aligned linear ditches (5003, 5005, 5007, 5009, 5011).					Length (m)		30
					Width (m)		2
					Avg. depth (m)		0.5
Context No.	Type	Fill Of	Width (m)	Depth (m)	Description	Finds	Date

5000	Layer			0.32	Ploughsoil. Dark grey brown, silty clay		
5001	Layer			0.18	Subsoil. Mid brown, sandy silt		
5002	Layer				Natural. Light orangey/red yellow, silty sand and gravel		
5003	Cut		1.18	0.52	Ditch. Linear ditch		
5004	Fill	5003	1.18	0.52	Primary Fill. Mid grey brown, sandy silt		
5005	Cut		1.12	0.28	Ditch. Linear ditch, recut of 5003		
5006	Fill	5005	1.12	0.28	Tertiary Fill. Dark grey black, silty sand	Glass	Post-medieval
5007	Cut		1.6	0.5	Ditch		
5008	Fill	5007	1.6	0.5	Primary Fill. Mid greyish brown, silty sand		
5009	Cut		2	0.52	Ditch		
5010	Fill	5009	2	0.52	Primary Fill. Light grey brown, sandy silt		
5011	Cut		1.22	0.42	Ditch		
5012	Fill	5011	1.22	0.42	Primary Fill. Light grey brown, sandy silt and frequent gravel		
<b>Trench 51</b>							
General description					Orientation	N-S	
Trench devoid of archaeology. Consists of ploughsoil and subsoil overlying natural geology of silty sand with gravels					Length (m)	30	
					Width (m)	2	
					Avg. depth (m)	0.35	
Context No.	Type	Fill Of	Width (m)	Depth (m)	Description	Finds	Date
5100	Layer			0.23	Ploughsoil. Dark grey brown, silty clay		



5101	Layer			0.12	Subsoil. Mid brown, sandy silt with gravel inclusions		
5102	Layer				Natural. Light greyish brown, silty sand and gravel		
<b>Trench 52</b>							
General description					Orientation		E-W
Trench devoid of archaeology. Consists of ploughsoil and subsoil overlying natural geology of silty sand with gravels					Length (m)		30
					Width (m)		2
					Avg. depth (m)		0.45
Context No.	Type	Fill Of	Width (m)	Depth (m)	Description	Finds	Date
5200	Layer			0.28	Ploughsoil. Dark grey brown, silty clay		
5201	Layer			0.17	Subsoil. Mid brown, sandy silt with gravel inclusions		
5202	Layer				Natural. Light greyish yellow, silty sand and gravel		
<b>Trench 53</b>							
General description					Orientation		N-S
Trench devoid of archaeology. Consists of ploughsoil layer overlying the natural geology of silty sand and gravel.					Length (m)		30
					Width (m)		2
					Avg. depth (m)		0.35
Context No.	Type	Fill Of	Width (m)	Depth (m)	Description	Finds	Date
5300	Layer			0.35	Ploughsoil. Dark grey brown, silty clay		
5301	Layer				Natural. Mid yellow brown, silty sand and gravel		

<b>Trench 54</b>							
General description						Orientation	
						Length (m)	
						Width (m)	
						Avg. depth (m)	
Context No.	Type	Fill Of	Width (m)	Depth (m)	Description	Finds	Date
<b>Trench 55</b>							
General description						Orientation	NE-SW
Consists of ploughsoil and subsoil overlying natural geology. Trench 55 contained three ditches (5507, 5505 and 5503).						Length (m)	30
						Width (m)	2
						Avg. depth (m)	0.52
Context No.	Type	Fill Of	Width (m)	Depth (m)	Description	Finds	Date
5500	Layer			0.31	Ploughsoil. Dark grey brown, silty clay		
5501	Layer			0.17	Subsoil. Mid brown, sandy silt with gravel inclusions		
5502	Layer				Natural. Light greyish yellow, silty sand and gravel		
5503	Cut		0.45	0.24	Ditch		
5504	Fill	5503	0.45	0.24	Primary Fill. Mid grey brown sandy silt		
5505	Cut		0.8	0.25	Ditch. Linear, ditch terminus		
5506	Fill	5505	0.8	0.25	Secondary Fill. Mid greyish brown, silty sand	Glass	Post-medieval

5507	Cut		1.34	0.2	Ditch. Single fill (5508)		
5508	Fill	5507	1.34	0.2	Secondary Fill. Single fill of ditch		
<b>Trench 56</b>							
General description					Orientation		NW-SE
<p>Consists of ploughsoil and subsoil overlying natural geology of silty sand with gravels</p> <p>Trench 56 contained three ditches (5603, 5605 and 5607) and all were on a NE-SW alignment and matched a linear cropmark at this position. These ditches may be a continuation of the southern part of the main enclosure ditch which was also observed in trenches 29 and 30.</p>					Length (m)		30
					Width (m)		2
					Avg. depth (m)		0.55
Context No.	Type	Fill Of	Width (m)	Depth (m)	Description	Finds	Date
5600	Layer			0.3	Ploughsoil. Mid grey brown silty clay		
5601	Layer			0.25	Subsoil. Light orange brown silty sand		
5602	Layer				Natural. Mid orange brown silty sand with gravels		
5603	Cut		0.66	0.21	Ditch. Linear NE-SW		
5604	Fill	5603	0.66	0.22	Secondary Fill. Mid greyish brown, sandy silt		
5605	Cut		0.36	0.15	Ditch		
5606	Fill	5605	0.36	0.15	Secondary Fill. Mid brownish grey slight orange, sandy silt		
5607	Cut		0.71	0.12	Ditch		
5608	Fill	5607	0.71	0.12	Secondary Fill. Light to mid orange brown slight grey, sandy silt		
<b>Trench 57</b>							
General description					Orientation		N-S

<p>Consists of ploughsoil and subsoil, which becomes deeper at the SE end of the trench, overlying natural geology of silty clay.</p> <p>Trench 57 contained four ditches (5703, 5710, 5707, 5708), and a gully (5705). This trench was extended to allow for excavation of ditch 5707.</p>						Length (m)	30
						Width (m)	2
						Avg. depth (m)	0.47
Context No.	Type	Fill Of	Width (m)	Depth (m)	Description	Finds	Date
5700	Layer			0.32	Ploughsoil. Mid grey brown, silt sand, friable		
5701	Layer			0.4	Subsoil. Mid orange brown silty clay, rare natural flint nodules		
5702	Layer				Natural. Dark red brown silty clay		
5703	Cut		1.7	0.37	Ditch		
5704	Fill	5703	1.7	0.37	Secondary Fill. Dark red brown sandy silt		
5705	Cut		0.54	0.12	Ditch		
5706	Fill	5705	0.54	0.12	Secondary Fill. Mid orange grey clay silt		
5707	Cut		2.9	0.26	Ditch. Cut of probable boundary ditch visible in crop marks. Previously recorded as unexcavated feature. Further machine excavation revealed the ditch clearly allowing for hand excavation.	CBM	
5708	Cut		1.48	0.32	Ditch		
5709	Fill	5708	1.48	0.32	Secondary Fill. Light grey brown silty sand		
5710	Cut		4.67	0.5	Ditch. Linear E-W, Not fully excavated.		
5711	Fill	5710	1.6	0.4	Secondary Fill. Same as 5713. Light yellowish brown silty sand, rare gravel inclusion, frequent pot.		
5712	Fill	5710	4.67	0.4	Secondary Fill. Mid greyish brown silty sand with rare inclusion and frequent pot.		
5713	Fill	5710	1	0.2	Primary Fill. Same as 5711 Mid yellowish brown silty sand, rare gravel inclusion, frequent pot.		

5714	Fill	5707	2.9	0.26	Primary Fill. Light grey brown, silty sand	Pottery (18), CBM	AD 120-410
<b>Trench 58</b>							
General description					Orientation		NE-SW
Consists of ploughsoil overlying natural geology of silty sand.  Trench 58 contained two ditches (5802, 5806) and a tree throw (5804). Both ditches were aligned NW-SE and match the alignment and approximate position of a linear feature recorded as a cropmark					Length (m)		30
					Width (m)		2
					Avg. depth (m)		0.33
Context No.	Type	Fill Of	Width (m)	Depth (m)	Description	Finds	Date
5800	Layer			0.26	Ploughsoil. Dark grey silty clay		
5801	Layer			0.07	Natural. Mid orange silty sand, frequent gravel inclusions		
5802	Cut		1.64	0.28	Ditch. Linear NW-SE		
5803	Fill	5802	1.64	0.28	Secondary Fill. Dark greyish brown, silt, friable		
5804	Cut		0.34	0.24	Tree Throw. Irregular tree throw		
5805	Fill	5804	0.34	0.24	Secondary Fill. From dark yellowish brown to greyish silty sand, friable		
5806	Cut		1.12	0.44	Ditch. Linear E-W		
5807	Fill	5806	1.12	0.44	Secondary Fill. Light yellowish brown, silty fine sand		
<b>Trench 59</b>							
General description					Orientation		NW-SE
Trench devoid of archaeology. Consists of ploughsoil overlying natural geology of silty sand with gravels.					Length (m)		30
					Width (m)		2

						Avg. depth (m)	0.3
Context No.	Type	Fill Of	Width (m)	Depth (m)	Description	Finds	Date
5900	Layer			0.3	Ploughsoil. Mid grey brown silty clay		
5901	Layer				Natural. Mid orange brown silty sand with gravels.		
<b>Trench 60</b>							
General description						Orientation	NE-SW
Consists of ploughsoil and subsoil overlying natural geology of silty sand.  Trench 60 contained a small ditch or natural feature (6003) aligned NE-SW						Length (m)	30
						Width (m)	2
						Avg. depth (m)	0.43
Context No.	Type	Fill Of	Width (m)	Depth (m)	Description	Finds	Date
6000	Layer			0.27	Ploughsoil. Dark grey brown, silty clay		
6001	Layer			0.16	Subsoil. Mid brown, sandy silt		
6002	Layer				Natural. Light orangey/red yellow, silty sand and gravel		
6003	Cut		0.96	0.2	Natural Feature		
6004	Fill	6003	0.96	0.2	Other Fill. Mid brownish Red silty clay, compact		
<b>Trench 61</b>							
General description						Orientation	NE-SW
Consists of ploughsoil and subsoil overlying natural geology of silty sand with gravels  Trench 61 contained two ditches (6103, 6108) and a pit (6104). All three matched the alignment and position of linear cropmarks						Length (m)	30
						Width (m)	2

recorded at this location although ditch 6103 appears to continue further south-east than the recorded cropmark.					Avg. depth (m)	0.5	
Context No.	Type	Fill Of	Width (m)	Depth (m)	Description	Finds	Date
6100	Layer			0.3	Ploughsoil. Mid grey brown silty clay		
6101	Layer			0.2	Subsoil. Mid orange brown silty sand with gravels		
6102	Layer				Natural. Mixed mid yellow brown and mid orange brown silty sand with gravels		
6103	Cut		0.82	0.17	Ditch		
6104	Cut		0.57	0.25	Pit		
6105	Fill	6103	0.82	0.17	Secondary Fill. Mid orange brown, sandy silt		
6106	Fill	6104	0.54	0.1	Secondary Fill. Mid greyish brown, silty sand		
6107	Fill	6104	0.56	0.14	Secondary Fill. Mid orange brown, silty clay		
6108	Cut		0.52	0.18	Ditch. Linear		
6109	Fill	6108	0.52	0.18	Secondary Fill. Mid orange brown, silty sand		
<b>Trench 62</b>							
General description					Orientation	NE-SW	
Trench devoid of archaeology. Consists of ploughsoil and subsoil overlying natural geology of gravely sand and silt patches.					Length (m)	30	
					Width (m)	2	
					Avg. depth (m)	0.51	
Context No.	Type	Fill Of	Width (m)	Depth (m)	Description	Finds	Date
6200	Layer			0.29	Ploughsoil. Mid brown sandy silt		
6201	Layer			0.22	Subsoil. Mid brown orange. Silty sand.		

6202	Layer				Natural. Mid orange gravely sand and silt patches.		
<b>Trench 63</b>							
General description					Orientation	E-W	
Trench devoid of archaeology. Consists of ploughsoil and subsoil overlying natural geology of silty sand.					Length (m)	30	
					Width (m)	2	
					Avg. depth (m)	0.52	
Context No.	Type	Fill Of	Width (m)	Depth (m)	Description	Finds	Date
6300	Layer			0.3	Ploughsoil. Dark grey brown, silty clay		
6301	Layer			0.22	Subsoil. Mid brown, sandy silt		
6302	Layer				Natural. Light orangey/red yellow, silty sand with frequent gravel patches		
6303	Cut		1.42	0.45	Tree Throw		
6304	Fill	6303	1.42	0.45	Primary Fill. Light yellowish grey, sandy silt		
<b>Trench 64</b>							
General description					Orientation	N-S	
Trench devoid of archaeology. Consists of ploughsoil and subsoil overlying natural geology of silty sand.					Length (m)	30	
					Width (m)	2	
					Avg. depth (m)	0.46	
Context No.	Type	Fill Of	Width (m)	Depth (m)	Description	Finds	Date
6400	Layer			0.3	Ploughsoil. Dark brown grey, silty clay		



6401	Layer			0.16	Subsoil. Mid orangey brown, sandy silt		
6402	Layer				Natural. Mid brownish orange, silty sand with gravel patches		
<b>Trench 65</b>							
General description					Orientation		E-W
Trench devoid of archaeology. Consists of ploughsoil and subsoil layer overlying the natural geology of silty sand and gravel.					Length (m)		30
					Width (m)		2
					Avg. depth (m)		0.46
Context No.	Type	Fill Of	Width (m)	Depth (m)	Description	Finds	Date
6500	Layer			0.3	Ploughsoil. Dark grey brown, silty clay		
6501	Layer			0.16	Subsoil. Mid orangey brown, sandy silt		
6502	Layer				Natural. Mid yellow brown, silty sand and gravel		
<b>Trench 66</b>							
General description					Orientation		NE-SW
Trench devoid of archaeology. Consists of ploughsoil overlying natural geology of silty sand with gravels.					Length (m)		30
					Width (m)		2
					Avg. depth (m)		0.5
Context No.	Type	Fill Of	Width (m)	Depth (m)	Description	Finds	Date
6600	Layer			0.5	Ploughsoil. Mid grey brown silty clay		
6601	Layer				Natural. Mid orange brown silty sand with gravels		

<b>Trench 67</b>							
General description						Orientation	NE-SW
Trench devoid of archaeology. Consists of ploughsoil overlying natural geology of silty sand with gravels.						Length (m)	30
						Width (m)	2
						Avg. depth (m)	0.3
Context No.	Type	Fill Of	Width (m)	Depth (m)	Description	Finds	Date
6700	Layer			0.3	Ploughsoil. Mid grey brown silty clay		
6701	Layer				Natural. Mid orange brown silty sand with gravels		
<b>Trench 68</b>							
General description						Orientation	NW-SE
Trench devoid of archaeology. Consists of ploughsoil overlying natural geology of silty sand with gravels.						Length (m)	30
						Width (m)	2
						Avg. depth (m)	0.3
Context No.	Type	Fill Of	Width (m)	Depth (m)	Description	Finds	Date
6800	Layer			0.3	Ploughsoil. Mid grey brown silty clay		
6801	Layer				Natural. Mid orange brown silty sand with occasional gravels.		
<b>Trench 69</b>							
General description						Orientation	E-W

Trench devoid of archaeology. Consists of ploughsoil overlying natural geology of silty sand with gravels.						Length (m)	30
						Width (m)	2
						Avg. depth (m)	0.4
Context No.	Type	Fill Of	Width (m)	Depth (m)	Description	Finds	Date
6900	Layer			0.3	Ploughsoil. Mid grey brown silty clay		
6901	Layer				Natural. Mid orange brown silty sand with gravels		
<b>Trench 70</b>							
General description						Orientation	NE-SW
Trench 70 contained a possible ditch terminus (7003). Consisted of ploughsoil and subsoil layer overlying the natural geology of silty sand with gravel patches.						Length (m)	30
						Width (m)	2
						Avg. depth (m)	0.39
Context No.	Type	Fill Of	Width (m)	Depth (m)	Description	Finds	Date
7000	Layer			0.29	Ploughsoil. Dark grey brown, silty clay		
7001	Layer			0.1	Subsoil. Mid orangey brown, sandy silt		
7002	Layer				Natural. Mid red brown, silty sand with gravel patches		
7003	Cut		0.96	0.33	Ditch		
7004	Fill	7003	0.86	0.13	Secondary Fill. Mid orangey brown, sandy silt		
7005	Fill	7003	0.82	0.25	Deliberate Backfill. Dark blackish brown, sandy silt		
<b>Trench 71</b>							

General description						Orientation	E-W
Trench devoid of archaeology. Consists of ploughsoil and subsoil layer overlying the natural geology of silty sand with gravel patches.						Length (m)	30
						Width (m)	2
						Avg. depth (m)	0.35
Context No.	Type	Fill Of	Width (m)	Depth (m)	Description	Finds	Date
7100	Layer			0.28	Ploughsoil. Dark grey brown, silty clay		
7101	Layer			0.07	Subsoil. Mid orangey brown, sandy silt		
7102	Layer				Natural. Mid red brown, silty sand with gravel patches		
<b>Trench 72</b>							
General description						Orientation	N-S
Trench devoid of archaeology. Consists of ploughsoil and subsoil layer overlying the natural geology of silty sand with gravel patches.						Length (m)	30
						Width (m)	2
						Avg. depth (m)	0.42
Context No.	Type	Fill Of	Width (m)	Depth (m)	Description	Finds	Date
7200	Layer			0.31	Ploughsoil. Dark grey brown, silty clay		
7201	Layer			0.11	Subsoil. Mid orangey brown, sandy silt		
7202	Layer				Natural. Mid red brown, silty sand with gravel patches		
<b>Trench 73</b>							
General description						Orientation	E-W

Trench devoid of archaeology. Consists of ploughsoil and subsoil layer overlying the natural geology of silty sand.						Length (m)	30
						Width (m)	2
						Avg. depth (m)	0.4
Context No.	Type	Fill Of	Width (m)	Depth (m)	Description	Finds	Date
7300	Layer			0.28	Ploughsoil. Dark grey brown, silty clay		
7301	Layer			0.12	Subsoil. Mid orangey brown, sandy silt		
7302	Layer				Natural. Mid red brown, silty sand. Plough scars visible		
<b>Trench 74</b>							
General description						Orientation	N-S
Trench showing one ditch (7403). Consisted of ploughsoil and subsoil layer overlying the natural geology of silty sand and gravel.						Length (m)	30
						Width (m)	2
						Avg. depth (m)	0.43
Context No.	Type	Fill Of	Width (m)	Depth (m)	Description	Finds	Date
7400	Layer			0.29	Ploughsoil. Dark grey brown, silty clay		
7401	Layer			0.14	Subsoil. Mid orangey brown, sandy silt		
7402	Layer				Natural. Mid red brown, silty sand with gravel patches		
7403	Cut		1.52	0.52	Ditch		
7404	Fill	7403	1.52	0.52	Secondary Fill. Mid and light orangey brown, sandy silt	Glass	late 19th-century or early 20th-century
<b>Trench 75</b>							

General description					Orientation	NW-SE	
Trench devoid of archaeology. Consists of natural geology of silty sand with gravels.					Length (m)	30	
					Width (m)	2	
					Avg. depth (m)	0.3	
Context No.	Type	Fill Of	Width (m)	Depth (m)	Description	Finds	Date
7500	Layer			0.3	Ploughsoil. Mid grey brown silty clay		
7501	Layer				Natural. Mid orange brown silty sand with gravels		
<b>Trench 76</b>							
General description					Orientation	N-S	
Consists of ploughsoil overlying natural geology of silty sand and gravels.  Trench 76 contained an ENE-WSW aligned ditch (7602), a tree throw (7604) and a modern feature (7606) which was unexcavated					Length (m)	30	
					Width (m)	2	
					Avg. depth (m)	0.4	
Context No.	Type	Fill Of	Width (m)	Depth (m)	Description	Finds	Date
7600	Layer			0.4	Ploughsoil. Mid grey brown silty clay		
7601	Layer				Natural. Mid orange brown silty sand with gravels.		
7602	Cut		1.62	0.4	Ditch		
7603	Fill	7602	1.62	0.4	Secondary Fill. Mid to dark greyish brown, sandy silt		
7604	Cut		1.56		Natural Feature. Tree bowl		
7605	Fill	7604	1.56		Secondary Fill. Mid brownish grey patches of very dark grey, silt		
7606	Unexcavated feature		0.26		Modern. Dark grey, sandy silt, modern glass visible in plan		

<b>Trench 77</b>							
General description						Orientation	E-W
Trench devoid of archaeology. Consists of Ploughsoil overlying natural geology of silty sand with gravels.						Length (m)	30
						Width (m)	2
						Avg. depth (m)	0.35
Context No.	Type	Fill Of	Width (m)	Depth (m)	Description	Finds	Date
7700	Layer			0.35	Ploughsoil. Mid grey brown silty clay		
7701	Layer				Natural. Mid orange brown silty sand with gravels.		
<b>Trench 78</b>							
General description						Orientation	NW-SE
Trench revealed two linear features, a tree throw and a modern feature at the E end. Consists of ploughsoil overlying the natural geology of silty sand with gravels.						Length (m)	30
						Width (m)	2
						Avg. depth (m)	0.31
Context No.	Type	Fill Of	Width (m)	Depth (m)	Description	Finds	Date
7800	Layer			0.31	Ploughsoil. Dark grey brown, silty clay		
7801	Layer				Natural. Mid red and yellowish brown, silty sand with gravels		
7802	Cut		1.32	0.36	Ditch		
7803	Fill	7802	1.32	0.36	Secondary Fill. Mid orangey brown, sandy silt		
7804	Unexcavated feature		2.72		Modern. Mid brownish grey, silty sand		

7805	Cut		2.09	0.57	Ditch		
7806	Fill	7805	2.09	0.57	Secondary Fill. Light-mid greyish brown, silty sand	Pottery (1), fired clay	Late Bronze Age
7807	Cut		3.16	0.24	Tree Throw		
7808	Fill	7807	3.16	0.24	Secondary Fill. Mid-dark greyish brown, silty sand		
<b>Trench 79</b>							
General description						Orientation	NE-SW
Trench revealing two ditches (7903, 7906). Consisted of ploughsoil and subsoil layers overlying the natural geology of silty sand with gravel patches.						Length (m)	30
						Width (m)	2
						Avg. depth (m)	0.5
Context No.	Type	Fill Of	Width (m)	Depth (m)	Description	Finds	Date
7900	Layer			0.37	Ploughsoil. Dark grey brown, silty clay		
7901	Layer			0.13	Subsoil. Mid orangey brown, sandy silt		
7902	Layer				Natural. Mid red brown, silty sand with gravel patches		
7903	Cut		1.68	0.62	Ditch		
7904	Fill	7903	1.16	0.26	Primary Fill. Dark grey brown, silty sand		
7905	Fill	7903	1.68	0.38	Secondary Fill. Mid greyish brown, silty sand	Glass	Mid-18th century
7906	Unexcavated feature		1.33		Modern. Linear ditch, E-W, modern. Same as ditch in tr. 74 and 80. Visible on 19h century historic maps. Possible old boundary.		
<b>Trench 80</b>							



General description					Orientation	N-S	
Trench revealed a ditch (8003). Consisted of ploughsoil and subsoil overlying the natural geology of silty sand					Length (m)	17	
					Width (m)	2	
					Avg. depth (m)	0.45	
Context No.	Type	Fill Of	Width (m)	Depth (m)	Description	Finds	Date
8000	Layer			0.31	Ploughsoil. Dark grey brown, silty clay		
8001	Layer			0.15	Subsoil. Mid orangey brown, sandy silt		
8002	Layer				Natural. Mid red brown, silty sand with occasional gravel		
8003	Cut		1.91	0.65	Ditch		
8004	Fill	8003	0.92	0.25	Secondary Fill. Dark grey brown, silty sand	Clay pipe	c 1840-1910
8005	Fill	8003	1.91	0.41	Secondary Fill. Mid orange brown, silty sand	CBM	16th-19th century
<b>Trench 81</b>							
General description					Orientation	E-W	
Trench devoid of archaeology. Consists of ploughsoil overlying the natural geology of silty sand with gravel patches.					Length (m)	30	
					Width (m)	2	
					Avg. depth (m)	0.35	
Context No.	Type	Fill Of	Width (m)	Depth (m)	Description	Finds	Date
8100	Layer			0.35	Ploughsoil. Dark grey brown, silty clay		
8101	Layer				Natural. Mid red brown, silty sand with gravel patches		

<b>Trench 82</b>							
General description					Orientation		E-W
Trench devoid of any archaeology. Consists of ploughsoil overlying natural geology of silty sand with gravels.					Length (m)		18
					Width (m)		10.2
					Avg. depth (m)		0.4
Context No.	Type	Fill Of	Width (m)	Depth (m)	Description	Finds	Date
8200	Layer			0.4	Ploughsoil. Mid grey brown silty clay		
8201	Layer				Natural. Mid orange brown silty sand with gravels		
<b>Trench 83</b>							
General description					Orientation		NE-SW
Trench devoid of archaeology. Consists of ploughsoil overlying natural geology of silty sand.					Length (m)		30
					Width (m)		2
					Avg. depth (m)		0.3
Context No.	Type	Fill Of	Width (m)	Depth (m)	Description	Finds	Date
8300	Layer			0.3	Ploughsoil. Mid grey brown silty clay		
8301	Layer				Natural. Mid orange brown silty sand		
<b>Trench 84</b>							
General description					Orientation		NE-SW
Trench devoid of archaeology. Consists of ploughsoil overlying natural geology of silty sand.					Length (m)		30

						Width (m)	2
						Avg. depth (m)	0.3
Context No.	Type	Fill Of	Width (m)	Depth (m)	Description	Finds	Date
8400	Layer			0.3	Ploughsoil. Mid grey brown silty clay		
8401	Layer				Natural. Mid orange brown silty sand.		
<b>Trench 85</b>							
General description						Orientation	NW-SE
Trench devoid of archaeology. Consists of ploughsoil overlying natural geology of silty sand.						Length (m)	30
						Width (m)	2
						Avg. depth (m)	0.3
Context No.	Type	Fill Of	Width (m)	Depth (m)	Description	Finds	Date
8500	Layer			0.3	Ploughsoil. Mid grey brown silty clay		
8501	Layer				Natural. Mid orange brown silty sand		
<b>Trench 86</b>							
General description						Orientation	NE-SW
Trench devoid of archaeology. Consists of ploughsoil overlying natural geology of silty sand with gravels.						Length (m)	30
						Width (m)	2
						Avg. depth (m)	0.3
Context No.	Type	Fill Of	Width (m)	Depth (m)	Description	Finds	Date

8600	Layer			0.3	Ploughsoil. Mid grey brown silty clay		
8601	Layer				Natural. Mixed mid orange brown and mid yellow brown silty sand with gravels		
<b>Trench 87</b>							
General description					Orientation		NW-SE
Trench devoid of archaeology. Consists of ploughsoil overlying natural geology of silty sand with occasional gravels.					Length (m)		30
					Width (m)		2
					Avg. depth (m)		0.35
Context No.	Type	Fill Of	Width (m)	Depth (m)	Description	Finds	Date
8700	Layer			0.35	Ploughsoil. Mid grey brown silty clay		
8701	Layer				Natural. Mid yellow brown silty sand with occasional gravels		
<b>Trench 88</b>							
General description					Orientation		E-W
Trench devoid of archaeology. Consists of ploughsoil overlying natural geology of silty sand with occasional gravels.					Length (m)		30
					Width (m)		2
					Avg. depth (m)		0.34
Context No.	Type	Fill Of	Width (m)	Depth (m)	Description	Finds	Date
8800	Layer			0.34	Ploughsoil. Mid grey brown silty clay		
8801	Layer				Natural. Mid orange brown silty sand with occasional gravels		

<b>Trench 89</b>							
General description					Orientation		N-S
Trench devoid of archaeology. Consists of ploughsoil overlying natural geology of silty sand with occasional gravels					Length (m)		30
					Width (m)		2
					Avg. depth (m)		0.3
Context No.	Type	Fill Of	Width (m)	Depth (m)	Description	Finds	Date
8900	Layer			0.3	Ploughsoil. Mid grey brown silty clay		
8901	Layer				Natural. Mid orange brown silty sand with occasional gravels		
<b>Trench 90</b>							
General description					Orientation		E-W
Trench devoid of archaeology. Consists of ploughsoil overlying natural geology of silty sand with occasional gravels					Length (m)		30
					Width (m)		2
					Avg. depth (m)		0.27
Context No.	Type	Fill Of	Width (m)	Depth (m)	Description	Finds	Date
9000	Layer			0.27	Ploughsoil. Mid grey brown silty clay		
9001	Layer				Natural. Mid orange brown silty sand with occasional gravels.		
<b>Trench 91</b>							
General description					Orientation		N-S
Trench devoid of archaeology. Consists of ploughsoil overlying natural geology of silty sand with occasional gravels.					Length (m)		30

						Width (m)	2
						Avg. depth (m)	0.3
Context No.	Type	Fill Of	Width (m)	Depth (m)	Description	Finds	Date
9100	Layer			0.3	Ploughsoil. Mid grey brown silty clay		
9101	Layer				Natural. Mid orange brown silty sand with occasional gravels		
<b>Trench 92</b>							
General description						Orientation	NW-SE
Consists of ploughsoil and subsoil overlying natural geology of silty sand with gravels. Trench 92 contained two ditches (9203, 9205) and both were aligned roughly north-south.						Length (m)	30
						Width (m)	2
						Avg. depth (m)	0.42
Context No.	Type	Fill Of	Width (m)	Depth (m)	Description	Finds	Date
9200	Layer			0.3	Ploughsoil. Mid grey brown, sandy silt		
9201	Layer			0.12	Subsoil. Mid orange brown, silt sand		
9202	Layer				Natural. Mid brownish orange, silt sand, with gravel inclusions		
9203	Cut		2.04	0.5	Ditch		
9204	Fill	9203	0.81	0.16	Secondary Fill. Mid orange brown silty sand		
9205	Cut		0.82	0.31	Ditch		
9206	Fill	9205	0.81	0.31	Primary Fill. Mid grey brown silty sand		
9207	Fill	9203	2.04	0.5	Primary Fill. Light brown grey silty sand, occasional charcoal flecks		

<b>Trench 93</b>							
General description					Orientation		NW-SE
Trench devoid of archaeology. Consists of ploughsoil overlying natural geology of silty sand.					Length (m)		30
					Width (m)		2
					Avg. depth (m)		0.3
Context No.	Type	Fill Of	Width (m)	Depth (m)	Description	Finds	Date
9300	Layer			0.3	Ploughsoil. Mid grey brown silty clay		
9301	Layer				Natural. Mid orange brown silty sand		
<b>Trench 94</b>							
General description					Orientation		NE-SW
Trench devoid of archaeology. Consists of ploughsoil and subsoil overlying natural geology of silty sand					Length (m)		30
					Width (m)		2
					Avg. depth (m)		0.45
Context No.	Type	Fill Of	Width (m)	Depth (m)	Description	Finds	Date
9400	Layer			0.35	Ploughsoil. Mid grey brown silty clay		
9401	Layer			0.1	Subsoil. Mid yellow brown silty sand		
9402	Layer				Natural. Mid orange brown silty sand		
<b>Trench 95</b>							
General description					Orientation		N-S

Trench devoid of archaeology. Consisted of ploughsoil and subsoil layers overlying the natural geology of silty sand.						Length (m)	30
						Width (m)	2
						Avg. depth (m)	0.43
Context No.	Type	Fill Of	Width (m)	Depth (m)	Description	Finds	Date
9500	Layer			0.31	Ploughsoil. Dark grey brown, silty clay		
9501	Layer			0.12	Subsoil. Mid orangey brown, sandy silt		
9502	Layer				Natural. Mid red brown, silty sand		
<b>Trench 96</b>							
General description						Orientation	NW-SE
Trench devoid of archaeology. Consists of ploughsoil and subsoil overlying natural geology of silty sand with gravels						Length (m)	30
						Width (m)	2
						Avg. depth (m)	0.55
Context No.	Type	Fill Of	Width (m)	Depth (m)	Description	Finds	Date
9600	Layer			0.35	Ploughsoil. Mid grey brown silty clay		
9601	Layer			0.2	Subsoil. Light yellow brown silty sand		
9602	Layer				Natural. Mid orange brown silty sand with gravels		
<b>Trench 97</b>							
General description						Orientation	N-S
Trench devoid of archaeology. Consists of ploughsoil and subsoil layers overlying the natural geology of silty sand.						Length (m)	30



						Width (m)	2
						Avg. depth (m)	0.36
Context No.	Type	Fill Of	Width (m)	Depth (m)	Description	Finds	Date
9700	Layer			0.28	Ploughsoil. Dark grey brown, silty clay		
9701	Layer			0.08	Subsoil. Mid orangey brown, sandy silt		
9702	Layer				Natural. Mid red and yellowish brown, silty sand		
<b>Trench 98</b>							
General description						Orientation	E-W
Consisted of ploughsoil and subsoil layers overlying the natural geology of silty sand.  Trench 98 contained one ditch (9807) on an NNE-SSW alignment						Length (m)	30
						Width (m)	2
						Avg. depth (m)	0.36
Context No.	Type	Fill Of	Width (m)	Depth (m)	Description	Finds	Date
9800	Layer			0.26	Ploughsoil. Dark grey brown, silty clay		
9801	Layer			0.1	Subsoil. Mid orangey brown, sandy silt		
9802	Layer				Natural. Mid red yellowish brown, silty sand		
9803	Void						
9804	Void						
9805	Void						
9806	Void						
9807	Cut		1.26	0.55	Ditch		

9808	Fill	9807	1.26	0.55	Primary Fill. Mid grey brown silty sand	Pottery (1)	Roman
<b>Trench 99</b>							
General description					Orientation		N-S
Trench devoid of archaeology. Consists of ploughsoil overlying natural geology of silty sand with occasional gravels.					Length (m)		30
					Width (m)		2
					Avg. depth (m)		0.35
Context No.	Type	Fill Of	Width (m)	Depth (m)	Description	Finds	Date
9900	Layer			0.35	Ploughsoil. Mid grey brown silty clay		
9901	Layer				Natural. Mid orange brown silty sand with occasional gravels		
<b>Trench 100</b>							
General description					Orientation		NW-SE
Trench devoid of archaeology. Consists of ploughsoil overlying natural geology of silty sand with gravels					Length (m)		30
					Width (m)		2
					Avg. depth (m)		0.3
Context No.	Type	Fill Of	Width (m)	Depth (m)	Description	Finds	Date
10000	Layer			0.3	Ploughsoil. Mid grey brown silty clay		
10001	Layer				Natural. Mid orange brown silty sand		
<b>Trench 101</b>							

General description						Orientation	NW-SE
Trench devoid of archaeology. Consists of ploughsoil and subsoil overlying natural geology of silty sand						Length (m)	30
						Width (m)	2
						Avg. depth (m)	0.58
Context No.	Type	Fill Of	Width (m)	Depth (m)	Description	Finds	Date
10100	Layer			0.3	Ploughsoil. Mid grey brown silty clay		
10101	Layer			0.28	Subsoil. Light yellow brown silty sand		
10102	Layer				Natural. Mid orange brown silty sand		
<b>Trench 102</b>							
General description						Orientation	NE-SW
Trench devoid of archaeology. Consists of ploughsoil and subsoil overlying natural geology of silty sand						Length (m)	30
						Width (m)	2
						Avg. depth (m)	0.6
Context No.	Type	Fill Of	Width (m)	Depth (m)	Description	Finds	Date
10200	Layer			0.3	Ploughsoil. Mid grey brown silty clay		
10201	Layer			0.3	Subsoil. Light yellow brown silty sand		
10202	Layer				Natural. Mid orange brown silty sand		
<b>Trench 103</b>							
General description						Orientation	NW-SE

Trench devoid of archaeology. Consists of ploughsoil overlying natural geology of silty sand with gravels.						Length (m)	30
						Width (m)	2
						Avg. depth (m)	0.4
Context No.	Type	Fill Of	Width (m)	Depth (m)	Description	Finds	Date
10300	Layer			0.4	Ploughsoil. Mid grey brown silty clay		
10301	Layer				Natural. Mid orange brown silty sand		
<b>Trench 104</b>							
General description						Orientation	NE-SW
Trench devoid of archaeology. Consists of ploughsoil overlying natural geology of silty sand with gravels						Length (m)	30
						Width (m)	2
						Avg. depth (m)	0.3
Context No.	Type	Fill Of	Width (m)	Depth (m)	Description	Finds	Date
10400	Layer			0.3	Ploughsoil. Mid grey brown silty clay		
10401	Layer				Natural. Mid orange brown silty sand		
<b>Trench 105</b>							
General description						Orientation	NW-SE
Trench devoid of archaeology. Consists of ploughsoil overlying natural geology of silty sand with gravels						Length (m)	30
						Width (m)	2
						Avg. depth (m)	0.4

Context No.	Type	Fill Of	Width (m)	Depth (m)	Description	Finds	Date
10500	Layer			0.4	Ploughsoil. Mid grey brown silty clay		
10501	Layer				Natural. Mid orange brown silty sand with gravels		
<b>Trench 106</b>							
General description					Orientation		NE-SW
Trench devoid of archaeology. Consists of ploughsoil and subsoil overlying natural geology of silty sand					Length (m)		30
					Width (m)		2
					Avg. depth (m)		0.5
Context No.	Type	Fill Of	Width (m)	Depth (m)	Description	Finds	Date
10600	Layer			0.32	Ploughsoil. Mid brown silty clay		
10601	Layer			0.18	Subsoil. Mid orange brown sandy silt.		
10602	Layer				Natural. Mid orange brown silty with gravels.		
<b>Trench 107</b>							
General description					Orientation		NE-SW
Trench contains a single NW-SE aligned ditch at the southern end of the trench. Consists of ploughsoil and subsoil overlying natural geology of silty sand.					Length (m)		30
					Width (m)		2
					Avg. depth (m)		0.49
Context No.	Type	Fill Of	Width (m)	Depth (m)	Description	Finds	Date
10700	Layer			0.3	Topsoil. Mid grey brown, silty sand		

10701	Layer			0.19	Subsoil. Mid yellow brown, silty sand		
10702	Layer				Natural. Mid brown yellow, silty sand		
10703	Cut		0.86	0.2	Ditch		
10704	Fill	10703	0.86	0.2	Secondary Fill. Mid orange brown, silty sand		
<b>Trench 108</b>							
General description					Orientation	NW-SE	
Trench devoid of archaeology. Consists of ploughsoil and subsoil overlying natural geology of silty sand with gravels					Length (m)	30	
					Width (m)	2	
					Avg. depth (m)	0.6	
Context No.	Type	Fill Of	Width (m)	Depth (m)	Description	Finds	Date
10800	Layer			0.3	Ploughsoil. Mid grey brown silty clay		
10801	Layer			0.3	Subsoil. Mid orange brown silty clay		
10802	Layer				Natural. Mid orange brown silty sand with occasional gravels		
<b>Trench 109</b>							
General description					Orientation	NE-SW	
Consists of ploughsoil and subsoil overlying natural geology silty sand with occasional gravels  Trench 109 contained two ditches (10903, 10905) and both were aligned NW-SE.					Length (m)	30	
					Width (m)	2	
					Avg. depth (m)	0.52	
Context No.	Type	Fill Of	Width (m)	Depth (m)	Description	Finds	Date

10900	Layer			0.28	Topsoil. Mid grey brown, silty sand		
10901	Layer			0.24	Subsoil. Mid yellow brown, silty sand		
10902	Layer				Natural. Mid brown yellow, silty sand		
10903	Cut		1.66	0.26	Ditch		
10904	Fill	10903	1.66	0.26	Secondary Fill. Mid yellowish brown, sandy silt		
10905	Cut		1.66	0.26	Ditch		
10906	Fill	10905	1.66	0.26	Secondary Fill. Mid yellowish brown, sandy silt		
<b>Trench 110</b>							
General description						Orientation	NW-SE
Consists of Ploughsoil and subsoil overlying natural geology of silty sand.  Trench 110 contained two ditches aligned NW-SE (11003, 11005) although the westerly one appeared to terminate but then continue as another ditch but this may be due to truncation						Length (m)	30
						Width (m)	2
						Avg. depth (m)	0.48
Context No.	Type	Fill Of	Width (m)	Depth (m)	Description	Finds	Date
11000	Layer			0.24	Ploughsoil. Dark greyish brown, clay silt		
11001	Layer			0.24	Subsoil. Mid brownish orange, sandy silt		
11002	Layer				Natural. Mid to dark brownish red, sandy silt		
11003	Cut		1.55	0.24	Ditch		
11004	Fill	11003	1.55	0.24	Secondary Fill. Mid to dark yellowish brown, sandy silt		
11005	Cut		1.55	0.19	Ditch		
11006	Fill	11005	1.55	0.19	Secondary Fill. Mid to dark greyish brown slight yellowish, sandy silt		

11007	Unexcavated feature		1.5		Ditch. Mid to dark greyish brown slight yellowish, sandy silt		
<b>Trench 111</b>							
General description					Orientation	NE-SW	
Consists of ploughsoil overlying natural geology of silty sand  Trench 111 contained two ditches (11103 and 11105) which were both on a NW-SE alignment as with trenches 10903 and 10905 in trench 109.					Length (m)	30	
					Width (m)	2	
					Avg. depth (m)	0.3	
Context No.	Type	Fill Of	Width (m)	Depth (m)	Description	Finds	Date
11100	Layer			0.24	Topsoil. Mid grey brown, silty sand		
11101	Layer			0.06	Subsoil. Mid yellow brown, silty sand		
11102	Layer				Natural. Mid brown yellow, silty sand		
11103	Cut		1.48	0.36	Ditch		
11104	Fill	11103	1.48	0.36	Secondary Fill. Mid yellowish brown, sandy silt	Pottery, fired clay, worked flint	Late Bronze Age/early Iron Age/early prehistoric? (res)
11105	Cut		1.58	0.39	Ditch		
11106	Fill	11105	1.58	0.39	Secondary Fill. Mid yellowish brown, sandy silt		
<b>Trench 112</b>							
General description					Orientation	NW-SE	
Trench devoid of archaeology. Consists of ploughsoil and subsoil overlying natural geology of silty sand.					Length (m)	30	
					Width (m)	2	
					Avg. depth (m)	0.45	



Context No.	Type	Fill Of	Width (m)	Depth (m)	Description	Finds	Date
11200	Layer			0.3	Ploughsoil. Mid grey brown silty clay		
11201	Layer			0.15	Subsoil. Dark orange brown silty clay		
11202	Layer				Natural. Mid orange brown silty sand. Rare gravels		
<b>Trench 113</b>							
General description					Orientation	NE-SW	
<p>Consists of ploughsoil and subsoil overlying natural geology of silty sand with occasional gravels</p> <p>Trench 113 contained two irregular amorphous features (11303 and 11305). Feature 11303 was thought to be a natural feature caused by a depression in the gravel that had silted up. Feature 11305 was thought to be a tree throw 1.36m wide and 0.38m deep containing redeposited natural.</p>					Length (m)	30	
					Width (m)	2	
					Avg. depth (m)	0.5	
Context No.	Type	Fill Of	Width (m)	Depth (m)	Description	Finds	Date
11300	Layer			0.35	Ploughsoil. Mid-dark greyish brown silty sand		
11301	Layer			0.14	Subsoil. Light-mid greyish brown silty sand		
11302	Layer				Natural. Light yellowish/reddish brown silty sand and gravel		
11303	Cut		1.6	0.1	Natural Feature		
11304	Fill	11303	1.6	0.1	Secondary Fill. Soft mid greyish brown silty clay		
11305	Cut		1.36	0.38	Tree Throw		
11306	Fill	11305	1.36	0.38	Secondary Fill. Compact light-mid greyish brown silty sand		
11307	Fill	11305	0.9	0.19	Other Fill. Soft light-mid orangey brown silty sand redeposited natural		
<b>Trench 114</b>							

General description					Orientation	NW-SE	
Consists of ploughsoil and subsoil overlaying natural geology of silty sands.  Trench 114 contained two NNE-SSW aligned ditches (11416, 11408) and four pits (11403, 11406, 11411, 11414).					Length (m)	30	
					Width (m)	2	
					Avg. depth (m)	0.36	
Context No.	Type	Fill Of	Width (m)	Depth (m)	Description	Finds	Date
11400	Layer			0.3	Ploughsoil. Mid-dark greyish brown silty sand		
11401	Layer			0.06	Subsoil. Mid brown silty sand		
11402	Layer				Natural. Light reddish brown silty sand		
11403	Cut		0.52	0.22	Pit		
11404	Fill	11403	0.52	0.2	Secondary Fill. Light greyish brown silty sand		
11405	Fill	11403	0.28	0.04	Secondary Fill. Dark brownish grey silty sand		
11406	Cut		1.18	0.2	Pit		
11407	Fill	11406	1.18	0.2	Secondary Fill. Light greyish brown silty sand		
11408	Cut		1.32	0.49	Ditch		
11409	Fill	11408	1.32	0.33	Secondary Fill. Mid to dark greyish brown, sandy silt		
11410	Fill	11408	1.32	0.16	Secondary Fill. Mid to dark brownish grey with yellowish patches, sandy silt		
11411	Cut		0.7	0.23	Pit		
11412	Fill	11411	0.7	0.15	Secondary Fill. Mid brownish grey silty sand		
11413	Fill	11411	0.7	0.14	Secondary Fill. Light-mid reddish brown silty sand		
11414	Cut		0.46	0.13	Pit		
11415	Fill	11414	0.46	0.13	Secondary Fill. Mid brownish grey silty sand		

11416	Cut		1.68	0.81	Ditch. Possible ring ditch		
11417	Fill	11416	0.75	0.17	Primary Fill. Mid reddish brown silty sand mottled with light grey		
11418	Fill	11416	0.62	0.24	Secondary Fill. Mid greyish brown silty sand with light brown mottling	Worked flint	
11419	Fill	11416	0.8	0.2	Secondary Fill. Mid-dark brownish grey silty sand with light grey mottling	Pottery, Worked flint	Late Bronze Age- early iron Age pottery and later prehistoric flint?
11420	Fill	11416	0.68	0.22	Secondary Fill. Mid-dark brownish grey silty sand	Worked flint	
11421	Fill	11416	1.34	0.35	Secondary Fill. Mid greyish brown silty sand with light greyish brown mottling	Worked flint	Early prehistoric? (res)
11422	Fill	11416	1.3	0.23	Secondary Fill. Mid greyish brown silty sand	Worked flint	
<b>Trench 115</b>							
General description						Orientation	NE-SW
Trench devoid of archaeology. Consists of ploughsoil and subsoil overlying natural geology of silty sand with occasional gravels						Length (m)	30
						Width (m)	2
						Avg. depth (m)	0.5
Context No.	Type	Fill Of	Width (m)	Depth (m)	Description	Finds	Date
11500	Layer			0.3	Ploughsoil. Mid grey brown silty clay		
11501	Layer			0.2	Subsoil. Mid orange brown silty clay		
11502	Layer				Natural. Mid orange brown silty sand with gravels		
<b>Trench 116</b>							

General description					Orientation	NW-SE	
Trench devoid of archaeology. Consists of ploughsoil and subsoil overlying natural geology of silty sand with occasional gravels.					Length (m)	30	
					Width (m)	2	
					Avg. depth (m)	0.45	
Context No.	Type	Fill Of	Width (m)	Depth (m)	Description	Finds	Date
11600	Layer			0.3	Ploughsoil. Mid grey brown silty clay		
11601	Layer			0.15	Subsoil. Mid orange brown silty clay		
11602	Layer				Natural. Mid orange brown silty sand with rare gravels		

### B.1 Pottery

By Kate Brady

#### Introduction

- B.1.1 Some 3321 sherds of pottery, weighing 28.1kg, were recovered from the evaluation. The assemblage was scanned to identify diagnostic forms and fabrics, provide spot-dates and generally characterise the material. The assemblage was also assessed in terms of its conservation, discard and retention. Fabrics of prehistoric date were given codes based on their principal inclusion types and coarseness. Later Iron Age and Roman pottery fabrics were assigned codes from OA's standard recording system for material of that date (Booth 2016). Forms identified by rim were given codes from OA's system. Reference was also made to the National Roman Fabric Reference Collection (NRFRC; Tomber and Dore 1998), Going's (1987) type series of pottery from Chelmsford and the published assemblage recovered from the kilns at Mucking (Evans *et al* 2016).
- B.1.2 Each context-group was quantified by sherd count and weight (grammes), and any rims present were additionally quantified by estimated vessel equivalent (EVE), which measures the percentage of rim circumference that survives (thus, 0.3 equals 30%). The total was 25.69 EVEs from 219 vessels identified by rim (MV). Pottery data by context are provided in Table 1.
- B.1.3 The following early/middle Iron Age fabrics were noted:
- SG1 Beaker LN-EBA
  - F1 Flint temp LBA-EIA
  - S1 Sandy MIA
- B.1.4 The following late Iron Age and Roman fabrics were noted (NRFRC codes in brackets):
- A35 Campanian 'black sand' amphora (CAM AM 1)
  - B11 Dorset black-burnished ware (DOR BB 1)
  - C10 Shell tempered ware
  - E30 Late Iron Age/early Roman sandy fabrics
  - E40 Late Iron Age/early Roman shelly fabrics
  - E80 Late Iron Age/early Roman grog-tempered ware (SOB GT)
  - E810 Late Iron Age/early Roman grog and sand tempered fabrics
  - F51 Oxford red colour-coated ware (OXF RS)
  - F56 Hadham red-slipped ware (HAD OX)
  - M29 Colchester mortarium fabric (COL WH)
  - O20 Sandy oxidised ware
  - O57 Hadham oxidised ware
  - Q50 North Kent white slipped oxidised fabric

- Q57 Hadham white slipped oxidised ware
- R10 Fine reduced ware
- R20 Sandy reduced ware
- R30 Medium sandy reduced ware
- R40 Miscellaneous reduced fabrics (include micaceous greyware and probable Hadham reduced ware)
- R50 Dark surfaced fabrics
- R90 Coarse-tempered ware
- S30 Central Gaulish samian ware
- S40 East Gaulish samian ware

B.1.5 Additionally, a small amount of post-Roman material was recorded:

- Mill Green ware
- Glazed post-medieval redware

B.1.6 In addition, the following forms identified by rim were recorded:

- BA Small flagon
- BB Large flagon
- C Indeterminate jar
- CB Barrel shaped jar
- CC Narrow-mouthed jar
- CD Medium-mouthed jar
- CE High-shouldered necked jar
- CH Bead-rimmed jar
- CJ Lid-seated jar
- CM Wide-mouthed jar
- D Indeterminate jar/bowl
- E Beaker, indeterminate form
- HB Straight sided bowl
- HC Curving sided bowl
- JB Curving-sided dish (with plain rim)
- K Mortarium

## Description

Context	Sherds	Weight (g)	EVE	MV	Description	Spot-date
305	2	6	0	0	R30	43-410
403	13	82	0	0	body sherds leached out shell E40	LIA-ER
407	3	53	0	0	Glazed Pmed redware base sherd	18-19C
606	1	12	0	0	R30	43-410
1304	1	18	0	0	R20	43-410
1503	23	168	0.74	1	SF 100. JC R10 (shallow and fairly small diameter 10cm), dish with plain rim underscored by groove. (Dating unclear but similar types from mucking e.g form RB.04 are 2-E3C. Burnished. Very slight chamfer at base join. EVE 0.74	120-410
1504	23	811	0.7	1	SF 101 I S30 18/31R with internal roulette. Graffito on base, three crosses (XXX) No stamp (worn) Interior worn from use, rivet repair on wall, footing sherd of a different samian vessel (S40), very worn	120-150
1506	10	338	1	1	SF 102, one vessel. Bulbous, one handled flagon with disc rim North Kent white slipped oxidised ware Q50 fabric, probably mid to late 2C, EVE 100. 4cm rim diameter. (Going form J4)	100-200
1507	1	3	0.03	1	R30 jar/bowl D sample <15>	43-410
1507	1	3	0	0	Sample <12> R20 body sherd	43-410
1508	69	573	0.67	1	Sf 103 One vessel CE R30 high-shouldered jar with very short/no neck with flared everted rim. Decorated with groups of burnished vertical line. EVE 0.67 One very large body and rim sherd and smaller body sherds	125-200
1511	1	366	0.6	1	SF 104 CC R30 (Going form G40) bottle/ narrow necked jar. Globular body very narrow neck two bands of rouletted dec on upper body. Almost complete just small part of rim missing (EVE 0.6) 5cm rim diameter.	100-200
1512	12	77	0.08	1	O20 bead rim D EVE 0.08, R30 O20 R20 body sherds	43-410

Context	Sherds	Weight (g)	EVE	MV	Description	Spot-date
1802	34	232	0.12	1	all-over corded beaker E. Early form. Also body sherd of another beaker with fingernail impressed decoration.	LN-EBA
2800	6	72	0.2	3	R30 2 x bead rim HB bowl straight sided EVEs 0.09, 0.06, CD 0.05	120-410
3304	3	2	0	0	R30 body sherds Sample <2>	43-410
3304	2	4	0	0	glazed body sherds. Mill Green ware	1270-1350
3308	1	9	0	0	R30	43-410
3902	1	2	0	0	R10 roulette dec body sherd	43-410
3904	5	48	0.06	1	R30 body sherds and curving sided dish with plain rim EVE 0.06	120-410
3909	1	11	0	0	R30	43-410
3912	10	130	0	0	E80 fairly fine body sherds	LIA-ER
3918	2	8	0	0	B11 body sherd with acute lattice dec	120-200
3922	6	24	0	0	R30 flakes from kiln waster or spalled vessels Sample <4>	43-410
3923	5	43	0	0	possible pottery kiln wasters	43-410
3926	38	440	0.6	5	C R30 3 x everted rim jars EVEs 0.15, 0.11, 0.12, 0.11, C (with fairly upright rim) R30 (Going form G30) EVE 0.11, D E40 (bead rim, thickened internally). R30 body sherds	43-100
3928	3	51	0.11	1	R20 everted rim handmade jar C EVE 0.11 with fingertip impressed decoration around rim	MIA
4003	108	1157	0.55	8	Almost all R20/R30, S small worn body sherd, CD R30 (Going form G24 1.2) slight hooked rim EVE 0.03, R20 CE EVE 0.06 (Going form G24), C R30 EVE 0.1, H? R40 with flanged moulded rim (poss Hadham reduced ware) EVE 0.03, HB (bead and flange bowl) R30 x2 vessels EVEs 0.07 (incipient flange)0.15 (more prominent bead and dropped flange), body sherd Hadham red slip F56, HB R30 flat rim EVE 0.11	240-410



Context	Sherds	Weight (g)	EVE	MV	Description	Spot-date
4006	341	4026	5.18	19	SF 1 JB R30 straight sided dish fairly shallow, plain rim with groove underneath, slight chamfer at base (Mucking form RB.04.3 c 170-240) EVE 0.05. Body sherds: R90 R30, E40, O57. CD R30 jar with slight bifid rim EVE 0.11, CJ E40 (Going form G5) EVE 0.13, E30 barrel shaped jar/CK several different vessels 3 with stubby everted rims EVE 0.05, 0.27, 0.11, 1 with thickened rim internally EVE 0.07, H (flat rim) M-LIA form EVE 0.05, D E30 flat stubby everted rim EVE 0.03, E R10/fine R30 smooth micaceous black fabric oval bodied beaker with cordons or triangular bead rim like (similar to Going form H22) EVE 0.1, CD R30 (Going form G24) x 4 vessels EVEs 0.1, 0.1, 0.1, 0.15, CD R30 (everted rim) EVE 0.09, CD E30 (flat rim corrugated/ cordons below neck) EVE 0.13, CH R30 flattish bead rim EVE 0.09, E R10 (fine beaker with upright bead rim) EVE 0.11, CE E80 EVE 0.06, CC R30 EVE 0.11, JC R30 (plain rim dish with groove under rim) EVE 0.06, CC R30 EVE 0.11, JC R50/R30 (plain rim dish with slight chamfer base) EVE 0.2, body sherds hadham red (O57) and hadham white slipped red ware also lots of body sherds of above fabrics. Mixed context suggests contamination/ residuality of quite a lot of M-LIA in a L2-E3C context.	150-250 with M-LIA component
4008	62	717	0.3	4	Two different chronological groups of material. M-LIA component with flat thick rimmed jars/bowls in reddish fabric with leached out E40, EVEs D 0.05 (rilling on surf), D stubby everted rim EVE 0.07, D thick squared rim EVE 0.03 also lots of body sherd in this fabric. E (butt beaker) R50 with cordoned body and internally flattened bead rim EVE 0.15, R30 body sherds and prt of flat based jar no rim.	43-70
4011	5	44	0	0	R30	43-410

Context	Sherds	Weight (g)	EVE	MV	Description	Spot-date
4012	1	70	0.15	1	C R30 everted rim EVE 0.15 Q57 body sherd Q oxidised white slipped hadham	200-410
4107	2	16	0	0	E40 leached out shell	LIA-ER
4108	1	3	0	0	E40 small body shed	LIA-Rom
4110	1	30	0	0	E40 leached out shell	LIA-ER
4113	1	7	0	0	R20	43-410
4115	1	8	0	0	body sherd	M-LIA?
4204	9	31	0.05	1	R20 (Going G24) CD EVE 0.05, O20 body sherds, R30 body sherds	43-410
4206	55	725	0.85	6	Mortarium fabric M29 (probable Colchester) with flint grits and sharply hooked rim EVE 0.17, CC R20 with flattened bead rim (Going form G44) EVE 0.21 poss graffito on rim (two scored lines), R10 ED with flat small rim dark surfaced fabric, rim and neck only EVE 0.11, R20 (Going form G24) CE? jar EVE 0.19 small 12cm diameter, D everted rim R30 EVE 0.06, CC R30 (Mucking form GW4) EVE 0.11, body sherds R30, R95, R10 body sherd with scroll dec and cordons. Similar vessels from Mucking kilns (form GC09)	150-250
4207	72	754	0.63	6	R20 HB flat rim EVE 0.1, R30 HB fat square rim EVE 0.04 dark surf, R30 CD (Going G24) EVE 0.14 dark surf, R30 CE with thick flattened bead rim EVE 0.08, R30 CJ (Going G5) EVE 0.2, very worn S30 plain rim with internal groove EVE 0.07 poss drag.15/31 or poss drag.33	150-200
4209	12	177	0.17	1	flint tempered jar C with plain upright rim with flattened top EVE 0.17	LBA-EIA
4211	3	38	0.03	1	R20 C everted rim EVE 0.03, E40? Body sherd	43-410
4215	9	265	0.52	2	HB R30 flat rim bowl small (10cm diameter) EVE 0.2, CJ R20 (globular body, Going form G5) EVE 0.32, finer dark surfaced body sherds, no rim	150-250

Context	Sherds	Weight (g)	EVE	MV	Description	Spot-date
4301	87	629	0.39	7	R20 CE EVE 0.07, O20 body, R30 CE 0.05, CD (Going G24) EVE 0.06, EVE 0.06, EVE 0.1, EVE 0.03, EVE 0.02, R10 possible CC with scored line decoration (body sherds only)	43-410
4303	2	21	0	0	R30 body sherds	43-410
4504	330	2579	1.07	12	Mainly R20 some very sandy with glassy grains CD R20 (Going form G44 3.1) bifid rim EVE 0.1, CD R20 (Going form G24) EVE 0.03, CD R20 (Going form G24) EVEs 0.15, 0.05 CM R10 (Going form E2) CM (EVE 0.06) lid seated ledged/cupped rim (Going form G24) EVE 0.04, H R30 - (Going form E2 3.1) EVE 0.03, R40 body sherds (poss hadham reduced ware) G R10 - EVE 0.11 (poss Going form G19), EF R10 'poppy-head' beaker rim EVE 0.09, E R10 fine beaker rim slightly beaded EVE 0.16. HB (Going form B2/B4?) EVE 0.15, R30 cordoned necked jar/bowl (Going form G19/G20) EVE 0.1.	180-200
4505	91	869	0.6	7	CD x 5 (Going form G24) EVES R30 0.08, R20 0.15, R30 0.09, R20 0.07, R20 0.03, HC F51 (Young form C47) EVE 0.11, C R20 (slightly bifid rim prob 3C) EVE 0.07, body sherds all R20/R30 occ R10	350-410
4506	20	212	0.25	2	Mostly R10 R20 and R30 body sherds, D C10 EVE 0.1 pointed bead rim (Going form B4) bowl poss with chamfered base 15cm diam, D R30 EVE 0.15	140-250
4508	191	1941	1.2	13	Mostly R30 and R20, F51 footing base and stamp decorated body sherd, JC R30 x3 EVES 0.08, 0.09, 0.07, HB R30 3x with incipient flange (230-300) (EVES 0.07, 0.08, 0.05), CM R30 (Going form G7) moulded/ squared rim EVE 0.19, KB M22 (Young form not clear - broken flange (burnt) EVE 0.1. CD R30 (Going form G24) x3 EVES 0.1, 0.07, 0.05 with indented/stabbed decoration on latter. HB R30 x2 (bead and flange bowls) (Going form B6) EVES 0.15, 0.1.	350-410

Context	Sherds	Weight (g)	EVE	MV	Description	Spot-date
4509	25	82	0	0	Sample <22> R30 body sherds	43-410
4509	4	5	0	0	R30 body sherds Sample <22>	43-410
4509	190	1214	1.1	11	All grey wares, R20 some very sandy with large glassy grains brown, reddish brown and grey fabrics, R30 mostly grey, occ R10, occ poss hadham grey/black R40, HB R30 (Bowl with 'incipient flange' (Going form B5) EVE 0.06 and B5.3 (which can continue until end of 4C)EVE 0.07, C several (Going form G24) (EVES - R30: 0.1, 0.1, R20: 0.14, 0.07, 0.05, 0.06; C R30 (Going form G42/43) EVE 0.15 (narrow mouthed insloping bead rim 3-4C), E? R30 beaker or very small jar with cordoned neck EVE 0.15, JC R30 (plain rim dish with groove under rim) EVE 0.15	230-300
4515	75	647	0.49	5	A A35 possible dressel 1 amph (residual), HB R20 2x (straight sided bowls with incipient flange) EVES 0.1, 0.03, R30 narrow necked jar/flask such as G36 (EVE 0.13) , R30 G23 jar EVE 0.2, one with lower flange and bead (EVE 0.03)R30 HB (B4)	230-300
4518	3	42	0.13	2	E810 grog and occ quartz sand. Flat upright rim M-LIA? EVE 0.03, R30 D EVE 0.1	LIA-ER
4605	45	202	0.14	3	R30 3x HB with pointed bead rims. Micaceous dark surfaced greyware all same fabric. EVES 0.06, 0.05, 0.03	140-250
4607	5	117	0	0	body and base sherds from probable narrow necked vessel flagon or bottle BB/CC in R40 micaceous fabric with chattering dec on upper body	43-410
4607	6	19	0	0	R20/R30 body sherds sample <7>	43-410
4611	12	35	0	0	Sample <8> body sherd R30	43-410
4700	104	609	0.65	9	CD x 2 (Going form G42) R30 EVEs 0.07, 0.05, CD (Going form G24) R20 EVEs 0.07, 0.07, 0.06 some with hooked rim, CD (Going form	200-410

Context	Sherds	Weight (g)	EVE	MV	Description	Spot-date
					G24) R30 x3 0.09, 0.13, 0.05, R30 CE EVE 0.06	
4703	21	237	0.28	4	CD R20 (Going form G24) EVE 0.08, D R30 EVE 0.05, JC? R30 (small frag plain rim) EVE 0.05, HB R30 (bead and flange bowl) EVE 0.1	250-410
4705	54	317	0.26	3	R30 JB x2 plain rim EVEs 0.04, 0.04, mostly R30 occ R20 body sherds, C (Going form G24) R30 0.07, R30 D everted rim EVE 0.11	120-410
4706	199	1312	0.94	14	R30 and R20 mostly CD and CC jars (Going form G24) EVEs R30: 0.03, 0.04, 0.06, 0.06, 0.05, 0.10, 0.06, 0.08, 0.03, 0.12, R20: 0.20, 0.03, 0.06, 0.02	100-410
4706	50	447	0.08	2	Sample <25> small body sherds R30, JB plain rim EVE 0.03, R30 CD (Going form G24) EVE 0.05, thin body sherd with pre firing holes, tiny. Function unknown.	120-410
4708	593	3158	3.01	42	Mostly R30 and R20 very small amount of O20 (a couple of sherds). Lots of similar rim forms that are clearly from different vessels. Jars with folded over hooked/ bead rims CD (Going form G24) R20 with glassy grains (Going form G24) EVEs 0.22, 0.10, 0.07, 0.06, 0.11, 0.06, 0.06, 0.06, 0.07, 0.03, 0.12, 0.06, 0.04, 0.03, R20 CE EVE 0.16, R30 CD (Going form G24) EVEs 0.09, 0.08, 0.06, 0.06, 0.03, R30 (Going form G44?) EVE 0.10 (flatish squared rim), CE EVEs 0.11, 0.25 (bottle/flask 7mm diam), R30 CD with neck and thick flat squared rim EVE 0.06 , HB with flattened square almost bifid bead rim EVE 0.05, R30 HC flanged bowl C7 (L1-E2C) EVE 0.03, R30 2x plain rim dish with groove under rim EVEs 0.03, 0.04, R30 HB incipient flange (3C) EVE 0.04, plain rim dishes R30 EVES 0.07, 0.03, 0.05, R30 HB flat bead rim EVE 0.03, R30 plain rim dish x2 EVEs 0.11, 0.12, R30 D x7 EVEs 0.04, 0.05, 0.04, 0.04, 0.05, 0.07, 0.04	200-300

Context	Sherds	Weight (g)	EVE	MV	Description	Spot-date
4710	207	1377	1.52	13	CE R30 Going form G42 jar with flat bead/ recessed rim EVE 0.15, CD R20 (Going form G24) EVEs 0.12, 0.15, 0.10, 0.03, 0.07, 0.09 some rims folded/ hooked over. CE R30 (Going form G36) EVE 0.07, CD R30 (Going form G24) EVEs 0.07, 0.1, 0.09, D R30 D EVE 0.09, H R30 EVE 0.04 (bowl with flattened bead rim)	200-410
4713	21	188	0.24	3	E R10 (everted rim of prob beaker) EVE 0.07, JC R30 EVE 0.1, HB R30 (bead and flange bowl) EVE 0.07	250-410
5006	3	3	0	0	Sample <21> R30 body sherds	43-410
5714	18	103	0.03	1	Mostly body sherds, R30 and R20, one plain rim JC R30 EVE 0.03	120-410
7806	1	48	0	0	flint tempered body sherd	LBA
9808	1	17	0	0	R20 body sherds	43-410
11104	1	2			Flint tempered body sherd	LBA-EIA
11419	3	19	0	0	sample <1> flint tempered body sherds	LBA-EIA
<b>Total</b>	<b>3321</b>	<b>28103</b>	<b>25.72</b>	<b>220</b>		

Key: EVE estimated vessel equivalent; MV minimum number of vessels; LN/EBA late Neolithic/early Bronze Age; E/M/LIA early/mid/late Iron Age

Table 1: Summary and quantification of the pottery by context

### Prehistoric

- B.1.7 The earliest pottery recovered from the site dated to the late Neolithic to early Bronze Age period and accounted for 1% of the total assemblage by sherd count. Sherds from a single all-over corded beaker were recovered from a pit in Trench 18, alongside a single body sherd from another beaker vessel with impressed fingernail decoration.
- B.1.8 A small amount of flint-tempered late Bronze Age to early Iron Age material was recovered from Trenches 42, 78 and 114 and constitutes 0.5% of the total assemblage by sherd count. One rim was present in the small group, from a jar/bowl with an upright rim, flattened on the top.
- B.1.9 Three sherds from a vessel of probable middle Iron Age date were recovered from a feature in Trench 39 and these make up 0.09% of the total assemblage by sherd count. The vessel was in a smooth sand-tempered fabric with an upright flattened rim with fingertip impressions around the top.

### Late Iron Age to early Roman

- B.1.10 Some 0.9% per cent of pottery by sherd count was recovered from context-groups dated to the late Iron Age or early Roman period. The pottery was recovered from

trenches 4, 39, 41 and 45; none of the amounts were large, with the biggest group coming from trench 39, weighing 130g. The context-groups contained no pottery that must date after c AD 43 and it remains possible that deposition was confined to the late Iron Age. However, as fabrics of late Iron Age tradition continued in use in the region for some decades after the Roman conquest, a pre-Roman date is not certain. A small range of fabrics were noted, with leached out shell-tempered wares taking the largest share. No rims were present, so it was not possible to identify vessel types.

### Early Roman

B.1.11 A total of 3% of the assemblage by sherd count (100 sherds) belonged to context-groups dated to the early Roman period (c AD 43-100). This material was recovered from two context groups (from trenches 39 and 40) and included pottery of late Iron Age tradition (particularly E40) in combination with pottery of certain post-conquest date, all sand-tempered reduced wares in fabric R30 and R50. The vessels in fabric E40 included one jar/bowl from Trench 39 with an internally thickened bead rim and three vessels in the same fabric from Trench 40 with thick, flat rims of M-LIA form. One had a stubby everted rim, and one a thick, squared rim. One vessel had a rilled surface. In Trench 39, the E-ware vessels were accompanied by three everted rim jars in fabric R30. In Trench 40, the M-LIA type vessels were accompanied by a butt beaker in fabric R30 that dates to no later than AD 70/80, and a jar with an internally flattened bead with a cordoned body in dark surfaced fabric R50.

### Middle Roman

B.1.12 A total of 30.1% of the assemblage by sherd count belonged to contexts groups dated to the middle Roman period (c AD 120-250).

B.1.13 Five complete or near-complete vessels were collected from a single cremation burial in Trench 15. Vessel SF 104 was substantially complete, with just a small part of the rim missing. Together, the pottery dates to the 2nd century AD.

B.1.14 Vessel SF 100 (Context 1503) is a flat-based shallow and fairly small dish in fine reduced ware (R10) with a plain rim underscored by a groove. The surface of the vessel is burnished and there is a very slight chamfer at the base. Similar vessels from Mucking were dated to the 2nd to early 3rd century. Context 1504 contained vessel SF 101, a Central Gaulish samian ware (S30) Drag. 18/31R dish with internal roulette decoration. The interior was worn from use and there was a rivet repair on the vessel wall. Three crosses had been scratched after firing into the exterior surface of the base, within the footring. This vessel dates to c AD 120-150. Another samian ware sherd from this context was in East Gaulish fabric S40. Vessel SF 102 (Context 1506) is a bulbous, single handled small flagon with a disc rim in North Kent white-slipped oxidised ware (with worn-off slip). This vessel is probably mid to late 2nd century in date. The third vessel accompanying the burial is SF 103 (Context 1508), a high shouldered jar in fabric R30 with a very short neck and everted rim and it is decorated with burnished vertical lines. Vessel SF 104 (Context 1511) is a bottle/narrow-necked jar with a globular body and two bands of roulette decoration on the shoulder. Similar vessels from Mucking date to the 2nd century.

B.1.15 The second focus of activity in the middle Roman period was in the area of Trenches 42, 45 and 47. Much of the material was collected from features associated with several pottery kilns: rake-out pits and layers and surrounding enclosures (the kilns themselves were left *in situ*). The pottery was overwhelmingly in reduced ware fabrics R20 and R30 and included a large amount of distinctive very sandy material with large

quartz grains along with dark surfaced moderate sandy ware, some of which was very micaceous. There were a large number of vessels represented by rim from these trenches, some of which could only broadly be dated to the middle to late Roman period, but some forms were more closely datable with reference to the Chelmsford and Mucking typologies. In general, the material from this area dated from the mid-2nd to 3rd century but some forms were more closely dated to the earlier part of this range and some were later, suggesting that the kilns were functioning throughout this period.

- B.1.16 Contexts dated to the mid-2nd to early-3rd century (4206, 4207, 4504, 4506, 4605) contained a range of vessels (see Table 1), including straight-sided dishes with pointed rims in a dark micaceous moderately sandy fabric and at least six medium-mouthed jars, one with slightly bifid rim, in very sandy fabric R20. A narrow-mouthed jar in fabric R20 had a flattened bead rim, with a possible graffito on the rim, comprising two scored lines. Another jar with the same form was in fabric R30. One body sherd in dark surface fabric R10 was from a vessel with cordons and burnished scroll decoration around the shoulder. Similar forms from the Mucking kilns were dated to AD 120-250. There was also lid-seated, ledged/cupped rim of a globular bowl/jar and a lid seated jar in fabric R30 and at least three beakers in finer fabric R10, one of which was probably a poppy-head beaker, while another was a bag-shaped vessel with a small bead rim. Straight-sided bowls in fabrics R20 and R30 had flat rims and bead rims and there was also a necked jar/bowl with a cordoned body, also in fabric R30. A single mortarium rim was recovered, probably from Colchester (fabric M29). It is in a white/buff fabric with flint trituration grits and has a sharply hooked rim.
- B.1.17 Two large groups recovered from Trench 40 (4006 and 4008) dated from the mid-2nd to mid-3rd century may represent deposition of settlement waste rather than material associated with the kilns. The fabrics formed two distinct chronological groups which indicate contamination, probably due to intercutting with features of mid to late Iron Age date. This earlier assemblage comprises vessels in fabrics E30 and E40, such as lid-seated jars, bead rim jars/bowls and jars with stubby everted rims. The remainder of the material in this context was Roman, and included forms dating from the late 2nd to mid-3rd century. This material was mainly in fabric R30, and there was none of the very sandy fabric R20 associated with the kiln area. Vessel forms recorded included two plain rim dishes, one of which had a wide groove under the rim (a late 2nd to mid-3rd-century form), and one which had a slightly chamfered base. There were four medium mouthed jars in fabric R30 and two jars or beakers in finer fabric R10, one of which was oval bodied with cordons. This context also included a small number of body sherds from the Much Hadham industry in Hertfordshire (O57).
- B.1.18 Two contexts in Trench 45 (4509 and 4515) date more closely to the mid to late 3rd century. Vessels were all in fabrics R20 and R30 and vessel forms included two narrow-mouthed jars (one with an in-sloping bead rim), six medium-mouthed jars and three bowls with an 'incipient flange' (Going 1987, type B5), a form that dates from the early part of the 3rd century which eventually develops into the form with a more prominent bead and flange, of which there was one example in this context.
- B.1.19 Two body sherds of black-burnished ware with burnished lattice decoration (acute angle) were recovered from Trench 39 and date to AD 120-200.

### **Late Roman**

- B.1.20 A total of 42% of the assemblage by sherd count belonged to contexts groups dated to the late Roman period (c AD 200/230-410).



- B.1.21 As with a large portion of the middle Roman assemblage, the later Roman assemblage was largely recovered from trenches in the northern part of the site. The largest concentrations of material of from contexts of clearer late Roman date were recovered from Trenches 40, 45 and 47. Although much of the material could only be broadly dated to the late Roman period, the identification of some forms allowed closer dating of some contexts to the earlier or later part of this period.
- B.1.22 As a whole, the group was characterised by the continued deposition of large amounts of material in the area of the kilns. The same fabrics were present, overwhelmingly very sandy fabric R20 and more moderately sandy R30 fabrics some of which were also dark surfaced and/or micaceous, as they were in the earlier period.
- B.1.23 The main form dating these contexts is the straight-sided bead-and-flanged bowl (Going 1987, type B6), which is a later Roman form, developing from the 'incipient flange' form, which were also present in these contexts alongside the later form. Otherwise, the forms were generally similar to those of the mid-Roman period, with medium-mouthed jars, narrow-necked jars/flasks and the plain rim dish with a groove under the rim recorded. There is a slight increase in material from the Hadham kilns, with red slipped sherds, a white slipped sherd and some grey/black reduced ware. A small amount of Oxford colour-coated wares also assisted in dating contexts to this period, and as Going (1987) suggests that this fabric appears in the area in the mid-4th century, this enabled contexts 4505 and 4508 to be more closely dated to the latter half of the 4th century.
- B.1.24 More material was recorded from context groups in the kiln area that could only be broadly dated to the middle to late Roman period. This material was similar in character overall with the same R20 and R30 fabrics and a variety of forms, but with none that were sufficiently chronologically diagnostic to assign these contexts more closely to a period. Particular mention can be made of the assemblage from Trench 47, which contained large deposits of pottery totalling 1107 sherds and represents further deposits of material associated with the kilns.

### **Post-Roman**

- B.1.25 Two sherds of medieval pottery were recovered from context 3304 in Trench 33. These are body sherds of Mill Green ware and date to AD 1270-1350.
- B.1.26 A single sherd dated to the post-medieval period and was recovered from context 407 in Trench 4. It is a base sherd of Glazed Post-medieval Red ware and dates to the 18th-19th century.

### **Discussion**

- B.1.27 Overall, the assemblage was in fragmentary condition. The mean sherd weight (weight divided by sherd count) is 8.46g, which is characteristic of an assemblage of relatively small fragments. This figure is consistent across the periods and site areas. The pottery recovered from the area of kiln activity had a mean sherd weight of 8.4g, consistent with the number for the site as a whole and suggests that this material too may have been redeposited prior to eventual deposition. It should be noted that the vessels from the cremation burial in Trench 18 were substantially or nearly complete. The pattern is retained when we look at rim fragmentation. The mean rim percentage (EVE divided by number of vessels (MV) for the assemblage overall is 0.12 EVE or 12%. The pottery from the area of the kilns is similar, with a value of 10.3% suggesting

that there is no difference in fragmentation between this material and that recovered elsewhere on the site.

- B.1.28 While a proportion of the assemblage is likely to have been fired in the kilns on the site, no wasters or products certain to have come from the kiln were identified. However, the large concentrations of material in the trenches where the kilns were found, and those immediately surrounding them, suggest that the kilns were producing a range of greywares, mostly very sandy grey/brown fabrics, some with glassy quartz grains, along with dark more moderately sandy fabrics and lighter coloured moderately sandy greywares. A large amount of the fabric was notably micaceous. The forms are consistent with those manufactured in the region and most vessels were paralleled at Mucking (Evans *et al* 2016) and/or Chelmsford (Going 1987).
- B.1.29 The fairly small range of fabrics recovered, with little from other regional industries and few imports, further suggests that the assemblage was dominated by wares made on the site or locally, with the very micaceous fabrics likely to be derived from the local siliclastic sediments of the Thanet formation which surrounds the area of the site (BGS 2020).
- B.1.30 Assessment of status is problematic, as it is unclear if the pottery associated with the kiln areas was used in a nearby settlement or represents production waste from material that was intended to leave the site. However, the lack of clear wasters and the inclusion of a small amount of material from other sources, most notably from the Hadham industry, the small amount of samian ware and the later material from the Oxford industry, suggests that at least some material derived from a nearby settlement. This includes finer table wares and mortaria and a single sherd of an amphora.
- B.1.31 The cremation burial, accompanied by five vessels of 2nd-century date may be part of a larger cemetery and appears to pre-date the phase of pottery production. Pottery recovered from kiln 4503 and 4704 dates production to the 2nd century or later; pottery from the stokehole of 4503 dates from AD 180. Oxford red colour-coated ware of 4th-century date was collected from the firing chamber, but this is generally not consistent with the dating of the remaining pottery from kiln, and suggests that the kiln continued to receive material long after its final firing.

## B.2 Ceramic building material

By Cynthia Poole

### Introduction

- B.2.1 A small quantity of ceramic building material (CBM) amounting to 17 fragments weighing 1968g was recovered from trenches 6, 40, 45, 46, 57 and 80 (Table 2). The assemblage consists of fairly small fragments, all less than 110mm in size, generally in fresh or lightly abraded condition with a slightly below average mean fragment weight of 116g. The assemblage contains material of Roman, medieval and post-date. The assemblage has been spot dated and is summarised in the table below.
- B.2.2 The assemblage has been fully recorded on an Excel spreadsheet in accordance with guidelines set out by the Archaeological Ceramic Building Materials Group (ACBMG 2007). The record includes quantification, and details of fabric type, form, surface finish, forms of flanges, cutaways and vents, markings and evidence of use/reuse (mortar, burning etc). The terminology for Roman tile follows Brodribb (1987); coding for markings, tegula flanges, etc. follows that established by OA for the recording of CBM and tegula cutaway types are linked to those classified by Warry (2006). Fabrics were characterised on the basis of macroscopic features supplemented by the use of x20 hand lens for finer constituents.

### Roman tile

- B.2.3 Roman tile accounted for 13 fragments (1477g) and included examples of the most common forms: tegula and imbrex roof tiles and brick. These were made in a variety of red-orange fine sandy fabrics similar to those found at other sites in the area such as Stanford Wharf (Shaffrey 2012) and Mucking.
- B.2.4 Tegulae were the most common form and occurred in ditches in trenches 40, 45 and 57. They were neatly finished with smooth upper surface, knife trimmed edges and, in some cases, the rougher lower surfaces had been knife-trimmed. They measured 20-24mm thick and in nearly all cases had been burnt grey or heat discoloured on one or more surfaces. Flanges survived in three cases and exhibited a variety of common profiles ranging in size from 16-32mm wide and 40-54mm high. One also had a lower cutaway of type C5, dated by Warry to AD 160-260. Two fragments of imbrex were recovered from trenches 40 and 57. Both had a rougher finish than the tegulae and were gently curved possibly indicative of an angular profile. They measure 10 and 17-19mm thick and one had been burnt.
- B.2.5 Two pieces measuring 31-36mm thick are both probably brick. One was a corner fragment and certainly formed a brick, probably a pedalis or lydion, as it is relatively thin for brick and unlikely to be one of the larger forms. Neither piece was burnt.

### Post-Roman CBM

- B.2.6 Medieval - post-medieval flat roof tile was found in trenches 6, 46 and 80. Two thicker and more crudely made fragments measuring 14mm thick are probably medieval in date, whilst a thinner example 12mm thick with a neater finish is likely to be post-medieval in date, c 17th-19th century. A single poorly preserved broken brick measuring c 61mm thick, also from Trench 80, is probably of 17th-18th century date.

Context	Ditch	Spot Date	Nos	Wt (g)	Forms	Comments
606	604	Med	1	87	Roof: flat	
4003	4005	RB	4	511	Flat tile/tegula	
4006	4005	AD 160-260	1	406	Tegula	Curved flange (type E) 32mm W x 54mm H; lower cutaway type C5, 68mm L.
4006	4005	RB	1	114	Imbrex	
4006	4005	RB	1	100	Flat tile/tegula	
4006	4005	RB	2	27	Brick?	
4508	4507	RB	1	72	Tegula	Rounded flange with finger groove along exterior top edge (type F2), 21mm W x 40mm H
4515	4514	RB	1	111	Brick RB	
4615	4614	Med	1	22	Roof: flat	
5707	5707	RB	1	112	Tegula	Rectangular flange (type A) 16mm W x 46mm H
5714	5707	RB	1	24	Imbrex	
8005	8003	C17-C18?	1	366	Brick?	
8005	8003	C17-C19	1	16	Roof: flat	

Table 2: Summary of CBM forms and dating

## Conclusions

B.2.7 The assemblage is small and is useful in providing additional dating evidence for some features. The Roman tile is focused on three trenches, 40, 45, and 57, suggesting activity or settlement in the area. However, the tile is not indicative of any form of masonry structure in the vicinity of the evaluation. The assemblage is typical of that found on lower status rural settlements where material has been obtained from higher status settlements for reuse. The mechanism for this is unclear, whether casual scavenging of useful materials or a direct relationship with an establishment with a villa that allowed the reuse of disused materials. The emphasis on flat tile forms such as tegula and brick is typical, as these could be more easily reused in the construction of minor structures such as hearths, ovens and kilns. The evidence of burning on more than half the pieces is strongly suggestive that much or all the tile was obtained for such reuse and could perhaps relate to the kilns found in the evaluation.

## B.3 Fired clay

By Cynthia Poole

### Introduction

B.3.1 A modest quantity of fired clay (FC) amounting to 248 fragments weighing 3437g was recovered, the majority found in trenches 40-42 and 45-7, whilst small amounts were found in trenches 4, 18, 78 and 111 (Table 3). The assemblage has a mean fragment weight of 13g, which is slightly above average, and abrasion is moderate, possibly a reflection of the fairly soft character of the fabrics, rather than other factors. In general, fired clay cannot be closely spot dated except for a small number of diagnostic forms, usually portable oven and hearth furniture. However, certain characteristics or combinations of forms are more typical of some periods than others, but for the most part fired clay is reliant on associated dateable artefacts for its phasing. The majority of the fired clay has been phased to late Iron Age-Roman, with the main emphasis on middle-late Roman, and the general character of the assemblage is consistent with this. A small quantity may be prehistoric. The assemblage has been recorded on an Excel spreadsheet in accordance with guidelines set out by the Archaeological Ceramic Building Materials Group (ACBMG 2007), which, whilst not intended specifically for fired clay, provide appropriate guidance. Fabrics were characterised on the basis of macroscopic features supplemented by the use of x20 hand lens for finer constituents.

### Prehistoric

- B.3.2 Fired clay phased as prehistoric was recovered from two ditch fills, 1802 and 7806. Deposit 1802 was phased as Late Neolithic-early Bronze Age on the evidence of a placed deposit of pottery. This context produced 20 fragments of fired clay (458g), made in a fine sandy clay fabric containing moderate medium quartz sand fired to red, orange brown and grey-black. Heavy wear or abrasion means that only the larger fragments retain any evidence of form and original moulded surfaces. One piece may be the flat circular end and vertical edge of a large cylindrical pedestal, c 110-120mm in diameter by over 43mm high. A second piece appears to form the flat end of a circular sectioned rod or bar, 36-39mm in diameter, whilst a third piece could be the square corner of a rectangular plate 43mm thick.
- B.3.3 Ditch fill 7806 is dated to the late Bronze Age on the basis of the pottery and produced a single fragment of fired clay object (128g). This piece also appears to form the smooth flat moulded end surface of a cylindrical pedestal, starting to curve into a vertical. Piercing the end surface is a perforation 21mm in diameter. The perforation has either been placed off-centre or the pedestal is in fact oval rather than circular, ranging between 140 and 160mm in diameter and measuring over 37mm high. It is made in a red mottled, yellowish brown fine sandy clay matrix containing moderate-frequent medium and coarse quartz sand and small flint grits 2-3mm.
- B.3.4 The fired clay from both these features is unusual for both periods and would fit more comfortably with the Roman assemblage described below. Such material would be unusual in a Neolithic or Bronze Age context and other factors should be considered in the dating of the features such as residuality or later soil accumulation in the tops of early features to explain the anomaly in the finds evidence.

## Roman

- B.3.5 The bulk of the fired clay was found in features of late Iron Age - Roman date, the majority occurring in middle-late Roman contexts. These included two kilns, 4503 and 4704, in Trenches 45 and 47 and an oven, 4619 in Trench 46, which may be the source of much of the fired clay in these trenches.
- B.3.6 The fired clay fabrics all utilised a fine sandy clay matrix, which contained variable densities from sparse to frequent of medium and coarse round quartz sand and in some examples small angular flint grits 1-3mm or very rarely small red iron oxide inclusions. These differences probably all reflect the natural variability of locally available clay suitable for structures. Deliberately added filler occurred in the form of organic voids from the addition of chaff or crushed straw. The organic tempered clay had been used more frequently for kiln furniture but was also used for structural material.
- B.3.7 Structural material (141 fragments, 1159g) tended to be made in the coarser varieties of the sandy fabric and was mainly oxidised fired to red, orange or brown, though some reduced grey/black pieces were also present. Structural material retains few diagnostic features and most of the material designated as structural has a single moulded surface forming the interior wall surface or lining. These ranged in thickness from 15 to 63mm thick, representing thinner lining or repairs to the surface and the thicker solid wall structure.
- B.3.8 In addition to the basic walling, a number of fragments may derive from dome plates used to close the top of the kiln. These formed fairly thin slabs measuring 9-18mm thick with dense straw or chaff impressions entirely coating one surface, whilst the opposite side had been moulded to a fairly flat even surface with evidence of finger marks. One piece had a narrow, rounded edge, suggesting these were prefabricated as individual items, though whether the organic impressions result from the surface on which the plates were made or from organic material placed over the unfired kiln load is uncertain. The dome plate was all associated with kiln 4503.
- B.3.9 A piece of luting from layer 4612 is irregular in form but shows evidence of a rectangular object, probably a firebar, being attached to a structure and the lump of luting moulded around it leaving finger marks over the surface and shaped to ensure a gap through the suspended floor of the kiln.
- B.3.10 A fragment from 4505 has been identified potentially as part of a pedestal. It has one flat and one curved surface, conjoined, which appear to form part of a large pedestal, possibly oval or rectangular with rounded end. A second pedestal fragment has been identified from 4006. The fragment has a smooth flat surface curving to a convex curving edge, apparently part of a cylindrical pedestal c 100mm diameter. Although pedestals may be portable, it is more likely that these formed an integral element of the kiln structure as seen in the kilns recorded at Mucking (Jones 1973, 15 & fig 2).
- B.3.11 Portable kiln furniture in the form of firebars and plates was identified from trenches 40, 45 and 47. In most cases insufficient survived to make firm identifications but the designations are based on characteristics of surface finish and organic impressions. The firebars mostly had a single surface surviving, except for one piece with a side edge, but the linear form of the objects was suggested by the long parallel straw/grass impressions running lengthways through the objects. The size of the firebars could not be determined, but the largest fragment would indicate a bar over 88mm wide. This is larger than the examples recorded at Mucking (*ibid.*, 18) and may indicate these are

rectangular pedestal fragments rather than firebars. The kiln plates took the form of rectangular slabs with flat or gently domed moulded surfaces, straight edges and square corners measuring between 16 and 37mm thick. These may have formed the suspended floor within the kiln or have had other uses such as cheek pieces protecting the walls of the flue or firing chamber. Smaller examples may have been used as setters within the kiln.

### Undated

B.3.12 A small quantity of unphased material included residual kiln fragments in the modern ploughsoil, indeterminate fragments in ditch 11103, though one of these may be a burnt coprolite and amorphous fragments from cremation 4512, which represent fragments of burnt clay scraped up off the pyre surface.

### Conclusions

B.3.13 The fired clay is dominated by kiln debris, which can be related to *in situ* kiln structures in the three main areas producing fired clay. The character of the material suggests that the form of the kiln structures may be similar to others found in Essex at Mucking (Jones 1973) and Orsett 'Cock' (Carter 1998). The range of structural material and kiln furniture is indicative of kilns with a suspended floor separating the lower furnace section from the upper chamber containing the load for firing. Dating evidence suggests that these structures are of middle – late Roman date. The number of kilns exposed in the evaluation suggest that these could form part of a larger group representing a significant pottery industry at this period and could make an important contribution to the understanding and development of the industry in this area.

B.3.14 The fired clay found in features assigned a prehistoric date is not compatible with the dating of the features and would be very unusual in such a context. It is probable that the fired clay is of later date, relating to the Roman kilns and that the features needs to be re-examined either in relation to their dating or the possibility of later intrusive activity.

Context	Sample	Nos	Wt (g)	Class	Form	Impressions
1802	~	20	458	Structural?	Oven/kiln?	None
4003	~	1	19	Indeterminate		None
4006	~	5	164	Furniture?	Indeterminate	None
4006	~	3	42	Structural?	Indeterminate	Wattle
4006	~	14	122	Kiln Furniture	Kiln plate?	straw/organic
4006	~	1	26	Kiln Furniture	Pedestal?	None
4008	~	6	51	Kiln Furniture?	Kiln bar?	Straw/grass
4012	~	10	62	Structural?	Oven/kiln?	None
4108	~	2	21	Indeterminate		None
4113	~	2	4	Indeterminate		None
4207	~	7	39	Indeterminate		Occasional organic
4504	~	1	11	Kiln Furniture	Kiln plate?	Chaff
4504	~	4	257	Kiln Furniture	Kiln plate & dome plate	Straw stems
4504	~	2	25	Structural?	Kiln/oven wall/lining	None
4505	~	3	311	Kiln Furniture	Pedestal?	Straw stems
4505	~	8	274	Kiln Furniture	Kiln bar?	Straw stems
4505	~	3	126	Kiln Furniture	Kiln bar?	Straw stems
4506	~	5	59	Structural?	Kiln/oven wall/lining	None
4508	~	1	14	Structural?	Dome plate?	Straw stems

Context	Sample	Nos	Wt (g)	Class	Form	Impressions
4509	~	1	4	Structural?	Dome plate?	Straw/grass stems
4509	~	3	8	Structural?	Kiln/oven wall/lining	None
4509	<22>	21	62	Structural?	Kiln/oven wall/lining	Fine organic; 1 wattle?
4512	<23>	25	16	Structural?	Pyre base	None
4604	~	10	62	Structural?	Kiln/oven wall	None
4610	~	1	49	Structural?	Kiln/oven wall?	coarse chaff
4611	~	2	35	Structural?	Kiln/oven wall?	None
4611	<8>	22	31	Structural?	Kiln/oven wall?	None
4613	~	4	133	Structural	Kiln luting	None
4615	~	17	239	Structural?	Kiln/oven wall	Chaff frequent
4616	~	1	89	Structural?	Kiln/oven?	Chaff frequent fine chaff impressions 1-8mm, occasional up to 18mm L.
4617	~	2	152	Structural?	Kiln/oven wall	None
4700	~	1	7	Structural?	Kiln/oven?	None
4705	~	9	118	Kiln Furniture	Kiln plate?	Chaff
4706	~	7	20	Furniture?	Indeterminate	Chaff
4706	<25>	7	18	Furniture?	Indeterminate	Chaff
4708	~	8	64	Structural?	Kiln/oven wall?	Chaff/crushed straw
4708	~	6	94	Kiln Furniture	Kiln bar?	None
4713	~	1	11	Furniture?	Indeterminate	None
7806	~	1	128	Furniture	Pedestal?	None
11104	~	1	3	Indeterminate	Indeterminate	amorphous

Table 3: Summary of fired clay by context



## B.4 Flint

By Michael Donnelly

### Introduction and methodology

- B.4.1 Evaluation brought to light a moderate flint assemblage of 70 pieces of struck flint and 215 burnt unworked fragments weighing 821g (Table 4).
- B.4.2 The artefacts were catalogued according to OA South's standard system of broad artefact/debitage type (Anderson-Whymark 2015; Bradley 1999), general condition noted and dating was attempted where possible. The assemblage was catalogued directly onto an Open Office spreadsheet. During the assessment additional information on condition (rolled, abraded, fresh and degree of cortication), and state of the artefact (burnt, broken, or visibly utilised) was also recorded. Retouched pieces were classified according to standard morphological descriptions (e.g. Bamford 1985, 72-77; Healy 1988, 48-9; Bradley 1999). Technological attribute analysis was initially undertaken and included the recording of butt and termination type (Inizan *et al.* 1999), flake type (Harding 1990), hammer mode (Onhuma and Bergman 1982), and the presence of platform edge abrasion.

### Results

- B.4.3 The assemblage was very clearly flake based with a low blade index of just 6.38% and included a number of flake cores and tools indicative of late Neolithic and Bronze Age flint working. The tool forms included a wide range of forms with scrapers (3), denticulates (2), a microdenticulate, a piercer, a retouched flake and an end truncation. The last two tools were probably early prehistoric in date, while two well-made scrapers were very probably later Neolithic or early Bronze Age in date. The density of flintwork recovered was low and many originated as residual finds in later feature. However, several features contained decent assemblages of between five and 14 pieces with the latter originating from five separate fills in later prehistoric ditch 11416 and could very probably represent a contemporary assemblage.

Category type	Total
Flake	44
Blade	3
Blade index	6.38% (3/47)
Irregular waste	8
Sieved chip 10-2mm	1
Core rejuvenation flake	1
Crested blade	1
Core multiplatform flakes	1
Core fragment flakes	3
Scraper end	1
Scraper side and end	1
Scraper disc	1

Category type	Total
Piercer	1
Denticulate	2
Microdenticulate	1
End truncation	1
Retouched flake	1
Total	98
Burnt un-worked	215/821g
No. burnt (%)	8.57% 6/70
No. broken (%) (not including waste)	32.86% 23/70
No. retouched (%) (not including waste)	12.86% 9/70

Table 4: The flint assemblage

Category type	Total	Percentage
Ditches	50	71.43
Topsoil	8	11.43
Cremations	5	7.14
Indeterminate fills	5	7.14
Pits	2	2.86
Total	70	[100]

Table 5: The flint assemblage by context type

- B.4.4 The flints were recovered from a restricted range of contexts (34), with 25 containing just one flint while seven contexts contained five or more (Table 5). These included two groups of five and six from fills of late Bronze Age-early Iron Age ditch 11416, which had a total of 14 pieces, as well as seven and five flints from ditch fills 11104 and 11106 that lacked other dating material.
- B.4.5 Burnt unworked material was recovered from 20 contexts but most contained only sparse amounts. Burnt layer 3922 contained the largest assemblage of 87 pieces weighing 306g, all of which came from a sample, and it reasonable to assume that this deposit probably contained a far more substantial assemblage. Ditch fill 11419 from ditch 11416 was the only other context to contain more than 100g of this material with 131g all from samples.

### Raw material and condition

- B.4.6 Cortex was present on 48 of 70 pieces (68.57%) and included numerous different types, including a solitary example of Bullhead Beds material (Dewey and Bromehead

1915). Chalk cortex was most common (22, 45.83% (four of which were heavily weathered)), followed by a thin abraded/weathered cortex typical of North Downs flint (16/48, 33.33%). Small quantities of thermal surfaces (3/48, 6.25%), rolled (2/48, 4.17%) and indeterminate (4/48, 8.33%) completed the list.

- B.4.7 Most of the flint was in fresh (36/63, 57.14%) or lightly edge-damaged condition (19/63, 30.16%) but seven pieces displayed moderate (11.11%) levels of edge damage and one was heavily rolled (1.59%). Cortication was largely light (54/63, 85.71%) with limited amounts of no or moderate cortication (6.35% each) and only one heavily corticated piece (1.59%). Overall, the condition of the material suggests an assemblage that includes lightly disturbed pieces alongside some *in situ* material.

## Discussion

- B.4.8 Later prehistoric material made up the bulk of the finds recovered, including the largest assemblages found in ditches. Ditch fill 4006, cut 4005 and ditch fills 4508-9, cut 4507 yielded five and seven flints respectively. Ditch 4005 contained three flakes, a piece of irregular waste and an end scraper that is likely to pre-date the middle Iron Age fill. The remaining flake debitage was largely undiagnostic but two of the flakes had soft hammer bulbs and are unlikely to be later prehistoric in date. Late Roman ditch 4507 contained four flakes, a piece of irregular waste and a core fragment geared towards flake production and are likely to be residual later prehistoric material. Two of these pieces refitted indicating that this material had not moved far.
- B.4.9 Trench 111 contained two ditches that are currently undated. Ditch 11103, fill 11404 contained seven flints while ditch 11105, fill 11406 had five. Both assemblages were flake-dominated but 11403 also contained a blade and an early tool form, an end truncation and included one or two thin regular flakes or earlier character. Ditch fill 11406 had four flakes and a flake-core fragment. There is some indication that these assemblages could be early in date, Neolithic or perhaps even Mesolithic. As such, it would probably imply that they are residual. If that were the case, it would indicate that some form of flint-rich deposit was present here in prehistory and the possibility that fragments of it could remain preserved in localised areas should be considered.
- B.4.10 Ditch 11416 in trench 114 contained 14 flints from five contexts (6, 5, 1, 1 and 1 flint). The assemblage contained nine flakes, one blade, a piece of irregular waste, a multi-platform flake core, a core fragment (both geared towards flake production) and microdenticulate on a second core fragment. The flakes tended to be hard-hammer struck and could easily be a contemporary assemblage with the ditch. The single tool is likely to be residual as these pieces are uncommon after the Neolithic period. Similarly, the blade, which shows signs of utilisation is also likely to be residual.
- B.4.11 Undated cremation 4511 contained five pieces from the cremation deposit (4512) and one from the fill (4513). These comprised two flakes, two irregular waste fragments and a sieved chip and are likely to be residual finds.
- B.4.12 Very limited early forms including three blades and a probable microdenticulate on a core fragment from ditch 11416 that also yielded one of the blades. In addition to this, some of the remaining tools could also be early such as the piercer from topsoil 5000.
- B.4.13 Two quite fine scrapers were present in the assemblage and comprised a near disc scraper from topsoil 5900 and an end scraper from mid Iron Age ditch fill 4006. Both these tools are likely to date to the later part of the Neolithic or early Bronze Age.

Additionally, a core rejuvenation flake from pit fill 4306 is also likely to be early but as it was the only flint from that feature it is also very probably residual.

B.4.14 Overall, this evaluation indicates moderate lithic potential with the possibility that further work could identify flint-rich deposits. The presence of Neolithic or earlier tool forms could suggest that flint-rich features such as pits may be encountered during any further works. Similarly, the flint-rich ditch fills could amount to a considerable and potentially regionally important assemblage should further works result in the more comprehensive excavation of this archaeological landscape.

## B.5 Glass

By Ian R Scott

- B.5.1 There are just three pieces of vessel glass from the evaluation (Table 6).
- B.5.2 From context 5006 there is a small, thin sherd of olive-green glass, which lacks any diagnostic features. It may be from the pushed-up base of a vessel and is probably post-medieval and later in date.
- B.5.3 There is the base of a moulded cylindrical bottle in very pale green glass from context 7404. The bottle was moulded probably in a three-piece mould and dates to the later 19th or early 20th century.
- B.5.4 From context 7905 there is a large sherd from a broad cylindrical wine or beer bottle of mid-18th century date. The body of the bottle was formed in a dip mould.

Context	No.	Description
Context 5006	(1)	Small sherd, quite thin, possibly from a low push-up of a vessel base. Olive green glass. Not closely datable. Not measured. Sample < 21 >. Probably post-medieval or later
Context 7404	(2)	Cylindrical bottle base. From moulded cylindrical bottle with low push-up and small mamelon. Possibly moulded in three-piece mould. Very pale green glass. D: 80mm.  Late 19th-century or early 20th-century.
Context 7905	(3)	Bottle. Lower body/heel from broad cylindrical bottle with basal sag. Probably made in a dip mould. Green glass, iridescent weathering. D: 120mm.  Probably mid-18th-century wine or beer bottle.

Table 6: Summary of glass finds

## B.6 Metal finds

By Ian R Scott

B.6.1 There are ten metal finds, comprising seven iron objects and 3 copper alloy objects (Table 7).

B.6.2 The iron objects include three probable nails (contexts 1210, 4207 and 4504), now encrusted with corrosion, a single hobnail (context 4607), and an irregular fragment of thick plate (context 1210). There is also a possible blade fragment (context 4615) and a length of bar or strip with an apparent irregular expansion, partly obscured by corrosion products (context 7905). None of the iron objects can be dated, with the exception of the possible Roman hobnail.

B.6.3 The three copper alloy finds comprise a simple bow brooch with spring of 1st-century date (context 4504), Roman copper alloy coin that could be of 1st or 2nd century date (context 4206). The brooch type dates to between the 1st century AD with some pre-Conquest examples (Bayley and Butcher 2004, 147).

Context	No.	Description
Context 1210	(1)	Nail. Two refitting fragments, encrusted with corrosion, possibly complete. Fe. L: 74mm. Sf 105
	(2)	Plate. Irregular oval fragment of thick plate, Fe. L: 80mm; W: 57mm; Th: 12mm. Sf 106
Context 4206	(3)	Roman cu alloy issue. Obverse: Worn bust facing R. Legend (incomplete): . . ANV . . . ; Reverse, Minerva? with spear flanked by 'SC'. Legend (incomplete) . . .AV[G]VST . . D: 27mm x 25mm. Sf 6
Context 4207	(4)	Nail stem or bar fragment. Fe. L: 36mm.
Context 4504	(5)	Bow brooch. Simple bow brooch with four coil spring and internal chord. Flat tapered bow, plain. Catchplate incomplete. L extant: 40mm. Cu alloy. 1st-century AD. Sf 2
	(6)	Nail with small flat head, possibly complete but encrusted with corrosion. Fe. L: 37mm.
Context 4508	(7)	Strip fragments. 3 x fragments of cu alloy strip, possibly refit, one piece folded back on itself. L: c 30mm; W: 3.3mm. Sf 4
Context 4607	(8)	Hobnail. Fe. Not measured. Roman. Sample < 7 >
Context 4615	(9)	Blade fragment? Possible knife blade fragment with single cutting edge. Fe. L: 65mm; W: 22mm. Sf 3
Context 7905	(10)	Strip or bar (W: 10mm) with irregular expansion (40mm x 44mm). Purpose uncertain. Fe. L: 76mm; W: 44mm.

Table 7: Summary of metal finds

## B.7 Clay pipe

By John Cotter

### Introduction and methodology

- B.7.1 A single piece of clay pipe weighing 12g was recovered. Given the small amount this has not been separately catalogued but is fully described below.
- B.7.2 For the London area, pipe bowls are assigned form codes based on Atkinson and Oswald's (1969) London pipes typology with bowl types assigned to an abbreviated code (eg AO22).

### Description

- B.7.3 Context 8004. Spot-date: c 1840-1910. Description: 1 piece (weight 12g). A complete pipe bowl of AO30 form in fresh condition and with around 26mm of stem still attached. This is a 'briar copy' pipe - in that it loosely copies the form of wooden briar pipes in having a rounded base without a spur. Briar pipes became popular from the mid-19th century onwards. In this case the rim of the pipe is not horizontal – like briar pipes – but droops forward at quite a steep angle like pipes of AO29 form (c 1840-1880). This also falls into the 'fancy' pipe category in having fairly elaborate moulded decoration typical of the Victorian period. The over-all design is clearly phytomorphic and appears to be a variation of the fairly common acorn design, with the lower third of the bowl decorated to resemble an acorn cup and the upper bowl representing the acorn proper. The cup is decorated with high-relief vertical ribbing, which springs from the neck of the stem. On the underside of the bowl and stem is a large moulded oak-leaf. The front and back seams of the bowl, above the cup, are decorated with a vertical spray of small delicate oak-leaves; these are very faint and probably the result of a worn-out mould. Otherwise the upper two-thirds of the bowl is plain and slightly bulbous, resembling an acorn. There may have been an impressed maker's mark further down on the sides of the stem, but no trace of this survives. This is an attractive and decorative pipe but otherwise not particularly uncommon.

## B.8 Stone

By Ruth Shaffrey

### Introduction

- B.8.1 A total of nine pieces of stone were retained and submitted for analysis (Table 8). These were examined with a x10 magnification hand lens for signs of use. Worked or utilised items were recorded and details entered into a Microsoft Excel spreadsheet. The stone includes three fragments of unworked stone (4700, 4708, 5714). In addition, there is a single unworked spherical flint nodule (4006). These are naturally formed, but it may represent a manuport.
- B.8.2 Five fragments from four rotary querns were recovered. Two tiny fragments of Mayen lava were found in context 4515 (5g). Fragments from two separate Millstone Grit querns were found in contexts 4605 and 4012 (387 and 235g respectively). A larger fragment of Greensand quern was found in context 4006 (568g).
- B.8.3 The lava quern has been imported from the continent (most lava querns are believed to come from Mayen in Germany but there is some evidence for the use of French lava). The Millstone Grit querns represent two different sources, that from 4708 being much more highly feldspathic and coarser, but both are likely to have come from Derbyshire/Yorkshire. The Greensand quern is very similar to rocks found in the Blackdown Hills of Devon, but a more local source seems more likely although it has not been possible to investigate sources at this stage.
- B.8.4 The querns are very likely to be Roman in date, although lava and Millstone Grit querns were also used during the Saxon and medieval periods and millstones of these lithologies continued in use into the modern period.
- B.8.5 All the unworked stone can be discarded as can the lava fragments, as these are too small to be suitable for geochemical or petrographic analysis. The quern fragments and sphere should be retained.

Context	Function	Notes	Size	Lithology
4605	Rotary quern	Small fragment of disc type quern or millstone. Worn thin with flat parallel faces but no centre or circumference. One face is worked and the other has traces of straight grooving. Could be harped but not enough survives to be sure	32mm thick	Millstone Grit
4012	Rotary quern	Small fragment of disc type quern or millstone. Worn thin with flat parallel faces but no centre. Small section of the circumference survives and this is barely curved suggesting possibly part of millstone although it is smoothed and its shape could have been altered through reuse. Both faces are worked/smoothed	33mm thick	Millstone Grit



<b>Context</b>	<b>Function</b>	<b>Notes</b>	<b>Size</b>	<b>Lithology</b>
4006	Rotary quern	Fragment of probable rotary quern as evidenced by the pecked and smoothed face. The other face is flat and roughly tooled suggesting possibly a lower stone. It is of flat disc form but neither the centre nor the circumference survive. It is burnt and blackened across one broken edge	46mm thick	Greensand
4515	Rotary quern	Tiny degraded fragment		Lava
4006	Sphere	Nodule, almost perfectly spherical and smooth. Unworked manuport?	39mm	Flint

Table 8: Details of worked stone

## **B.9 Slag and Coal**

By Geraldine Crann

- B.9.1 Context 4616 contained a single small piece of non-magnetic slag, 120g.
- B.9.2 Context 4706 contained one small fragment of coal, 2g.
- B.9.3 Context 8005 contained two small fragments of coal, 6g.

### C.1 Human Remains

By Mark Gibson

#### Introduction and provenance

- C.1.1 Two deposits containing burnt human bone (1507 and 4512) were recovered.
- C.1.2 Deposit 1507 was contained within urn 1508 (SF 103) and had been buried in pit 1509 (Trench 15) with several ceramic vessels deposited as grave-goods. The pottery indicates a 2nd-century date for the burial. The urn had suffered some horizontal truncation, although this was limited as some of the rim was present.
- C.1.3 Burnt bone deposit 4512 was unurned and was found within pit 4511 in Trench 45. The pit was 0.35m wide and 0.06m in depth. The burnt bone was within a mid-brownish grey sandy silt matrix. It was thought at the time of excavation that 4512 represented a cremation burial, but osteological analysis could not confirm whether bone was human or non-human animal.

#### Methodology

- C.1.4 Urned deposit 1507 was block lifted and excavated under laboratory conditions in 12 spits of 20mm, before being processed and analysed. Deposit 4512 was recovered in bulk in accordance with recommended practice (McKinley 2004, 9).
- C.1.5 The deposits were processed by wet sieving which sorted them into fractions of >10mm, 10-4mm, 4-2mm and 2-0.5mm. The bone from the >10mm, 10-4mm and 4-2mm fractions was separated from the extraneous material (e.g. stones). The smallest fraction sizes (2-0.5mm) were not sorted but were rapidly scanned for identifiable skeletal remains and artefacts. Estimations of the proportions of bone present within the 2-0.5mm fractions were made visually and recorded in the archive.
- C.1.6 All bone was analysed to record colour, weight and maximum fragment size. Total bone weights have not included bone from the 2-0.5mm fraction.
- C.1.7 Each fraction was examined for identifiable bone elements and the presence of pyre and/or grave goods. The minimum number of individuals (MNI) present was estimated based on the identification of repeated elements and/or the presence of juvenile and adult bones in the same deposit. Where possible, estimation of age and sex was attempted following published methods (Buikstra and Ubelaker 1994).

#### Results

- C.1.8 A summary of total bone weight, colour, age and sex estimation, for each deposit, is given in Table 9. Fragmentation and skeletal elements represented in deposit 1507 are given in tables 2 and 3, respectively.

#### Bone weights

- C.1.9 The total bone weight of 1507 and 4512 was 818.3g and 0.2g, respectively (Table 9). Investigations in modern crematoria have found that the bone weight of cremated adult individuals ranges from between 1,000 to 2,400g, with an average of 1,650g (McKinley 2000, 269). Archaeologically recovered cremation deposits have an expected weight

range of 600-900g (McKinley 2013, 154). Deposit 1507 falls comfortably within the expected archaeological range, but just below the modern range. Deposit 4512 falls well below both ranges.

### **Fragmentation**

- C.1.10 The majority of bone from deposit 1507 (75.4%; 616.7g) was from the >10mm fraction, indicating a very low level of fragmentation. The majority of bone was consistently from the >10mm fraction in each spit, with amounts ranging from 65.3-92.3% (Table 10). Percentage of bone from the 4-2mm fraction in each spit ranged from 2.2% to 8.2% and was 4.5% (37.3g) for all spits combined. Deposit 4512 was moderately fragmented with bone only being present in the 10-4mm fraction.
- C.1.11 Long bones generally comprised the largest fragments of bone observed in all but one of the spits from deposit 1507. The largest fragment was a piece of tibial shaft which measured 69mm. This is unsurprising given the general thickness of the cortex in long bones, especially those of the lower limb, which means they are more likely to survive than other, more fragile bones. The largest fragment from 4512 was a piece of unidentified bone measuring 14mm.

### **Skeletal representation**

- C.1.12 Bones from deposit 1507 were identified to skeletal region and element, where possible (Table 3). Deposit 4512 lacked features which would allow it to be positively identified as human or non-human animal. This is not surprising, considering the very small size and quantity of the bone present.
- C.1.13 Lower limb was the most frequently identified skeletal region in deposit 1507 and comprised 21.1% of the total weight of the bones (Table 11). Both upper limb and skull regions were also well represented (14.5% and 14.4% of the total bone weight, respectively). Three fragments of tooth were identified, all of them from roots, in addition to a fragment of left mandibular body, which included the second and third molar sockets (but no teeth).
- C.1.14 Axial elements were poorly represented and comprised 3.2% of the total bone weight. They were identified in eight of the 12 spits (spits 4 and 6-12).

### **Colour of the cremated bone**

- C.1.15 When cremated, the organic content of bone is altered by a process called oxidation, the degree of which is reflected in the colour of the bone, which may range from brown/orange (unburnt), to black (charred: c 300°C), through hues of blue and grey (incompletely oxidised, up to c 600°C) to white (fully oxidised, >600°C) (McKinley 2004, 11). Thus, bone colour may be used as an indication of the efficiency of the cremation, in terms of the quantity of fuel used to build the pyre, the temperature attained in various parts of the pyre, and the length of time over which the cremation was undertaken (ibid, 11).
- C.1.16 The colour of most of the burnt bone from the present site was white, accounting for between 70% (1507) and 80% (4512) of the total bone weights. This indicates that the corpses would have been placed on their pyres in such a way as to maintain a consistent high temperature and oxygen supply (McKinley 2013, 158), enabling a temperature in excess of 600°C to be reached. A high proportion of fully oxidised bone is a common observation in archaeological cremation burials (McKinley 2006, 84).

C.1.17 The remaining burnt bone was blue/grey or black in colour, indicating exposure to lower temperatures. This may have been due a number of reasons. For example, the cremation process may have been inhibited in places of thicker overlying soft tissue; until these are removed, the bone is insulated from oxygen and the heat of the fire, resulting in variation in the degree of bone oxidation across the skeleton (McKinley 1989, 65; McKinley 2013, 158). In deposit 1507, it was noted that fragments of left and right proximal ulna, left proximal radius and unsided radial shaft were predominantly black in colour, whilst bones with a thicker covering of flesh, such as the femora, were more consistently white in colour. This would seem to indicate that the arms were positioned in such a way that the elbow areas were away from the most intense heat of the pyre.

### **Demography**

C.1.18 Only deposit 1507 had elements which could be positively identified as human. It had no repeated elements, nor landmarks indicating conflicting age or sex estimations. These observations suggest the deposit comprises a minimum of one individual. The individual was adult, based on the presence of a fragment of mandible with tooth sockets for the second and third permanent molars. Sex was estimated as possible male, based on fragments of the occipital bone, including a relatively prominent nuchal crest.

### **Pathology and non-metric traits**

C.1.19 No pathology or non-metric traits were observed.

### **Pyre/grave goods**

C.1.20 No pyre or grave goods were observed within the burnt bone deposits. No staining or residue, indicative of pyre/grave goods, were observed.

### **Discussion**

C.1.21 The assemblage comprises one urned (1507) cremation and one unurned (4512) burnt bone deposit. The latter could not be positively identified as human or non-human animal. Deposit 1507 comprised at least one individual, identified as a possible male adult. Overall, bones were well burnt, or predominantly white (fully oxidised), indicating pyre temperatures of >600°C (McKinley 2004, 11). No pathology was observed.

C.1.22 The total weight (818.3g) of deposit 1507, which is well within the expected range (600-900g) for archaeologically recovered cremation burials (McKinley 2013, 154), coupled with the fact that it was contained within an urn, is consistent with this context representing a formal cremation burial. Although the urn had been horizontally truncated, it is unlikely that this has resulted in the loss of bone from the urn: the urn still had fragments of rim surviving and no burnt bone was recovered from the first spit (the uppermost layer in the urn). At 818.3g the weight of 1507 exceeds the 584g mean weight observed for urned cremations from nearby Cemetery II at Mucking (Lucy *et al* 2016, 345), but is below the 1069g weight of untruncated urned cremation burial 6725, discovered on the Pepperhill to Cobham road scheme, site D (Gibson *et al.* 2012, 454).

C.1.23 Unlike elements from elsewhere on the skeleton, the bones of both forearms of 1507 were predominately black, suggesting less efficient cremation of this part of the corpse. Given that femoral fragments were mostly pure white it is unlikely that the flesh on the forearms was insulating these bones against the heat. A more likely explanation is that the corpse had been positioned with the elbows positioned away from the most intense

heat. Further, identified fragments of humeral and metacarpal bones were consistently white, indicating exposure to the full heat of the pyre. This suggests that the corpse had been placed on the pyre with the arms slightly abducted from the body, elbows flexed and the hands lying on the pelvis or torso.

C.1.24 Considering the very low weight of 4512 (0.2g) and the fact that the bone would not be positively identified as human, it is unlikely to be an intentional cremation burial. It probably it represents some coincidental burnt animal remains within a burnt deposit.

<b>Deposit</b>	<b>Samples</b>	<b>Total weight (g)</b>	<b>Colour</b>	<b>Age</b>	<b>Sex</b>	<b>Non-metrics/ pathology/ burnt and unburnt animal bone</b>
1507	9-20	818.3	White: 70% Grey/blue: 15% Black: 15%	Adult	??M	MNI = 1
4512	23	0.2	White: 80% Grey/blue: 20%	U	U	Unable to confirm whether these fragments are human or non-human

Key: ??M = possible male. U = Unknown. Note: total bone weights do not include material from the unsorted 2-0.5mm residues

Table 9: Burnt Bone - Osteological Summary

<b>Deposit</b>	<b>Spit</b>	<b>Total weight (g)</b>	<b>&gt;10mm (g)</b>	<b>10-4mm (g)</b>	<b>4-2mm (g)</b>	<b>Max. frag. size</b>
<b>1507</b>	1	0	-	-	-	-
	2	1.3	1.2 (92.3%)	-	0.1 (7.7%)	24mm: unid. long bone
	3	17.6	12.8 (72.7%)	3.5 (19.9%)	1.3 (7.4%)	47mm: humeral shaft
	4	17.9	13.7 (76.5%)	3.8 (21.2%)	0.4 (2.2%)	51mm: humeral shaft
	5	52.1	44.5 (85.4%)	6.4 (12.3%)	1.2 (2.3%)	68mm: humeral shaft
	6	34.0	22.2 (65.3%)	10.1 (29.7%)	1.7 (5%)	40mm: femoral shaft
	7	71.4	58.6 (82.1%)	10.7 (15%)	2.1 (2.9%)	69mm: tibial shaft
	8	116.9	83.3	27.7	5.9	64mm: tibial shaft

<b>Deposit</b>	<b>Spit</b>	<b>Total weight (g)</b>	<b>&gt;10mm (g)</b>	<b>10-4mm (g)</b>	<b>4-2mm (g)</b>	<b>Max. frag. size</b>
			(71.3%)	(23.7%)	(5%)	
	9	141.2	104.8 (74.2%)	31.4 (22.2%)	5.0 (3.6%)	59mm: humeral shaft
	10	160.4	123.9 (77.2%)	31.2 (19.5%)	5.3 (3.3%)	60mm: femoral shaft
	11	125.1	91.8 (73.4%)	25.6 (20.5%)	7.7 (6.1%)	66mm: fibula shaft
	12	80.4	59.9 (74.5%)	13.9 (17.3%)	6.6 (8.2%)	42.7mm: cranial vault
<b>Total</b>	-	<b>818.3</b>	<b>616.7 (75.4%)</b>	<b>164.3 (20.1%)</b>	<b>37.3 (4.5%)</b>	<b>69mm: tibial shaft</b>
<b>4512</b>	-	0.2	-	0.2 (100%)	-	14mm: unid

Table 10: Summary of Fragmentation (deposit 1507)

<b>Skeletal Element</b>							
<b>Spit</b>	<b>Skull</b>	<b>Axial</b>	<b>Upper Limb</b>	<b>Lower Limb</b>	<b>Unid. Long Bone</b>	<b>Unid. Other</b>	<b>TOTAL</b>
2	-	-	-	-	1.2g (92.3%)	0.1g (7.7%)	<b>1.3g</b>
3	-	-	Humeral shaft 7.9g (44.9%)	-	4.3g (24.4%)	5.4g (30.7%)	<b>17.6g</b>
4	-	Ilium 0.3g (1.7%)	Humeral shaft 7g (39.1%)	Tibial shaft 3.8g (21.2%)	4.1g (22.9%)	2.7g (15.1%)	<b>17.9g</b>
5	-	-	Humeral shaft 18.8g (36.1%)	Tibial shaft 8.7g (16.7%)	14.3g (27.5%)	10.3g (19.7%)	<b>52.1g</b>
6	Cranial vault 0.6g (1.8%)	LV arch 1.9g (5.6%)	Clavicle shaft 1.5g (4.4%)	Ilium, femoral shaft 10.6g (31.2%)	8.7g (25.5%)	10.7g (31.5%)	<b>34.0g</b>

<b>Skeletal Element</b>							
<b>Spit</b>	<b>Skull</b>	<b>Axial</b>	<b>Upper Limb</b>	<b>Lower Limb</b>	<b>Unid. Long Bone</b>	<b>Unid. Other</b>	<b>TOTAL</b>
2	-	-	-	-	1.2g (92.3%)	0.1g (7.7%)	<b>1.3g</b>
7	L mandibular body, cranial vault 17g (23.8%)	Vertebral body fragment 1.9g (2.7%)	Humeral head fragment, humeral shaft, unla/radius shaft 6.9g (9.7%)	Navicular body fragment, tibial shaft, fibula shaft, ilium 15.1g (21.1%)	13.5g (18.9%)	17g (23.8%)	<b>71.4g</b>
8	Cranial vault, occipital bone, mandible, molar root 13.1g (11.2%)	Rib shaft 5.0g (4.3%)	R proximal ulna, humeral shaft 20.7g (17.7%)	Tibial shaft, MT1 head, fibula shaft, acetabulum fragments 20.7g (17.7%)	25.4g (21.7%)	32g (27.4%)	<b>116.9g</b>
9	Occipital bone, cranial vault, molar root 23.4g (16.6%)	Rib shaft 0.7g (0.5%)	Humeral head frag, humeral shaft, radial shaft, MC shaft (?2-5) 20.2g (14.3%)	Femoral shaft, fibula shaft, navicular fragments, MT shaft (?2-5) 22.5g (15.9%)	30.2g (21.4%)	44.2g (31.3%)	<b>141.2g</b>
10	Occipital bone, mandibular body, cranial vault, tooth root 29.1g (18.1%)	Spinous process, LV arch, vertebral arch, rib, superior facet of CV2 6.7g (4.2%)	Radius shaft, L clavicular shaft, distal humerus, humeral shaft, ulna shaft 16.3g (10.2%)	Proximal tibia, MT shaft, femoral shaft, tibial shaft 43.2g (26.9%)	24.2g (15.1%)	40.9g (25.5%)	<b>160.4g</b>
11	Cranial vault, parietal bone,	LV arch, vertebral articular facet,	L proximal radius 10.4g (8.3%)	Femoral shaft, femoral condyle,	18.4g (14.7%)	42.1g (33.7%)	<b>125.1g</b>



<b>Skeletal Element</b>							
<b>Spit</b>	<b>Skull</b>	<b>Axial</b>	<b>Upper Limb</b>	<b>Lower Limb</b>	<b>Unid. Long Bone</b>	<b>Unid. Other</b>	<b>TOTAL</b>
2	-	-	-	-	1.2g (92.3%)	0.1g (7.7%)	<b>1.3g</b>
	occipital bone 24.7g (19.7%)	transverse process, rib 7.1g (5.7%)		proximal tibia, fibula shaft 22.4g (17.9%)			
12	Cranial vault 10.1g (12.6%)	LV arch 2.6g (3.2%)	L proximal ulna 8.8g (10.9%)	Talar body, tibial shaft, ilium 25.5g (31.7%)	5.7g (7.1%)	27.7g (34.5%)	<b>80.4g</b>
<b>Total</b>	<b>118g (14.4%)</b>	<b>26.2g (3.2%)</b>	<b>118.5g (14.5%)</b>	<b>172.5g (21.1%)</b>	<b>150g (18.3%)</b>	<b>233.1g (28.5%)</b>	<b>818.3g (100%)</b>

Key: R= right, L= left, MC = metacarpal, MT= metatarsal, CV= cervical vertebrae, LV= lumbar vertebrae

Table 11: Cremation 1507 - summary of identified elements and bone weights per spit

## C.2 Environmental Samples

By Richard Palmer

### Introduction

- C.2.1 Two deposits containing burnt human bone (1507 and 4512) were recovered.
- C.2.2 Twenty-five samples were taken from the evaluation, primarily for the retrieval and assessment of charred plant remains (CPR) and the recovery of bones and artefacts.

### Method

- C.2.3 The samples were processed in their entirety at Oxford Archaeology using a modified Siraf-type water flotation machine. The flots were collected in a 250µm mesh and heavy residues in a 500µm mesh and dried. The residue fractions were sorted by eye and with the aid of a magnet while the flot material was sorted using a low power (x10) binocular microscope to extract cereal grains and chaff, smaller seeds and other quantifiable remains.

### Results

- C.2.4 A summary of the samples and flot assessment is presented in Table 12. The samples come from a range of features across the site though twelve are from cremation spits and these produced minimal quantities of material. Due to the presence of intact grain and heavily fragmented grain in some samples fragmented grain has not been quantified in Table 12.
- C.2.5 **Trench 4.** Sample 5 is from fill 403 of ditch 402 dated as Late Iron Age to Early Roman. The flot produced predominantly charcoal in good condition. Grain fragments are present but have not been quantified in Table 12. Weed species include goosefoots (*Chenopodium* sp.) and sedges (*Carex* sp.). A few fragments of fired clay and burnt stone were recovered from the heavy residue.
- C.2.6 **Trench 11.** Sample 6 is from fill 1105 of posthole 1104 and is undated. Due to a large flot volume only 150ml was assessed at this stage. Recovered material was all charcoal in very good condition with the presence of ring porous fragments likely. With 100+ both of >10mm and >4mm in size there is major scope for further analysis with the potential for investigating whether the material is indicative of the post being burnt *in situ* or reuse of the feature. Radiocarbon dating would also be possible.
- C.2.7 **Trench 15.** Samples 9 to 20 are from spits of cremation 1509 dated as mid-2nd century AD. Minimal flot volumes were produced and no identifiable charred material was produced beyond rare charcoal fragments. Cremated bone was recovered from the heavy residues and is considered separately.
- C.2.8 **Trench 33.** Sample 2 is from fill 3304 of pit 3303 and is medieval in date. Recovered charcoal is in good condition with limited vitrification on some fragments, though some have one or more planes <2mm in size. Grain is in mixed condition with wheat (*Triticum* sp.) being present though some identifications are uncertain due to damage. Additional fragments of grain are also present but not quantified. Goosefoots (*Chenopodium* sp.) and rachis fragments were also identified. Pottery, bone and burnt stone were recovered from the residue.
- C.2.9 **Trench 39.** Sample 3 is from fill 3917 in cut 3915 which is Middle Roman in date and is probable *in situ* burning from an oven/hearth. Recovered charcoal was in good to

excellent condition though some fragments have planes <2mm in size and these may not be identifiable. Further identification work would be recommended with possible bark and diffuse porous fragments observed. Burnt flint and stone were recovered from the residue.

- C.2.10 Sample 4 is from layer 3922 which is the final firing layer in Roman oven 3920. A large quantity of charcoal in good condition was recovered with potential for further identification work. A single wheat grain (*Triticum* sp.) was identified along with a variety of weed species including goosefoots (*Chenopodium* sp.), sedges (*Carex* sp.) and speedwells (*Veronica* sp.). Burnt flint and stone along with a few fragments of pottery were recovered from the heavy residue.
- C.2.11 **Trench 45.** Sample 22 is from fill 4509 of ditch 4507 which is Late Roman in date. Charcoal is in good condition with roundwood present. Small grain fragments were present but have not been quantified in Table 12. A good quantity of pottery and fired clay were recovered from the residue.
- C.2.12 Sample 23 is from fill 4512 of possible cremation 4511 and is undated. A good quantity of charcoal was recovered with more than 25 fragments being >4mm in size. Other identified material included dock (*Rumex* sp.) and sedges (*Carex* sp.) along with several small legumes, likely to be vetches. Fired clay and a small amount of cremated bone was recovered from the residue.
- C.2.13 Sample 24 is material from around cut 4511. A few fragments of charcoal were the only significant charred material recovered. The residue produced little in the way of material.
- C.2.14 **Trench 46.** Sample 7 is from fill 4607 of cut 4606 and is dated as Roman. Recovered charcoal is in good condition. Fragments of grain are present in the flot but are not quantified in Table 12. Pottery, burnt flint and stone and some iron was recovered from the residue.
- C.2.15 Sample 8 is from fill 4611 of pit 4608 which is undated. Recovered charcoal is in good condition. Most recovered grain was heavily damaged making the distinction between wheat (*Triticum* sp.) and barley (*Hordeum* sp.) difficult as some of the damaged fragments had barley-like features. One definite wheat grain was identified. The weed assemblage was dominated by dock (*Rumex* sp.). Burnt flint, fired clay and pottery were recovered from the residue.
- C.2.16 **Trench 47.** Sample 25 is from fill 4706 of cut 4712 which is Middle to Late Roman in date. This flot produced a diverse CPR assemblage and has charcoal in good condition. Grain was in generally poor condition with most examples being difficult to identify. The majority of the grain is likely to be wheat (cf *Triticum* sp.) and this can be further taken to be spelt (cf *Tritium spelta*) based on the recovered glumes being spelt-like in character. A single barley grain (*Hordeum* sp.) was identified with a second potentially also present. Oat (*Arvensis* sp.) is also represented but floret bases are missing, so no determination as to wild or domestic oat is possible. Small legumes, likely to be vetches, and a single fragment of hazelnut (*Corylus avellana*) were also identified. The weed assemblage consists of species common to disturbed or open ground such as dock (*Rumex* sp.), goosefoots (*Chenopodium* sp.) and ribwort plantain (*Plantago lanceolata*). A large quantity of pottery was recovered from the residue.

C.2.17 **Trench 50.** Sample 21 is from fill 5006 of ditch 5005 which is undated. All recovered material was less than 4mm in size and was limited to charcoal and some goosefoots (*Chenopodium* sp.). The residue produced a small quantity of flint and some pottery.

C.2.18 **Trench 114.** Sample 1 is from fill 11419 of ditch 11416 which is dated as Late Bronze Age/Early Iron Age. A small quantity of material was recovered with charcoal in good condition. Identified grain was in fair condition with wheat (*Triticum* sp.) present and further grain fragments present but not quantified in Table 12. A few weed seeds were present, primarily dock (*Rumex* sp.) and goosefoot (*Chenopodium* sp.). Burnt flint and stone along with pottery was recovered from the residue.

### **Discussion**

C.2.19 The samples indicate that the features contain charred remains that are generally in good condition, so the area can be considered to have good potential for the recovery of this material. Identification of charred material indicates diverse assemblages are present on site. Localised examples of poor preservation are more indicative of the pre-depositional histories of the material than taphonomic processes following deposition.

#### *Late Bronze Age/Early Iron Age*

C.2.20 One sample is present from this phase and produced material of only limited interpretive value.

#### *Late Iron Age/Early Roman*

C.2.21 The sample from this phase produced fragmented grain which limits interpretive value.

#### *Roman*

C.2.22 Multiple samples were taken from features of this phase. Samples 3 and 4 are both associated with ovens and offer potential for further identification work with the charcoal to explore fuel usage. Samples 9 to 20 which are from cremation spits produced little in the way of charred material.

C.2.23 Sample 25 produced a diverse assemblage with both wheat and barley being identified and the possibility of oat also being grown domestically though this could not be verified. Several weed species common to disturbed or cultivated ground were present and are considered to be crop contaminants.

#### *Medieval*

C.2.24 A single sample was taken from a feature dated to this period and offers limited potential insight into cultivation during this period with grain and rachis fragments present in the assemblage.

#### *Undated*

C.2.25 Several samples were taken from features with no spot-dating available. Sample 6 was from a posthole that contained a large quantity of charcoal. Species identification could rule out the interpretation of the material being from the burning of the post and the flint also offers an opportunity to date the feature by AMS radiocarbon. Sample 8 also offers material that could be used to date the feature. Sample 23 from the cremation in trench 45 also offers the potential to date this feature.

Sample no.	Context no.	Trench	Feature/Deposit	Date	Sample vol. (L)	Flot vol. (ml)	Charcoal >2mm	Grain	Chaff	Weeds	Molluscs	Other	Notes
1	11419	114	11416	LBA/EIA	40	25	++	++		++			10YR 5/6 silt loam. Frequent modern roots.
2	3304	33	3303	Med	5	18	+++	++	+	++		+	10YR 3/3 silt loam. Few modern roots.
3	3917	39	3915	MR	5	26	+++			+			10YR 3/2 silt loam. Few modern roots.
4	3922	39	3922	RB	15	75	++++	+		++		+	10YR 3/3 and 10YR 2/1 silt loam. Frequent modern roots.
5	403	4	402	LIA-ER	20	12	+++		+	+			10YR 5/6 silty clay loam. Few Modern roots.
6	1105	11	1104		30	1000	++++						10YR 3/3 and 10YR 5/8 sandy silt loam.
7	4607	46	4606	RB	10	22	+++			+			10YR 4/3 silt loam. Few modern roots.
8	4611	46	4608		20	46	++	+		++		+	10YR 2/2 silty clay. Mostly modern roots.
9	1507	15	1509	MR	0.25	1							10YR 4/4 sandy silt loam.
10	1507	15	1509	MR	1	2	+						10YR 4/4 sandy silt loam.
11	1507	15	1509	MR	0.75	3	+						10YR 4/4 sandy silt loam.
12	1507	15	1509	MR	0.75	2	+						10YR 4/4 sandy silt loam.
13	1507	15	1509	MR	0.75	2				+			10YR 4/4 sandy silt loam.
14	1507	15	1509	MR	0.75	3							10YR 4/4 sandy silt loam.
15	1507	15	1509	MR	0.75	2							10YR 4/4 sandy silt loam.

Sample no.	Context no.	Trench	Feature/Deposit	Date	Sample vol. (L)	Flot vol. (ml)	Charcoal >2mm	Grain	Chaff	Weeds	Molluscs	Other	Notes
16	1507	15	1509	MR	2	2							10YR 4/4 sandy silt loam.
17	1507	15	1509	MR	0.75	1							10YR 4/4 sandy silt loam.
18	1507	15	1509	MR	0.75	1							10YR 4/4 sandy silt loam.
19	1507	15	1509	MR	0.75	2					+		10YR 4/4 sandy silt loam.
20	1507	15	1509	MR	2	2	+						10YR 4/4 sandy silt loam.
21	5006	50	5005		40	200	++			+			10YR 4/6 sandy silt loam. Mostly modern roots.
22	4509	45	4507	LR	40	10	++		++	+			10YR 4/4 silty clay loam. Frequent modern roots.
23	4512	45	4511		10	60	++++			++			10YR 4/3 silty clay loam. Some modern roots.
24	4513	45			15	16	+						10YR 4/4 silt loam. Frequent modern roots.
25	4706	47	4712	MR/LR	40	100	++++	++	+++	++		++	10YR 3/3 silt loam.

Key: +=present (up to 5 items), ++=frequent (5-25), +++=common (25-100), ++++=abundant (100+).

Table 12: Assessment of charred plant remains flots

## C.3 Animal Bone

By Lee G Broderick

### Introduction

- C.3.1 A total of 167 animal bone specimens were recovered from the site (Table 13), most of which were collected by hand. Environmental samples were also taken and were sieved at 10mm, 4mm, 2mm and 0.5mm fractions but did not produce any identifiable specimens. Features on the site were dated on the basis of associated ceramic finds (seriation), mostly to the Roman period.
- C.3.2 All material from dated contexts was recorded in full, with the aid of the Oxford Archaeology skeletal reference collection and standard identification guides, using a diagnostic zone system (Serjeantson 1996). Material from undated contexts and material recovered from environmental samples that could not be identified, was not recorded.

### Description

- C.3.3 Preservation on the site was poor (Figure 47), likely to be due to acid soils. No doubt this affected the size of the recovered assemblage and also the proportion which could be identified. What could be identified consisted entirely of domestic mammals and mostly came from ditches excavated in the north of the site.
- C.3.4 Domestic cattle (*Bos taurus taurus*) is the most common species on the site, present in every phase (Table 13). Also present is pig (*Sus domesticus*), caprine (sheep [*Ovis aries*] and/or goat [*Capra hircus*]) and horse (*Equus caballus*). The only ageing data comes from the large mammals: fused distal epiphyses of a horse metacarpal and tibia are of limited potential, suggesting that the animal(s) survived into adulthood. Similarly, six domestic cattle longbones had fused epiphyses but a mandible with a tooth row was also recovered from late Iron Age/early Roman context 3912. This indicates an age at death of between 34 and 43 months. A domestic cattle radius from early Roman context 4008 has an oblique chop through the medial side of the proximal end, consistent with a more industrialised or rapid approach to primary butchery.

### Conclusions

- C.3.5 Little can be read into such a small assemblage. Domestic cattle and sheep are the mainstay of the rural economy in Iron Age and Roman Britain, with pig and horse also common, and so this site fits that pattern.

	MIA	LIA/ER	ER	E/MR	MR	LR	R	R?	PM	PM/MOD
Domestic cattle		3	1		4	1	2			1
Domestic cattle?			1							
Caprine					1					
Pig		3								
Horse				1	1					
Large mammal		53			65	5			1	
<b>Total NISP</b>	0	59	2	1	71	6	2	0	1	1
<b>Total NSP</b>	1	69	13	1	72	6	2	1	1	1

Table 13: Total NISP (Number of Identified Specimens) and NSP (Number of Specimens) figures per period from hand-collected material from the site

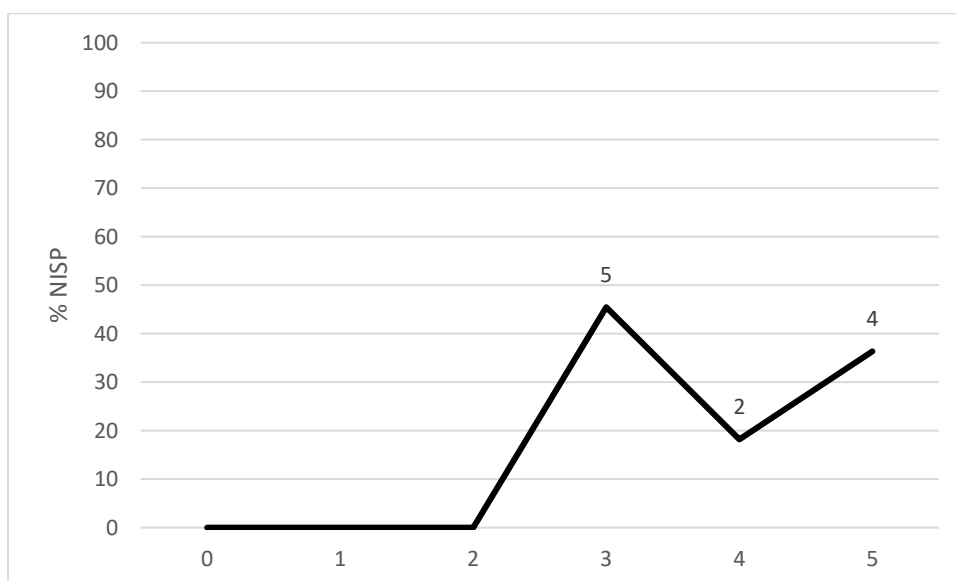

Figure 47: Condition of identified specimens, expressed as a percentage of NISP (following Behrensmeyer 1978)

	Butchery marks	Pathologies	Gnawed	Burnt	Ageing data	Biometric data	Sex
Domestic cattle	1				6		
Horse					2		
<b>Total</b>	1	0	0	0	8	0	0

Table 14: Non-species data recorded from the specimens (NSP) in the assemblage



<b>Context</b>	<b>NSP</b>	<b>Mass (g)</b>
303	3	38
305	2	29
407	1	4
904	1	4
3912	3	140
3926	12	25
3928	1	1
4003	1	5
4006	69	240
4008	2	127
4108	53	26
4206	1	36
4207	1	3
4215	1	3
4301	1	1
4508	1	32
4515	4	21
4518	13	35
5712	3	7
7404	1	244

Table 15: Total NSP and weight of specimens from each context

## Appendix D      References

---

- ACBMG. (2007). *Ceramic building material, minimum standards for recovery, curation, analysis and publication* .
- Anderson-Whymark, H. (2015). *The flint*, in Allen, T, Barclay, A, Cromarty, A, M, Anderson-Whymark, H, Parker, A, Robinson, M, and Jones, G, *Opening the wood, making the Land; The Archaeology of a Middle Thames Landscape, Mesolithic, Neolithic and Bronze Age*. Oxford Archaeological Unit, TVLM 38.
- Atkinson, D, and Oswald, A. (1969). London clay tobacco pipes. *Journal of the British Archaeological Association* 32, 171-227.
- Bamford, H. (1985). *Briar Hill: excavation 1974-1978, Northampton* . Northampton Development Corporation. Archaeological monograph 3.
- Bayley, J, and Butcher, S. (2004). Roman Brooches in Britain, A Technological and Typological Study based on the Richborough Collection. *Society of Antiquaries Research Report No. 68*.
- Behrensmeyer, A. K. (1978). Taphonomic and Ecologic Information from Bone Weathering. *Paleobiology*, 4 (2), 150–162.
- Biddulph, E., Foreman, S., Stafford, E., Stansbie, D. and Nicholson, R. (2012). *London Gateway. Iron Age and Roman salt making in the Thames Estuary: Excavation at Stanford Wharf Nature Reserve, Essex*. Oxford: Oxford Archaeology monograph 18.
- Booth, P. (2016). *Oxford Archaeology Roman pottery recording system: An introduction, unpublished*.
- Bradley, P. (1999). *The worked flint*. In A. Barclay and C. Halpin. Eds. *Excavations at Barrow Hills, Radley, Oxfordshire* . Oxford: Oxford Archaeological Unit. Thames Valley Landscapes Monograph 11: 211-227.
- British Geological Survey. (2019). *Geology of Britain Viewer*. Retrieved from <http://mapapps.bgs.ac.uk/geologyofbritain/home.html>
- Brodribb, G. (1987). *Roman brick and tile*.
- Brown, N and Medleycott, M. (2013). The Neolithic and Bronze Age Enclosures at Springfield Lyons Essex: 1981-1991. *East Anglian Archaeology*.
- Brown, N. (1998). Earlier Iron Age pottery, in G A Carter, *Excavations at the Orsett 'Cock' Enclosure, Essex, 1976*, . *East Anglian Archaeology* 86 , 88-9.
- Buikstra, J E, and Ubelaker, D H. (1994). Standards for data collection from human skeletal remains. *Arkansas Archaeological Survey Research Series* 44.
- Carter, G. A. (1998). *Excavations at the Orsett 'Cock' Enclosure, Essex, 1976*. Essex County Council: East Anglian Archaeology 86.

- Chartered Institute for Archaeologists (CIfA). (2014a). *Standard and Guidance for Archaeological Evaluation*. Retrieved from:  
<http://archaeologists.net/sites/default/files/node-files/IfASG-Evaluation.pdf>
- Chartered Institute for Archaeologists (CIFA). (2014b). *Standard and Guidance for the Creation, Compilation, Transfer and Deposition of Archaeological Archives*.
- Department for Communities and Local Government (DCGL). (2018). *National Planning Policy Framework*. London: Her Majesty's Stationary Office.
- Dewey, H, and Bromehead, C E N. (1915). *The geology of the country around Windsor and Chertsey*.
- Essex County Council, Historic Environment Branch. (2010). *The Greater Thames Estuary Historic Environment Research Framework: Part 1 Update and Revision of the Archaeological Research Framework for the Archaeological Research Framework for the Greater Thames Estuary 1999*. London: Greater Thames Estuary Archaeological Steering Committee.
- Evans, C, Appleby, G, and Lucy, S. (2016). Lines in the Land: Mucking Excavations by Margaret and Tom Jones, 1965-1978. Prehistory: context and summary. *Cambridge Archaeological Unit Archives Series: Historiography and Fieldwork 2/Mucking 6*.
- Gibson, M, Boston, C, Clough, C, and Marquez-Grant, N. (2012). *Human remains. In T G Allen, A Bates and J Collins A Road Through the Past: archaeological discoveries on the A2 Pepperhill to Cobham road-scheme in Kent*. Oxford Archaeology Monograph 16.
- Going, C. J. (1987). The Mansio and other sites in the south-eastern sector of Caesaromagus: the Roman pottery . *CBA Research Report No 62*.
- Harding, P. (1990). *The worked flint, in The Stonehenge environs project, (ed J C Richards)* . English Heritage.
- Healy, F. (1988). *The Anglo-Saxon Cemetery at Spong Hil, North Elmham, Part VI: Occupation during the seventh to second Millennia BC*. East Anglian Archaeological reports 38.
- Hedges, J and Buckley, D. (1978). Excavations at a Neolithic Causewayed Enclosure, Orsett, Essex, 1975. *Proceedings of the Prehistoric Society 44*, 219-308.
- Highways England. (2018). *Lower Thames Crossing: A Scheme Wide Specification for Archaeological Trial Trenching: unpublished document HE540039-CJVGEN- GEN-SPE-HER-00001draft, Revision 1.05*.
- Historic England. (2011). *Environmental Archaeology. A guide to the theory and practice of methods, from sampling and recovery to post-excavation (2nd edition)*. Centre for Archaeology guidelines.
- Historic England. (2015). *Management of Research Projects in the Historic Environment: The MoRPHE Project Managers' Guide*. Swindon: Centre for Archaeology Guidelines.

- Historic England. (2018). *The Role of the Human Osteologist in an Archaeological Fieldwork Project*.
- Inizan, M. L, Reduron-Ballinger, M, Roche, H and Tixier, J. (1999). *Technology and terminology of knapped stone*. Cercle de Recherches et d'Etudes Préhistoriques, CNRS, Nanterre.
- Jones, M. U and Rodwell, W. (1973). The Romano-British Pottery Kilns at Mucking, in *Essex Archaeology and History Trans Essex Archaeol Soc* 5, 13-47.
- Lucy, S., & Evans, C. (2016). *Romano-British Settlement and Cemeteries. Mucking Excavations by Margaret and Tom Jones, 1965-1978*. Oxford: Oxbow.
- McKinley, J. I. (1989). Cremations: expectations, methodologies and realities. In C Roberts, F Lee and J Bintliff (eds) *Burial Archaeology – Current Research, Methods and Developments. BAR Report 211*.
- McKinley, J. I. (2000). *Cremation burials. In B Barber and D Bowsher, The Eastern Cemetery of Roman London. Excavations 1983-1990*. MoLAS Monograph 4, 264-277.
- McKinley, J. I. (2004). Compiling a skeletal inventory: cremated human bone, in: M Brickley and J I McKinley (eds.), *Guidelines to the Standards for Recording Human Remains, IFA Paper No. 7, BABA0 and IFA: Southampton and Reading: 9-13*.
- McKinley, J. I. (2006). *Cremation...the cheap option? In C Knusel and R Gowland (eds) The Social Archaeology of Funerary Remains*. 81-8.
- McKinley, J. I. (2013). *Cremation: excavation and analysis. In S Tarlow and L Nilsson Stutz (eds) The Oxford Handbook of the Archaeology of Death and Burial* . 147-72.
- Medlycott, M ed. (2011). *Research and Archaeology Revisited: a Revised Framework for the East of England*. East Anglian Archaeology Occasional Paper 24: Association of Local Government Archaeological Officers.
- Onhuma, K and Bergman, C A,. (1982). Experimental studies in the determination of flake mode, *Bulletin of the Institute of Archaeology, London* 19, 161-171.
- Oxford Archaeology. (2019a). *Lower Thames Crossing Scheme-wide Written Scheme of Investigation for Trial Trenching south of the River Thames*.
- Oxford Archaeology. (2019b). *Lower Thames Crossing Scheme-wide Written Scheme of Investigation for Trial Trenching north of the River Thames*.
- Oxford Archaeology. (2019c). *Lower Thames Crossing Detailed Written Scheme of Investgtion for Trial Trenching of Land Parcel 3*. Oxford Archaeology.
- Oxford Archaeology. (2020). *Lower Thames Crossing. Archaeological Evaluation Report for Trial Trenching of Land Parcel 1. Masons Corner, Heath Road, Orsett Heath, Essex*.

- Place Services. (2019). *Lower Thames Crossing Aerial Investigation and Mapping Report*, Essex County Council.
- Serjeantson, D. (1996). *Animal Bone*. In: Needham, S. and Spence, T. (Eds). *Runnymede Bridge Research Excavations, Volume 2: Refuse and Disposal at Area 16 East, Runnymede*. 194–223.
- Shaffrey, R. (2012). *Specialist report 9: Ceramic Building Material in London Gateway: Iron Age and Roman salt making in the Thames Estuary. Excavation at Stanford Wharf Nature Reserve, Essex (E Biddulph, S Foreman, E Stafford, D Stansbie and R Nicholson)*. Oxford Archaeology Monograph 18.
- Tomber, R, and Dore, J., (1998). *The National Roman Fabric Reference Collection*.
- Warry, P. (2006). Tegulae manufacture, typology and use in Roman Britain . *BAR British Series 417*.
- Wilkinson, T. J. (1988). *Archaeology and Environment in South Essex: Rescue Archaeology on the route of the A13 Grays By-pass, 1979/80*. East Anglian Archaeology 42.
- Young, C. J. (1977). The Roman pottery industry of the Oxford region. *BAR BS 43*.

## Appendix E      Abbreviations and Glossary

---

**ADS Archaeology Data Service.** Digital archaeological archive

**CDM Construction Design Manual.** Health and safety guidance for the construction industry

**CPD Continuing Professional Development**

**CifA Chartered Institute for Archaeologists**

**DBA Desk Based Assessment.** Detailed assessment of archaeology and other aspects of the historic environment

**DCO Development Consent Order**

**EIA Environmental Impact Assessment.** Detailed study of environmental impacts as directed under the The Town and Country Planning (Environmental Impact Assessment) Regulations 2017 following on from EU Directive EIA Directive (85/337/EEC)

**ES Environmental Statement.** The principal environmental report detailing environmental impacts within an EIA

**GPS Global Positioning System**

**HER Historic Environment Record**

**LTC Lower Thames Crossing**

**MCifA Member of the Chartered Institute for Archaeologists**

**MoRPHE Management of Research Projects in the Historic Environment**

**NMP National Mapping Programme.** A study of aerial photographs and digitisation of resulting data into GIS. Originally funded by Historic England

**OASIS Online Access to the Index of archaeological investigations.**

**The OASIS project brings together a number of strategic partners: the Archaeology Data Service, Historic England, Historic Environment Scotland, and the Royal Commission on the Ancient and Historical Monuments of Wales under the umbrella of the University of York**

**OCN Old County Number.** Historic England’s reference for material that is not readily available online and may represent historic archaeological work that consists of paper archives or has yet to be formally reported on

**PINS Planning Inspectorate**

**RAMS Risk Assessment Method Statement**

**SMC Scheduled monument consent**

**TDR Trusted Digital Repository**

**UKIC United Kingdom Institute for Conservation**

**WSI Written Project of Investigation.** A detailed method statement for archaeological work

**WSL – Western Southern Link**

**The Western Southern Link (WSL) is an alternative for Short List Routes 2, 3 and 4 to the south of the River Thames.**

## Appendix F Site Summary Details

---

<b>Site name:</b>	Hornsby Lane
<b>Site code:</b>	LTC3HL19
<b>Grid Reference</b>	TQ 64442 80214
<b>Type:</b>	Evaluation
<b>Date and duration:</b>	7th December 2019 to the 15th January 2020, 3 weeks
<b>Area of Site</b>	22.98ha
<b>Location of archive:</b>	<p>The archive from Land Parcel 3 will form part of the overall trial trenching scheme archive. This will be deposited in a repository consistent with the standards required by the Museums and Galleries Commission following completion of the archaeological phase of this project. This may either be with the local receiving museum in Thurrock or, if no such repositories are available, with a repository for the whole project designated by LTC. LTC retain the overall responsibility for the successful deposition of the project archive.</p> <p>Currently, the archive is held at Oxford Archaeology's head office, Janus House, Osney Mead, Oxford, Oxfordshire, OX2 0ES. Oxford Archaeology will store the archive for LTC for a maximum period of 2 years following the completion of the project. If the storage of the archive at OA's office extends past this period, an extension to the storage period and final deposition timetable will be reviewed by OA and LTC and agreed with the major stakeholders.</p>

### Summary of Results:

Oxford Archaeology was commissioned by Balfour Beatty on behalf of LTC to undertake a trial trench evaluation of Land Parcel 3 of the Lower Thames Crossing Pre-Enabling Works. Land Parcel 3, also known as Hornsby Lane, is located c 100m east of the hamlet of Orsett Heath within the county of Essex and Thurrock unitary authority (NGR 564442 180214). The evaluation comprised the excavation of 116 trenches that were accessible out of a total of 166 trench locations specified in the written scheme of investigation. The fieldwork was completed between the 7th December 2019 and the 15th January 2020.

The evaluation identified the shallow remains of a putative mortuary enclosure in the north-west corner of the site. The ditches associated with this feature survived to a maximum depth of up to 0.23m and contained no dating evidence or other artefactual evidence to inform the interpretation.

Thirty-four sherds of late Neolithic/early Bronze Age pottery were found in a ditch terminus or pit in Trench 18 in western part of the site. The pottery from this feature included large fragments of a beaker vessel.

Several late Bronze Age/early Iron Age features were identified on the site. This included a NW-SE aligned ditch in Trench 42, a north-south aligned ditch in Trench 78 and a possible curvilinear ditch in Trench 114.

A putative Roman settlement was located on the site, with cropmark evidence that extended beyond the evaluation area identifying a large NW-SE aligned enclosure with an associated trackway, internal subdivisions and further enclosures to the south-east. This was confirmed

by the current investigation, which encountered Roman pottery in several of the ditches, along with late Iron Age/early Roman domestic activity in the area of Trenches 39-45. The large, main enclosure with associated trackway was possibly created in the early to mid-Roman period and was then recut several times. It is likely that settlement activity continued in the eastern part of this enclosure (Trenches 39-45) during the middle to later Roman period. Trenches 45 and 47 in the south-eastern part of the enclosure contained several pottery kilns. This settlement appears to have been involved in arable and pastoral farming, crop processing, pottery production and possibly butchery of animals on an industrial scale. This enclosure may have continued in use until the later Roman period. The NW-SE aligned field boundaries and trackway in the southern part of the site were undated but may be contemporary with the main enclosure.

Trenches 40 and 43 in the central, northern part of the site uncovered a colluvial layer and in both cases this layer contained Roman pottery. These trenches are located in an area of dry valley, where the colluvial layer may have acted as a protective layer, preserving this part of the site from truncation from modern arable farming.

The evaluation identified numerous individual features, including a large quarry pit in the north-western corner of the site, although this was undated. In terms of the other pit-like features that were shown as cropmarks, the majority of these were not identified within the trenches and are likely to have been variations in the natural geology. It is also possible that the aerial survey identified pits that may have been shallow and modern ploughing may have wholly truncated these features.

A later post-medieval ENE-WSW field boundary was identified in the eastern part of the site along with a north-south post-medieval trackway. These features may be associated with Heath Place, the farm to the east of Hornby Lane.



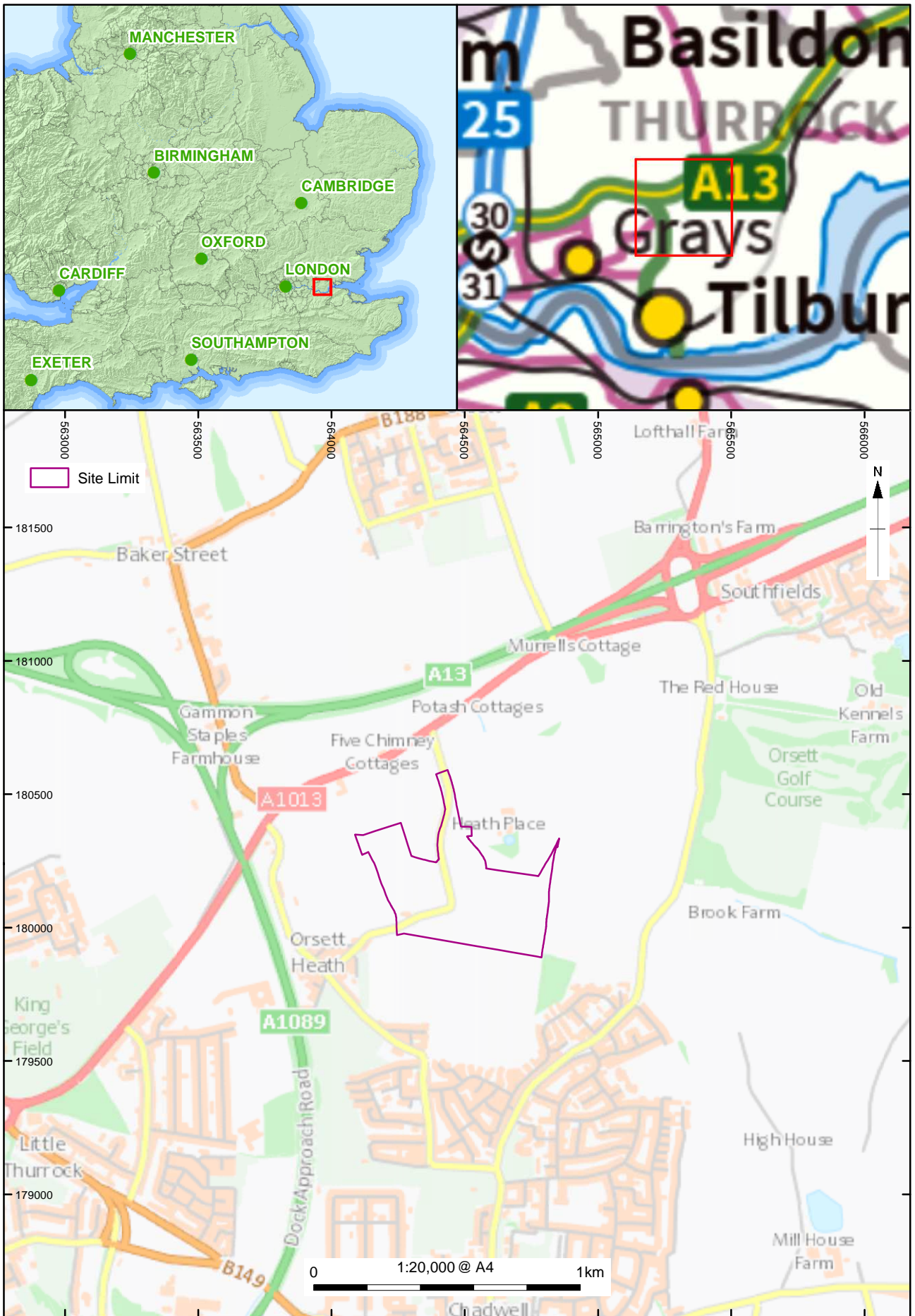

Contains OS data © Crown Copyright and database right 2019

Figure 1: Site location

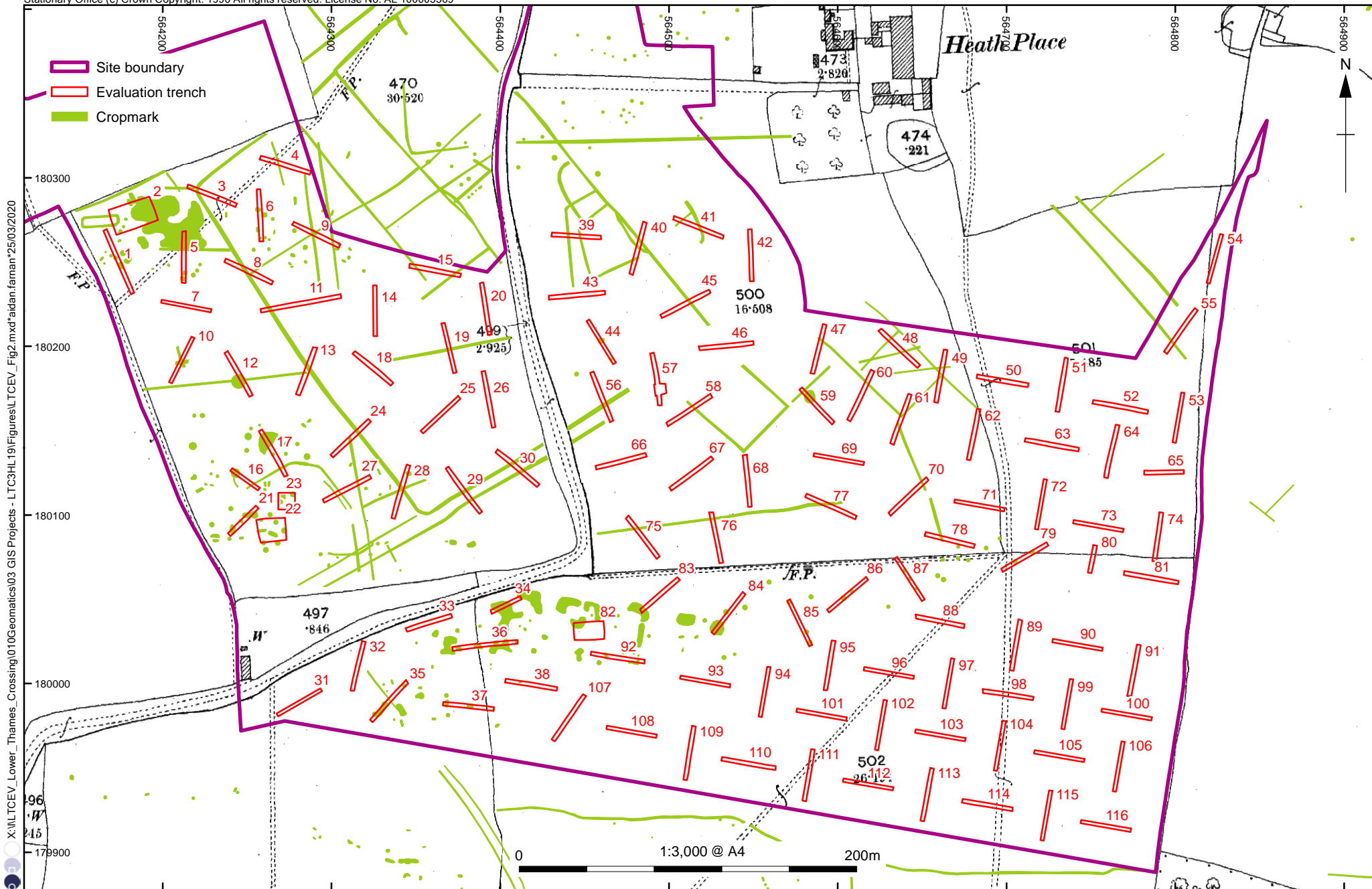

Figure 2: Plan of trench layouts and cropmark features, overlain on the 1st Edition OS map 1897

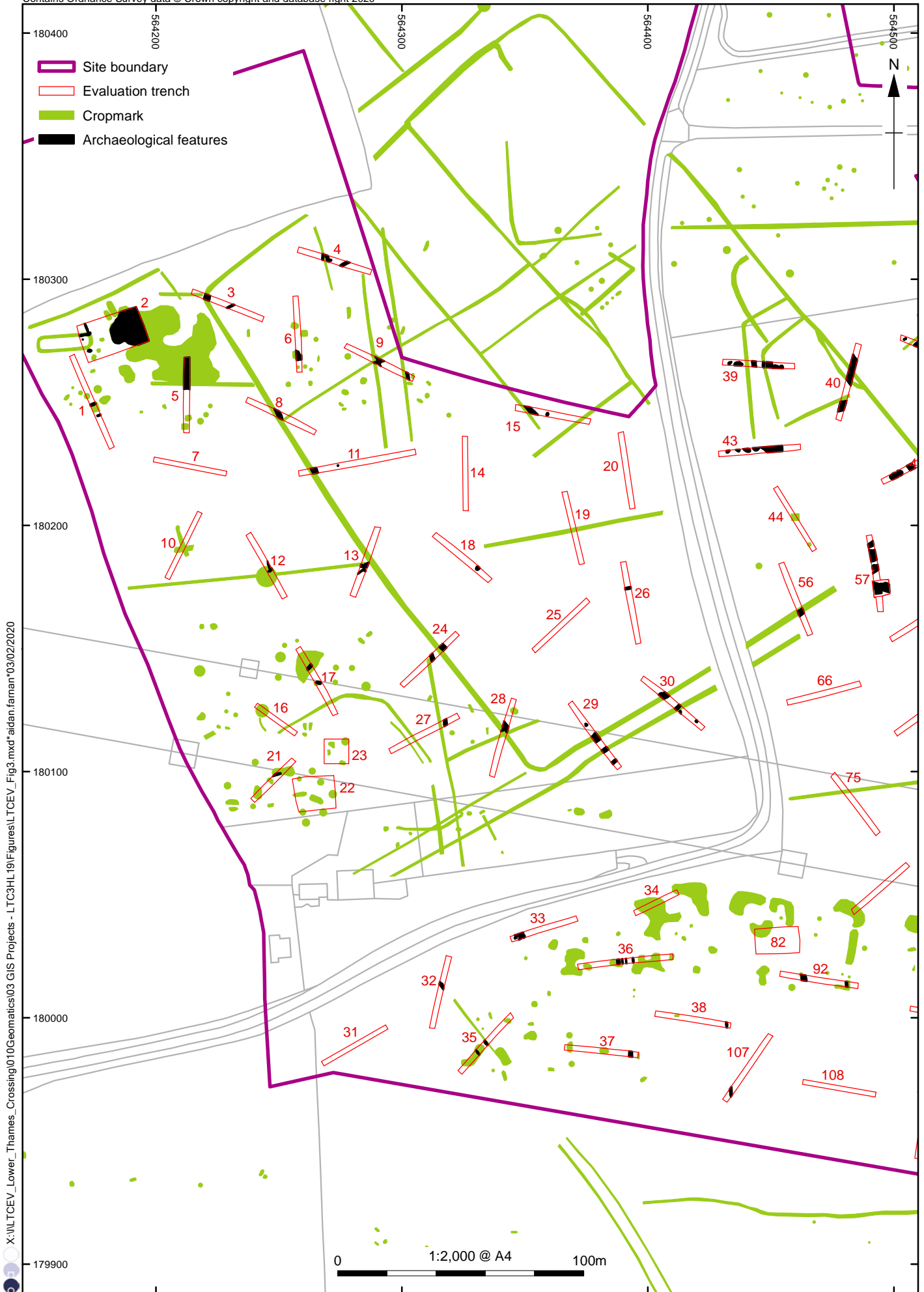

Figure 3: Plan of trench layouts, cropmark features and archaeological features (west)

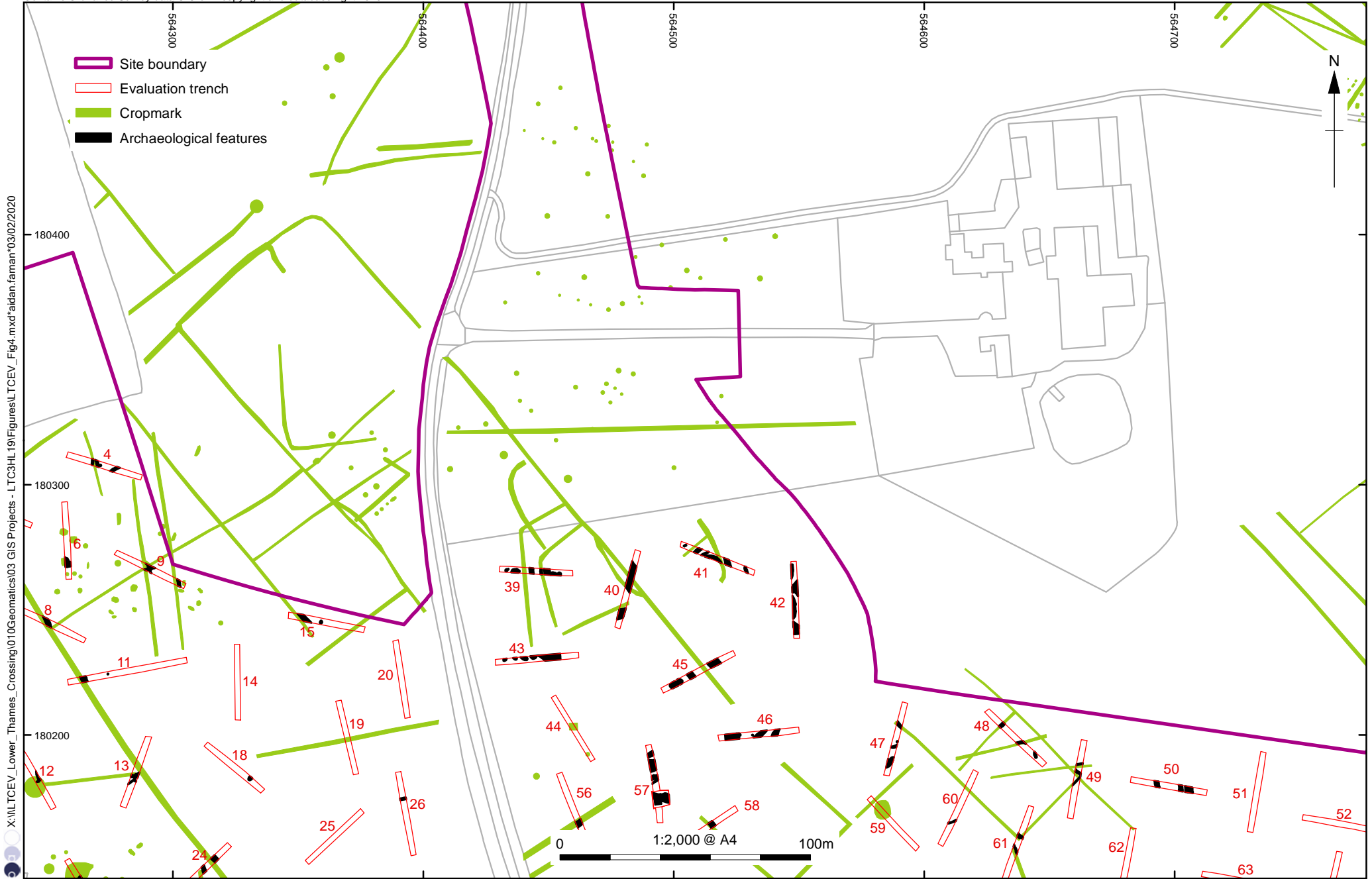

Figure 4: Plan of trench layouts, cropmark features and archaeological features (central north)



Figure 5: Plan of trench layouts, cropmark features and archaeological features (central south)

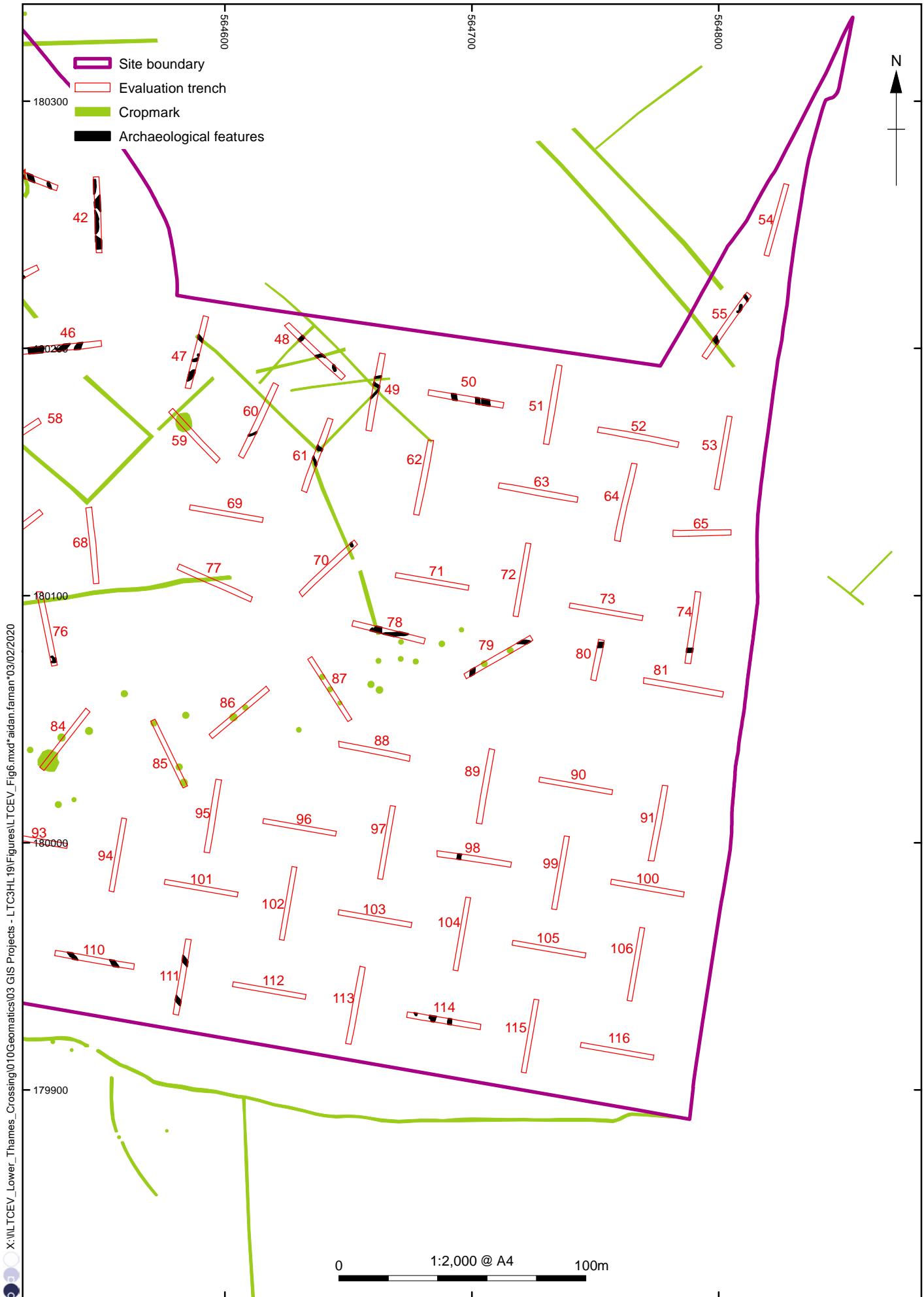
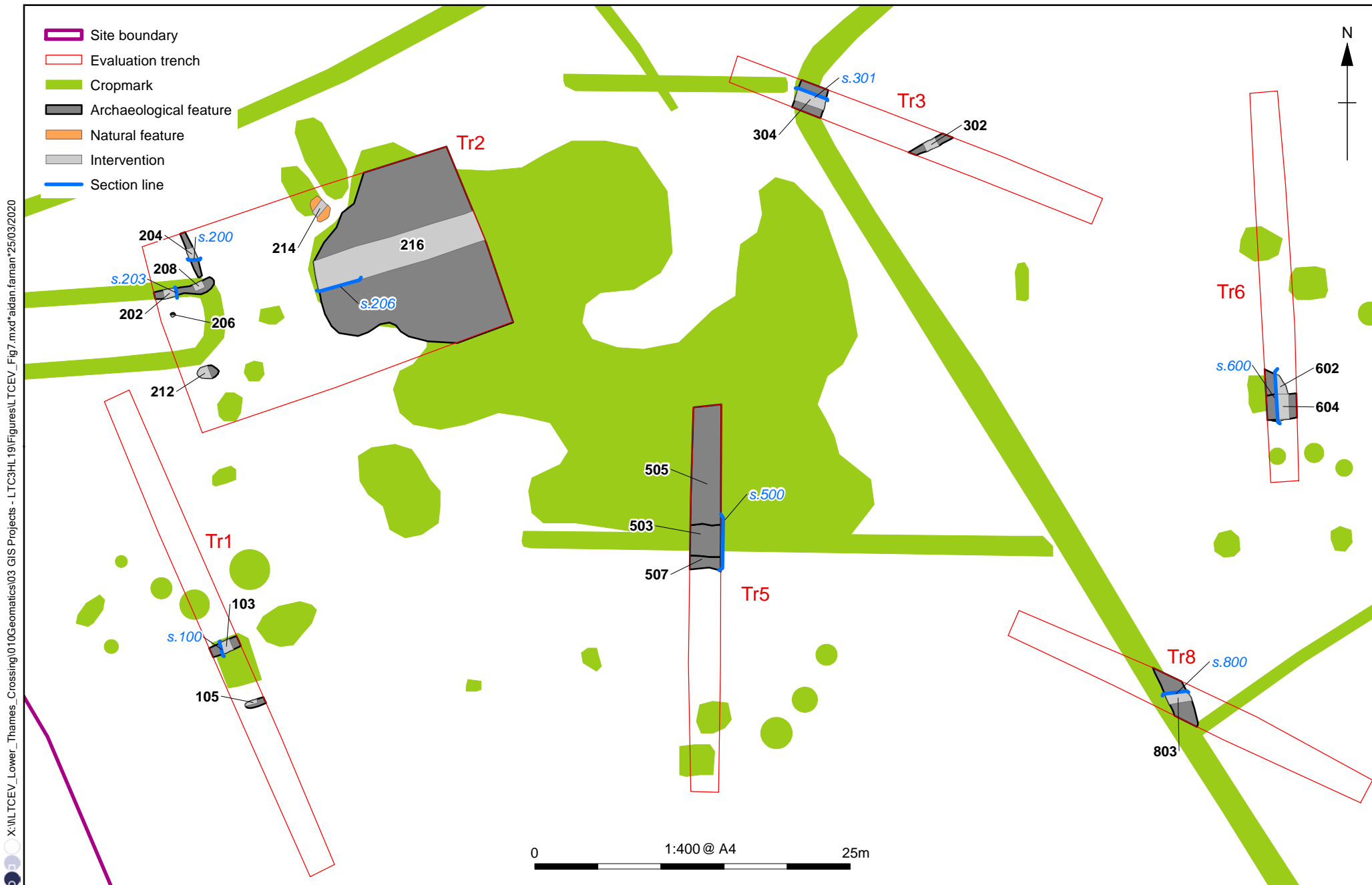

Figure 6: Plan of trench layouts, cropmark features and archaeological features (east)



X:\MLTCEV\_Lower\_Thames\_Crossing\010Geomatics\03 GIS Projects - LTC3HL\19\Figures\LTC3EV\_Fig7.mxd\aidan.farman\25/03/2020

Figure 7: Plan of Trenches 1, 2, 3, 5, 6 and 8

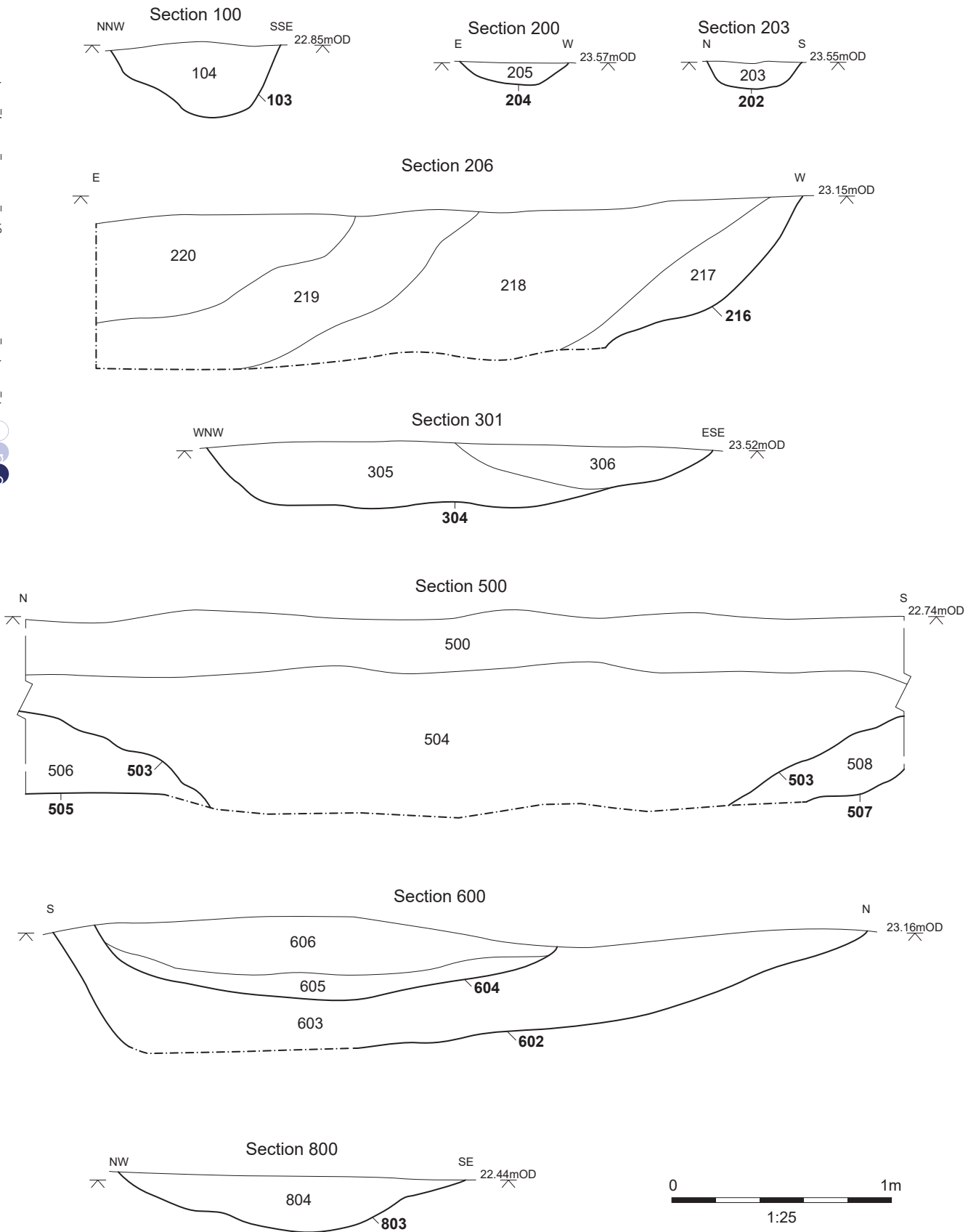

Figure 8: Sections (Trenches 1, 2, 3, 5, 6 and 8)



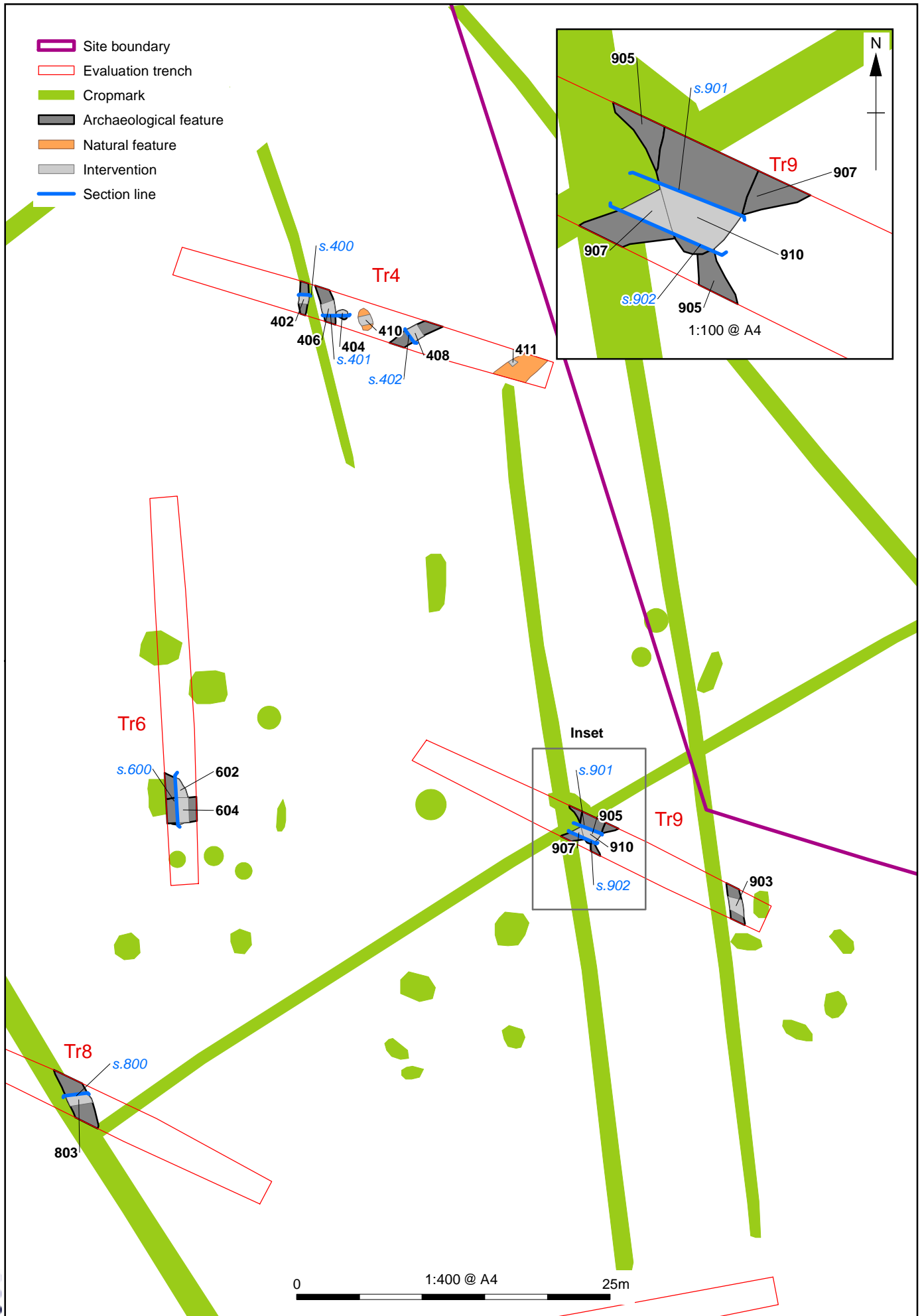

Figure 9: Plan of Trenches 4, 6, 8 and 9

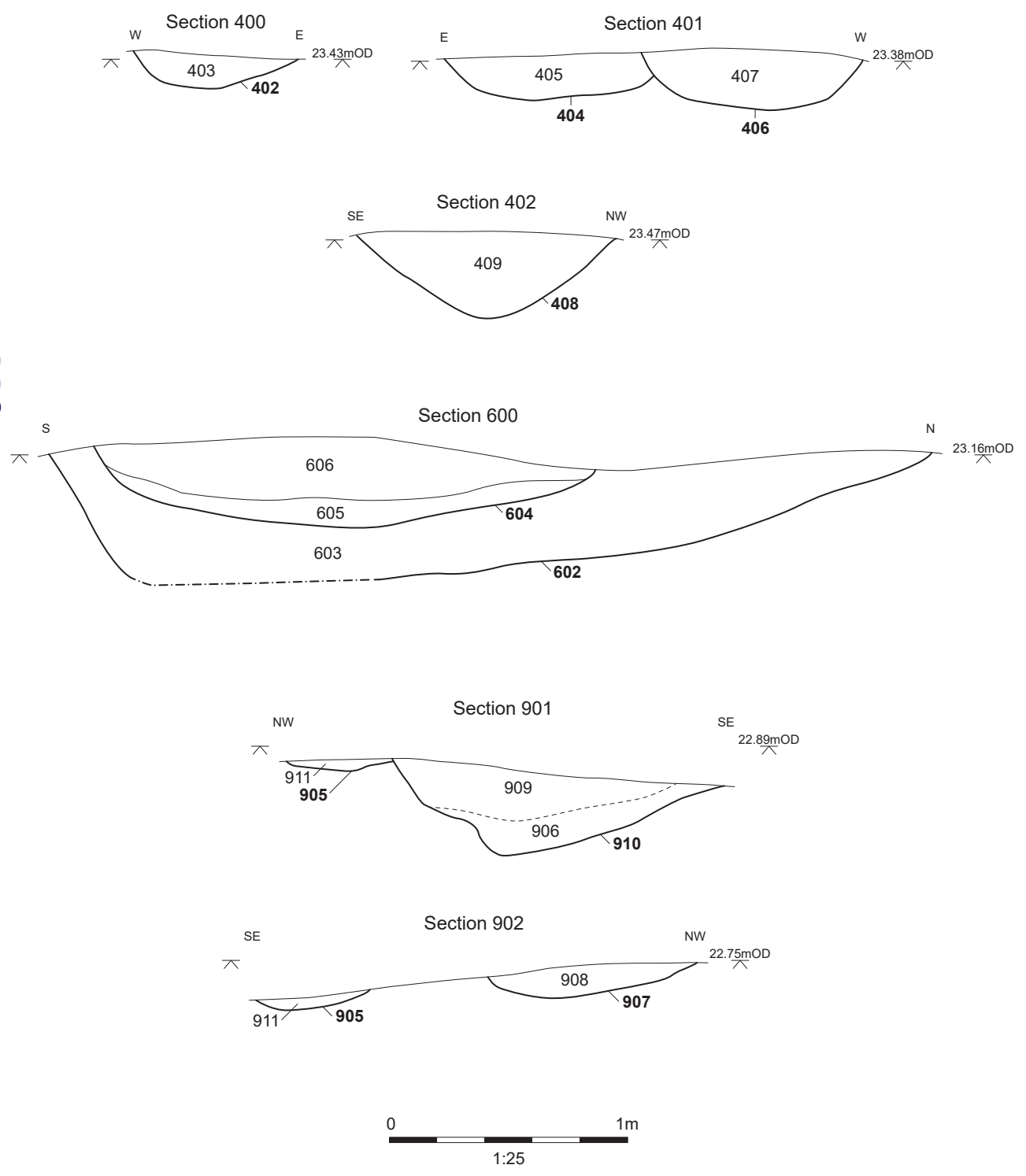

Figure 10: Sections (Trenches 4, 6 and 9)

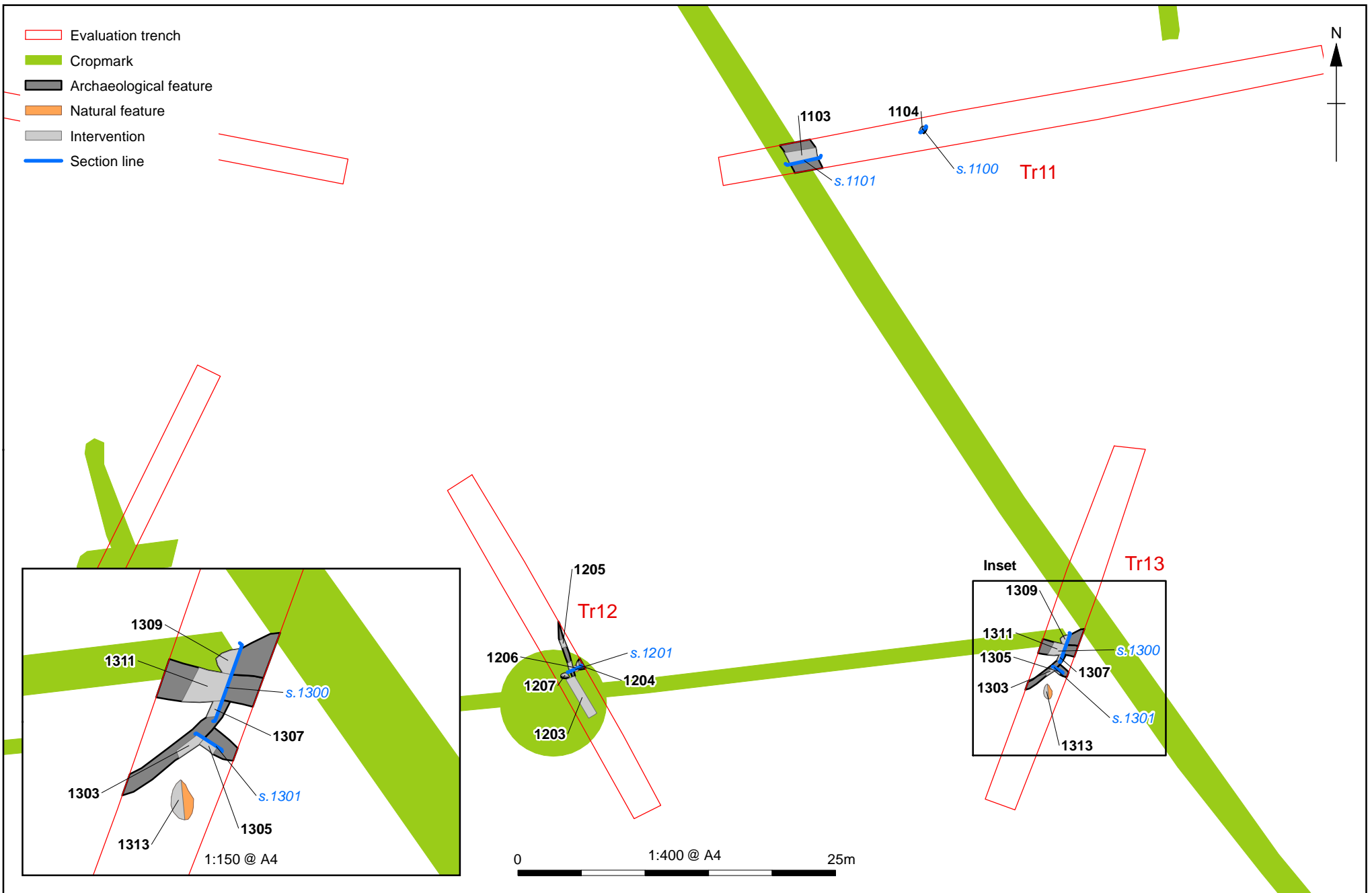

Figure 11: Plan of Trenches 11, 12 and 13

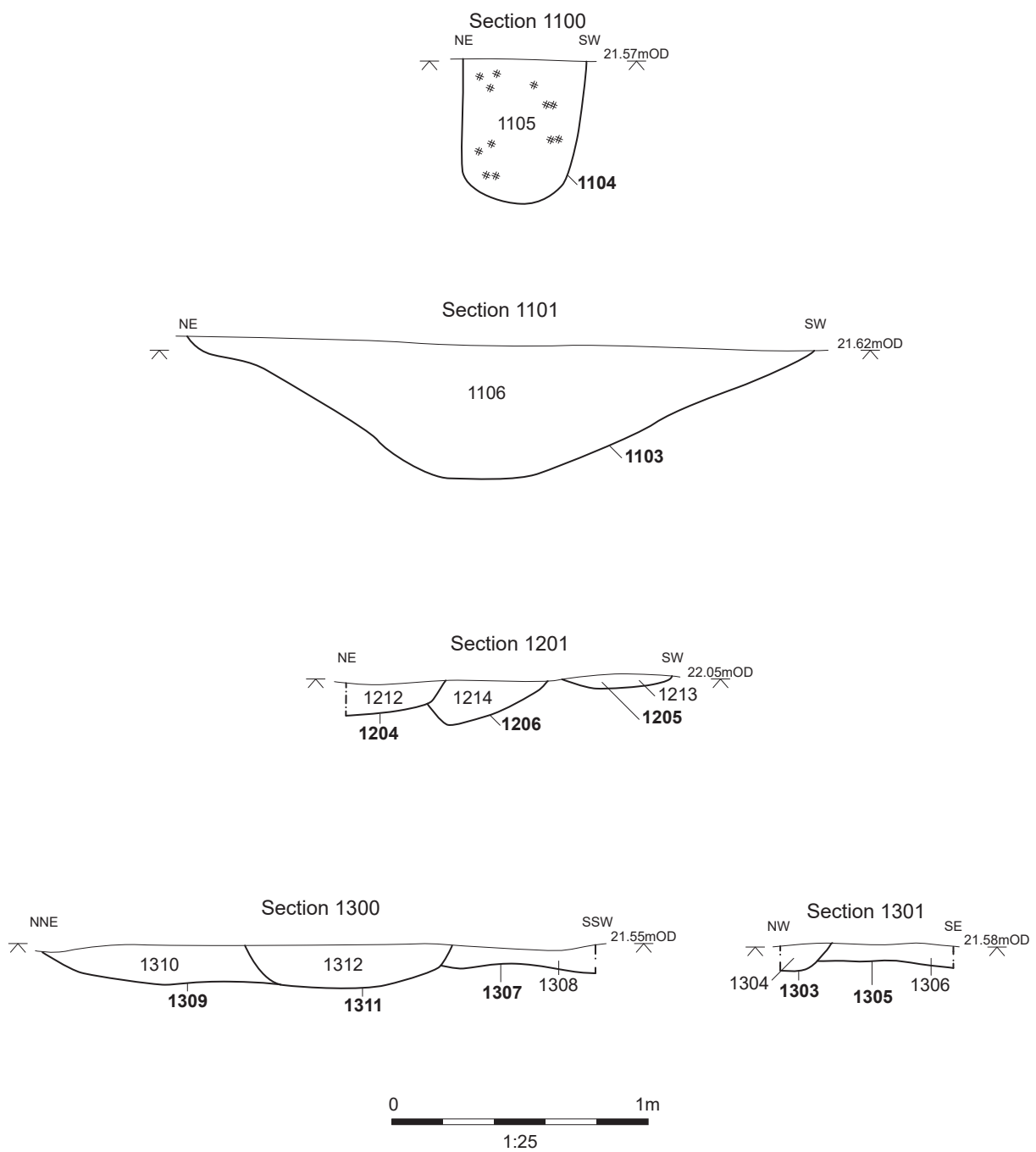

Figure 12: Sections (Trenches 11, 12 and 13)

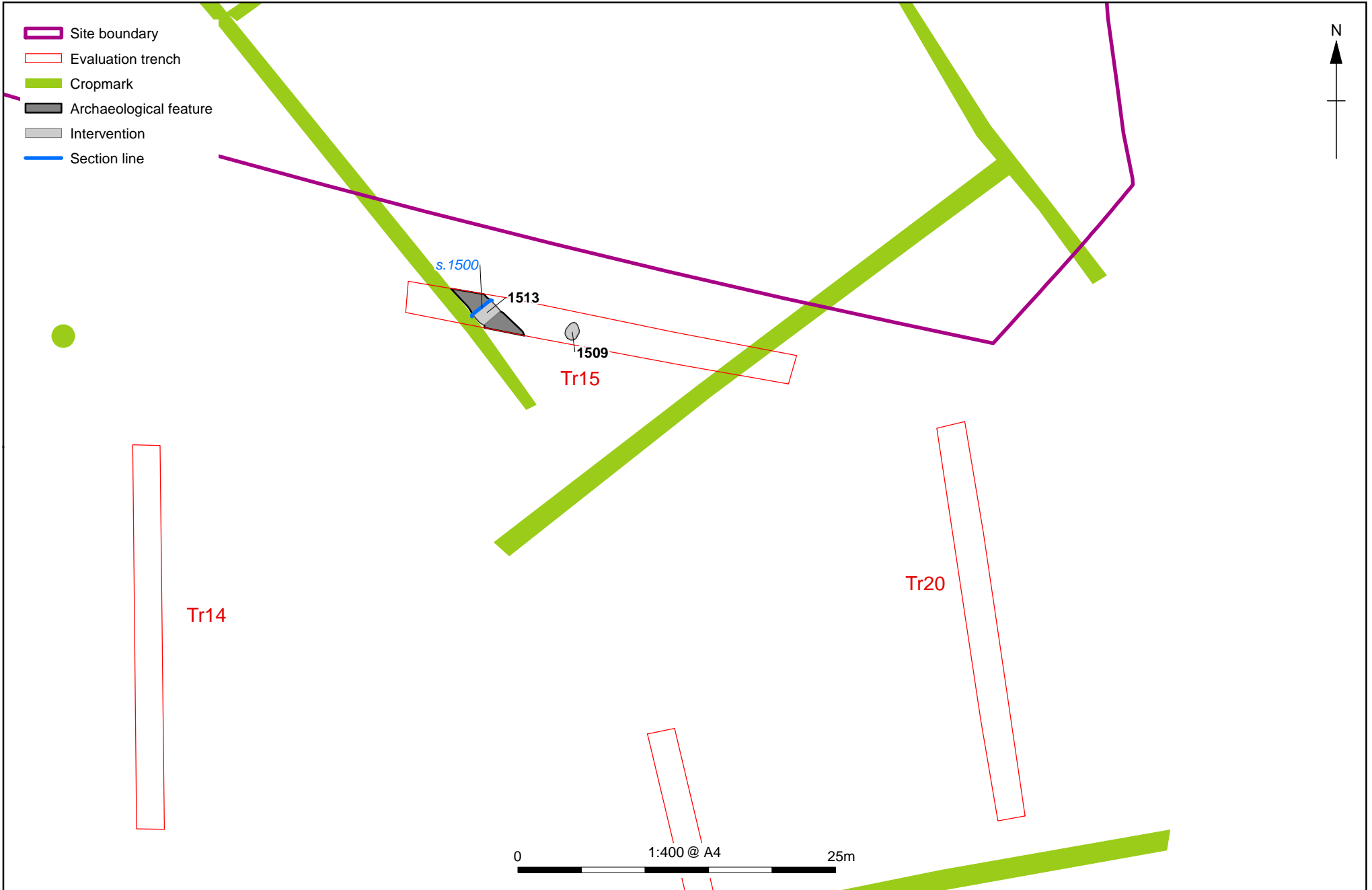

Figure 13: Plan of Trench 15

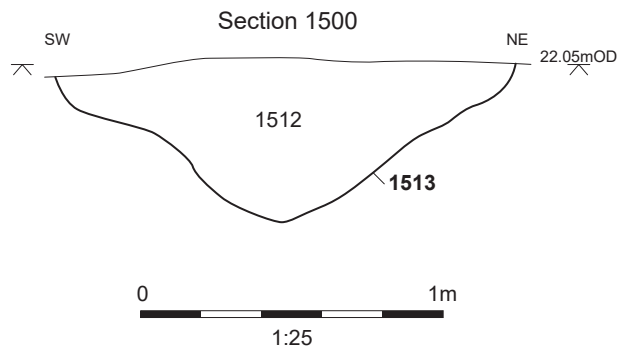

Figure 14: Section (Trench 15)

X:\MLTCEV\_Lower\_Thames\_Crossing\010Geomatics\03 GIS Projects - LTC3HL\19\Figures\LTC3EV\_Fig15.mxd\aidan.faman\03/02/2020

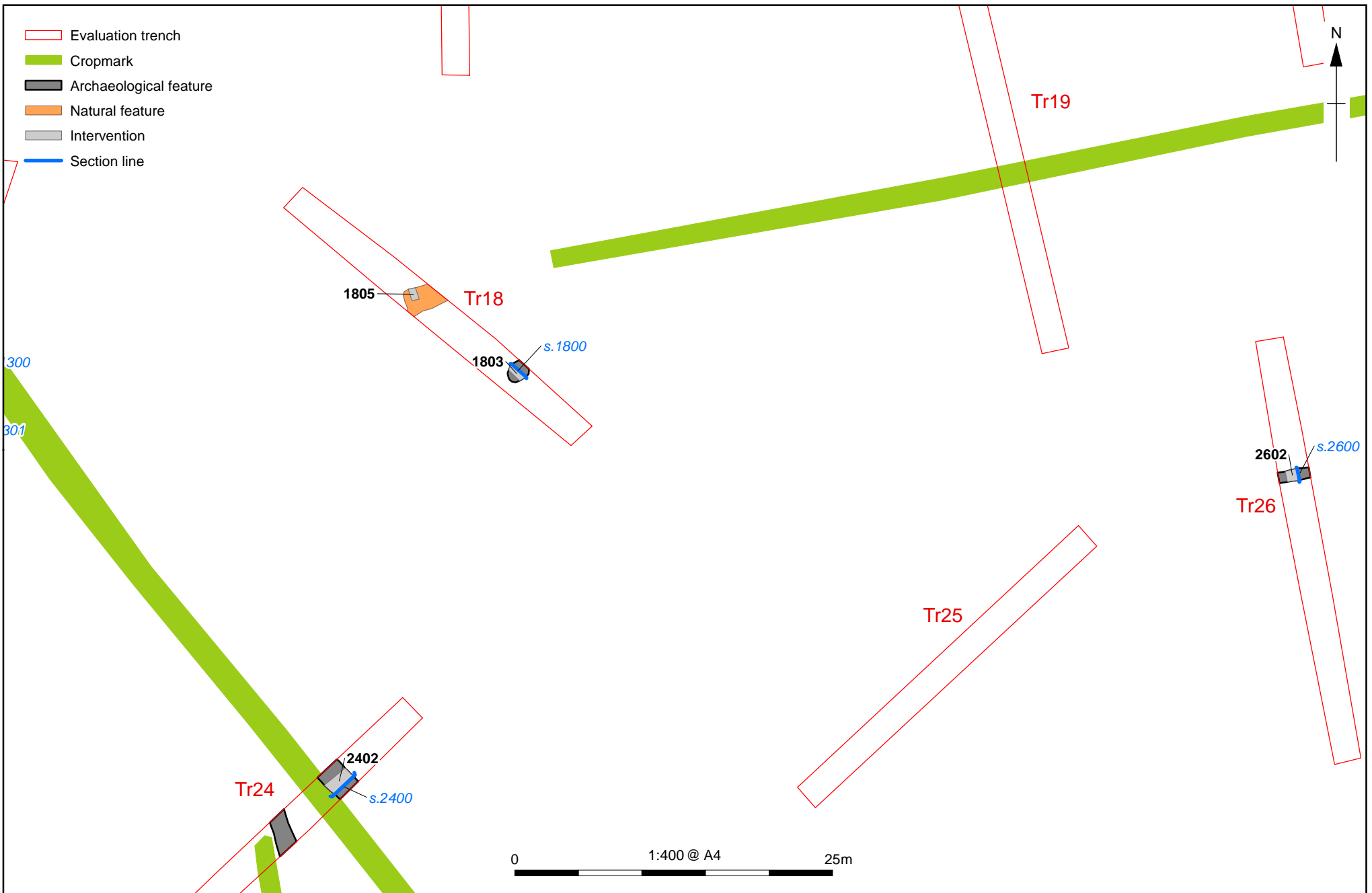

Figure 15: Plan of Trenches 18, 19, 24, 25 and 26

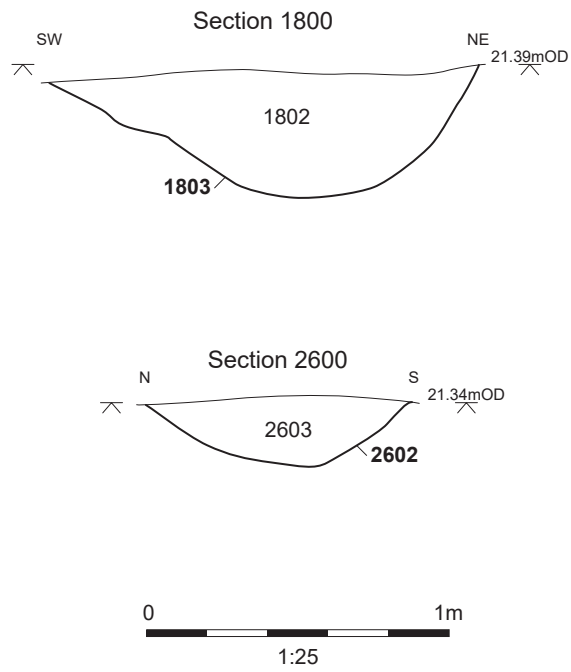

Figure 16: Sections (Trenches 18 and 26)



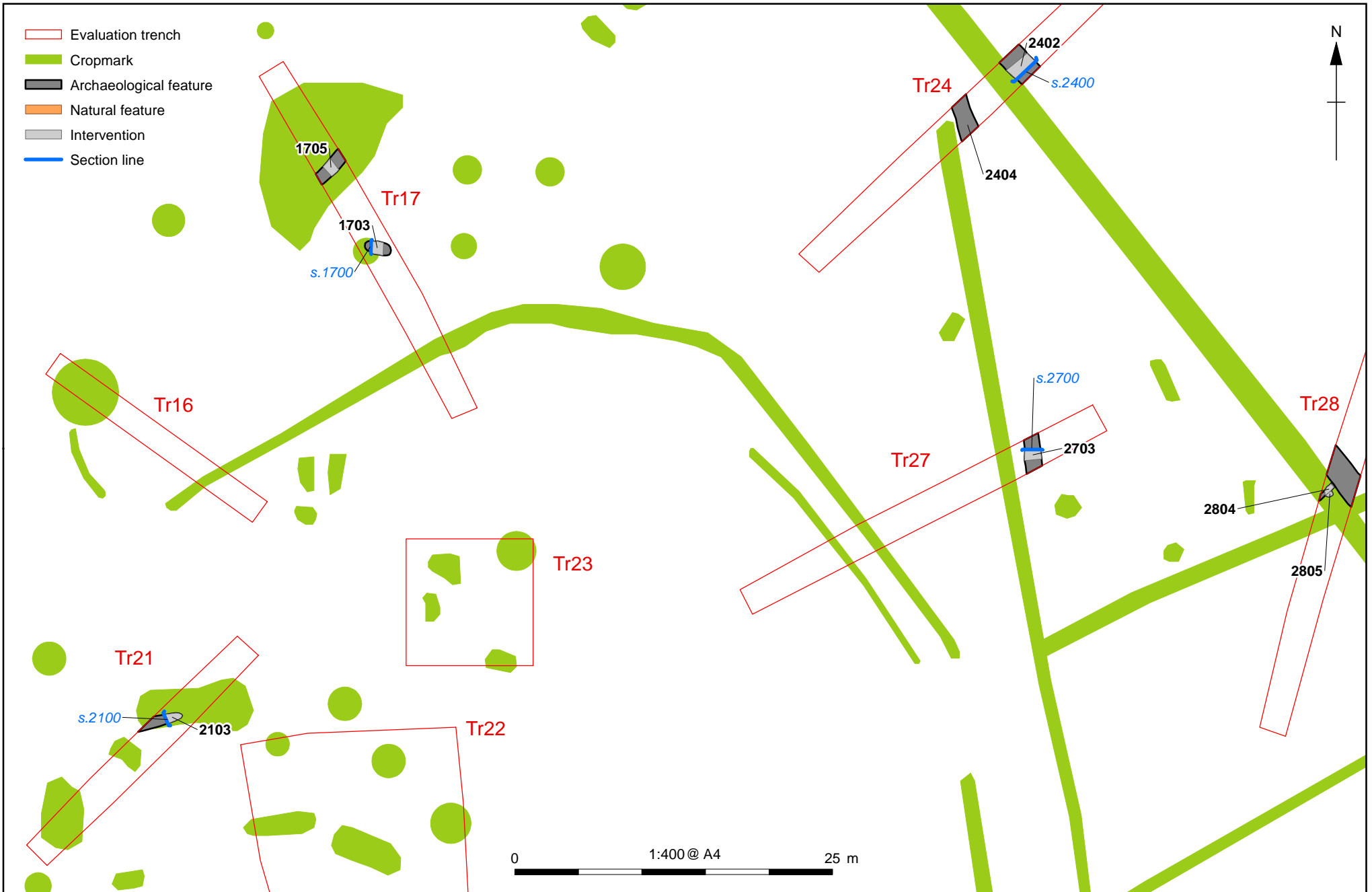

Figure 17: Plan of Trenches 16, 17, 21, 22, 23, 24, 27 and 28

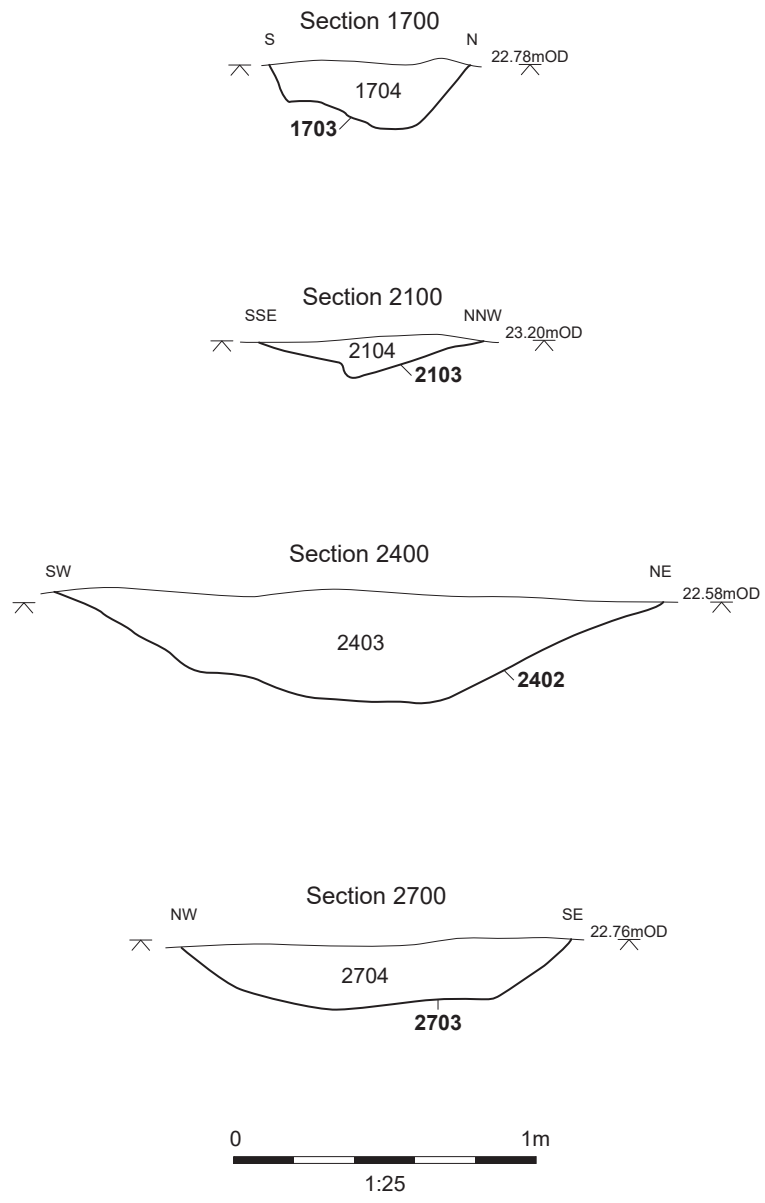

Figure 18: Sections (Trenches 17, 21, 24 and 27)

X:\MLTCEV\_Lower\_Thames\_Crossing\010Geomatics\03 GIS Projects - LTC3HL19\Figures\LTC3EV\_Fig19.mxd\aidan.faman\25/03/2020

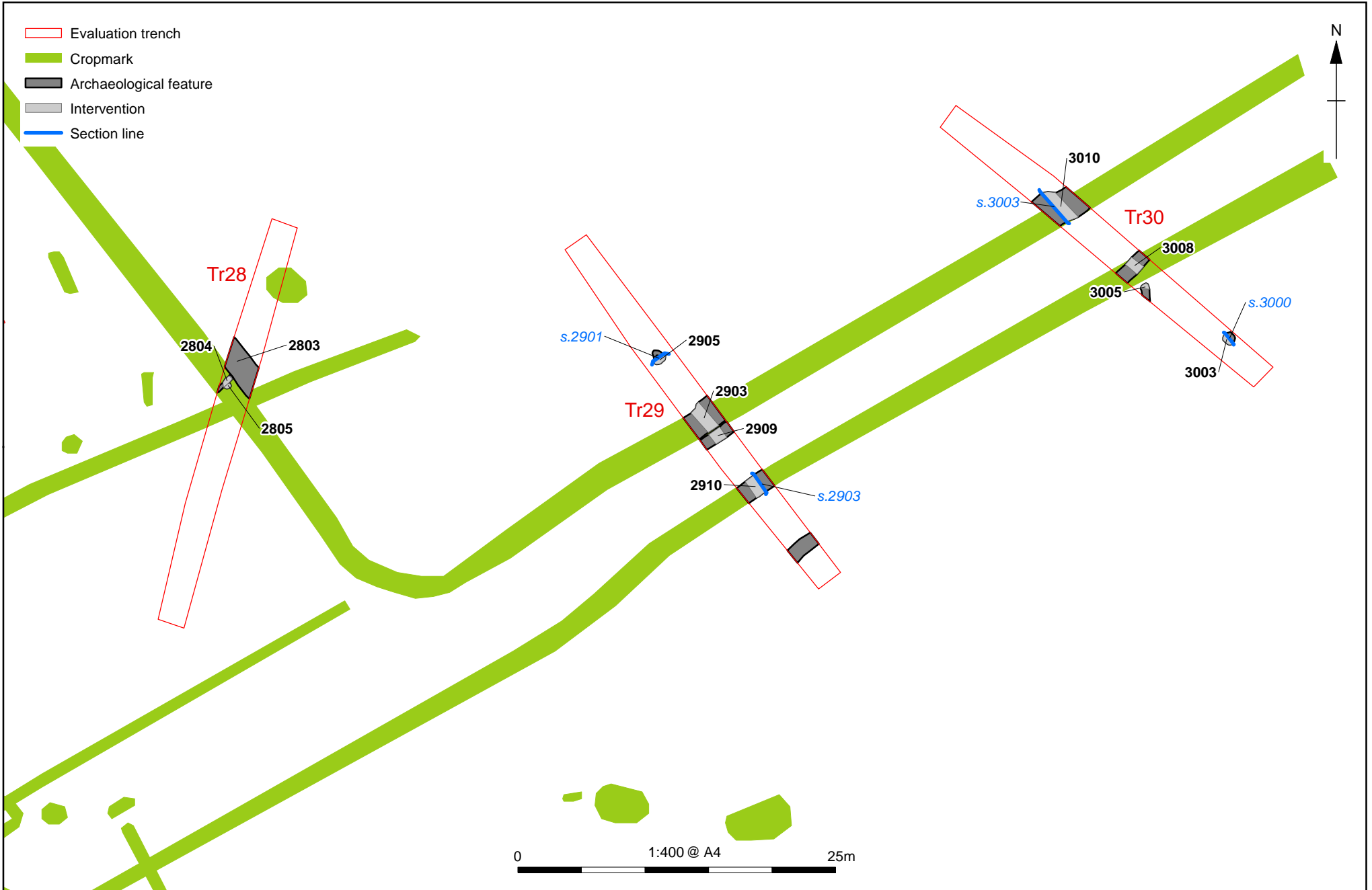

Figure 19: Plan of Trenches 28, 29 and 30

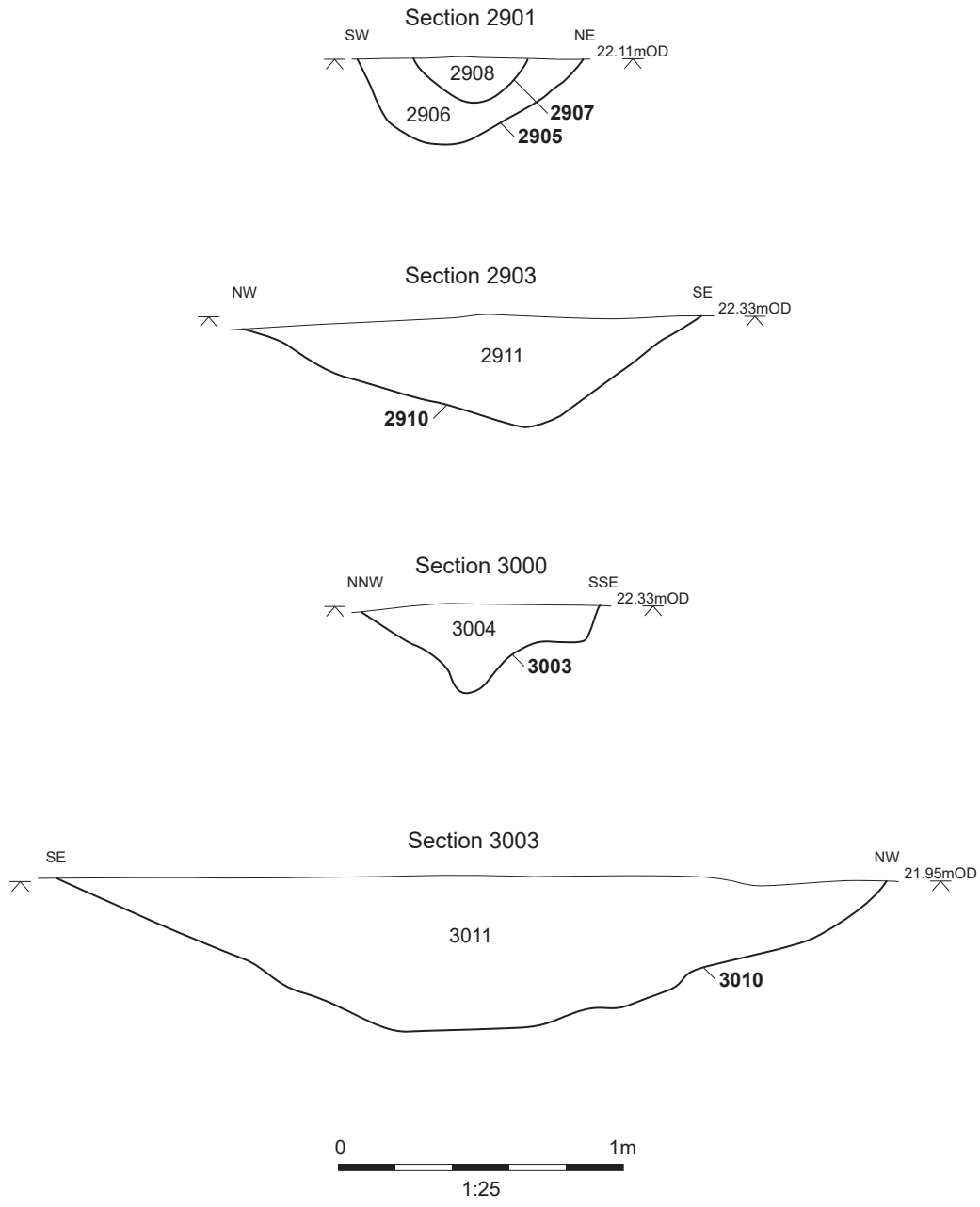

Figure 20: Sections (Trenches 29 and 30)

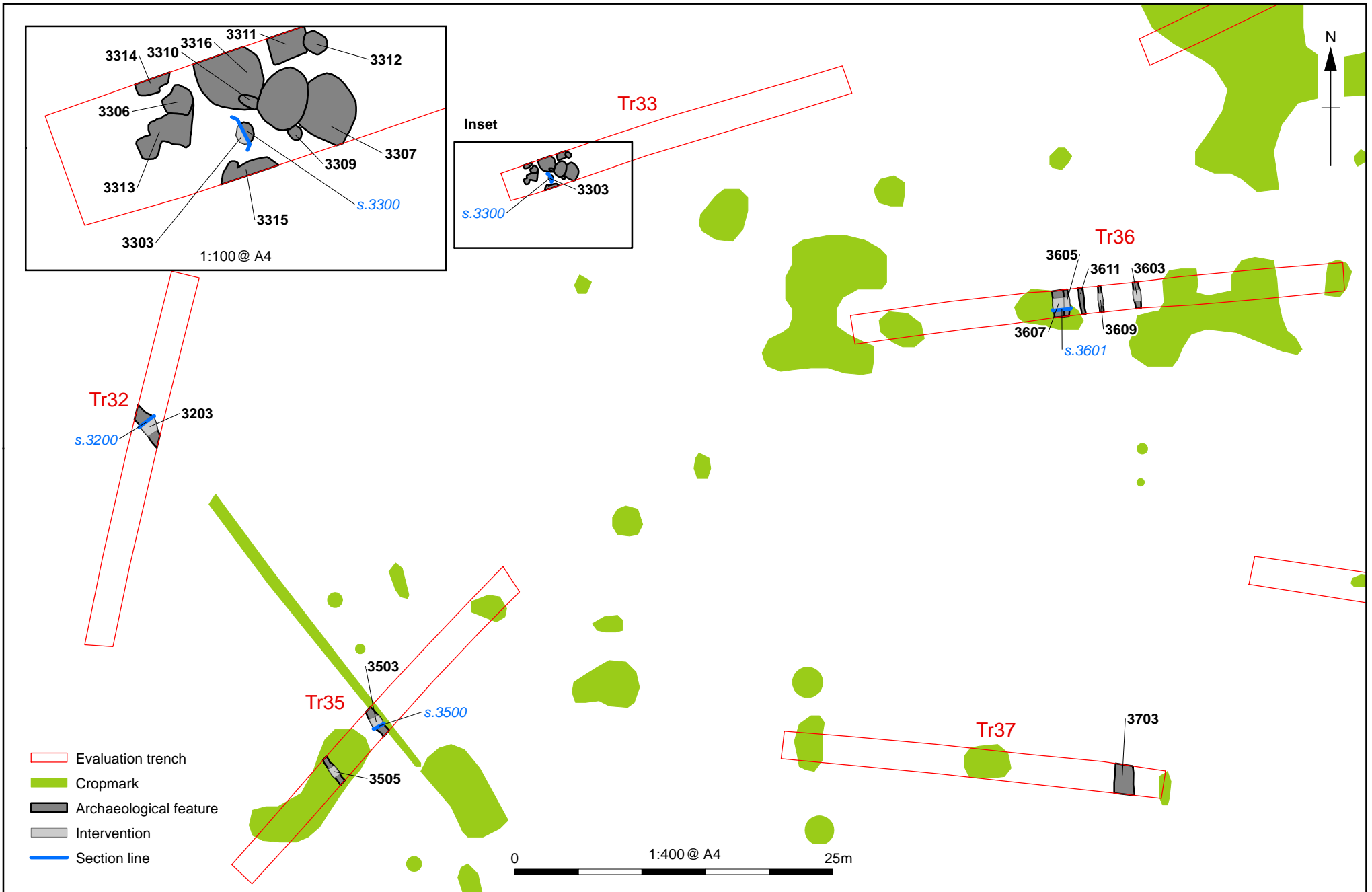

Figure 21: Plan of Trenches 32, 33, 35, 36 and 37

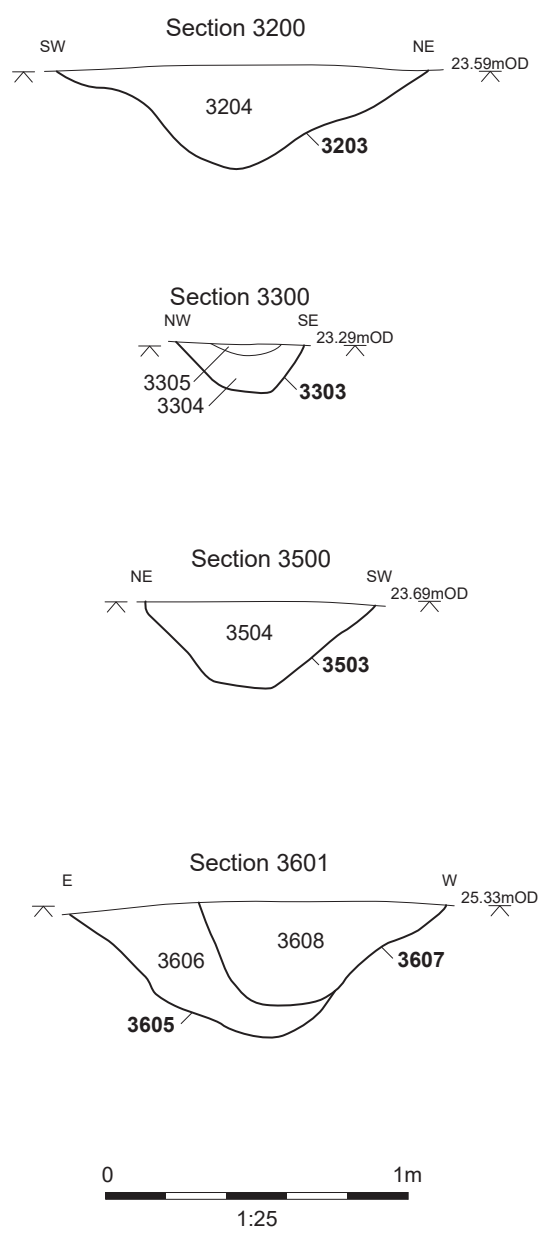

Figure 22: Sections (Trenches 32, 33, 35 and 36)

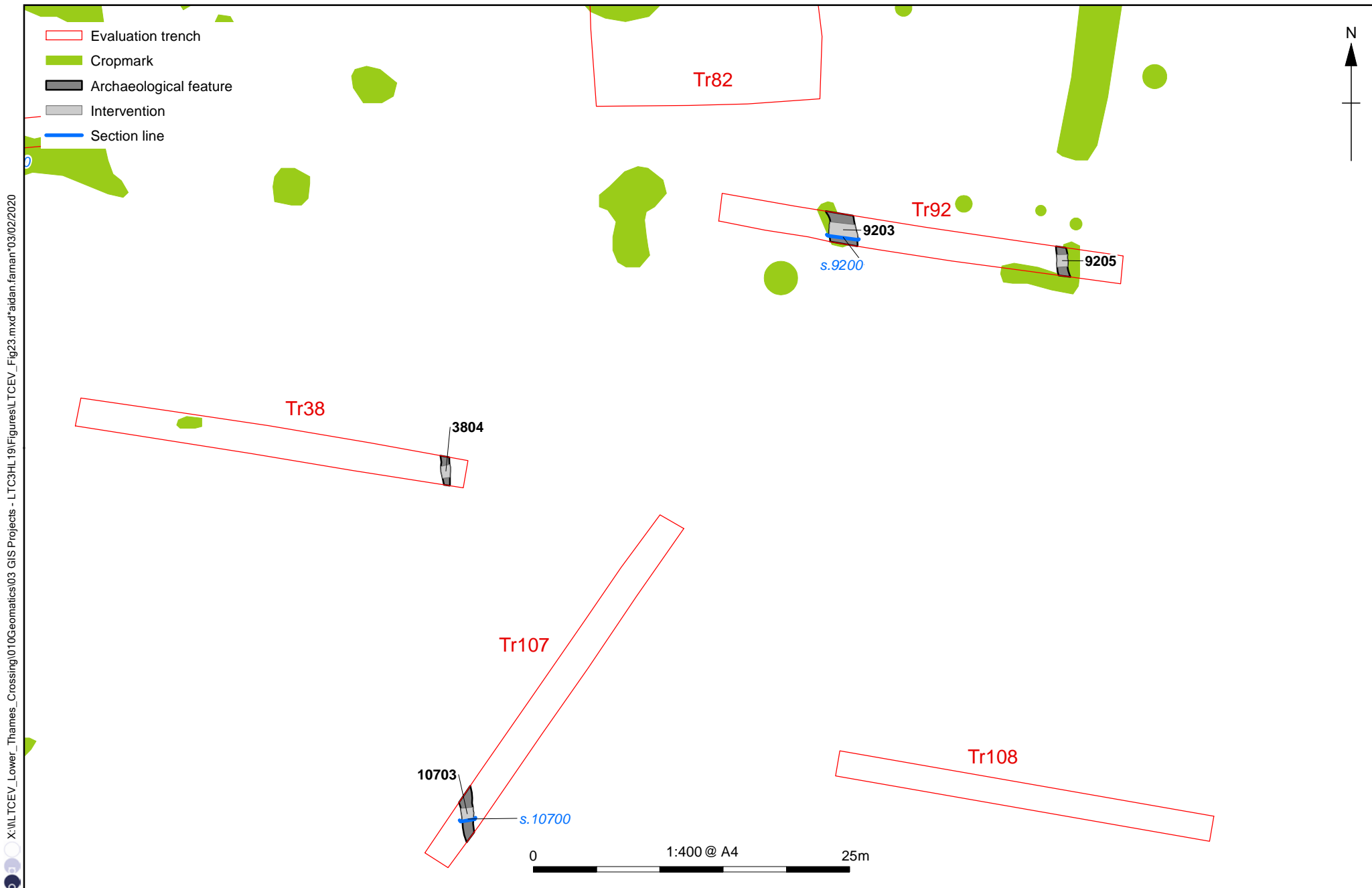

Figure 23: Plan of Trenches 38, 92, 107 and 108

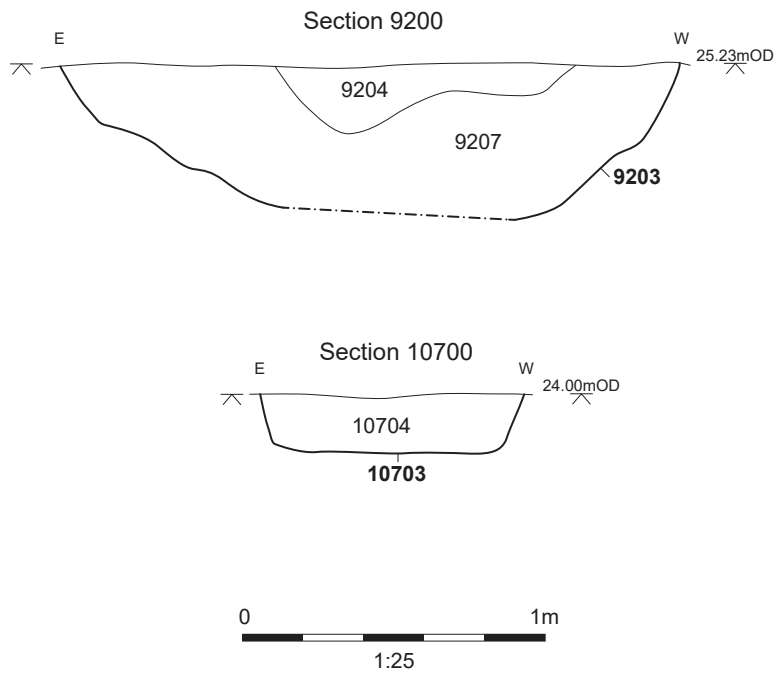

Figure 24: Sections (Trenches 92 and 107)



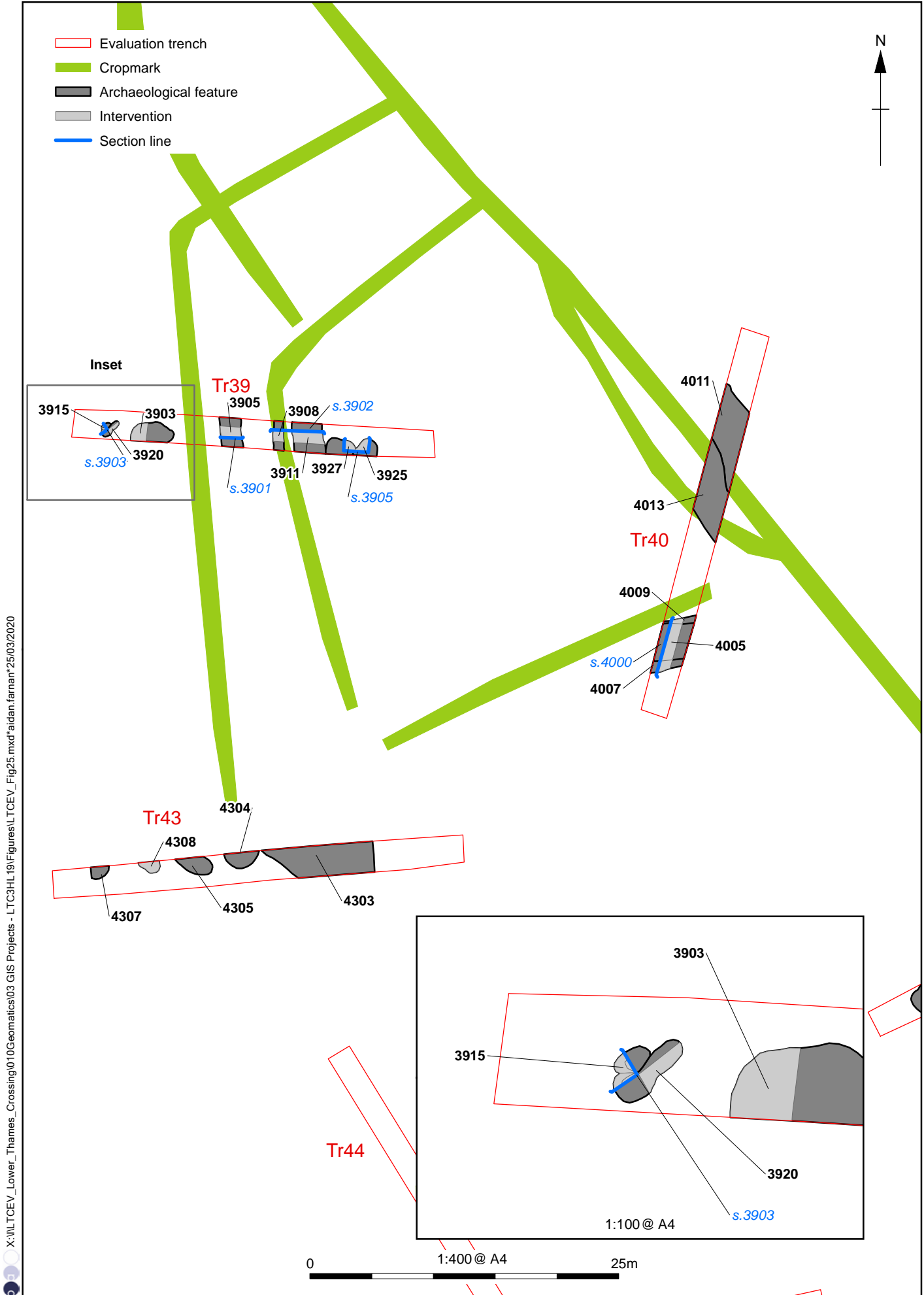

Figure 25: Plan of Trenches 39, 40 and 43

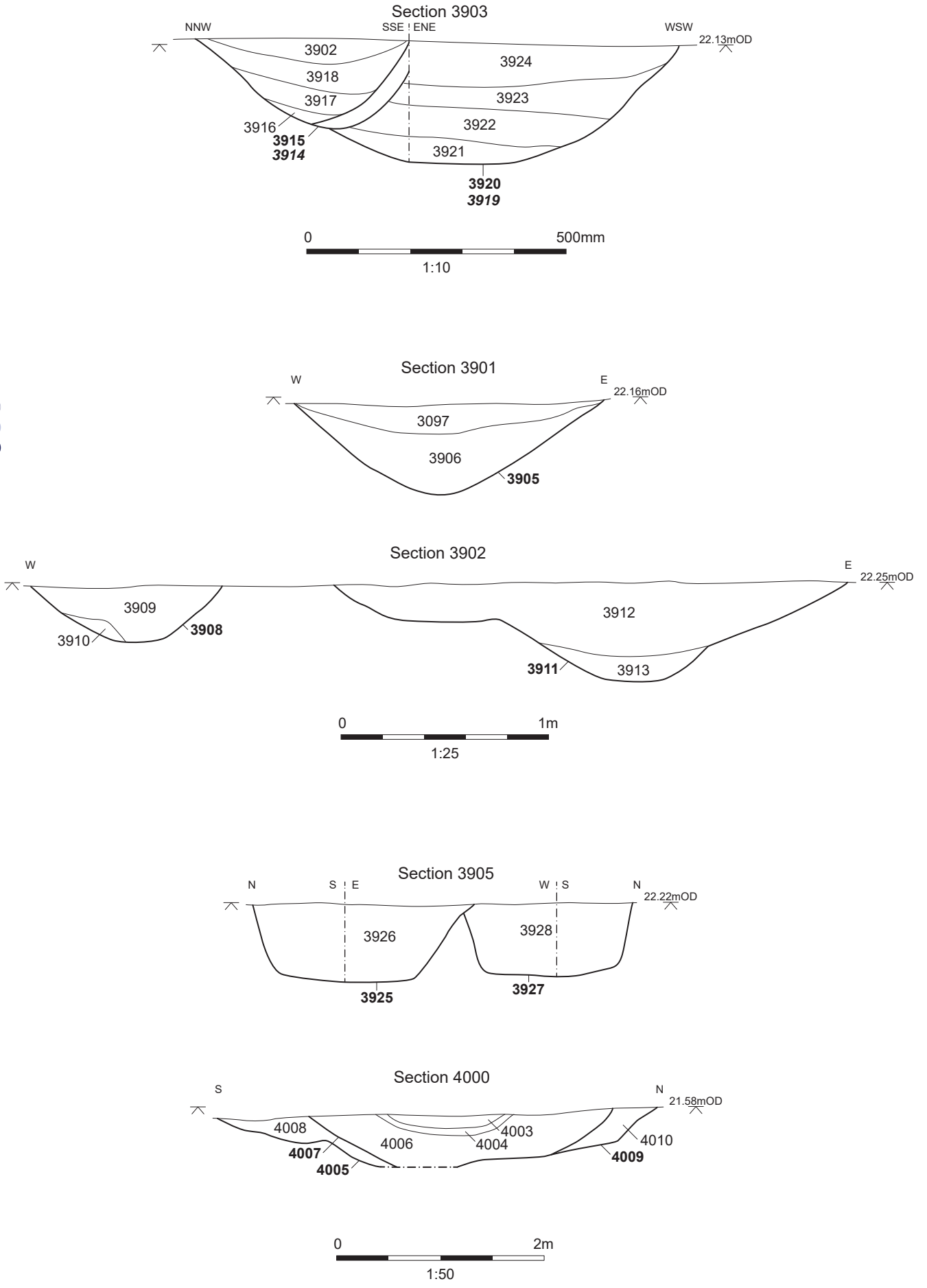

Figure 26: Sections (Trenches 39 and 40)

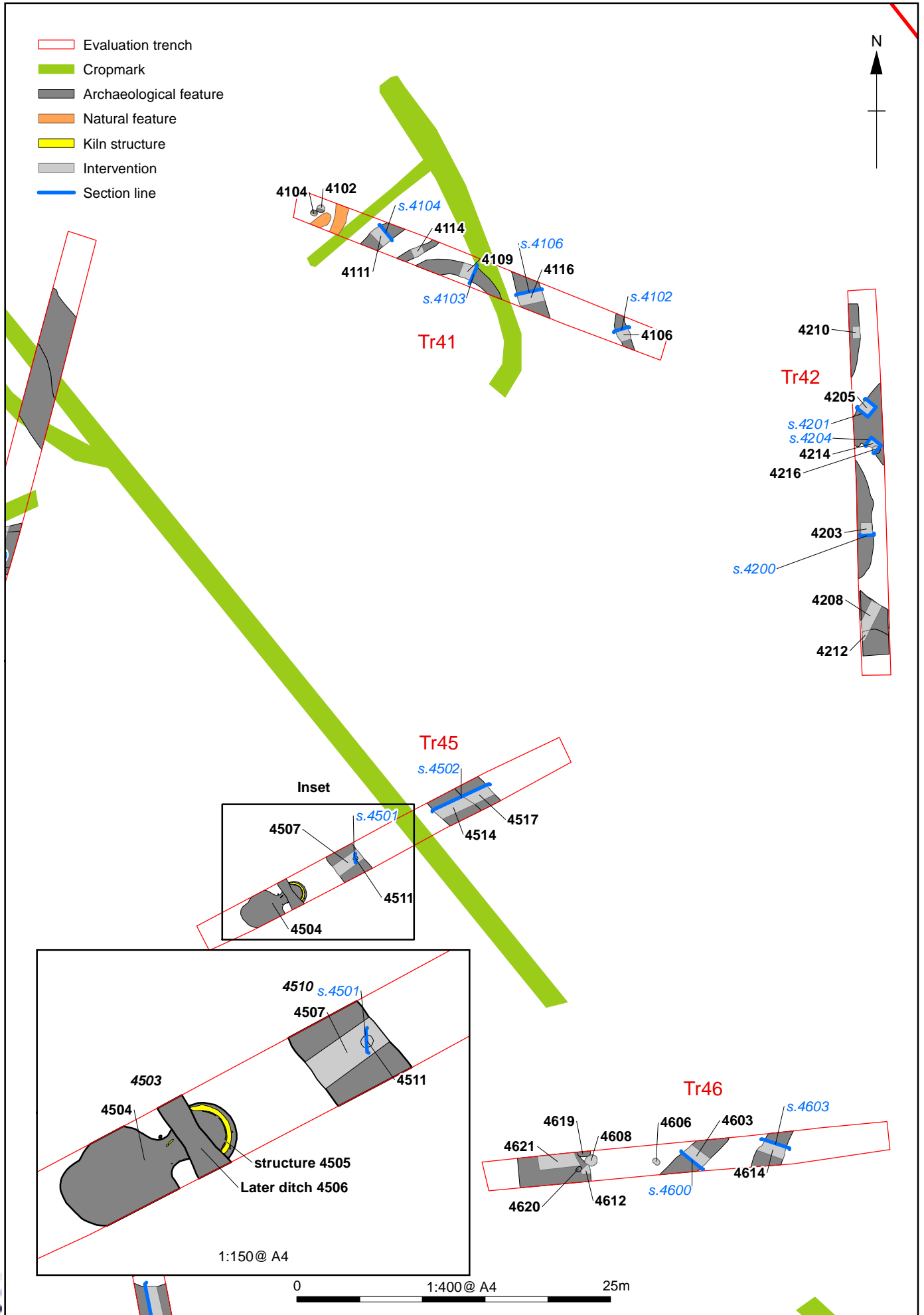

Figure 27: Plan of Trenches 41, 42, 45 and 46

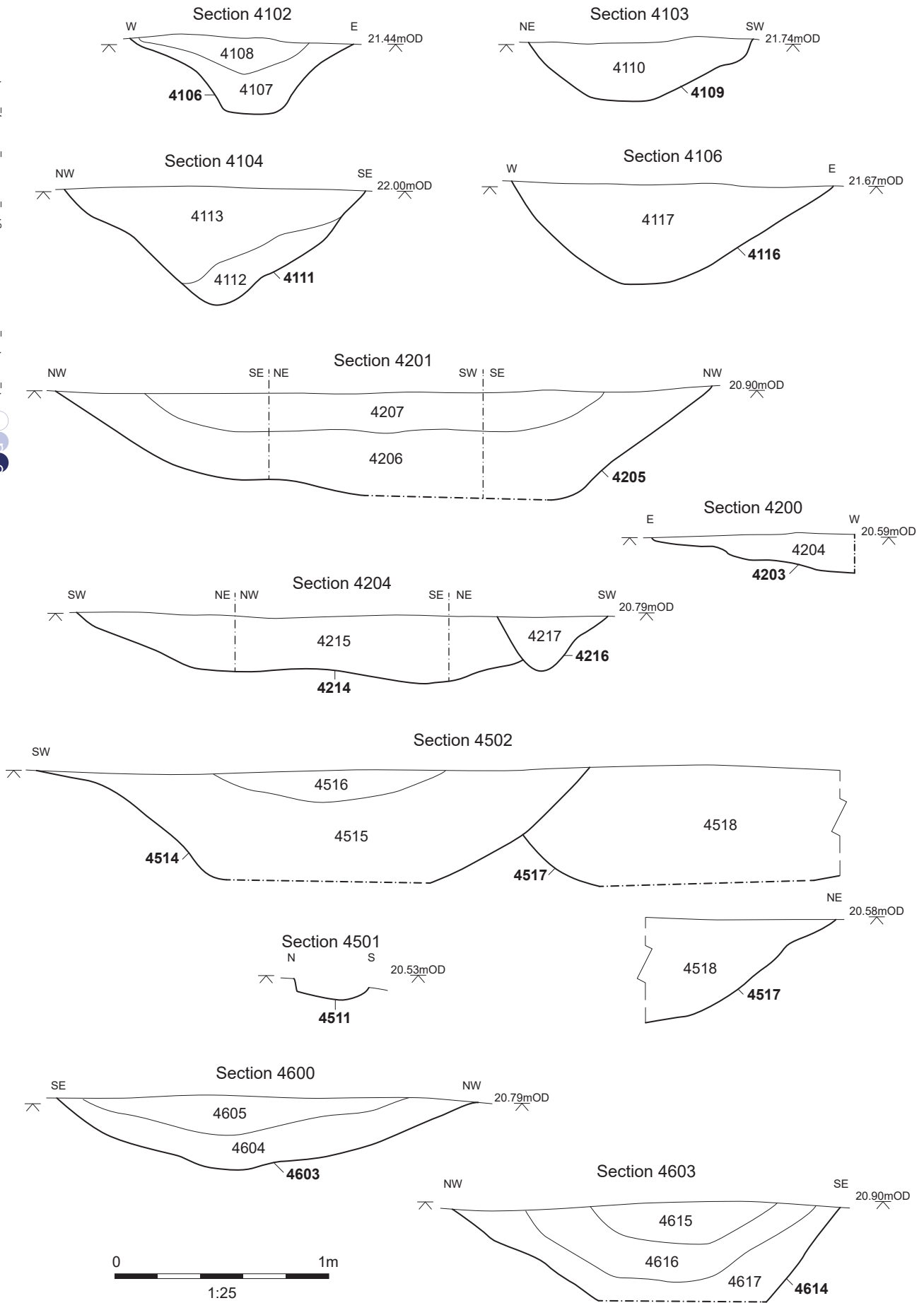

Figure 28: Sections (Trenches 41, 42, 45 and 46)

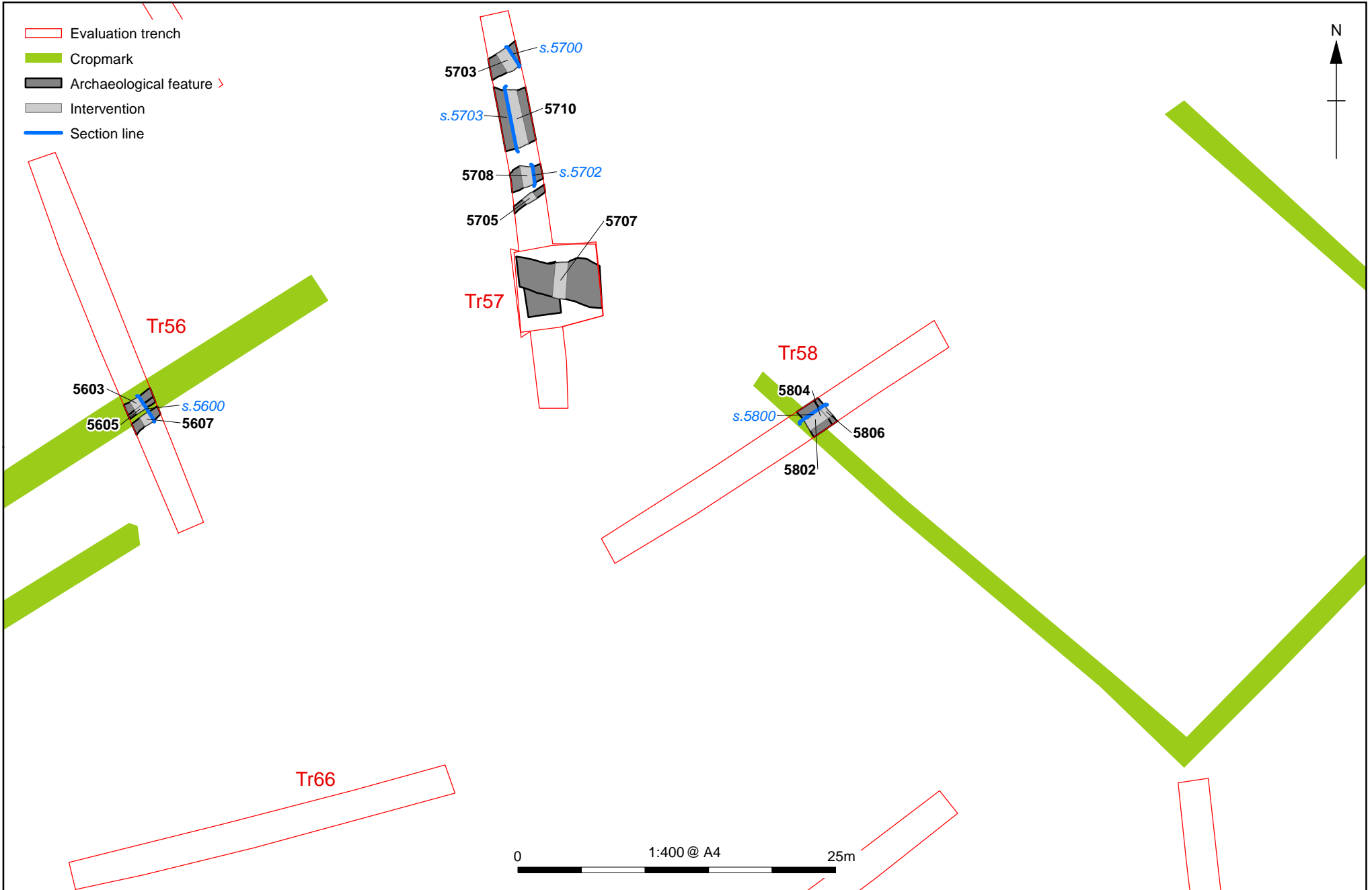

Figure 29: Plan of Trenches 56, 57 and 58

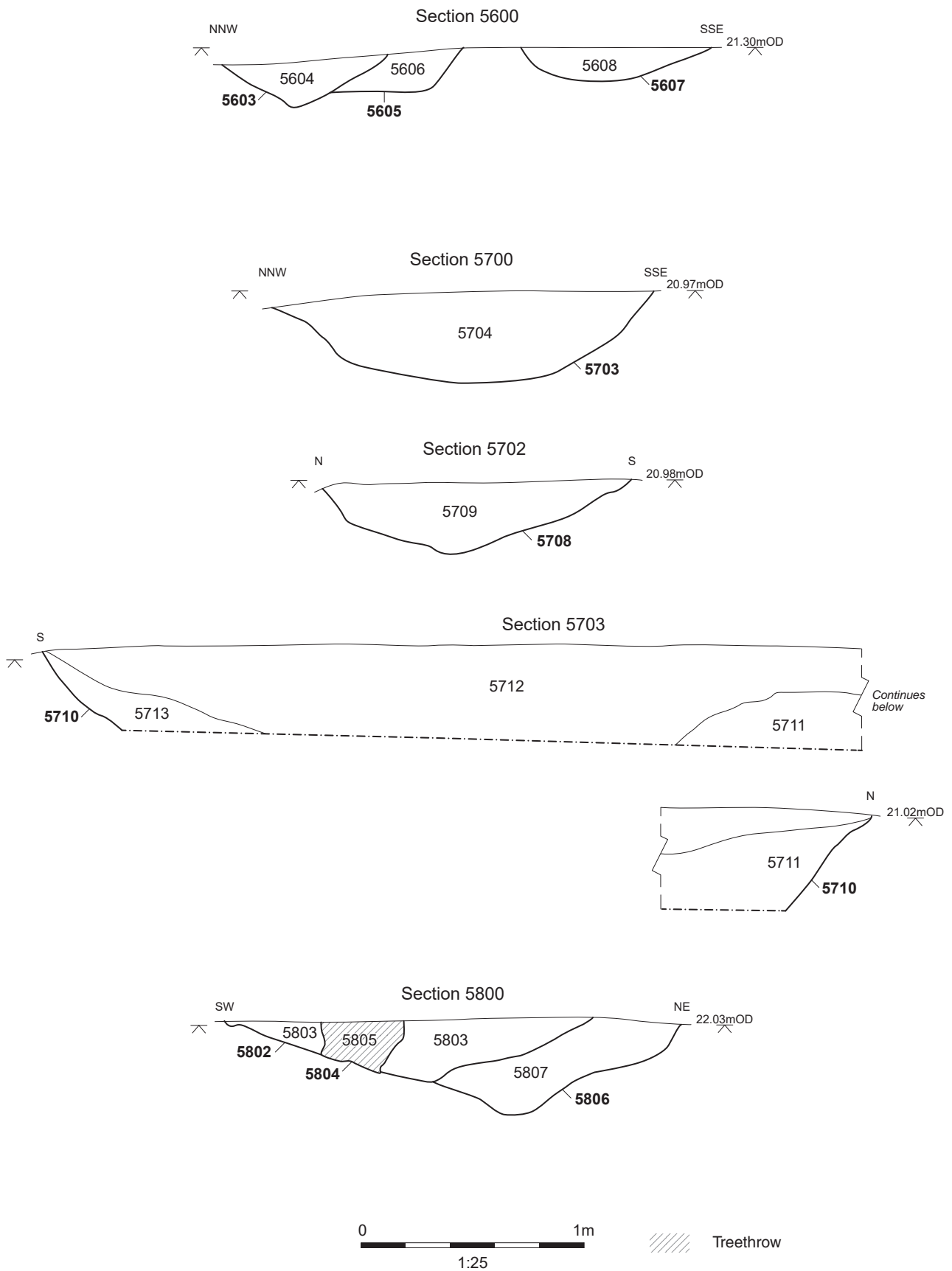

Figure 30: Sections (Trenches 56, 57 and 58)

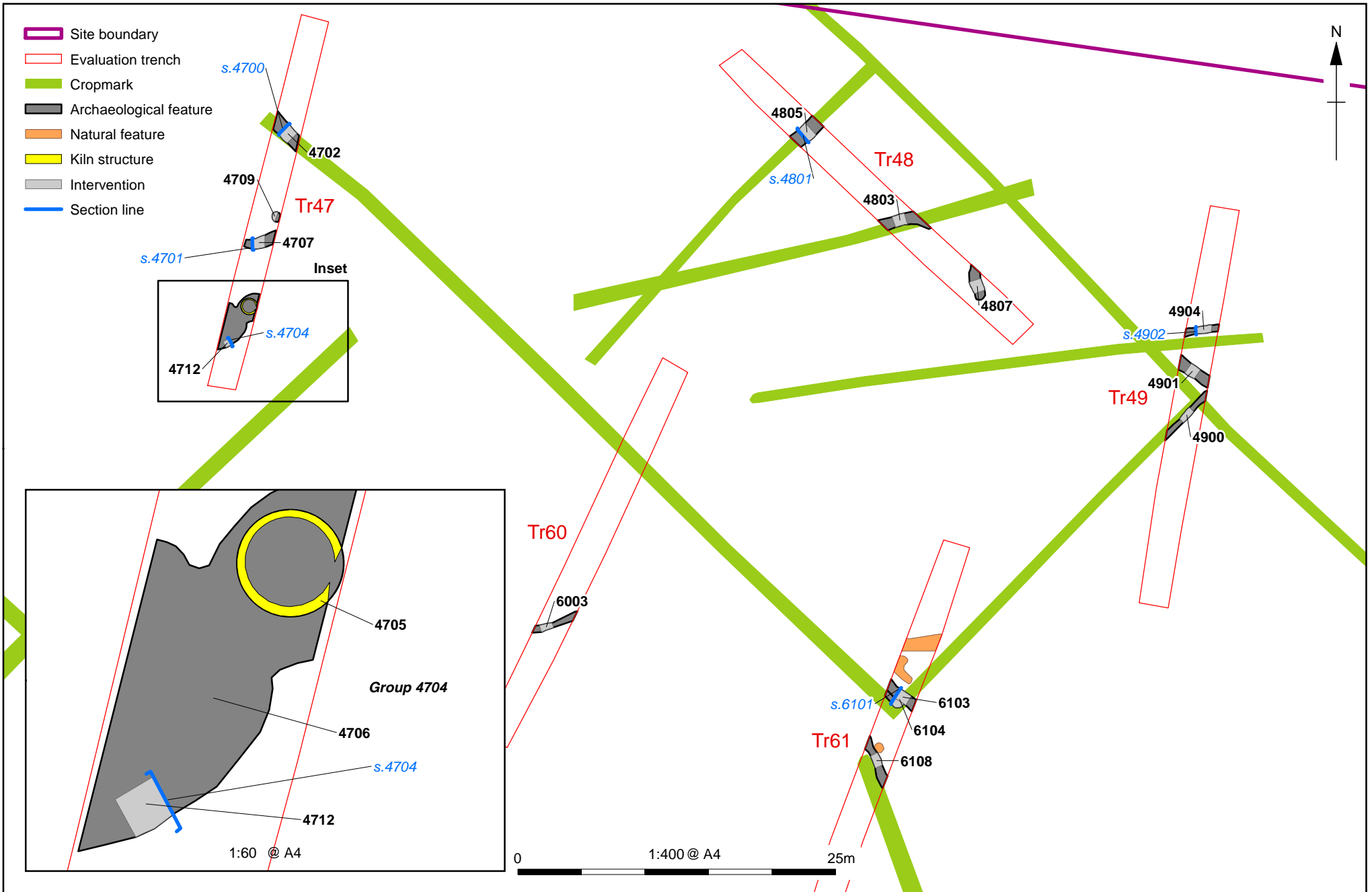

Figure 31: Plan of Trenches 47, 48, 49, 60 and 61

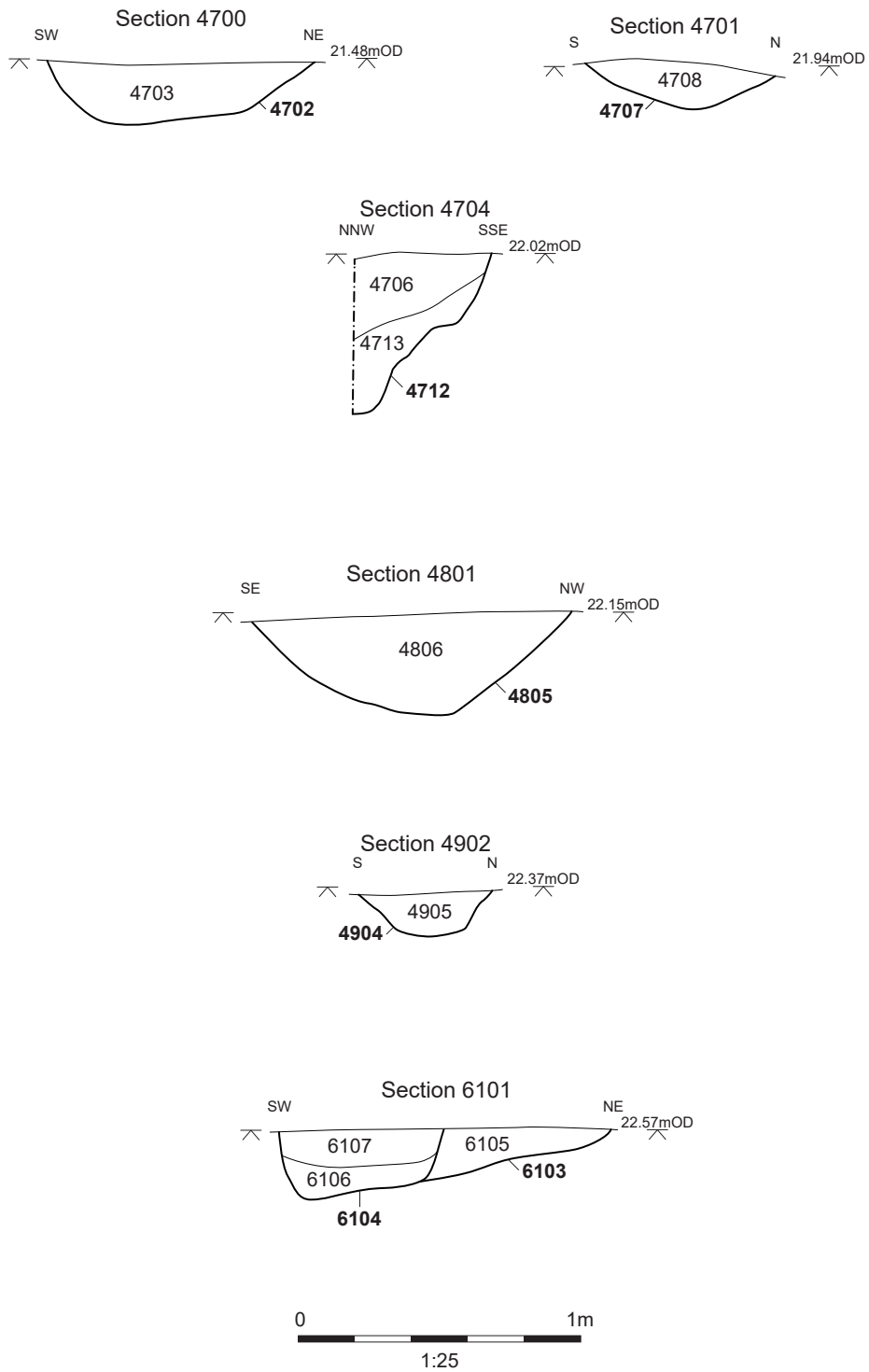

Figure 32: Sections (Trenches 47, 48, 49 and 61)



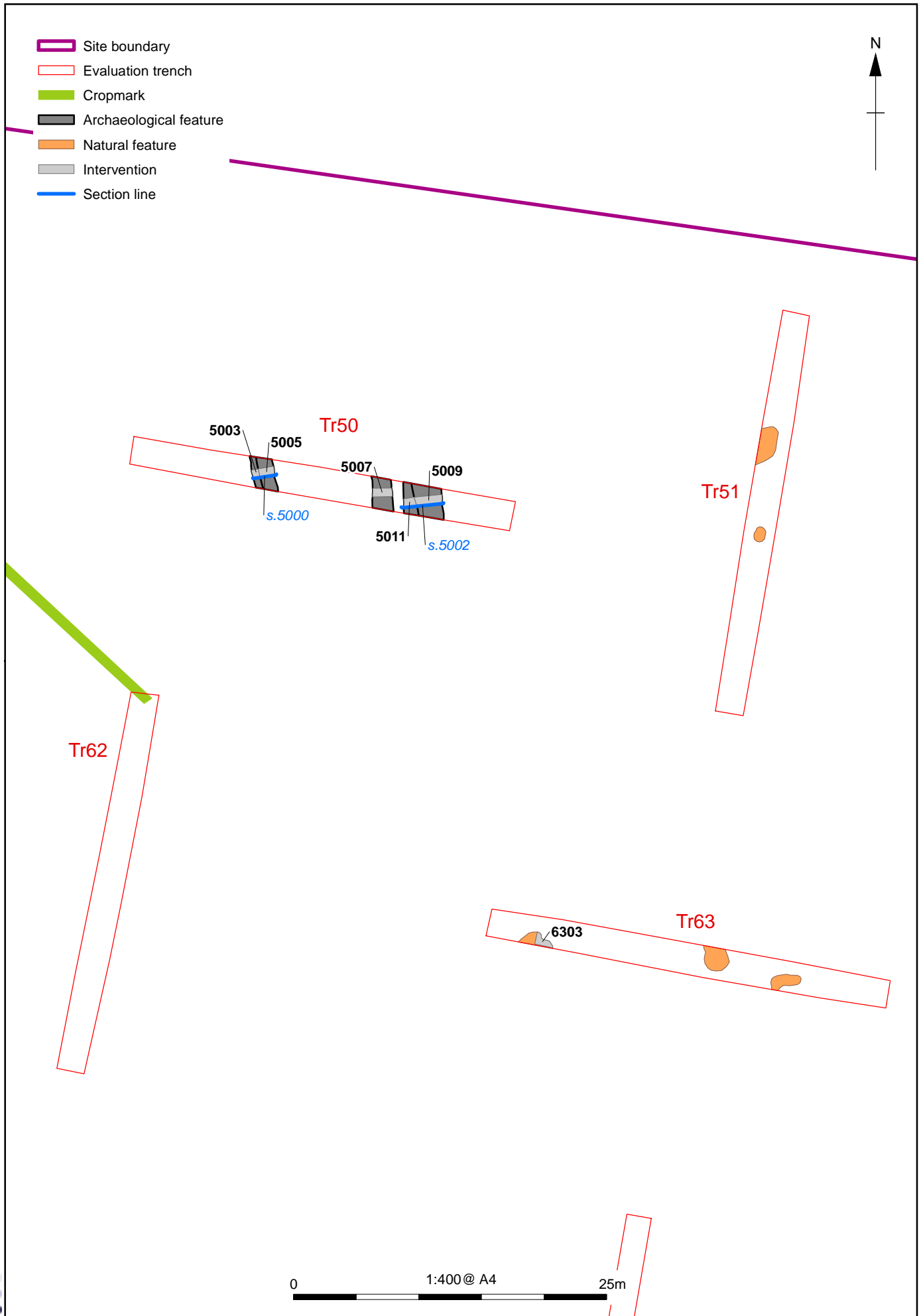

Figure 33: Plan of Trenches 50, 51, 62 and 63

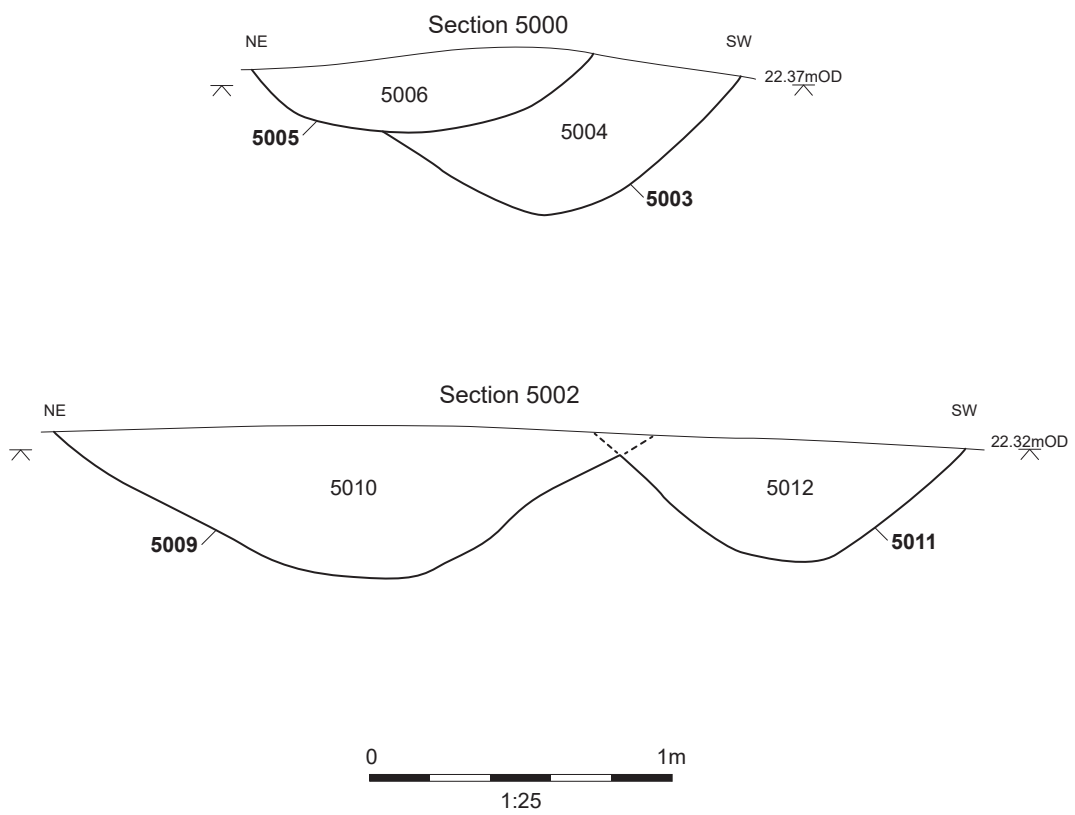

Figure 34: Sections (Trench 50)

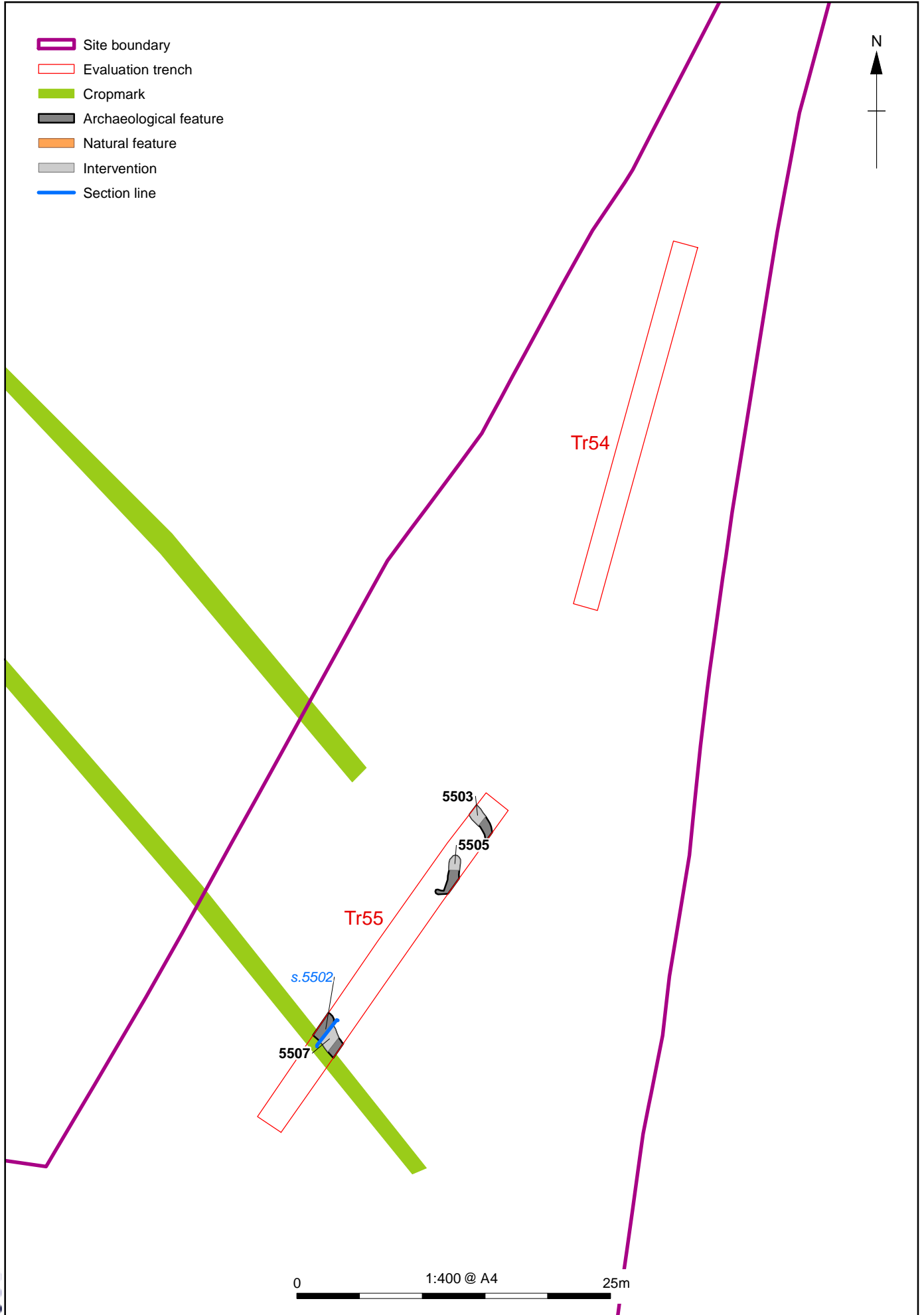

Figure 35: Plan of Trenches 54 and 55

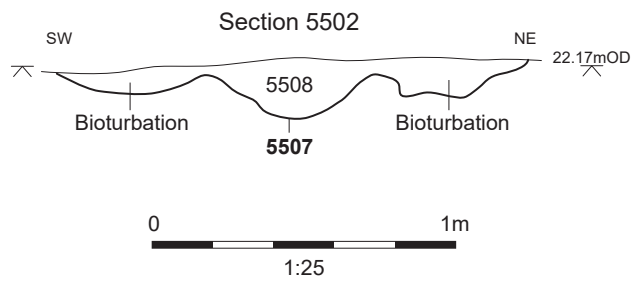

Figure 36: Section (Trench 55)

X:\MLTCEV\_Lower\_Thames\_Crossing\010Geomatics\03 GIS Projects - LTC3HL\19\Figures\LTC3EV\_Fig37.mxd\aidan.faman\25/03/2020

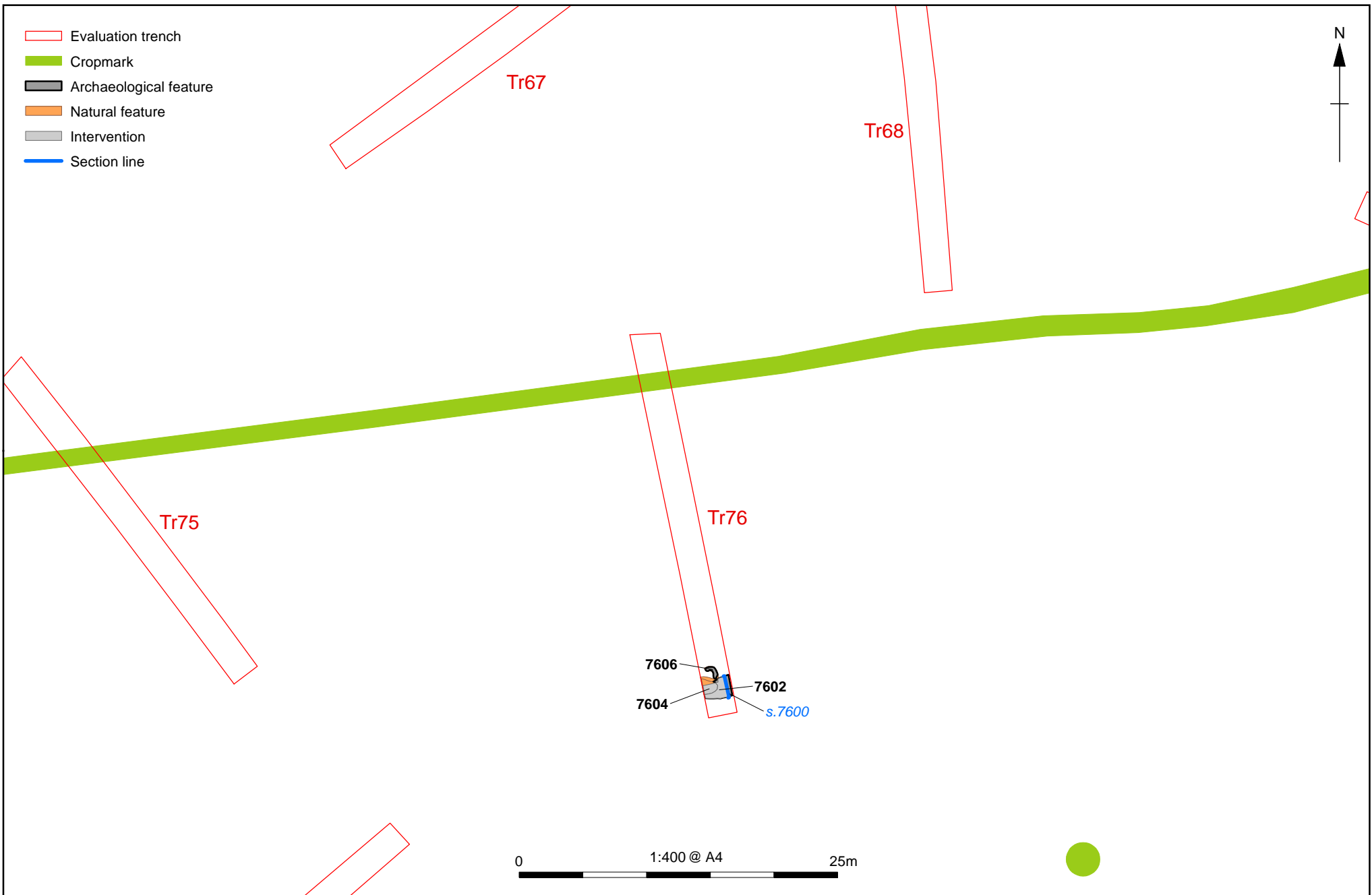

Figure 37: Plan of Trenches 75 and 76

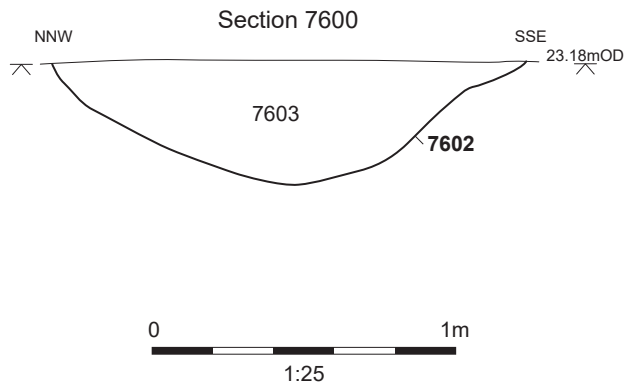

Figure 38: Section (Trench 76)

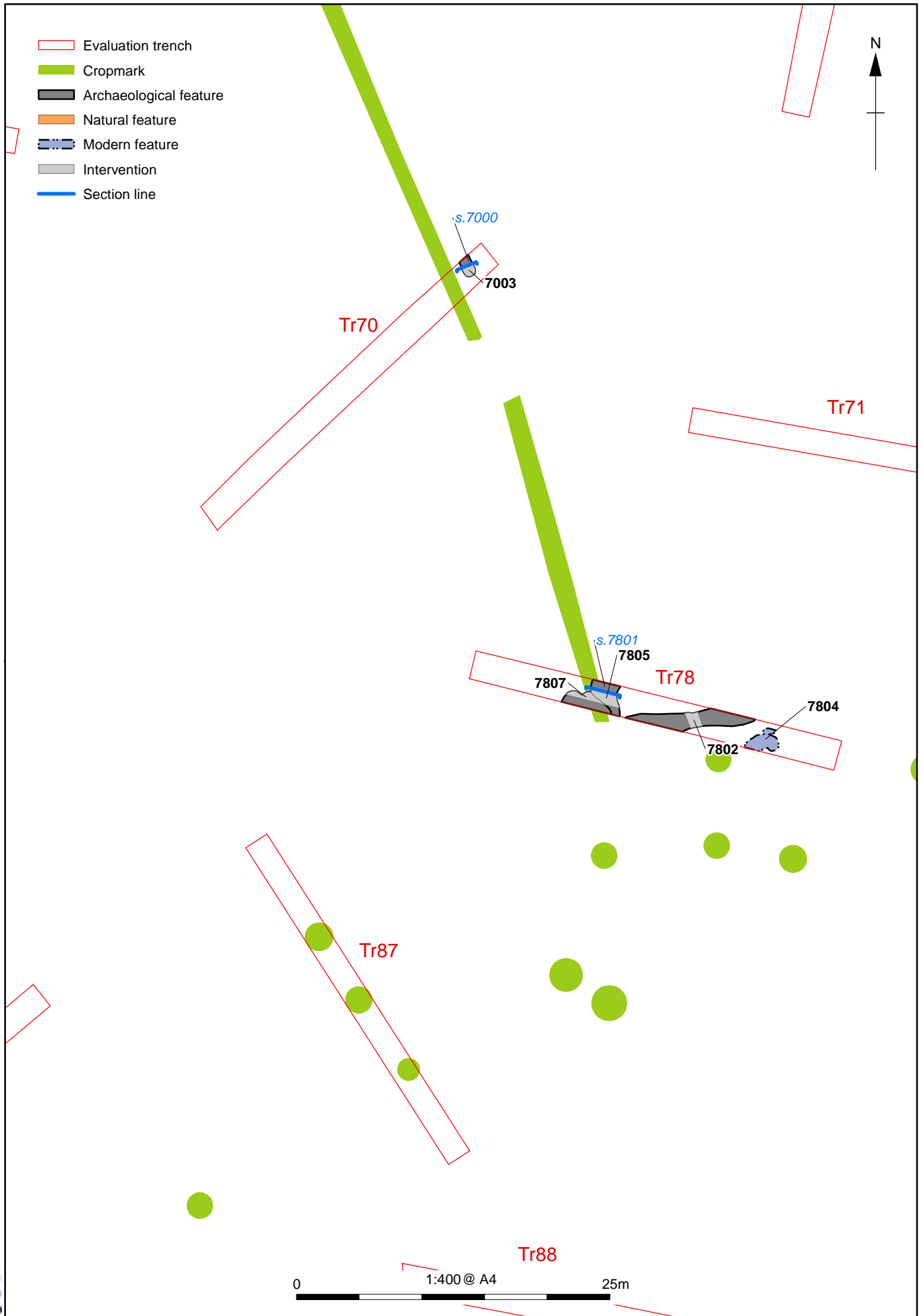

Figure 39: Plan of Trenches 70 and 78

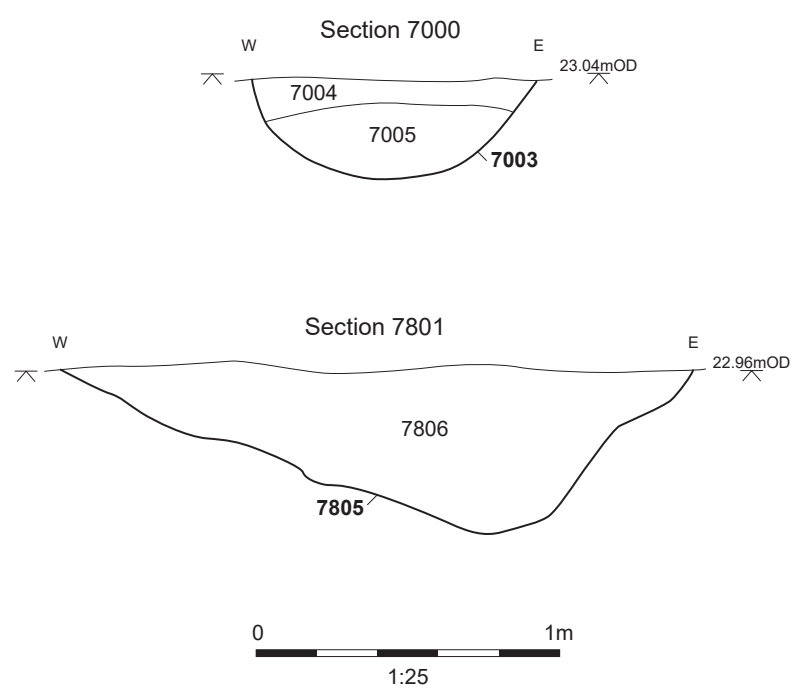

Figure 40: Sections (Trenches 70 and 78)



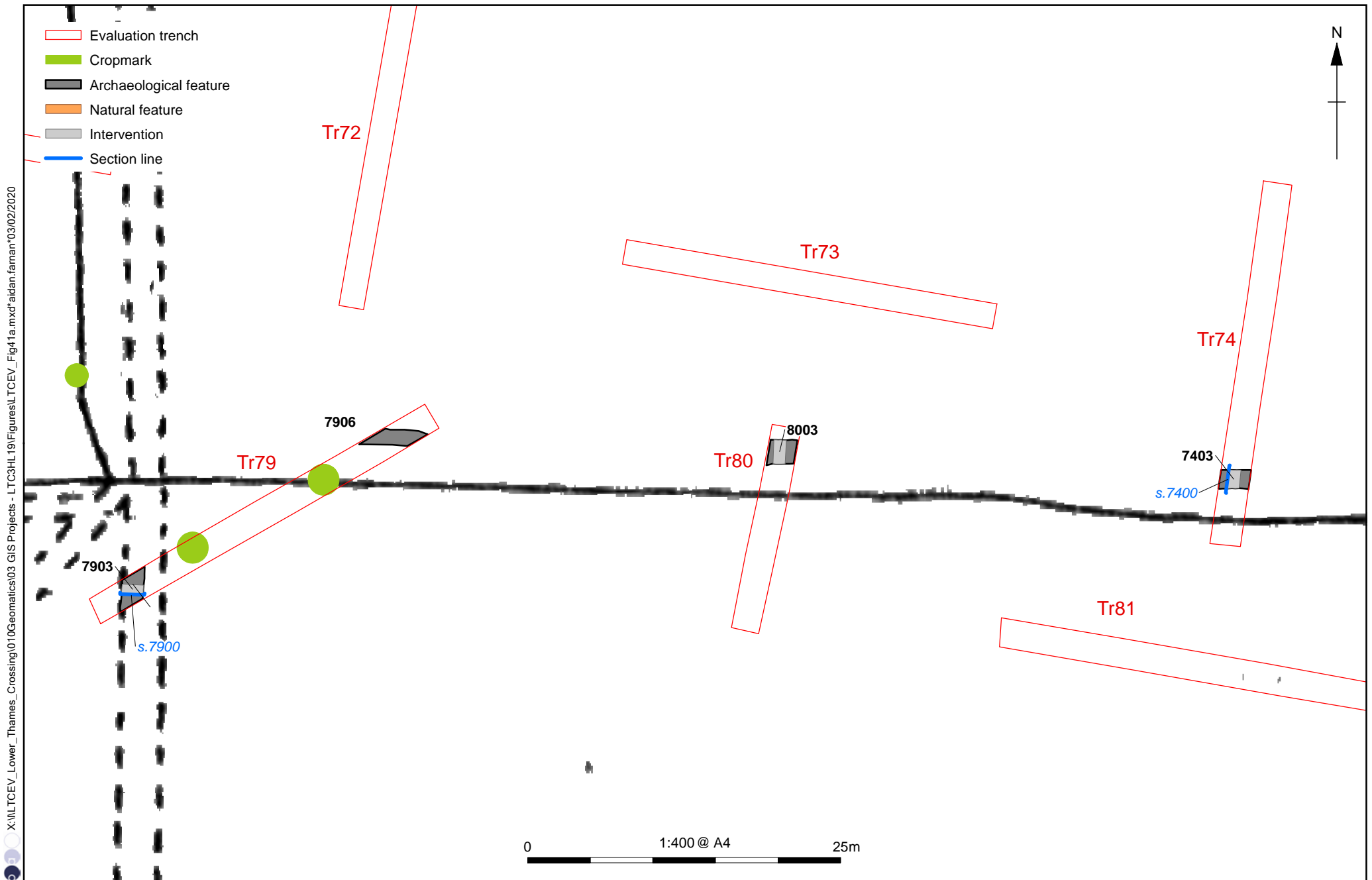

Figure 41: Plan of Trench 74, 79 and 80, overlain on the OS 1st Edition map 1897

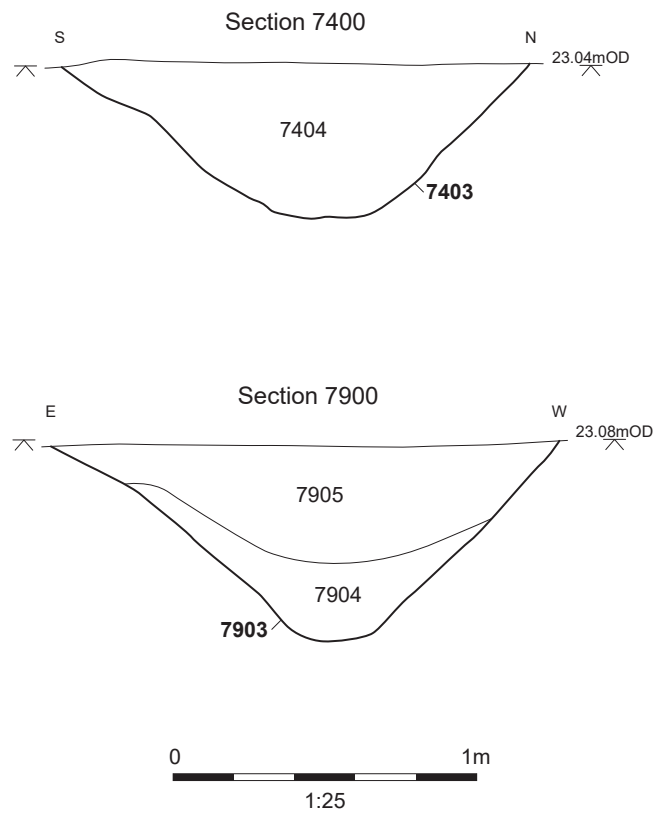

Figure 42: Sections (Trenches 74 and 79)

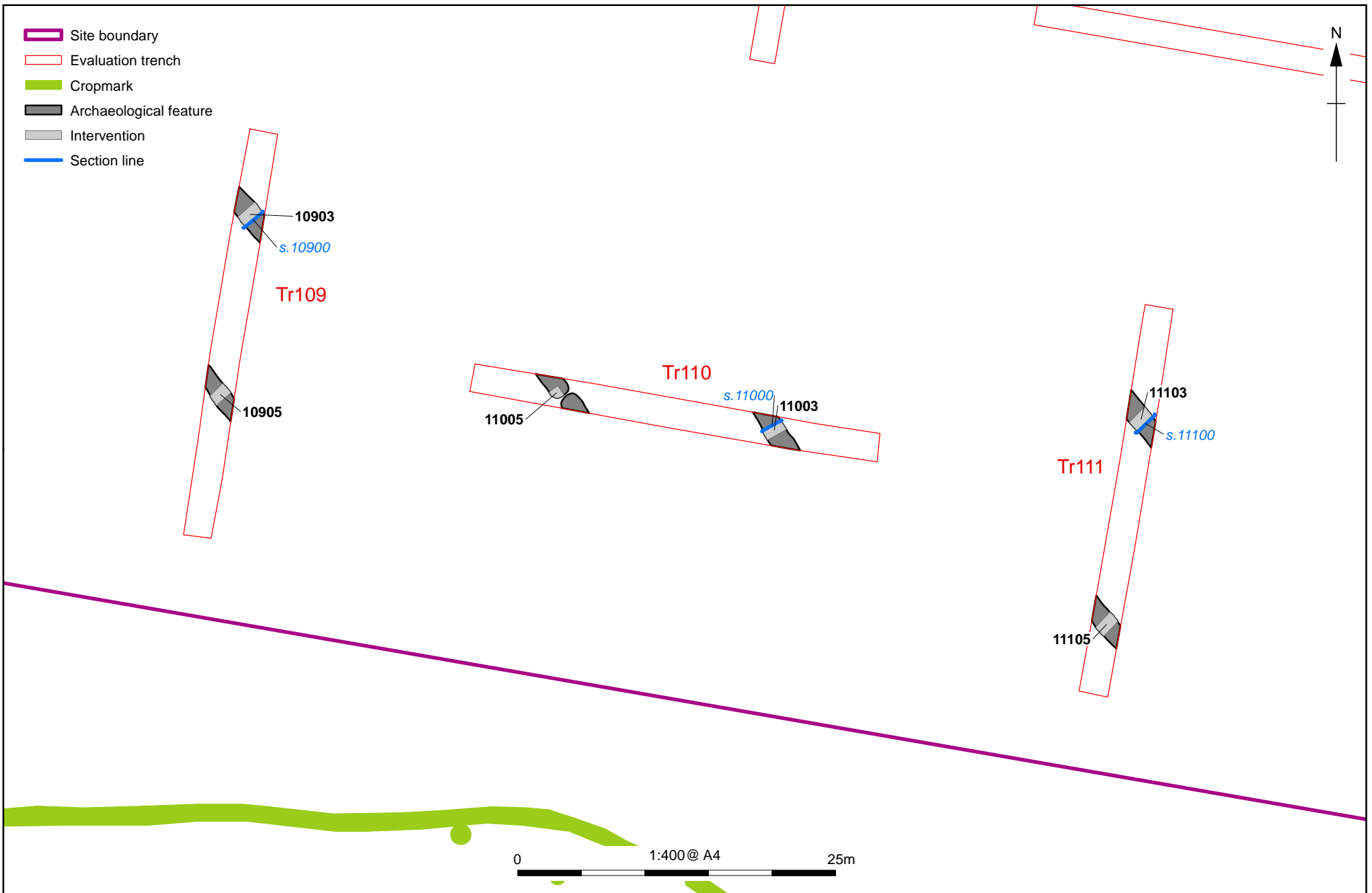

Figure 43: Plan of Trenches 109, 110 and 111

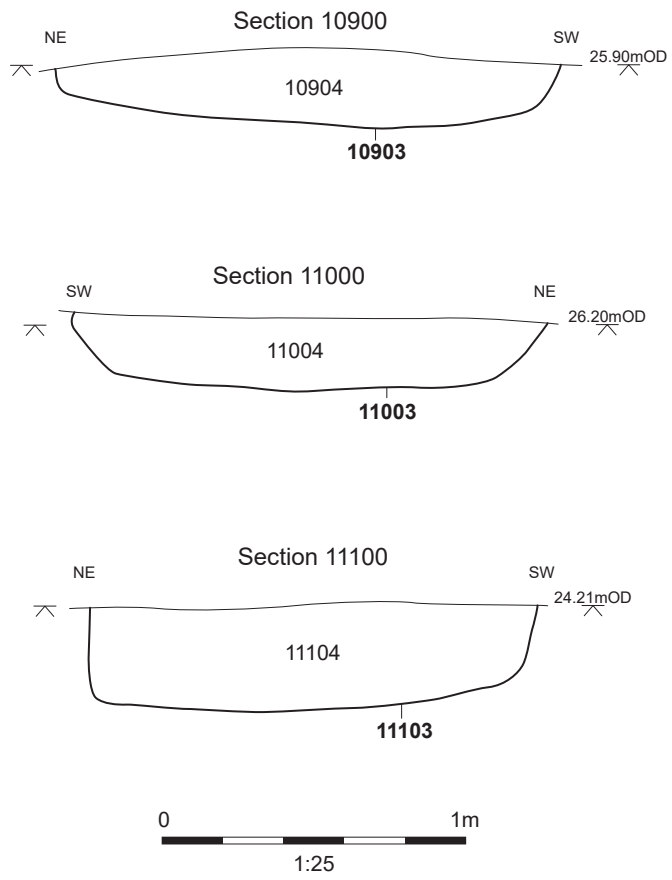

Figure 44: Sections (Trenches 109, 110 and 111)

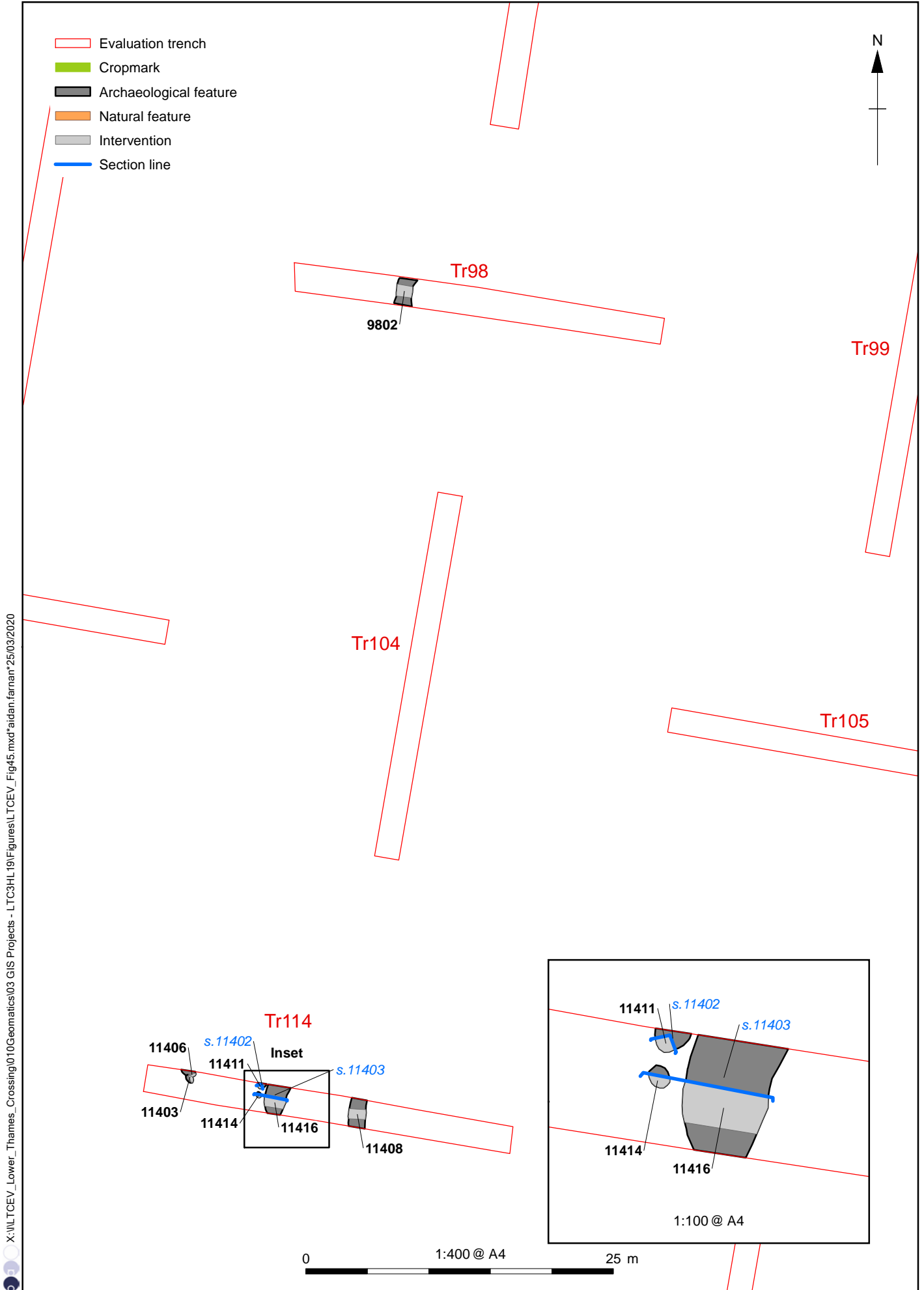

Figure 45: Plan of Trenches 98 and 114

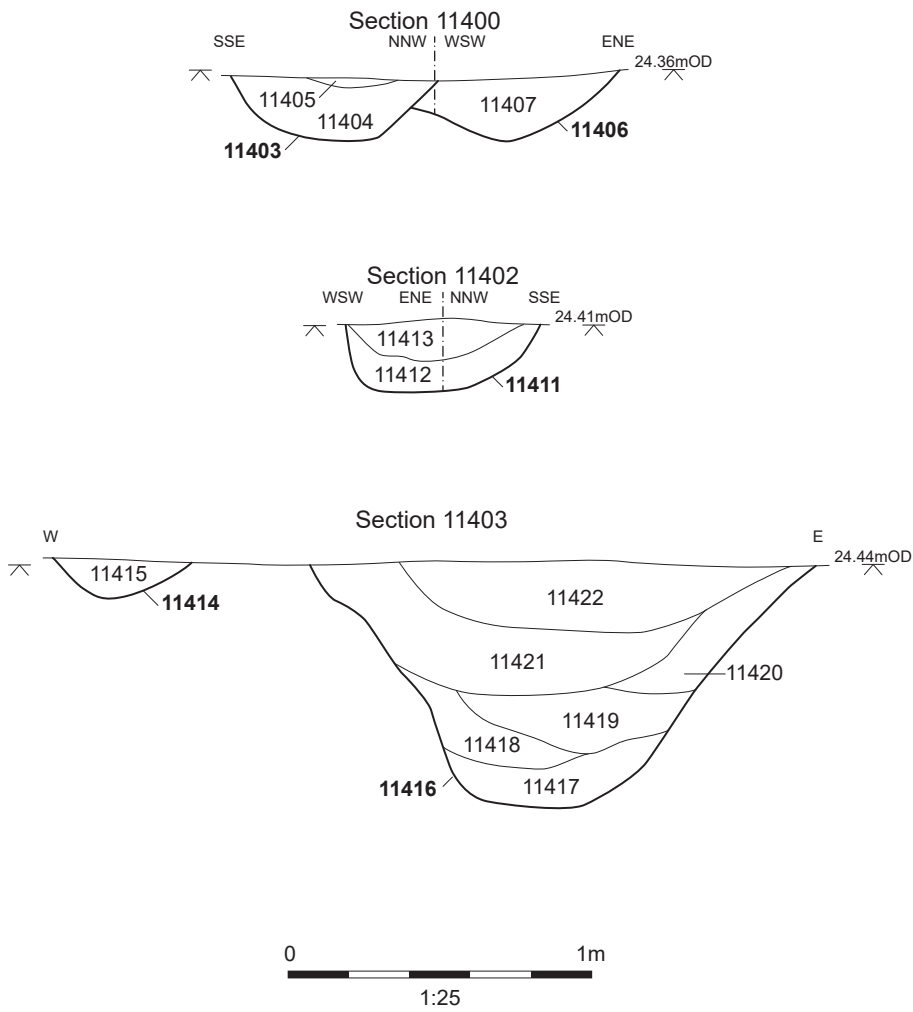

Figure 46: Sections (Trench 114)



Plate 1: Ditch 1103 facing south-east



Plate 2: Cremation pit 1509 with grave goods



Plate 3: Ditch 1513 facing north-west



Plate 4: Ditch 1803 facing north-west





Plate 5: Pit 3303 facing north-east



Plate 6: Oven pit 3914 facing south-east



Plate 7: Section 4201 of large pit 4205 facing north-east



Plate 8: Kiln 4503 facing south-west



Plate 9: Ditches 4517 and 4514 facing north-west



Plate 10: Pit 4606 facing south-west



Plate 11: Pit 4608 facing north-west



Plate 12: Pit 4709 facing east



Plate 13: Kiln 4704 facing north-east



Plate 14: Ditch 7003 facing north



Plate 15: Ditch 7805 facing north



Plate 16: Ditch 7903 facing south

**COVER SHEET**

<b>Title:</b>	<b>Archaeological Evaluation Report for Trial Trenching of Land Parcel 4 Old House, Chadwell St Mary, Essex</b>
<b>Project Name:</b>	<b>Lower Thames Crossing Enabling Works</b>
<b>Ref No:</b>	<b>HE540039-BAL-GEN-GEN-REP-HER-00023</b>
<b>Revision No:</b>	<b>PO1</b>
<b>Review Date:</b>	<b>27<sup>th</sup> March 2020</b>
<b>Status:</b>	<b>S3</b>
<b>No. of Pages</b>	<b>130</b>

<b>Rev</b>	<b>Date of Issue</b>	<b>Revision Status</b>	<b>Originator</b>	<b>Checker</b>	<b>Approver</b>
PO1	21.01.2020	S3 For Review and Comment	Jack Kilburn	Paulo Pinho	George Pargeter



# Lower Thames Crossing

Archaeological Evaluation Report for Trial Trenching of  
Land Parcel 4  
Old House, Chadwell St Mary, Essex

Document Number: HE540039-BAL-GEN-GEN-REP-HER-00023

**March 2020**





Revision	Production Date	Prepared by	Checked by	Approved for release by	Sections revised
1.1	26 February 2020	Anna Moosbauer Cotswold Archaeology	Edward Biddulph Oxford Archaeology		
1.2	30th March 2020		Steve Lawrence Oxford Archaeology		

This Evaluation Report has been prepared for Highways England in accordance with the terms and conditions of appointment stated in the Lower Thames Crossing (LTC) Technical Partner Contract. LTC cannot accept any responsibility for any use of or reliance on the contents of this document by any third party.

# Contents

---

Section	Page
<b>Summary</b> .....	<b>7</b>
<b>Acknowledgements</b> .....	<b>8</b>
<b>1 Introduction</b> .....	<b>9</b>
1.1 Project details and scope of work .....	9
1.2 Location, topography and geology .....	10
1.3 Previous investigations .....	10
1.4 Archaeological and historical background.....	11
<b>2 Project Aims</b> .....	<b>14</b>
2.1 General aims .....	14
2.2 Specific objectives .....	15
<b>3 Methodology</b> .....	<b>17</b>
3.1 Constraints.....	17
3.2 Methodology for the evaluation .....	17
<b>4 Results</b> .....	<b>18</b>
4.1 Introduction and presentation of results .....	18
4.2 General soils and ground conditions.....	18
4.3 General distribution of archaeological deposits .....	19
4.4 Trench 11.....	19
4.5 Trench 15.....	19
4.6 Trench 17.....	19
4.7 Trench 19.....	19
4.8 Trenches 22, 23 and 24 .....	20
4.9 Trench 25.....	20
4.10 Trench 36.....	20
4.11 Trench 37.....	20
4.12 Trench 39.....	21
4.13 Trench 47.....	21
4.14 Trench 49.....	21
4.15 Trench 51.....	21
4.16 Trench 52.....	22
4.17 Trench 58.....	22
4.18 Trench 62.....	22
4.19 Trenches 61 and 63 .....	23
4.20 Trench 72.....	23
4.21 Trench 73.....	23
4.22 Trench 80.....	23
4.23 Trench 83.....	23
4.24 Trench 96.....	24
4.25 Trench 97.....	24
4.26 Trench 99.....	24
4.27 Trench 111.....	24
4.28 Trench 112.....	24
4.29 Trenches 54, 76 and 113 .....	24

4.30	Trench 114.....	25
4.31	Trench 115.....	25
4.32	Trench 117.....	25
4.33	Trench 118.....	25
4.34	Trench 119.....	26
4.35	Trench 120.....	26
4.36	Trench 121.....	26
4.37	Trench 122.....	27
4.38	Trench 124.....	27
4.39	Trench 125.....	27
4.40	Trench 130.....	27
4.41	Trench 138.....	27
4.42	Trench 139.....	28
4.43	Finds summary .....	28
4.44	Environmental summary .....	29
<b>5</b>	<b>Discussion .....</b>	<b>30</b>
5.1	Reliability of field investigation .....	30
5.2	Interpretation.....	30
5.3	Evaluation objectives and results.....	31
<b>Appendix A</b>	<b>Trench Tables .....</b>	<b>33</b>
<b>Appendix B</b>	<b>Finds Reports .....</b>	<b>82</b>
<b>Appendix C</b>	<b>Environmental Reports .....</b>	<b>96</b>
<b>Appendix D</b>	<b>References .....</b>	<b>101</b>
<b>Appendix E</b>	<b>Abbreviations and Glossary .....</b>	<b>103</b>
<b>Appendix F</b>	<b>Site Summary.....</b>	<b>104</b>

## Figures

Figure 1 – Site location

Figure 2 – Plan of trench layouts, cropmark features and archaeological features

Figure 3 – Plan of Trench 19

Figure 4 – Plan of Trench 22, 23 and 24

Figure 5 – Plan of Trench 25

Figure 6 – Plan of Trench 47

Figure 7 – Plan of Trench 51

Figure 8 – Plan of Trenches 61 and 62

Figure 9 – Plan of Trench 63

Figure 10 – Plan of Trench 80

Figure 11 – Plan of Trenches 54, 76 and 113

Figure 12 – Plan of Trench 115

Figure 13 – Plan of Trench 118

Figure 14 – Plan of Trenches 120, 121 and 122

Figure 15 – Plan of Trench 124

Figure 16 – Plan of Trench 130

Figure 17 – Plan of Trench 138

Figure 18 – Plan of Trench 139

Figure 19 – Sections (Trenches 19, 23, 25, 51 and 62)

Figure 20 – Sections (Trenches 99, 113, 115, 121 and 122)

## Plates

Plate 1 - Ditch 2305 facing north-west

Plate 2 - In-situ heat affected soil in pit 3606 facing south-west

Plate 3 - Plan view of flint scatter in pit 5103 facing south

Plate 4 - Pit 5105 facing east

Plate 5 - Pit 9906 facing south-west

Plate 6 - Pit 11503 facing west

Plate 7 - Ditch 12202 facing east

## Tables

Table 1 - Summary of the prehistoric pottery

Table 2 – Summary and quantification of the pottery by context (Key: EVE estimated vessel equivalent; MV minimum number of vessels)

Table 3 – Record of fired clay assemblage

Table 4 – Description of CBM by context

Table 5 – Description of metal objects by context

Table 6 - Summary and quantification of the flint by type

Table 7 - The flint assemblage by context type

Table 8 - Assessment of CPR flots

## Summary

---

Oxford Cotswold Archaeology was commissioned by Balfour Beatty to undertake a trial trench evaluation of Land Parcel 4 of the Lower Thames Crossing Pre-Enabling Works. Land Parcel 4, also known as Old House, is located directly north of the suburbs of Chadwell St Mary within the county of Essex and Thurrock unitary authority (NGR TQ 64996 80073). The evaluation comprised 139 trenches and was completed between the 13th and the 30th January 2020.

The majority of the trenches towards the northern edge of the site revealed deep slope deposits marking a roughly NW-SE aligned dry channel. This corresponds with a large linear trend visible on available LiDAR data, which maps a dry valley continuing further east into Land Parcel 5.

Small assemblages of Neolithic material were encountered in Trenches 19 and 51, comprising worked flint, pottery and hazelnut shells. These demonstrate activity over a wide-ranging area that is probably contemporary with the life span of the causewayed enclosure located to the north of the site boundary.

Trenches 24, 124 and 125 included Iron Age remains, although the evidence is relatively sparse and does not suggest any high-level activity within the site.

Evidence for Romano-British remains was confined to Trench 37 at the western edge of the evaluation area. This suggests that the focal point of activity during the Roman period lay further to the west, within the adjacent Land Parcel 3 (Hornsby Lane), where evidence for more complex industrial activity was encountered.

Several NNE-SSW and WNW-ESE-aligned ditches encountered in the western half of the site match the orientations of post-medieval field boundaries marked on 1st Edition Ordnance Survey mapping. In addition, two wall lines and associated features encountered in Trenches 138 and 139 are likely related to the demolished Seaborough Hall. A single pit in Trench 139 provides some evidence for a late medieval presence at Seaborough Hall.

## Acknowledgements

---

Oxford Cotswold Archaeology would like to thank the client, Balfour Beatty, for commissioning this project and managing the site safety and attendances. Thanks are also extended to the Historic Environment Consultants, Richard Havis and Katie Lee-Smith, of Place Services at Essex County Council, for monitoring and providing advice throughout the project.

The project was managed for Oxford Cotswold Archaeology by Steve Lawrence. The fieldwork was directed by Mark Dodd and Molly Day, who were supported by Jana Smirnova, Adam Moffat, Megan Lillington, BJ Ware, David Pinches, Ioannis Thanos, Dan Firth, Fanny Dubuc, Enrico Ravanetti, Majbritt Bengtson, Tara Schug, James Sinclair and Alice Crush. Site survey was undertaken by Caroline Souday and Rachel Alexander and digitising was carried out by Gary Jones, Benjamin Brown and Simon Batsman. Thanks are also extended to the teams of OA staff who cleaned and packaged the finds under the management of Leigh Allen and Geraldine Crann, processed the environmental remains under the management of Rebecca Nicholson, and prepared the archive under the management of Nicola Scott.

# 1 Introduction

---

## 1.1 Project details and scope of work

- 1.1.1 The Lower Thames Crossing Project is located between the A2 in Kent and the M25 in the London Borough of Havering. A new road will run underneath the River Thames through a tunnel and emerge on the northern side of the river at East Tilbury. From the North Portal the road will run to the M25 at Junction 29 via the A13 and pass between North and South Ockendon. The development of the project is managed by LTC, a partnership between Highways England and a consultancy joint venture set up to oversee the scheme.
- 1.1.2 A programme of archaeological trial trenching began in the Essex part of the scheme in November 2019. A scheme-wide specification for trial trenching was written by LTC (Highways England 2018), and in July 2019 LTC commissioned Balfour Beatty to deliver the pre-Enabling Works. Balfour Beatty appointed Oxford Archaeology (hereafter OA) to prepare a project-wide written scheme of investigation (WSI) for the scheme, which (at the request of the key archaeological stakeholders) is divided into two parts, one for the Kent section, the other for Essex and Havering (Oxford Archaeology 2019a, 2019b).
- 1.1.3 Following completion of the project-wide WSIs, OA was also instructed to prepare a series of site-specific or group-site specific WSIs for approval by the key archaeological stakeholders in advance of trial trenching to inform the Development Consent Order (DCO). A detailed WSI was created for Land Parcel 4 prior to the trial trenching (Oxford Archaeology 2019c). The document also indicated the archaeological aims and objectives appropriate to the investigation of this land parcel by trenching and set out the methodology. This WSI was approved by Richard Havis, Principal Historic Environment Consultant for Place Services, Essex County Council (ECC), prior to the start of the fieldwork. Oxford Cotswold Archaeology was commissioned as Balfour Beatty's archaeological contractor to undertake the evaluation in accordance with the approved WSI and local and national planning policies.
- 1.1.4 The fieldwork was completed between the 13th and the 30th January 2020. All work followed the MoRPHE Project Manager's guide (Historic England 2015), and the Code of Conduct of the Chartered Institute for Archaeologists (CIfA). The archaeological works also adhered to the standards and guidance for archaeological evaluation, excavation and archiving (CIfA 2014a; CIFA 2014b).
- 1.1.5 The fieldwork was monitored by Richard Havis and Katie Lee-Smith, Place Services, ECC, advising the Borough of Thurrock.



## 1.2 Location, topography and geology

- 1.2.1 Land Parcel 4 is located directly north of the suburbs of Chadwell St Mary, 0.7km south of the A13 (Fig. 1), within the county of Essex and Thurrock unitary authority (NGR TQ 64996 80073). The land parcel, comprising two arable fields, is roughly rectangular and has two projecting sections on the north edge, covering a total area of 21.47ha. The site is bounded to the west by a public footpath and hedgerow, to the south by a public footpath and a residential area, and to the east by Brentwood Road, while the northern boundary bisects an open arable field.
- 1.2.2 The bedrock geology of Land Parcel 4 is variable, with sands of the Thanet Formation to the south and Lambeth Group gravels within the northern part. The superficial geology of the land parcel is also varied, with most of the land parcel underlain by sand and gravels of the Boyn Hill Gravel Member. In addition, the northern edge of the site is comprised of Head deposits of clay, silt, sand and gravel. These hill-wash deposits were formed by fine grained materials collecting at the base of a slope (BGS 2020).
- 1.2.3 The land parcel is currently in use as arable agricultural land. The surrounding 1km is a mixture of agricultural land and urban development associated with Orsett Heath to the south-west and Chadwell St Mary to the south. Further afield to the north-west the A13 and the A1089 bisects the landscape displacing the historical field boundaries in this area.
- 1.2.4 Land Parcel 4 is situated across the western end of a dry valley which runs east across the gravel terrace to the south of Orsett. The land parcel itself contains areas of higher ground towards the southern edge at c 24-25m above Ordnance Datum (aOD); to the north-west, where the elevation is similar; and in the north-east corner, where ground levels rise to over 35m aOD. The base of the dry valley crosses the northern part of the land parcel, with the lowest point at c 20m aOD. Consequently, a gradual slope downwards from the south edge of the field is perceptible on site, and a somewhat steeper slope rising towards the north-east corner. Within the dry valley, slope deposits and colluvial layers of Head have accumulated. No permanent streams are marked in the immediate vicinity of the land parcel, but a drainage ditch is located 280m to the east, which may represent the remnants of a stream which joined another further down the valley at Linford (1.3km to the south-east).

## 1.3 Previous investigations

- 1.3.1 No known below-ground archaeological investigation has been undertaken previously within this land parcel.

## 1.4 Archaeological and historical background

- 1.4.1 The following chronological summary of known archaeology is taken from the detailed WSI for Land Parcel 4 (Oxford Archaeology 2019c). The site is situated on the terrace to the south of the Mar Dyke valley where Holocene prehistoric features, find spots and cropmarks have been identified. The cropmarks that have been recorded within the site are those mapped by the 'Aerial Investigation and Mapping Report' (Place Services 2019), shown in Figure 2.
- 1.4.2 **Palaeolithic.** A number of Palaeolithic artefact find spots, including four handaxes and a number of flakes, have been recorded c 0.4km to the west and c 0.8km to the south-west of the site.
- 1.4.3 **Mesolithic.** Mesolithic finds spots have been recorded 0.1-0.3km to the west and 0.7km to the south of the site.
- 1.4.4 **Neolithic.** A scheduled early Neolithic causewayed enclosure is located on the northern boundary of the land parcel. When this was excavated in 1975, the pottery found within the causewayed enclosure was of Mildenhall-type dating to the early Neolithic along with flints of the same date. The secondary ditch silts of the enclosure also contained a small quantity of late Neolithic/early Bronze Age pottery (Hedges and Buckley 1978, 219-308).
- 1.4.5 A possible east-west aligned mortuary enclosure is located 0.6km west of the land parcel. Mortuary enclosures are extremely rare and are usually located within a wider ceremonial landscape of other Neolithic features.
- 1.4.6 Neolithic flints including blades, scrapers, arrowheads, cores and hammer stones were recorded across several fields located c 100-300m south-west of the site.
- 1.4.7 **Bronze Age.** The cropmarks of two ring-ditches, one measuring c 20m and the other c 10m in diameter, are located within the eastern and south-eastern part of Land Parcel 4 (Place Services 2019, site 18). A further ring-ditch is also located c 50m south-east of and outside the site. The ring-ditch at the southern edge of the site and the one just beyond the land parcel boundary are both situated on the higher ridge of a dry valley. This setting is supports these being interpreted as the remains of Bronze Age barrows. The smaller ring-ditch within the site, around 120m further north, is located within the valley area and is perhaps more likely to be a roundhouse. Several possible circular pits are located around the possible roundhouse in the centre of Land Parcel 4 and may be associated with it.
- 1.4.8 The Essex HER records that four bronze torcs and a bronze pin were found in parish of Orsett and these objects were presented to the Victoria and Albert Museum in 1901. The exact discovery site of these objects is unknown.
- 1.4.9 **Iron Age.** The Neolithic causewayed enclosure located 100m to the north of the site was overlain by an unenclosed early Iron Age site and a middle Iron Age sub-rectangular enclosure (Hedges and Buckley 1978, 219-308). Cropmarks including pits, linear features and ring-ditches extend from the area of the scheduled early Iron Age enclosure (Place Services 2019, sites 17A, 17B and 72). Another early Iron Age open settlement was excavated 800m

north-west of Land Parcel 4. This excavation found a scatter of postholes and pit, including a storage pit floored by carbonised grain (Wilkinson 1988, site 1).

- 1.4.10 A large quantity of high-status Iron Age material was recovered by metal detectorists within a field close to Hornsby Lane and c 400m west of the site.
- 1.4.11 A cello-shaped enclosure of possible Iron Age date is located c 400m south-west of the land parcel. It contains several ring-ditches possibly representing house enclosures (Place Services 2019, sites 22 and 32). Further east, and 150m south of Land Parcel 4, another enclosure was identified. This rectangular enclosure with a sub-rectangular annexe may be Iron Age to Roman in date.
- 1.4.12 **The Roman period.** The route of a possible Roman road is projected roughly north-south through the north-eastern part of Land Parcel 4. It is possible that additional Roman roads or trackways cut roughly east-west across the terrace as other Roman sites have been identified 1.5-2km north-west of the land parcel.
- 1.4.13 An extensive cropmark complex that includes one very large rectilinear enclosure and several smaller ones linked by trackways or field boundaries was identified by the aerial survey c 0.4km to the west of the site (Place Services 2019, site 20). The large enclosure is on a north-west to south-east alignment and contains sub-divisions, pits and curvilinear smaller enclosures. A number of other linear boundaries surrounding the enclosure run parallel and perpendicular to it and these may be associated field systems and additional enclosures.
- 1.4.14 Several copper coins of Carausius, indicating possible later 3rd century Roman activity within the vicinity, were found in this general area in 1906 but the exact find location is unknown.
- 1.4.15 **The medieval period.** Mid-Saxon activity has been identified to the north of the site. The Orsett causewayed enclosure, c 0.1km to the north, was reused as a Saxon funerary monument in the 7th-8th century. A Saxon settlement was also located 1km north-east of the site at Orsett Cock. The nucleated medieval settlement of Orsett was located 1km north of the land parcel. It is likely that in the later medieval period the land parcel was used as agricultural land associated with this settlement.
- 1.4.16 **Post-medieval period.** Documentary evidence indicates that the land parcel was situated west of Brentwood Road which linked Brentwood to Chadwell. The land parcel was also located c 600m south of the NE-SW road from Stifford to Stanford. The Ordnance Survey (OS) map of 1897 indicates that the town of Chadwell St Mary's was located 1.3km south-west of the site. The site itself was in a rural location at the south-eastern edge of the parish of Orsett.
- 1.4.17 The site of the medieval to post-medieval manor of Seaborough Hall was located within the northern limit of the land parcel and west of Brentwood Road. This hall is first mentioned in the 13th century and it appears on the OS map of 1897. This manor house was demolished in the 20th century and all that remains is a wall adjacent to Brentwood Road (Thurrock Local History Society 2019).
- 1.4.18 In the early 19th century the site was divided into four separate fields and was used as agricultural land associated with Seaborough Hall. This is confirmed

by the c 1840 Tithe map of Orsett (D/CT 264/1a) which shows the site as four fields labelled 241-244. It is almost certain that roughly east-west and north-south cropmarks identified by the aerial mapping survey are those shown on the c 1840 Orsett Tithe map (Place Services 2019, site 18).

- 1.4.19 **Undated features and cropmarks.** Apart from the linear east-west and north-south aligned cropmarks that are likely to represent post-medieval field boundaries, a number of undated discrete and short linear features were identified across the site by the aerial survey. It is possible that some of these features may be prehistoric in date, or they could be natural and relate to colluvial processes.

## 2 Project Aims

---

### 2.1 General aims

2.1.1 The general project aims of the project were as follows:

- To establish the presence or absence of archaeological remains along the line of the scheme, and the extent of any areas where remains appear likely to be absent;
- In areas where archaeological remains are known or suspected, to clarify the reliability of the cropmark or geophysical survey evidence;
- In areas where no archaeological remains are indicated by aerial or geophysical survey, to clarify whether this apparent absence of remains is genuine;
- To determine the degree of complexity of any surviving horizontal or vertical stratigraphy and in particular to investigate areas where topography indicates the likelihood of deep deposit sequences for evidence of buried archaeological horizons and palaeo-environmental sequences;
- Where remains are present, to determine the period(s) represented, the extent, state of preservation and character of the archaeological remains;
- To establish the range and state of preservation of archaeological artefacts, and through their recovery and examination, to establish the potential for information about the economy, status and contacts of past inhabitants of the scheme footprint;
- To determine whether palaeo-environmental remains are preserved, and, where these are found, to determine their types (e.g. charred plant remains, waterlogged remains, molluscan remains), state of preservation and potential for environmental information. This will be achieved through the recovery of samples from sedimentary sequences and archaeological features suitable for assessment of a range of palaeoenvironmental remains (e.g. charred and waterlogged plant remains, charcoal, insects, pollen, diatoms, ostracods/foraminifera and molluscs) and scientific dating (e.g. radiocarbon and OSL dating);
- To investigate and record the extent, character and chronology of the sedimentary sequences, particularly those immediately adjacent to and in floodplains, contained within palaeochannels or in dry valleys, and to use the data to refine existing geoarchaeological (predictive) deposit models.
- To place any identified archaeological remains into their local and, where appropriate, regional or national context, and to assess the implications of any such discoveries for our current understanding of settlement and landscape change in the area, including an assessment of the associations of any remains with reference to the historic landscape;
- To provide sufficient information to enable the LTC archaeological advisor, in consultation with the Key Archaeological Stakeholders, to determine the significance of the archaeological assets identified within the land parcel;

- To provide a report on the discoveries to inform the Environmental Statement (ES) supporting the Development Consent Order (DCO) and support the preparation of a further archaeological mitigation strategy for the Enabling Works and Construction phases of the scheme;
- Following the DCO, to deposit the report in the public domain, and to generate an accessible and useable archive which will allow future research of the evidence to be undertaken.

## 2.2 Specific objectives

2.2.1 The specific project objectives were as follows:

- To conduct the programme of archaeological investigation within the general research parameters and objectives defined by the revised East of England Research Framework (Medlycott 2011), and to take account of the aims and objectives of the Greater Thames Estuary Historic Environment Research Framework.
- To clarify whether the cropmarks provide an accurate representation of the range, quantity and types of archaeological features present within the land parcel;
- For the late Upper Palaeolithic, Mesolithic and Neolithic periods, to investigate landscape processes, and in particular, the potential for sites being eroded and buried beneath colluvium or Head deposits at the foot of slope areas (Aims C.6 and C.7), and for the survival of undisturbed occupation surfaces below colluvium or beneath later alluviation in the Mar Dyke and Thames floodplains.
- To investigate whether there was associated activity carried out around the Neolithic causewayed enclosure;
- To clarify the date of the two ring ditches, and to investigate activity around them, particularly whether peripheral burials, pit deposits related to visits, or reuse for burial or other purposes occurred contemporarily or in later periods.
- To establish the character and date of the extensive pits across the land parcel, and to determine whether these are all of one type or period, or whether they encompass several types and span several periods of activity;
- To establish the extent, character and density of Roman activity within the scheme area, and in particular, whether the undated cropmark enclosures are Roman, and if so, establish their duration of use.
- To establish the date of the possible medieval or post-medieval field boundaries that have been identified within the land parcel;
- To establish whether a possible medieval droveway extends northwards through the land parcel;
- To look for evidence of medieval and post-medieval farmsteads which may have been located along the roadways within the northern and western part of the land parcel.

- Should any of the trenches prove to overlie sequences of colluvial deposits in the dry valley, to look for buried archaeological horizons within the colluvial sequence.

## 3 Methodology

---

### 3.1 Constraints

- 3.1.1 Several constraints limited the area of the land parcel available for trial trenching. These comprised buried and overhead services, unexploded ordnance (UXO) and ecological constraints. The buried services comprised telecom cables and irrigation channels present along the eastern boundary with Brentwood Road. Two parallel arrangements of high voltage overhead electricity cables were also present bisecting the site on a WNW-ESE alignment.
- 3.1.2 The UXO survey identified the locations of two possible unexploded bombs within the western and north-eastern part of the land parcel. The trench layout was designed to avoid this area of risk.
- 3.1.3 Three individual ecological constraints were located in close proximity to the site, one to the north-west and two to the north-east. There are also two small ponds within the site, including one to the north-western and one within the eastern part of the site. The trench layout was arranged to take into consideration all of the constraints prior to commencing the trench set out and excavation.

### 3.2 Methodology for the evaluation

- 3.2.1 The total land parcel area was 21.47ha in extent, and the area available for investigation (excluding areas of services, hedgerows and other constraints) was 20.02ha. The archaeological trial trenching comprised a total of 139 trenches, most measuring 30m x 2m, and a small number measuring 40m or 20m x 2m, representing a 3.7% sample of the area available for trenching. The final locations of the trenches are shown on Figure 2.
- 3.2.2 The trench design was developed to target cropmark features identified by the aerial mapping report (Place Services 2019), and otherwise to provide an even coverage of the blank areas. Trenches were located to investigate both ring-ditches and the adjacent areas, as well as to target the parallel linear features in the north-west and other linear and discrete features.
- 3.2.3 All trenches were located using a Global Positioning System (GPS) prior to machine excavation and were excavated under constant archaeological supervision using a tracked mechanical excavator fitted with a toothless bucket.
- 3.2.4 Any features revealed in the trenches were hand cleaned and sampled by hand excavation and recorded as outlined within the approved WSI. All finds were bagged by context throughout the evaluation and were recovered for further investigation.



## 4 Results

---

### 4.1 Introduction and presentation of results

- 4.1.1 The results of the evaluation, including a stratigraphic description of the trenches that contained archaeological remains, are presented below. Full details of all trenches, including dimensions and depths of all deposits can be found in Appendix A. Finds data and spot dates are presented in Appendix B with the environmental reports presented in Appendix C.
- 4.1.2 Context numbers reflect the trench numbers unless otherwise stated, for example pit 102 is a cut within Trench 1, while ditch 10304 is a cut within Trench 103.
- 4.1.3 An overview of the results for the site along with the cropmark evidence is shown on Figure 2. Further detailed plans of the trenches which contained archaeological features are contained in Figures 3-18 and selected sections are shown on Figures 19 and 20.

### 4.2 General soils and ground conditions

- 4.2.1 The soil sequence varied across the site with the natural geology comprising silty sand with gravels and clayey silt deposits. A borehole recorded by the British Geological Survey on the northern edge of the site (TQ68SE109 at 565130,180290) indicates that the Boyn Hill sand and gravel extends c 1.5m below the surface in this area. This suggests that only this surface geology was encountered during this evaluation, and that some of the geological variation within the site may be heavily influenced by the dry valley deposits as well as the change at the northern edge of the site from Thanet Sand bedrock to the more mixed Lambeth Group deposits comprising a mixture of clay, silt and sand.
- 4.2.2 Subsoil and slope deposit layers ranging between 0.25-0.7m thick were encountered across the site, with the thicker slope deposit sequences located in trenches along the northern edge of the site within the lowest points of the dry valley identified by the LiDAR data. The shallower subsoils are more likely to represent the relict remains of a former ploughsoil which now lies below the depth of the current plough depths.
- 4.2.3 Slope deposits and/or colluvial sequences were recorded in a total of 35 trenches, mostly towards the northern and eastern extents of the land parcel. This broadly matches the extent of the dry valley mapped by the LiDAR data.
- 4.2.4 The topsoil consisted of mid grey brown silty clay or silty sand measuring between 0.24-0.4m thick.
- 4.2.5 Ground conditions throughout the fieldwork were occasionally poor, with frequent persistent rain resulting in waterlogged soils and locally flooded trenches. However, archaeological features, where present, were relatively easy to identify during the initial machine excavation against the underlying geology. Several silty areas identified within the trenches, some matching large discrete cropmarks, were investigated and proved to be of natural origin.

## 4.3 General distribution of archaeological deposits

- 4.3.1 Archaeological features were encountered in 43 of the trenches, with clusters of activity in the south-east corner as well as the westernmost part of the site.
- 4.3.2 The evaluation confirmed the presence of several linear features within the site which had previously been identified as cropmarks (Place Services 2019). These features, discussed in more detail below, are likely to be representative of post-medieval field boundaries.
- 4.3.3 Trenches 1, 2, 3, 5, 7, 8, 13, 14, 20, 21, 22, 27, 28, 29, 30, 31, 32, 33, 34, 35, 44, 45, 48, 59, 132, and 134 contained only deep slope and colluvial deposits, with some also including areas of natural variation and/or root disturbance.
- 4.3.4 Trenches 12, 18, 64, 65, 66, 67, 70, 71, 74, 93, 102, 104, 107, 108, 109, 116 revealed only natural features. These were confirmed by hand excavation through slots 1203, 1803, 6403, 6503, 6603, 6703, 7004, 7403, 10403, 10703, 10803, and 11603.
- 4.3.5 No features or colluvial/head deposits were encountered in Trenches 4, 6, 9, 10, 16, 26, 38, 40, 41, 42, 43, 46, 50, 53, 55, 56, 57, 60, 68, 69, 75, 77, 78, 79, 81, 82, 84, 85, 86, 87, 88, 89, 90, 91, 92, 94, 95, 98, 100, 101, 103, 105, 106, 110, 123, 126, 127, 128, 129, 131, 135, 136, and 137.

## 4.4 Trench 11

- 4.4.1 The terminus of a NE-SW aligned ditch (1103) was investigated near the southern end of Trench 11 (Fig. 2). The feature measured 2m wide and 0.37m deep. It had steep sides and a flat base and contained a single sterile fill.
- 4.4.2 The ditch coincided with a cropmark but was not observed in any other trenches.

## 4.5 Trench 15

- 4.5.1 A NE-SW aligned ditch (1503) was revealed in Trench 15 (Fig. 2). It measured 0.65m wide and 0.36m deep and contained a single sterile deposit. The feature cut an earlier ditch (1505), which measured 2.6m wide and 0.22m deep and was filled with two sterile deposits.

## 4.6 Trench 17

- 4.6.1 Trench 17 contained a NE-SW aligned ditch (1703) within the southern end of the trench. The feature was broad and relatively shallow, measuring 1.41m wide and 0.23m deep and had convex sides and a concave base. It was filled with two sterile fills. This ditch was not observed running through any of the adjacent trenches (Fig. 2)

## 4.7 Trench 19

- 4.7.1 A large pit (1903) was partially exposed in the northern end of Trench 19 (Fig. 3). The visible extent of the feature measured 3.46m wide and more than 0.56m deep (Fig. 19 Section 1900); the base of the feature was not reached due to maximum depth restrictions limiting excavation to a total depth of 1m below the modern ground level. The steep-sided pit contained at least three fills (1904, 1905 and 1906), which produced a small assemblage of early Neolithic pottery (11 sherds, 31g) and worked flint. The deposits may

represent a mix of primary slumping (1906) and secondary, possibly deliberate, backfilling (1904, 1905). The upper fill (1904) also contained frequent charcoal and a single fragment of charred hazelnut shell was recorded in the environmental sample.

- 4.7.2 The sharp angles of the fills are, possibly, indicative that the feature was recut several times. However, this could not be conclusively established within the limitations of the evaluation.

## 4.8 Trenches 22, 23 and 24

- 4.8.1 The remains of a NW-SE aligned post-medieval field boundary ditch visible on the 1888-1916 OS maps were encountered in Trenches 22, 23 and 24 (Fig. 4). The feature was sample excavated in Trench 23 (2305). It measured 2.6m wide and more than 0.8m deep, and had irregular sides and at least three sterile fills (Fig. 19 Section 2300; Plate 1). Due to excavation depth restrictions the base of the ditch was not excavated.

## 4.9 Trench 25

- 4.9.1 Two intercutting pits (2502 and 2504) were encountered at the western edge of Trench 25 (Fig. 5). The earlier of the two features, pit 2502, measured 1.26m long, 0.58m wide and was 0.2m deep. This had steep sides and a flat base; this was filled with a single deposit that contained charcoal and burnt, unworked flint but lacked datable material (Fig. 19 Section 2500).
- 4.9.2 Pit 2504 measured 0.83m long, 0.74m wide and 0.28m deep. It had moderately steep sides and a concave base, containing a single sterile fill that.

## 4.10 Trench 36

- 4.10.1 A cluster of five pits of varying sizes was encountered in the western half of Trench 36 (Fig. 2). Pit 3606 was sample excavated and was found to measure 1.28m long, 0.76m wide and more than 0.12m deep. The pit could not be investigated to its full depth due to the restriction imposed on combined trench and feature depths limiting excavation to 1m below the modern ground level. The fill (3607) was ashy and charcoal-rich with fired clay inclusions (Plate 2). This lacked any other artefactual evidence.
- 4.10.2 The other features (3604, 3605, 3608 and 3609) were recorded in plan, with 3608 and 3609 also partially recorded in the baulk section of the trench. Combined, and if contemporary or otherwise associated, the pits appeared to be laid out in a semi-circular arrangement, perhaps forming part of a pit circle with a diameter of approximately 7m.

## 4.11 Trench 37

- 4.11.1 Three ditches, all aligned NW-SE, were investigated in Trench 37. Although no cropmarks were evident within the land parcel 4 boundary, these do correspond to a ditch alignment visible within the land parcel 3 boundary to the north-west (Fig. 2). These ditches were investigated as part of the Hornsby Lane evaluation (LTC3HL 19, Trench 55), although they did not produce any dating evidence.

- 4.11.2 Within Trench 37, the westernmost ditch (3702) measured 0.58m wide and 0.12m deep. It contained a single fill that yielded a small assemblage of pottery (4, 9g) tentatively dated to the late Bronze Age to Iron Age.
- 4.11.3 Ditches 3704 and 3706 were observed to partially overlap at the southern side of the trench, with 3704 representing the later phase. The ditch measured 1.15m wide and 0.14m deep and had moderately steep sides and a flat base; the single fill did not contain any finds.
- 4.11.4 Ditch 3706, representing the easternmost of the three linear features, measured 1.75m wide and 0.31m deep. The single fill (3707) yielded an assemblage of terminal late Iron Age to early Roman pottery (85, 218g).
- 4.11.5 It is likely that ditches 3704 and 3706 represent two phases of a ditch alignment which continues from the adjacent land parcel to the west (land parcel 3).

## 4.12 Trench 39

- 4.12.1 Trench 39 contained three intercutting pits or postholes (3903, 3905, 3907) which yielded no artefactual remains (Fig. 2). Possible posthole 3903 measured 0.44m long, 0.18m wide and 0.23m deep. This was truncated by pit 3907, which measured 0.62m long, 0.55m wide and 0.21m deep. It had steep sides and a concave base and contained a single fill. Pit 3907 cut the southern side of pit 3905, which measured 1.22m long, 0.91m wide and 0.32m deep. It had slightly irregular sides and base filled with a single deposit.

## 4.13 Trench 47

- 4.13.1 A N-S aligned ditch (4703) was investigated in Trench 47 (Fig. 6). The feature measured 1m wide and more than 0.82m deep. It had steep sides and was observed to have cut through the subsoil layer, suggesting a relatively recent date. Some flint flakes were recovered from the single fill (4703), but it is likely that these are residual.

## 4.14 Trench 49

- 4.14.1 Trench 49 contained a single E-W aligned ditch (4903), which measured 1.06m wide and 0.4m deep. It had steep sides and a narrow, rounded base. This contained a single fill (4904) that did not produce any finds.

## 4.15 Trench 51

- 4.15.1 Trench 51 contained two small pits and a ditch (Fig. 7). A small near-circular pit (5103) had a diameter of 0.6m and was 0.1m deep with a flat base. The single fill (5104), likely to have been formed through deliberate deposition, contained a moderate assemblage of worked flint (Plate 3) accompanied by a small assemblage of plain early Neolithic pottery sherds (10, 19g). The flint assemblage was notable for the high incidence of tools amongst the flake-based assemblage, including one derived from a ground or polished artefact. This deposit also contained charred remains with many small fragments of charcoal present alongside many fragments of hazel nut and a single grain. The provenance of the grain may be questionable given the incidence of modern seeds within the environmental sample.

- 4.15.2 Pit 5105, located further north and only partially extending into the trench from the eastern baulk section, measured 0.46m wide and 0.38m deep (Fig. 19 Section 5100). The northern part of the cut displayed a moderate slope towards the concave base of the feature, while the southern side slightly undercut itself (Plate 4). The single fill (5106) produced no finds.
- 4.15.3 A shallow NW-SE aligned ditch (5107) was also encountered in the southern part of the trench. The feature measured 0.74m wide and 0.14m deep and was filled with a single sterile deposit (5108).

## 4.16 Trench 52

- 4.16.1 Trench 52 revealed two pits, located within the easternmost end of the trench. Pit 5203 appeared oval in plan, measuring 0.66m long and 0.4m wide. This was very shallow being only 0.08m deep and it contained a single sterile fill.
- 4.16.2 A second pit (5205) was only partially exposed within the trench. The visible extent measured 0.97m wide and 0.48m deep. It had steep sides and a flat base and was filled with a single deposit (5206) that yielded a worked flint.

## 4.17 Trench 58

- 4.17.1 Trench 58 contained a single oval pit (5804) near the southern baulk (Fig. 2). The feature measured 0.81m long, 0.56m wide and 0.16m deep, with a steeply sloping NW side, leading onto a concave base, and a very gentle slope to the SE where the feature continues beyond the limits of the trench. The pit was filled with a single sterile deposit (5805).

## 4.18 Trench 62

- 4.18.1 A total of six features were encountered in Trench 62, comprising five ditches and one pit (Fig. 8). The ditches shared a common NW-SE alignment and were spaced apart from each other. These ditches may be related to those identified in Trench 37, despite the absence of any features in the intervening Trench 50.
- 4.18.2 Ditch 6203 crossed the eastern end of the trench and measured 1.41m wide and 0.37m deep (Fig. 19 Section 6200). The lower of two fills (6204) contained two worked flints.
- 4.18.3 Further to the west, ditch 6206 was larger measuring 2.03m wide and 0.17m deep. It had moderately steep sides and a broad, flat base (Fig. 19 Section 6201). The feature contained two sterile fills.
- 4.18.4 Pit 6209 extended partially into the trench from the southern edge of the trench. The visible extent of the pit measured 0.48m long, at least 0.28m wide and 0.24m deep. It had steep, concave sides and a flat base. No finds were encountered in the single fill (6210).
- 4.18.5 Immediately to the west, a ditch, displaying much smaller dimensions, terminated near the centre of the trench (6211). This measured 0.29m wide and 0.07m deep with a rounded profile. It contained a single sterile fill.
- 4.18.6 Another small ditch (6213) to the west of 6211 measured 0.37m wide and 0.14m deep with a similar profile to that of 6211. The feature contained a single fill (6214) which yielded worked flint.

- 4.18.7 At the western end of the trench, ditch 6215 extended on the same NW-SE alignment as the other features. It measured 1.07m wide and 0.16m deep and had moderately sloping sides and a flat base. The feature was filled with a single sterile deposit.

## 4.19 Trenches 61 and 63

- 4.19.1 Trenches 61 and 63 (Figs 2, 8 and 9) tracked a NW-SE-aligned ditch (6103 and 6303) measuring 0.68-1.02m wide and 0.14-0.36m deep. It had steep sides and a flat base containing a single sterile fill. The ditch is likely to form part of a system of post-medieval field boundaries, with the alignment broadly matching that of the boundaries mapped in the adjacent field to the west.

## 4.20 Trench 72

- 4.20.1 A cluster of pits was investigated in Trench 72 (Fig. 2). Intercutting pits 7203 and 7206 were located near the middle of the trench, with pit 7206 having been cut by the later feature 7203. Pit 7203 measured 1.71m long, 1.45m wide and 0.52m deep. It had steep sides and a flat base. No finds were recovered from either of its two fills (7204 and 7205). The remains of pit 7206 measured 0.67m long, 0.38m wide and 0.22m deep. Its single, partially surviving fill produced no finds.
- 4.20.2 Pit 7209 was located further west, and only partially extended into the trench; the feature's visible extent measured 1.78m long and 0.33m deep. The pit was filled with two distinct deposits, neither of which produced any finds.

## 4.21 Trench 73

- 4.21.1 Trench 73 contained a single feature in the form of a NW-SE-aligned ditch (7303). The feature measured 0.63m wide and 0.37m deep and had a V-shaped profile. The feature contained a single sterile fill.

## 4.22 Trench 80

- 4.22.1 Trench 80 (Fig. 10) revealed a shallow oval pit (8003) measuring 1.3m long and 0.14m deep. It had gently sloping sides and a flat base containing a single. The feature contained a single fill (8004) which produced a small assemblage of probable late Neolithic pottery (12 sherds, 24g) and a single worked flint. A sample recovered from the fill produced some poorly preserved charcoal but lacked any other remains of note.
- 4.22.2 The fill of a large treehole (8005) located to the west of the pit also yielded a few very small and abraded fragments of possible Neolithic or late Bronze Age to Iron Age pottery (5 sherds, 4g).

## 4.23 Trench 83

- 4.23.1 A single posthole was encountered in Trench 83. This was generally unremarkable, measuring 0.27m long, 0.2m wide and 0.08m deep and containing a single sterile fill.

## 4.24 Trench 96

- 4.24.1 The terminus of a NW-SE aligned ditch (9603) was investigated in Trench 96. It measured 1.07m wide and 0.27m deep and had steep sides and a concave base. Although the feature contained two fills no finds were recovered.

## 4.25 Trench 97

- 4.25.1 Trench 97 revealed one ditch (9703), which crossed the trench on a NE-SW alignment. It measured 1.88m wide but owing to maximum depth restrictions, the base was not reached. However, its steep sides suggest a substantial depth. The feature was filled with at least one deposit. This contained no finds, although charcoal flecks were noted.

## 4.26 Trench 99

- 4.26.1 Three features were encountered in Trench 99, comprising a ditch (9902) and two pits (9904 and 9906). Ditch 9902 was observed running on an ESE-WNW alignment corresponding to a cropmark. This was also excavated as ditch 12202 in Trench 122 to the west. Within Trench 99, this ditch had moderately sloping sides and a concave base and measured 1m wide and 0.35m deep (Fig. 20 Section 9900). No finds were recovered from the single fill.
- 4.26.2 Pit 9904 only partially extended into the trench from the northwest baulk section. The feature's visible extent measured 1.1m long, 0.75m wide and 0.36m deep. It had moderately sloping concave sides and a concave base. The single fill produced no finds.
- 4.26.3 Modern pit 9906 measured at least 2m long, 1.8m wide and more than 0.66m deep (Fig. 20 Section 9902; Plate 5); due to maximum excavation depth restrictions the base of the feature was not reached. A total of seven deposits (9907-9913) fill the pit, with some containing modern bottle glass and metal fragments.

## 4.27 Trench 111

- 4.27.1 Trench 111 revealed a single N-S aligned ditch (11103) measuring 0.91m wide and 0.35m deep. It had steep, slightly convex sides and a concave base and was filled with a single sterile deposit (11104).

## 4.28 Trench 112

- 4.28.1 A NW-SE aligned ditch (11203) was encountered in Trench 112 (Fig. 2). This measured 1.92m wide and more than 0.19m deep; due to maximum excavation depth restrictions, the feature was not fully excavated. It had steeply sloping concave sides and was filled with three deposits. Contexts 1204 and 11205 were possibly representative of sterile primary slump deposits while likely silting fill 11206 contained worked flint and fragments of amorphous fired clay.

## 4.29 Trenches 54, 76 and 113

- 4.29.1 The line of a NNE-SW-aligned ditch was encountered in Trenches 54, 76 and 113, corresponding with a linear cropmark (Figs 2 and 11). Hand-investigated slots showed that the feature measured between 0.7-0.82m wide and 0.2-

0.32m deep. It had steep sides and a concave base (Fig. 20 Section 11300). This was filled with a single deposit that yielded an 18th-19th-century fragment of flat roof tile from cut 7605.

- 4.29.2 While the feature was not identified in Trenches 22, 30 and 94, it is likely that it did continue across the area in the way indicated by the cropmark data, and that variations in depth and preservation levels may account for the loss of the feature in Trenches 22 and 94, whereas Trench 30 may have been positioned in a way that narrowly missed the feature.
- 4.29.3 A broad and shallow hollow way (5405) was recorded in the western part of Trench 54. This measured in excess of 4.5m wide but only 0.35m deep. This was aligned NE-SW and possibly continued in Trench 15 as feature 1503 (Fig. 2). The excavated fill did not produce any dating evidence

### **4.30 Trench 114**

- 4.30.1 Trench 114 revealed two linear features. Ditch 11403, running on a NE-SW alignment, measured 0.72m wide and 0.47m deep. It had steeply sloping concave sides and a concave base. The feature was filled with a single sterile deposit (11404).
- 4.30.2 Ditch terminus 11405 was aligned N-S. It measured 0.9m wide and 0.6m deep and contained a single fill (11406), which produced no finds.

### **4.31 Trench 115**

- 4.31.1 A single pit (11503) was investigated in Trench 115 (Fig. 12). It measured 0.88m long, 0.74m wide and 0.14m deep and had steep sides and a slightly uneven base (Fig. 20 Section 11500; Plate 6). The feature contained a single fill (11504), which contained frequent charcoal and burnt flint, none of which was worked.

### **4.32 Trench 117**

- 4.32.1 Trench 117 revealed one ENE-WSW aligned ditch (11703), which measured 0.6m wide and 0.26m deep. This contained a single sterile fill (11704).

### **4.33 Trench 118**

- 4.33.1 The terminus of a curvilinear ditch (11802) was observed in Trench 118 (Fig 13). This curved westwards from the southern edge of the trench before terminating. The feature measured 0.86m wide and 0.45m deep. It had moderately steep sides and a concave base and was filled with a single sterile deposit (11803).
- 4.33.2 A possible pit (11804) was investigated further to the west. The oval feature, measuring 3.7m long, 1.1m wide and 0.45m deep, was aligned along a roughly E-W axis, and contained a single sterile fill (11805).
- 4.33.3 Near the eastern of the trench, former field boundary 11807 extended across the eastern end of the trench on a slightly irregular N-S alignment. The feature, likely to be representative of a former hedge-line, measured 0.8m wide and 0.49m deep. It had an irregular V-shaped cut, which was filled with a single sterile deposit.



## 4.34 Trench 119

- 4.34.1 Trench 119 revealed two linear features (Fig. 2). The terminus of NE-SW-aligned ditch 11902 extended into the trench at its northern end; the feature measured 1.36m wide and 0.18m deep, and had moderately steep sides and a flat base. Its single fill (11903) contained no finds.
- 4.34.2 Further to the south, shallow ditch 11904 crossed the trench on an E-W alignment. It measured 0.96m wide and 0.07m deep and contained a single fill (11905) which produced no finds.

## 4.35 Trench 120

- 4.35.1 Remains of three ditches and two pits were encountered in Trench 120 (Fig. 14). Ditches 12002 and 12004 entered the trench from the west, running on a roughly E-W alignment before terminating. The northernmost of the two, ditch 12002, measured 0.61m wide and 0.22m deep. It had moderately sloping sides and a flat base, while ditch 12004 measured 1.1m wide and 0.12m deep and had a profile. No finds were recovered from either feature.
- 4.35.2 The two ditch terminals appeared to respect the line of a third ditch (12008) which crossed the trench on a NNW-SSE alignment, measuring 0.98m wide and 0.3m deep. The feature contained a single sterile deposit (12009).
- 4.35.3 Ditch 12008 cut two pits. The smaller of the two (12006) was investigated on the eastern edge of the ditch, and measured 0.88m long, 0.71m wide and 0.18m deep. It had concave sides and a concave base. Its single fill contained no finds.
- 4.35.4 On the western side of the ditch, pit 12010 measured 2.18m long, 1.1m wide and 0.2m deep. It had gently sloping sides and a concave base. The feature contained a single fill which produced no finds.

## 4.36 Trench 121

- 4.36.1 Trench 121 revealed five ditches, two of which were not excavated (Fig. 14).
- 4.36.2 Curving ditch 12102 matched a large circular cropmark at the northeast end of the trench. The feature measured 2.12m wide and 0.72m deep and had slightly convex sides and a narrow base (Fig. 20 Section 12100). This was filled with two deposits (12103 and 12109). The lower fill (12103) was notable for the frequent inclusion of large natural pebbles. This also yielded three small worked flints and a small amount of charcoal from the environmental sample.
- 4.36.3 Ditch 12104 crossed the southwest half of the trench on a NW-SE alignment. It measured 1.24m wide and 0.28m deep and had steep sides and a narrow, concave base. The cut was filled with a single sterile deposit. While the feature matches a linear cropmark which continues further northwest, it was not encountered in any other trenches.
- 4.36.4 At the southwest end of the trench, a curvilinear ditch (12106) was exposed. It measured 1.18m wide and 0.48m deep and had a steep-sided, U-shaped cut. No finds were recovered from either of the two fills, and the feature does not appear as a cropmark.

## 4.37 Trench 122

- 4.37.1 Trench 122 was positioned to further identify the ring ditch excavated in Trench 121 (Fig. 14). A curving ditch (12204) was correspondingly exposed in the northern end of the trench, although this was not excavated to avoid unnecessary intrusion into the feature following its positive identification in Trench 121.
- 4.37.2 A shallow NW-SE aligned ditch (12202) was investigated near the southern end of Trench 122. The feature, continuing to the east through Trench 99 (ditch 9903), measured 0.78m wide and 0.18m deep (Fig. 20 Section 12200; Plate 7). It had moderately sloping sides and a slightly irregular base. A single fill (12203) yielded a worked flint.

## 4.38 Trench 124

- 4.38.1 Trench 124 revealed a single ditch (12403), which crossed the trench on a NW-SE alignment, matching an L-shaped cropmark also investigated in Trench 125 (Figs 2 and 15). The feature measured 2.28m wide and 0.4m deep and contained a single fill (12404) that yielded a small assemblage (6 sherds, 13g) of middle Iron Age pottery.

## 4.39 Trench 125

- 4.39.1 Ditch 12502 represents the NE-SW aligned return of the ditch investigated in Trench 124. Within Trench 125, the feature measured 1.6m wide and 0.55m deep and contained three fills from which an assemblage of 32 sherds of pottery (54g) was recovered dating to the middle Iron Age.

## 4.40 Trench 130

- 4.40.1 A single ditch (13002) was revealed at the western end of Trench 130 (Fig. 16). It measured 0.7m wide and 0.26m deep. The feature contained a single sterile fill.

## 4.41 Trench 138

- 4.41.1 Trench 138 contained the truncated remains of two parallel NE-SW aligned walls (Fig. 17). The northernmost wall (13803) comprised one surviving course of red brick, bonded with light cream-coloured mortar with small grit inclusions, with evidence of shaped flint facing on the southern side. In the middle of the trench, the line of the wall was interrupted by a sub-square concrete slab, likely to be a lintel marking a passage or doorway.
- 4.41.2 The wall to the south (13807) was constructed of matching brick and mortar but appeared to lack the distinctive facing of flint nodules observed on the other wall line. Tile and brick recovered from this trench suggests that only the late phases of structural evidence dating from the 19th-20th century survive.
- 4.41.3 Both walls closely match the building layout for Seaborough Hall, marked on the 1st Edition Ordnance Survey map. It is likely that the possible beam-slots and other features observed in Trench 139 also relate to activity connected with the occupation of these buildings.

## 4.42 Trench 139

- 4.42.1 Several possible beam-slots were recorded at the north end of Trench 139 (Fig. 18). The features appeared evenly spaced at intervals of roughly 0.3m apart, on NW-SE alignments.
- 4.42.2 The trench also contained a single NW-SE aligned ditch (13922) further to the south. The feature measured 2.17m wide and 0.18m deep. A range of brick and tile largely dating to the 18th-19th centuries was recovered from various deposits within this trench consistent with the material recovered from Trench 138.
- 4.42.3 A single, poorly defined pit (13928) was notable for the consistently earlier range of artefacts that it yielded (not illustrated). This pit was at least 0.8m in diameter and 0.3m deep and filled with a single deposit that yielded pottery and tile fragments dating to the later medieval or early post-medieval periods (c 1480-1600). A copper alloy dress pin of a similar manufacture date was also recovered from this deposit. This small assemblage is notable as it identifies the probability of a structure being present here in the late medieval period.

## 4.43 Finds summary

- 4.43.1 **Prehistoric pottery.** The evaluation recovered 81 sherds of prehistoric pottery from 11 contexts across seven trenches. Three periods were represented: the early Neolithic (c 3900-3200 BC), from Trenches 19, 51 and 80, probably the late Neolithic (c 2900-2100 BC), from Trench 80, and the middle Iron Age (c 350-50 BC), from Trenches 24, 124 and 125.
- 4.43.2 **Late Iron Age and Roman pottery.** The Roman pottery was recovered from Trench 37 and appears to be from a single bead-rimmed jar in medium to fine oxidised ware. A small portion of the rim is present, along with part of the footing base and small body sherds. The vessel dates to the 1st to mid-2nd century AD.
- 4.43.3 **Post-medieval pottery.** Four fragments of post-medieval domestic wares were recovered from Trenches 66 and 139, including transfer-printed ware and red earthenware.
- 4.43.4 **Clay pipe.** A broken and very abraded fragment from the back of a pipe bowl of later 17th- or early 18th-century style was recovered in Trench 13.
- 4.43.5 **Ceramic building material.** A total of 37 fragments of 18th- to 20th-century ceramic building materials were recovered from Trenches 24, 76, 138 and 139. The material included flat roof tiles, peg tiles as well as a stoneware drainpipe.
- 4.43.6 **Fired clay.** A small quantity of fired clay was recovered from Trenches 36 and 112. The material is amorphous, of indeterminate form or function, and is likely to derive from a hearth or similar domestic structure.
- 4.43.7 **Stone.** Two pieces of stone were recovered. One, recovered from Trench 51, is a nodule of flint with coarse battering damage at one end, suggesting use as a heavy grade hammerstone. A larger nodule of flint from Trench 138 has been shaped for use in construction, and still retains mortar on two surfaces evidencing this function.

- 4.43.8 **Animal bone.** Four animal bone fragments were recovered from Trenches 24, 76 and 99, including three small fragments of mammal long bone and a better-preserved right femur of a mid-sized bird, probably partridge.

## 4.44 Environmental summary

- 4.44.1 Recovery of charred material on site is limited to charcoal from most features, the majority of which are currently undated. Individual cereal grains have been identified in samples 2, 3 and 6 and nutshell in early Neolithic samples 2 and 5. If securely dated as early Neolithic then the cereal grain is significant, but the possibility of intrusion cannot be ruled out. Unfortunately, the individual grains are likely to be of insufficient weight for radiocarbon dating. Samples 1, 2, 9 and 11 include material likely to be suitable for radiocarbon dating, and a few other samples may include suitable material.

## 5 Discussion

---

### 5.1 Reliability of field investigation

- 5.1.1 The archaeological features were reasonably well defined against the underlying Boyn Hill Gravel, although some deposits were sample excavated to establish if they were of geological or archaeological significance. In all examples, hand-excavation confirmed the initial interpretations.
- 5.1.2 There was a correlation between the aerial survey cropmarks and the archaeological features in Trenches 54, 76 and 113, where a NE-SW aligned ditch was identified. The remains of the ditch, where encountered, were relatively shallow. It is therefore possible that evidence of this ditch within Trenches 22, 30 and 94 has been truncated by ploughing, as the site is in use as an arable field. The aerial photos that were sourced for plotting the cropmarks on the site were dated 1972 and 1982 (MEX18160); it is conceivable that modern ploughing truncated parts of these features in the 30-40 years since the aerial photographs were taken.
- 5.1.3 The circular cropmark in the south-east corner of the site was encountered in the form of a ring-ditch in Trenches 121 and 122. Conversely, the smaller curvilinear cropmark to the north (in the area of Trench 88) and a half-circular cropmark to the west (in Trench 73) were not encountered.
- 5.1.4 The scatter of large discrete cropmarks did not match any archaeological features within the trenches; this continues the trend observed in previous land parcels where these cropmarks have, at most, been indicative of geological variations.

### 5.2 Interpretation

- 5.2.1 **Neolithic and early Bronze Age.** A small number of features containing fragments of pottery, flint and occasionally hazelnut shells were positively dated to the Neolithic period. The presence of at least two pits dating to the early Neolithic is significant and suggests that there was a human presence and use of this landscape contemporary with and overlooked by the causewayed enclosure to the north.
- 5.2.2 It is also notable that a number of other pits were recorded that included charred remains as the primary or main fill but failed to produce any dating evidence. It is entirely possible that these also date to the early prehistoric period. The pit arrangement recorded in Trench 36 may have particular significance if this proves to date to the early prehistoric period as this would suggest a hengiform-style monument in close proximity to the causewayed enclosure. This suggests a continued ritual use of the landscape over numerous generations.
- 5.2.3 The circular ditched feature recorded in Trenches 121 and 122 appears certain to be a ring-ditch rather than a later prehistoric feature such as a roundhouse. The cropmark is a continuous feature and the excavated ditch was well-defined suggesting that this lacks any entry point. The presence of a ring-ditch raises the possibility that a primary burial or satellite internments may be present in this area and reinforces the continued use of the site as ritual space.

- 5.2.4 **Late Bronze Age and Iron Age.** The evidence recovered for late Bronze Age and early Iron Age activity is scant, although that for middle Iron Age remains is slightly more promising. Nevertheless, the available finds suggest that the site itself was not a focal point of significant activity, possibly with the main focus of activity being restricted to the enclosures sited within the extant causewayed enclosure.
- 5.2.5 The L-shaped ditch recorded in Trenches 124 and 125 is the only exception indicating a localised area of activity in the middle Iron Age.
- 5.2.6 **Roman.** Romano-British activity within the site is limited to Trench 37 at the western edge of the site. This represents a continuation of more complex Roman remains encountered in the adjacent Land Parcel 3 (Hornsby Lane), yet suggests that the focal point for this activity lay further west and that it did not extent substantially into Land Parcel 4.
- 5.2.7 **Post-medieval.** Historic field boundaries marked on the OS 1st Edition map were encountered in Trenches 22, 23 and 24. Further field boundaries that form part of the post-medieval enclosure arrangement were encountered in Trenches 54, 61, 63, 71, 76 and 113. While these do not feature on the 1st Edition map, their alignments and arrangement are consistent with the depicted boundaries identifying these are part of the same field system.
- 5.2.8 The truncated remains of Seaborough Hall were recorded in Trenches 138 and 139. These correspond accurately with the locations of the main structures marked on the 1st Edition OS map. The majority of the building materials and artefacts encountered date to the 18th to 20th century providing little evidence for an earlier origin for this house. However, a single, poorly-defined, pit was excavated from which a consistently-dated assemblage of later medieval to early post-medieval material was recovered, including tile, pottery and a dress pin. This is tantalising evidence, although earlier medieval artefacts were conspicuous in their absence.
- 5.2.9 **Undated.** A number of features could not be conclusively dated owing to the scarcity of surviving dateable material. It is possible that many of the undated pits could be assigned the early prehistoric period given the significant focal point of the causewayed enclosure adjacent to the site boundary.
- 5.2.10 **Natural features.** A number of natural features, mostly resulting from root disturbance, were investigated as part of the evaluation; several of these produced flints and prehistoric pottery as well as charred plant material, demonstrating the use of tree throw holes and similar features as refuse dumps during the prehistoric period.

### 5.3 Evaluation objectives and results

- 5.3.1 This evaluation established the presence of archaeological remains and investigated their character by analysing artefacts and environmental evidence. The evaluation also ground-truthed the cropmark evidence as identified by the 2019 aerial survey (Place Services 2019) including investigations of the apparently blank areas where no cropmarks had been identified. Similar to other previously evaluated land parcels, the large discrete cropmarks only matched geological variations but were not identified as archaeological features.

- 5.3.2 The archaeological evaluation was conducted within the general research parameters and objectives defined by the revised East of England Research Framework (Medlycott 2011).
- 5.3.3 In terms of specific objectives, the evaluation found clear evidence of Neolithic activity within the site, in Trenches 19, 51 and 80. The date of the ring-ditch encountered in Trenches 121 and 122 remains unclear, although it is possible that it represents the ploughed-out remains of a Neolithic or early Bronze Age barrow.
- 5.3.4 The evaluation also established a low level of Bronze Age activity with three features located in the western part of the site (Trenches 37 and 80).
- 5.3.5 Limited evidence of Roman activity was encountered in Trench 37. This is directly linked to the more complex Romano-British remains in the adjacent Land Parcel 3, to the west.
- 5.3.6 The truncated wall lines and other associated features encountered in Trenches 138 and 139 are very likely the remains of Seaborough Hall as shown on the 1st Edition Ordnance Survey map.
- 5.3.7 Other post-medieval activity within the site is limited to the historic field boundaries.

# Appendix A Trench Tables

<b>Trench 1</b>							
General description				Orientation		N-S	
Trench devoid of archaeology. Consists of ploughsoil and subsoil overlying a single colluvial layer and natural geology of silty sand with gravels.				Length (m)		30	
				Width (m)		2	
				Avg. depth (m)		1	
Context No.	Type	Fill Of	Width (m)	Depth (m)	Description	Finds	Date
100	Layer			0.3	Ploughsoil. Mid grey silty sand		
101	Layer			0.4	Subsoil. Mid orange brown silty sand		
102	Layer			0.25	Colluvial Layer. Dark orange brown silty clay		
103	Layer				Natural. Mottled mid orange and mid yellow brown silty sand with gravels.		
<b>Trench 2</b>							
General description				Orientation		E-W	
Trench devoid of archaeology. Consists of ploughsoil and subsoil overlying a single colluvial layer and natural geology of clayey sand				Length (m)		30	
				Width (m)		2	
				Avg. depth (m)		1	
Context No.	Type	Fill Of	Width (m)	Depth (m)	Description	Finds	Date
200	Layer			0.3	Ploughsoil. Mid grey brown silty sand		
201	Layer			0.35	Subsoil. Mid orange brown silty sand		
202	Layer				Colluvial Layer. Dark orange brown silty clay.		
<b>Trench 3</b>							
General description				Orientation		NW-SE	
Trench devoid of archaeology. Consists of ploughsoil and subsoil overlying a single colluvial layer and natural geology of clayey sand.				Length (m)		30	
				Width (m)		2	
				Avg. depth (m)		1	
Context No.	Type	Fill Of	Width (m)	Depth (m)	Description	Finds	Date
300	Layer			0.28	Ploughsoil. Mid grey brown silty sand		
301	Layer			0.28	Subsoil. Mid orange brown silty sand		
302	Layer			0.3	Colluvial Layer. Dark orange brown silty clay		
303	Layer				Natural. Mottled mid orange and mid yellow brown silty sand with gravels		
<b>Trench 4</b>							
General description				Orientation		E-W	



Trench devoid of archaeology. Consists of ploughsoil and subsoil overlying natural geology of silty sand with gravels.				Length (m)		30	
				Width (m)		2	
				Avg. depth (m)		0.6	
Context No.	Type	Fill Of	Width (m)	Depth (m)	Description	Finds	Date
400	Layer			0.3	Ploughsoil. Mid grey brown silty sand	flint	
401	Layer			0.21	Subsoil. Mid orange brown silty sand		
402	Layer				Natural. Mottled yellow/reddish orange fine sand with patches of gravel		
<b>Trench 5</b>							
General description				Orientation		N-S	
Trench devoid of archaeology. Consists of ploughsoil and subsoil overlying a single colluvial layer and natural geology of silty sand with gravels.				Length (m)		30	
				Width (m)		2	
				Avg. depth (m)		1	
Context No.	Type	Fill Of	Width (m)	Depth (m)	Description	Finds	Date
500	Layer			0.32	Ploughsoil. Mid grey brown silty sand		
501	Layer			0.46	Subsoil. Mid orange brown silty sand		
502	Layer			0.2	Colluvial Layer. Dark orange brown silty clay		
503	Layer				Natural. Mottled mid orange and mid yellow brown silty sand with gravels		
<b>Trench 6</b>							
General description				Orientation		E-W	
Trench devoid of archaeology. Consists of ploughsoil and subsoil overlying natural geology of silty sand with gravels.				Length (m)		30	
				Width (m)		2	
				Avg. depth (m)		0.8	
Context No.	Type	Fill Of	Width (m)	Depth (m)	Description	Finds	Date
600	Layer			0.26	Ploughsoil. Mid grey brown silty sand		
601	Layer			0.52	Subsoil. Mid orange brown silty sand		
602	Layer				Natural. Mid orange brown silty sand with patches of mid yellow orange sandy gravel		
<b>Trench 7</b>							
General description				Orientation		N-S	
Trench devoid of archaeology. Consists of ploughsoil and subsoil overlying a single colluvial layer and natural geology of silty sand with gravels.				Length (m)		30	
				Width (m)		2	
				Avg. depth (m)		1	
Context No.	Type	Fill Of	Width (m)	Depth (m)	Description	Finds	Date

700	Layer			0.27	Ploughsoil. Mid grey brown silty sand	flint	
701	Layer			0.28	Subsoil. Mid orange brown silty sand		
702	Layer			0.31	Colluvial Layer. Dark orange brown silty clay		
703	Layer				Natural. Mottled mid orange and mid yellow brown silty sand with gravels		
<b>Trench 8</b>							
General description				Orientation		NE-SW	
Trench devoid of archaeology. Consists of ploughsoil and subsoil overlying a single colluvial layer and natural geology of silty sand				Length (m)		30	
				Width (m)		2	
				Avg. depth (m)		1	
Context No.	Type	Fill Of	Width (m)	Depth (m)	Description	Finds	Date
800	Layer			0.24	Ploughsoil. Mid grey brown silty sand		
801	Layer			0.29	Subsoil. Mid orange brown silty sand		
802	Layer			0.37	Colluvial Layer. Mid orange brown silty clay		
803	Layer				Natural. Mottled mid orange and mid yellow brown silty sand		
<b>Trench 9</b>							
General description				Orientation		N-S	
Trench devoid of archaeology. Consists of ploughsoil and subsoil overlying natural geology of sandy gravels.				Length (m)		30	
				Width (m)		2	
				Avg. depth (m)		0.5	
Context No.	Type	Fill Of	Width (m)	Depth (m)	Description	Finds	Date
900	Layer			0.3	Ploughsoil. Mid grey brown, silty clay		
901	Layer			0.2	Subsoil. Mid orange brown silty sand		
902	Layer				Natural. Mid brown orange sandy gravel		
<b>Trench 10</b>							
General description				Orientation		E-W	
Trench devoid of archaeology. Consists of ploughsoil and subsoil overlying natural geology of sandy gravels				Length (m)		30	
				Width (m)		2	
				Avg. depth (m)		0.38	
Context No.	Type	Fill Of	Width (m)	Depth (m)	Description	Finds	Date
1000	Layer			0.26	Ploughsoil. Mid grey brown clay silt		
1001	Layer			0.12	Subsoil. Mid orange brown silty sand		
1002	Layer				Natural. Mid brown orange sandy gravel		
1003	Void						

<b>Trench 11</b>							
General description				Orientation		N-S	
Trench revealed a ditch terminus. Consisted of ploughsoil overlaying subsoil and a natural geology of clayey sand with gravels.				Length (m)		30	
				Width (m)		2	
				Avg. depth (m)		0.42	
Context No.	Type	Fill Of	Width (m)	Depth (m)	Description	Finds	Date
1100	Layer			0.25	Ploughsoil. Mid brownish grey, clayey sand		
1101	Layer			0.18	Subsoil. Mid grey brown, clayey sand		
1102	Layer				Natural. Mid orangey brown, clayey sand		
1103	Cut		2	0.37	Ditch. Terminus		
1104	Fill	1103	2	0.37	Secondary Fill. Mid grey brown, silty sand.		
<b>Trench 12</b>							
General description				Orientation		E-W	
Trench revealed a single pit/tree throw. Trench consists of ploughsoil and subsoil overlying natural geology of sandy gravel				Length (m)		30	
				Width (m)		2	
				Avg. depth (m)		0.56	
Context No.	Type	Fill Of	Width (m)	Depth (m)	Description	Finds	Date
1200	Layer			0.32	Ploughsoil. Dark greyish brown, silty sand		
1201	Layer			0.57	Subsoil. Mid orangish brown, silty sand		
1202	Layer				Natural. Light orangish brown, sandy gravel		
1203	Cut		0.97	0.33	Tree Throw		
1204	Fill	1203	0.97	0.08	Primary Fill. Dark orangey grey friable silty sand		
1205	Fill	1203	0.91	0.25	Secondary Fill. Dark brownish grey smooth silt		
<b>Trench 13</b>							
General description				Orientation		N-S	
Trench devoid of archaeology. Trench consists of ploughsoil and subsoil overlying two colluvial layer. Natural not exposed				Length (m)		30	
				Width (m)			
				Avg. depth (m)		1	
Context No.	Type	Fill Of	Width (m)	Depth (m)	Description	Finds	Date
1300	Layer			0.32	Ploughsoil. Dark greyish brown, silty sand	flint	
1301	Layer			0.26	Subsoil. Mid greyish brown, silty sand		
1302	Layer			0.29	Colluvial Layer. Mid orangish brown, silty sand		
1303	Layer				Colluvial Layer. Mid yellowish brown, silty sand		
<b>Trench 14</b>							

General description				Orientation		E-W	
Trench devoid of archaeology. Consists of ploughsoil and subsoil overlying two colluvial layers and natural geology of clayey sand				Length (m)		30	
				Width (m)		2	
				Avg. depth (m)		1	
Context No.	Type	Fill Of	Width (m)	Depth (m)	Description	Finds	Date
1400	Layer			0.28	Ploughsoil. Dark grey brown, silty clay	flint	
1401	Layer			0.25	Subsoil. Mid brown, silty sand		
1402	Layer			0.2	Colluvial Layer. Light greyish yellow, silty sand. Only visible on E end of trench, covering colluvial 1403		
1403	Layer			0.27	Colluvial Layer. Light bluish grey, clayey sand. Only visible on E end of trench, covers colluvial 1404, covered by colluvial 1402		
1404	Layer			0.6	Colluvial Layer. Mid brownish yellow, silty sand. Only exposed on W end of trench, covered by subsoil 1402. Not visible on E end of trench, covered by colluvial 1403 (>1m deep)		

### Trench 15

General description				Orientation		NW-SE	
Trench revealed the remains of a possible trackway/hollow way. Consists of ploughsoil and subsoil overlying colluvial layer. Natural geology not exposed.				Length (m)		30	
				Width (m)		2	
				Avg. depth (m)		1	
Context No.	Type	Fill Of	Width (m)	Depth (m)	Description	Finds	Date
1500	Layer			0.31	Ploughsoil. Dark grey brown, silty clay		
1501	Layer			0.19	Subsoil. Mid brown, silty sand		
1502	Layer			0.5	Colluvial Layer. Mid yellow orange, silty sand		
1503	Cut		0.65	0.36	Ditch		
1504	Fill	1503	0.65	0.36	Secondary Fill. Greyish brown silty sand, friable		
1505	Cut		2.6	0.22	Ditch		
1506	Fill	1505	2.6	0.22	Tertiary Fill. Yellowish brown silty clay firm		
1507	Fill	1505	2.3	0.16	Primary Fill. Sand and gravel brownish grey very firm		

### Trench 16

General description				Orientation		E-W	
				Length (m)		30	
				Width (m)		2	

Trench devoid of archaeology. Consists of ploughsoil overlying natural geology of silty sand with occasional gravels				Avg. depth (m)		0.25	
Context No.	Type	Fill Of	Width (m)	Depth (m)	Description	Finds	Date
1600	Layer			0.25	Ploughsoil. Mid grey brown silty clay		
1601	Layer				Natural. Mid orange brown silty sand with occasional gravels		
<b>Trench 17</b>							
General description				Orientation		N-S	
Trench revealed one linear feature. Trench consisted of ploughsoil and subsoil overlying the natural geology of clayey sand with gravel patches.				Length (m)		30	
				Width (m)		2	
				Avg. depth (m)		0.44	
Context No.	Type	Fill Of	Width (m)	Depth (m)	Description	Finds	Date
1700	Layer			0.3	Ploughsoil. Dark grey brown, silty sand		
1701	Layer			0.14	Subsoil. Mid grey brown, silty sand		
1702	Layer				Natural. Mid orange brown, silty sand with patches of gravel.		
1703	Cut		1.41	0.23	Ditch		
1704	Fill	1703	0.65	0.11	Secondary Fill. Mid orange brown, silty sand		
1705	Fill	1703	1.11	0.2	Tertiary Fill. Mid grey, silty sand		
<b>Trench 18</b>							
General description				Orientation		E-W	
Trench devoid of archaeology. Consists ploughsoil and subsoil overlying natural geology of				Length (m)		30	
				Width (m)		2	
				Avg. depth (m)		0.4	
Context No.	Type	Fill Of	Width (m)	Depth (m)	Description	Finds	Date
1800	Layer			0.24	Ploughsoil. Mid grey brown. Silty clay.		
1801	Layer			0.4	Subsoil. Mid reddish brown. Clayey silt.		
1802	Layer				Natural. Mid yellowish grey Compact sandy gravel up to 100mm natural subangular and - rounded flint.		
1803	Layer		1.1	0.06	Natural. Natural infill in natural dip in gravel. Same as (1801) excavated to prove it is natural.		
<b>Trench 19</b>							
General description				Orientation		NW-SE	
				Length (m)		30	
				Width (m)		2	

Trench revealed one large pit. Consisted of ploughsoil overlaying subsoil and natural geology of clayey sand with gravels.					Avg. depth (m)		0.7	
Context No.	Type	Fill Of	Width (m)	Depth (m)	Description	Finds	Date	
1900	Layer			0.25	Ploughsoil. Mid brownish grey, clayey sand.			
1901	Layer			0.7	Subsoil. Mid grey brown, clayey sand.			
1902	Layer				Natural. Mid orangey brown, clayey sand with gravels.			
1903	Cut		3.46	0.56	Pit			
1904	Fill	1903	0.62	0.54	Tertiary Fill. Mid yellow brown sandy silt	pottery flint	ENeo	
1905	Fill	1903	0.7	0.56	Secondary Fill. Light yellow grey clay silt	pottery	ENeo	
1906	Fill	1903	0.56	0.54	Primary Fill. Mid orange brown silty sand	pottery flint	ENeo	
1907	Layer		11		Colluvial Layer. Mid brown orange, silty sand			
<b>Trench 20</b>								
General description					Orientation		E-W	
Trench devoid of archaeology. Trench consists of ploughsoil and subsoil overlying two colluvial layer. Natural not exposed					Length (m)		30	
					Width (m)		2	
					Avg. depth (m)		1	
Context No.	Type	Fill Of	Width (m)	Depth (m)	Description	Finds	Date	
2000	Layer			0.31	Ploughsoil. Dark greyish brown, silty sand			
2001	Layer			0.29	Subsoil. Mid greyish brown, silty sand			
2002	Layer			0.41	Colluvial Layer. Mid orangish brown, silty sand			
2003	Layer				Colluvial Layer. Mid yellowish brown, silty sand			
<b>Trench 21</b>								
General description					Orientation		N-S	
Trench devoid of archaeology. Consists of ploughsoil, subsoil and two colluvial layers. Natural geology not exposed.					Length (m)		30	
					Width (m)		2	
					Avg. depth (m)		1	
Context No.	Type	Fill Of	Width (m)	Depth (m)	Description	Finds	Date	
2100	Layer			0.32	Ploughsoil. Dark grey brown, silty clay			
2101	Layer			0.16	Subsoil. Mid brown, silty sand			
2102	Layer			0.18	Colluvial Layer. Light grey, silty sand			
2103	Layer			0.34	Colluvial Layer. Mid greyish yellow, silty sand. Thicker than 0.34m, but 1m max. depth in trench reached			

<b>Trench 22</b>							
General description				Orientation		E-W	
Trench revealed one hedgerow. Consists of ploughsoil and subsoil overlying colluvial layer and natural geology of clayey sand				Length (m)		30	
				Width (m)		2	
				Avg. depth (m)		1	
Context No.	Type	Fill Of	Width (m)	Depth (m)	Description	Finds	Date
2200	Layer			0.37	Ploughsoil. Dark grey brown, silty clay		
2201	Layer			0.2	Subsoil. Mid brown, silty sand		
2202	Layer			0.41	Colluvial Layer. Mid greyish orange, silty sand		
2203	Layer				Natural. Light bluish grey, clayey sand. Only exposed in the centre of the trench		
2204	Unexcavated feature		1.6		Ditch. Dark brownish grey, silty sand.		
<b>Trench 23</b>							
General description				Orientation		N-S	
Trench revealing NW-SE linear. Consists of ploughsoil and subsoil overlying three colluvial layers. Natural not exposed				Length (m)		30	
				Width (m)		2	
				Avg. depth (m)		1	
Context No.	Type	Fill Of	Width (m)	Depth (m)	Description	Finds	Date
2300	Layer			0.31	Ploughsoil. Dark grey brown, silty clay		
2301	Layer			0.25	Subsoil. Mid brown, silty sand		
2302	Layer			0.17	Colluvial Layer. Light greyish yellow, silty sand. Only appears on N end of trench, downhill, overlying colluvial 2303		
2303	Layer			0.38	Colluvial Layer. Mid grey orange, silty sand. Exposed in the whole trench, getting thicker towards N. Overlain by colluvial 2302		
2304	Layer				Colluvial Layer. Light bluish grey, clayey sand. Only exposed on S half of trench, going over 1m deep towards N		
2305	Cut		2.62	0.8	Modern. Hedgerow. Base not reached		
2306	Fill	2305	0.76	0.16	Primary Fill. Mid greyish brown, silty sand		
2307	Fill	2305	2.62	0.42	Deliberate Backfill. Dark brownish grey, black. Silty sand		
2308	Fill	2305	0.92	0.2	Deliberate Backfill. Dark greyish brown, clay sand		
<b>Trench 24</b>							
General description				Orientation		E-W	

Trench revealing linear ditch related to other possible discrete features. Consists of ploughsoil and subsoil overlying colluvial layer and natural geology of clayey sand					Length (m)		30	
					Width (m)		2	
					Avg. depth (m)		0.83	
Context No.	Type	Fill Of	Width (m)	Depth (m)	Description	Finds	Date	
2400	Layer			0.28	Ploughsoil. Dark grey brown, silty clay			
2401	Layer			0.22	Subsoil. Mid brown, silty sand			
2402	Layer			0.33	Colluvial Layer. Mid greyish orange, silty sand			
2403	Layer				Colluvial Layer. Light yellow/blue grey, clayey sand			
2404	Unexcavated feature		1.8		Modern. Field boundary visible on 19th century historic maps	CBM	18-19th C	
2405	Cut		4.38	0.62	Natural Feature. Probable root bowl/burrow cutting edge of 19th century boundary			
2406	Fill	2405	4.38	0.62	Other Fill. Mixed. Dark brown grey. With mid grey brown mottles, clay silt. Not excavated to base due to depth of trench	pottery	MIA	
2407	Fill	2405	2.7	0.28	Secondary Fill. Dark grey brown, friable clay silt. Only observed in section			

### Trench 25

General description					Orientation		N-S	
Trench revealed two intercutting pits. Consists of ploughsoil overlying natural geology of silty sand with gravels					Length (m)		30	
					Width (m)		2	
					Avg. depth (m)		0.3	
Context No.	Type	Fill Of	Width (m)	Depth (m)	Description	Finds	Date	
2500	Layer			0.3	Ploughsoil. Mid grey brown silty clay			
2501	Layer				Natural. Mid orange brown silty sand with gravels			
2502	Cut		0.58	0.2	Pit			
2503	Fill	2502	0.58	0.2	Secondary Fill. Mid to dark brownish grey, sandy silt			
2504	Cut		0.74	0.28	Pit			
2505	Fill	2504	0.74	0.28	Secondary Fill. Mid reddish brown, sandy silt			

### Trench 26

General description					Orientation		E-W	
Trench devoid of archaeology. Consists of ploughsoil overlying natural geology of silty sand with gravels					Length (m)		30	
					Width (m)		2	
					Avg. depth (m)		0.35	
Context No.	Type	Fill Of	Width (m)	Depth (m)	Description	Finds	Date	



2600	Layer			0.35	Ploughsoil. Dark greyish brown, silty sand		
2601	Layer				Natural. Mid orangish brown, silty sand		
<b>Trench 27</b>							
General description				Orientation		N-S	
Trench devoid of archaeology. Consists of ploughsoil and subsoil overlying two colluvial layers. Natural not reached at 1m depth.				Length (m)		30	
				Width (m)		2	
				Avg. depth (m)		0.9	
Context No.	Type	Fill Of	Width (m)	Depth (m)	Description	Finds	Date
2700	Layer			0.3	Ploughsoil. Mid grey brown clay silt		
2701	Layer			0.6	Subsoil. Mid orange brown silty sand		
2702	Layer			0.1	Colluvial Layer. Mid orange brown silty sand		
2703	Layer			0.02	Colluvial Layer. Mid orange brown sandy silt		
<b>Trench 28</b>							
General description				Orientation		W-E	
Trench devoid of archaeology. Consists of ploughsoil overlaying subsoil.				Length (m)		30	
				Width (m)		2	
				Avg. depth (m)		1	
Context No.	Type	Fill Of	Width (m)	Depth (m)	Description	Finds	Date
2800	Layer			0.28	Ploughsoil. Mid brownish grey, clayey sand		
2801	Layer			0.7	Subsoil. Mid grey brown, clayey sand.		
2802	Layer			0.02	Colluvial Layer. Mid grey brown sandy silt.		
2803	Unexcavated feature		1.57		Tree Throw. Dark grey brown firm silty clay.		
<b>Trench 29</b>							
General description				Orientation		N-S	
Trench revealed a possible pits/treethrow. Trench consists of topsoil and subsoil overlying two colluvial layer and natural geology of sandy gravel.				Length (m)		30	
				Width (m)		2	
				Avg. depth (m)		1	
Context No.	Type	Fill Of	Width (m)	Depth (m)	Description	Finds	Date
2900	Layer			0.31	Ploughsoil. Dark greyish brown, silty sand		
2901	Layer			0.27	Subsoil. Mid greyish brown, silty sand		
2902	Layer			0.21	Colluvial Layer. Mid yellowish grey, silty sand. Not present in northern half		
2903	Layer			0.23	Colluvial Layer. Mid orangish brown, silty sand		
2904	Layer				Natural. Mid yellowish brown, sandy gravel		

2905	Unexcavated feature		0.5		Tree Throw. Dark grey brown clay silt.		
<b>Trench 30</b>							
General description				Orientation		E-W	
Trench revealed one unexcavated possible pit or treehole. Trench consists of topsoil and subsoil overlying one colluvial layer. Natural not exposed				Length (m)		30	
				Width (m)		2	
				Avg. depth (m)		1	
Context No.	Type	Fill Of	Width (m)	Depth (m)	Description	Finds	Date
3000	Layer			0.31	Ploughsoil. Dark greyish brown, silty sand	flint	
3001	Layer			0.32	Subsoil. Mid greyish brown, silty sand		
3002	Layer				Colluvial Layer. Mid orangish brown, silty sand		
3003	Unexcavated feature		1.3		Tree Throw. Mid grey brown. Silty clay.		
<b>Trench 31</b>							
General description				Orientation		N-S	
Trench devoid of archaeology. Consists of ploughsoil, subsoil and two colluvial layers. Natural geology not exposed.				Length (m)		30	
				Width (m)		2	
				Avg. depth (m)		1	
Context No.	Type	Fill Of	Width (m)	Depth (m)	Description	Finds	Date
3100	Layer			0.32	Ploughsoil. Dark grey brown, silty clay		
3101	Layer			0.18	Subsoil. Mid brown, silty sand		
3102	Layer			0.16	Colluvial Layer. Light grey silty clay		
3103	Layer			0.34	Colluvial Layer. Light greyish yellow, silty sand. Thicker than 0.34m, but 1m max. depth reached		
<b>Trench 32</b>							
General description				Orientation		E-W	
Trench devoid of archaeology. Consists of ploughsoil, subsoil and colluvial layer. Natural geology not exposed.				Length (m)		30	
				Width (m)		2	
				Avg. depth (m)		1	
Context No.	Type	Fill Of	Width (m)	Depth (m)	Description	Finds	Date
3200	Layer			0.3	Ploughsoil. Dark grey brown, silty clay		
3201	Layer			0.17	Subsoil. Mid brown, silty sand		
3202	Layer			0.53	Colluvial Layer. Mid brownish yellow, silty sand. Thicker than 0.53m, but 1m max. depth in trench reached		
<b>Trench 33</b>							
General description				Orientation		N-S	

Trench devoid of archaeology. Consists of ploughsoil and subsoil overlying two colluvial layers. Natural geology not exposed.				Length (m)		30	
				Width (m)		2	
				Avg. depth (m)		1	
Context No.	Type	Fill Of	Width (m)	Depth (m)	Description	Finds	Date
3300	Layer			0.29	Ploughsoil. Dark grey brown, silty clay		
3301	Layer			0.2	Subsoil. Mid brown, silty sand		
3302	Layer			0.45	Colluvial Layer. Mid brownish orange, silty sand		
3303	Layer			0.06	Colluvial Layer. Light greyish yellow, silty clay. Only 0.06m exposed, as 1m max. depth in trench reached		
<b>Trench 34</b>							
General description				Orientation		E-W	
Trench devoid of archaeology. Consists of ploughsoil and subsoil overlying two colluvial layers. Natural geology not exposed.				Length (m)		30	
				Width (m)		2	
				Avg. depth (m)		1	
Context No.	Type	Fill Of	Width (m)	Depth (m)	Description	Finds	Date
3400	Layer			0.3	Ploughsoil. Dark grey brown, silty clay		
3401	Layer			0.19	Subsoil. Mid brown, silty sand		
3402	Layer			0.38	Colluvial Layer. Mid brownish orange, silty sand		
3403	Layer			0.13	Colluvial Layer. Light greyish yellow, silty sand. >0.13m, but 1m max. depth in trench reached		
<b>Trench 35</b>							
General description				Orientation		N-S	
Trench devoid of archaeology. Consists of ploughsoil and subsoil overlying colluvial layer and natural geology of clayey sand				Length (m)		30	
				Width (m)		2	
				Avg. depth (m)		1	
Context No.	Type	Fill Of	Width (m)	Depth (m)	Description	Finds	Date
3500	Layer			0.3	Ploughsoil. Dark grey brown, silty clay		
3501	Layer			0.25	Subsoil. Mid brown, silty sand		
3502	Layer			0.35	Colluvial Layer. Mid brown orange, silty sand		
3503	Layer				Colluvial Layer. Light yellow/blue grey, clayey sand		
<b>Trench 36</b>							
General description				Orientation		E-W	
				Length (m)		30	

Trench revealing several pits. Consists of ploughsoil and subsoil overlying colluvial layer and natural geology of silty clay.				Width (m)		2	
				Avg. depth (m)		0.8	
Context No.	Type	Fill Of	Width (m)	Depth (m)	Description	Finds	Date
3600	Layer			0.31	Ploughsoil. Dark grey brown, silty clay		
3601	Layer			0.19	Subsoil. Mid brown, silty sand		
3602	Layer			0.3	Colluvial Layer. Mid brown orange, silty sand	flint	
3603	Layer				Colluvial Layer. Light yellow/blue grey, clayey sand		
3604	Unexcavated feature		0.76		Pit. Light brown grey friable clay sand. Frequent charcoal inclusions.		
3605	Unexcavated feature		0.9		Pit. Light brown grey clay sand, charcoal inclusions		
3606	Cut		0.76	0.1	Pit. Possible oven, evidence of in situ burning.		
3607	Fill	3606	0.76	0.1	Secondary Fill. Light brown grey sandy clay with central deposit of charcoal and vitrified clay.	fired clay	
3608	Unexcavated feature		1.56	0.2	Pit. Mid brown grey silty clay w. Charcoal		
3609	Unexcavated feature		2.47	0.18	Pit. Light brown grey sandy clay. Charcoal inclusions		
3610	Layer				Natural. Light orangey brown, silty clay		

### Trench 37

General description				Orientation		E-W	
Trench revealed a gully and two intercutting ditches. Consists of ploughsoil overlying natural geology of silty sand with occasional gravels				Length (m)		30	
				Width (m)		2	
				Avg. depth (m)		0.3	
Context No.	Type	Fill Of	Width (m)	Depth (m)	Description	Finds	Date
3700	Layer			0.3	Ploughsoil. Mid grey brown silty clay		
3701	Layer				Natural. Mid orange brown silty sand with occasional gravels		
3702	Cut		0.58	0.12	Ditch		
3703	Fill	3702	0.58	0.12	Fill. Mid orange brown, sandy silt	Pottery	LBA/IA
3704	Cut		1.59	0.14	Ditch		
3705	Fill	3704	1.59	0.14	Fill. Mid orange brown, sandy silt		
3706	Cut		2.37	0.31	Ditch		
3707	Fill	3706	2.37	0.31	Fill. Mid orange brown, sandy silt	pottery flint	LIA-ERom

### Trench 38

General description				Orientation		N-S	
				Length (m)		30	

Trench devoid of archaeology. Consists of ploughsoil overlying natural geology of silty sand with gravels.				Width (m)		3	
				Avg. depth (m)		0.8	
Context No.	Type	Fill Of	Width (m)	Depth (m)	Description	Finds	Date
3800	Layer			0.35	Ploughsoil. Mid grey brown silty clay		
3801	Layer			0.45	Subsoil. Mid orange brown silty sand		
3802	Layer				Natural. Mid yellow brown silty sand		

### Trench 39

General description				Orientation		E-W	
Trench revealed three intercutting pits. Consists of ploughsoil and subsoil overlying natural geology of silty sand and gravels				Length (m)		30	
				Width (m)		2	
				Avg. depth (m)		0.8	
Context No.	Type	Fill Of	Width (m)	Depth (m)	Description	Finds	Date
3900	Layer			0.35	Ploughsoil. Dark grey brown, silty clay	flint	
3901	Layer			0.45	Subsoil. Mid orangey brown, silty sand		
3902	Layer				Natural. Light yellowish brown, silty sand		
3903	Cut		0.18	0.23	Pit. 0.44m wide		
3904	Fill	3903	0.18	0.23	Secondary Fill. mid to dark brownish grey, sandy silt		
3905	Cut		1.22	0.32	Pit. 0.91m wide		
3906	Fill	3905	1.22	0.32	Secondary Fill. mid to dark brownish grey, sandy silt		
3907	Cut		0.62	0.21	Pit. 0.55m wide		
3908	Fill	3907	0.62	0.21	Secondary Fill. light to mid greyish brown		

### Trench 40

General description				Orientation		N-S	
Trench devoid of archaeology. Ploughsoil, subsoil and colluvial layers overlying natural geology of silty sand with gravels.				Length (m)		30	
				Width (m)		2	
				Avg. depth (m)		0.75	
Context No.	Type	Fill Of	Width (m)	Depth (m)	Description	Finds	Date
4000	Layer			0.32	Ploughsoil. Dark grey brown, silty clay		
4001	Layer			0.25	Subsoil. Mid orangey brown, silty sand		
4002	Layer			0.18	Colluvial Layer. Light yellowish brown, silty sand. Only visible on N end of trench		
4003	Layer				Natural. Mid red brown, silty sand with gravels		

### Trench 41

General description				Orientation		E-W	
---------------------	--	--	--	-------------	--	-----	--

Trench devoid of archaeology. Ploughsoil and subsoil layers overlying natural geology of silty sand with gravels.				Length (m)		30	
				Width (m)		2	
				Avg. depth (m)		0.52	
Context No.	Type	Fill Of	Width (m)	Depth (m)	Description	Finds	Date
4100	Layer			0.32	Ploughsoil. Dark grey brown, silty clay		
4101	Layer			0.2	Subsoil. Mid orangey brown, silty sand. Mostly visible on W end of trench		
4102	Layer				Natural. Mid red brown, silty sand with gravels		

#### Trench 42

General description				Orientation		N-S	
Trench devoid of archaeology. Consists of ploughsoil and subsoil overlying natural geology of silty sand and gravels.				Length (m)		30	
				Width (m)		2	
				Avg. depth (m)		0.7	
Context No.	Type	Fill Of	Width (m)	Depth (m)	Description	Finds	Date
4200	Layer			0.3	Ploughsoil. Dark grey brown, silty clay		
4201	Layer			0.4	Subsoil. Mid brown, silty sand. Barely present on S end of trench, getting thicker towards N, downhill		
4202	Layer				Natural. Mid red yellow, silty sand and gravels. Natural geology going deeper towards N, downhill		

#### Trench 43

General description				Orientation		E-W	
Trench devoid of archaeology. Consists of ploughsoil, subsoil and colluvial layers are overlying natural geology of silty sand and gravels.				Length (m)		30	
				Width (m)		2	
				Avg. depth (m)		1	
Context No.	Type	Fill Of	Width (m)	Depth (m)	Description	Finds	Date
4300	Layer			0.3	Ploughsoil. Dark grey brown, silty clay		
4301	Layer			0.38	Subsoil. Mid brown, silty sand		
4302	Layer			0.32	Colluvial Layer. Light grey brown, silty sand. Thicker than 0.32m in some places, but going over 1m max. depth in trench		
4303	Layer				Natural. Mid red yellow, silty sand and gravels. Natural only visible on both ends of trench and in the middle		

#### Trench 44

General description				Orientation		N-S	
---------------------	--	--	--	-------------	--	-----	--

Trench devoid of archaeology. Consists of ploughsoil, subsoil and colluvial layers are overlying natural geology of silty sand and gravels.				Length (m)		30	
				Width (m)		2	
				Avg. depth (m)		1	
Context No.	Type	Fill Of	Width (m)	Depth (m)	Description	Finds	Date
4400	Layer			0.3	Ploughsoil. Dark grey brown, silty clay		
4401	Layer			0.41	Subsoil. Mid orangey brown, silty sand		
4402	Layer			0.29	Colluvial Layer. Light grey yellow, silty sand. Thicker than 0.29m, but 1m max. depth in trench reached		
4403	Layer				Natural. Mid brown, silty sand and gravels. Barely visible, only reached on N end of trench		

#### Trench 45

General description				Orientation		E-W	
Trench devoid of archaeology. Consists of ploughsoil, subsoil and two colluvial layers overlying natural geology of silty sand and gravels.				Length (m)		30	
				Width (m)		2	
				Avg. depth (m)		1	
Context No.	Type	Fill Of	Width (m)	Depth (m)	Description	Finds	Date
4500	Layer			0.3	Ploughsoil. Dark grey brown, silty clay		
4501	Layer			0.21	Subsoil. Mid grey brown, silty sand		
4502	Layer			0.33	Colluvial Layer. Light grey orange, silty sand		
4503	Layer			0.13	Colluvial Layer. Light grey yellow, silty sand. Layer thicker than 0.13m but goes over 1m deep.		
4504	Layer				Natural. Mid red/yellow brown, silty sand and gravels. Only reached and visible on both sides of the trench		

#### Trench 46

General description				Orientation		NE-SW	
Trench devoid of archeology. Trench consists of ploughsoil and subsoil overlying one colluvial layer and natural geology of sandy gravel				Length (m)		30	
				Width (m)		2	
				Avg. depth (m)		0.95	
Context No.	Type	Fill Of	Width (m)	Depth (m)	Description	Finds	Date
4600	Layer			0.3	Ploughsoil. Dark greyish brown, silty sand		
4601	Layer			0.28	Subsoil. Mid greyish brown, silty sand		
4602	Layer			0.31	Colluvial Layer. Mid orangish brown, silty sand		
4603	Layer				Natural. Mid orangish brown, sandy gravel		

#### Trench 47

General description				Orientation		E-W	
Trench revealed one ditch. Trench consists of ploughsoil and subsoil overlying one colluvial layer. Natural not exposed				Length (m)		30	
				Width (m)		2	
				Avg. depth (m)		1	
Context No.	Type	Fill Of	Width (m)	Depth (m)	Description	Finds	Date
4700	Layer			0.31	Ploughsoil. Dark greyish brown, silty sand		
4701	Layer			0.32	Subsoil. Mid greyish brown, silty sand		
4702	Layer				Colluvial Layer. Mid yellowish brown, silty sand		
4703	Fill	4704	1	0.82	Deliberate Backfill. Mid grey brown clay silt	flint	
4704	Cut		1	0.82	Ditch. Modern feature observed cutting the subsoil layer		
<b>Trench 48</b>							
General description				Orientation		NE-SW	
Trench devoid of archeology. Trench consists of ploughsoil and subsoil overlying two colluvial layer. Natural not exposed				Length (m)		30	
				Width (m)		2	
				Avg. depth (m)		1	
Context No.	Type	Fill Of	Width (m)	Depth (m)	Description	Finds	Date
4800	Layer			0.31	Ploughsoil. Dark greyish brown, silty sand		
4801	Layer			0.28	Subsoil. Mid greyish brown, silty sand		
4802	Layer			0.32	Colluvial Layer. Mid orangish brown, silty sand		
4803	Layer				Colluvial Layer. Mid yellowish brown, silty sand		
<b>Trench 49</b>							
General description				Orientation		N-S	
Trench revealed one linear feature. Ploughsoil and subsoil overlying natural geology of clayey sand with gravels.				Length (m)		30	
				Width (m)		2	
				Avg. depth (m)		0.32	
Context No.	Type	Fill Of	Width (m)	Depth (m)	Description	Finds	Date
4900	Layer			0.32	Ploughsoil. Dark grey brown, silty clay		
4901	Layer			0.35	Subsoil. Mid orangey brown, clayey sand		
4902	Layer				Natural. Mid orangey brown, clayey sand with gravels		
4903	Cut		1.06	0.4	Ditch		
4904	Fill	4903	106	0.4	Secondary Fill. Mid orange brown, sandy silt		
<b>Trench 50</b>							
General description				Orientation		E-W	



Trench devoid of archaeology. consists of ploughsoil overlying natural geology of silty sand with gravels.				Length (m)		30	
				Width (m)		2	
				Avg. depth (m)		0.35	
Context No.	Type	Fill Of	Width (m)	Depth (m)	Description	Finds	Date
5000	Layer			0.35	Ploughsoil. Dark grey brown, silty clay		
5001	Layer				Natural. Mid red brown, silty sand with gravels		
<b>Trench 51</b>							
General description				Orientation		N-S	
Trench revealing two pits and a ditch. Ploughsoil and subsoil layers overlying natural geology of silty sand.				Length (m)		30	
				Width (m)		2	
				Avg. depth (m)		0.52	
Context No.	Type	Fill Of	Width (m)	Depth (m)	Description	Finds	Date
5100	Layer			0.28	Ploughsoil. Dark grey brown, silty clay		
5101	Layer			0.25	Subsoil. Mid orangey brown, silty sand		
5102	Layer				Natural. Mid red brown, silty sand		
5103	Cut		0.55	0.1	Pit		
5104	Fill	5103	0.55	0.1	Deliberate Backfill. Dark grey brown silty sand	pottery flint	ENeo
5105	Cut		0.46	0.38	Pit		
5106	Fill	5105	0.46	0.38	Primary Fill. Mid grey brown, sandy silt		
5107	Cut		0.74	0.14	Ditch		
5108	Fill	5107	0.74	0.14	Primary Fill. Mid orange brown silty sand		
<b>Trench 52</b>							
General description				Orientation		E-W	
Trench revealing two small discrete features. Ploughsoil and subsoil layers overlying natural geology of silty sand with gravels.				Length (m)		30	
				Width (m)		2	
				Avg. depth (m)		0.5	
Context No.	Type	Fill Of	Width (m)	Depth (m)	Description	Finds	Date
5200	Layer			0.3	Ploughsoil. Dark grey brown, silty clay	flint	
5201	Layer			0.2	Subsoil. Mid orangey brown, silty sand		
5202	Layer				Natural. Mid red brown, silty sand with gravels		
5203	Cut		0.4	0.08	Pit		
5204	Fill	5203	0.4	0.08	Primary Fill. Mid grey brown silty sand		
5205	Cut		0.97	0.48	Pit		
5206	Fill	5205	0.97	0.48	Primary Fill. Mid grey brown silty sand	flint	
<b>Trench 53</b>							

General description				Orientation		N-S	
Trench devoid of archaeology. Ploughsoil and subsoil layers overlying natural geology of silty sand with gravels.				Length (m)		30	
				Width (m)		2	
				Avg. depth (m)		0.48	
Context No.	Type	Fill Of	Width (m)	Depth (m)	Description	Finds	Date
5300	Layer			0.32	Ploughsoil. Dark grey brown, silty clay		
5301	Layer			0.16	Subsoil. Mid orangey brown, silty sand		
5302	Layer				Natural. Mid red brown, silty sand with gravels		
<b>Trench 54</b>							
General description				Orientation		E-W	
Trench revealed two ditches, one of which may be the remains of a possible hollow way. Consisted of ploughsoil and subsoil overlying natural geology of sand and gravel				Length (m)		30	
				Width (m)		2	
				Avg. depth (m)		0.58	
Context No.	Type	Fill Of	Width (m)	Depth (m)	Description	Finds	Date
5400	Layer			0.31	Ploughsoil. Mid brown grey sand silt		
5401	Layer			0.27	Subsoil. Mid grey brown silt sand		
5402	Layer				Natural. Mid yellow brown sand and gravel		
5403	Cut		0.82	0.32	Ditch		
5404	Fill	5403	0.82	0.32	Fill. Mid brown grey friable sandy silt		
5405	Cut		4.52	0.32	Ditch		
5406	Fill	5405	4.52	0.32	Fill. Mid brown grey friable sandy silt with occasional small sub-rounded and rounded stone inclusions and rare charcoal flecks.		
<b>Trench 55</b>							
General description				Orientation		N-S	
Trench devoid of archaeology. Consists of ploughsoil and subsoil covering the natural geology of sandy gravel				Length (m)		30	
				Width (m)		2	
				Avg. depth (m)		0.55	
Context No.	Type	Fill Of	Width (m)	Depth (m)	Description	Finds	Date
5500	Layer			0.25	Ploughsoil. Mid grey brown clay silt		
5501	Layer			0.3	Subsoil. Mid orange brown clay silt		
5502	Layer				Natural. Mid brown orange sandy gravel.		
<b>Trench 56</b>							
General description				Orientation		E-W	
				Length (m)		30	
				Width (m)		2	

Trench devoid of archaeology. Consists of ploughsoil and subsoil overlying natural geology of silty sand and gravels.				Avg. depth (m)		0.78	
Context No.	Type	Fill Of	Width (m)	Depth (m)	Description	Finds	Date
5600	Layer			0.28	Ploughsoil. Dark grey brown, silty clay		
5601	Layer			0.5	Subsoil. Mid orangey brown, silty sand		
5602	Layer				Natural. Mid yellowish brown, silty sand and gravels		

#### Trench 57

General description				Orientation		N-S	
Trench devoid of archaeology. Consists of ploughsoil, subsoil and colluvial overlying natural geology of silty sand and gravels.				Length (m)		30	
				Width (m)		2	
				Avg. depth (m)		0.77	
Context No.	Type	Fill Of	Width (m)	Depth (m)	Description	Finds	Date
5700	Layer			0.35	Ploughsoil. Dark grey brown, silty clay		
5701	Layer			0.28	Subsoil. Mid grey brown, silty sand		
5702	Layer			0.14	Colluvial Layer. Light grey yellow, silty sand		
5703	Layer				Natural. Mid red brown, silty sand and gravels		

#### Trench 58

General description				Orientation		E-W	
Trench revealed a single pit. Consists of ploughsoil, subsoil and colluvial overlying natural geology of silty sand and gravels.				Length (m)		30	
				Width (m)		2	
				Avg. depth (m)		0.8	
Context No.	Type	Fill Of	Width (m)	Depth (m)	Description	Finds	Date
5800	Layer			0.33	Ploughsoil. Dark grey brown, silty clay		
5801	Layer			0.26	Subsoil. Mid orangey brown, silty sand		
5802	Layer			0.41	Colluvial Layer. Light greyish yellow, silty sand		
5803	Layer				Natural. Mid red brown, silty sand and gravels		
5804	Cut		0.81	0.16	Pit. 0.56m wide		
5805	Fill	5804	0.81	0.16	Secondary Fill. mid to dark brownish grey slight orangey, clay silt		

#### Trench 59

General description				Orientation		NE-SW	
Trench devoid of archaeology. Trench consists of topsoil and subsoil overlying one colluvial layer and natural geology of sandy gravel				Length (m)		30	
				Width (m)		2	
				Avg. depth (m)		1	
Context No.	Type	Fill Of	Width (m)	Depth (m)	Description	Finds	Date

5900	Layer			0.32	Ploughsoil. Dark greyish brown, silty sand		
5901	Layer			0.31	Subsoil. Mid greyish brown, silty sand		
5902	Layer			0.41	Colluvial Layer. Mid yellowish brown sandy silt		
5903	Layer				Natural. Mid orangish brown, sandy gravel		
<b>Trench 60</b>							
General description				Orientation		E-W	
Trench devoid of archaeology. Consists of ploughsoil overlying natural geology of silty sand with gravels.				Length (m)		30	
				Width (m)		2	
				Avg. depth (m)		0.32	
Context No.	Type	Fill Of	Width (m)	Depth (m)	Description	Finds	Date
6000	Layer			0.32	Ploughsoil. Dark grey brown, silty clay		
6001	Layer				Natural. Mid red brown, silty sand with gravels		
<b>Trench 61</b>							
General description				Orientation		N-S	
Trench revealing one ditch. Ploughsoil and subsoil layers overlying natural geology of silty sand with gravels.				Length (m)		30	
				Width (m)		2	
				Avg. depth (m)		0.61	
Context No.	Type	Fill Of	Width (m)	Depth (m)	Description	Finds	Date
6100	Layer			0.31	Ploughsoil. Dark grey brown, silty clay		
6101	Layer			0.3	Subsoil. Mid brown, silty sand		
6102	Layer				Natural. Mid red brown, silty sand with gravels		
6103	Cut		0.68	0.14	Ditch		
6104	Fill	6103	0.68	0.14	Secondary Fill. Mid orangey brown, sandy silt		
<b>Trench 62</b>							
General description				Orientation		E-W	
Trench revealed three ditches, a terminus, a gully, and a pit. Ploughsoil and subsoil overlying natural geology of silty sand with gravels.				Length (m)		30	
				Width (m)		2	
				Avg. depth (m)		0.59	
Context No.	Type	Fill Of	Width (m)	Depth (m)	Description	Finds	Date
6200	Layer			0.31	Ploughsoil. Dark grey brown, silty clay	flint	
6201	Layer			0.28	Subsoil. Mid brown, silty sand		
6202	Layer				Natural. Mid red brown, silty sand with gravels		
6203	Cut		1.41	0.37	Ditch		
6204	Fill	6203	1.19	0.18	Primary Fill. Mid orange brown, silty sand	flint	
6205	Fill	6203	1.41	0.17	Primary Fill. Mid grey brown, silty sand		

6206	Cut		2.03	0.17	Ditch		
6207	Fill	6206	1.96	0.11	Secondary Fill. Mid brown, silty sand		
6208	Fill	6206	2.03	0.09	Tertiary Fill. Light orange brown, silty sand		
6209	Cut		0.48	0.24	Pit		
6210	Fill	6209	0.48	0.24	Primary Fill. Mid brown, silty sand		
6211	Cut		0.29	0.07	Ditch. Terminus		
6212	Fill	6211	0.29	0.07	Secondary Fill. Mid grey brown, silty sand		
6213	Cut		0.37	0.14	Ditch		
6214	Fill	6213	0.37	0.14	Secondary Fill. Mid orange brown, silty sand	flint	
6215	Cut		1.07	0.16	Ditch		
6216	Fill	6215	1.07	0.16	Secondary Fill. Mid grey, silty sand		

### Trench 63

General description				Orientation		N-S	
Trench revealing one ditch. Ploughsoil and subsoil layers overlying natural geology of silty sand with gravel patches.				Length (m)		30	
				Width (m)		2	
				Avg. depth (m)		0.5	
Context No.	Type	Fill Of	Width (m)	Depth (m)	Description	Finds	Date
6300	Layer			0.3	Ploughsoil. Dark grey brown, silty clay		
6301	Layer			0.2	Subsoil. Mid orangey brown, silty sand		
6302	Layer				Natural. Mid red brown, silty sand with gravel patches		
6303	Cut		1.02	0.36	Ditch		
6304	Fill	6303	1.02	0.36	Secondary Fill. Mid orangey brown, sandy silt/gravel		

### Trench 64

General description				Orientation		E-W	
Trench devoid of archaeology. Consists of ploughsoil and subsoil overlying natural geology of silty sand with gravels				Length (m)		30	
				Width (m)		2	
				Avg. depth (m)		0.6	
Context No.	Type	Fill Of	Width (m)	Depth (m)	Description	Finds	Date
6400	Layer			0.25	Ploughsoil. Dark grey brown, silty clay		
6401	Layer			0.31	Subsoil. Mid orangey brown, silty sand		
6402	Layer				Natural. Mid red brown, silty sand with gravel patches		
6403	Layer			0.06	Other Layer. Subsoil filling natural undulation. Same as (6001). Partially excavated to prove not a feature, not recorded.		

<b>Trench 65</b>							
General description				Orientation		N-S	
Trench revealed one natural feature. Consists of ploughsoil and subsoil overlying natural geology of silty sand and gravels				Length (m)		30	
				Width (m)		2	
				Avg. depth (m)		0.55	
Context No.	Type	Fill Of	Width (m)	Depth (m)	Description	Finds	Date
6500	Layer			0.29	Ploughsoil. dark grey brown silty clay		
6501	Layer			0.29	Subsoil. mid brown, silty sand		
6502	Layer				Natural. mid yellow red, silty sand and gravels		
6503	Cut		0.71	0.17	Natural Feature. 1.14m length		
6504	Fill	6503	0.71	0.17	Secondary Fill. mid to dark brownish grey		
<b>Trench 66</b>							
General description				Orientation		E-W	
Trench revealed a single tree throw. Consists of ploughsoil and subsoil overlying natural geology of silty sand with gravels				Length (m)		30	
				Width (m)		2	
				Avg. depth (m)		0.6	
Context No.	Type	Fill Of	Width (m)	Depth (m)	Description	Finds	Date
6600	Layer			0.27	Ploughsoil. Mid brown grey, clayey silt		
6601	Layer			0.2	Subsoil. Mid reddish brown, clay silt		
6602	Layer				Natural. Mid reddish brown clay silt with sand, and concentrations of rounded gravels		
6603	Cut		1.3	0.4	Tree Throw. Large tree throw with concentrated area of burning in the top of the fill		
6604	Fill	6603	1.3	0.4	Mid greyish brown, clay silt. With lenses of charcoal in the upper part of the fill	pottery	19thC
<b>Trench 67</b>							
General description				Orientation		N-S	
Trench revealed a single three throw. Consists of ploughsoil and subsoil overlying natural geology of silty sand and gravels.				Length (m)		30	
				Width (m)		2	
				Avg. depth (m)		0.52	
Context No.	Type	Fill Of	Width (m)	Depth (m)	Description	Finds	Date
6700	Layer			0.32	Ploughsoil. Dark grey brown, silty clay		
6701	Layer			0.2	Subsoil. Mid orangey brown, silty sand		
6702	Layer				Natural. Mid red brown, silty sand and gravels		
6703	Cut		1.2	0.39	Tree Throw. Irregularly ovoid shape in plan, undulating base and one		

					steep, one shallow concave side.		
6704	Fill	6703	1.2	0.39	Secondary Fill. Mixed fill, mid greyish brown with light yellowish grey mottles, clay silt		
<b>Trench 68</b>							
General description				Orientation		E-W	
Trench devoid of archaeology. Consists of ploughsoil and subsoil overlying natural geology of silty sand and gravels.				Length (m)		30	
				Width (m)		2	
				Avg. depth (m)		0.55	
Context No.	Type	Fill Of	Width (m)	Depth (m)	Description	Finds	Date
6800	Layer			0.32	Ploughsoil. Dark grey brown, silty clay		
6801	Layer			0.23	Subsoil. Mid orangey brown, silty sand		
6802	Layer				Natural. Mid red brown, silty and gravels		
<b>Trench 69</b>							
General description				Orientation		N-S	
Trench devoid of archaeology. Consists of ploughsoil and subsoil overlying natural geology of silty sand with gravels.				Length (m)		30	
				Width (m)		2	
				Avg. depth (m)		0.9	
Context No.	Type	Fill Of	Width (m)	Depth (m)	Description	Finds	Date
6900	Layer			0.3	Ploughsoil. Dark grey brown, silty clay		
6901	Layer			0.35	Subsoil. Mid orangey brown, silty sand. Getting clearly thicker towards N, downhill.		
6902	Layer			0.31	Colluvial Layer. Light greyish yellow, silty sand. Visible on N half side of trench, getting thicker towards N, downhill		
6903	Layer				Natural. Mid red/yellow brown, silty sand with gravels		
<b>Trench 70</b>							
General description				Orientation		NE-SW	
Trench revealing natural feature. Consists of ploughsoil, subsoil and colluvial overlying natural geology of silty sand and gravels.				Length (m)		30	
				Width (m)		2	
				Avg. depth (m)		0.72	
Context No.	Type	Fill Of	Width (m)	Depth (m)	Description	Finds	Date
7000	Layer			0.4	Ploughsoil. Dark grey brown, silty clay		
7001	Layer			0.12	Subsoil. Mid orangey brown, silty sand		
7002	Layer			0.2	Colluvial Layer. Light greyish yellow, silty sand.		

					Getting thicker towards N, downhill		
7003	Layer				Natural. Mid red/yellow brown, silty sand and gravels		
7004	Cut		0.9	0.1	Tree Throw. Shallow concave sides with undulating base partially observed in NW facing trench edge		
7005	Fill	7004	0.9	0.1	Secondary Fill. Friable mid brownish grey sandy silt. Observed cutting the colluvium. No finds recovered		

### Trench 71

General description				Orientation		NE-SW	
Five burnt features recorded. Trench consists of topsoil and subsoil overlying natural geology of sandy gravel				Length (m)		30	
				Width (m)		2	
				Avg. depth (m)		0.62	
Context No.	Type	Fill Of	Width (m)	Depth (m)	Description	Finds	Date
7100	Layer			0.3	Ploughsoil. Dark greyish brown, silty sand		
7101	Layer			0.31	Subsoil. Mid greyish brown, silty sand		
7102	Layer				Natural. Mid orangish brown, sandy gravel		
7103	Unexcavated feature		1.16		Pit. bright reddish orange, sandy silt		
7104	Unexcavated feature		0.6		Pit. mid to dark greyish brown, sandy silt, 2.02m length		
7105	Unexcavated feature		0.34		Pit. bright reddish orange, sandy silt, 0.71m length		
7106	Unexcavated feature		0.38		Pit. mid greyish brown slight orangey, sandy silt, 0.61m length		
7107	Unexcavated feature		0.26		Pit. light yellowish grey, sandy silt, 0.46m length		

### Trench 72

General description				Orientation		E-W	
Trench revealed two intercutting pits and a third lone pit. Ploughsoil and subsoil overlying natural geology of clayey sand with gravels.				Length (m)		30	
				Width (m)		2	
				Avg. depth (m)		0.32	
Context No.	Type	Fill Of	Width (m)	Depth (m)	Description	Finds	Date
7200	Layer			0.32	Ploughsoil. Dark grey brown, silty clay		
7201	Layer			0.25	Subsoil. Mid red brown, silty sand		
7202	Layer				Natural. Mid orangey brown, clayey sand with gravels		
7203	Cut		1.71	0.52	Pit. 1.45m wide		
7204	Fill	7203	1.71	0.37	Secondary Fill. mid brownish grey, sandy silt		



7205	Fill	7203	1.71	0.15	Secondary Fill. mid to dark grey, sandy silt		
7206	Cut		0.22	0.38	Pit. 0.67m wide		
7207	Fill	7206	0.22	0.38	Secondary Fill. mid greyish brown, sandy silt		
7208	Fill	7209	1.78	0.14	Primary Fill. mid greyish brown slight yellowish, sandy silt		
7209	Cut		1.78	0.33	Pit		
7210	Fill	7209	1.78	0.19	Secondary Fill. mid to dark brownish grey, sandy silt		

### Trench 73

General description				Orientation		SW-NE	
Trench revealed single ditch and some silty patches. Trench consists of topsoil and subsoil overlying natural geology of sandy gravel				Length (m)		30	
				Width (m)		2	
				Avg. depth (m)		0.52	
Context No.	Type	Fill Of	Width (m)	Depth (m)	Description	Finds	Date
7300	Layer			0.31	Ploughsoil. Dark greyish brown, silty sand		
7301	Layer			0.21	Subsoil. Mid greyish brown, silty sand		
7302	Layer				Natural. Mid orangish brown, sandy gravel		
7303	Cut		0.63	0.37	Ditch		
7304	Fill	7303	0.63	0.37	Deliberate Backfill. Mid brown grey, clayey silt, inclusions of rounded gravel		

### Trench 74

General description				Orientation		E-W	
Trench revealed one natural feature. Trench consists of topsoil and subsoil overlying natural geology of sandy gravel				Length (m)		30	
				Width (m)		2	
				Avg. depth (m)		0.55	
Context No.	Type	Fill Of	Width (m)	Depth (m)	Description	Finds	Date
7400	Layer			0.31	Ploughsoil. Dark greyish brown, silty sand	flint	
7401	Layer			0.22	Subsoil. Mid greyish brown, silty sand		
7402	Layer				Natural. Mid orangish brown, sandy gravel		
7403	Cut		1.55	0.6	Natural Feature		
7404	Fill	7403	1.55	0.6	Other Fill. Mid greyish brown silty sand. Infill of dip in natural gravel. Same as (7401).		

### Trench 75

General description				Orientation		E-W	
				Length (m)		30	
				Width (m)		2	

Trench devoid of archaeology. Consists of ploughsoil and subsoil overlying natural geology of silty sand with gravels				Avg. depth (m)		0.4	
Context No.	Type	Fill Of	Width (m)	Depth (m)	Description	Finds	Date
7500	Layer			0.3	Ploughsoil. Mid grey brown silty clay	flint	
7501	Layer			0.1	Subsoil. Mid orange brown silty sand		
7502	Layer				Natural. Mid orange brown silty sand with gravels		
<b>Trench 76</b>							
General description				Orientation		NE-SW	
Trench revealed two linear features. Consists of ploughsoil and subsoil overlying natural geology of silty sand and gravels				Length (m)		30	
				Width (m)		2	
				Avg. depth (m)		0.5	
Context No.	Type	Fill Of	Width (m)	Depth (m)	Description	Finds	Date
7600	Layer			0.29	Ploughsoil. dark brownish grey, sandy silt		
7601	Layer			0.16	Subsoil. mid to dark brown, sandy silt		
7602	Layer				Natural. light to mid yellowish brown, silty sand and gravels		
7603	Cut		0.8	0.2	Ditch		
7604	Fill	7603	0.8	0.2	Secondary Fill. mid to dark greyish brown, sandy silt		
7605	Cut		0.92	0.34	Ditch		
7606	Fill	7605	0.92	0.34	Fill. mid greyish brown, sandy silt	CBM	18th-19thC
<b>Trench 77</b>							
General description				Orientation		N-S	
Trench devoid of archaeology. Consists of ploughsoil and subsoil overlying natural geology of sandy gravel				Length (m)		30	
				Width (m)		2	
				Avg. depth (m)		0.84	
Context No.	Type	Fill Of	Width (m)	Depth (m)	Description	Finds	Date
7700	Layer			0.33	Ploughsoil. Mid grey brown silty sand		
7701	Layer			0.36	Subsoil. Mid orange brown silty sand		
7702	Layer				Natural. Mid orange brown sandy gravel and silty sand		
<b>Trench 78</b>							
General description				Orientation		E-W	
Trench devoid of archaeology. Consists of ploughsoil and subsoil overlying natural geology of silty sand and gravels.				Length (m)		30	
				Width (m)		2	
				Avg. depth (m)		0.48	

Context No.	Type	Fill Of	Width (m)	Depth (m)	Description	Finds	Date
7800	Layer			0.31	Ploughsoil. Dark grey brown, silty clay		
7801	Layer			0.17	Subsoil. Mid orangey brown, silty sand		
7802	Layer				Natural. Mid red/yellow brown, silty sand and gravels		
<b>Trench 79</b>							
General description				Orientation		N-S	
Trench devoid of archaeology. Consists of ploughsoil and subsoil overlying natural geology of silty sand with gravels.				Length (m)		30	
				Width (m)		2	
				Avg. depth (m)		0.46	
Context No.	Type	Fill Of	Width (m)	Depth (m)	Description	Finds	Date
7900	Layer			0.28	Ploughsoil. Dark grey brown, silty clay	flint	
7901	Layer			0.18	Subsoil. Mid orangey brown, silty sand		
7902	Layer				Natural. Mid red brown, silty sand with gravels		
<b>Trench 80</b>							
General description				Orientation		E-W	
Trench revealed a tree throw containing pottery, a linear and an unexcavated pit/tree throw. Consists of ploughsoil and subsoil overlying natural geology of silty sand and gravels.				Length (m)		30	
				Width (m)		2	
				Avg. depth (m)		0.5	
Context No.	Type	Fill Of	Width (m)	Depth (m)	Description	Finds	Date
8000	Layer			0.3	Ploughsoil. Dark grey brown, silty clay	flint	
8001	Layer			0.2	Subsoil. Mid orangey brown, silty sand		
8002	Layer				Natural. Mid red/yellow brown, silty sand		
8003	Cut		1.3	0.14	Pit		
8004	Fill	8003	1.3	0.14	Secondary Fill. Mid reddish grey sandy silt friable	pottery flint	?LNeo
8005	Cut		1.28	0.6	Tree Throw. The feature was not completely excavated due to the depth over a meter, so measures are referred only to the excavated part		
8006	Fill	8005	0.7	0.1	Primary Fill. Mid bluish grey sandy silt, not fully excavated	pottery	?LNeo or LBA/IA
8007	Fill	8005	1.28	0.6	Secondary Fill. Dark orangey brown clayey silt, smooth		
8008	Unexcavated feature				Tree Throw. Mid brownish grey sandy silt, compact		
<b>Trench 81</b>							
General description				Orientation		NE-SW	

Trench devoid of archeology. Trench consists of ploughsoil and subsoil overlying natural geology of sandy gravel				Length (m)		30	
				Width (m)		2	
				Avg. depth (m)		0.81	
Context No.	Type	Fill Of	Width (m)	Depth (m)	Description	Finds	Date
8100	Layer			0.29	Ploughsoil. Dark greyish brown, silty sand		
8101	Layer			0.31	Subsoil. Mid greyish brown, silty sand		
8102	Layer				Natural. Mid orangish brown, sandy gravel		
<b>Trench 82</b>							
General description				Orientation		NW-SE	
Trench devoid of archeology. Trench consists of ploughsoil and subsoil overlying one colluvial layer and natural geology of sandy gravel				Length (m)		30	
				Width (m)		2	
				Avg. depth (m)		0.81	
Context No.	Type	Fill Of	Width (m)	Depth (m)	Description	Finds	Date
8200	Layer			0.28	Ploughsoil. Dark greyish brown, silty sand		
8201	Layer			0.31	Subsoil. Mid greyish brown, silty sand		
8202	Layer			0.21	Colluvial Layer. Mid orangish brown, silty sand		
8203	Layer				Natural. Mid orangish brown, sandy gravel		
<b>Trench 83</b>							
General description				Orientation		E-W	
Trench revealed one posthole. Trench consists of ploughsoil and subsoil overlying one colluvial layer and natural geology of sandy gravel				Length (m)		30	
				Width (m)		2	
				Avg. depth (m)		0.72	
Context No.	Type	Fill Of	Width (m)	Depth (m)	Description	Finds	Date
8300	Layer			0.3	Ploughsoil. Dark greyish brown, silty sand	flint	
8301	Layer			0.2	Subsoil. Mid greyish brown, silty sand		
8302	Layer			0.23	Colluvial Layer. Mid orangish brown, silty sand		
8303	Layer				Natural. Mid orangish brown, sandy gravel		
8304	Cut		0.27	0.08	Posthole. 0.20m length		
8305	Fill	8304	0.27	0.08	Secondary Fill. dark brownish grey, clay silt		
<b>Trench 84</b>							
General description				Orientation		N-S	
Trench consists of ploughsoil and subsoil overlying one colluvial layer and natural geology of sandy gravel				Length (m)		30	
				Width (m)		2	
				Avg. depth (m)		0.82	
Context No.	Type	Fill Of	Width (m)	Depth (m)	Description	Finds	Date

8400	Layer			0.3	Ploughsoil. Dark greyish brown, silty sand		
8401	Layer			0.28	Subsoil. Mid greyish brown, silty sand		
8402	Layer			0.21	Colluvial Layer. Mid orangish brown, silty sand		
8403	Layer				Natural. Mid orangish brown, sandy gravel		

#### Trench 85

General description				Orientation		N-S	
Trench devoid of archaeology. Consists of ploughsoil and subsoil overlying natural geology of silty sand with gravels				Length (m)		30	
				Width (m)		2	
				Avg. depth (m)		0.55	
Context No.	Type	Fill Of	Width (m)	Depth (m)	Description	Finds	Date
8500	Layer			0.28	Ploughsoil. Mid grey brown silty sand	flint	
8501	Layer			0.25	Subsoil. Mid orange brown silty sand		
8502	Layer				Natural. Mid orange brown sandy gravel and patches of silty sand		

#### Trench 86

General description				Orientation		E-W	
Trench devoid of archaeology. Consists of ploughsoil and subsoil overlying natural geology of silty sand with gravels				Length (m)		30	
				Width (m)		2	
				Avg. depth (m)		0.5	
Context No.	Type	Fill Of	Width (m)	Depth (m)	Description	Finds	Date
8600	Layer			0.3	Ploughsoil. Mid grey brown silty sand		
8601	Layer			0.16	Subsoil. Mid orange brown silty sand		
8602	Layer				Natural. Mid orange brown silty sand with gravels		

#### Trench 87

General description				Orientation		N-S	
Trench devoid of archaeology. Consists of ploughsoil and subsoil overlying natural geology of sandy gravel				Length (m)		30	
				Width (m)		2	
				Avg. depth (m)		0.6	
Context No.	Type	Fill Of	Width (m)	Depth (m)	Description	Finds	Date
8700	Layer			0.19	Ploughsoil. Mid grey brown silty sand		
8701	Layer			0.34	Subsoil. Mid orange brown silty sand		
8702	Layer				Natural. Mid orange brown sandy gravel		

#### Trench 88

General description				Orientation		NW-SE	
---------------------	--	--	--	-------------	--	-------	--

Trench devoid of archaeology. Consists of ploughsoil and subsoil overlying natural geology of sandy gravel				Length (m)		30	
				Width (m)		2	
				Avg. depth (m)		0.45	
Context No.	Type	Fill Of	Width (m)	Depth (m)	Description	Finds	Date
8800	Layer			0.22	Ploughsoil. Mid grey brown silty sand		
8801	Layer			0.18	Subsoil. Mid orange brown silty sand		
8802	Layer				Natural. Mid orange brown sandy gravel		
<b>Trench 89</b>							
General description				Orientation		NE-SW	
Trench devoid of archaeology. Consists of ploughsoil and subsoil overlying natural geology of silty sand with gravels				Length (m)		30	
				Width (m)		2	
				Avg. depth (m)		0.52	
Context No.	Type	Fill Of	Width (m)	Depth (m)	Description	Finds	Date
8900	Layer			0.24	Ploughsoil. Mid grey brown silty sand		
8901	Layer			0.27	Subsoil. Mid orange brown silty sand		
8902	Layer				Natural. Mid orange brown silty sand with gravels		
<b>Trench 90</b>							
General description				Orientation		E-W	
Trench devoid of archeology. Trench consists of ploughsoil and subsoil overlying two colluvial layer. Natural not exposed				Length (m)		30	
				Width (m)		2	
				Avg. depth (m)		1	
Context No.	Type	Fill Of	Width (m)	Depth (m)	Description	Finds	Date
9000	Layer			0.27	Ploughsoil. Dark greyish brown, silty sand		
9001	Layer			0.31	Subsoil. Mid greyish brown, silty sand		
9002	Layer			0.2	Colluvial Layer. Mid yellowish brown, silty sand		
9003	Layer				Colluvial Layer. Mid orangish brown, silty sand		
<b>Trench 91</b>							
General description				Orientation		E-W	
Trench devoid of archeology. Trench consists of ploughsoil and subsoil overlying one colluvial layer and natural geology of sandy gravel				Length (m)		30	
				Width (m)		2	
				Avg. depth (m)		0.95	
Context No.	Type	Fill Of	Width (m)	Depth (m)	Description	Finds	Date
9100	Layer			0.36	Ploughsoil. Dark greyish brown, silty sand		
9101	Layer			0.31	Subsoil. Mid greyish brown, silty sand		

9102	Layer			0.24	Colluvial Layer. Mid orangish brown, silty sand		
9103	Layer				Natural. Mid orangish brown, sandy gravel		
<b>Trench 92</b>							
General description				Orientation		N-S	
Trench devoid of archeology. Trench consists of ploughsoil and subsoil overlying two colluvial layer and natural geology of sandy gravel. Natural partially exposed				Length (m)		30	
				Width (m)		2	
				Avg. depth (m)		1	
Context No.	Type	Fill Of	Width (m)	Depth (m)	Description	Finds	Date
9200	Layer			0.29	Ploughsoil. Dark greyish brown, silty sand		
9201	Layer			0.31	Subsoil. Mid greyish brown, silty sand		
9202	Layer			0.2	Colluvial Layer. Mid yellowish brown, silty sand		
9203	Layer			0.2	Colluvial Layer. Mid orangish brown, silty sand		
9204	Layer				Natural. Mid orangish brown, sandy gravel		
<b>Trench 93</b>							
General description				Orientation		E-W	
Trench revealed one tree throw. Trench consists of ploughsoil and subsoil overlying two colluvial layer and natural geology of sandy gravel.				Length (m)		30	
				Width (m)		2	
				Avg. depth (m)		1	
Context No.	Type	Fill Of	Width (m)	Depth (m)	Description	Finds	Date
9300	Layer			0.31	Ploughsoil. Dark greyish brown, silty sand	flint	
9301	Layer			0.3	Subsoil. Mid greyish brown, silty sand		
9302	Layer			0.23	Colluvial Layer. Mid orangish brown, silty sand		
9303	Layer			0.21	Colluvial Layer. Mid yellowish brown, silty sand		
9304	Layer				Natural. Mid orangish brown, sandy gravel		
9305	Unexcavated feature		0.98		Tree Throw. Dark grey brown clay silt.		
<b>Trench 94</b>							
General description				Orientation		E-W	
Trench devoid of archaeology. Consists of ploughsoil and subsoil overlying natural geology of silty sand with gravels				Length (m)		30	
				Width (m)		2	
				Avg. depth (m)		0.9	
Context No.	Type	Fill Of	Width (m)	Depth (m)	Description	Finds	Date
9400	Layer			0.23	Ploughsoil. Mid grey brown silty sand		
9401	Layer			0.5	Subsoil. Mid orange brown silty sand		

9402	Layer				Natural. Mid orange brown silty sand with gravels		
<b>Trench 95</b>							
General description				Orientation		N-S	
Trench devoid of archaeology. Consists of ploughsoil and subsoil overlying natural geology of silty sand and gravel				Length (m)		30	
				Width (m)		2	
				Avg. depth (m)		0.8	
Context No.	Type	Fill Of	Width (m)	Depth (m)	Description	Finds	Date
9500	Layer			0.25	Ploughsoil. Mid grey brown silty sand		
9501	Layer			0.46	Subsoil. Mid orange brown silty sand		
9502	Layer				Natural. Mid reddish brown silty sand and sandy gravels		
<b>Trench 96</b>							
General description				Orientation		NE-SW	
Trench revealed a single ditch terminus. Consists of ploughsoil and subsoil overlying natural geology of sandy gravel with patches of silty sand				Length (m)		30	
				Width (m)		2	
				Avg. depth (m)		0.75	
Context No.	Type	Fill Of	Width (m)	Depth (m)	Description	Finds	Date
9600	Layer			0.33	Ploughsoil. Mid grey brown silty sand		
9601	Layer			0.36	Subsoil. Mid orange brown silty sand		
9602	Layer				Natural. Mid orange brown sandy gravel		
9603	Cut		1.07	0.27	Ditch. Terminus		
9604	Fill	9603	1.07	0.13	Secondary Fill. mid orangey brown slight grey, clay silt		
9605	Fill	9603	1.07	0.14	Deliberate Backfill. mid greyish brown darker patches, clay silt		
<b>Trench 97</b>							
General description				Orientation		NE-SW	
Trench revealed one ditch. Consists of ploughsoil and subsoil overlying natural geology of sandy gravel				Length (m)		30	
				Width (m)		2	
				Avg. depth (m)		0.63	
Context No.	Type	Fill Of	Width (m)	Depth (m)	Description	Finds	Date
9700	Layer			0.26	Ploughsoil. Mid grey brown silty sand		
9701	Layer			0.24	Subsoil. Mid orange brown silty sand		
9702	Layer				Natural. Mid orange brown sandy gravel with patches of silty sand		
9703	Cut		1.88	0.3	Ditch		



9704	Fill	9703	1.88	0.3	Deliberate Backfill. mid to dark grey mixed greyish orange, clay silt		
<b>Trench 98</b>							
General description				Orientation		E-W	
Trench devoid of archaeology. Consists of ploughsoil overlying subsoil, overlying natural geology of silty sand				Length (m)		30	
				Width (m)		2	
				Avg. depth (m)		0.9	
Context No.	Type	Fill Of	Width (m)	Depth (m)	Description	Finds	Date
9800	Layer			0.27	Ploughsoil. Mid grey brown silty sand	flint	
9801	Layer			0.29	Subsoil. Mid orange brown silty sand		
9802	Layer				Natural. Mid orange brown silty sand with occasional gravels		
<b>Trench 99</b>							
General description				Orientation		NE-SW	
Trench revealed one ditch, small discrete and a post-med discrete. Consists of ploughsoil overlying natural geology of silty sand and gravels.				Length (m)		30	
				Width (m)		2	
				Avg. depth (m)		0.33	
Context No.	Type	Fill Of	Width (m)	Depth (m)	Description	Finds	Date
9900	Layer			0.34	Ploughsoil. Dark grey brown, silty clay	flint	
9901	Layer				Natural. Mid yellow brown, silty sand and gravels		
9902	Cut		1	0.35	Ditch		
9903	Fill	9902	1	0.35	Secondary Fill. Mid grey brown, gravelly silt. Natural flint subangular and -rounded up to 40mm.		
9904	Cut		1.1	0.36	Pit		
9905	Fill	9904	1.1	0.36	Secondary Fill. Mid grey brown sandy silt. 2 % Natural flint.		
9906	Cut		1.8	0.68	Modern		
9907	Fill	9906	0.3	0.08	Deliberate Backfill. Dark greyish brown. Sandy silt.		
9908	Fill	9906	0.58	0.12	Deliberate Backfill. Dark brown grey. Gravelly silt.		
9909	Fill	9906	1.84	0.28	Deliberate Backfill. Mid brownish grey sandy silt. Charcoal.		
9910	Fill	9906	1.6	0.3	Deliberate Backfill. Mid yellowish grey gravelly silt.		
9911	Fill	9906	1.38	0.24	Deliberate Backfill. Dark brownish grey charcoal rich sandy silt. Iron.	iron	20thC
9912	Fill	9906	1.16	0.1	Deliberate Backfill. Mid yellow brown sandy silt.		

9913	Fill	9906	1.6	0.2	Deliberate Backfill. Dark brownish grey sandy silt. Charcoal. Glass.		
<b>Trench 100</b>							
General description				Orientation		N-S	
Trench devoid of archaeology. Consists of ploughsoil overlying subsoil, overlying natural geology of silty sand				Length (m)		30	
				Width (m)		2	
				Avg. depth (m)		0.66	
Context No.	Type	Fill Of	Width (m)	Depth (m)	Description	Finds	Date
10000	Layer			0.23	Ploughsoil. Mid grey brown silty sand		
10001	Layer			0.3	Subsoil. Mid orange brown silty sand		
10002	Layer				Natural. Mid orange brown silty sand with occasional gravels		
<b>Trench 101</b>							
General description				Orientation		E-W	
Trench devoid of archeology. Trench consists of ploughsoil and subsoil overlying one colluvial layer and natural geology of sandy gravel				Length (m)		30	
				Width (m)		2	
				Avg. depth (m)		0.81	
Context No.	Type	Fill Of	Width (m)	Depth (m)	Description	Finds	Date
10100	Layer			0.28	Ploughsoil. Dark greyish brown, silty sand	flint	
10101	Layer			0.27	Subsoil. Mid greyish brown, silty sand		
10102	Layer			0.2	Colluvial Layer. Mid orangish brown, silty sand		
10103	Layer				Natural. Mid yellowish brown, silty sand		
<b>Trench 102</b>							
General description				Orientation		N-S	
Trench revealed one ditch. Trench consists of ploughsoil and subsoil overlying one colluvial layer and natural geology of sandy gravel				Length (m)		30	
				Width (m)		2	
				Avg. depth (m)		0.8	
Context No.	Type	Fill Of	Width (m)	Depth (m)	Description	Finds	Date
10200	Layer			34	Ploughsoil. Dark greyish brown, silty sand		
10201	Layer			0.19	Subsoil. Mid greyish brown, silty sand		
10202	Layer			0.29	Colluvial Layer. Mid orangish brown, silty sand		
10203	Layer				Natural. Mid orangish brown, sandy gravel		
10204	Unexcavated feature		0.74		Ditch. Mid brown grey sandy silt		
<b>Trench 103</b>							
General description				Orientation		N-S	

Trench devoid of archaeology. Ploughsoil and subsoil overlying natural geology of silty sand with gravels				Length (m)		30	
				Width (m)		2	
				Avg. depth (m)		0.8	
Context No.	Type	Fill Of	Width (m)	Depth (m)	Description	Finds	Date
10300	Layer			0.32	Ploughsoil. Mid grey brown silty sand		
10301	Layer			0.6	Subsoil. Mid orange brown silty sand		
10302	Layer				Natural. Mid orange brown silty sand with occasional gravels		
10303	Unexcavated feature		0.6		Tree Throw. Mid grey brown. Silty clay. Burnt organic material half circle sides.		
<b>Trench 104</b>							
General description				Orientation		N-S	
Trench revealed a natural feature. Ploughsoil and subsoil overlying natural geology of silty sand with gravel.				Length (m)		30	
				Width (m)		2	
				Avg. depth (m)		0.7	
Context No.	Type	Fill Of	Width (m)	Depth (m)	Description	Finds	Date
10400	Layer			0.28	Ploughsoil. Mid grey brown silty sand		
10401	Layer			0.32	Subsoil. Mid orange brown silty sand		
10402	Layer				Natural. Mid orange/yellow brown silty sand with patches of gravel		
10403	Cut		0.44	0.03	Natural Feature. NW-SE extremely shallow linear, probably infilled hollow at interface of natural gravel and natural silt.		
10404	Fill	10403	0.44	0.03	Secondary Fill. Mid grey brown clay silt		
<b>Trench 105</b>							
General description				Orientation		E-W	
Trench devoid of archaeology. Consists of ploughsoil and subsoil overlying natural geology of silty sand with gravels.				Length (m)		30	
				Width (m)		2	
				Avg. depth (m)		0.7	
Context No.	Type	Fill Of	Width (m)	Depth (m)	Description	Finds	Date
10500	Layer			0.31	Ploughsoil. Dark grey brown, silty clay		
10501	Layer			0.39	Subsoil. Mid brown, silty sand		
10502	Layer				Natural. Mid yellow red, silty sand with gravels		
<b>Trench 106</b>							
General description				Orientation		N-S	
				Length (m)		30	

Trench devoid of archaeology. Consists of ploughsoil and subsoil overlying natural geology of silty sand with gravels.				Width (m)		2	
				Avg. depth (m)		0.75	
Context No.	Type	Fill Of	Width (m)	Depth (m)	Description	Finds	Date
10600	Layer			0.28	Ploughsoil. Dark grey brown, silty clay		
10601	Layer			0.47	Subsoil. Mid brown, silty sand		
10602	Layer				Natural. Mid yellow red, silty sand with gravels		
<b>Trench 107</b>							
General description				Orientation		E-W	
Trench revealed two tree throws. Consists of ploughsoil and subsoil overlying natural geology of silty sand with gravels.				Length (m)		30	
				Width (m)		2	
				Avg. depth (m)		0.73	
Context No.	Type	Fill Of	Width (m)	Depth (m)	Description	Finds	Date
10700	Layer			0.33	Ploughsoil. Dark grey brown, silty clay		
10701	Layer			0.4	Subsoil. Mid brown, silty sand		
10702	Layer				Natural. Mid yellow red, silty sand with gravels		
10703	Cut		1.18	0.16	Tree Throw		
10704	Fill	10703	1.18	0.16	Primary Fill. Mid greyish brown, silty sand		
10705	Unexcavated feature		1.22		Tree Throw. Mid greyish brown, silty sand		
<b>Trench 108</b>							
General description				Orientation		N-S	
Trench revealed a single natural feature. Consisted of ploughsoil and subsoil overlying the natural geology of sand and gravel				Length (m)		30	
				Width (m)		2	
				Avg. depth (m)		0.6	
Context No.	Type	Fill Of	Width (m)	Depth (m)	Description	Finds	Date
10800	Layer			0.35	Ploughsoil. Mid grey brown silty sand		
10801	Layer			0.17	Subsoil. Mid orange brown silty sand		
10802	Layer				Natural. Mid orange brown silty sand with occasional gravels		
10803	Cut		0.4	0.03	Natural Feature. Probable base of a burrow/tree throw observed in 108		
10804	Fill	10803	0.4	0.03	Secondary Fill. Homogeneous, Mid grey brown silty clay. No finds		
<b>Trench 109</b>							
General description				Orientation		E-W	
Trench contained one tree throw. Consists of ploughsoil and subsoil overlying natural geology of silty sand with gravels.				Length (m)		30	
				Width (m)		2	
				Avg. depth (m)		0.71	

Context No.	Type	Fill Of	Width (m)	Depth (m)	Description	Finds	Date
10900	Layer			0.32	Ploughsoil. Dark grey brown, silty clay	flint	
10901	Layer			0.39	Subsoil. Mid brown, silty sand		
10902	Layer				Natural. Mid red, silty sand with gravels		
10903	Unexcavated feature		1		Tree Throw. Mid grey brown. Silty clay. Rare bits of charcoal up to 5mm.		

### Trench 110

General description				Orientation		N-S	
Trench devoid of archeology. Trench consists of ploughsoil and subsoil overlying natural geology of sandy gravel				Length (m)		30	
				Width (m)		2	
				Avg. depth (m)		0.68	
Context No.	Type	Fill Of	Width (m)	Depth (m)	Description	Finds	Date
11000	Layer			0.31	Ploughsoil. Dark greyish brown, silty sand		
11001	Layer			0.42	Subsoil. Mid greyish brown, silty sand		
11002	Layer				Natural. Mid orange brown, sandy gravels.		
11003	Layer				Colluvial Layer. Layer though to be colluvial, just over cut natural. Context doesn't exist.		

### Trench 111

General description				Orientation		E-W	
Trench reveals remains of hollow way. Consists of ploughsoil overlying subsoil overlying natural geology of silty sand with gravels.				Length (m)		30	
				Width (m)		2	
				Avg. depth (m)		0.6	
Context No.	Type	Fill Of	Width (m)	Depth (m)	Description	Finds	Date
11100	Layer			0.26	Ploughsoil. Mid grey brown silty sand		
11101	Layer			0.25	Subsoil. Mid orange brown silty sand		
11102	Layer				Natural. Mid orange brown silty sand with occasional gravels		
11103	Cut		0.71	0.35	Ditch		
11104	Fill	11103	0.71	0.35	Secondary Fill. Mid grey brown silty clay, loose, frequent stone inclusions.		
11105	Void						
11106	Layer		1.3	0.13	Natural. Mid grey brown silt clay, loose, occasional stone inclusions.		

### Trench 112

General description				Orientation		N-S	
				Length (m)		30	

Trench revealed one ditch. Consists of ploughsoil and subsoil overlying natural geology of silty sand and gravels				Width (m)		2	
				Avg. depth (m)		0.45	
Context No.	Type	Fill Of	Width (m)	Depth (m)	Description	Finds	Date
11200	Layer			0.4	Ploughsoil. Mid grey brown silty sand		
11201	Layer			0.22	Subsoil. Mid orange brown silty sand		
11202	Layer				Natural. Mid orange brown silty sand with occasional gravels		
11203	Cut		1.92	0.19	Ditch. Cut of Ditch		
11204	Fill	11203	0.5	0.12	Primary Fill. Mid Grey Brown. Sandy Silt.		
11205	Fill	11203	0.44	0.14	Primary Fill. Mid grey brown sandy silt.		
11206	Fill	11203	1.5	0.19	Secondary Fill. Light grey brown sandy silt.	flint fired clay	

### Trench 113

General description				Orientation		E-W	
Trench revealed one ditch. Consists of ploughsoil and subsoil overlying natural geology of silty sand with gravels				Length (m)		30	
				Width (m)		2	
				Avg. depth (m)		0.42	
Context No.	Type	Fill Of	Width (m)	Depth (m)	Description	Finds	Date
11300	Layer			0.3	Ploughsoil. Mid grey brown silty sand		
11301	Layer				Natural. Mid orange brown silty sand with occasional gravels		
11302	Cut		0.7	0.19	Ditch		
11303	Fill	11302	0.7	0.19	Deliberate Backfill. Mid yellow brown, clay silt, friable, some small rounded stones		

### Trench 114

General description				Orientation		N-S	
Trench revealing a ditch and a ditch terminus. Consists of ploughsoil and subsoil overlying natural geology of silty sand and gravels.				Length (m)		30	
				Width (m)		2	
				Avg. depth (m)		0.62	
Context No.	Type	Fill Of	Width (m)	Depth (m)	Description	Finds	Date
11400	Layer			0.32	Ploughsoil. Dark grey brown, silty clay		
11401	Layer			0.3	Subsoil. Mid brown, silty sand		
11402	Layer				Natural. Mid yellow red, clayey sand with gravels		
11403	Cut		0.72	0.32	Ditch		
11404	Fill	11403	0.72	0.32	Primary Fill. Pale yellow grey. Sandy silt		
11405	Cut		0.9	0.13	Ditch. Terminus		
11406	Fill	11405	0.9	0.12	Primary Fill. Pale yellow grey. Sandy silt		

11407	Fill		1.2	0.05	Other Fill. Subsoil fill in natural dip. Same as (11401)		
11408	Fill		1.22	0.04	Other Fill. Same as (11407)		
<b>Trench 115</b>							
General description				Orientation		E-W	
Trench revealed one pit. Trench consists of topsoil and subsoil overlying a colluvial layer and natural geology of silty sand with gravel				Length (m)		30	
				Width (m)		2	
				Avg. depth (m)		0.52	
Context No.	Type	Fill Of	Width (m)	Depth (m)	Description	Finds	Date
11500	Layer			0.32	Ploughsoil. Dark grey brown, silty clay		
11501	Layer			0.2	Subsoil. Mid brown, silty sand		
11502	Layer				Natural. Mid yellow red, silty sand with gravels		
11503	Cut		0.88	0.14	Pit		
11504	Fill	11503	0.88	0.14	Deliberate Backfill		
11505	Layer		2.9	0.2	Colluvial Layer. Light whitish grey, silty sand		
<b>Trench 116</b>							
General description				Orientation		N-S	
Trench revealing a tree throw. Consists of ploughsoil and subsoil overlying natural geology of silty sand.				Length (m)		30	
				Width (m)		2	
				Avg. depth (m)		0.55	
Context No.	Type	Fill Of	Width (m)	Depth (m)	Description	Finds	Date
11600	Layer			0.33	Ploughsoil. Dark grey brown, silty clay		
11601	Layer			0.22	Subsoil. Mid brown, silty sand		
11602	Layer				Natural. Mid yellow red, silty sand		
11603	Cut		1.26	0.44	Tree Throw. Observed in the east edge of 116. Not excavated to depth due to trench depth. Sides not fully exposed as they narrow approaching the trench edge.		
11604	Fill	11603	1.26	0.44	Secondary Fill. Dark grey brown, silty clay		
11605	Void						
11606	Void						
11607	Void						
11608	Void						
<b>Trench 117</b>							
General description				Orientation		NW-SE	
Trench revealed one ditch. Consists of ploughsoil and subsoil overlying natural geology of silty sand.				Length (m)		30	
				Width (m)		2	

				Avg. depth (m)		0.53	
Context No.	Type	Fill Of	Width (m)	Depth (m)	Description	Finds	Date
11700	Layer			0.32	Ploughsoil. Dark grey brown, silty clay		
11701	Layer			0.21	Subsoil. Mid brown, silty sand		
11702	Layer				Natural. Mid yellow red, silty sand		
11703	Cut		0.6	0.26	Ditch		
11704	Fill	11703	0.6	0.26	Secondary Fill. mid orangey brown slight grey, clay silt		

### Trench 118

General description				Orientation		E-W	
Trench revealing one hedgerow and one ditch terminus and one discrete. Consists of ploughsoil overlying natural geology of silty sand and gravels.				Length (m)		30	
				Width (m)		2	
				Avg. depth (m)		0.38	
Context No.	Type	Fill Of	Width (m)	Depth (m)	Description	Finds	Date
11800	Layer			0.38	Ploughsoil. Dark grey brown, silty clay		
11801	Layer				Natural. Light yellow brown, silty sand and gravels		
11802	Cut		0.86	0.34	Ditch		
11803	Fill	11802	0.86	0.34	Secondary Fill. Mid blue grey, sandy silt. Clayey patches. Natural flint.		
11804	Cut		1.1	0.26	Pit		
11805	Fill	11804	1.1	0.26	Secondary Fill. Mid brown grey, sandy silt. Natural flint.		
11806	Cut		0.8	0.49	Hedgerow		
11807	Fill	11806	0.8	0.49	Primary Fill. Mid brown grey loose silty sand. natural flint. Rooting.		

### Trench 119

General description				Orientation		N-S	
Trench revealing ditch and ditch terminus. Consists of ploughsoil overlying natural geology of silty sand and gravels.				Length (m)		30	
				Width (m)		2	
				Avg. depth (m)		0.38	
Context No.	Type	Fill Of	Width (m)	Depth (m)	Description	Finds	Date
11900	Layer			0.38	Ploughsoil. Dark grey brown, silty clay		
11901	Layer				Natural. Light yellow brown, silty sand and gravel		
11902	Cut		1.36	0.18	Ditch		
11903	Fill	11902	1.36	0.18	Secondary Fill. mid greyish brown, sandy gravelly silt		
11904	Cut		0.96	0.07	Ditch		



11905	Fill	11904	0.96	0.07	Deliberate Backfill. mid brownish grey mixed light yellow, sandy gravelly silt		
<b>Trench 120</b>							
General description				Orientation		NW-SE	
Trench revealed one ditch, two pits and two termini. Consists of ploughsoil overlying natural geology of silty sand and gravels.				Length (m)		30	
				Width (m)		2	
				Avg. depth (m)		0.35	
Context No.	Type	Fill Of	Width (m)	Depth (m)	Description	Finds	Date
12000	Layer			0.35	Ploughsoil. Dark grey brown, silty clay		
12001	Layer				Natural. Mid yellow brown, silty sand and gravels		
12002	Cut		0.61	0.22	Ditch		
12003	Fill	12002	0.61	0.22	Primary Fill. Light brownish grey, silty sand		
12004	Cut		1.1	0.12	Ditch		
12005	Fill	12004	1.1	0.12	Primary Fill. Light brownish grey, silty sand		
12006	Cut		0.88	0.18	Pit		
12007	Fill	12006	0.88	0.18	Primary Fill. Mid greyish brown, silty sand		
12008	Cut		0.98	0.3	Ditch		
12009	Fill	12008	0.98	0.3	Primary Fill. Mid greyish brown, silty sand		
12010	Cut		2.18	0.2	Pit		
12011	Fill	12010	2.18	0.2	Primary Fill. Mid brownish grey, silty sand		
<b>Trench 121</b>							
General description				Orientation		NE-SW	
Trench revealed two ring ditches and one ditch. Consists of ploughsoil overlying natural geology of silty sand and gravels.				Length (m)		30	
				Width (m)		2	
				Avg. depth (m)		0.35	
Context No.	Type	Fill Of	Width (m)	Depth (m)	Description	Finds	Date
12100	Layer			0.35	Ploughsoil. Dark grey brown, silty clay		
12101	Layer				Natural. Light yellow brown, silty sand and gravels		
12102	Cut		2.12	0.72	Ditch		
12103	Fill	12102	2.12	0.44	Primary Fill. Mid grey brown silty sand with large amounts of gravel	flint	
12104	Cut		1.24	0.28	Ditch		
12105	Fill	12104	1.24	0.28	Primary Fill. Mid greyish brown, silty sand		
12106	Cut		1.18	0.48	Ring Ditch		
12107	Fill	12106	1.18	0.26	Primary Fill. Light whitish grey, silty sand		
12108	Fill	12106	0.74	0.24	Secondary Fill. Mid greyish brown, silty sand		

12109	Fill	12102	1.08	0.3	Secondary Fill. Dark brownish grey with frequent with stones, silty sand		
<b>Trench 122</b>							
General description				Orientation		NW-SE	
Trench revealing two ditches. Consists of ploughsoil overlying natural geology of silty sand and gravels.				Length (m)		30	
				Width (m)		2	
				Avg. depth (m)		0.33	
Context No.	Type	Fill Of	Width (m)	Depth (m)	Description	Finds	Date
12200	Layer			0.33	Ploughsoil. Dark grey brown, silty clay	flint	
12201	Layer				Natural. Light yellow brown, silty sand and gravels		
12202	Cut		0.78	0.18	Ditch		
12203	Fill	12202	0.78	0.18	Primary Fill. Mid grey brown silty sand with large amounts of gravel	flint	
12204	Unexcavated feature		2.7		Ditch. Mid grey brown silty sand with large amounts of gravel		
<b>Trench 123</b>							
General description				Orientation		N-S	
Trench devoid of archaeology. Trench consists of ploughsoil and subsoil overlying natural geology of sandy gravel				Length (m)		30	
				Width (m)		2	
				Avg. depth (m)		0.61	
Context No.	Type	Fill Of	Width (m)	Depth (m)	Description	Finds	Date
12300	Layer			0.31	Ploughsoil. Dark greyish brown, silty sand		
12301	Layer			0.28	Subsoil. Mid greyish brown, silty sand		
12302	Layer				Natural. Mid orangish brown, sandy gravel		
<b>Trench 124</b>							
General description				Orientation		N-S	
Trench revealed one E-W ditch. Trench consists of ploughsoil and subsoil overlying natural geology of sandy gravel				Length (m)		30	
				Width (m)		2	
				Avg. depth (m)		0.62	
Context No.	Type	Fill Of	Width (m)	Depth (m)	Description	Finds	Date
12400	Layer			0.31	Ploughsoil. Dark greyish brown, silty sand	flint	
12401	Layer			0.21	Subsoil. Mid greyish brown, silty sand		
12402	Layer				Natural. Mid orangish brown with light yellowish brown patches, sandy gravel		
12403	Cut		2.28	0.4	Ditch		

12404	Fill	12403	2.28	0.4	Secondary Fill. mid brownish grey, sandy gravelly silt	Pottery	MIA
<b>Trench 125</b>							
General description				Orientation		E-W	
Trench revealed one ditch. Trench consists of ploughsoil overlying natural geology of silty sand				Length (m)		30	
				Width (m)		2	
				Avg. depth (m)		0.38	
Context No.	Type	Fill Of	Width (m)	Depth (m)	Description	Finds	Date
12500	Layer			0.38	Ploughsoil. Dark greyish brown, silty sand		
12501	Layer				Natural. Mid orangish brown, silty sand		
12502	Cut		1.6	0.55	Ditch		
12503	Fill	12502	1.6	0.16	Secondary Fill. Mid brownish grey, sandy silt	Pottery	?MIA
12504	Fill	12502	1.6	0.13	Secondary Fill. Yellowish grey, sandy silt		
12505	Fill	12502	1.6	0.26	Secondary Fill. Mid brownish grey, sandy silt	Pottery	?MIA
<b>Trench 126</b>							
General description				Orientation		NW-SE	
Trench devoid of archaeology. Trench consists of ploughsoil and subsoil overlying natural geology of sandy gravel. Subsoil only present in NW half				Length (m)		30	
				Width (m)		2	
				Avg. depth (m)		0.44	
Context No.	Type	Fill Of	Width (m)	Depth (m)	Description	Finds	Date
12600	Layer			0.3	Ploughsoil. Dark greyish brown, silty sand	flint	
12601	Layer			0.51	Subsoil. Mid greyish brown, silty sand		
12602	Layer				Natural. Mid orangish brown, sandy gravel		
<b>Trench 127</b>							
General description				Orientation		N-S	
Trench devoid of archaeology. Trench consists of ploughsoil overlying natural geology of sandy gravel				Length (m)		30	
				Width (m)		2	
				Avg. depth (m)		0.41	
Context No.	Type	Fill Of	Width (m)	Depth (m)	Description	Finds	Date
12700	Layer			0.41	Ploughsoil. Dark greyish brown, silty sand		
12701	Layer				Natural. Mid orangish brown with light yellowish brown patches, sandy gravel		
12702	Layer		1.2	0.19	Other Layer. Test slot in natural layer		
<b>Trench 128</b>							
General description				Orientation		E-W	

Trench devoid of archaeology. Trench consists of ploughsoil overlying natural geology of silty sand				Length (m)		30	
				Width (m)		2	
				Avg. depth (m)		0.32	
Context No.	Type	Fill Of	Width (m)	Depth (m)	Description	Finds	Date
12800	Layer			0.32	Ploughsoil. Dark greyish brown, silty sand		
12801	Layer				Natural. Mid yellowish brown, silty sand		
<b>Trench 129</b>							
General description				Orientation		N-S	
Trench devoid of archaeology. Trench consists of ploughsoil overlying natural geology of sandy gravel				Length (m)		30	
				Width (m)		2	
				Avg. depth (m)		0.31	
Context No.	Type	Fill Of	Width (m)	Depth (m)	Description	Finds	Date
12900	Layer			0.31	Ploughsoil. Dark greyish brown, silty sand	flint	
12901	Layer				Natural. Mid orangish brown, sandy gravel		
<b>Trench 130</b>							
General description				Orientation		E-W	
Trench revealed one N-S ditch. Trench consists of ploughsoil overlying natural geology of sandy gravel				Length (m)		30	
				Width (m)		2	
				Avg. depth (m)		0.32	
Context No.	Type	Fill Of	Width (m)	Depth (m)	Description	Finds	Date
13000	Layer			0.32	Ploughsoil. Dark greyish brown, silty sand		
13001	Layer				Natural. Mid orangish brown, silty sand		
13002	Cut		0.7	0.26	Ditch		
13003	Fill	13002	0.7	0.26	Secondary Fill. Mid grey brown silty sand.		
<b>Trench 131</b>							
General description				Orientation		N-S	
Trench devoid of archaeology. Trench consists of ploughsoil overlying natural geology of sandy gravel				Length (m)		30	
				Width (m)		2	
				Avg. depth (m)		0.31	
Context No.	Type	Fill Of	Width (m)	Depth (m)	Description	Finds	Date
13100	Layer			0.31	Ploughsoil. Dark greyish brown, silty sand		
13101	Layer				Natural. Mid orangish brown, sandy gravel		
<b>Trench 132</b>							
General description				Orientation		N-S	
				Length (m)		30	
				Width (m)		2	

Trench devoid of archaeology. Trench consists of ploughsoil overlying subsoil and one colluvial layer. Natural not exposed				Avg. depth (m)		1	
Context No.	Type	Fill Of	Width (m)	Depth (m)	Description	Finds	Date
13200	Layer			0.32	Ploughsoil. Dark greyish brown, silty sand	flint	
13201	Layer			0.41	Subsoil. Mid greyish brown, silty sand		
13202	Layer				Colluvial Layer. Mid orangish brown, silty sand		
<b>Trench 133</b>							
General description				Orientation		N-S	
Trench revealed one possible pit. Trench consists of ploughsoil and subsoil overlying one colluvial layer. Natural not exposed				Length (m)		30	
				Width (m)		2	
				Avg. depth (m)		1	
Context No.	Type	Fill Of	Width (m)	Depth (m)	Description	Finds	Date
13300	Layer			0.35	Ploughsoil. Dark greyish brown, silty sand		
13301	Layer			0.38	Subsoil. Mid greyish brown, silty sand		
13302	Layer				Colluvial Layer. Mid orangish brown, silty sand		
13303	Cut		2	0.3	Tree Throw		
13304	Fill	13303	0.3	2	Primary Fill. Mid greyish brown, silty sand		
<b>Trench 134</b>							
General description				Orientation		E-W	
Trench devoid of archaeology. Trench consists of ploughsoil and subsoil overlying one colluvial layer. Natural not exposed				Length (m)		30	
				Width (m)		2	
				Avg. depth (m)		1	
Context No.	Type	Fill Of	Width (m)	Depth (m)	Description	Finds	Date
13400	Layer			0.32	Ploughsoil. Dark greyish brown, silty sand	flint	
13401	Layer			0.51	Subsoil. Mid greyish brown, silty sand		
13402	Layer				Colluvial Layer. Mid orangish brown, silty sand		
<b>Trench 135</b>							
General description				Orientation		N-S	
Trench devoid of archaeology. Consisted of ploughsoil and subsoil overlying natural geology of sand and gravel				Length (m)		30	
				Width (m)		2	
				Avg. depth (m)		0.59	
Context No.	Type	Fill Of	Width (m)	Depth (m)	Description	Finds	Date
13500	Layer			0.32	Ploughsoil. Mid brown grey sand silt		
13501	Layer			0.27	Subsoil. Mid red brown sand silt		
13502	Layer				Natural. Mid red brown sand silt and gravel		

<b>Trench 136</b>							
General description				Orientation		NE-SW	
Trench devoid of archaeology. Consists of ploughsoil and subsoil overlying natural geology of gravelly sand.				Length (m)		30	
				Width (m)		2	
				Avg. depth (m)		0.6	
Context No.	Type	Fill Of	Width (m)	Depth (m)	Description	Finds	Date
13600	Layer			0.4	Ploughsoil. Mid grey brown silty sand		
13601	Layer			0.2	Subsoil. Mid orange brown silty sand		
13602	Layer				Natural. Mid orange brown gravelly silty sand		
<b>Trench 137</b>							
General description				Orientation		N-S	
Trench devoid of archaeology. Consisted of ploughsoil overlying natural geology of sand and gravel				Length (m)		30	
				Width (m)		2	
				Avg. depth (m)		0.34	
Context No.	Type	Fill Of	Width (m)	Depth (m)	Description	Finds	Date
13700	Layer			0.38	Ploughsoil. Mid brown grey sand silt	flint	
13701	Layer				Natural. Mid red brown sand and gravel		
<b>Trench 138</b>							
General description				Orientation		NNE-SSW	
Trench positioned over walls present on historic map. Area of rubble and burnt material exposed at the southern end of trench. Another small spread of rubble at Northern end.				Length (m)		30	
				Width (m)		2.2	
				Avg. depth (m)		0.4	
Context No.	Type	Fill Of	Width (m)	Depth (m)	Description	Finds	Date
13800	Layer			0.4	Ploughsoil. Mid greyish brown sandy silt with occasional rounded pebbles	flint	
13801	Layer				Natural. Mixed blueish yellow and orange sand		
13802	Unexcavated feature				Modern		
13803	Structure				Wall. Possible modern	CBM	18th-19thC
13804	Cut		0.5		Construction Cut. Unexcavated, recorded in plan		
13805	Fill	13804	0.5		Deliberate Backfill. Firm, mid greyish brown, silty clay.		
13806	Structure		0.8	0.1	Other Structure. Concrete slab abutting wall 13803. Possible lintel		
13807	Structure		0.47	0.25	Wall. Possibly modern	CBM iron obj	L19th-20thC
13808	Cut		0.8		Construction Cut. For wall 13807		

13809	Layer		2	0.15	Occupation Layer. Debris layer above wall 13807	CBM	L19th-20thC
13810	Layer			0.26	Other Layer. Demolition layer	CBM	19th-20thC
13811	Layer			0.2	Other Layer. Demolition layer		
13812	Layer			0.1	Other Layer. Demolition layer	CBM iron nail	19th-20thC
13813	Cut		0.88	0.1	Construction Cut. For concrete slab 13806		
<b>Trench 139</b>							
General description				Orientation		N-S	
Trench has one feature running E-W which may be related to the building shown on historic map				Length (m)		30	
				Width (m)		2.2	
				Avg. depth (m)		0.45	
Context No.	Type	Fill Of	Width (m)	Depth (m)	Description	Finds	Date
13900	Layer			0.4	Ploughsoil. Mid brown grey sandy silt with rounded pebbles throughout	flint	
13901	Layer				Natural. Light yellowish orange sand with rounded pebbles at Southern end of trench		
13902	Void						
13904	Cut		0.38	0.2	Posthole. Rectangular post hole		
13905	Fill	13904	0.38	0.2	Secondary Fill. Firm, dark greyish brown, silty sand.	CBM	L19th-20thC
13906	Unexcavated feature		0.16		Beamslot. Rectangular slot , Very dark grey, silty sand. >0.63m long		
13907	Fill				Secondary Fill. Dark demolition like material		
13908	Unexcavated feature		0.36		Beamslot. Rectangular slot, very dark grey, silty fine sand, >0.73 from loe		
13909	finds ref.					CBM, clay pipe	18th-19thC
13910	Unexcavated feature		0.32		Beamslot. Rectangular, very dark grey, silty sand. extends 0.75m from loe		
13911	Void						
13912	Unexcavated feature		0.32		Beamslot. Rectangular, very dark grey, silty fine sand. 0.94m long		
13913	Void						
13914	Unexcavated feature		0.18		Posthole. Square cut, very dark grey, silty fine sand		
13915	Void						
13916	Cut		0.28	0.15	Posthole. Square cut		
13917	Fill		0.28	0.15	Secondary Fill. Firm, very dark grey, silty sand. (demolition material)	CBM	18th-19thC
13918	Unexcavated feature		0.58		Pit. Poorly defined irregular pit. dark grey		

					brown, fine sand. >1.7m long		
13919	Void						
13920	Unexcavated feature				Pit. Large irregular poorly defined pit, mixed light yellow and mid yellow brown silty fine sand. extends beyond loe >2.6m x2m		
13921	finds ref.					CBM, clay pipe	18th-19thC
13922	Cut		2.17	0.18	Ditch. Purpose unclear, post-med		
13923	Fill	13922	2.17	0.18	Primary Fill. Firm, dark brownish grey, clayey sand		
13924	Layer			0.13	Other Layer. Levelling deposit, seen only in section.		
13925	Layer			0.06	Floor Surface. Soft, dark yellowish grey, Silty sand. Seen in section only.		
13926	Layer			0.2	Occupation Layer. Compact, mid pinkish yellow, sandy silt.	CBM	18th-19thC
13927	Layer			0.08	Floor Surface. Hard, mid yellowish grey, Silty sand. Cobbled surface	Pottery CBM	18th-19thC
13928	Cut		0.8	0.3	Pit. poorly defined pit.		
13929	Fill	13928	0.8	0.3	Secondary Fill. light yellow brown, silty fine sand	Pottery, CBM, Cu Alloy obj	15th-16thC
13930	Unexcavated feature		0.3	0.3	Construction Cut. Vertical sides, fill dark grey brown occasion chalk fragment to 0.01m, only seen in section.		
13931	Unexcavated feature				Other Cut. Layer of strong yellow red, silty sand, probably redeposited natural. Seen only in trench section		



### B.1 Prehistoric pottery

By Alex Davies

#### Introduction

- B.1.1 Some 81 sherds (212g) of prehistoric pottery were recovered from 11 contexts across seven trenches (Table 1). Three periods were represented: the early Neolithic (c 3900-3200 cal BC), probably the late Neolithic (c 2900-2100 cal BC), and the middle Iron Age (c 350-50 cal BC).
- B.1.2 The mean sherd weight of 2.1g is low and suggests that the assemblage is poorly preserved.
- B.1.3 This section does not consider late Iron Age material which follows alongside the Roman material, below.

#### Neolithic

- B.1.4 The pottery in contexts 1904, 1905, 1906, 5104 and possibly 8006 is best dated to the early Neolithic. Each of these contexts produced sherds in poorly sorted flint fabrics, and sherds in sandy fabrics. An incurving rim from a bowl was found in 5104. The persistence of flint being used as a tempering agent throughout most of prehistory in the area makes spot-dating on small assemblages difficult, although the poorly-sorted nature of the flint in these groups as well as the presence of sherds with only sand in the fabric suggests they these belong to the early Neolithic plain bowl tradition. Decoration is absent on all sherds from these deposits. The pottery from context 8006 is very abraded and cannot be closely dated.
- B.1.5 An unusual sherd was found in context 8004. This comprises a rim from an incurving vessel decorated with horizontal furrows/grooves on the outer neck. The fabric contains abundant sand and rare pieces of probable grog. The sherd is not easily paralleled but is best dated to the late Neolithic, belonging to the Grooved Ware tradition. Grooved Ware has been found at nearby Mucking, where grog was by far the dominant temper, although sand was the main inclusion in a smaller number of vessels (Birley 2016). It is also possible that the sherd belongs, instead, to an earliest Iron Age (c 800-550 cal BC) biconical furrowed bowl, although the sherd seems too thick and derived from a larger vessel form.

#### Middle Iron Age

- B.1.6 Contexts 2406 and 12404 produced middle Iron Age pottery, and it is likely that material from 12503 and 12505, and possibly 3703, is also of this date. The most diagnostic sherds were from 12404 and included sherds with glauconitic sand inclusions and another sherd in a sandy fabric that was highly burnished. The inclusion of glauconitic sand becomes widespread during the middle Iron Age across large parts of southern Britain, including at nearby Mucking (Brudenell 2016, 367). The base of a middle Iron Age vessel in a sandy fabric was found in 2406. Contexts 12503 and 12505 did not produce diagnostic material, both yielding sherds in flint fabrics as well as sandy fabrics. The presence of sandy fabrics suggests a middle Iron Age date.

Context	Sherds	Weight (g)	Spot-date	Date (BC)	Fabric	Comment
1904	6	14	E Neo?	3900-3200	Flint; Sand	Poorly sorted
1905	2	9	E Neo?	3900-3200	Flint; Sand	Poorly sorted
1906	3	8	E Neo?	3900-3200	Flint; Sand	Poorly sorted
2406	1	17	MIA	350-50	Sand	
5104	10	19	E Neo	3900-3200	Flint; Sand	Poorly sorted. Incurving rim
3703	4	9	LBA/IA	1150-50	Flint (fine)	Fine
8004	12	24	L Neo?	2900-2100	Sand, grog	Incurving rim, furrow decoration. Unusual
8006	5	4	E Neo or LBA/IA	3900-3200/ 1150-50	Flint	Very abraded small sherds
12404	6	13	MIA	350-50	Sand; Flint	Glauconitic sand. Burnishing
12503	16	27	MIA?	350-50	Sand; Flint	
12505	16	27	MIA?	350-50	Sand; Flint	
<b>TOTAL</b>	<b>81</b>	<b>171</b>				

Table 1: Summary of the prehistoric pottery

## B.2 Late Iron Age and Roman Pottery

By Kate Brady

### Introduction and methodology

- B.2.1 Some 85 sherds of pottery, weighing 218g, were recovered from the evaluation. The assemblage was scanned to identify diagnostic forms and fabrics, provide spot-dates and generally characterise the material. Roman pottery fabrics were assigned codes from OA's standard recording system for material of that date (Booth 2016). Forms identified by rim were given codes from OA's system.
- B.2.2 The Roman pottery was recovered from a single deposit (3707) and was quantified by sherd count and weight (g), and the single rim present was additionally quantified by estimated vessel equivalent (EVE), which measures the percentage of rim circumference that survives (thus, 0.3 equals 30%). The total was 0.07 EVEs from 1 vessel identified by rim (MV). Pottery data by context is provided in Table 2.
- B.2.3 The following late Iron Age and Roman fabric was noted:
- O20 Sandy oxidised ware
- B.2.4 The following form identified by rim was recorded:
- CH Bead-rimmed jar

### Description

Context	Count	Weight (g)	MV	EVE	Spot date	Comments
3707	85	218	1	0.07	40-150	Bead rim jar (CH) in medium to fine sandy oxidised ware (O20)

Table 2: Summary and quantification of the pottery by context (Key: EVE estimated vessel equivalent; MV minimum number of vessels)

### Roman

- B.2.5 The Roman pottery was recovered from Trench 37 and appears to be from a single bead rim jar in medium to fine oxidised ware. A small portion of the rim is present along with part of the footring base and small body sherds. The vessel is a bead-rimmed jar, probably dating to the 1st to mid-2nd century AD.
- B.2.6 The fabric is micaceous and likely to be local in origin. Micaceous clays are available in the local geology for example, the Thanet formation which is glauconitic (BGS 2020).

## B.3 Medieval and Post-medieval Pottery

By John Cotter

### Introduction and methodology

- B.3.1 Seven sherds of medieval and post-medieval pottery weighing 235g were recovered from four contexts. Ordinary domestic wares were recovered. Given the small amount this has not been separately catalogued but is fully described below.
- B.3.2 The context spot-date is the date-bracket during which the latest pottery types or fabrics are estimated to have been produced or were in general circulation. Comments on the range of fabrics were recorded, usually with mention of vessel form (jugs, bowls etc.) and any other attributes worthy of note (e.g. decoration). Fabric codes referred to are those of the Museum of London (MOLA 2014).

### Description

- B.3.3 **Context 6604 c 1820-1850.** 1 sherd (2g). A small abraded body sherd possibly from a dish or bowl in Staffordshire-type transfer-printed ware (Fabric code: TPW). Traces of blue Chinese-style 'willow pattern' decoration on one side and floral decoration on the other. Thin-wall suggesting a fairly early 19th-century date. From Sieved Sample <6>.
- B.3.4 **Context 13919 c 1750-1850.** 2 sherds (221g). From two separate vessels in post-medieval red earthenware (Fabric code: PMR). Fairly fresh condition but some chipping/abrasion. The largest sherd is from the rim of a very wide bowl with a broad horizontal flanged rim and an all-over internal clear orange-brown glaze. The smaller piece, in a similar fabric, is from the base of a dish/bowl form with a convex or sagging base and a bright orange-brown glaze all-over internally. The fabric, and the sagging base (unusual on post-medieval redwares), is similar to 'developed' redwares made at Woolwich in the 18th and 19th centuries.
- B.3.5 **Context 13927 c 1750-1900.** 1 sherd (7g). Rim from a small jar in post-medieval red earthenware (Fabric code: PMR). Fairly fresh condition. Sub-collared rim. Smooth, red flowerpot-type fabric with a dark brown glaze internally.
- B.3.6 **Context 13929 c 1480-1600.** 3 sherds (5g). Three very small body sherds from three separate vessels - probably jugs. The largest of these is a sherd of Mill Green ware (Fabric code: MG), a fine sandy medieval redware dating to c 1270-1350. The latter has traces of white slip decoration under a glossy clear glaze showing dark brown. The other two, smaller, body sherds are in a similar but sandier unglazed redware fabric which may be a later development of Mill Green ware, but more closely resemble London area early post-medieval redwares (PMRE, c 1480-1600). However, it is not impossible that these two sherds could be slightly earlier, but they are too small to be certain.

## B.4 Fired clay

By Cynthia Poole

- B.4.1 A small quantity of fired clay was recovered from Trenches 36 and 112. The material from context 11206 was recovered by hand excavation and that from 3607 from a sieved sample. In view of the small amount, the fired clay is recorded in Table 3.
- B.4.2 All the fragments are amorphous and of indeterminate form and function. None can be dated, and the material is reliant for phasing on any associated dateable artefacts. The material is not heavily fired and is most likely to derive from oven or hearth structure of a domestic nature.

Context	Spot date	Nos	Wt g	Form	Description
11206	U	8	95	Indet	Amorphous. Orange red laminated clay with cream-buff streaks, fine sandy micaceous clay with sparse coarse quartz sand and diffuse red ferruginous pellets. Fragments 1-55mm in size.
3607 <11>	U	45	136	Indet	Amorphous rounded lumps. Orange, pink, light brown, grey fine silty clay, rather powdery, with diffuse reddish clay pellets.

Table 3: Record of fired clay assemblage

## B.5 Ceramic Building Materials

By John Cotter

### Introduction and methodology

- B.5.1 The site produced a total of 94 pieces of ceramic building material (CBM) weighing 7348g from 14 contexts. With the exception of material from a single context, the assemblage is probably confined to the (late?) 18th, 19th and 20th centuries. One context produced a significant quantity of medieval and early post-medieval material. The assemblage is in a fragmentary condition, but some large and fresh pieces are present.
- B.5.2 All the CBM was scanned during the present assessment, and approximate spot-dates were provided for each context. Each context group was quantified by fragment count (or pieces) and weight and recorded on a spot-dating spreadsheet. The material is summarised in Table 4.

### Description

Context	Spot-date	No.	Weight (g)	Comments
2404	18-19C?	2	26	Worn frags probably from the same gently curved tile (pan-tile?) in a smooth late-looking light orange fabric
7606	18-19C?	1	91	Fresh corner frag from a flat roof tile (peg tile?). Fairly crude/handmade. Max 9mm thick. Fairly smooth light orange fabric with rare rounded white calcareous inclusions up to 4mm across. Underside unsanded. 17-19C range possible but probably 18-19C rather than earlier?
13803	18-19C?	10	1082	3x fairly fresh edge frags (263g) of flat roof-tile in similar smooth light orange fabric, unsanded underside, probably 18-19C? 7x frags unfrogged orange-red house brick. The latter include 2 neatly-made corner and edge frags in similar fairly smooth fabric, 1 = 57mm thick, the other = 54mm thick - both probably 18/early 19C (the corner frag is scorched grey or over-fired along one side - possibly from a hearth?). Smaller 'rubble' frags of similar brick
13807	L19-20C	8	3409	1x flat slab-like frag of black granular tarmac road surface max 27mm thick (weight 295g) L19-20C (more likely 20C?). 1x long-edge frag from a curved red pan-tile in a late-looking hard, smooth, red fabric (209g), with specks of black tar or bitumen, probably L19-20C. 6x frags of brick including large end-frags of 2 London-type stock-bricks with shallow frogs in upper surface (both broadly 19C), both in a very coarse orange-yellow fabric with cinders, laminated yellow clay-like inclusions and organic voids. Larger end-frag measures 68mm thick x 110mm wide. Also 1 large frag of dark orange-red 19C house brick (unfrogged, 65mm thick x 108mm wide). Smaller frags of brick including an abraded end-frag (65mm thick) in finer purplish-brown fabric - possibly L18-19C? Also 1 small abraded/rounded brick in fine light orange fabric (16-19C?)

Context	Spot-date	No.	Weight (g)	Comments
13809	L19-20C	3	153	Nb. Finds label with uncertain number - probably 13809 but might be 13804? 3x fresh frags of hard orange flat roof tile. The largest and smallest pieces (body frags) in a very smooth modern-looking fabric and with large patches of bitumen-like material and associated staining - probably L19-20C and most likely 20C? 1x smaller edge frag in sandier peg-tile fabric
13810	19-20C?	1	60	Very fresh body frag from a flat roof tile (peg-tile?) in smooth, late-looking light orange fabric. Underside unsanded
13812	19-20C?	1	3	Surface flake late-looking light orange flat roof tile (or brick?)
13905	L19-20C?	3	116	1x body frag from a brown salt-glazed stoneware drainpipe (or service pipe) with parallel ridging or grooving (for anchoring into mortar/cement); very late-looking yellow fabric and glaze - probably L19-20C? 1x fresh edge frag 19-20C orange peg-tile. 1x abraded scrap of 18-19C stock brick
13917	18-19C?	5	216	Flat roof tile frags. The 2 freshest and latest-looking pieces in a smooth light orange fabric. One of the latter two appears to be from a gently curving edge - possibly giving a rounded or scale-shaped lower end - for decorative purposes? The other 3 frags are more abraded and spalled and in a duller, sandier orange-brown fabric with a grey core - possibly late medieval or early post-medieval (14-16C?)? One of the latter frags is a peg-tile with traces of a circular nail hole
13919	18-19C?	2	784	1x fresh corner frag of peg-tile with a circular nail hole; hard smooth late-looking light-orange fabric (similar to that in 7606), underside unsanded. 1x complete end-frag of reddish-purple house brick, unfrosted, fairly crudely handmade and with early-style vegetation impressions underside; thickness 55-58mm, width 110mm, a few coarse flint inclusions, probably L16-17C?
13921	18-19C?	5	226	Fresh and some abraded/spalled frags of flat roof tile in late-looking light orange fabric. Includes a corner frag and some edge frags. One small piece has specks of accidental glaze and may be from an earlier tile?
13926	18-19C?	3	192	Fresh joining frags from the top-left corner of a peg-tile with a circular nail hole. Smooth light-orange fabric. Late-looking - 18-19C or possibly 19C?
13927	18-19C?	3	38	Fresh scraps of late-looking smooth light orange flat roof tile (2 joining)
13929	15-16C?	47	952	Flat roof tile including a few peg-tiles (with circular nail holes). All in oxidised orange-red to orange-brown fabrics. Around 10 larger frags in the 55-135mm size range including edge and corner frags. The bulk are just small scraps and flakes of tile. These appear to be a mixture of late medieval

Context	Spot-date	No.	Weight (g)	Comments
				and early post-medieval peg-tiles. A few pieces have a very smooth light orange to orange-brown post-medieval looking fabric but the thickness (up to 15mm) and crudeness of manufacture of these could be as early as the (late?) 15-16C? Many of the smaller pieces are almost certainly medieval - these mostly have a fairly smooth brown to orange-brown fabric (sometimes lumpy) with a thin grey core; some have medieval-looking conical-section nail holes and some are rough and sanded on the underside; some pieces are unusually thin - only 9-10mm thick, but most are thicker. The medieval roof tile could include pieces as early as the 13-14C?
<b>TOTAL</b>		<b>94</b>	<b>7348</b>	

Table 4: Description of CBM by context

## Discussion

- B.5.3 The CBM assemblage mostly comprises pieces of flat roof tile (peg-tile) and brick. In 13 of the 14 contexts, the CBM dates from the (late?)18th, 19th and 20th centuries, but mainly, perhaps, from the 19th century. There are also one or two pieces of pan-tile of similar date, and one piece each of brown stoneware drainpipe and of black tarmac (road surface), both dating from the late 19th or 20th century. While the brick assemblage is mainly 19th century, it includes at least one handmade brick-end of earlier date (possibly late 16th/17th century), although this was recovered from a later context (13919). The date exception within this assemblage is context 13929, which comprises 47 pieces of flat roof tile or peg-tile – many surviving as small scraps or flakes. The largest and latest-looking pieces in this context may be of late medieval or early post-medieval date (15th-16th century). This individual assemblage includes numerous pieces of medieval peg-tile which could date to the 13th or 14th centuries.



## B.6 Clay Pipe

By John Cotter

### Introduction and methodology

- B.6.1 Three pieces of clay pipe weighing 6g were recovered from two contexts. This assemblage is fully described below.
- B.6.2 For the London area, pipe bowls are assigned form codes based on Atkinson and Oswald's (1969) London pipes typology with bowl types assigned to an abbreviated code (e.g. AO22).

### Description

- B.6.3 **Context 1309 c 1680-1710.** 1 piece (4g). A broken and very abraded fragment from the back of a pipe bowl of later 17th- or early 18th-century style. The back profile survives with the stub of the stem and part of a very abraded heel (probably a broad circular heel). Below the rim is a faint row of milling - a type of decoration which disappeared on English pipes around c 1730. The stem bore diameter is relatively small (c 2.5mm) which also fits with the dating suggested here. The most probable match is with London types AO20-21 that were both in use c 1680-1710.
- B.6.4 **Context 13921 c 1840-1880.** 2 pieces (2g). Fresh joining rim sherds from the back of a miniature pipe bowl of London-type AO32. This type is occasionally found in London and is a much smaller version of the standard 19th-century spurred pipe bowl AO28 (Atkinson and Oswald 1969, 179). The piece here has a very thin wall and the back mould-seam has moulded acorn or oakleaf decoration (unclear). There is some greyish discolouration internally near the rim, and externally, which might be evidence of use (smoking). Alternatively, this might be a child's bubble pipe, and the discolouration perhaps acquired after deposition.

## B.7 Metal and glass

By Ian R Scott

- B.7.1 Six metal finds from four contexts were recovered during the course of the evaluation.
- B.7.2 They include two fragments from a vessel formed from thin sheet iron from context 9911. These could be from small oil lamp or something similar. They are almost certainly later 19th century or later in date.
- B.7.3 Context 13807 produced three objects. They include a cast iron tine from mechanical mower or reaper, which is most likely to date to the 20th-century. In addition, this context produced a nail and a fragment of iron bar or nail stem.
- B.7.4 Context 13812 produced an incomplete nail, which cannot be closely dated.
- B.7.5 Context 13929 produced a single copper alloy dress pin of late medieval or post-medieval date.

Context	Item no.	Description
9911	(1)	Vessel. Fragments from a vessel formed from thin sheet iron. Two fragments. (1) One fragment possibly from the base of the vessel is formed from two pieces joined by a rolled seam (36mm x 24mm); (2) the second smaller fragment has a rolled lip or edge (c 30mm x 20mm).
13807	(2)	Reaper or mower tine. Cast iron tine from a mechanical reaper or mower. L: 170mm; W: 80mm.
	(3)	Nail with small square domed head, and rectangular section stem. Fe. L: 67mm
	(4)	Bar or nail stem, square section. Fe. Not measured.
13812	(5)	Nail with small square domed head, and square section stem incomplete. Fe. Not measured
13929	(6)	Small dress pin with small spherical head, probably moulded. Cu alloy. L: 24mm.

Table 5: Description of metal objects by context

## B.8 Flint

By Michael Donnelly

### Introduction and methodology

- B.8.1 A moderate assemblage of 145 struck flints and 1663 fragments of burnt unworked flint weighing 5536g was recovered from the evaluation (Table 6).
- B.8.2 The artefacts were catalogued according to OA South's standard system of broad artefact/debitage type (Anderson-Whymark 2013; Bradley 1999), general condition noted and dating was attempted where possible. The assemblage was catalogued directly onto a spreadsheet. Additional information on condition (rolled, abraded, fresh and degree of cortication), and state of the artefact (burnt, broken, or visibly utilised) was also recorded. Retouched pieces were classified according to standard morphological descriptions (e.g. Bamford 1985, 72-77; Healy 1988, 48-9; Bradley 1999). Technological attribute analysis was initially undertaken and included the recording of butt and termination type (Inizan et al. 1999), flake type (Harding 1990), hammer mode (Onhuma and Bergman 1982), and the presence of platform edge abrasion.

### Assemblage description

- B.8.3 The struck flint was widely dispersed across the evaluation area with often only a single flint from any context but there were several contexts that yielded more than five flints including one assemblage of 55 pieces from an early Neolithic pit. Four of the larger assemblage were topsoil groups in the vicinity of Trenches 122 to 138. With the exception of pit 5103 and a few other tools types, the majority of the flintwork was undiagnostic, although there was a clear focus on flake production. It is likely that much of the dispersed assemblage belongs to either the late Neolithic or Bronze Age while the key secure assemblage dated to the early Neolithic.

Category type	Number
Flake	87
Blade	4
Bladelet	5
Blade index	9.38% (9/96)
Irregular waste	8
Janus flake	1
Chip	1
Sieved chip 10-2mm	8
Core single platform flakes	1
Core multi-platform flakes	1
Core levallois non-discoidal flakes	2
Core fragment	1
Scraper end	5
Scraper side and end	2
Arrowhead unclassified	1
Piercer	1
Ground implement flake	2
Microdenticulate	5
Denticulate	1
Notch	1
Backed knife	1
Retouched flake	3
Retouched other	4
<b>Total</b>	<b>145</b>

Burnt unworked	1663/5536g
No. burnt (%)	5/145 (3.45%)
No. broken (%)	32/145 (22.07%)
No. retouched (%)	26/145 (17.93%)

Table 6: Summary and quantification of the flint by type

### Provenance

B.8.4 A significant proportion of the flints were topsoil finds (42.07%, 61/145) but the largest fraction came from pit fills with 68 flints (46.90%) (Table 7). Ditch fills accounted for 14 more flints (9.65%) and there were two from colluvial layers (1.38%). However, figure for pits is misleading as the greater part of this assemblage (55 flints with 20 of these recovered from a sample) derived from the fills of a single feature (5103). A further 10 flints were recovered from a sample from pit 1903 (fill 1904) with another flint coming from its primary fill (1906). Two more pits contained just single examples including one from pit 5206 close to the Neolithic pit (5104).

Category type	Total	Percentage
Pits	68	46.90
Topsoil	61	42.07
Ditches	14	9.65
Colluvium	1	1.38
<b>Total</b>	<b>255</b>	<b>[100]</b>

Table 7: The flint assemblage by context type

B.8.5 The topsoil material found around Trenches 122 to 138 included additional surface finds identified during a brief field walk that were assigned to the closest trench. This was in close proximity to a scheduled causewayed enclosure positioned on high ground overlooking the evaluation area from the north.

B.8.6 Burnt unworked material was almost wholly recovered from pit 11504 with an estimated 1650 fragments (99.20%) weighing 5517g (99.66% by weight). Treethrow 6604 contained 10 pieces weighing 14g and there was only one other context with burnt unworked material, fill 2503 from pit 2502.

### Raw material and condition

B.8.7 Flint was the sole material represented here and came with a wide variety of cortical states indicating a range of sources was exploited. Thin, granular or abraded cortex typical of some North Downs material was found on 41 of the 76 cortical pieces accounting for 53.94%. This was followed by more typical chalk cortex found on 18 examples (23.68%), 10 of which were heavily weathered indicating a secondary source (13.16%). Bullhead Bed material accounted for seven examples (9.21%) and was followed by limited amounts displaying rolled/gravel (6.58%, 5/76), thermal (3.95%, 3/76) and polished/ground (2.63%, 2/76).

B.8.8 The flints were either fresh (66/131, 50.38%) or lightly edge damaged (45/131, 34.35%) with 10 pieces displaying moderate (7.63%) levels of edge damage, two with heavier edge damage (1.53%), and eight that were clearly plough damaged (6.11%).

B.8.9 Cortication was largely light (108/131, 82.44%) with lesser amounts displaying moderate (10/131, 7.63%) or no cortication (9/131, 6.87 %). One piece that displayed iron staining (1.76%) represented a small levallois style core and could, theoretically, be very old in date, possible middle Palaeolithic. Overall, the condition of the material suggests an assemblage that includes lightly disturbed pieces alongside several large in situ assemblages from the key feature groups, most likely being contemporary within these features. These occurred alongside some heavier damaged pieces associated with the ploughzone especially in the vicinity of Trenches 122-139.

## Discussion

- B.8.10 Early Neolithic pit 5104 yielded the most important artefact group and amounted to a significant proportion of the total assemblage (37.93%). This contained a flake-heavy assemblage of 32 flakes, six blade forms and numerous tools. The single core was very close to a levallois form but may have been another form of complex flake core. Tools included two microdenticulates on blade blanks and a third combined with an end scraper on another blade. A retouched flake, a denticulate and a flake from a ground/polished object completed the tool inventory giving the pit a very high percentage (12%) of retouched artefacts. Several of the tools, including the microdenticulates, had clear signs of having been utilised.
- B.8.11 Broken pieces amounted to 30% of the assemblage while just 2% were burnt. Overall, this looks like the deposition of knapping waste and utilised tools and cores, possibly from a surface midden. The fine fraction residue from the samples has not been scanned for micro debitage so it is not possible to say if any of this was knapped into the pit or collected from surface deposits after knapping and use.
- B.8.12 Ploughzone material recovered from the area closest to the causewayed enclosure amounted to 40 pieces and was very heavily focused on flake production with just one blade amongst 29 flake blanks (3.33%). A core fragment was also geared towards flake reduction. However, two of the five tools identified (12.5%) were fashioned on blades and comprised a microdenticulate and an end of blade scraper both of which could easily date to the early Neolithic period. The remaining three tools included another flake from a ground/polished object and two end of flake scrapers, one of which looked to be later prehistoric in date.
- B.8.13 A significant proportion of the remaining debitage, cores and tools were typical of later prehistoric knapping, although an early Bronze Age date for some could also be possible. This material was widely dispersed over numerous contexts.
- B.8.14 This evaluation has generated a relatively significant flint assemblage and suggests that any further works here could encounter dense concentrations of flintwork. This could include pit clusters suggested by the pair of pits in Trench 51. Neolithic activity represented by pits can often be found in close proximity to larger monuments such as causewayed enclosures.

## B.9 Stone

By Ruth Shaffrey

- B.9.1 Two pieces of stone were recovered during the course of the evaluation.
- B.9.2 A flint nodule with coarse battering damage at one end was recovered from context 5104 (431g, >82 x 72 x 54mm). The impact damage indicates that this was utilised as a hammerstone. The rest of the nodule retains its cortex. This was recovered from context 5104 (431g, >82 x 72 x 54mm), a fill of an early Neolithic pit.
- B.9.3 A large nodule of flint that has been roughly shaped for use in construction was recovered from a wall recorded in Trench 138 (13803, 743g, 120 x 88 x 67mm). This retains mortar on two surfaces. The wall is likely to be related to the historic Seaborough Hall.

### C.1 Environmental Samples

By Richard Palmer

#### Introduction

- C.1.1 Twelve samples were recovered during the course of the evaluation, primarily for the retrieval and assessment of Charred Plant Remains (CPR) and the recovery of bones and artefacts.

#### Method

- C.1.2 The samples were processed in their entirety at Oxford Archaeology using a modified Siraf-type water flotation machine. The flots were collected in a 250µm mesh and heavy residues in a 500µm mesh and dried. The residue fractions were sorted by eye and with the aid of a magnet while the flot material was sorted using a low power (x10) binocular microscope to extract cereal grains and chaff, smaller seeds and other quantifiable remains.

#### Results

- C.1.3 A summary of the samples and flot assessment is presented in Table 8.
- C.1.4 **Trench 19.** Sample 5 was recovered from deposit 1904, the fill of a pit (1903) dated to the early Neolithic. Recovered material is limited with most charcoal having at least one plane <2mm. A single fragment of hazelnut (*Corylus avellana*) was recovered along with several goosefoot seeds (*Chenopodium* sp.) which had a mix of both charred and modern specimens. Some flint was recovered from the residue.
- C.1.5 **Trench 25.** Sample 1 is from fill 2503 of pit 2502. Recovered charcoal is in good condition with some fragments being diffuse porous. The weed seed assemblage primarily comprises goosefoot (*Chenopodium* sp.), most of which appears to be charred. A single glume was recovered with characteristics of spelt (*Triticum spelta*) but more specimens would be required to form an interpretation.
- C.1.6 **Trench 36.** Sample 11 is from fill 3607 of pit 3606. The flot almost entirely consist of charcoal. This is preserved in a good condition with several ring porous fragments present. The burrowing snail *Cecilioides acicula* is present but has not been quantified. Fired clay was recovered from the residue.
- C.1.7 **Trench 51.** Sample 2 is from fill 5104 of pit 5103 and has an early Neolithic spot date. Recovered charcoal >2mm was mostly at the smaller end of this spectrum posing possible issues for further identification work. An assemblage of 39 hazelnut fragments (*Corylus avellana*) >2mm was recorded with more possible below 2mm. The single recovered grain was too damaged for identification. Identified weed seeds were limited to goosefoot (*Chenopodium* sp.) and most are charred although modern specimens were observed. Pottery and flint were recovered from the residue.
- C.1.8 Sample 3 is from fill 5106 of pit 5105. Many of the charcoal fragments have at least one plane <2mm. A grain of wheat (*Triticum* sp.) was identified in poor condition. A small legume and goosefoot seeds (*Chenopodium* sp.) were also identified. Most goosefoot

seeds were uncharred and so likely to be modern but charred specimens were also present. No organic remains or artefacts were recovered from the residue.

- C.1.9 **Trench 52.** Sample 4 is from fill 5206 of pit 5205. No charred material >4mm was recovered and the burrowing snail *Cecilioides acicula* is present in the flot. No organic material or artefacts were recovered from the residue.
- C.1.10 **Trench 66.** Sample 6 is from fill 6604 of tree throw 6603 from which a fragment of post-medieval pottery was recovered. A large quantity of charcoal comprises over twenty-five fragments >4mm and some fragments >10mm. A single grain wheat (*Triticum* sp.) is present in poor condition. Burnt flint was recovered alongside the pottery fragment from the residue.
- C.1.11 **Trench 80.** Sample 7 is from fill 8004 of pit 8003 and has a late Neolithic spot date. Limited charred material was recovered from the flot with no material >4mm in size. Flint was recovered from the residue.
- C.1.12 **Trench 107.** Sample 8 is from fill 10704 of tree throw 10703. The flot includes little in the way of charred material with only a single charcoal fragment >2mm. The residue produced no significant remains.
- C.1.13 **Trench 115.** Sample 9 is from fill 11504 of pit 11503. Recovered charcoal is in good condition with at least twenty-five fragments >4mm. The residue was largely composed of burnt flint, and this is considered elsewhere.
- C.1.14 **Trench 121.** Sample 10 is from fill 12103 of ditch 12102. Charcoal in good condition is present but the flot contains little in the way of other charred material. A few flints were recovered from the residue.
- C.1.15 **Trench 133.** Sample 12 is from fill 13304 of tree throw 13303. A little charcoal was recovered from the flot but no organic material or artefacts were recovered from the residue.

## Discussion

- C.1.16 Recovery of charred material on site is limited to charcoal from most features, the majority of which are currently undated. Individual cereal grains have been identified in samples 2, 3 and 6 and nutshell in early Neolithic samples 2 and 5. If securely dated as early Neolithic then the cereal grain is significant, but the possibility of this being intrusive cannot be ruled out. Unfortunately, the individual grains are likely to be of insufficient weight for radiocarbon dating. Samples 1, 2, 9 and 11 do include material likely to be suitable for radiocarbon dating, and a few other samples may include suitable material.

### *Early Neolithic*

- C.1.17 Two samples come from deposits with early Neolithic dates. Hazelnut (*Corylus avellana*) is present in these samples indicating the exploitation of this resource. Sample 2 also includes an unidentifiable cereal grain, probably too small to radiocarbon date, but although potentially significant as evidence of early agricultural activity the possibility this is intrusive must be acknowledged.
- C.1.18 Sample 3, whilst currently undated, includes a somewhat similar charred assemblage to that from sample 2, which was taken from a feature in close proximity, so it is possible that these features are of similar date.



C.1.19 Both hazelnut and potentially goosefoot are likely to have been food resources. Fat hen (*Chenopodium album*) is even today sometimes cultivated as a food crop and is likely to have been utilised as food in prehistory. Other chenopods are also edible.

*Late Neolithic*

C.1.20 A single sample is dated as late Neolithic, but the material does not offer much potential for interpretation.

*Post-medieval*

C.1.21 A single sample has a post-medieval spot-date and produced a useful assemblage of charcoal fragments which could allow species identification. As the feature is a tree throw further interpretation is likely to be limited and it must be possible that the pottery is intrusive.

*Undated*

C.1.22 Most of the samples come from currently undated features. Further interpretation of these samples is limited.

Sample no.	Context.	Feature/Depth	Date	Sample vol. (L)	Flot vol. (ml)	Charcoal >2mm	Grain	Chaff	Weeds	Molluscs	Other	Notes
1	2503	2502		20	70	+++		+	+++			7.5YR 4/4 sandy clay. Frequent modern roots.
2	5104	5103	ENeo	10	25	+++	+		++		+++	7.5YR 4/3 silt loam. Some modern roots.
3	5106	5105		20	20	++	+		++		+	10YR 3/4 silt loam. Frequent modern roots.
4	5206	5205		20	10	++						10YR 6/4 sandy silt loam. Mostly modern roots.
5	1904	1903	ENeo	40	15	++			++		+	10YR 4/6 sandy loam. Mostly modern roots.
6	6604	6603	PMed	20	60	++++	+		+	+		10YR 4/6 silt loam. Some modern roots.
7	8004	8003	LNeo	30	20	++			+			10YR 5/4 sandy silt loam. Mostly

Sample no.	Context.	Feature/Deposits	Date	Sample vol. (L)	Flot vol. (ml)	Charcoal >2mm	Grain	Chaff	Weeds	Molluscs	Other	Notes
												modern roots.
8	10704	10703		30	22	+				+		7.5YR 4/6 silt loam. Mostly modern roots.
9	11504	11503		20	80	++++						10YR 2/1 and 10YR 7/6 sandy silt loam. Some modern roots.
10	12103	12102		40	34	++				+		10YR 4/6 sandy loam. Mostly modern roots.
11	3607	3606		40	75	++++			+			10YR 6/4 with 2.5YR 5/8 and Gley 2 8/1 clay loam. Some modern roots.
12	13304	13303		40	10	++				+		7.5YR 4/6 sandy loam. Some modern roots.

Key: +=present (up to 5 items), ++=frequent (5-25), +++=common (25-100), ++++=abundant (100+).

Table 8: Assessment of CPR flots

## C.2 Animal bone

By Rebecca Nicholson Palmer

### Introduction and methodology

- C.2.1 Only four fragments of animal bone were recovered, weighing 45g in total. They were weighed and identified using the comparative osteological collection at Oxford Archaeology.

### Description

- C.2.2 Pit fill 9911, which is probably modern, included a single fragment of a cattle distal femur weighing 35g. Although in fair condition the bone shows evidence of gnawing around the epiphysis.
- C.2.3 Three small fragments of mammal long bone from (2406) weighing 7g are chalky and exhibit some surface erosion.
- C.2.4 A right femur from a medium-sized bird, cf. partridge, in good condition but missing part of the proximal and distal ends, came from context 7606.

## Appendix D      References

---

- Anderson-Whymark, H, 2013, the flint, in Allen, T, Barclay, A, Cromarty, A, M, Anderson-Whymark, H, Parker, A, Robinson, M, and Jones, G, Opening the wood, making the Land; The Archaeology of a Middle Thames Landscape, Mesolithic, Neolithic and Bronze Age, Vol 1, Oxford: Oxford Archaeological Unit. Thames Valley Landscapes Monograph 38
- Atkinson, D, and Oswald, A, 1969 London clay tobacco pipes, *Journal of the British Archaeological Association* 32, 171-227
- Bamford, H., 1985 Briar Hill: excavation 1974-1978, Northampton: Northampton Development Corporation. Archaeological monograph 3
- Birley, M, 2016 Pottery, in C Evans, G Appleby and S Lucy, with J Appleby and M Brudenell Lives in the Land. Mucking Excavations by Margret and Tom Jones, 1965-1978: Prehistoric, Context and Summary, Oxbow Books, 71-7
- Booth, P, 2016 Oxford Archaeology Roman pottery recording system: An introduction, unpublished
- Bradley, P, 1999 The worked flint. In A. Barclay and C. Halpin. Eds. Excavations at Barrow Hills, Radley, Oxfordshire, Oxford: Oxford Archaeological Unit. Thames Valley Landscapes Monograph 11: 211-227.
- British Geological Survey. (2020). *Geology of Britain Viewer*. Retrieved from <http://mapapps.bgs.ac.uk/geologyofbritain/home.html>
- Brudenell, M, 2016 Middle Iron Age Pottery, in C Evans, G Appleby and S Lucy, with J Appleby and M Brudenell Lives in the Land. Mucking Excavations by Margret and Tom Jones, 1965-1978: Prehistoric, Context and Summary, Oxbow Books, 365-93
- Chartered Institute for Archaeologists (CIfA). (2014a). Standard and Guidance for Archaeological Evaluation. Retrieved from: Chartered Institute for Archaeologists (CIfA). (2014a). *Standard and Guidance for Archaeological Evaluation*. Retrieved from:  
<http://archaeologists.net/sites/default/files/node-files/IfASG-Evaluation.pdf>
- Chartered Institute for Archaeologists (CIFA). (2014b). *Standard and Guidance for the Creation, Compilation, Transfer and Deposition of Archaeological Archives*.
- Harding, P, 1990 The worked flint, in The Stonehenge environs project, (ed J C Richards) London, English Heritage
- Healy, F, 1988 The Anglo-Saxon Cemetery at Spong Hill, North Elmham, Part VI: Occupation during the seventh to second Millennia BC, East Anglian Archaeological reports 38
- Hedges, J and Buckley, D. (1978). Excavations at a Neolithic Causewayed Enclosure, Orsett, Essex, 1975. *Proceedings of the Prehistoric Society* 44, 219-308.

- Highways England. (2018). *Lower Thames Crossing: A Scheme Wide Specification for Archaeological Trial Trenching: unpublished document HE540039-CJV-GEN-GEN-SPE-HER-00001draft, Revision 1.05.*
- Historic England. (2015). *Management of Research Projects in the Historic Environment: The MoRPHE Project Managers' Guide.* Swindon: Centre for Archaeology Guidelines.
- Inizan, M.-L, Reduron-Ballinger, M, Roche, H and Tixier, J, 1999 Technology and terminology of knapped stone, Cercle de Recherches et d'Etudes Préhistoriques, CNRS, Nanterre
- Medlycott, M ed. (2011). *Research and Archaeology Revisited: a Revised Framework for the East of England.* East Anglian Archaeology Occasional Paper 24: Association of Local Government Archaeological Officers.
- MOLA 2014, London medieval and post-medieval pottery codes, Museum of London Archaeology, <http://www.mola.org.uk/medieval-and-post-medieval-pottery-codes> (Accessed 11 Jan 2019)
- Onhuma, K and Bergman, C A, 1982 Experimental studies in the determination of flake mode, *Bulletin of the Institute of Archaeology, London* 19, 161-171
- Oxford Archaeology 2019a Lower Thames Crossing, Scheme-wide Written Scheme of Investigation for Trial Trenching south of the River Thames
- Oxford Archaeology 2019b Lower Thames Crossing, Scheme-wide Written Scheme of Investigation for Trial Trenching north of the River Thames
- Oxford Archaeology. (2019c). Lower Thames Crossing Detailed Written Scheme of Investigation for Trial Trenching of Land Parcel 4. Oxford Archaeology.
- PCRG, SGRP, MPRG, 2016 A standard for pottery studies in archaeology, Prehistoric Ceramics Research Group, Study Group for Roman Pottery, and the Medieval Pottery Research Group
- Place Services, 2019 Lower Thames Crossing Aerial Investigation and Mapping Report, Essex County Council
- Thurrock Local History Society, 2019 An occasional blog about Thurrock history and heritage, Seaborough Hall <http://www.thurrock-history.org.uk/blog/?p=282>
- Wilkinson, T. J. (1988). *Archaeology and Environment in South Essex: Rescue Archaeology on the route of the A13 Grays By-pass, 1979/80.* East Anglian Archaeology 42.

# Appendix E      Abbreviations and Glossary

---

**ADS** Archaeology Data Service. Digital archaeological archive

**CDM** Construction Design Manual. Health and safety guidance for the construction industry

**CPD** Continuing Professional Development

**CiFA** Chartered Institute for Archaeologists

**DBA** Desk Based Assessment. Detailed assessment of archaeology and other aspects of the historic environment

**DCO** Development Consent Order

**EIA** Environmental Impact Assessment. Detailed study of environmental impacts as directed under the The Town and Country Planning (Environmental Impact Assessment) Regulations 2017 following on from EU Directive EIA Directive (85/337/EEC)

**ES** Environmental Statement. The principal environmental report detailing environmental impacts within an EIA

**GPS** Global Positioning System

**HER** Historic Environment Record

**LTC** Lower Thames Crossing

**MCiFA** Member of the Chartered Institute for Archaeologists

**MoRPHE** Management of Research Projects in the Historic Environment

**NMP** National Mapping Programme. A study of aerial photographs and digitisation of resulting data into GIS. Originally funded by Historic England

**OASIS** Online Access to the Index of archaeological investigations.

The OASIS project brings together a number of strategic partners: the Archaeology Data Service, Historic England, Historic Environment Scotland, and the Royal Commission on the Ancient and Historical Monuments of Wales under the umbrella of the University of York

**OCN** Old County Number. Historic England's reference for material that is not readily-available online and may represent historic archaeological work that consists of paper archives or has yet to be formally reported on

**PINS** Planning Inspectorate

**RAMS** Risk Assessment Method Statement

**SMC** Scheduled monument consent

**TDR** Trusted Digital Repository

**UKIC** United Kingdom Institute for Conservation

**WSI** Written Project of Investigation. A detailed method statement for archaeological work

**WSL** – Western Southern Link

The Western Southern Link (WSL) is an alternative for Short List Routes 2, 3 and 4 to the south of the River Thames.

## Appendix F Site Summary

---

<b>Site name:</b>	Lower Thames Crossing Land Parcel 4 Old House, Chadwell St Mary, Essex
<b>Site code:</b>	LTC4OH 19
<b>Grid Reference</b>	564996 180073
<b>Type:</b>	Evaluation
<b>Date and duration:</b>	13th to 30th January 2020
<b>Area of Site</b>	21.47ha

### Location of archive:

The archive from Land Parcel 4 will form part of the overall trial trenching scheme archive. This will be deposited in a repository consistent with the standards required by the Museums and Galleries Commission following completion of the archaeological phase of this project. This may either be with the local receiving museum in Thurrock or, if no such repositories are available, with a repository for the whole project designated by LTC. LTC retain the overall responsibility for the successful deposition of the project archive.

Currently, the archive is held at Oxford Archaeology's head office, Janus House, Osney Mead, Oxford, Oxfordshire, OX2 0ES. Oxford Archaeology will store the archive for LTC for a maximum period of 2 years following the completion of the project. If the storage of the archive at OA's office extends past this period, an extension to the storage period and final deposition timetable will be reviewed by OA and LTC and agreed with the major stakeholders.

### Summary of Results:

Oxford Cotswold Archaeology was commissioned by Balfour Beatty to undertake a trial trench evaluation of Land Parcel 4 of the Lower Thames Crossing Pre-Enabling Works. Land Parcel 4, also known as Old House, is located directly north of the suburbs of Chadwell St Mary within the county of Essex and Thurrock unitary authority (NGR TQ 64996 80073). The evaluation comprised 139 trenches and was completed between the 13th and the 30th January 2020.

The majority of the trenches towards the northern edge of the site revealed deep slope deposits marking a roughly NW-SE aligned dry channel. This corresponds with a large linear trend visible on available LiDAR data, which maps a dry valley continuing further east into Land Parcel 5.

Small assemblages of Neolithic material were encountered in Trenches 19 and 51, comprising worked flint, pottery and hazelnut shells. These demonstrate activity over a wide-ranging area that is probably contemporary with the life span of the causewayed enclosure located to the north of the site boundary.

Trenches 24, 124 and 125 included Iron Age remains, although the evidence is relatively sparse and does not suggest any high-level activity within the site.

Evidence for Romano-British remains was confined to Trench 37 at the western edge of the evaluation area. This suggests that the focal point of activity during the Roman period lay further to the west, within the adjacent Land Parcel 3 (Hornsby Lane), where evidence for more complex industrial activity was encountered.

Several NNE-SSW and WNW-ESE-aligned ditches encountered in the western half of the site match the orientations of post-medieval field boundaries marked on 1st Edition Ordnance Survey mapping. In addition, two wall lines and associated features encountered in Trenches 138 and 139 are likely related to the demolished Seaborough Hall. A single pit in Trench 139 provides some evidence for a late medieval presence at Seaborough Hall.



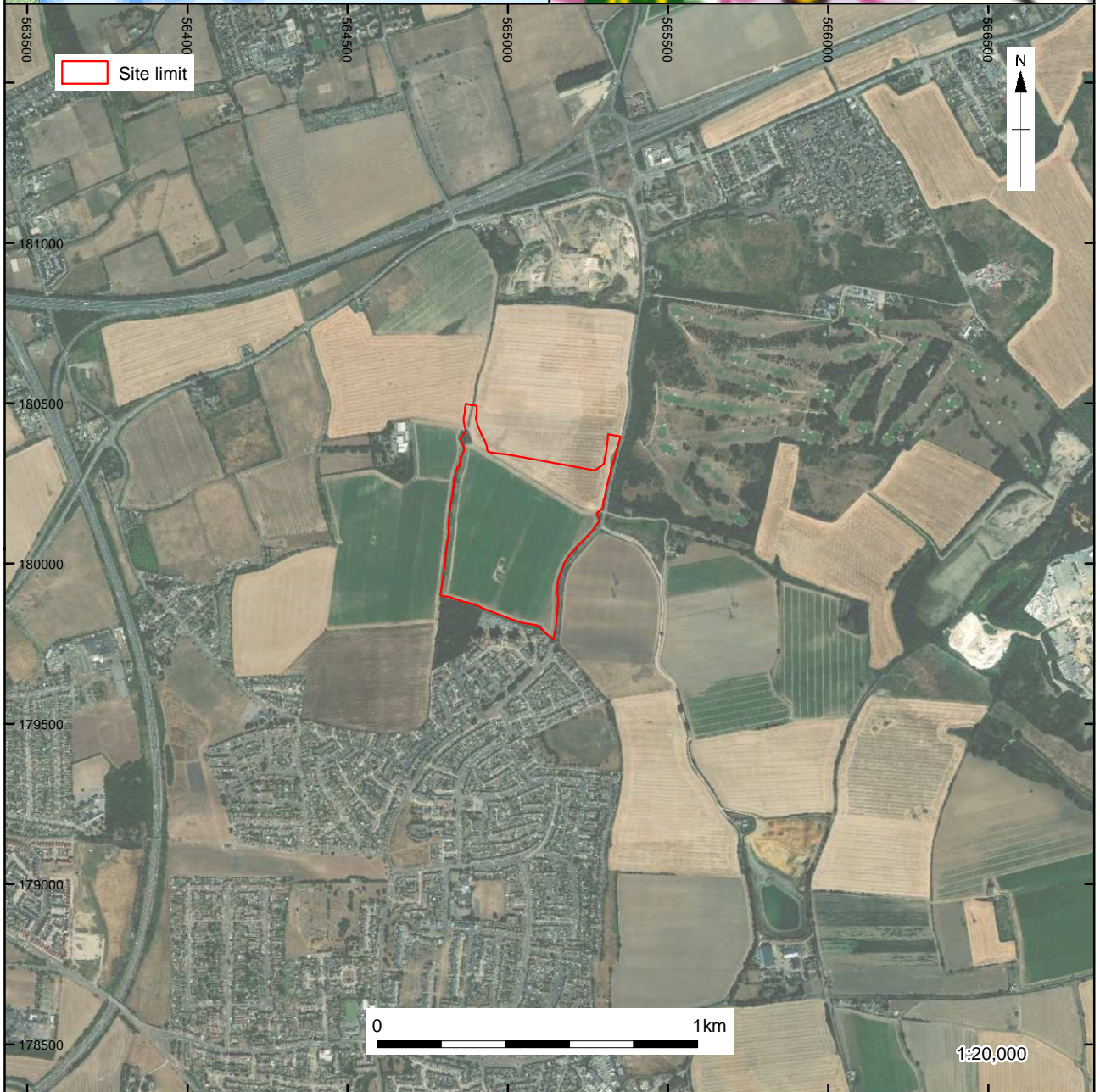
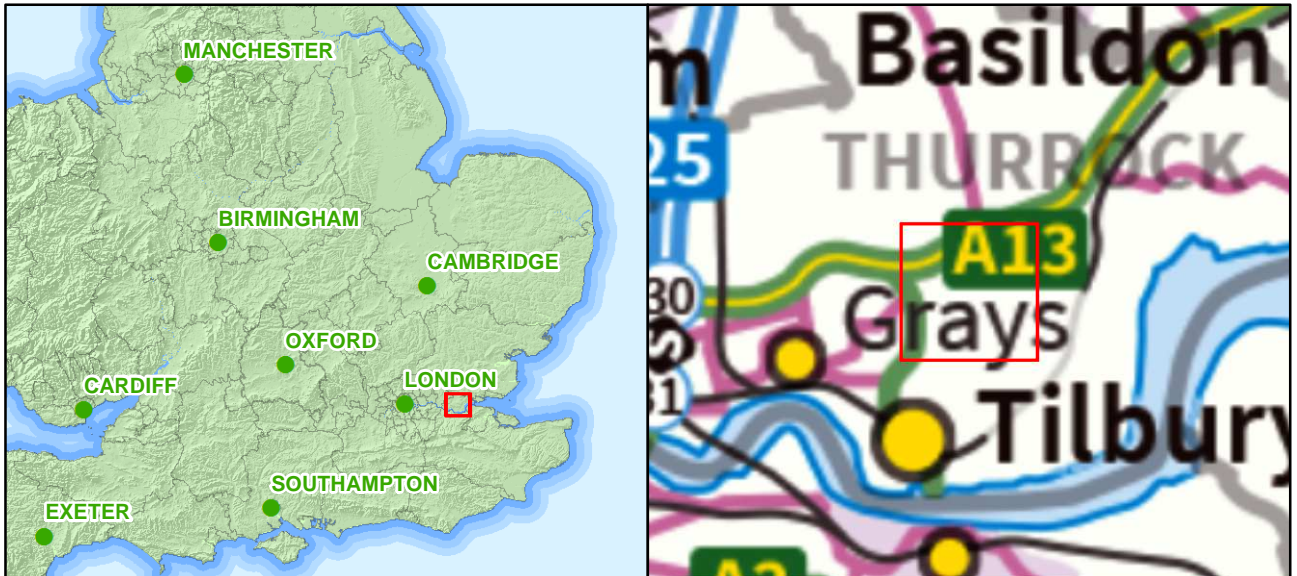

X:\WIL\TOEV\_Lower\_Thames\_Crossing\010\Geomatics\03 GIS Projects - L\TC4OH19\Figures\TC4OH\Fig1.mxd\aidan.faman\*20/02/2020

Contains Ordnance Survey data © Crown copyright and database right 2020

Source: Esri, DigitalGlobe, GeoEye, Earthstar Geographics, CNES/Airbus DS, USDA, USGS, AeroGRID, IGN, and the GIS User Community

Figure 1: Site location

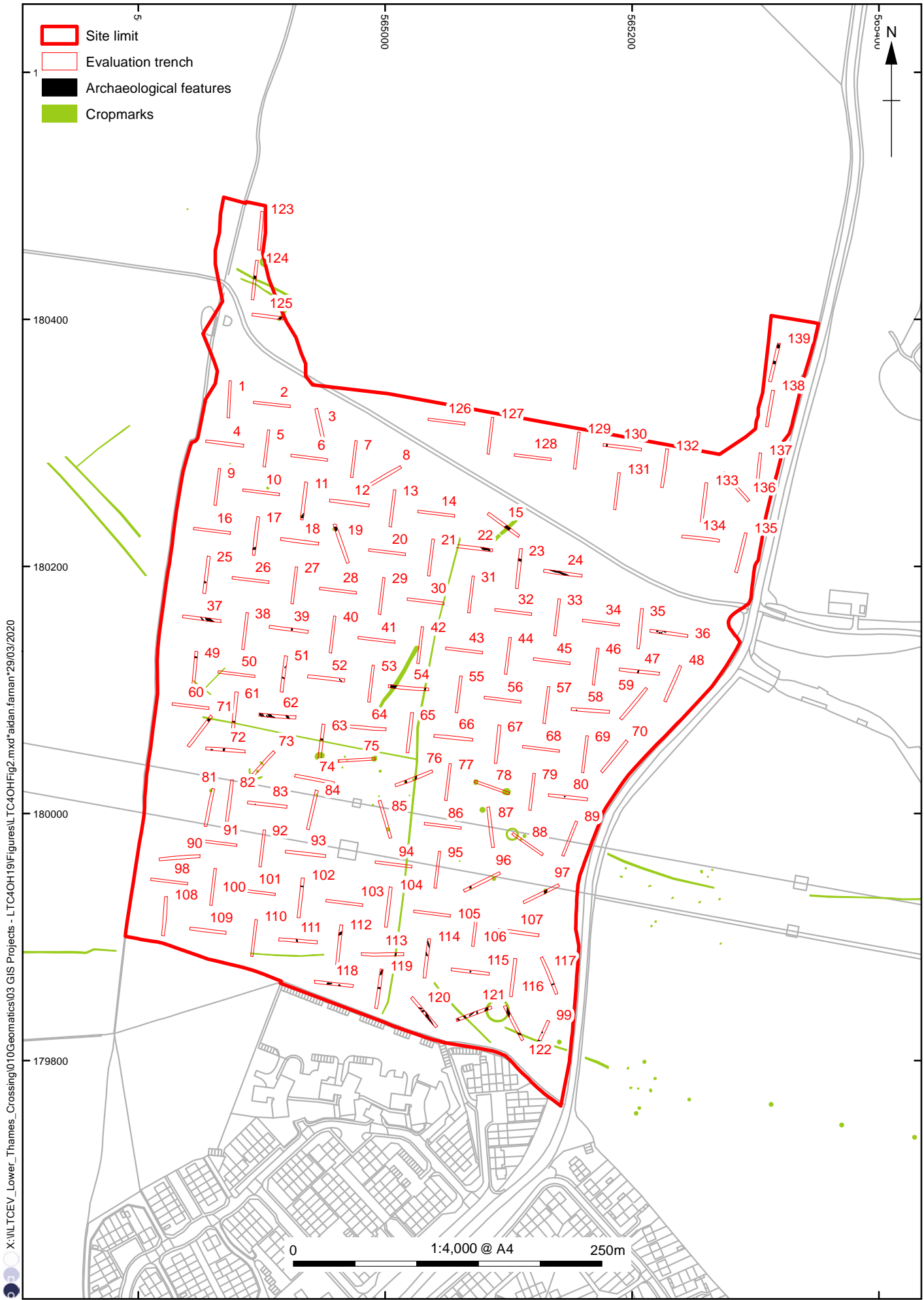
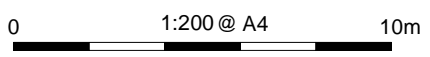
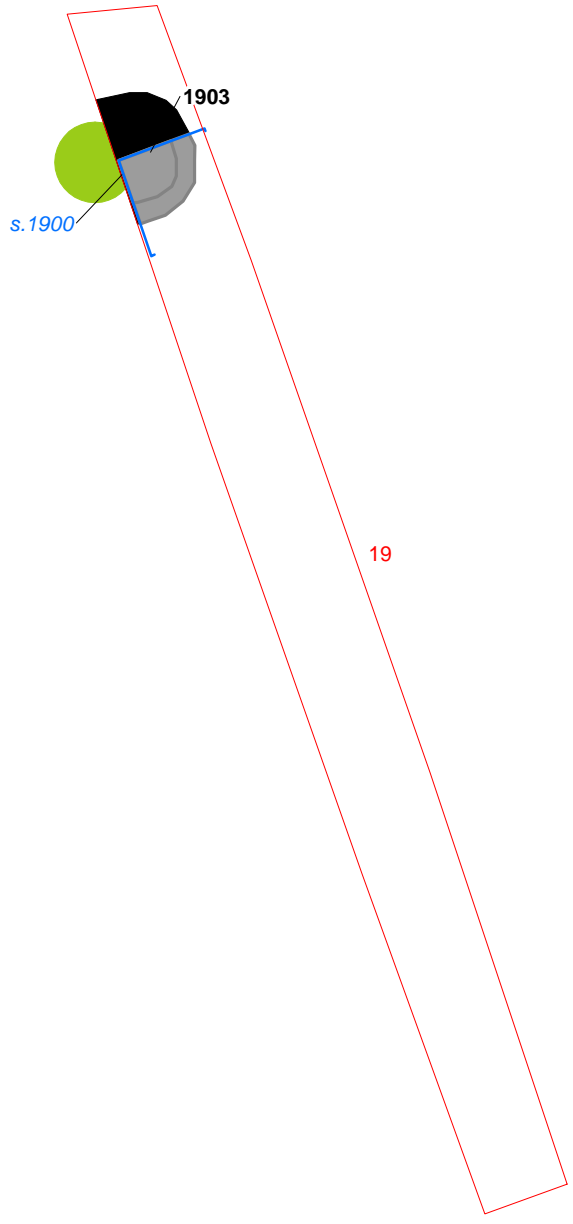
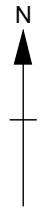

Figure 2: Plan of trench layouts, cropmark features and archaeological features

- Evaluation trench
- Archaeological feature
- Intervention
- Section
- Cropmarks



X:\IL\TCEV\_Lower\_Thames\_Crossing\010\Geomatics\03 GIS Projects - L\TC4OH19\Figures\TC4OHFig3.mxd\aidan.faman\*20/02/2020

Figure 3: Plan of Trench 19

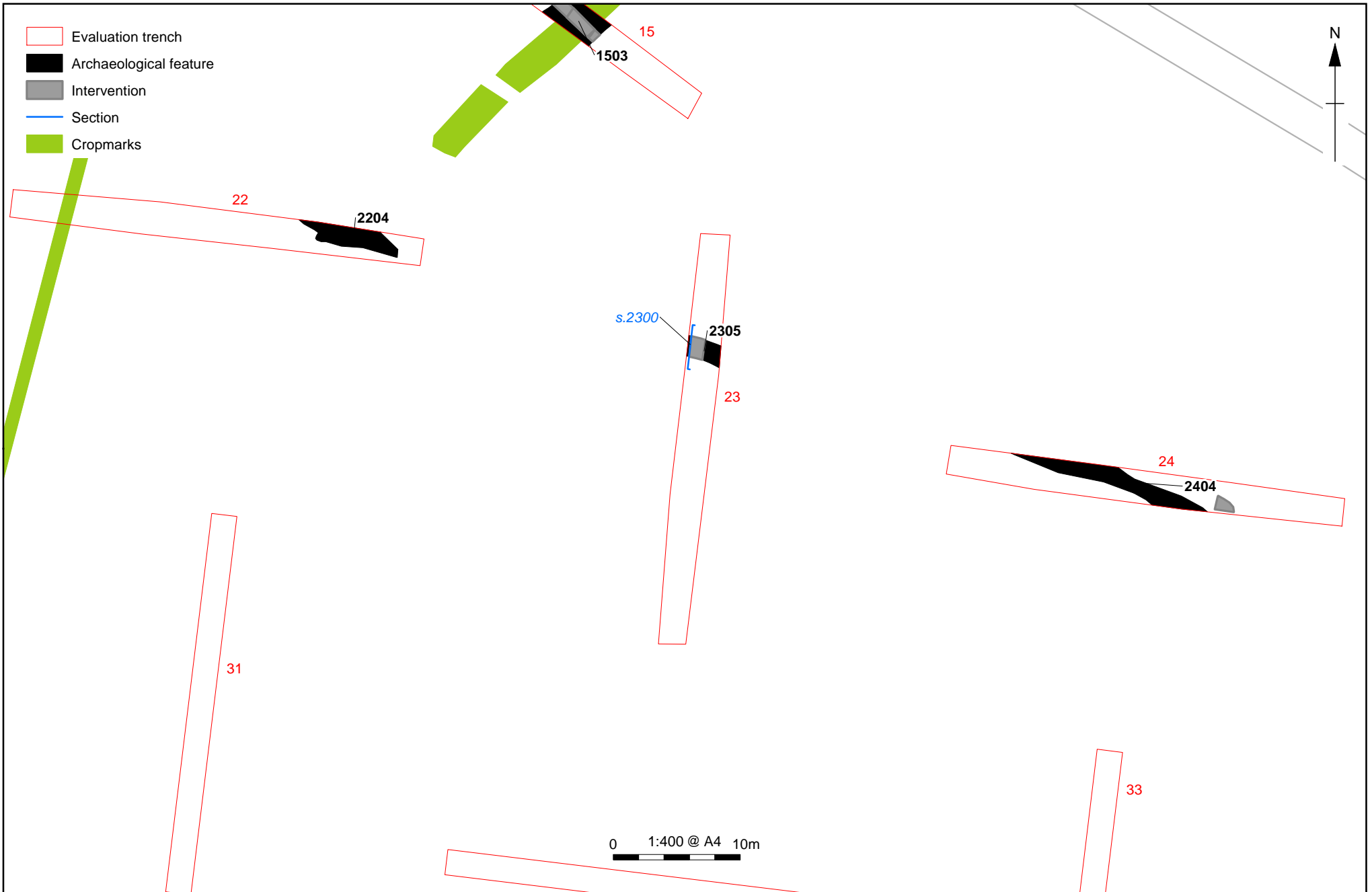



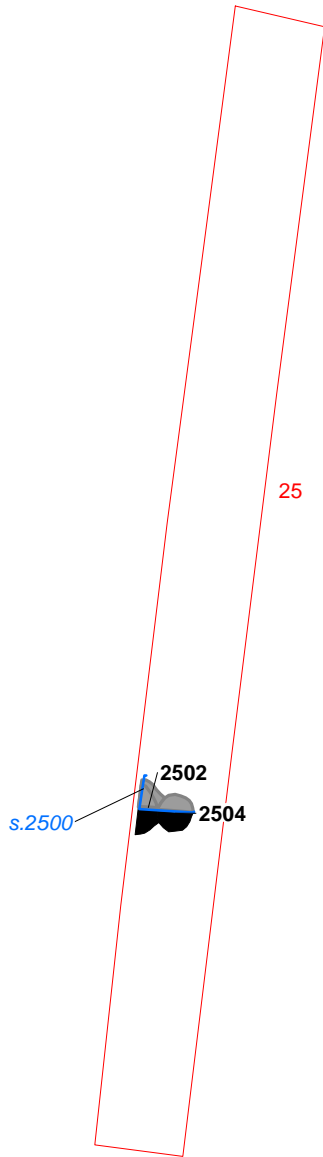
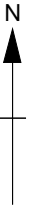

Figure 4: Plan of Trenches 22, 23 and 24

-  Evaluation trench
-  Archaeological feature
-  Intervention
-  Section



0 1:200 @ A4 10m

X:\W\TCEV\_Lower\_Thames\_Crossing\010Geomatics\03 GIS Projects - L\TC4OH19\Figures\TC4OH\Figs.mxd\aidan.faman\*20/02/2020

Figure 5: Plan of Trench 25

- Evaluation trench
- Archaeological feature
- Intervention

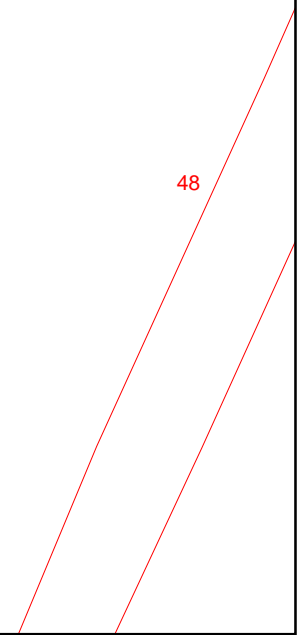
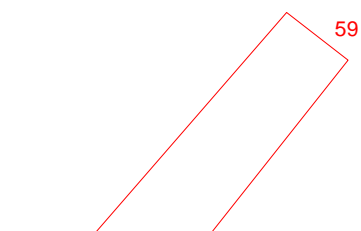
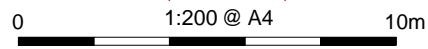
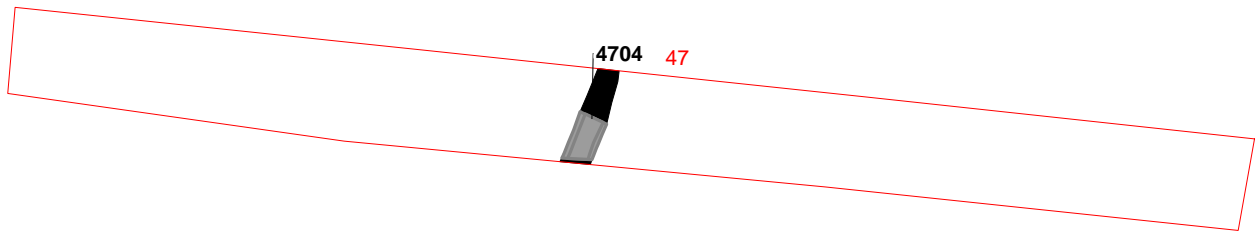
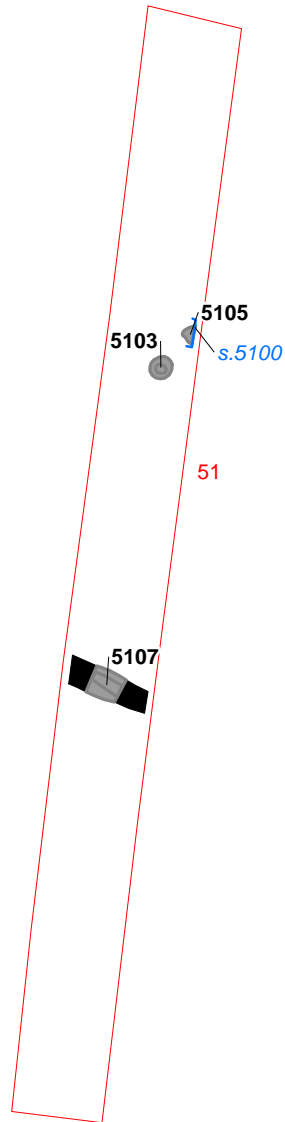

Figure 6: Plan of Trench 47

- Evaluation trench
- Archaeological feature
- Intervention
- Section
- Cropmarks



0 1:200 @ A4 10m

X:\11\TCEV\_Lower\_Thames\_Crossing\010\Geomatics\03 GIS Projects - L\TC4OH19\Figures\TC4OH\Fig7.mxd\aidan.faman\*21/02/2020

Figure 7: Plan of Trench 51

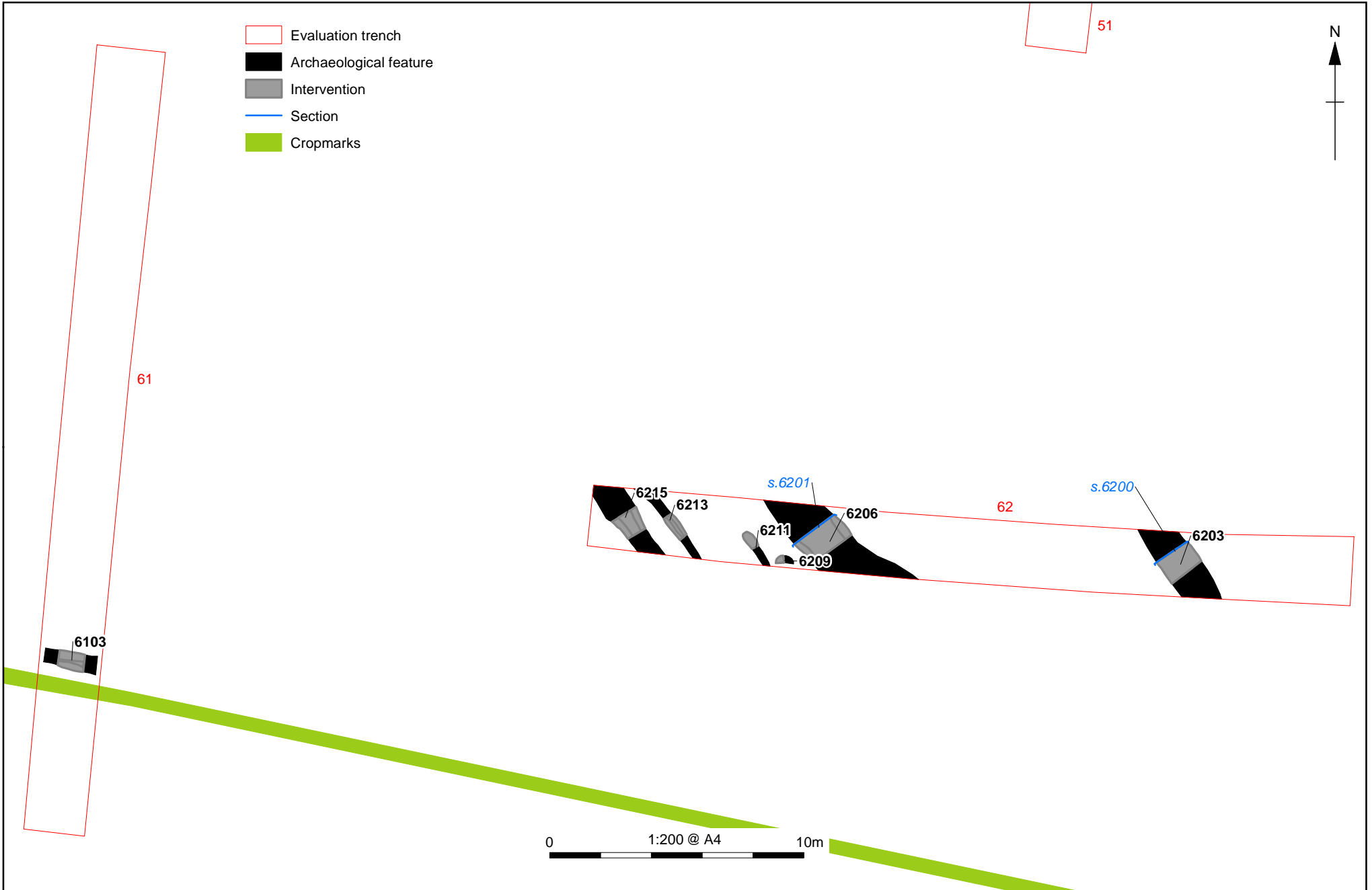

Figure 8: Plan of Trenches 61 and 62



X:\W\TCEV\_Lower\_Thames\_Crossing\010Geomatics\03 GIS Projects - L\TC4OH19\Figures\TC4OH\Fig9.mxd\*aidan.faman\*20/02/2020

- Evaluation trench
- Archaeological feature
- Intervention
- Cropmarks

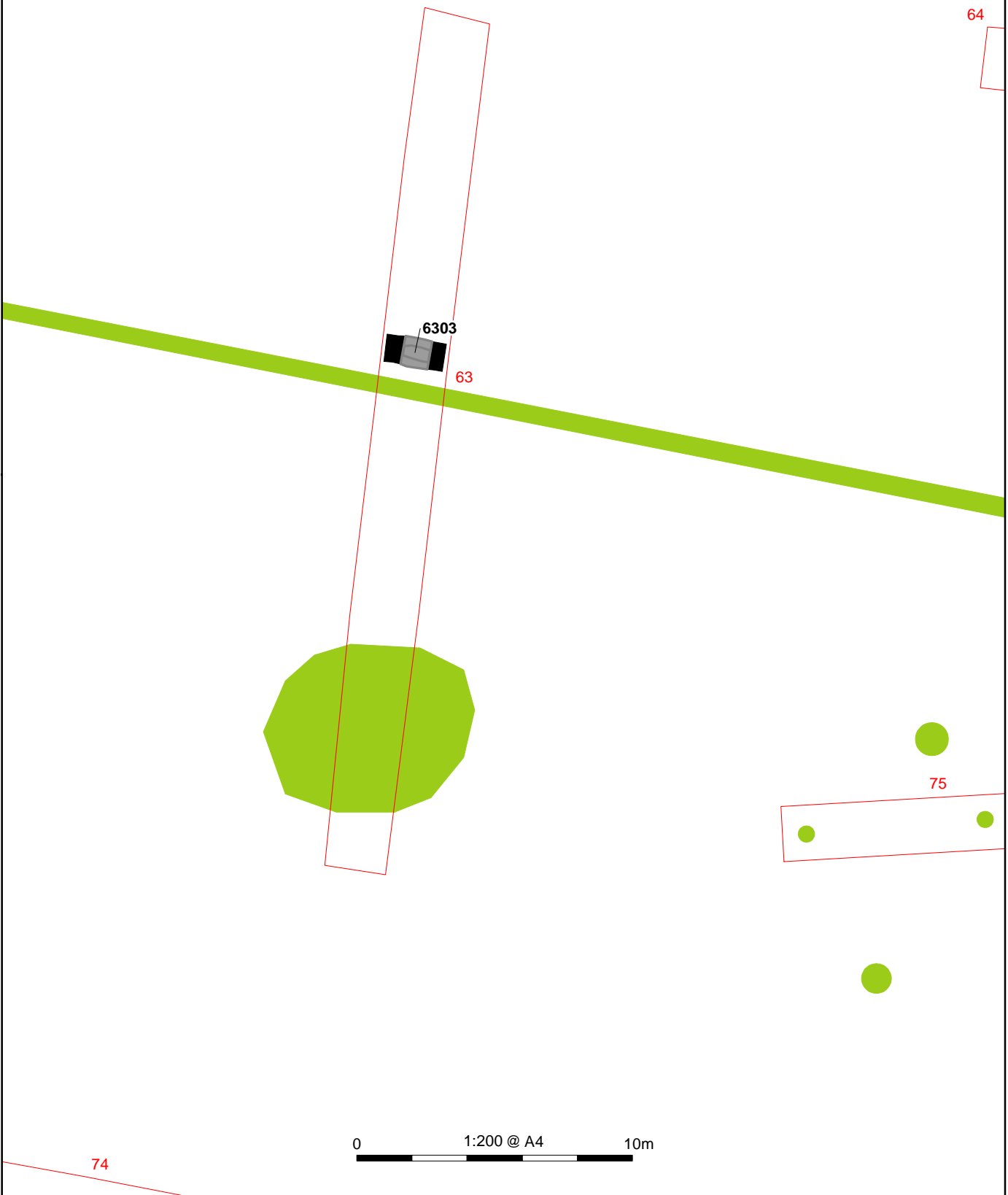
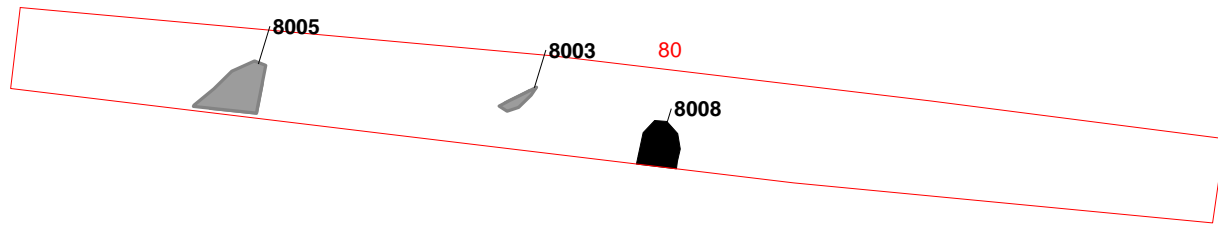
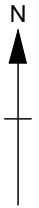

Figure 9: Plan of Trench 63

- Site limit
- Evaluation trench
- Archaeological feature
- Intervention



0 1:200 @ A4 10m

89

Figure 10: Plan of Trench 80

X:\W\TCEV\_Lower\_Thames\_Crossing\010Geomatics\03 GIS Projects - L\TC4OH\19\Figures\TC4OH\Fig11.mxd\* aidan.farman 20/02/2020

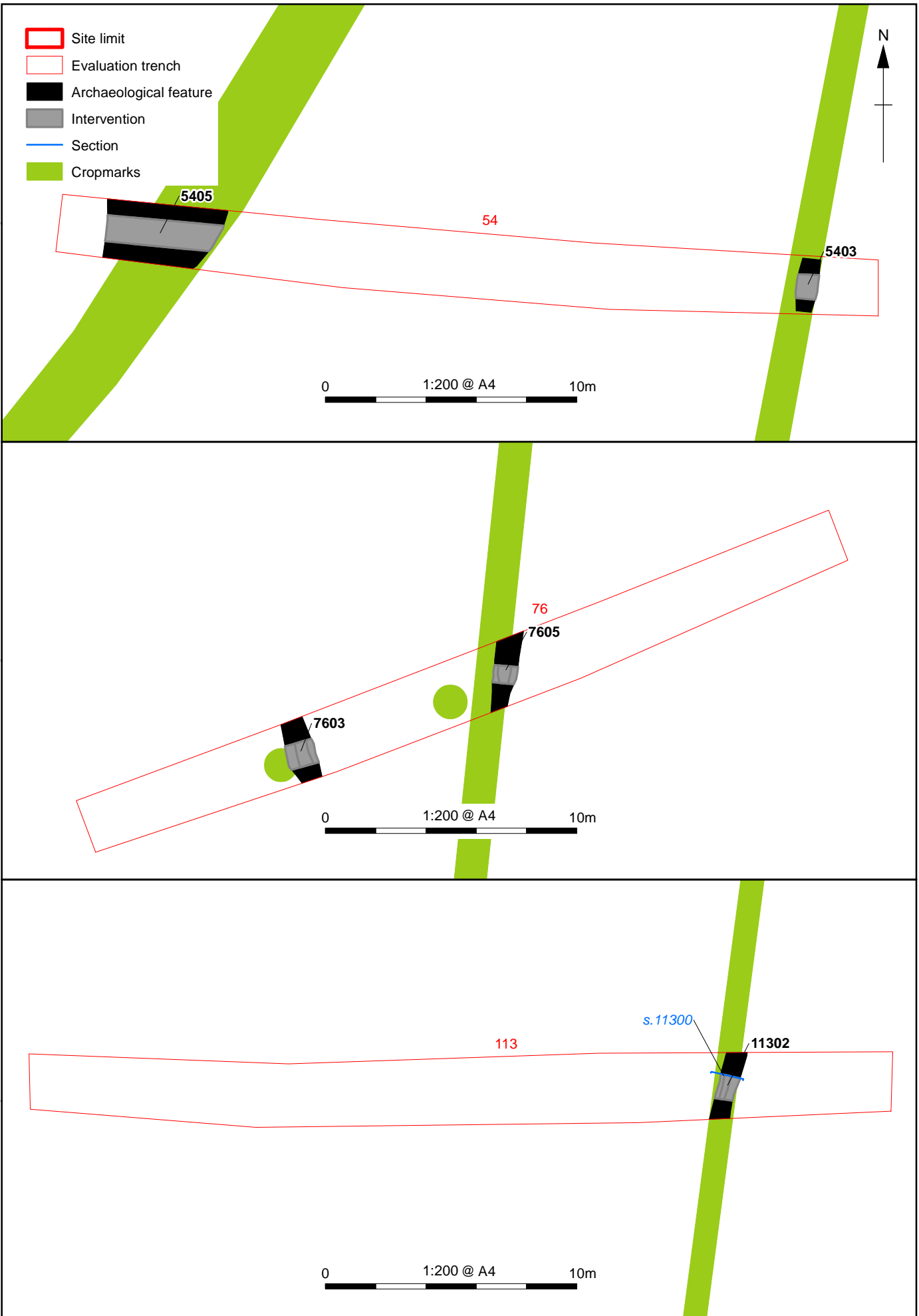

Figure 11: Plan of Trenches 54, 76 and 113

- Evaluation trench
- Archaeological feature
- Intervention
- Section
- Cropmarks
- Deposit

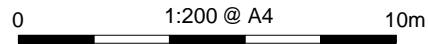
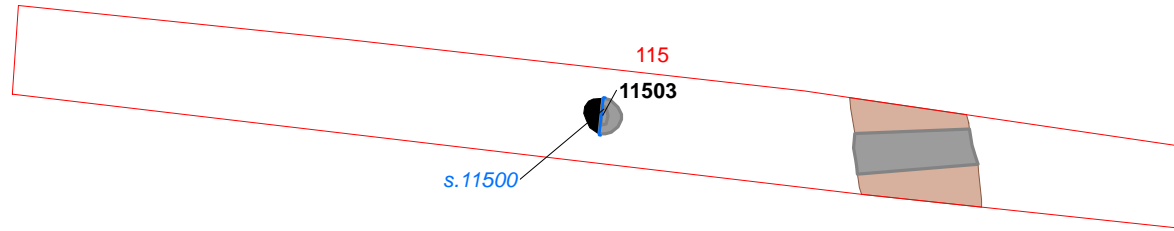

Figure 12: Plan of Trench 115

X:\MLTCEV\_Lower\_Thames\_Crossing\010Geomatics\03 GIS Projects - LTC4OH19\Figures\LTC4OHFig13.mxd\aidan.faman\*27/03/2020

- Site limit
- Evaluation trench
- Archaeological feature
- Intervention
- Deposit

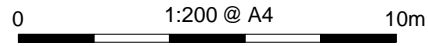
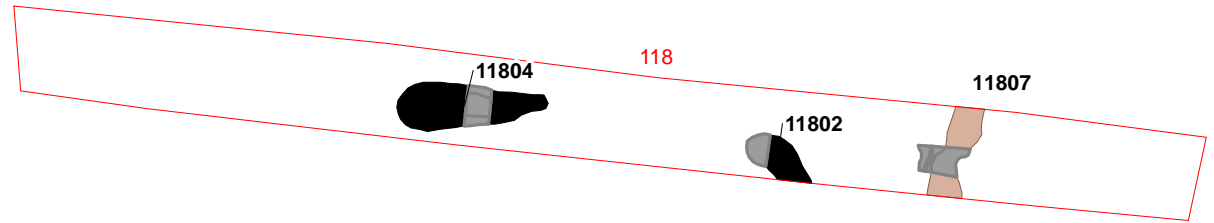

Figure 13: Plan of Trench 118

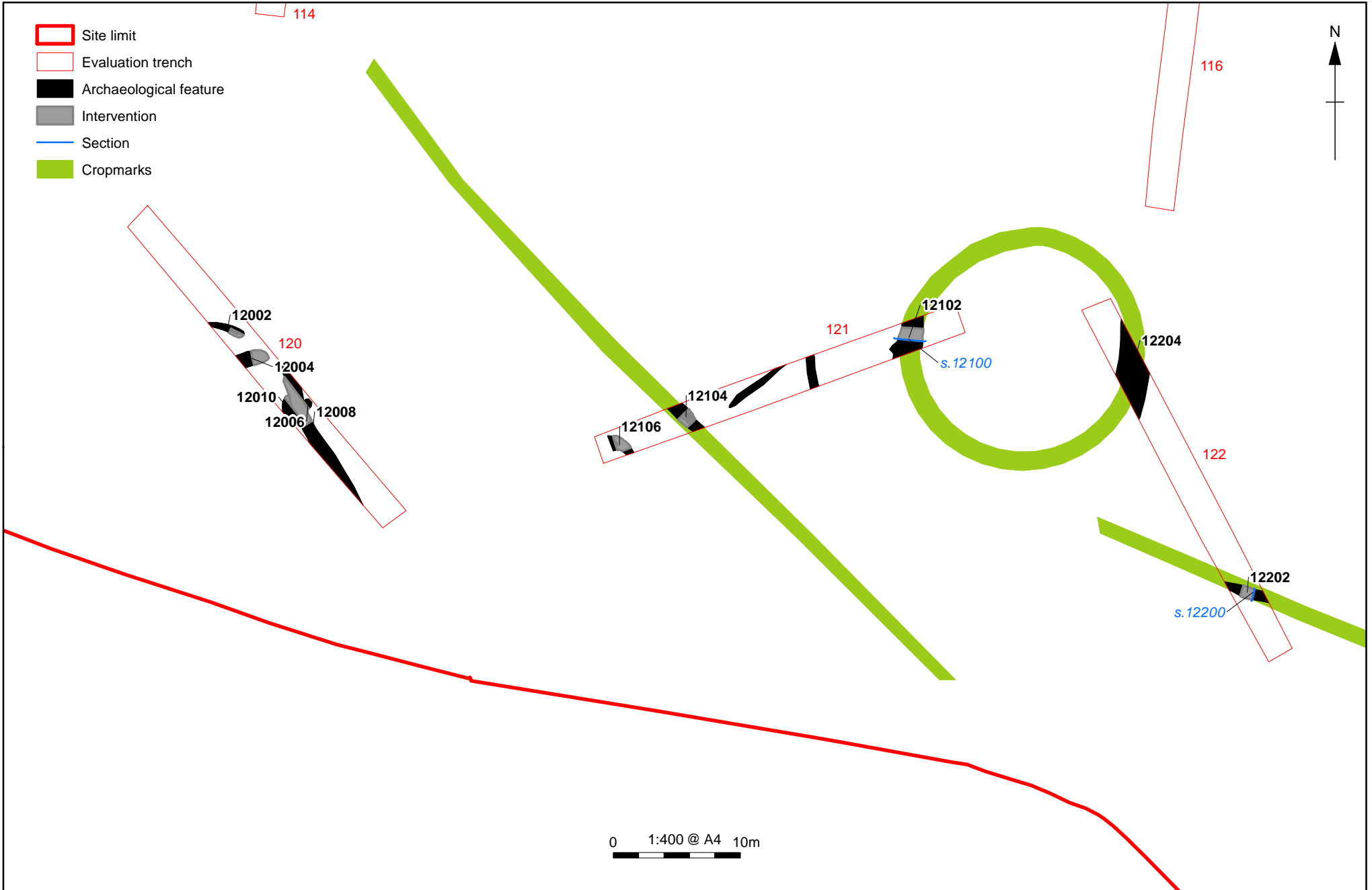

Figure 14: Plan of Trenches 120, 121 and 122

X:\W\TCEV\_Lower\_Thames\_Crossing\010\Geomatics\03 GIS Projects - L\TC4OH19\Figures\TC4OH\Fig 15.mxd\aidan.farman\20/02/2020

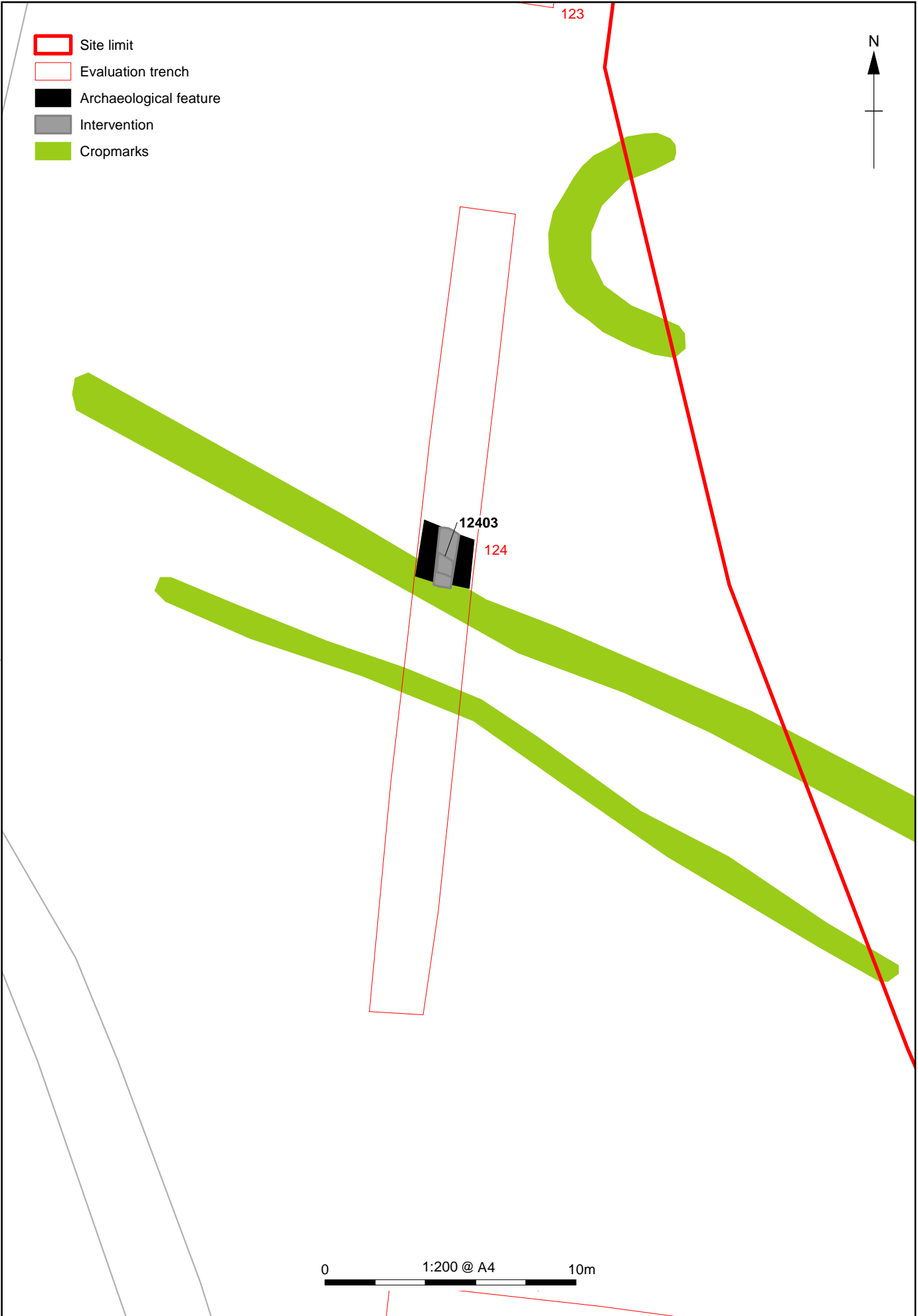

Figure 15: Plan of Trench 124

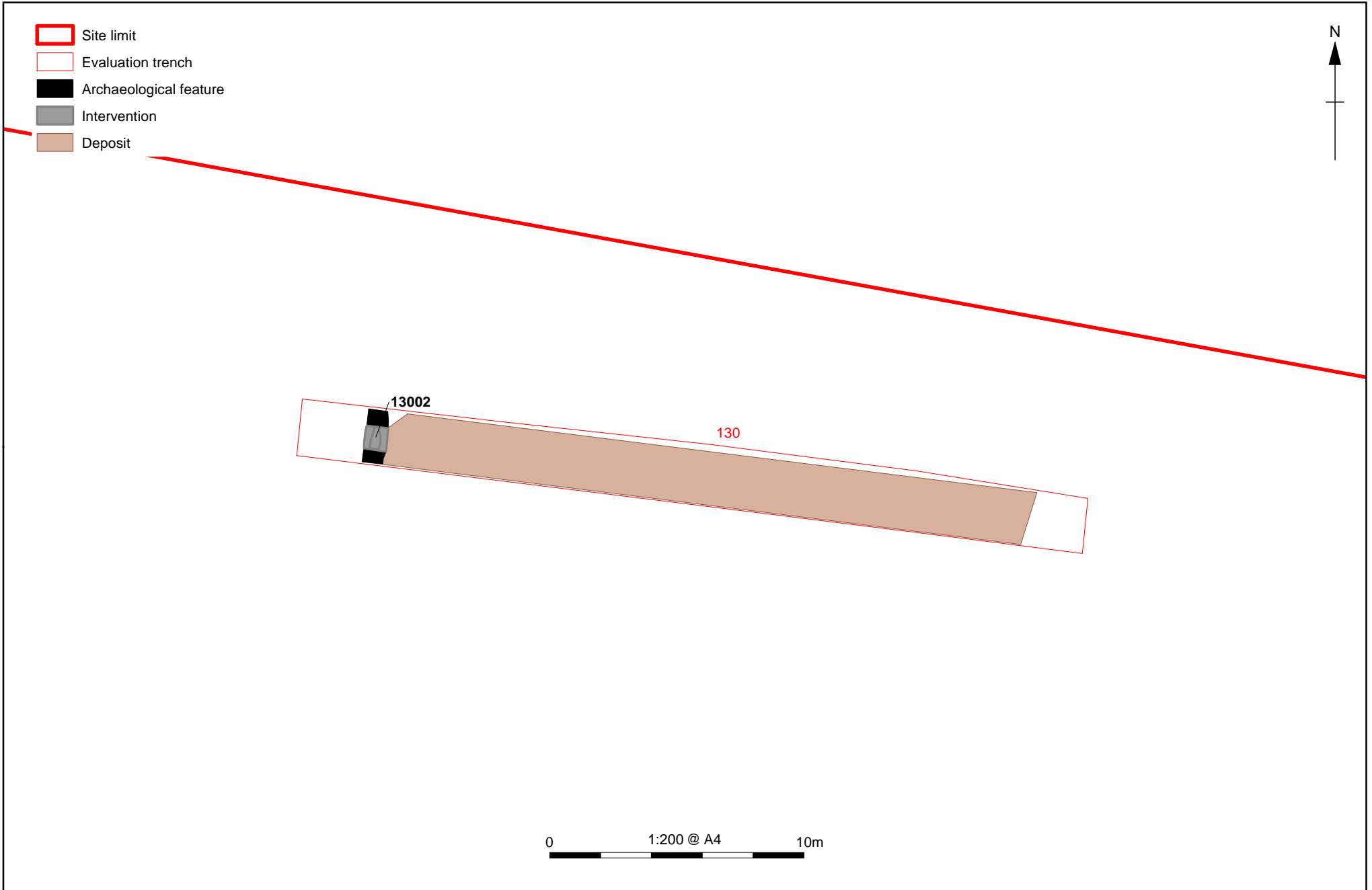

Figure 16: Plan of Trench 130



X:\W\TCEV\_Lower\_Thames\_Crossing\010Geomatics\03 GIS Projects - L\TC4OH\19\Figures\TC4OH\Fig17.mxd\* aidan.farman 2/02/2020

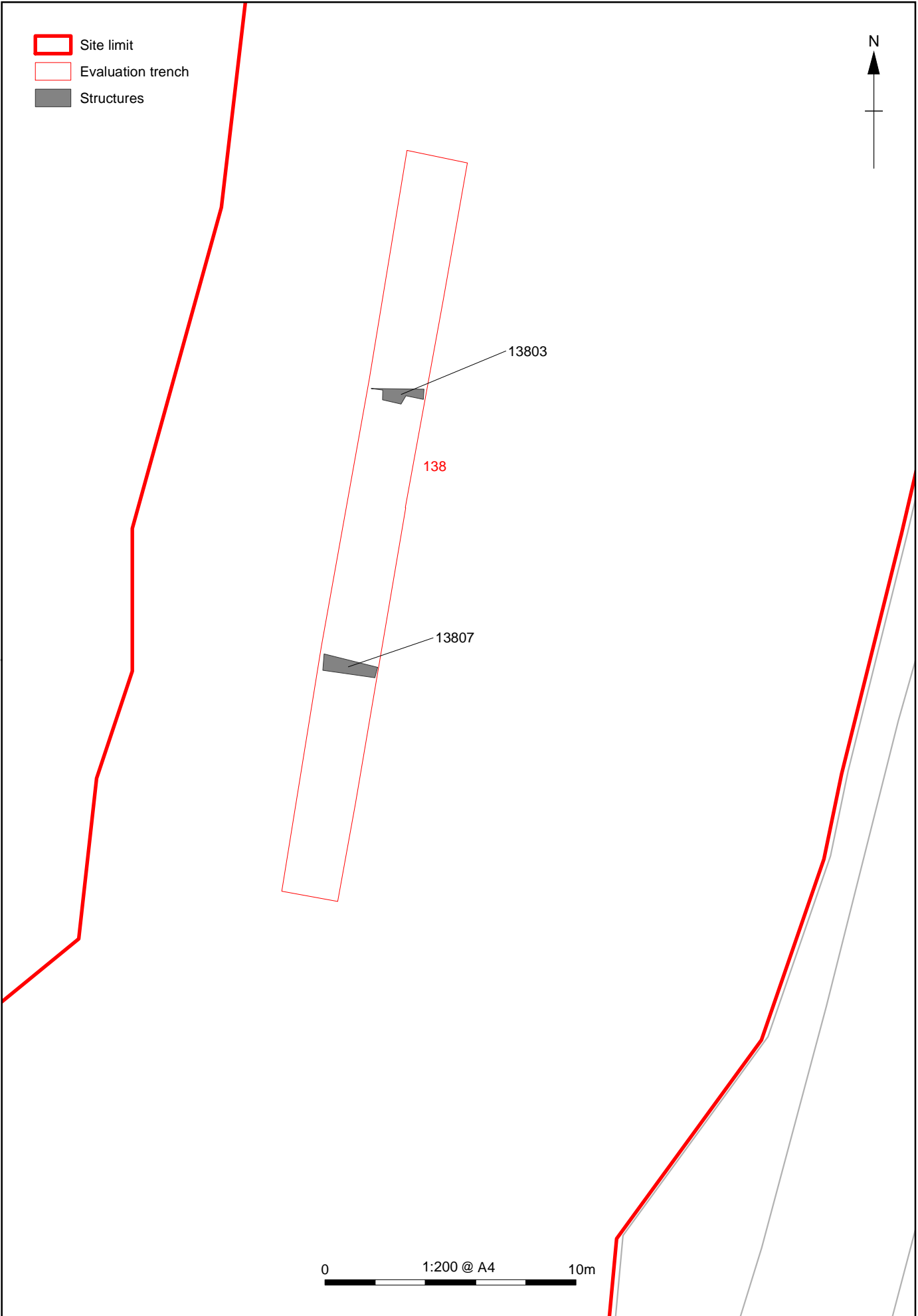

Figure 17: Plan of Trench 138

X:\W\TCEV\_Lower\_Thames\_Crossing\010Geomatics\03 GIS Projects - L\TC4OH\19\Figures\TC4OH\Fig 18.mxd\* aidan.farman 21/02/2020

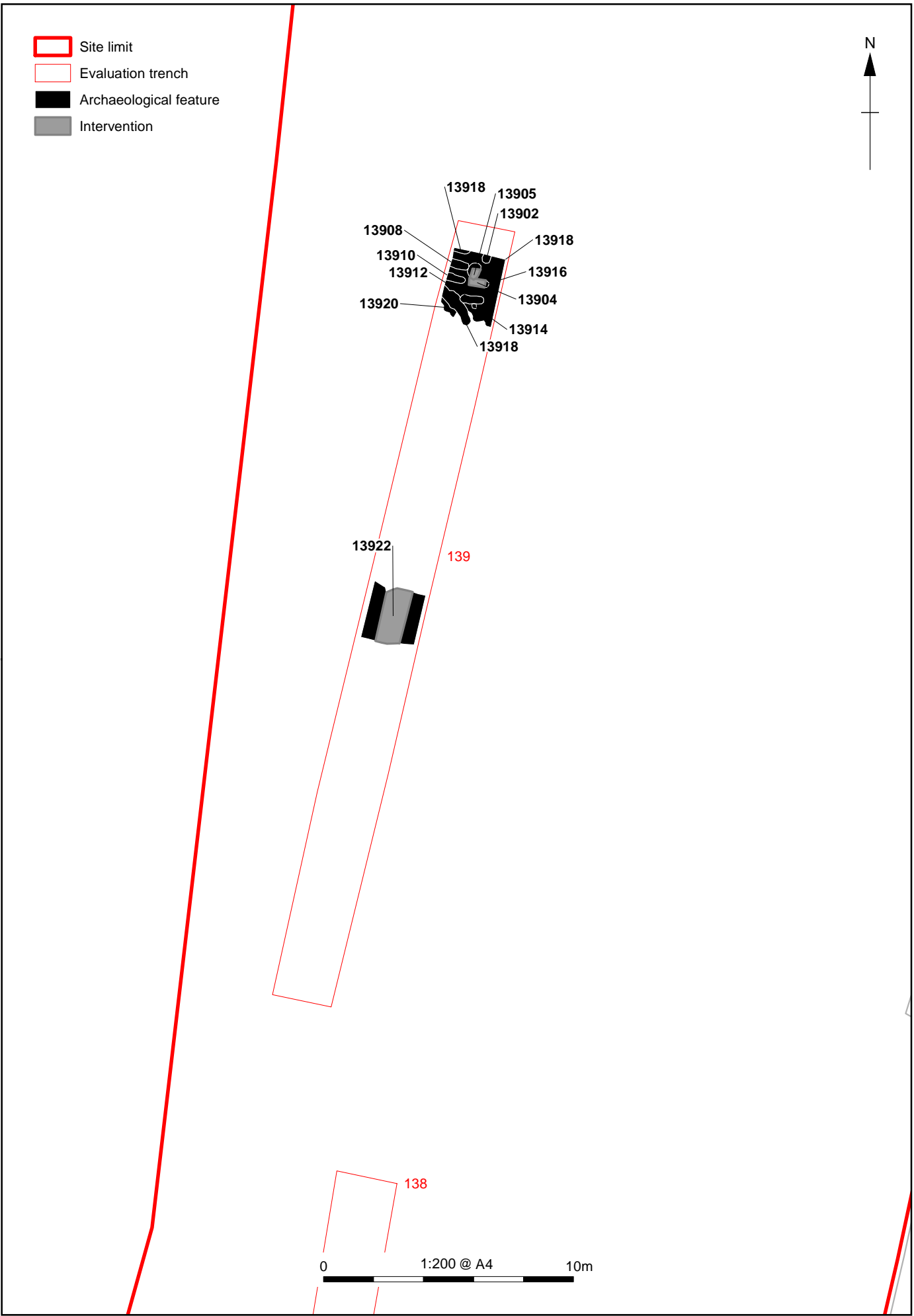

Figure 18: Plan of Trench 139

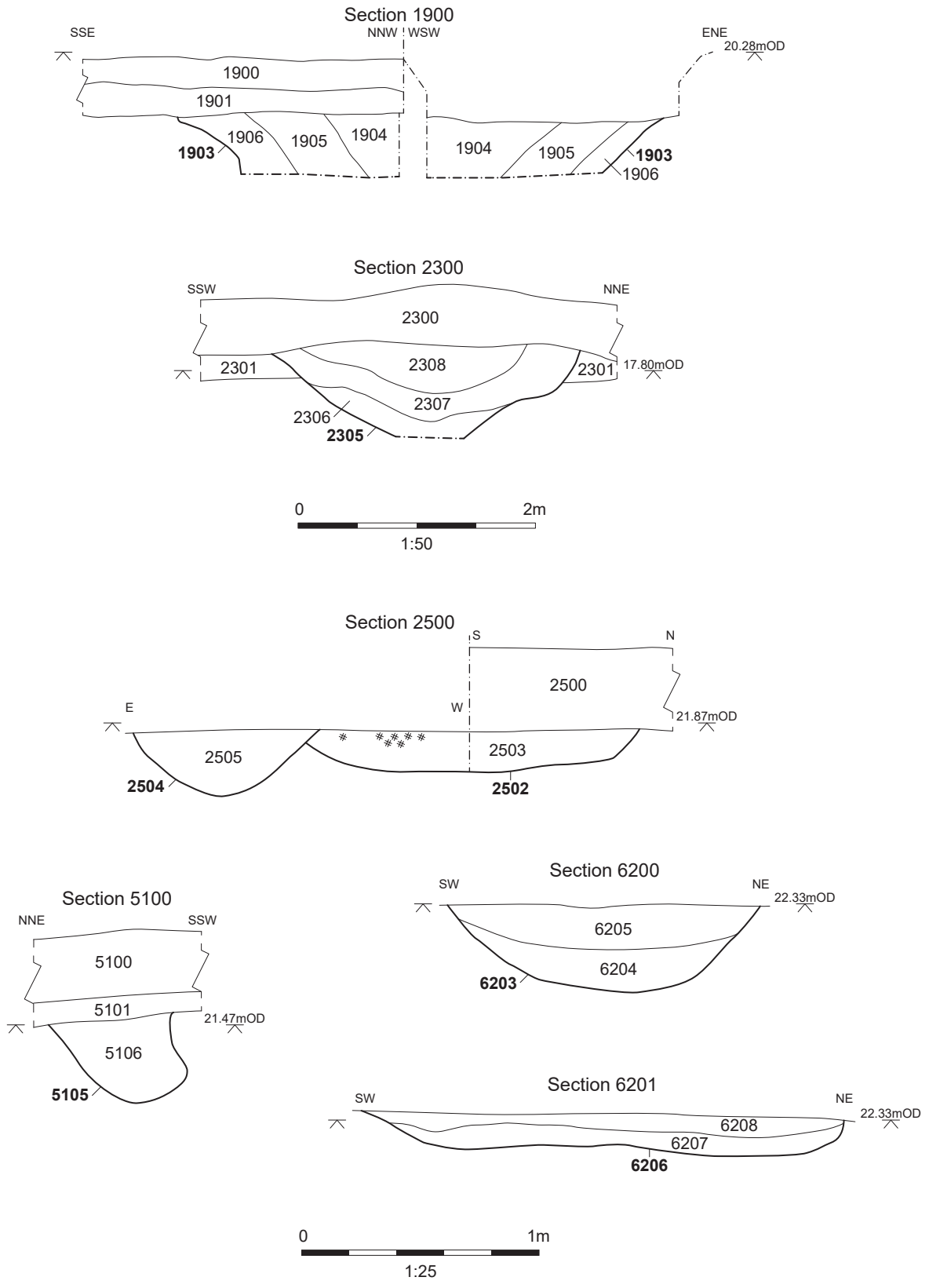

Figure 19: Sections (Trenches 19, 23, 25, 51 and 62)

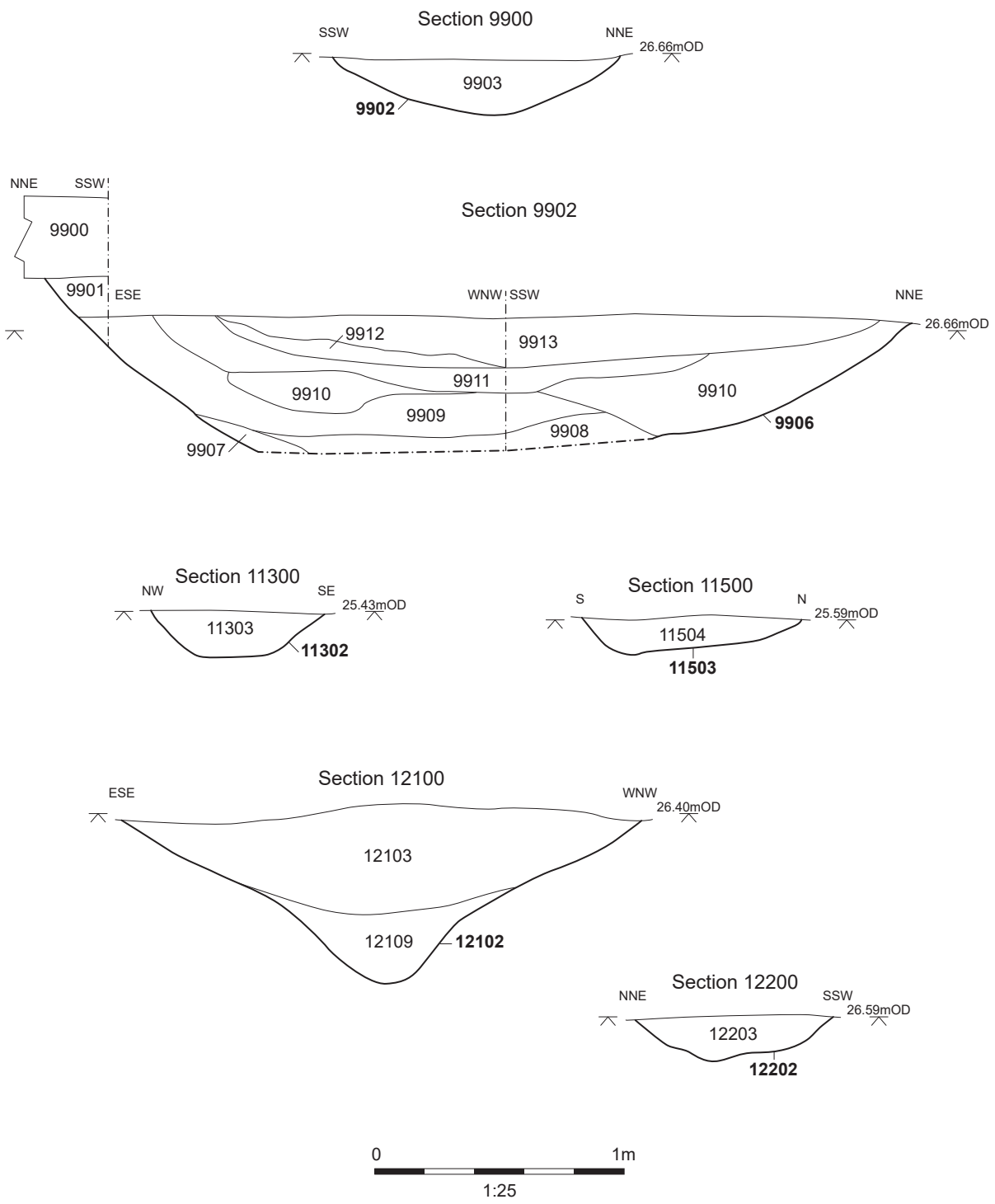

Figure 20: Sections (Trenches 99, 113, 115, 121 and 122)



Plate 1: Ditch 2305 facing north-west



Plate 2: In-situ heat affected soil in pit 3606 facing south-west



Plate 3: Plan view of flint scatter in pit 5103 facing south



Plate 4: Pit 5105 facing east



Plate 5: Pit 9906 facing south-west



Plate 6: Pit 11503 facing west



Plate 7: Ditch 12202 facing east



**COVER SHEET**

<b>Title:</b>	<b>Archaeological Evaluation Report for Trial Trenching of Land Parcel 5 Brook Farm, Essex</b>
<b>Project Name:</b>	<b>Lower Thames Crossing Enabling Works</b>
<b>Ref No:</b>	<b>HE540039-BAL-GEN-GEN-REP-HER-00024</b>
<b>Revision No:</b>	<b>PO1</b>
<b>Review Date:</b>	<b>2<sup>nd</sup> April 2020</b>
<b>Status:</b>	<b>S3</b>
<b>No. of Pages</b>	<b>187</b>

<b>Rev</b>	<b>Date of Issue</b>	<b>Revision Status</b>	<b>Originator</b>	<b>Checker</b>	<b>Approver</b>
PO1	02.04.2020	S3 For Review and Comment	Jack Kilburn	Peter Chartier	George Pargeter



# Lower Thames Crossing

Archaeological Evaluation Report for Trial Trenching of  
Land Parcel 5  
Brook Farm, Essex

Document Number: HE540039-BAL-GEN-GEN-REP-HER-00024

**March 2020**



Revision	Production Date	Prepared by	Checked by	Approved for release by	Sections revised
1.1	16th March 2020	Daniel Stansbie Oxford Archaeology	Edward Biddulph Oxford Archaeology	DRAFT	

This Evaluation Report has been prepared for Highways England in accordance with the terms and conditions of appointment stated in the Lower Thames Crossing (LTC) Technical Partner Contract. LTC cannot accept any responsibility for any use of or reliance on the contents of this document by any third party.

# Contents

Section	Page
<b>Summary</b> .....	<b>6</b>
<b>Acknowledgements</b> .....	<b>7</b>
<b>1 Introduction</b> .....	<b>8</b>
1.1 Project details and scope of work .....	8
1.2 Location, topography and geology .....	9
1.3 Previous investigations .....	9
1.4 Archaeological and historical background.....	10
<b>2 Project Aims</b> .....	<b>14</b>
2.1 General aims .....	14
2.2 Specific objectives .....	15
<b>3 Methodology</b> .....	<b>17</b>
3.1 Constraints.....	17
3.2 Methodology for the evaluation .....	17
<b>4 Results</b> .....	<b>19</b>
4.1 Introduction and presentation of results .....	19
4.2 General soils and ground conditions.....	19
4.3 General distribution of archaeological deposits .....	19
4.4 Trench 17 (Fig. 9) .....	20
4.5 Trench 21 (Fig. 2) .....	20
4.6 Trench 24 (Fig. 2) .....	20
4.7 Trench 26 (Fig. 9) .....	20
4.8 Trench 41 (Fig. 2) .....	20
4.9 Trench 47 (Fig. 4) .....	21
4.10 Trenches 61, 64, 68 and 69 (Fig. 2).....	21
4.11 Trench 94 (Fig. 3) .....	21
4.12 Trench 107(Fig. 3) .....	22
4.13 Trench 111 (Fig. 7) .....	22
4.14 Trench 119 (Fig. 6) .....	23
4.15 Trenches 122, 123 and 131 (Fig. 2).....	23
4.16 Trenches 134,135, 136 and 139 (Fig. 5).....	23
4.17 Trench 147 (Fig. 2) .....	24
4.18 Trenches 152, 153, 155 (Fig. 8) and 164 (Fig. 2) .....	24
4.19 Trench 161 (Fig. 2) .....	26
4.20 Undated features (Fig. 2) .....	26
4.21 Finds summary .....	27
4.22 Environmental summary .....	28
<b>5 Discussion</b> .....	<b>29</b>
5.1 Reliability of field investigation .....	29
5.2 Interpretation.....	30
5.3 Evaluation objectives and results.....	31
<b>Appendix A Trench Tables</b> .....	<b>33</b>

<b>Appendix B</b>	<b>Finds Reports .....</b>	<b>140</b>
<b>Appendix C</b>	<b>Environmental Reports .....</b>	<b>155</b>
<b>Appendix D</b>	<b>References .....</b>	<b>166</b>
<b>Appendix E</b>	<b>Abbreviations and Glossary .....</b>	<b>169</b>
<b>Appendix F</b>	<b>Site Summary.....</b>	<b>170</b>

## Figures

Figure 1 – Site location

Figure 2 - Plan of trench layouts, cropmark features and archaeological features showing 1st Edition OS Mapping

Figure 3 – Plan of Trenches 94 and 107, with late Bronze Age/Iron Age cremation 9402 and Neolithic/Bronze Age pit/tree-throw groups

Figure 4 – Plan of Trench 47 and Beaker pit 4703

Figure 5 – Plan of cropmark enclosure and middle Bronze Age features in Trenches 134, 135, 136 and 139

Figure 6 – Plan of Trench 119 and MBA-LBA ditches 11902 and 11906

Figure 7 – Plan of Trench 111 with LBA/IA Pit 11105 and ditch 11103

Figure 8 – Plan of Trenches 151 to 156

Figure 9 – Plan of Trenches 17 and 26 with late Bronze Age/Iron Age ditch 1709 and medieval pits 2604, and 2606

Figure 10 – Sections (Trenches 17, 24, 26, 47, 94, 107, 111, 119, 123 and 134)

Figure 11 – Sections (Trenches 136, 139, 153 and 155)

## Plates

Plate 1 – Pit 4703, W facing

Plate 2 – Ditch 13903, W facing

Plate 3 – Ditch 13914 with middle Bronze Age pottery, SW facing

Plate 4 – Trench 155, S facing

Plate 5 – Ditches 11902 and 11906, N facing

Plate 6 – Pits 2604 and 2606, NE facing

## Summary

---

Oxford Cotswold Archaeology was commissioned by Balfour Beatty to undertake a trial trench evaluation of Land Parcel 5 of the Lower Thames Crossing Pre-Enabling Works. Land Parcel 5, also known as Brook Farm, is located directly north east of the town of Chadwell St Mary within the county of Essex and Thurrock unitary authority (NGR TQ 65603 79864). The evaluation comprised 168 trenches and was completed between 6th January and 14th February 2020.

The earliest recorded activity comprised two parallel groups of pits/tree-throws dating to the Neolithic or early Bronze Age, located close to the southern edge of the site. In addition, a single pit from a trench in the south-central part of the site contained Beaker pottery and abundant charcoal. A cropmark suggesting the presence of a ring-ditch in the central part of the site was investigated by a single trial trench but did not produce any dating evidence.

Two trenches at the eastern end of the site contained features dated to the middle Bronze Age and late Bronze Age to Iron Age respectively. Two of these features correlated with a cropmark representing a sub-rectangular enclosure, suggesting the presence of an enclosure of middle Bronze Age date.

A scatter of linear features and colluvial deposits in seven trenches along the northern edge of the site produced late Bronze Age-Iron Age pottery, suggesting a focus of activity of this date. In addition, two trenches in the southern central part of the site produced a pit containing late Bronze Age to early Iron Age pottery and middle to late Bronze Age pottery respectively. These features were situated to the south of some undated linear cropmarks that were not aligned on modern field boundaries. Trench 97 in the central-eastern part of the site contained a late Bronze Age to early Iron Age cremation burial. There is therefore some limited evidence for middle and late Bronze Age activity across the central section of the site.

Four trenches in the south-eastern corner of the site contained pits and linear ditches producing occasional sherds of late Bronze Age to Iron Age date, but also two sherds of Roman date. This suggests an activity focus of late Bronze to Iron Age date, with additional Roman activity in the south-east corner of the site.

Very occasional sherds of Roman pottery from topsoil and colluvial layers across the site suggest very limited activity of this date of unspecified character. In addition, a trench at the western end of the site contained two pits from which medieval pottery was recovered, which perhaps suggest sand or gravel digging activity.

Linear and curvilinear cropmarks at the western end of the site and on the southern boundary align with the field boundaries shown on the first edition OS map, suggesting that they represent post-medieval field boundaries themselves. In addition, a small quantity of post-medieval pottery and ceramic building material was distributed across the site in the ploughsoil, perhaps deriving from agricultural activities associated with Brook Farm, which occupied part of the north-western corner of the site (OS 1889).

The site contained many irregular-shaped features, 1-3m in diameter, which were identified as cropmarks and were targeted in numerous trenches. Where investigated, these comprised variations in the gravel or sand and silt content of the geology and were clearly not of archaeological origin.

## Acknowledgements

---

Oxford Cotswold Archaeology would like to thank the client, Balfour Beatty, for commissioning this project and managing the site safety and attendances. Thanks are also extended to the Historic Environment Consultants (Richard Havis and Katie Lee-Smith) of Place Services at Essex County Council, advising the Borough of Thurrock, for monitoring and providing advice throughout the project.

The project was managed for Oxford Cotswold Archaeology by Steve Lawrence. The fieldwork was directed by Mark Dodd and Anna Moosbauer, who were supported by Robert McIntosh, Jana Smirnova, Adam Moffat, Megan Lillington, Dan Firth, Eilidh Barr, Fanny Dubuc and Adrian Arenas. Site survey was undertaken by Caroline Souday and Rachel Alexander and digitising was carried out by Gary Jones, Benjamin Brown and Simon Batsman. Thanks are also extended to the teams of OA staff that cleaned and packaged the finds under the management of Leigh Allen and Geraldine Crann, processed the environmental remains under the management of Rebecca Nicholson, and prepared the archive under the management of Nicola Scott.



# 1 Introduction

---

## 1.1 Project details and scope of work

- 1.1.1 The Lower Thames Crossing Project is located between the A2 in Kent and the M25 in the London Borough of Havering. It will run underneath the River Thames through a tunnel and emerge on the northern side of the river at East Tilbury. From the North Portal the road will run to the M25 at Junction 29 via the A13 and pass between North and South Ockendon. The development of the project is managed by LTC, a partnership between Highways England and a consultancy joint venture set up to oversee the scheme.
- 1.1.2 A programme of archaeological trial trenching commenced in the Essex part of the scheme in November 2019. A scheme-wide specification for trial trenching was written by LTC (Highways England 2018), and in July 2019, LTC commissioned Balfour Beatty to deliver the pre-Enabling Works. Balfour Beatty appointed Oxford Archaeology (OA) to prepare a project-wide written scheme of investigation (WSI) for the scheme, which (at the request of the key archaeological stakeholders) is divided into two parts, one for the Kent section, and another for Essex and Havering (Oxford Archaeology 2019a; 2019b).
- 1.1.3 Following completion of the project-wide WSIs, OA was instructed to prepare a series of site-specific or group-site specific WSIs for approval by the key archaeological stakeholders in advance of trial trenching to inform the Development Consent Order (DCO). A detailed WSI was created for Land Parcel 5 prior to the trial trenching (Oxford Archaeology 2019c), which details the archaeological background and potential within the site. It also sets out the archaeological aims and objectives appropriate to the investigation of this land parcel by trenching and describes the methodology to be applied. The WSI was approved by Richard Havis, Principal Historic Environment Consultant for Place Services at Essex County Council, prior to the start of the fieldwork. Oxford Cotswold Archaeology was commissioned as Balfour Beatty's archaeological contractor to undertake the evaluation in accordance with the approved WSI and local and national planning policies.
- 1.1.4 The fieldwork was completed between 6th January and 14th February 2019. All work also followed the MoRPHE Project Manager's guide (Historic England 2015), and the Code of Conduct of the Chartered Institute for Archaeologists (CIfA). The archaeological works adhered to the standards and guidance for archaeological evaluation, excavation and archiving (CIfA 2014a; CIFA 2014b).
- 1.1.5 The work was monitored by Richard Havis and Katie Lee-Smith of Place Services on behalf of the Borough of Thurrock.

## 1.2 Location, topography and geology

- 1.2.1 Land Parcel 5 is located directly north east of the town of Chadwell St Mary (Fig. 1) within the county of Essex and Thurrock unitary authority (NGR TQ 65603 79864). The land parcel is roughly rectangular with two projecting areas to the south and covers an area of 32.59ha. It is bounded to the west by Brentwood Road, to the north by Orsett Golf Course and a field, to the south by further fields and to the south-west by Chadwell-St-Mary. High House Lane, a single-track road, runs through the north-western part of the land parcel. An industrial works road, constructed to allow works traffic to access an agricultural reservoir, lies within the north-western part of the land parcel. There is a small farm (Brook Farm) within the western part of the land parcel.
- 1.2.2 The bedrock geology of Land Parcel 5 is Thanet Formation (sand). The superficial geology of the land parcel is mixed with much of the western part of the land parcel underlain by Boyn Hill Gravel Member (sand and gravel). In addition, the northern and eastern edge of the land parcel is underlain by Head (clay, silt, sand and gravel). This colluvial layer was formed by fine grained materials collecting at the base of a slope (BGS 2020).
- 1.2.3 The land parcel is currently in use as part of three large arable fields and by Brook Farm. Within a 1km-radius of the site, land use is mainly a mixture of agricultural land and urban development associated with Chadwell St Mary. There is also some industrial activity, with a Tarmac plant located 0.5km east of the land parcel, and leisure use, with Orsett Golf Course located to the north of the study area. The land parcel and study area are also bisected by three roads, Brentwood Road, High House Lane and Hoford Road (Fig. 3). Hoford Road is now partly a green lane.
- 1.2.4 The land parcel is situated across the west end of a dry valley which runs ESE across the gravel terrace to the south of Orsett (Fig. 2). A 'tributary' valley also runs WNW south of Land Parcel 5 and joins the main valley in the eastern part of the parcel. The northern edge of this 'tributary' is clipped by the southern extension along High House Lane. The highest ground within the land parcel is in the south-western corner, where the terrace is at a height of c 24-25m aOD. There is a gradual slope down to the north and north-east, and the northern edge of the land parcel runs roughly along the dry valley, the lowest point within the site being halfway down the eastern side of the parcel at a height of 5-20m aOD.
- 1.2.5 Colluvial deposits of head have accumulated within the lower parts of the dry valley. A drainage ditch is located along the northern edge of the land parcel and this appears to originate at Brook Farm. It may have continued south-eastward, as a small reservoir and a stream are located c 400m east of the land parcel. The stream flows eastwards around Linford and down the river valley towards the Mucking marshes.

## 1.3 Previous investigations

- 1.3.1 No known below-ground archaeological investigation has been undertaken within this land parcel. The only area that has seen modern

development is within the immediate vicinity of Brook Farm within the north-western part of the land parcel.

## 1.4 Archaeological and historical background

- 1.4.1 The chronological summary of known archaeology given below is taken from the detailed WSI for Land Parcel 5 (Oxford Archaeology 2019c). The site is situated on the terrace to the south of the Mar Dyke valley where Holocene prehistoric features, find spots and cropmarks have been identified. The cropmarks that have been recorded within the site are those mapped by the 'Aerial Investigation and Mapping Report' (Place Services 2019). These cropmarks are shown on Figure 2.
- 1.4.2 **Palaeolithic.** A large number of Palaeolithic finds have been recorded c 100m south of the land parcel. This includes 115 handaxes, two roughouts and six flakes, found within an area of Boyn Hill Gravel. Palaeolithic finds have also been recorded c 900m north-west of the land parcel 5.
- 1.4.3 **Mesolithic.** Several Mesolithic finds have been identified 0.6-0.8km west of the land parcel, including two flint blades. Mesolithic find spots have also been recorded 1km to the west.
- 1.4.4 **Neolithic.** An early Neolithic causewayed enclosure (Place Services 2019, site 17A), a scheduled monument, is located 0.4km north-west of the land parcel. Pottery found within the causewayed enclosure was of Mildenhall type, dating to the early Neolithic. Flints of the same date were also recovered. The secondary ditch silts of the enclosure contained a small quantity of late Neolithic/early Bronze Age pottery (Hedges and Buckley 1978, 219-308).
- 1.4.5 Several Neolithic flints, including blades, scrapers, arrowheads, cores and hammer stones, were recorded along the southern boundary of the scheme and 0.5-0.6km west of the site. The largest number of these flints were collected at grid point NGR 564700 180000.
- 1.4.6 A Mesolithic or Neolithic flint macehead/axe was recorded 0.3km east of the site and 3m above the valley bottom. A Neolithic axehead was also recorded nearby, 0.2km east of the site.
- 1.4.7 **Bronze Age.** In 2010 a photographic survey and evaluation was undertaken at Mill House Farm, located 500m south of the land parcel. A number of cropmarks were recorded in this area prior to the evaluation and these were targeted by the trial trenching. The evaluation recorded a number of enclosure ditches, pits, postholes, gullies and ring ditches. Pottery (94 sherds) was found within several ditches, a pit and a ring-ditch dating to the late Bronze Age/early Iron Age. This site was interpreted as a late Bronze Age/early Iron Age enclosed settlement with an associated funerary monument (Schofield 2010). Cropmarks have also been recorded east of this site and 600m south-east of Land Parcel 5, including linear features and an extensive number of pits (Place Services 2019, site 71). An extensive area of cropmarks was identified further south-east of Mill House Farm by the aerial survey just north of the Muckingford Road and 800m south-east of the site (ibid., site 24B). This site includes linear features, ring-ditches, pennanular ditches and pits (ibid., site 26).

- 1.4.8 Cropmarks of number possible ring-ditches have been identified both within the centre of the land parcel and close to it. The ring-ditch, or possible hut circle within Land Parcel 5 is located in the centre and is 8.6m in diameter. A number of linear features and two bands of pits are located within the land parcel (ibid., site 24A), while three ring-ditches and several pits have been recorded west and south-west of the land parcel (ibid., site 18). It is possible that these cropmarks are indicative of Bronze Age/Iron Age activity, as revealed by the Mill House Farm evaluation, c 500m south of Land Parcel 5.
- 1.4.9 The Essex Historic Environment Record (HER) lists four bronze torcs and a bronze pin, which were found in parish of Orsett and these objects were presented to the Victoria and Albert Museum in 1901. The exact site where these objects were found is unknown, but it does suggest the possibility of high-status Bronze Age finds.
- 1.4.10 **Iron Age.** The Neolithic causewayed enclosure was overlain by an unenclosed early Iron Age site and a middle Iron Age sub-rectangular enclosure (Hedges and Buckley 1978, 219-308). Cropmarks, including pits, linears and ring-ditches, extend from the area of the scheduled early Iron Age enclosure (Place Services 2019, sites 17A, 17B and 72). Additional cropmarks, recorded by the HER, extend further east and 0.5km north of Land Parcel 5, and include ring-ditches, trackways and linear features. Some of these were mapped by the aerial survey (Place Services 2019, site 19A).
- 1.4.11 A large number of intercutting cropmarks are present c 900m west of Land Parcel 5 and it is likely that multiple periods are represented, possibly dating from the Neolithic, Iron Age and Roman period (Place Services 2019, site 20). A large quantity of high-status Iron Age material was recovered by metal detectorists within that area.
- 1.4.12 A cello-shaped enclosure is located 0.7km west of Land Parcel 5. This contains several circular cropmarks, possibly representing penannular ditches (Fig. 5; Place Services 2019, sites 22 and 32). It is possible that this cello-shaped enclosure is of Iron Age date. Further east, 200m west of Land Parcel 5, another enclosure was identified by an aerial photograph taken in 1946. The rectangular enclosure with a sub-rectangular annexe, now no longer extant, having been destroyed by a residential development, may be Iron Age to Roman in date (Place Services 2019, site 56).
- 1.4.13 A small Iron Age settlement was identified by excavation in 1955 within a gravel quarry, c 0.8km north-east of Land Parcel 5. Features included pits, hearths and a possible hut. Several pottery kilns were also recorded. The kilns were clay-lined and contained charcoal and sherds of pottery. The pottery within these features dated to the early Iron Age (Barton 1962, 57-104).
- 1.4.14 **Roman period.** The route of a possible Roman road is projected to run through the western part of the site on an NNE-SSW alignment. Two other Roman roads are thought to pass within 1km of the site, one to the south that is aligned east-west, the other to the east that is aligned NW-SE. It is

possible that additional Roman roads or trackways cut roughly east-west across the terrace.

- 1.4.15 Two Roman findspots have been identified close to the route of the possible Roman road and c 0.4km north of the land parcel: a bronze fibula dated c 100 BC-AD 60, which was a residual find in a Saxon ditch, and Roman pottery (possibly 1st century) that was found to the north of the site of Seaborough Hall.
- 1.4.16 The site located 0.8km north-east of Land Parcel 5 may have also been used during the Roman period. During the 1955 excavation of the site, workers are reported to have found six bottle-neck-shaped structures, cut into the gravel and lined with clay and full of pottery. It is probable that these structures, now destroyed, were Roman pottery kilns. The excavation also uncovered Roman pottery dating to the 2nd-4th century scattered over a wide area, suggesting a possible agricultural use for this area in the Roman period (Barton 1962, 57-104).
- 1.4.17 An extensive, rectilinear enclosure was identified c 800m west of Land Parcel 5 (Place Services 2019, site 20). This NW-SE aligned rectilinear enclosure (250m long by 200m wide) has an associated trackway to the south and internal subdivisions. The size and regularity of this enclosure suggest that it could be Roman in date. A number of other linear ditches surrounding the enclosure run parallel and perpendicular to it and these may be associated field systems and additional enclosures.
- 1.4.18 Several copper coins of Carausius were found in this general area in 1906 but the exact location is unknown. Carausius reigned over Britain and Gaul from AD 286-293 and so although the exact location is unknown it does indicate later 3rd century Roman activity in this vicinity.
- 1.4.19 **Medieval period.** Middle Saxon activity has been identified north-east and north-west of the land parcel. The Orsett causewayed enclosure was reused as a Saxon funerary monument in the 7th-8th century. A Saxon settlement was also located 1km north of the land parcel at Orsett Cock.
- 1.4.20 The 1955 excavation c 0.8km north-east of Land Parcel 5 revealed an extensive Saxon settlement with sunken floored buildings and rectangular buildings. A possible weaving hut was found with twenty loom-weights. Some of the Saxon pottery had Continental parallels and dated to the end of the 4th or 5th century (Barton 1962, 57-104).
- 1.4.21 In the later medieval period, Land Parcel 5 was located at the intersection of four parishes: Orsett, Mucking, Chadwell and West Tilbury. The medieval settlement of Chadwell is likely to have been located c 1.3km south of the site in the vicinity of the early 12th century church of St Mary. The nucleated parts of the medieval settlements of Orsett, Mucking and West Tilbury are likely to have been located c 0.9km north, c 1.5km east and c 1.6km to the south of the site respectively. There may have also been a dispersed settlement pattern in the later medieval period with medieval farmsteads situated along Brentwood Road and Holford Road. In the later medieval period it is likely that the site was used for agricultural purposes associated with the parishes of Chadwell and West Tilbury.

- 1.4.22 **Post-medieval period.** Documentary evidence indicates that the land parcel was situated between Brentwood Road and Holford Road and that High House Lane was just a track in the late 19th century.
- 1.4.23 The post-medieval Brook Farm was partly located in the northern part of the site. In the later 19th century it appears that this farm was more extensive than it is now, as there were several north-south aligned buildings within the land parcel to the south of the main house and several outbuildings. The western part of the site was almost certainly used as agricultural land in the 19th century and associated with Brook Farm. There are several cropmarks that were identified within the site that are almost certainly post-medieval field boundaries, including one that zigzags at two 90-degree angles in the western part of the site and a NE-SW aligned linear feature to the south-east (Fig.2). These features are shown on the 1839 tithe map of Chadwell St Mary (D/CT 70). The NE-SW-aligned linear feature was a former hedgerow, which marked the boundary between the parishes of Chadwell to the north and West Tilbury to the south. This hedgerow has now been removed and this area forms part of a large field.
- 1.4.24 The site of the medieval to post-medieval manor of Seaborough Hall was located c 200m north-west of the site and west of Brentwood Road. This building is first mentioned in the 13th century and it appears on the OS map of 1897. The manor house was demolished in the 20th century and all that remains is a wall adjacent to Brentwood Road (Thurrock Local History Society 2019).
- 1.4.25 The 18th-century Grade II listed High House is located 800m south of the site to the west of High House Lane. It is likely that the existing High House Lane takes its name from the house.
- 1.4.26 **Undated features and cropmarks.** The cropmarks of a double-ditched rectangular enclosure are located 0.2km east of the land parcel. The enclosure appears to have an entrance on the southern and western side. Another rectangular feature is also located nearby and a possible trackway is located to the north-west (Place Services 2019, site 25).
- 1.4.27 The cropmarks of a possible trackway including two widely spaced parallel ditches aligned NE-SW are located 100m north of the site. This appears to be truncated by a rectangular enclosure (Ibid., site 79).
- 1.4.28 The linear and discrete features located within Land Parcel 5 are undated, although some aspects have been tentatively discussed by period above. The features include a possible sub-rectangular enclosure towards the east of the land parcel, linear features and sections of enclosure in the centre and linear features towards the west. There are also a number of pits and amorphous features that have been mapped by the aerial survey (Fig. 2). The majority of these features are probably natural in origin, and some may relate to colluvial processes as the site is located on a slope.

## 2 Project Aims

---

### 2.1 General aims

2.1.1 The general aims of the project were as follows:

- To establish the presence or absence of archaeological remains along the line of the scheme, and the extent of any areas where remains appear likely to be absent.
- In areas where archaeological remains are known or suspected, to clarify the reliability of the cropmark or geophysical survey evidence.
- In areas where no archaeological remains are indicated by aerial or geophysical survey, to clarify whether this apparent absence of remains is genuine.
- To determine the degree of complexity of any surviving horizontal or vertical stratigraphy, and in particular, to investigate areas where topography indicates the likelihood of deep deposit sequences for evidence of buried archaeological horizons and palaeo-environmental sequences.
- Where remains are present, to determine the period(s) represented, the extent, state of preservation and character of the archaeological remains.
- To establish the range and state of preservation of archaeological artefacts, and through their recovery and examination, to establish the potential for information about the economy, status and contacts of past inhabitants of the scheme footprint.
- To determine whether palaeo-environmental remains are preserved, and, where these are found, to determine their types (e.g. charred plant remains, waterlogged remains, molluscan remains), state of preservation and potential for environmental information. This will be achieved through the recovery of samples from sedimentary sequences and archaeological features suitable for assessment of a range of palaeoenvironmental remains (e.g. charred and waterlogged plant remains, charcoal, insects, pollen, diatoms, ostracods/foraminifera and molluscs) and scientific dating (e.g. radiocarbon and OSL dating).
- To investigate and record the extent, character and chronology of the sedimentary sequences, in particular those immediately adjacent to and in floodplains, contained within palaeochannels or in dry valleys, and to use the data to refine existing geoarchaeological (predictive) deposit models.
- To place any identified archaeological remains into their local and, where appropriate, regional or national context, and to assess the implications of any such discoveries for our current understanding of settlement and landscape change in the area, including an assessment of the associations of any remains with reference to the historic landscape.

- To provide sufficient information to enable the LTC archaeological advisor, in consultation with the Key Archaeological Stakeholders, to determine the significance of the archaeological assets identified within the land parcel.
- To provide a report on the discoveries to inform the Environmental Statement (ES) supporting the Development Consent Order (DCO) and support the preparation of a further archaeological mitigation strategy for the Enabling Works and Construction phases of the scheme.
- Following the DCO, to deposit the report in the public domain, and to generate an accessible and useable archive which will allow future research to be undertaken.

## 2.2 Specific objectives

2.2.1 The specific project objectives were as follows:

- To conduct the programme of archaeological investigation within the general research parameters and objectives defined by the revised East of England Research Framework (Medlycott 2011), and to take account of the aims and objectives of the Greater Thames Estuary Historic Environment Research Framework.
- To establish the location of any ‘islands’ that may have been favoured areas for activity in the past and their longevity.
- In the Mar Dyke valleys, to establish the sequence and character of deposits across the valleys, and date them by means of artefacts or scientific dating.
- To clarify the changing extent of the alluviated area over time, and look for evidence of agriculture, settlement or burials that might support the evidence of the sediments themselves.
- To look for buried archaeological horizons within the colluvial sequence.
- For the late Upper Palaeolithic, Mesolithic and Neolithic periods, to investigate Landscape Processes, and in particular, the potential for sites being eroded and buried beneath colluvium or Head deposits at the foot of slope areas (Aims C.6 and C.7), and for the survival of undisturbed occupation surfaces below colluvium, or beneath later alluviation in the Mar Dyke and Thames floodplains.
- To investigate activity carried out around causewayed enclosures and burial monuments of the Neolithic and early Bronze Age, whether peripheral burial, deposits related to visits, or reuse for burial or other purposes in later periods.
- To clarify whether the cropmarks provide an accurate representation of the range, quantity and types of archaeological features present within the parcel.
- To establish the character and date of the extensive pits across the land parcel, and to determine whether these are all of one type or period, or whether they encompass several types and span several periods of activity.



- To establish the extent, character and density of Roman activity within the scheme area, and in particular, whether the undated cropmark enclosures are Roman, and if so, establish their duration of use.
- To determine whether further evidence of pottery production is present within the scheme area, and if so, to date and characterise this.
- To look for evidence of the projected Roman roads within the scheme area, and in particular where the roads are believed to cross the northern Mar Dyke valley and the dry valley at the south end of the scheme, where preservation may prove to be good.
- To look for evidence of medieval and post-medieval farmsteads which may have been located along the roadways to the east and west of the land parcel.

## 3 Methodology

---

### 3.1 Constraints

- 3.1.1 Overhead power lines limited the area of the site available for trial trenching. These comprised two parallel, WNW-ESE-aligned overhead lines, which bisected the centre of the land parcel. In addition, an Anglian Water surface waterpipe bisected the eastern part of the land parcel, a telecoms line ran along Brentwood Road and a high voltage line ran along the western boundary of the land parcel, branching off and bisecting the north-western part of the site next to Brook Farm. There were also several irrigation channels in the north-western corner of the land parcel, which constrained the placing of trenches. Additionally, there were two ecological constraints, one located within the eastern part of the land parcel and one subsidiary constraint located along the northern boundary, each of which required a 30m buffer zone.
- 3.1.2 These limitations were considered when designing the detailed trench layout and the locations of approximately 30 trenches were adjusted; however, seven trenches were completely abandoned due to the constraints of the exclusion zones placed around the overhead lines.

### 3.2 Methodology for the evaluation

- 3.2.1 The total land parcel area was 32.59ha, and the area available for investigation excluding areas of services, hedgerows and other constraints was 30.63ha. The archaeological trial trenching comprised a total of 160 trenches, with 153 trenches measuring 30m x 2m, one trench (Trench 77) measuring 22.5m x 22.7m, one trench (Trench 83) measuring 15m x 2m, one trench (Trench 96) measuring 50m x 2 m, one trench (Trench 102) measuring 35m x 2m, one trench (Trench 117) measuring 15m x 10m, one trench (Trench 146) measuring 40m x 2m and one trench (Trench 148) measuring 28m x 2m. Combined, these represent a 3.55% sample of the area available for trenching. The location of the trenches is shown on Figure 2.
- 3.2.2 The trench design was developed to target cropmark features identified by the aerial investigation and mapping report (Place Services 2019), and otherwise to provide even coverage of the blank areas. Trenches 17, 18, 20, 21, 22, 23, 27, 34, 35, 48, 79, 80, 86, 95, 96, 98, 100, 102, 118, 134, 135, 136 and 139, targeted linear cropmark features. Trenches 49, 50, 76, 77, 78, 83, 84, 103, 105 and 117 targeted possible discrete features (Fig. 2).
- 3.2.3 All trenches were located using a Global Positioning System (GPS) prior to machine excavation. All trenches were excavated using a tracked excavator fitted with a toothless bucket under constant archaeological supervision.
- 3.2.4 Revealed features were hand cleaned and sampled by hand excavation. They were recording as outlined within the approved WSI. All finds were

bagged by context throughout the evaluation and were recovered for further investigation.

## 4 Results

---

### 4.1 Introduction and presentation of results

- 4.1.1 The results of the evaluation are presented below and include a stratigraphic description of the trenches that contained archaeological remains. The full details of all trenches with dimensions and depths of all deposits can be found in Appendix A. Finds data are tabulated in Appendix B.
- 4.1.2 Context numbers reflect the trench numbers, unless otherwise stated. For example, ditch 803 is a cut within Trench 8, while pit 1719 is a cut within Trench 17.
- 4.1.3 An overview of the results for the site is shown on Figure 2. Further detailed plans of the trenches which contained archaeological features are shown on Figures 3-10 and selected sections are shown on Figures 11 and 12.

### 4.2 General soils and ground conditions

- 4.2.1 The soil sequence varied across the site: on the east and north exposed slope, the silt and sand deposits of the Thanet Formation are overlain by Pleistocene solifluidal slope deposits (locally over 1.0m thick). In the western part of the area adjacent to the Boyn Hill Gravel Member lenses of solifluidal clayey sandy gravel up to 0.3m thick form the base of the slope deposit. Isolated deposits of Holocene colluvium, up to 0.9m thick, occur locally on lower slope positions at the eastern edge of the area.
- 4.2.2 The topsoil comprised a dark grey brown silty clay or silty sand plough soil, which was generally 0.2-0.4m thick.
- 4.2.3 Ground conditions throughout the evaluation were very challenging, and the site remained waterlogged throughout. Archaeological features, where present were challenging to identify against the underlying geology of hillslope deposits.

### 4.3 General distribution of archaeological deposits

- 4.3.1 Archaeological features were located in Trenches 8, 9, 14, 17, 18, 20, 21, 22, 24, 25, 26, 27, 28, 29, 30, 34, 35, 36, 41, 44, 46, 47, 50, 51, 52, 53, 54, 55, 56, 58, 59, 60, 61, 64, 68, 69, 71, 74, 76, 77, 78, 79, 84, 85, 86, 87, 88, 90, 91, 92, 94, 95, 96, 98, 99, 100, 103, 107, 111, 112, 113, 114, 115, 117, 118, 119, 120, 121, 122, 123, 129, 131, 134, 135, 136, 138, 139, 140, 141, 142, 146, 147, 149, 150, 151, 152, 153, 155, 159, 164 and 165.
- 4.3.2 The evaluation confirmed the presence of several linear and curvilinear features within the site, which had been identified as cropmarks by the aerial investigation and mapping report (Place Services 2019). The features included 2005, 2105, 2717, 3505, 8401, 9503, 9505, 9602, 9802, 9806, 10205, 11902, 13402 and 13914.

## 4.4 Trench 17 (Fig. 9)

- 4.4.1 Trench 17 was located at the central-western end of the site immediately to the north and west of cropmarks aligned on modern field boundaries. The trench contained several pits and ditches, including the terminal of a ditch (1709). This was orientated NE-SW, measured 1.24m in width by 0.44m in depth and contained three fills (Fig. 10 Section 1703). The uppermost fill produced eight sherds of late Bronze Age to Iron Age pottery and some burnt flint, alongside charcoal, charred hazelnut shell and charred weed seeds.

## 4.5 Trench 21 (Fig. 2)

- 4.5.1 Trench 21, located at the western end of the site, contained three E-W orientated ditches (2103, 2105 and 2107). Ditch 2103 measured 3.6m in width by 0.34m in depth, ditch 2105 measured 1.8m in width by 0.58m in depth, and ditch 2107 measured 2.01m in width by 0.2m in depth. All three ditches contained single fills, the fill of ditch 2103 producing two fragments of 16th to 18th century roof tile.

## 4.6 Trench 24 (Fig. 2)

- 4.6.1 Trench 24, located close to the central western edge of the site, contained a N-S-orientated linear ditch (2403), which measured 1.53 m in width by 0.23m in depth and containing two fills, the upper of which produced a single sherd of sandy oxidised Roman pottery. A sub-circular pit (2406) was immediately to the east of the ditch. It measured 0.65m in diameter and 0.36m in depth and contained two fills.

## 4.7 Trench 26 (Fig. 9)

- 4.7.1 Trench 26 located towards the central western end of the site contained two large pits dating to the 12th to 13th centuries and probably representing sand or gravel extraction pits.
- 4.7.2 Pit 2604 was irregular in plan. It extended beyond the edge of excavation to the north and measured 1.02m in width by 0.41m in depth. The feature contained a single fill, which produced two sherds of pottery dated AD 1100-1250 and a single fragment of fired clay oven/hearth furniture.
- 4.7.3 Pit 2606 was sub-circular, measured 1.06m in diameter by 0.33m in depth and contained two fills, the upper of which produced two sherds of pottery dating to AD 1140-1220.

## 4.8 Trench 41 (Fig. 2)

- 4.8.1 Trench 41, in the central western part of the site, revealed a subsoil overlying a pit and a plough-furrow.
- 4.8.2 Subsoil 4101 comprised a yellowish brown silty-sand 0.15m thick. Some 66 sherds of middle Bronze Age pottery were recovered.
- 4.8.3 Sub-circular pit 4107 was located between two unexcavated natural features. It measured 0.55m in diameter by 0.23m in depth and contained a single fill, which produced a single sherd of middle Bronze Age pottery with cordon and fingernail decoration.

## 4.9 Trench 47 (Fig. 4)

- 4.9.1 Trench 47 in the south-central part of the site contained a single sub-circular pit (4703). It measured 0.72m in diameter by 1m in depth and extended beyond the eastern edge of excavation. It contained five fills of sandy silt mixed with charcoal and worked flint. The pit fills contained the remains of two late Neolithic to early Bronze Age Beaker vessels, seemingly deposited one on top of the other, the lower vessel being comb decorated, the upper vessel having incised decoration. Both of the fills containing Beaker pottery also contained fired clay, along with large quantities of charcoal, which was also very frequent in the basal fill. In addition, there was a single sherd of sandy oxidised Roman pottery from an upper fill overlying and sealing the Beaker material.

## 4.10 Trenches 61, 64, 68 and 69 (Fig. 2)

- 4.10.1 Trenches 61, 64, 68 and 69 located from west to east along the central northern edge of the site all produced flint-tempered pottery of late Bronze Age or Iron Age date, mostly from colluvial layers (6102, 6405, 6406 and 6804), but in the case of Trench 69 from the fill of pit 6903. This suggests a concentration of late Bronze Age or Iron Age activity in this area. However, there are no associated cropmarks and the excavated archaeology is relatively uninformative. Slope deposits from Trench 64 (6407) also produced a single rim sherd from a Roman jar or bowl.
- 4.10.2 Colluvial layer 6102 in Trench 61 comprised a light grey sandy silt 0.16m thick, which produced six sherds of late Bronze Age to Iron Age pottery.
- 4.10.3 Colluvial layers 6405 and 6406 in Trench 64 comprised mid-yellowish brown/brown sandy silts 0.36m and 0.24m thick respectively, which produced eight sherds of late Bronze Age to Iron Age pottery. Layer 6405, which also produced a late Mesolithic backed bladelet, was cut by undated ditch 6404 orientated NE-SW. This containing two fills and measured 0.9m wide and 0.32m deep.
- 4.10.4 Colluvial layer 6804 consisted of a grey sandy silt 0.25m thick, which produced a large assemblage of 222 sherds of late Bronze Age to Iron Age pottery, alongside a small quantity of charcoal, some charred weed seeds and 64 fragments of flint. No features were recorded in this trench.
- 4.10.5 Sub-circular pit 6903 in Trench 69 was 0.84m in diameter and 0.3m deep and contained a single fill, which produced eight sherds of late Bronze Age to Iron Age pottery.

## 4.11 Trench 94 (Fig. 3)

- 4.11.1 Trench 94 in the central southern part of the site exposed a pit (9402). The pit was subcircular in plan and measured 0.84m in diameter and 0.3m in depth (Fig. 10 Section 2400). It contained a single fill, which produced 31 sherds of late Bronze Age to Iron Age pottery, along with 29.3g of burnt human bone. The bone was identified as the cremated remains of a probable adult of indeterminate sex. A small quantity of heavily damaged and vitrified grain, charred weed seeds and a charred legume was also recovered.

## 4.12 Trench 107(Fig. 3)

- 4.12.1 Trench 107 near the south-central boundary of the site contained a group of seven pits or tree-throw holes (10719, 10704, 10707) and (10717, 10713, 10715 and 10710) in two parallel lines, orientated NW-SE. The features were all broadly sub-circular in plan but varied widely in size from 0.13m to 1.54m wide and 0.09m to 0.36m deep (Fig. 10 Sections 10702 and 10703). All had one or two fills. Tree-throw 10710 produced a flint burin, or fragment from a complex core of probable early prehistoric date, while pit 10704 produced an early prehistoric flint blade. Pit 10715 produced deposits of burnt unworked flint, along with a large quantity of charcoal and charred weed seeds. Taken together this group of features possibly represents Neolithic or early Bronze Age occupation.

## 4.13 Trench 111 (Fig. 7)

- 4.13.1 Trench 111, located close to the south-central edge of the site, contained two features.
- 4.13.2 Ditch 11103 was orientated NW-SE and measured 1.12m in width and 0.23m in depth (Fig. 10 Section 11100). It contained a single fill, which produced a single flint flake of indeterminate date.
- 4.13.3 Pit 11105 measured 2.14m long, 1m wide and 0.14m deep (Fig. 10 Section 11101). It also contained a single fill, which produced a single sherd of late Bronze Age to Iron Age pottery, a single fragment of burnt unworked flint, charcoal, charred weed seeds and a legume, and snail shells.

## 4.14 Trench 119 (Fig. 6)

- 4.14.1 Trench 119, located at the western limit of the south-western spur of the site, contained two ditches (11902 and 11906) and posthole (11904).
- 4.14.2 Ditch 11902 was orientated N-S and measured 1.1m wide and 0.28m deep (Fig. 10 Section 11900). It contained a single fill, which produced two fragments of animal bone from a large mammal. The feature was associated with a linear cropmark extending northwards from the trench.
- 4.14.3 Ditch 11906 was orientated N-S and measured 0.74m wide and 0.26m deep (Fig. 10 Section 11901). It contained a single fill, which produced six sherds of middle to late Bronze Age pottery. The ditch cut the fill (11905) of posthole 11904, which was subcircular in plan and measured 0.4m in diameter and 0.21m in depth. It was filled with a single sterile deposit.
- 4.14.4 Despite the fact that the ditches are parallel and similar in appearance, the linear cropmark associated with ditch 11902 appears to terminate at its intersection with a second set of cropmarks to the north, which are aligned on the modern field boundary and need not be Bronze Age in date.

## 4.15 Trenches 122, 123 and 131 (Fig. 2)

- 4.15.1 Trenches 122, 123 and 131, located along the north-eastern boundary of the site, appear to represent a continuation of the activity seen in Trenches 61-69.
- 4.15.2 Trench 122 contained a layer of colluvium comprising light grey sandy silt 0.5m thick, which produced six sherds of late Bronze Age to Iron Age pottery.
- 4.15.3 Subsoil 12301 from Trench 123 consisted of orangish brown sandy silt 0.5m thick, which produced a single sherd of late Bronze Age to Iron Age pottery. The subsoil layer sealed several layers of colluvium and a ditch (12306), which was orientated NE-SW and measured 0.67m wide and at least 1.1m in depth. The ditch was filled by three deposits, though none contained finds and so the feature remains undated.
- 4.15.4 Pit 13104 in Trench 131 was recorded in section only and measured 1.6m wide and 0.89m deep. It contained three fills, the uppermost of which produced two sherds of late Bronze Age to Iron Age pottery and two worked flint flakes. An unexcavated and undated sub-circular pit (13108) was also recorded in the trench.

## 4.16 Trenches 134, 135, 136 and 139 (Fig. 5)

- 4.16.1 Trenches 134, 135, 136 and 139 were located towards the south-eastern end of the site to investigate a cropmark apparently defining part of a sub-rectangular enclosure. Of the four trenches, Trenches 134 and 139 revealed parts of the enclosure ditch and a substantial amount of pottery, mostly from Trench 139 and mostly dating to the middle Bronze Age. Trenches 135 and 136 revealed undated features possibly associated with the putative enclosure.
- 4.16.2 Trench 134 revealed a ditch (13402), which was aligned NW-SE with the cropmark. The feature measured 1.56m in width and 0.48m in depth and



contained three fills (Fig. 10 Section 13400), the upper of which produced a single sherd of flint-tempered pottery of late Bronze Age to Iron Age date and a worked flint flake.

- 4.16.3 Trench 135 contained a single unexcavated ditch (13503), orientated NE-SW on the line of a post-medieval boundary shown on the first edition Ordnance Survey map, and also seen in Trench 139 to its north-east.
- 4.16.4 Trench 136 coincided with a gap in the cropmark, possibly representing an entrance, and revealed two small ditches (13603 and 13607), which did not coincide with the line of the cropmark, along with a small pit (13605). A probable treehole (13610) was recorded partly where the cropmark, or entrance, was aligned. Ditch 13603 measured 1.08m in width by 0.28m in depth and contained a single fill producing eight sherds of flint-tempered pottery of late Bronze Age to early Iron Age date (Fig. 11 Section 13600). Ditch 13607 measured 1.01m in width and 0.3m in depth and contained a single fill (Fig. 11 Section 13602), which produced three sherds of late Bronze Age to Iron Age date. Undated sub-circular pit 13605 measured 0.57m in diameter, by 0.21m in depth and contained a single fill (Fig. 11 Section 13601).
- 4.16.5 Trench 139 was positioned towards the south-eastern end of the cropmark enclosure. Curvilinear ditch 13914 was aligned NW-SE, with the cropmark, at its southern end, then turned to the north-east and extended beyond the edge of excavation. The ditch measured 0.73m in width by 0.38m in depth and contained a single fill, which produced 150 sherds of middle Bronze Age pottery representing most of a freshly broken bucket urn (Fig. 11 Section 13903).
- 4.16.6 Ditch 13906, located to the south of ditch 13914, was orientated NE-SW and extended along the south-western half of the trench. It measured 0.86m wide and 0.2m deep (Fig. 11 Section 13901). The feature contained two fills. The lower fill produced a late Neolithic to early Bronze Age flake. The upper fill contained four sherds of pottery, also from a bucket urn and encrusted with carbonised cooking residue, along with a single sherd of late Bronze Age to Iron Age pottery and a large quantity of charred barley grains.
- 4.16.7 Ditch 13906 was cut at its north-eastern end by post-medieval ditch 13909, orientated SW-NE and aligned with a boundary shown on the first edition Ordnance Survey map. The ditch measured 1.26m wide and 0.44m deep and contained two fills.

## 4.17 Trench 147 (Fig. 2)

- 4.17.1 Trench 147, located towards the south-western end of the site, produced a single sherd of post-medieval pottery, which was recovered from the topsoil (14700), a mid-brown silty clay. The trench also contained two undated ditches (14703 and 14705) orientated NE-SW. The latter produced a single piece of undated worked flint.

## 4.18 Trenches 152, 153, 155 (Fig. 8) and 164 (Fig. 2)

- 4.18.1 Trenches 152, 153, 155 and 164, located in the south-eastern spur of the site, to the north-west of Hoford Road, exposed several linear ditches and,

in the case of Trench 155, a dense concentration of features of prehistoric or Roman date.

- 4.18.2 Trench 152 contained two unexcavated NE-SW orientated ditches (15203 and 15204). A single sherd of flint-tempered late Bronze Age to Iron Age pottery was recovered from the surface of ditch 15203, while a single sherd of Roman pottery was collected from the surface of ditch 15204.
- 4.18.3 Trench 153 contained three broadly E-W orientated ditches, two of which (ditches 15303 and 15307) were clearly aligned with ditches 15203 and 15204 in Trench 152 and are presumably a continuation of those features. Ditch 15303, which represented a recut of ditch 15307, measured 1.18m in width by 0.52m in depth and contained a single fill (Fig. 11 Section 15300). This produced two sherds of Iron Age pottery, a single sherd of oxidised Roman pottery, the skull of a dog, an assemblage of charred weed seeds and two fragments of undated worked flint. Ditch 15307 measured 1m in width by 0.58m in depth and contained two fills. Ditch 15305 at the northern end of the trench measured 1.42m in width and 0.16m in depth and contained a single fill (Fig. 11 Section 15301), which produced a sherd of late Bronze Age to Iron Age pottery.
- 4.18.4 Trench 155 contained a group of 13 intercutting features comprising pits and ditches. The ditches (15516, 15513, 15518, 15520, 15523, 15528, 15535 and 15536) were all orientated NE-SW and ranged between 0.56m and 1.58m wide and between 0.28m and 0.4m deep (Fig. 11 Sections 15502, 15503 and 15505). Of these, three (15528, 15535 and 15536) were unexcavated. Interventions through the others showed that the ditches were filled by one or two deposits. The ditch fills were largely sterile. However, fills of ditches 15513 and 15518 produced fragments of large mammal bone, including red deer antler, while the fills of ditch 15523 produced a late Mesolithic rod microlith, and a worked flint flake. In addition, the fill of ditch 15518 produced a sherd of flint-tempered late Bronze Age to Iron Age pottery.
- 4.18.5 The pits (15503, 15506, 15508, 15511 and 15526), which were all sub-circular in plan, measured between 0.6m and 1.02m in diameter or width and between 0.16m and 0.5m in depth. They contained between one and two fills. The fills of pit 15508 produced 21 fragments of fired clay, the fill of pit 15506 produced a small fragment of iron bar, some charcoal and unworked burnt flint, and the fills of pit 15503 produced a small quantity of charcoal and charred weed seeds, along with a large quantity of burnt unworked flint.
- 4.18.6 Trench 164, which was situated at the far south-eastern corner of the site, contained a single pit (16403), which measured 1.22m in diameter and 0.36m in depth and contained three fills. The middle fill, which comprised a thin lens of charcoal-rich material, produced two sherds of flint-tempered late Bronze Age to Iron Age pottery, charcoal and a single charred wheat grain.

## 4.19 Trench 161 (Fig. 2)

- 4.19.1 Trench 161 was positioned in the south-eastern corner of the site. Subsoil 16101, a mid-orange brown sandy silt 0.5m thick, produced a single sherd of medieval pottery dating to 1270-1350.

## 4.20 Undated features (Fig. 2)

- 4.20.1 A number of undated archaeological features were identified within trenches 8,9,14,15, 20, 21, 22, 27, 28, 29, 30, 34, 35, 36, 44, 46, 50, 51, 52, 53, 54, 55, 56, 58, 59, 60, 71, 72, 74, 76, 77, 78,79, 80, 84,85, 86, 88, 90, 91, 95, 96, 98, 99, 100, 101, 102, 103,112, 113, 115, 118, 120, 122, 123, 129, 135, 138, 140, 141, 142, 146, 148, 149, 150, and 159. The undated features mostly comprise isolated linear ditches and pits, with occasional tree-throw holes and other natural features. Several were aligned on cropmarks, which appear to have taken their orientation from historic field boundaries shown on the first edition ordnance survey mapping. However, in general they do not appear to reflect any particular patterns of activity and therefore will not be described in detail.

## 4.21 Finds summary

- 4.21.1 **Prehistoric pottery.** Some 576 sherds (6099g) of prehistoric pottery were recovered from 28 contexts across 21 trenches. Three distinct periods were represented: the late Neolithic/early Bronze Age (Beaker; c 2450-1850 cal BC), the middle Bronze Age (c 1600-1150 cal BC), and the late Bronze Age/iron Age (c 1150-50 cal BC). The majority of this last group should belong within the earlier part of the span.
- 4.21.2 **Roman pottery.** Five sherds of pottery, weighing 16g, were recovered from the evaluation. This very small assemblage consisted of sherds of sandy reduced oxidised ware of probable local origin. Only a single rim was recovered, and this was from a jar or bowl with an everted rim. None of the sherds could be dated more closely than to the Roman period (AD 40-410).
- 4.21.3 **Medieval and post-medieval pottery.** Six sherds of medieval and post-medieval pottery weighing 93g were recovered from four contexts. Ordinary domestic wares dating to the 12th, 13th, 14th and 19th centuries were recovered.
- 4.21.4 **Fired clay.** A small quantity of fired clay amounting to 67 fragments weighing 227g was recovered from trenches 26, 47 and 155. The assemblage consists of small, poorly preserved abraded material with a very low mean fragment weight of 4g. The fired clay cannot be dated and is reliant on associated dateable material for its phasing. The majority of pieces were amorphous and of indeterminate form, though likely to derive from oven or hearth structure.
- 4.21.5 **Ceramic building materials.** A small quantity of ceramic building material (CBM) amounting to seven fragments weighing 335g was recovered from ditch fills in trenches 21, 86, 95 and 98. The material is all of post-medieval date.
- 4.21.6 **Metals.** There are six metal finds, all of iron or cast iron. These comprise: an iron plate of trapezoid shape with three nail or rivet holes towards one end, probably from a waggon or from a piece of farm machinery; a cast-iron plough share, probably of 20th-century date; a small corroded undated piece of iron sheet; a nail with a regular flat circular head, probably recent in date; an iron batten ring probably of 18th-century date; and a small piece of undated iron bar.
- 4.21.7 **Worked Stone.** A single piece of stone was retained. This is a small fragment of ferruginous sandstone weighing 51g. It has a possible worked surface and could be part of a quern but is too small for this function to be confidently assigned.
- 4.21.8 **Flint.** A moderate assemblage of 113 struck flints and 725 fragments of burnt unworked flint, weighing 3456g, was recovered from this evaluation. The struck flint was widely dispersed across the evaluation area, generally in quite low numbers, but one Beaker-period pit (Pit 4703) yielded 46 flints. The assemblage was largely flake-based, but despite this, a number of diagnostic early prehistoric flints, including a burin, end truncation and a

pair of late Mesolithic microliths were recovered as stray finds in later contexts. This indicates a limited early prehistoric presence, with the potential for denser flint-rich contexts as well as possible additional pits to be encountered should any further works commence.

## 4.22 Environmental summary

- 4.22.1 **Charred plant remains and charcoal.** Twenty-two samples were taken from the evaluation. The samples indicate good potential for the recovery of charred material on site. Preservation of material usually ranges from fair to good. Recovered material offers some insights into subsistence on site as both hazelnut and goosefoots such as fat hen (*Chenopodium album*) were utilized as food resources during the Neolithic and use could have continued into the later prehistoric periods. We also have evidence of barley being cultivated in the Bronze Age and evidence of cereals continues into the Iron Age. This presents an opportunity to investigate changing subsistence practices from the end of the Neolithic through to the Iron Age.
- 4.22.2 **Animal bone.** A total of 160 animal bone specimens were recovered from the site. Dated animal bone assemblages came from features belonging to the late Bronze Age/Iron Age periods. Preservation on the site was very poor, likely to be due to acid soils and water percolation. No doubt this affected the size of the recovered assemblage and also the proportion which could be identified. The specimens that could be identified consisted of red deer (*Cervus elaphus*) antler from late Bronze/Iron Age ditch 15518 and several dog (*Canis familiaris*) specimens from late Bronze Age/Iron Age ditch 15303.
- 4.22.3 **Human remains.** One deposit (fill 9403 of pit 9402) containing burnt human bone was recovered during the evaluation. The total bone weight was 29.3g and was identified as a probable adult of indeterminate sex. Overall, bones were well burnt. No pathology was observed. The total weight of bone was well below the expected range (600-900g) for archaeologically recovered cremation burials (McKinley 2013, 154). The very low bone weight combined with the high charcoal content of the matrix and dimensions of pit 9402 make it highly unlikely that it was a formal unurned cremation burial. It is more likely that 9403 was redeposited pyre debris or another form of cremation related deposit. The burnt bone was unurned and is currently undated.

## 5 Discussion

---

### 5.1 Reliability of field investigation

- 5.1.1 The archaeological features were poorly defined against the underlying Boyn Hill Gravels, Thanet Sands and Gravels and hill slope deposits, and several deposits were sample excavated to establish if they were of geological or archaeological significance. In several examples, putative archaeological features were shown to be no more than variations in natural deposits of sand or gravel. Along the northern edge of the site, where the hill slope deposits were particularly deep several trenches contained archaeological features that were impossible to observe in plan, which were therefore only recovered in section after machining.
- 5.1.2 There was a correlation between the aerial survey cropmarks and the archaeological features in Trenches 17, 20, 21, 27, 34, 35, 50, 53, 54, 77, 78, 79, 80, 84, 85, 95, 96, 98, 102, 103, 117, 118, 134, 136 and 139. These correlations included linear features 2005, 2105, 2717, 3505, 5004, 7907, 8005, 8503, 9503, 9505, 9602, 9802, 9806, 10303, 10305, 13402 and 13914. In addition, the correlations also included discrete features: 5303 and 5403 (containing some burnt unworked flint), and possibly sub-circular features 7707, 7709, 7711, 7713 and 11703, along with curvilinear feature 8401, which was correlated with the cropmark of a possible ring-ditch. Significantly, the linear features excavated in Trenches 134, 136 and 139 appear to have formed part of a sub-rectangular enclosure represented by cropmarks.
- 5.1.3 The discrete features identified as cropmarks in Trenches 22, 23, 48, 49, 56, 83, 100, 101, 103, 105, 106, 108, 112, 114 and 117 were not identified during the excavation. It is likely that the discrete features in the other trenches were all natural features and this possibility is discussed further below in Section 5.2.
- 5.1.4 The northern part of the site contained previously unidentified areas of sparse archaeological features in Trenches 9, 14, 15, 17, 18, 61, 64, 69, 71, 87, and 88 of which six contained late Bronze Age to early Iron Age pottery (Trenches 17, 61, 64, 69, 123 and 131). The eastern part of the site also contained several previously unidentified archaeological features in Trenches 132, 140, 141, 146, 147, 148, 149 and 165 and one trench (Trench 155) close to the eastern limit of the site which contained a dense concentration of linear features and pits, containing occasional sherds of late Bronze Age to Iron Age pottery. The southern part of the site also contained a scatter of previously unidentified archaeological features in trenches: 29, 36, 41, 46, 47, 52, 55, 58, 60, 94, 99, 107, 111, 115, 120, of which Trench 107 produced two groups of possibly Neolithic/early Bronze Age pits or tree-throw holes containing worked flint, Trenches 41, 46 and 47 produced middle Bronze Age and Beaker pottery, Trench 94 produced a pit containing cremated human remains dated to the late Bronze Age/early Iron Age and Trench 111 produced late Bronze Age/Iron Age pottery. It is likely that the absence of archaeological remains elsewhere in the site reflects an absence of archaeological activity in these areas.

## 5.2 Interpretation

- 5.2.1 **Mesolithic/Neolithic.** One hundred and thirteen worked flints and 725 fragments of burnt unworked flint were found across the site. The majority of this material was widely dispersed, often from ploughsoil, in generally quite low numbers and the assemblage was largely flake based. However, there were a number of diagnostic early prehistoric flints attesting to limited late Mesolithic and early Neolithic activity, as well as the potential for denser activity foci of these dates. The two late Mesolithic microliths were widely dispersed in Trenches 64 and 155. However, both were located towards the northern and eastern sides of the site, on lower lying ground close to the base of a dry valley, and perhaps therefore suggest Late Mesolithic activity along the water course. In addition, one group of features from Trench 107, including pits 10704, 10713 and 10716 and tree-throw hole 10710 seems likely to have represented a focus of Neolithic or early Bronze Age occupation.
- 5.2.2 **Late Neolithic/Early Bronze Age.** A single small sub-circular pit (4703) from Trench 47 in the central southern part of the site produced 31 sherds of late Neolithic to early Bronze Age Beaker pottery, representing the remains of at least two distinct vessels, along with large quantities of charcoal, 46 worked flints including flakes, blades and scrapers and some fired clay. The pit was isolated in an area of the site that was otherwise devoid of archaeological features. However, it was situated just to the south of an area of relatively dense undated linear and discrete cropmarks, which were largely not correlated with visible features in the trial trenches. The nature of the assemblage, comprising remains of two vessels, flint tools and charcoal, suggests domestic rather than funerary activity, although the presence of the charcoal and the nearby presence of the cropmarks of ring-ditches might be taken to indicate funerary activity. However, the absence of human remains from the feature argues against the latter scenario.
- 5.2.3 **Middle Bronze Age.** Two sections of linear ditch from trenches 134 and 139 in the north-eastern corner of the site correlated with a cropmark representing a sub-rectangular enclosure. A small quantity of pottery from the ditch within Trench 134 dated to the late Bronze Age to Iron Age period and two ditches from Trench 139, including ditch 13914 (which correlated with the cropmark), produced a substantial assemblage of middle Bronze Age pottery, with carbonised cooking residue preserved on some of the sherds, suggesting domestic activity. The nature of the enclosure is difficult to determine, however, with a scatter of isolated linear features from the interior being of indeterminate function. Nevertheless, the later pottery from the linear feature in Trench 134 and additional smaller quantities of middle Bronze Age pottery from the second ditch in Trench 139, which was not correlated with any cropmark, indicate that the enclosure was relatively long-lived and perhaps underwent some remodelling during its lifespan.
- 5.2.4 **Late Bronze Age to Iron Age.** Scattered linear and discrete features from trenches along the northern edge of the site and in the central southern part of the site containing occasional sherds of flint and sand tempered

late Bronze Age to Iron Age pottery are suggestive of late Bronze Age to Iron Age settlement in these areas. A denser concentration of features from next to the eastern edge of the site, which also contained very small quantities of late Bronze Age to Iron Age pottery was perhaps part of a larger scatter of activity of this date in this area. However, they may also have belonged to the Roman period.

- 5.2.5 **Roman.** A group of five small and heavily abraded sherds of Roman pottery widely distributed across the site suggest that Roman period activity was very limited indeed and probably restricted to agricultural activity, or occasional visits for the harvesting of natural resources. Despite this, the presence of two Roman sherds from the concentration of features in Trench 152 and 153 could indicate that this activity was Roman in date.
- 5.2.6 **Medieval** activity was restricted to two pits from Trench 26 in the western part of the site which probably represent quarrying for gravel or brickearth.
- 5.2.7 **Post-medieval.** A curvilinear cropmark, which partly cuts across the southern spur of the site, appears to be part of a field boundary marked on the first edition ordnance survey map. In addition, other undated linear cropmarks at the western end of the site orientated both SW-SE and NE-SW appear to be aligned on field boundaries marked on the first edition ordnance survey map.
- 5.2.8 **Geological and natural features.** The site contained a large number of discrete sub-circular features, between 1m and 3m in diameter, which were identified as cropmarks and were targeted in Trenches 24, 28, 30, 48, 49, 50, 53, 54, 56, 76, 77, 78, 83, 84, 100, 101, 103, 105, 106, 107, 108 and 117. Natural features, including tree-throw holes were identified within trenches 9, 25, 29, 41, 44, 50, 55, 71, 74, 76, 77, 78, 79, 86, 90, 100, 107, 115, 120, 123, 136 and 137. Several of these may be the same features identified as discrete cropmark features by the aerial survey. The rest of the discrete cropmarks were not identified.

### 5.3 Evaluation objectives and results

- 5.3.1 This evaluation established the presence of archaeological remains of late Mesolithic, Neolithic, late Neolithic/early Bronze Age, middle Bronze Age, late Bronze Age to Iron Age, Roman, medieval and post-medieval date and investigated their character by analysing their relationship to cropmark evidence, artefacts and environmental evidence. The evaluation also tested the cropmark evidence as identified by the 2019 aerial survey (Place Services 2019) and investigated the apparently blank areas where no cropmarks had been identified.
- 5.3.2 The evaluation was conducted within the general research parameters and objectives defined by the revised East of England Research Framework (Medlycott 2011). The aims and objectives outlined in the WSI were devised in line with those of the Greater Thames Estuary Historic Environment Research Framework. Therefore, where the WSI aims have been fulfilled it also follows that those within the regional research framework have also been addressed. These results are, of course, set



within the limitations of an evaluation where detailed interpretations are often difficult to apply with confidence.

- 5.3.3 In terms of specific objectives, the evaluation did not establish the location of any 'islands' favoured for past human activity within the land parcel.
- 5.3.4 The evaluation established the presence of colluvial sediments within the land parcel, but did not find any evidence of buried archaeological horizons within them.
- 5.3.5 Apart from the two microliths discussed in section 5.2.1 above, the evaluation did not encounter any evidence for Upper Palaeolithic, Mesolithic, or Neolithic sites buried beneath colluvium or Head deposits at the foot of the slope deposits along the northern edge of the site or discover any evidence for undisturbed occupation deposits of this date below colluvium.
- 5.3.6 The evaluation did not definitively establish the presence of any Neolithic or early Bronze Age burial monuments. However, the evaluation did investigate a late Neolithic to early Bronze Age pit containing Beaker pottery and frequent charcoal and a feature identified as a ring-ditch through cropmark evidence, although the latter investigation did not produce any dating evidence.
- 5.3.7 The evaluation clarified that, on the whole and with the exception of the discrete features the cropmarks, provided an accurate representation of the range quantity and types of archaeological features present within the land parcel.
- 5.3.8 The evaluation found evidence for a probable middle Bronze Age sub-rectangular enclosure at the western end of the site and a scatter of late Bronze Age to Iron Age activity along the northern edge of the site and in the southern part of the site, including one cremation burial.
- 5.3.9 The extensive number of pits identified as cropmarks within the central and western part of the land parcel are clearly of geological origin. The exact process which formed these features is not confirmed, although several of these features may be due to the variation in the Boyn Hill sand and gravels.
- 5.3.10 The evaluation found very little evidence for any Roman activity, no evidence for Saxon activity and evidence for medieval activity was restricted to two probable quarry pits for gravel and/or sand extraction.
- 5.3.11 The NNW-SSE and NE-SW cropmarks recorded as ditches 2005 and 2105, and 2717 and 3505 at the western end of the site are aligned on the field boundaries shown on the first edition Ordnance Survey map, as is the double ditch running along the central-southern boundary of the site. This suggests that these ditches are post-medieval in date.
- 5.3.12 No evidence of medieval driveways or medieval and post-medieval farmsteads were identified within the site.

## Appendix A Trench Tables

Trench 1							
General description					Orientation		NE-SW
Trench devoid of archaeology. Consisted of ploughsoil and subsoil overlying natural geology of sand and gravel.					Length (m)		30
					Width (m)		2
					Avg. depth (m)		1
Context No.	Type	Fill Of	Width (m)	Depth (m)	Description	Finds	Date
100	Layer			0.3	Ploughsoil. Dark grey brown, sandy silt		
101	Layer			0.7	Colluvial Layer. Geo-arch description may vary. Mid orange brown, sandy silt.		
102	Layer				Natural. Mid brown orange, clayey sand		
103	Void						

Trench 2							
General description					Orientation		NE-SW
Trench devoid of archaeology. Consisted of ploughsoil and subsoil overlying natural geology of sand and gravel.					Length (m)		30
					Width (m)		2
					Avg. depth (m)		0.75
Context No.	Type	Fill Of	Width (m)	Depth (m)	Description	Finds	Date
200	Layer			0.23	Ploughsoil. Dark grey brown, sandy silt		
201	Layer			0.32	Subsoil. Mid orange brown, clayey silt, moderately compact		
202	Layer				Natural. Mid brown orange, clayey gravelly sand		

Trench 3							
General description					Orientation		NW-SE
Trench devoid of archaeology. Consisted of Ploughsoil and subsoil overlying natural geology of sandy gravel.					Length (m)		30
					Width (m)		2
					Avg. depth (m)		0.8
Context No.	Type	Fill Of	Width (m)	Depth (m)	Description	Finds	Date
300	Layer			0.5	Ploughsoil. Firm, Dark greyish brown, silty clay.		
301	Layer			0.3	Subsoil. Soft, Mid yellowish brown, sandy silt		
302	Layer				Natural. Loose, Light yellowish orange brown, sandy gravel		
303	Layer		10.4	0.7	Colluvial Layer. Geo-arch description may vary. Mid orange brown, sandy silt.		

Trench 4							
General description					Orientation		NE-SW
Trench devoid of archaeology. Consisted of ploughsoil and subsoil overlying natural geology of sand and gravel.					Length (m)		30
					Width (m)		2
					Avg. depth (m)		0.73
Context No.	Type	Fill Of	Width (m)	Depth (m)	Description	Finds	Date
400	Layer			0.3	Ploughsoil. Firm, dark greyish brown, silty clay		
401	Layer			0.35	Subsoil. Soft, Mid orange brown, sandy silt, frequent gravel.		
402	Layer				Natural. Loose, Light yellowish brown, sandy gravel		

Trench 5							
General description					Orientation		NW-SE
Trench devoid of archaeology. Consisted of ploughsoil and subsoil overlying natural geology of sand and gravel.					Length (m)		30
					Width (m)		2
					Avg. depth (m)		0.7
Context No.	Type	Fill Of	Width (m)	Depth (m)	Description	Finds	Date
500	Layer			0.35	Ploughsoil. Firm dark greyish brown silt clay		
501	Layer			0.4	Subsoil. Soft, mid orange brown.sandy silt		
502	Layer				Natural. Loose,light orange brown, sandy gravel		
503	Layer		11	0.15	Colluvial Layer. Geo-arch description may vary. Mid brown orange silty sand.		

Trench 6							
General description					Orientation		
Not excavated. Trench located under low overhead power lines.					Length (m)		
					Width (m)		
					Avg. depth (m)		
Context No.	Type	Fill Of	Width (m)	Depth (m)	Description	Finds	Date

Trench 7							
General description					Orientation		NW-SE
Trench devoid of archaeology. Consisted of ploughsoil and subsoil overlying natural geology of sand and gravel.					Length (m)		30
					Width (m)		2
					Avg. depth (m)		0.69
Context No.	Type	Fill Of	Width (m)	Depth (m)	Description	Finds	Date
700	Layer			0.26	Ploughsoil. Dark grey brown, sandy clay		
701	Layer			0.42	Subsoil. Mid orange brown, clayey silt		
702	Layer				Natural. Mid orange brown, clayey gravelly sand		

Trench 8							
General description					Orientation		SW-NE
Trench revealed one ditch. Trench consisted of ploughsoil and subsoil overlying natural geology of sand and gravel.					Length (m)		30
					Width (m)		2
					Avg. depth (m)		0.4
Context No.	Type	Fill Of	Width (m)	Depth (m)	Description	Finds	Date
800	Layer			0.25	Ploughsoil. Firm, dark greyish brown, silty clay		
801	Layer			0.3	Subsoil. Soft, mid orange brown, sandy silt, frequent gravel		
802	Layer				Natural. Loose, Light yellowish brown, sandy gravel		
803	Cut		1.09	0.55	Ditch. Terminus		
804	Fill	803	0.3	0.08	Primary Fill. Light brownish red, gravelly sand, soft		
805	Fill	803	1	0.55	Secondary Fill. Light brownish grey, silty sand, soft.		

Trench 9							
General description					Orientation		E-W
Trench revealed a ditch terminus and a natural feature. Consisted of ploughsoil and subsoil overlying natural geology of sand and gravel.					Length (m)		30
					Width (m)		2
					Avg. depth (m)		0.3
Context No.	Type	Fill Of	Width (m)	Depth (m)	Description	Finds	Date
900	Layer			0.2	Ploughsoil. Dark grey brown, clayey silt		
901	Layer			0.1	Subsoil. Mid orange brown, clayey silt		
902	Layer				Natural. Mid brown orange, gravelly silty sand		

903	Cut		0.6	0.25	Natural Feature. Either tree throw hole or change in geology		
904	Fill	903	0.6	0.25	Primary Fill. Light greyish brown, silty sand, soft		
905	Cut		1.9	0.55	Ditch. Terminus, field boundary?		
906	Fill	905	1.9	0.54	Secondary Fill. Light brownish grey, silty sand, soft. Moderate gravel, poorly sorted		
907	Unexcavated feature		0.6		Natural Feature. Tree throw hole or change of geology. Similar to 903		

Trench 10							
General description						Orientation	NE-SW
Trench devoid of archaeology. Consisted of ploughsoil and subsoil overlying natural geology of sand and silt.						Length (m)	30
						Width (m)	2
						Avg. depth (m)	0.62
Context No.	Type	Fill Of	Width (m)	Depth (m)	Description	Finds	Date
1000	Layer			0.25	Ploughsoil. Firm, dark greyish brown, silty clay		
1001	Layer			0.25	Subsoil. Soft, Mid orangey brown, sandy silt		
1002	Layer				Natural. Loose, Light orange brown, sandy gravel		

Trench 11							
General description						Orientation	E-W
Trench devoid of archaeology. Consisted of ploughsoil and subsoil overlying natural geology of sand and silt.						Length (m)	30
						Width (m)	2
						Avg. depth (m)	0.64
Context No.	Type	Fill Of	Width (m)	Depth (m)	Description	Finds	Date
1100	Layer			0.3	Ploughsoil. Firm, dark greyish brown, silty clay		

1101	Layer			0.45	Subsoil. Soft, Mid orangey brown, sandy silt		
1102	Layer				Natural. Loose, Light Orange brown sandy gravel		

Trench 12							
General description					Orientation		E-W
Trench devoid of archaeology. Consists of ploughsoil and subsoil overlying natural geology.					Length (m)		30
					Width (m)		2
					Avg. depth (m)		0.42
Context No.	Type	Fill Of	Width (m)	Depth (m)	Description	Finds	Date
1200	Layer			0.26	Ploughsoil. Dark grey brown, sandy silt		
1201	Layer			0.16	Subsoil. Mid orange brown, clayey silt, moderately compact		
1202	Layer				Natural. Mid orange brown, clayey gravelly sand, moderately compact		

Trench 13							
General description					Orientation		NE-SW
Trench devoid of archaeology. Consisted of ploughsoil and subsoil overlying natural geology of sand and gravel					Length (m)		30
					Width (m)		2
					Avg. depth (m)		0.5
Context No.	Type	Fill Of	Width (m)	Depth (m)	Description	Finds	Date
1300	Layer			0.3	Ploughsoil. Dark grey brown, clayey sand		
1301	Layer			0.2	Subsoil. Mid orange brown, clayey sand		
1302	Layer				Natural. Mid brown orange, clayey gravelly sand		

Trench 14							
General description					Orientation		N-S

Trench revealed one ditch terminus at Southern end of trench. Consisted of ploughsoil and subsoil overlying natural geology of sand and gravel.						Length (m)	30
						Width (m)	2
						Avg. depth (m)	0.34
Context No.	Type	Fill Of	Width (m)	Depth (m)	Description	Finds	Date
1400	Layer			0.23	Ploughsoil. Dark grey brown, sandy silt		
1401	Layer			0.1	Subsoil. Mid orange brown, clayey silt		
1402	Layer				Natural. Mid brown orange, gravelly silty sand		
1403	Cut		0.6	0.19	Ditch. Diffuse terminus.		
1404	Fill	1403	0.6	0.19	Secondary Fill. light greyish brown, silty sand, soft.		

Trench 15													
Trench devoid of archaeology. Consisted of ploughsoil and subsoil overlying natural geology of sand and silt.						Orientation	E-W						
						Length (m)	30						
						Width (m)	2						
						Avg. depth (m)	0.75						
						Context No.	Type	Fill Of	Width (m)	Depth (m)	Description	Finds	Date
						1500	Layer			0.25	Ploughsoil. Firm, Dark greyish brown, clayey silt		
1501	Layer			0.15	Subsoil. Soft, Mid orangey brown, sandy silt								
1502	Layer				Natural. Loose, mottled Light yellowish orange/yellowish white, sand with silt patches								
1503	Unexcavated feature		1.36	0.2	Ditch. Only seen in the SE facing baulk section. Fill is a mid orange brown, sandy silt.								
1504	Void												

Trench 16							
-----------	--	--	--	--	--	--	--



General description						Orientation	NE-SW
Trench devoid of archaeology. Consists of ploughsoil and subsoil overlying natural sand and gravels.						Length (m)	30
						Width (m)	2
						Avg. depth (m)	0.55
Context No.	Type	Fill Of	Width (m)	Depth (m)	Description	Finds	Date
1600	Layer			0.15	Ploughsoil. Firm, dark greyish brown, silty clay		
1601	Layer			0.4	Subsoil. Soft, mid orange brown, sandy silt		
1602	Layer				Natural. Loose/soft, Light yellowish brown, gravel sand		
1603	Void						

<b>Trench 17</b>							
General description						Orientation	E-W
Trench revealed 4 ditches, 3 pits and 3 unexcavated features. Consists of ploughsoil overlying the natural geology.						Length (m)	30
						Width (m)	2
						Avg. depth (m)	0.36
Context No.	Type	Fill Of	Width (m)	Depth (m)	Description	Finds	Date
1700	Layer			0.3	Ploughsoil. Dark grey, compact, clayey gravelly sand.		
1701	Layer				Natural. Orange-yellow friable gravel.		
1702	Cut		0.48	0.18	Ditch. Terminus		
1703	Fill	1702	0.48	0.18	Deliberate Backfill. Mid-greyish brown, friable/soft gravelly sand.		
1704	Cut		0.98	0.28	Ditch		
1705	Fill	1704	0.8	0.26	Secondary Fill. Mid-brown, soft, silty, gravelly sand.		
1706	Fill	1704	0.64	0.14	Deliberate Backfill. Greyish brown, friable silty, sandy gravel.		
1707	Cut		0.9	0.24	Ditch		

1708	Fill	1707	0.9	0.24	Deliberate Backfill. Mid-greyish brown, soft/friable, silty, gravelly sand.		
1709	Cut		1.24	0.44	Ditch. Terminus		
1710	Fill	1709	0.9	0.08	Primary Fill. Mid-brownish grey, friable, sandy gravel. Same as (1714).		
1711	Fill	1709	1.04	0.16	Secondary Fill. Light-grey, soft, silty sand. Same as (1715).	Flint	Neo/Neo-EBA
1712	Fill	1709	1.24	0.2	Secondary Fill. Light greyish brown, soft, silty sand. Same as (1716).	Pot, Flint	LBA/IA
1713	Cut		0.7	0.46	Ditch. Same as [1709]		
1714	Fill	1713	0.66	0.06	Primary Fill. Mid-brownish grey, friable sandy gravel. Same as (1710).		
1715	Fill	1713	0.7	0.12	Secondary Fill. Light grey, soft, silty sand. Same as (1711).		
1716	Fill	1713	0.7	0.28	Secondary Fill. Light greyish brown, soft, silty sand. Same as (1712).		
1717	Cut		0.26	0.24	Pit. Heavily truncated by [1713] ditch.		
1718	Fill	1717	0.26	0.24	Deliberate Backfill. Dark brown, friable, silty, gravelly sand.		
1719	Cut		0.4	0.08	Pit. Uncertain relation with [1717] and [1721].		
1720	Fill	1719	0.4	0.08	Deliberate Backfill. Dark brown, friable, sandy gravel.		
1721	Cut		0.54	0.08	Pit. Uncertain relation with [1719].		
1722	Fill	1721	0.08	0.54	Deliberate Backfill. Mid-brown, friable, sandy gravel.		
1723	Unexcavated feature		0.7		Other Cut. Fill is a mid grey brown, silty gravelly sand. Type of cut unknown.		

1724	Unexcavated feature		0.8	Pit. Fill is a dark brown, friable, sandy gravel. Possible pit.
1725	Unexcavated feature		0.4	Other Cut. Fill is a dark brown, soft, gravely, silty sand. Type of cut is not identified.

Trench 18							
General description					Orientation		E-W
Trench revealed one ditch. Consists of ploughsoil and subsoil overlying natural geology of sandy gravels.					Length (m)		30
					Width (m)		2
					Avg. depth (m)		0.47
Context No.	Type	Fill Of	Width (m)	Depth (m)	Description	Finds	Date
1800	Layer			0.25	Ploughsoil. Firm, dark greyish brown, silty clay		
1801	Layer				Natural. Loose, mid yellowish brown, sandy gravel		
1802	Cut		0.4	0.24	Ditch		
1803	Fill	1802	0.4	0.24	Primary Fill. Mid grey brown, silty sand		

Trench 19							
General description					Orientation		NW-SE
Trench devoid of archaeology. Consists of ploughsoil and subsoil overlying natural geology.					Length (m)		30
					Width (m)		2
					Avg. depth (m)		0.3
Context No.	Type	Fill Of	Width (m)	Depth (m)	Description	Finds	Date
1900	Layer			0.2	Ploughsoil. Dark grey brown, sandy silt		
1901	Layer			0.1	Subsoil. Mid orange brown, sandy silt		
1902	Layer				Natural. Mid brown orange, silty gravelly sand		

Trench 20							
General description					Orientation		NW-SE
Trench revealed one ditch at the southern end of the trench. Consists of ploughsoil and subsoil overlying natural gravels and sand.					Length (m)		30
					Width (m)		2
					Avg. depth (m)		0.65
Context No.	Type	Fill Of	Width (m)	Depth (m)	Description	Finds	Date
2000	Layer			0.3	Ploughsoil. Firm, dark greyish brown, silty clay		
2001	Layer			0.35	Subsoil. Soft, mid orange brown, sandy silt		
2002	Layer				Natural. Loose, Light yellowish brown, sandy gravel		
2003	Cut		0.78	0.42	Ditch		
2004	Fill	2003	0.78	0.42	Primary Fill. Dark grey brown, sandy silt.	Iron plate, plough share	C20
2005	Cut		1.5	0.26	Ring Gully. Possibly the same feature as [2007]		
2006	Fill	2005	1.5	0.26	Primary Fill. Mid orange brown, gravelly sandy silt		
2007	Cut		0.92	0.18	Ring Gully. Possibly the same feature as [2005]		
2008	Fill	2007	0.92	0.18	Primary Fill. Mid yellow brown, silty sand		

Trench 21							
General description					Orientation		N-S
Trench revealed 3 ditches. Consists of ploughsoil and subsoil overlying natural gravel and sand.					Length (m)		30
					Width (m)		2
					Avg. depth (m)		0.6
Context No.	Type	Fill Of	Width (m)	Depth (m)	Description	Finds	Date
2100	Layer			0.32	Ploughsoil. Mid brown grey sand silt		

2101	Layer			0.11	Subsoil. Mid yellow brown sand silt		
2102	Layer				Natural. Mid brown yellow sand and gravel		
2103	Cut		3.6	0.34	Ditch		
2104	Fill	2103	3.6	0.34	Primary Fill. Mid orangey brown	CBM	C16-C18
2105	Cut		1.8	0.58	Ditch		
2106	Fill	2105	1.8	0.58	Secondary Fill. Dark greyish black		
2107	Cut		2.01	0.2	Ditch		
2108	Fill	2107	2.01	0.2	Secondary Fill. Mid orangey brown		

Trench 22							
General description						Orientation	N-S
Trench revealed one ditch. Consisted of ploughsoil overlying natural geology of sand and gravel						Length (m)	30
						Width (m)	2
						Avg. depth (m)	0.3
Context No.	Type	Fill Of	Width (m)	Depth (m)	Description	Finds	Date
2200	Layer			0.3	Ploughsoil. Firm, dark greyish brown silty clay		
2201	Layer				Natural. Loose, light yellowish brown, sandy gravel		
2202	Cut		0.7	0.35	Ditch. E-W. Possible boundary or drainage ditch.		
2203	Fill	2202	0.7	0.35	Secondary Fill. Light reddish brown, clayey sand, soft. Moderate gravel, well sorted.		
2204	Cut		1.74	0.46	Ditch. Likely a natural feature such as a hedge row.		
2205	Fill	2204	1.74	0.46	Secondary Fill. Light greyish brown, silty sand, soft. Very infrequent gravel.		

Trench 23
-----------

General description					Orientation	NE-SW	
Trench devoid of archaeology. Consists of ploughsoil and subsoil overlying natural gravels and sand.					Length (m)	30	
					Width (m)	2	
					Avg. depth (m)	0.42	
Context No.	Type	Fill Of	Width (m)	Depth (m)	Description	Finds	Date
2300	Layer			0.33	Ploughsoil. Mid brown grey sand silt		
2301	Layer			0.1	Subsoil. Mid brown yellow sand silt		
2302	Layer				Natural. Mid brown yellow sand and gravel		

<b>Trench 24</b>							
General description					Orientation	E-W	
Trench revealed one ditch. Consists of ploughsoil and subsoil overlying natural geology of sand and gravel.					Length (m)	30	
					Width (m)	2	
					Avg. depth (m)	0.47	
Context No.	Type	Fill Of	Width (m)	Depth (m)	Description	Finds	Date
2400	Layer			0.3	Ploughsoil. Dark grey brown, sandy silt		
2401	Layer			0.17	Subsoil. Mid orange brown, sandy silt		
2402	Layer				Natural. Mid brown orange, silty gravelly sand		
2403	Cut		1.53	0.23	Ditch. Linear		
2404	Fill	2403			Primary Fill. Dark greyish brown sandy silt, no finds		
2405	Fill	2403			Secondary Fill. Dark greyish brown silt, 1 frag pot	Pot	RO
2406	Cut		0.65	0.36	Pit. Extends under L. O. E		
2407	Fill	2406			Primary Fill. Mid orangey greyish brown sandy silt, no finds		
2408	Fill	2406			Secondary Fill. Mid orangey greyish brown silt, no finds		

Trench 25							
General description					Orientation		NW-SE
Trench revealed one tree throw towards South end of trench. Consisted of ploughsoil and subsoil overlying natural geology of sand and gravel					Length (m)		30
					Width (m)		2
					Avg. depth (m)		0.55
Context No.	Type	Fill Of	Width (m)	Depth (m)	Description	Finds	Date
2500	Layer			0.3	Ploughsoil. Firm, dark greyish brown, silty clay		
2501	Layer			0.35	Subsoil. Soft, Mid orange brown, sandy silt		
2502	Layer				Natural. Loose, mid orange brown, sandy gravel		
2503	Cut		3.8	0.32	Tree Throw		
2504	Fill	2503			Other Fill. Light grey brown firm sand		
2505	Fill	2503			Other Fill. Charcoal rich clayey sand, fill of TT 2503	Flint, CPR	
2506	Layer			0.27	Natural. Firm light grey sand		

Trench 26							
General description					Orientation		E-W
Trench revealed one north-south aligned ditch and two pits. Consisted of ploughsoil and subsoil overlying natural geology of sand and gravel.					Length (m)		30
					Width (m)		2
					Avg. depth (m)		0.6
Context No.	Type	Fill Of	Width (m)	Depth (m)	Description	Finds	Date
2600	Layer			0.3	Ploughsoil. Firm, dark greyish brown, silty clay		
2601	Layer			0.3	Subsoil. Soft, mid orange brown, sandy gravels		
2602	Layer				Natural. Loose, Light orange brown, sandy gravel		
2603	Unexcavated feature		0.9		Ditch. Cut of ditch, filled by grey brown clayey sand w/gravel. Un-		

					excavated as same ditch dug in multiple Tr		
2604	Cut		1.02	0.41	Pit. Cut of sub-circular pit with gentle sides and flat base		
2605	Fill	2604	1.02	0.41	Secondary Fill. Dark grey brown clayey sand w/gravel	Pot, Fc	AD1100-1250
2606	Cut		1.06	0.33	Pit. Circular pit with gentle sides to a flat base		
2607	Fill	2606	1.06	0.21	Secondary Fill. Dark grey brown clayey sand w/gravel	Pot	AD1140-1220
2608	Fill	2606	0.51	0.12	Primary Fill. Mid grey brown gravel with silty sand, loose		

Trench 27							
General description					Orientation		E-W
Trench revealed 4 ditches, posthole and tree-throw. Consists of ploughsoil and subsoil overlying natural geology of sandy gravel.					Length (m)		30
					Width (m)		2.2
					Avg. depth (m)		0.4
Context No.	Type	Fill Of	Width (m)	Depth (m)	Description	Finds	Date
2700	Layer		2.2	0.3	Ploughsoil. Dark grey, compact gravelly sand		
2701	Layer		2.2	0.1	Subsoil. Mid greyish brown, gravelly silty sand.		
2702	Layer		2.2		Natural. Light brown sandy gravel		
2703	Cut		1.06	0.46	Ditch		
2704	Fill	2703	1.06	0.4	Secondary Fill. Soft, mid grey silty sand		
2705	Fill	2703	0.96	0.28	Secondary Fill. Soft, mid greyish brown silty sand.		
2706	Cut		0.4	0.1	Posthole		
2707	Fill	2706	0.4	0.1	Secondary Fill. Soft, mid brownish grey silty sand.		
2708	Cut		1.32	0.52	Ditch		



2709	Fill	2708	1.06	0.2	Primary Fill. Loose, light brownish grey silty sand.		
2710	Fill	2708	1.26	0.33	Secondary Fill. Soft, light grey sandy silt.		
2711	Fill	2708	0.9	0.1	Secondary Fill. Soft, light brownish grey sandy silt.		
2712	Cut		0.6	0.2	Ditch		
2713	Fill	2712	0.52	0.1	Secondary Fill. Soft, mid brownish grey sandy silt.		
2714	Fill	2712	0.6	0.1	Secondary Fill. Soft, mid greyish brown sandy silt.		
2715	Cut		1.2	0.3	Natural Feature. Treethrow		
2716	Fill	2715	1.2	0.3	Primary Fill. Loose, mid brown sandy silt.		
2717	Cut		1.42	0.32	Ditch		
2718	Fill	2717	0.44	0.08	Primary Fill. Loose, mid greyish brown silty sand.		
2719	Fill	2717	1.42	0.3	Secondary Fill. Soft, mid brown silty sand.		

### Trench 28

General description						Orientation	N-S
Trench revealed one ditch. Consisted of ploughsoil and subsoil overlying natural geology of sand and gravel						Length (m)	30
						Width (m)	2
						Avg. depth (m)	0.45
Context No.	Type	Fill Of	Width (m)	Depth (m)	Description	Finds	Date
2800	Layer			0.3	Ploughsoil. Dark grey brown, sandy silt		
2801	Layer			0.15	Subsoil. Mid orange brown, sandy silt		
2802	Layer				Natural. Mid brown orange, silty sand with gravel patches		
2803	Cut		0.79	0.14	Ditch		
2804	Fill	2803	0.79	0.14	Secondary Fill. Mid orange brown, silty sand		
2805	Void						

Trench 29							
General description					Orientation		N-S
Trench revealed one pit. Consisted of ploughsoil and subsoil overlying natural geology of sand and gravel.					Length (m)		30
					Width (m)		2
					Avg. depth (m)		0.58
Context No.	Type	Fill Of	Width (m)	Depth (m)	Description	Finds	Date
2900	Layer			0.35	Ploughsoil. Dark grey brown, clayey silt	Flint	
2901	Layer			0.23	Subsoil. Mid orange brown, clayey silt		
2902	Layer				Natural. Mid brown orange, silty sand with gravel patches		
2903	Cut		0.61	0.25	Pit. Prob modern		
2904	Fill	2903			Deliberate Backfill. Looks modern	Flint	
2905	Cut		0.43	0.16	Tree Throw		
2906	Fill	2905	0.43	0.16	Primary Fill		

Trench 30							
General description					Orientation		E-W
Trench revealed one ditch. Consisted of ploughsoil and subsoil overlying natural geology of sand and gravel					Length (m)		30
					Width (m)		2
					Avg. depth (m)		0.42
Context No.	Type	Fill Of	Width (m)	Depth (m)	Description	Finds	Date
3000	Layer			0.22	Ploughsoil. Dark grey brown, clayey silt	Flint	
3001	Layer			0.2	Subsoil. Mid orange brown, sandy silt		
3002	Layer				Natural. Mid brown orange, silty sand with gravels		
3003	Cut		0.74	0.23	Ditch		
3004	Fill	3003		0.13	Primary Fill. Mid orangey brown, no finds		
3005	Fill	3003	0.54	0.1	Secondary Fill. No finds.		

Trench 31							
General description					Orientation		N-S
Trench devoid of archaeology. Consisted of ploughsoil and subsoil overlying the natural geology of sand and gravel.					Length (m)		30
					Width (m)		2
					Avg. depth (m)		0.36
Context No.	Type	Fill Of	Width (m)	Depth (m)	Description	Finds	Date
3100	Layer			0.32	Ploughsoil. Mid brown grey sand silt		
3101	Layer			0.16	Subsoil. Mid red brown sand silt		
3102	Layer				Natural. Mid brown yellow sand and gravel		
3103	Void						

Trench 32							
General description					Orientation		N-S
Trench devoid of archaeology. Consists of ploughsoil and subsoil overlying natural geology of sandy gravel.					Length (m)		30
					Width (m)		2
					Avg. depth (m)		0.38
Context No.	Type	Fill Of	Width (m)	Depth (m)	Description	Finds	Date
3200	Layer			0.22	Ploughsoil. Firm, dark greyish brown, silty clay		
3201	Layer			0.3	Subsoil. Soft, mid yellowish brown, sandy silt		
3202	Layer				Natural. Loose, mid orange brown, sandy gravel		

Trench 33							
General description					Orientation		NE-SW
Trench devoid of archaeology. Consisted of ploughsoil and subsoil overlying natural geology of sand and gravel.					Length (m)		30
					Width (m)		2
					Avg. depth (m)		0.46

Context No.	Type	Fill Of	Width (m)	Depth (m)	Description	Finds	Date
3300	Layer			0.34	Ploughsoil. Mid brown grey sand silt		
3301	Layer			0.12	Subsoil. Mid red brown silt sand		
3302	Layer				Natural. Mid brown yellow sand and gravel		

### Trench 34

General description					Orientation	NW-SE	
Trench contains one N-S ditch. Consists of ploughsoil and subsoil overlying natural geology of sand and gravel.					Length (m)	30	
					Width (m)	2	
					Avg. depth (m)	0.44	
Context No.	Type	Fill Of	Width (m)	Depth (m)	Description	Finds	Date
3400	Layer			0.27	Ploughsoil. Dark grey brown, sandy silt		
3401	Layer			0.17	Subsoil. Mid orange brown, sandy silt		
3402	Layer				Natural. Mid brown orange, silty gravelly sand		
3403	Cut		1.6	0.2	Ditch. Likely boundary or possible trackway.	Pot	LBA/EIA
3404	Fill	3403	1.6	0.2	Secondary Fill. Mid brownish grey, silty gravel, very loose. Very diffuse.		

### Trench 35

General description					Orientation	E-W	
Trench contains two linear features. Consists of ploughsoil and subsoil overlying natural geology of sand and gravels.					Length (m)	30	
					Width (m)	2	
					Avg. depth (m)	0.48	
Context No.	Type	Fill Of	Width (m)	Depth (m)	Description	Finds	Date
3500	Layer			0.28	Ploughsoil. Dark grey brown, sandy silt		

3501	Layer			0.2	Subsoil. Mid orange brown, sandy silt		
3502	Layer				Natural. Mid brown orange with patches of light orange yellow, silty gravelly sand		
3503	Cut		1.18	0.37	Ditch. Cut of ditch terminus		
3504	Fill	3503	1.18	0.24	Secondary Fill. Mid brown grey, clayey sand, Secondary fill of Ditch Terminus 3503		
3505	Cut		1.4	0.33	Ditch. Cut of boundary/enclosure ditch		
3506	Fill	3505	1.4	0.33	Secondary Fill. Mid grey silty sand, soft/friable, secondary fill of boundary ditch 3505		
3507	Cut		0.75	0.17	Other Cut. Cut of probable natural hollow		
3508	Fill	3507	0.75	0.17	Other Fill. Secondary fill of natural hollow 3507, mid grey brown, clayey sand, soft/friable		
3509	Fill	3503	1.4	0.13	Primary Fill. Mid red brown, loose sandy gravel, primary fill of Ditch Terminus 3503		

Trench 36							
General description						Orientation	NW-SE
One gully running N-S. Consisted of ploughsoil and subsoil overlying natural geology of sand and gravel.						Length (m)	30
						Width (m)	2
						Avg. depth (m)	0.43
Context No.	Type	Fill Of	Width (m)	Depth (m)	Description	Finds	Date
3600	Layer			0.29	Ploughsoil. Dark grey brown, clayey silt		
3601	Layer			0.14	Subsoil. Mid orange brown, clayey silt		
3602	Layer				Natural. Mid brown orange, silty sand		
3603	Cut		0.44	0.11	Ditch. Shallow gully		
3604	Fill	3603	0.44	0.11	Secondary Fill. Light brown grey sterile silty sand, firm,		

Freq. Manganese. V. similar fill to natural
---------------------------------------------

### Trench 37

General description					Orientation		E-W
Trench devoid of archaeology. Trench consists of ploughsoil and subsoil overlying natural geology of sand with gravels patches.					Length (m)		30
					Width (m)		2
					Avg. depth (m)		0.58
Context No.	Type	Fill Of	Width (m)	Depth (m)	Description	Finds	Date
3700	Layer			0.26	Ploughsoil. Dark grey brown, clayey silt, moderately compact		
3701	Layer			0.32	Subsoil. Mid orange brown, clayey silt, moderately compact		
3702	Layer				Natural. Mid brown orange, clayey sand with gravelly patches		

### Trench 38

General description					Orientation		E-W
Trench devoid of archaeology. Consisted of ploughsoil and subsoil overlying natural geology of sand and gravel.					Length (m)		30
					Width (m)		2
					Avg. depth (m)		0.6
Context No.	Type	Fill Of	Width (m)	Depth (m)	Description	Finds	Date
3800	Layer			0.28	Ploughsoil. Dark grey brown, clayey silt, moderately compact		
3801	Layer			0.32	Subsoil. Mid orange brown, clayey silt, moderately compact		
3802	Layer				Natural. Mid brown orange, clayey sand with gravelly patches		

Trench 39							
General description					Orientation		NE-SW
Trench devoid of archaeology. Consists of ploughsoil and subsoil overlying natural geology of clay with sand.					Length (m)		30
					Width (m)		2.2
					Avg. depth (m)		0.49
Context No.	Type	Fill Of	Width (m)	Depth (m)	Description	Finds	Date
3900	Layer		2.2	0.3	Ploughsoil. Dark brownish grey silty clay		
3901	Layer		2.2	0.12	Natural. Mid yellow clayey sand		

Trench 40							
General description					Orientation		E-W
Trench devoid of archaeology. Consists of ploughsoil and subsoil overlying natural sandy gravels.					Length (m)		30
					Width (m)		2
					Avg. depth (m)		0.65
Context No.	Type	Fill Of	Width (m)	Depth (m)	Description	Finds	Date
4000	Layer			0.25	Ploughsoil. Dark greyish brown silty clay		
4001	Layer			0.4	Subsoil. Mid orange brown, sandy silt		
4002	Layer				Natural. Mid orange brown, sandy gravel		
4003	Void						

Trench 41							
General description					Orientation		E-W
Trench revealed a single pit. Consisted of ploughsoil overlying natural geology of sand and gravel.					Length (m)		30
					Width (m)		2
					Avg. depth (m)		0.42
Context No.	Type	Fill Of	Width (m)	Depth (m)	Description	Finds	Date

4100	Layer			0.3	Ploughsoil. Mid brown grey sand silt		
4101	Layer			0.15	Subsoil. Mid yellowish-brown sandy clay	Pot	MBA-EIA
4102	Layer				Natural. Mid red brown sand and gravel		
4103	Cut		2.40	0.34	Plough Furrow		
4104	Fill				Primary Fill		
4105	Cut		1.30	0.22	Tree Throw		
4106	Fill	4105			Primary Fill		
4107	Cut		0.55	0.23	Pit		
4108	Fill	4107			Primary Fill	Pot	MBA
4109	Cut		1.05	0.11	Tree Throw		
4110	Fill	4109			Primary Fill		

Trench 42							
General description					Orientation		NW-SE
Trench devoid of archaeology. Consisted of ploughsoil and subsoil overlying natural geology of sand with gravel.					Length (m)		30
					Width (m)		2
					Avg. depth (m)		0.42
Context No.	Type	Fill Of	Width (m)	Depth (m)	Description	Finds	Date
4200	Layer			0.22	Ploughsoil. Dark grey brown, friable clay silt		
4201	Layer			0.12	Subsoil. Dark brown grey clayey silt, friable		
4202	Layer				Natural. Light orange brown friable clayey sand with patches of gravel		

Trench 43			
General description		Orientation	E-W
Trench devoid of archaeology. Consisted of ploughsoil and subsoil overlying natural geology of clayey sand.		Length (m)	30
		Width (m)	2
		Avg. depth (m)	0.4



Context No.	Type	Fill Of	Width (m)	Depth (m)	Description	Finds	Date
4300	Layer			0.31	Ploughsoil. Dark grey brown, friable clayey silt		
4301	Layer			0.18	Subsoil. Light grey brown, friable silty sand		
4302	Layer				Natural. Light orange red, clayey sand, friable		

#### Trench 44

General description					Orientation	N-S	
Trench revealed two pits. Consisted of ploughsoil and subsoil overlying natural geology of clayey sand.					Length (m)	30	
					Width (m)	2	
					Avg. depth (m)	0.5	
Context No.	Type	Fill Of	Width (m)	Depth (m)	Description	Finds	Date
4400	Layer				Ploughsoil. Dark grey brown clayey silt, friable		
4401	Layer				Subsoil. Mid grey brown friable silty sand		
4402	Layer				Natural. Mid orange red, friable clayey sand		
4403	Cut		0.26	0.22	Posthole		
4404	Fill	4403	0.26	0.22	Secondary Fill. Mid greyish brown, soft silty sand with charcoal flecks.		
4405	Cut		0.44	0.18	Pit		
4406	Fill	4405	0.44	0.18	Deliberate Backfill. Mid greyish brown and orange patchy, soft, silty sand.		
4407	Cut		0.4	0.06	Modern. Unexcavated, possible modern disturbance. It forms 2 parallel linears in appearance.		
4408	Fill	4407	0.4	0.06	Deliberate Backfill. Light brownish grey silty sand.		
4409	Cut		1.3	0.13	Natural Feature. Irregular in shape. Section excavated. No photographs or drawing.		

4410	Fill	4409	1.3	0.13	Secondary Fill. Mid brownish grey and light grey patchy, soft silty sand.	
------	------	------	-----	------	---------------------------------------------------------------------------	--

Trench 45								
General description						Orientation		E-W
Trench devoid of archaeology. Consisted of ploughsoil overlying natural geology of sandy clay.						Length (m)		30
						Width (m)		2.2
						Avg. depth (m)		0.38
Context No.	Type	Fill Of	Width (m)	Depth (m)	Description	Finds	Date	
4500	Layer		2.2	0.28	Ploughsoil. Mid brownish grey sandy clay with rounded pebbles			
4501	Layer		2.2	0.08	Natural. Light yellow sandy clay with			

Trench 46								
General description						Orientation		N-S
Trench revealed a single ditch towards South end of trench. Consisted of ploughsoil overlying natural geology of sand.						Length (m)		30
						Width (m)		2
						Avg. depth (m)		0.6
Context No.	Type	Fill Of	Width (m)	Depth (m)	Description	Finds	Date	
4600	Layer			0.25	Ploughsoil. Dark greyish brown silty clay			
4601	Layer			0.2	Subsoil. Mid greyish brown sandy silt			
4602	Layer				Natural. Mid orange brown gravely sand			
4603	Cut		0.89	0.23	Ditch			
4604	Fill	4603			Primary Fill			

Trench 47								
General description						Orientation		N-S
Trench revealed a single pit towards North end of trench. Consisted of ploughsoil overlying natural geology of sand.						Length (m)		30
						Width (m)		2

						Avg. depth (m)	0.87
Context No.	Type	Fill Of	Width (m)	Depth (m)	Description	Finds	Date
4700	Layer			0.35	Ploughsoil. Dark greyish brown silty clay		
4701	Layer			0.3	Subsoil. Mid orangey brown sandy silt		
4702	Layer				Natural. Light Orange brown gravely sandy silt		
4703	Cut		0.72	1	Pit. Prehistoric		
4704	Fill	4703	0.42	1	Primary Fill	Flint	
4705	Fill	4703	0.62	1	Placed Deposit. Heavy charcoal deposit	Pot, Fc, Flint	LNeo/EBA
4706	Fill	4703	0.6	0.83	Placed Deposit	Pot, Flint	LPREH?, RO
4707	Fill	4703	0.73	0.69	Secondary Fill		
4708	Fill	4703	0.57	0.9	Placed Deposit. Fired clay "lining"	Pot, Worked Stone, Fc, Flint	LNeo/EBA, LPREH

#### Trench 48

General description					Orientation	NE-SW	
Trench devoid of archaeology. Consisted of ploughsoil overlying natural geology of gravel with sand					Length (m)	30	
					Width (m)	2.2	
					Avg. depth (m)	0.4	
Context No.	Type	Fill Of	Width (m)	Depth (m)	Description	Finds	Date
4800	Layer		30	0.29	Ploughsoil. Dark grey silty sand with gravel		
4801	Layer		2.3	0.11	Natural. Mid orange coarse sand with gravel mostly rounded to subrounded		

#### Trench 49

General description		Orientation	N-S
		Length (m)	30

Trench devoid of archaeology. Consisted of ploughsoil overlaying natural geology of coarse sand with gravel.					Width (m)	2	
					Avg. depth (m)	0.4	
Context No.	Type	Fill Of	Width (m)	Depth (m)	Description	Finds	Date
4900	Layer			0.35	Ploughsoil. Dark grey brown, sandy silt w/gravel		
4901	Layer				Natural. Dark red brown coarse sand with gravel		

Trench 50							
General description					Orientation	E-W	
Trench contains one ditch and two tree-throws. Consisted of ploughsoil overlaying natural geology of coarse sand with gravel.					Length (m)	50	
					Width (m)	2.2	
					Avg. depth (m)	0.39	
Context No.	Type	Fill Of	Width (m)	Depth (m)	Description	Finds	Date
5000	Layer		2.2	0.29	Ploughsoil. Dark grey sandy silt with gravel fraction of gravel is mostly rounded to wellrounded		
5001	Layer				Natural. Mid orange gravel with sand. Gravel is mid sorted mostly rounded to wellrounded		
5002	Cut		1.12	0.52	Tree Throw. Tree Throw, filled with single sterile sand fill		
5003	Fill		1.12	0.52	Other Fill. Sterile sand fill with visible rooting. Not drawn or photographed.		
5004	Cut		0.86	0.18	Ditch. Boundary/enclosure ditch. Modern looking fill		
5005	Fill	5004	0.86	0.18	Tertiary Fill. Dark almost black fill, possibly modern.		
5006	Cut		0.53	0.22	Tree Throw. Irregular oval Tree Throw, filled by single natural looking fill.		
5007	Fill		0.53	0.22	Secondary Fill. Mid red brown silty sand, loose, cut by ditch		

Trench 51
-----------

General description						Orientation	E--W
Trench revealed one pit and one ditch terminus. Consisted of ploughsoil and subsoil overlying natural geology of silty sand.						Length (m)	30
						Width (m)	2
						Avg. depth (m)	0.5
Context No.	Type	Fill Of	Width (m)	Depth (m)	Description	Finds	Date
5100	Layer				Ploughsoil. Mid grey brown silty sand	Flint	
5101	Layer				Subsoil. Mid orange brown silty sand		
5102	Layer				Natural. Mid orange brown silty sand		
5103	Cut		1.01	0.54	Ditch		
5104	Fill	5103	1.01	0.54	Deliberate Backfill		
5105	Cut		1.12	0.36	Pit		
5106	Fill	5105	1.12	0.36	Deliberate Backfill		

<b>Trench 52</b>							
General description						Orientation	N-S
Trench revealed one unexcavated natural feature and two excavated gullies. Consisted of ploughsoil overlying natural geology of silty sand with silt patches.						Length (m)	30
						Width (m)	2
						Avg. depth (m)	0.4
Context No.	Type	Fill Of	Width (m)	Depth (m)	Description	Finds	Date
5200	Layer				Ploughsoil. Dark blackish brown silt		
5201	Layer				Natural. Mid orangey brown silty sand, silt patches		
5202	Unexcavated feature		1.42		Natural Feature. Rooting		
5203	Cut		0.27	0.18	Ditch. Gully		
5204	Fill	5203		0.18	Primary Fill		
5205	Cut		0.25	0.15	Ditch. Gully		
5206	Fill	5205		0.15	Primary Fill		

<b>Trench 53</b>
------------------

General description						Orientation	E-W
Trench revealed a modern feature. Consisted of ploughsoil and subsoil overlaying natural geology of coarse sand with gravel.						Length (m)	30
						Width (m)	2.2
						Avg. depth (m)	0.5
Context No.	Type	Fill Of	Width (m)	Depth (m)	Description	Finds	Date
5300	Layer		2.2	0.35	Ploughsoil. Dark grey brown, sandy silt w/gravel		
5301	Layer		2.2	0.15	Subsoil. Dark red brown, silty sand w/gravel		
5302	Layer				Natural. Dark red brown coarse sand with gravel		
5303	Cut		2.98	0.5	Modern		
5304	Fill	5303	1.8	0.1	Deliberate Backfill. Compact, light yellowish-brown clayey sand		
5305	Fill	5303	2.84	0.48	Deliberate Backfill. Firm, dark grey sandy silt		

#### Trench 54

General description						Orientation	E-W
Trench revealed a modern feature. Consisted of ploughsoil and subsoil overlaying natural geology of coarse sand with gravel.						Length (m)	30
						Width (m)	2.2
						Avg. depth (m)	0.6
Context No.	Type	Fill Of	Width (m)	Depth (m)	Description	Finds	Date
5400	Layer		2.2	0.33	Ploughsoil. Mid grey silty clay with well-rounded gravel		
5401	Layer		2.2	0.11	Subsoil. Dark grey sandy silt with small fraction of gravel mostly well rounded		
5402	Layer		2.2	0.34	Natural. Dark brown to black coarse sand with gravel mostly well rounded		

5403	Cut		2.86	0.52	Modern		
5404	Fill	5403	2.86	0.52	Deliberate Backfill. Loose, dark grey silty sand.	Iron sheet, nail, Bu Flint	Modern

Trench 55							
General description						Orientation	NW-SE
Trench revealed a tree throw and modern disturbance to the SE end of the trench. Consisted of ploughsoil and subsoil overlaying natural geology of sand with gravel.						Length (m)	30
						Width (m)	2
						Avg. depth (m)	0.6
Context No.	Type	Fill Of	Width (m)	Depth (m)	Description	Finds	Date
5500	Layer			0.35	Ploughsoil. Dark greyish brown, silty clay		
5501	Layer			0.2	Subsoil. Mid greyish brown, sandy gravel silt		
5502	Layer				Natural. Light yellowish-brown sandy gravel		
5503	Cut		1.5	0.36	Tree Throw		
5504	Fill	5503	1.5	0.36	Secondary Fill. Mid greyish brown, soft/friable silty, gravely sand.		
5505	Cut				Modern. Slot has been dug, not recorded.		

Trench 56		
General description	Orientation	NE-SW

Trench revealed a single gully. Consisted of ploughsoil overlying natural geology of gravels.						Length (m)	30
						Width (m)	2
						Avg. depth (m)	0.55
Context No.	Type	Fill Of	Width (m)	Depth (m)	Description	Finds	Date
5600	Layer			0.3	Ploughsoil. Dark blackish brown silt		
5601	Layer			0.25	Subsoil. Mid orange brown sandy gravel		
5602	Layer				Natural. Dark and light patches of orange and brown gravel		
5603	Cut		0.35	0.15	Other Cut. Gully		
5604	Fill	5603	0.35	0.15	Primary Fill		

<b>Trench 57</b>													
General description						Orientation	NW-SE						
						Trench devoid of archaeology. Consisted of ploughsoil and subsoil overlying natural geology of sand with gravel.						Length (m)	30
												Width (m)	2.2
Avg. depth (m)	0.45												
Context No.	Type	Fill Of	Width (m)	Depth (m)	Description	Finds	Date						
5700	Layer		2.2	0.32	Ploughsoil. Dark grey clay with sand with rounded to well rounded gravel								
5701	Layer		2.2	0.08	Subsoil. Dark brownish grey sandy clay with gravel mostly well rounded								
5702	Layer				Natural. Mid orange coarse sand with gravel								



Trench 58							
General description					Orientation		NE-SW
Trench contains area of modern disturbance towards south end. Disturbance tested in two areas. Ploughsoil and subsoil overlying natural geology of coarse sandy gravels.					Length (m)		30
					Width (m)		2
					Avg. depth (m)		0.55
Context No.	Type	Fill Of	Width (m)	Depth (m)	Description	Finds	Date
5800	Layer			0.30	Ploughsoil. Dark grey sandy silt with gravel fraction of gravel is mostly rounded to well rounded		
5801	Layer			0.14	Subsoil. Mixed red brown sandy gravel, loose		
5802	Layer				Natural. Mid orange gravel with sand. Gravel is mid sorted mostly rounded to well rounded		
5803	Cut				Modern. Representing modern levelling layer over the base of the length of tr58, modern features cut into this. 2 sondages hand dug.		

Trench 59							
General description					Orientation		E-W
Trench revealed post-med. disturbance throughout the whole trench. Consists of ploughsoil and subsoil overlying natural geology of gravel and sand.					Length (m)		30
					Width (m)		2
					Avg. depth (m)		0.66
Context No.	Type	Fill Of	Width (m)	Depth (m)	Description	Finds	Date

5900	Layer			0.3	Ploughsoil. Dark greyish brown, silty clay		
5901	Layer			0.36	Subsoil. Mid greyish brown, sandy silt		
5902	Layer				Natural. Light yellowish brown, sandy gravel		
5903	Cut		1	0.3	Modern. 1x1m slot dug in potential ditch but was revealed to be not real and in fact were layers of made ground. Possibly levelled out with dumps of redeposited natural gravel and sand.		
5904	Fill	5903		0.3	Deliberate Backfill. Fill of test pit 1x1m. Mid to light greyish brown and yellowish-brown sandy gravels with occasional brick inclusions. Believed to be layers of made ground. Possibly levelled out with dumps of redeposited natural gravel and sand.		

Trench 60							
General description					Orientation	NE-SW	
Trench revealed a large post-medieval dump at the SW end of the trench. Consisted of ploughsoil overlying natural geology of gravel and sand.					Length (m)	0.3	
					Width (m)	2	
					Avg. depth (m)	0.8	
Context No.	Type	Fill Of	Width (m)	Depth (m)	Description	Finds	Date

6000	Layer			0.3	Ploughsoil. Dark blackish brown silt		
6001	Layer			0.25	Subsoil. Mid yellowish grey brown sandy silt		
6002	Layer				Natural. Light yellowish brown gravelly sand		

Trench 61							
General description					Orientation		E-W
Trench revealed one modern feature. Trench consists of ploughsoil and subsoil overlying first of several colluvial layers. Natural geology was not exposed in trench.					Length (m)		30
					Width (m)		2
					Avg. depth (m)		0.64
Context No.	Type	Fill Of	Width (m)	Depth (m)	Description	Finds	Date
6100	Layer			0.28	Ploughsoil. Dark grey brown, silty sand	Flint	
6101	Layer			0.24	Subsoil. Dark orange brown, silty sand		
6102	Layer			0.16	Colluvial Layer. Light grey brown, silty sand	Pot	LBA/IA
6103	Layer			0.12	Colluvial Layer. Mid brown grey, silty sand	Flint	
6104	Layer			0.12	Colluvial Layer. Light orange grey, silty sand	Flint	
6105	Layer				Colluvial Layer. Mid orange grey, silty sand. Not fully excavated		
6106	Cut		1.4	0.4	Modern. Backfilled evaluation trench		
6107	Fill	6106	1.4	0.4	Deliberate Backfill. A mixture of redeposited subsoil (6101) and colluvial material (6102).		

6108	Layer				Colluvial Layer. Light brown grey, silty sand	
------	-------	--	--	--	-----------------------------------------------	--

Trench 62							
General description					Orientation		N-S
Trench devoid of archaeology. Consists of ploughsoil, overlying four colluvial layers. Natural geology only exposed at S end of trench consisting silty sand with gravel.					Length (m)		30
					Width (m)		2
					Avg. depth (m)		1
Context No.	Type	Fill Of	Width (m)	Depth (m)	Description	Finds	Date
6200	Layer			0.21	Ploughsoil. Dark grey brown, silty sand	Flint	
6201	Void						
6202	Layer			0.53	Colluvial Layer. Mid brown grey, silty sand		

Trench 63							
General description					Orientation		NW-SE
Trench devoid of archaeology. Consisted of ploughsoil and subsoil overlying natural geology of sandy silt.					Length (m)		30
					Width (m)		2
					Avg. depth (m)		0.69
Context No.	Type	Fill Of	Width (m)	Depth (m)	Description	Finds	Date
6300	Layer			0.27	Ploughsoil. Dark greyish brown, sandy silt, friable		
6301	Layer			0.5	Subsoil. Mid orange brown, sandy silt, friable		
6302	Layer				Natural. Mid orange brown, sandy silt.		

6303	Void					
------	------	--	--	--	--	--

Trench 64							
General description						Orientation	N-S
Trench revealed one NE-SW aligned gully and colluvial layers to the northern end of the trench. Consisted of ploughsoil, subsoil and colluvial layers overlying natural geology of silty sand.						Length (m)	30
						Width (m)	2
						Avg. depth (m)	0.74
Context No.	Type	Fill Of	Width (m)	Depth (m)	Description	Finds	Date
6400	Layer		2	0.36	Ploughsoil. Dark brownish grey silty sand.		
6401	Layer		2	0.4	Subsoil. Mid-brown silty sand.		
6402	Fill	6404	0.9	0.14	Secondary Fill. Mid grey brown, silty sand		
6403	Fill	6404	0.68	0.2	Secondary Fill. Mid brown grey, silty sand.		
6404	Cut		0.9	0.32	Ditch		
6405	Layer			0.36	Colluvial Layer. Mid yellowish-grey, compact, silty sand. Contained pottery.	Pot, Flint	LBA/IA, LMeso
6406	Layer			0.24	Colluvial Layer. Mid brown grey, sandy silt.	Pot	LBA/IA
6407	Layer			0.29	Colluvial Layer. Light yellow grey, silty sand.	Pot	RO
6408	Layer				Natural. Mid orange brown silty sand.		

Trench 65							
General description						Orientation	N-S
Trench devoid of archaeology. Consisted of ploughsoil and subsoil overlying natural geology of sandy silt.						Length (m)	30
						Width (m)	2

						Avg. depth (m)	0.7
Context No.	Type	Fill Of	Width (m)	Depth (m)	Description	Finds	Date
6500	Layer			0.24	Ploughsoil. Dark greyish brown, sandy silt, friable		
6501	Layer			0.4	Subsoil. Mid orange brown, sandy silt, friable		
6502	Layer				Natural. Mid orange brown, sandy silt, friable		

<b>Trench 66</b>							
General description					Orientation	N-S	
Trench devoid of archaeology. Consisted of ploughsoil, subsoil and colluvium overlying the natural geology					Length (m)	30	
					Width (m)	2	
					Avg. depth (m)	0.73	
Context No.	Type	Fill Of	Width (m)	Depth (m)	Description	Finds	Date
6600	Layer		2	0.3	Ploughsoil. Mid brown grey, silty sand.	Flint	
6601	Layer		2	0.43	Subsoil. Mid orange brown, silty sand.		
6602	Layer		2	0.45	Colluvial Layer. Light grey brown sandy silt. Not fully excavated.		
6603	Layer				Natural. Mid orange brown silty sand with gravel patches		

<b>Trench 67</b>			
General description		Orientation	N-S
		Length (m)	30

Trench devoid of archaeology. Consisted of ploughsoil and subsoil overlying natural geology silty sand.						Width (m)	2
						Avg. depth (m)	0.75
Context No.	Type	Fill Of	Width (m)	Depth (m)	Description	Finds	Date
6700	Layer			0.3	Ploughsoil. Dark greyish brown, sandy silt, friable		
6701	Layer			0.5	Subsoil. Mid orange brown, sandy silt, friable		
6702	Layer				Natural. Mid orange brown, silty sand		

Trench 68							
General description						Orientation	NE-SW
						Trench revealed Colluvial layers to NE end of trench. Consisted of ploughsoil, subsoil and colluvium overlying the natural geology of sandy silt.	
Width (m)	2.2						
Avg. depth (m)	0.73						
Context No.	Type	Fill Of	Width (m)	Depth (m)	Description	Finds	Date
6800	Layer			0.33	Ploughsoil. Dark grey brown, sandy silt.		
6801	Layer			0.31	Subsoil. Mid grey brown, sandy silt.		
6802	Layer				Natural. Mid orange brown, sandy silt.		
6803	Layer			0.3	Colluvial Layer. Light grey brown, sandy silt.		
6804	Layer			0.25	Colluvial Layer. Mid grey brown, sandy silt.	Pot, Flint, Bu Flint	LBA/IA
6805	Layer			0.25	Colluvial Layer. Light grey brown, sandy silt.		

Trench 69							
General description					Orientation		N-S
Trench revealed one pit. Consists of ploughsoil and subsoil overlying natural geology of clayey sand.					Length (m)		30
					Width (m)		2
					Avg. depth (m)		0.68
Context No.	Type	Fill Of	Width (m)	Depth (m)	Description	Finds	Date
6900	Layer			0.32	Ploughsoil. Dark grey brown, clayey sand		
6901	Layer			0.36	Subsoil. Mid orange brown, silty sand		
6902	Layer				Natural. Mid brown orange, clayey sand		
6903	Cut		0.84	0.3	Pit		
6904	Fill	6903	0.84	0.3	Secondary Fill. Mid orange brown, clayey silt	Pot	LBA/IA

Trench 70							
General description					Orientation		N-S
Trench devoid of archaeology. Consisted of ploughsoil and subsoil overlying colluvial layers.					Length (m)		30
					Width (m)		2
					Avg. depth (m)		1
Context No.	Type	Fill Of	Width (m)	Depth (m)	Description	Finds	Date
7000	Layer			0.26	Ploughsoil. Mid grey brown, clayey silt	Flint	
7001	Layer			0.18	Subsoil. Mid brown orange, sandy silt		
7002	Layer			0.16	Colluvial Layer. Mid orange brown, clayey silt		



7003	Void					
7004	Void					
7005	Void					
7006	Void					
7007	Layer			0.14	Colluvial Layer. Light blue grey, silty sand	
7008	Void					
7009	Layer			0.18	Colluvial Layer. Mid brown orange, silty sand	

Trench 71							
General description					Orientation		N-S
Trench revealed a tree throw. Consisted of ploughsoil overlying natural geology of sand					Length (m)		30
					Width (m)		2
					Avg. depth (m)		0.5
Context No.	Type	Fill Of	Width (m)	Depth (m)	Description	Finds	Date
7100	Layer			0.37	Ploughsoil. Mid grey brown, silty sand.		
7101	Layer				Natural. Light orange brown, silty sand.		
7102	Cut		1.39	0.12	Tree Throw		
7103	Fill	7102	1.39	0.12	Secondary Fill. Mid orange brown, silty sand		

Trench 72			
General description		Orientation	NE-SW
		Length (m)	30
		Width (m)	2

Trench devoid of archaeology. Consists of a ploughsoil overlying colluvial at the SW end of the trench and natural geology of silty sand.					Avg. depth (m)		0.34
Context No.	Type	Fill Of	Width (m)	Depth (m)	Description	Finds	Date
7200	Layer			0.34	Ploughsoil. Dark grey brown, silty clay		
7201	Layer				Natural. Mid brown orange, silty sand		
7202	Layer		4.68	0.22	Colluvial Layer. Mid grey brown, frequent manganese inclusion		

<b>Trench 73</b>							
General description					Orientation		E-W
Trench devoid of archaeology. Consisted of ploughsoil and subsoil overlying natural geology of silty sand with gravel patches.					Length (m)		30
					Width (m)		2
					Avg. depth (m)		0.6
Context No.	Type	Fill Of	Width (m)	Depth (m)	Description	Finds	Date
7300	Layer			0.35	Ploughsoil. Mid brownish grey, moderately compact silty sand with natural flints and pebbles.		
7301	Layer			0.3	Subsoil. Mid brown, soft silty sand with natural flints and pebbles.		
7302	Layer				Natural. Mid orange brown, soft silty sand with patches of gravel.		

Trench 74							
General description					Orientation		E-W
Trench revealed a single tree throw. Consists of ploughsoil and subsoil overlying natural geology of sandy silt with gravels.					Length (m)		30
					Width (m)		2
					Avg. depth (m)		0.62
Context No.	Type	Fill Of	Width (m)	Depth (m)	Description	Finds	Date
7400	Layer			0.57	Ploughsoil. Dark grey brown, sandy silt.		
7401	Layer			0.28	Subsoil. Mid orange brown, sandy silt.		
7402	Layer				Natural. Mid orange brown, sandy silt with gravel patches		
7403	Cut		1.2	0.17	Tree Throw		
7404	Fill	7403	1.2	0.17	Secondary Fill. Mid grey brown, sandy silt.		

Trench 75							
General description					Orientation		N-S
Trench devoid of archaeology. Consisted of ploughsoil and subsoil overlying natural geology of sandy silt with gravels.					Length (m)		30
					Width (m)		2
					Avg. depth (m)		0.43
Context No.	Type	Fill Of	Width (m)	Depth (m)	Description	Finds	Date
7500	Layer			0.34	Ploughsoil. Dark grey brown, sandy silt, friable		
7501	Layer			0.3	Subsoil. Mid orange brown, sandy silt, friable		

7502	Layer				Natural. Mid orange brown, sandy silt with frequent gravel, friable	
------	-------	--	--	--	---------------------------------------------------------------------	--

Trench 76							
General description					Orientation	NE-SW	
Trench revealed one pit, a NE-SW aligned ditch and a natural feature. Consisted of ploughsoil and subsoil overlying natural geology of silty sand with gravels.					Length (m)	30	
					Width (m)	2	
					Avg. depth (m)	0.56	
Context No.	Type	Fill Of	Width (m)	Depth (m)	Description	Finds	Date
7600	Layer			0.42	Ploughsoil. Mid brown grey, silty sand		
7601	Layer			0.12	Subsoil. Light brown yellow, silty sand		
7602	Layer				Natural. Mid brown yellow, silty sand with gravel		
7603	Cut		0.49	0.28	Pit		
7604	Fill	7603		0.28	Secondary Fill. Mid grey brown, sandy silt		
7605	Cut		0.8	0.28	Ditch		
7606	Fill	7605		0.28	Secondary Fill. Mid brown grey, sandy silt		
7607	Cut		1.2	0.36	Natural Feature		
7608	Fill	7607	1.2	0.36	Secondary Fill. Light brown grey, sandy silt		

Trench 77			
General description		Orientation	N-S
Trench revealed 4 pits and two tree throws. Consisted of ploughsoil and subsoil overlying natural geology of sandy gravel.		Length (m)	22.5
		Width (m)	22.7

						Avg. depth (m)	0.55
Context No.	Type	Fill Of	Width (m)	Depth (m)	Description	Finds	Date
7700	Layer			0.4	Ploughsoil. Dark grey brown, silty clay.		
7701	Layer			0.2	Subsoil. Mid yellow brown, sandy clay.		
7702	Layer				Natural. Light yellow brown, silty sand.		
7703	Cut		1.8	0.17	Tree Throw		
7704	Fill	7703	1.8	0.17	Primary Fill. Light grey brown, sandy silt.		
7705	Cut		1.15	0.22	Tree Throw		
7706	Fill	7705	1.15	0.22	Primary Fill. Light grey brown, silty sand		
7707	Cut		0.5	0.1	Pit		
7708	Fill	7707	0.5	0.1	Primary Fill. Mid grey brown, sandy silt.		
7709	Cut		0.5	0.14	Pit		
7710	Fill	7709	0.5	0.14	Primary Fill. Mid grey brown, sandy clay		
7711	Cut		0.75	0.16	Pit		
7712	Fill	7711	0.75	0.16	Primary Fill. Mid grey brown, sandy silt		
7713	Cut		0.78	0.28	Pit		
7714	Fill	7713	0.78	0.28	Primary Fill. Mid grey brown, sandy silt		

<b>Trench 78</b>		
General description	Orientation	NW-SE
Trench contains 1 tree throw and 1 ditch terminus. Consisted of ploughsoil and subsoil overlying natural geology of silty sand.	Length (m)	30
	Width (m)	2

						Avg. depth (m)	0.37
Context No.	Type	Fill Of	Width (m)	Depth (m)	Description	Finds	Date
7800	Layer			0.24	Ploughsoil. Dark grey brown, sandy silt		
7801	Layer			0.13	Subsoil. Mid brown orange, silty sand		
7802	Layer				Natural. Mid orange brown, silty sand		
7803	Cut		0.96	0.2	Ditch. Terminus		
7804	Fill	7803	0.96	0.2	Secondary Fill. Mid orange brown, sandy silt		
7805	Cut		0.52	0.19	Tree Throw		
7806	Fill	7805	0.52	0.19	Other Fill. Mid brown grey, sandy silt		

<b>Trench 79</b>							
General description					Orientation		NE-SW
Trench revealed two ditches and a tree throw. Consisted of ploughsoil and subsoil overlying natural geology of sand					Length (m)		30
					Width (m)		2
					Avg. depth (m)		0.36
Context No.	Type	Fill Of	Width (m)	Depth (m)	Description	Finds	Date
7900	Layer			0.27	Ploughsoil. Dark grey brown, clayey sand.		
7901	Layer			0.12	Subsoil. Mid orange brown, clayey sand.		
7902	Layer				Natural. Mid brown orange, silty sand with gravel patches.		
7903	Cut		2.3	0.24	Tree Throw		

7904	Fill	7903	2.3	0.24	Secondary Fill. Mid brown grey, sandy silt.		
7905	Cut		1.48	0.34	Ditch		
7906	Fill	7905	1.48	0.34	Secondary Fill. Mid brown grey, clayey sand.		
7907	Cut		0.97	0.14	Ditch		
7908	Fill	7907	0.97	0.14	Secondary Fill. Mid grey brown, clayey sand, moderately compact		

Trench 80							
General description					Orientation	NE-SW	
Trench contains two ditches. Consists of ploughsoil and subsoil layers overlaying the natural geology of silty sand with gravel patches.					Length (m)	30	
					Width (m)	2	
					Avg. depth (m)	0.39	
Context No.	Type	Fill Of	Width (m)	Depth (m)	Description	Finds	Date
8000	Layer			0.3	Ploughsoil. Dark grey brown, silty sand		
8001	Layer			0.32	Subsoil. Mid orange brown, silty sand		
8002	Layer				Natural. Mid brown orange, silty sand with gravel patches		
8003	Cut		1.64	0.26	Ditch		
8004	Fill	8003	1.64	0.26	Primary Fill. Mid brown grey, clayey sand		
8005	Cut		1.94	0.18	Ditch		
8006	Fill	8005	1.94	0.18	Secondary Fill. Light grey brown, sandy silt.		

Trench 81							
General description					Orientation		N-S
Trench devoid of archaeology. Consisted of ploughsoil and subsoil overlying the natural geology of silty sand with gravel.					Length (m)		30
					Width (m)		2
					Avg. depth (m)		0.55
Context No.	Type	Fill Of	Width (m)	Depth (m)	Description	Finds	Date
8100	Layer		2	0.3	Ploughsoil. Dark greyish brown, soft silty sand with nat. flints and pebbles.		
8101	Layer		30	0.15	Subsoil. Mid brown, soft silty sand with nat. flints and pebbles.		
8102	Layer		30		Natural. Mid orange brown, soft silty sand with patches of gravel.		

Trench 82							
General description					Orientation		E-W
Trench devoid of archaeology. Consisted of ploughsoil and subsoil overlying natural geology of silty clayey sand.					Length (m)		30
					Width (m)		2
					Avg. depth (m)		0.45
Context No.	Type	Fill Of	Width (m)	Depth (m)	Description	Finds	Date
8200	Layer			0.3	Ploughsoil. Compact, mid-greyish brown silty clay with natural flints and pebbles.		
8201	Layer			0.15	Subsoil. Soft, mid-orange brown silty, clayey sand with occasional natural flints and pebbles.		
8202	Layer				Natural. Soft, mid-brown, silty clayey		



					sand with moderate natural flints and pebbles.	
--	--	--	--	--	------------------------------------------------	--

### Trench 83

General description					Orientation	NE-SW	
Trench devoid of archaeology. Consists of a ploughsoil and subsoil overlaying the natural geology of silty sand with gravel.					Length (m)	15	
					Width (m)	2	
					Avg. depth (m)	0.65	
Context No.	Type	Fill Of	Width (m)	Depth (m)	Description	Finds	Date
8300	Layer			0.35	Ploughsoil. Dark grey brown, silty sand		
8301	Layer			0.12	Subsoil. Mid grey brown, silty sand		
8302	Layer				Natural. Mid brown orange, silty sand with gravel		

### Trench 84

General description					Orientation	NE-SW	
Trench revealed one ditch. Consisted of ploughsoil and subsoil overlying natural geology of silty sand with gravel.					Length (m)	30	
					Width (m)	2	
					Avg. depth (m)	0.48	
Context No.	Type	Fill Of	Width (m)	Depth (m)	Description	Finds	Date
8400	Layer			0.29	Ploughsoil. Mid grey brown, silt sand.		
8401	Cut		1.1	0.78	Ring Ditch		
8402	Fill	8401	0.42	0.24	Tertiary Fill. Light grey brown sandy clay.		

8403	Fill	8401	0.92	0.3	Tertiary Fill. Dark grey brown silty clay.		
8404	Fill	8401	0.36	0.12	Primary Fill. Dark grey black, silty clay.		
8405	Fill	8401	0.4	0.34	Primary Fill. Mid red brown, silty sand.		
8406	Layer				Natural. Mid brown orange, silty sand with gravel		

Trench 85							
General description					Orientation	NE-SW	
Trench revealed one ditch. Consisted of ploughsoil and subsoil overlying natural geology of silty sand with gravel.					Length (m)	30	
					Width (m)	2	
					Avg. depth (m)	0.27	
Context No.	Type	Fill Of	Width (m)	Depth (m)	Description	Finds	Date
8500	Layer			0.3	Ploughsoil. Dark greyish brown, sandy silt.		
8501	Layer			0.07	Subsoil. Mid orange brown, silty sand.		
8502	Layer				Natural. Mid yellowish brown, silty sand with gravel patches		
8503	Cut		0.9	0.37	Ditch		
8504	Fill	8503	0.9	0.37	Secondary Fill. Light grey brown, silty sand		

Trench 86		
General description	Orientation	NE-SW

Trench revealed two ditches and a tree throw. Consists of a ploughsoil overlying the natural geology of silty sand with gravel.						Length (m)	30
						Width (m)	2.1
						Avg. depth (m)	0.38
Context No.	Type	Fill Of	Width (m)	Depth (m)	Description	Finds	Date
8600	Layer			0.38	Ploughsoil. Dark grey brown, silty sand.		
8601	Layer				Natural. Mid brown orange, silty sand with gravel.		
8602	Cut		1	0.14	Ditch		
8603	Fill	8602	1	0.14	Secondary Fill. Dark brown grey, silty sand	CBM	PMED
8604	Cut		0.74	0.18	Ditch		
8605	Fill	8604	0.74	0.18	Secondary Fill. Mid grey brown, silty sand		
8606	Cut		0.55	0.12	Tree Throw		
8607	Fill	8606	0.55	0.12	Secondary Fill. Mid grey brown, silty sand		

<b>Trench 87</b>													
Trench revealed one ditch. Consisted of ploughsoil, subsoil and colluvial layer overlaying the natural geology of silty sand with gravels.						Orientation	E-W						
						Length (m)	30						
						Width (m)	2						
						Avg. depth (m)	0.6						
						Context No.	Type	Fill Of	Width (m)	Depth (m)	Description	Finds	Date
						8700	Layer			0.26	Ploughsoil. Dark grey brown, silty clay		
8701	Layer				Natural. Mid brown orange, friable silty coarse sand and variation of light grey,								

					friable coarse sandy gravel.		
8702	Layer			0.14	Subsoil. Orange-brown, firm/plastic sandy clay.		
8703	Cut		9.1	0.64	Ditch. Possible ditch.		
8704	Fill	8703	6.6	0.16	Secondary Fill. Light brownish grey, firm/plastic sandy clay.		
8705	Fill	8703	5.4	0.4	Secondary Fill. Mid-greyish brown, soft, silty, clayey sand with gravelly patches.		
8706	Fill	8703	7.4	0.3	Secondary Fill. Mid-brown, soft, silty, clayey sand.		
8707	Layer			0.26	Colluvial Layer. Mid-orange-brown, plastic/firm clayey sand with pebbles.		
8708	Layer			0.3	Colluvial Layer. Same as (8707)		

<b>Trench 88</b>							
General description					Orientation		N-S
Trench revealed five ditches. Consists of a ploughsoil and subsoil overlying the natural geology of sandy silt.					Length (m)		30
					Width (m)		2
					Avg. depth (m)		0.8
Context No.	Type	Fill Of	Width (m)	Depth (m)	Description	Finds	Date
8800	Layer				Ploughsoil. Mid brown silt		
8801	Layer				Subsoil. Mid brownish orange sandy silt		
8802	Layer				Natural. Mid brownish orange sandy silt		

8803	Cut		0.54	0.26	Ditch. Terminus		
8804	Fill	8803			Primary Fill. Sole fill, no finds		
8805	Cut		1.05	0.16	Ditch		
8806	Fill	8805			Primary Fill. Sole fill, no finds		
8807	Cut		1.50	0.45	Ditch		
8808	Fill	8807			Primary Fill. Mid brown silt. No finds		
8809	Fill	8807			Secondary Fill. Mid brown sandy silt. No finds		
8810	Cut		3.53	0.1	Ditch. Not bottomed		
8811	Fill	8810			Other Fill		
8812	Cut		0.41	0.25	Ditch		
8813	Fill	8812	0.41	0.25	Secondary Fill. Mid orange brown, clayey silt		

### Trench 89

General description					Orientation		
Not excavated. Trench located under low overhead power lines.					Length (m)		
					Width (m)		
					Avg. depth (m)		
Context No.	Type	Fill Of	Width (m)	Depth (m)	Description	Finds	Date

### Trench 90

General description		Orientation		E-W
Trench contains two ditches and a natural feature. Consists of ploughsoil and subsoil overlying natural geology of silty sand with gravels.		Length (m)		30
		Width (m)		2
		Avg. depth (m)		0.41

Context No.	Type	Fill Of	Width (m)	Depth (m)	Description	Finds	Date
9000	Layer			0.3	Ploughsoil. Mid grey brown, silt sand, friable		
9001	Layer			0.17	Subsoil. Mid orangish brown, silty sand.		
9002	Layer				Natural. Mid brownish orange, silty sand with gravel inclusions.		
9003	Void						
9004	Void						
9005	Cut		0.58	0.16	Ditch. Possible.		
9006	Fill	9005	0.58	0.16	Deliberate Backfill. Dark brownish grey, soft silty sand with pebbles.		
9007	Cut		0.3	0.28	Natural Feature. Possible natural depression filled by brown sand.		
9008	Fill	9007	0.3	0.28	Primary Fill. Light brown, soft sand with pebbles.		
9009	Cut		0.84	0.18	Ditch		
9010	Fill	9009	0.72	0.12	Secondary Fill. Dark brown, friable sandy gravel.		
9011	Fill	9009	0.84	0.06	Deliberate Backfill. Dark brownish grey, soft/friable silty sand with pebbles.		

<b>Trench 91</b>		
General description	Orientation	E-W
Trench revealed four ditches and one tree throw. Consists of ploughsoil overlying natural geology of silty sand with gravel.	Length (m)	30
	Width (m)	2

						Avg. depth (m)	0.4
Context No.	Type	Fill Of	Width (m)	Depth (m)	Description	Finds	Date
9100	Layer			0.42	Ploughsoil. Dark grey brown, silty sand		
9101	Layer				Natural. Mid brown orange, silty sand with gravel		
9102	Cut		0.96	0.16	Tree Throw		
9103	Fill	9102	0.96	0.16	Primary Fill. Mid greyish-brown, silty sand		
9104	Cut		0.94	0.3	Ditch		
9105	Fill	9104	0.94	0.3	Primary Fill. Light greyish brown, silty sand		
9106	Cut		0.9	0.2	Ditch		
9107	Fill	9106	0.9	0.2	Deliberate Backfill. Dark brownish grey, silty sand	Iron batten ring	C18
9108	Cut		0.58	0.14	Ditch		
9109	Fill	9108	0.58	0.14	Primary Fill. Light greyish brown, silty sand		
9110	Cut		0.84	0.16	Ditch		
9111	Fill	9110		0.16	Primary Fill. Mid greyish brown, silty sand		

<b>Trench 92</b>		
General description	Orientation	E-W
Trench devoid of archaeology. Consists of ploughsoil and subsoil overlying natural geology of silts with gravel.	Length (m)	30
	Width (m)	2
	Avg. depth (m)	0.6

Context No.	Type	Fill Of	Width (m)	Depth (m)	Description	Finds	Date
9200	Layer			0.3	Ploughsoil. Mid grey brown silt sand, friable		
9201	Layer			0.28	Subsoil. Mid orange brown, silt sand, friable		
9202	Layer				Natural. Mottled brownish orange, silt with gravel inclusions		

<b>Trench 93</b>							
General description					Orientation		NE-SW
Trench devoid of archaeology. Consisted of ploughsoil overlying natural geology of silty sand with gravel.					Length (m)		30
					Width (m)		2
					Avg. depth (m)		0.4
Context No.	Type	Fill Of	Width (m)	Depth (m)	Description	Finds	Date
9300	Layer			0.4	Ploughsoil. Mid grey brown, silt sand, friable.		
9301	Layer				Natural. Mid brownish orange, silty sand with gravel inclusions.		

<b>Trench 94</b>							
General description					Orientation		E-W
Trench contains one pit. Consisted of ploughsoil overlying natural geology of silty sand with gravels.					Length (m)		30
					Width (m)		2
					Avg. depth (m)		0.35
Context No.	Type	Fill Of	Width (m)	Depth (m)	Description	Finds	Date
9400	Layer			0.35	Ploughsoil. Dark grey brown, silty sand		



9401	Layer				Natural. Mid brown orange, silty sand with gravel		
9402	Cut		0.45	0.12	Pit		
9403	Fill	9402			Deliberate Backfill. Dark brown grey, silty sand, rich in charcoal		

Trench 95							
General description						Orientation	NE-SW
Trench contains two pits and two ditches, one of which remains unexcavated. Consisted of ploughsoil overlying natural geology of silty sand with gravel.						Length (m)	30
						Width (m)	2
						Avg. depth (m)	0.3
Context No.	Type	Fill Of	Width (m)	Depth (m)	Description	Finds	Date
9500	Layer			0.3	Ploughsoil. Mid grey brown silt sand, friable		
9501	Layer				Natural. Light orange brown, silt sand with gravel inclusions throughout.		
9502	Layer			0.1	Subsoil. Mid orangish brown, gravel sand silt, loose		
9503	Cut		1.02	0.19	Ditch	CBM	PMED
9504	Fill	9503	1.02	0.19	Primary Fill. Dark brownish black, silty gravel, frequent stones, fill of ditch 9503		
9505	Cut		2	0.4	Pit	Bu Flint	

9506	Fill	9505	1.24	0.1	Primary Fill. Light greyish brown, silty sand, frequent stones		
9507	Fill	9505	0.96	0.4	Primary Fill. Deposit of burnt material, sandy silt, frequent stones		
9508	Fill	9505	0.7	0.34	Primary Fill. Mid orangish brown, sandy silt, frequent stones		
9509	Fill	9505	0.2	0.4	Primary Fill. Dark greyish brown, sandy silt, frequent stones		
9510	Cut		1.63	0.32	Pit		
9511	Fill	9510	1.2	0.32	Primary Fill. Dark bluish black, burnt fill, sample taken, silty sand, frequent stone		
9512	Fill	9510	0.42	0.16	Primary Fill. Light whitish grey, silty sand, frequent stone		
9513	Unexcavated feature		0.65		Ditch. Fill is mid grey brown, silty sand.		
9514	Void						

<b>Trench 96</b>		
General description	Orientation	NW-SE
Trench revealed two ditches. Consisted of ploughsoil overlying natural geology of silty sand with gravel	Length (m)	50
	Width (m)	2
	Avg. depth (m)	0.4

Context No.	Type	Fill Of	Width (m)	Depth (m)	Description	Finds	Date
9600	Layer			0.36	Ploughsoil. Dark grey brown, silty sand		
9601	Layer				Natural. Mid brown orange, silty sand with gravel		
9602	Cut		1.3	0.5	Ditch		
9603	Fill	9602	0.6	0.3	Deliberate Backfill. Mid-brown, friable, silty, gravelly sand.		
9604	Fill	9602	0.7	0.12	Secondary Fill. Yellowish grey, friable gravel.		
9605	Fill	9602	1.2	0.2	Deliberate Backfill. Dark grey, soft, silty, gravelly sand with occasional charcoal flecks.		
9606	Fill	9602	0.8	0.2	Deliberate Backfill. Mid-brown, soft silty, gravelly sand.		
9607	Cut		1.8	0.66	Ditch. Probably same as [9802]		
9608	Fill	9607	0.4	0.1	Primary Fill. Loose, light brown silty sand		
9609	Fill	9607	0.97	0.26	Deliberate Backfill. Loose, mid to dark greyish brown silty sand.		
9610	Fill	9607	1.8	0.42	Deliberate Backfill. Loose, mid brown silty sand		

### Trench 97

General description	Orientation	NW-SE
---------------------	-------------	-------

Trench devoid of archaeology. Consisted of ploughsoil and subsoil overlying natural geology of silty sand with gravels.						Length (m)	30
						Width (m)	2
						Avg. depth (m)	0.5
Context No.	Type	Fill Of	Width (m)	Depth (m)	Description	Finds	Date
9700	Layer			0.3	Ploughsoil. Mid grey brown, silty sand, friable		
9701	Layer			0.19	Subsoil. Mid orange brown, silt sand, friable		
9702	Layer				Natural. Mid brown orange, silt sand, friable, gravel inclusions		

<b>Trench 98</b>													
Trench contained 2 ditches and 3 natural features present. Consisted of ploughsoil overlying natural geology of silty sand with gravels.						Orientation	NE-SW						
						Length (m)	30						
						Width (m)	2						
						Avg. depth (m)	0.35						
						Context No.	Type	Fill Of	Width (m)	Depth (m)	Description	Finds	Date
						9800	Layer		2	0.38	Ploughsoil. Dark grey brown, silty sand		
9801	Layer				Natural. Mid brown orange, silty sand with gravel								
9802	Cut		1.1	0.56	Ditch. Probably same as [9607]								
9803	Cut		1.2	0.66	Natural Feature								
9804	Cut		0.7	0.4	Natural Feature								
9805	Cut		0.4	0.38	Natural Feature								
9806	Cut		1.2	0.3	Ditch								

9807	Fill	9806	1.08	0.23	Deliberate Backfill. Loose, dark grey silty sand	CBM	LC15-EC17
9808	Fill	9806	0.9	0.15	Deliberate Backfill. Loose, dark greyish brown silty sand.		
9809	Fill	9802	0.78	0.26	Deliberate Backfill. Loose, mid to dark greyish brown silty sand.		
9810	Fill	9802	1.1	0.34	Deliberate Backfill. Loose, mid brown silty sand.		
9811	Fill	9803	1.2	0.66	Primary Fill. Loose, light greyish mid brown silty sand.		
9812	Fill	9804	0.7	0.4	Primary Fill. Loose, mid greyish brown sandy silt.		
9813	Fill	9805	0.4	0.38	Primary Fill. Loose, mid brown sandy silt.		

### Trench 99

General description						Orientation	N-S
Trench contained one ditch. Consists of ploughsoil and subsoil overlaying the natural geology silty sand.						Length (m)	30
						Width (m)	2
						Avg. depth (m)	0.4
Context No.	Type	Fill Of	Width (m)	Depth (m)	Description	Finds	Date
9900	Layer			0.24	Ploughsoil. Dark grey brown, silty sand		
9901	Layer			0.16	Subsoil. Mid grey brown, silty sand		
9902	Cut		0.39	0.08	Ditch. Shallow gully.		

9903	Fill	9902	0.39	0.08	Primary Fill. Light brownish grey silty sand. Friable.	
9904	Layer				Natural. Mid brown yellow silty sand	

Trench 100							
General description						Orientation	N-S
Trench revealed one tree throw and a natural excavated feature. Consists of ploughsoil overlying natural geology of gravelly sand with silty patches.						Length (m)	30
						Width (m)	2
						Avg. depth (m)	0.41
Context No.	Type	Fill Of	Width (m)	Depth (m)	Description	Finds	Date
10000	Layer			0.41	Ploughsoil. Dark greyish brown, silty sand		
10001	Layer				Natural. Mid orangish brown, gravel sand with silty patches		
10002	Cut		1.78	0.3	Tree Throw		
10003	Fill	10002	1.78	0.3	Primary Fill. Mid greyish brown, silty sand		
10004	Unexcavated feature		1.71		Natural Feature. Mid greyish brown, silty sand		

Trench 101			
General description		Orientation	NW-SE
Trench devoid of archaeology. Consists of a ploughsoil overlaying the natural geology of silty sand with gravel.		Length (m)	30
		Width (m)	2
		Avg. depth (m)	0.53

Context No.	Type	Fill Of	Width (m)	Depth (m)	Description	Finds	Date
10100	Layer			0.34	Ploughsoil. Dark grey brown, silty sand		
10101	Layer				Natural. Mid brown orange, silty sand with gravel		

<b>Trench 102</b>							
General description					Orientation		NE/SW
Trench revealed one pit and one ditch terminus. Consisted of ploughsoil and subsoil overlying natural geology of silty sand with gravels.					Length (m)		35
					Width (m)		2
					Avg. depth (m)		0.49
Context No.	Type	Fill Of	Width (m)	Depth (m)	Description	Finds	Date
10200	Layer			0.4	Ploughsoil. Dark grey brown, sandy silt.		
10201	Layer			0.09	Subsoil. Mid orange brown, silty sand, friable		
10202	Layer				Natural. Mid brown orange, gravelly silty sand, friable		
10203	Cut		1.2	0.28	Pit		
10204	Fill	10203		0.28	Secondary Fill. Mid grey brown sand silt with occasional small sub-rounded stone and gravel inclusions.		
10205	Cut		0.8	0.33	Ditch		
10206	Fill	10205		0.33	Secondary Fill. Mid grey brown sand silt with occasional small sub-rounded stone and gravel inclusions.		

Trench 103							
General description					Orientation		NE-SW
Trench revealed one ditch and one pit. Consists of ploughsoil and subsoil overlying natural geology of silty sand.					Length (m)		30
					Width (m)		2
					Avg. depth (m)		0.44
Context No.	Type	Fill Of	Width (m)	Depth (m)	Description	Finds	Date
10300	Layer			0.2	Ploughsoil. Mid grey brown silty sand, friable		
10301	Layer			0.14	Subsoil. Mid orange brown, silt sand, friable		
10302	Layer				Natural. Light brownish yellow, silty sand, friable		
10303	Cut		0.87	0.25	Ditch		
10304	Fill	10303	0.87	0.25	Primary Fill		
10305	Cut		1.3	0.5	Pit		
10306	Fill	10305	1.3	0.5	Primary Fill		

Trench 104							
General description					Orientation		E-W
Trench devoid of archaeology. Consists of ploughsoil and subsoil overlying natural geology of silty sand with gravels.					Length (m)		30
					Width (m)		2
					Avg. depth (m)		0.4
Context No.	Type	Fill Of	Width (m)	Depth (m)	Description	Finds	Date
10400	Void						
10401	Void						



10402	Layer			0.28	Ploughsoil. Friable, dark greyish brown, sandy silt.		
10403	Layer			0.26	Subsoil. Friable, Mid orangey brown, sandy silt, mod sub-rounded small stones		
10404	Layer				Natural. Loose/soft, Light yellowish brown, sand, frequent small to medium sized sub-rounded stone		

Trench 105							
General description					Orientation		NW-SE
Trench devoid of archaeology. Consisted of ploughsoil and subsoil overlying natural geology of sand and gravels.					Length (m)		30
					Width (m)		2
					Avg. depth (m)		0.48
Context No.	Type	Fill Of	Width (m)	Depth (m)	Description	Finds	Date
10500	Layer			0.36	Ploughsoil. Mid brown grey sand silt		
10501	Layer			0.12	Subsoil. Light brown yellow sand and gravel		
10502	Layer				Natural. Mid brown yellow sand and gravel		

Trench 106							
General description					Orientation		E-W
Trench devoid of archaeology. Consisted of ploughsoil and subsoil overlying natural geology of silty sand with gravels.					Length (m)		30
					Width (m)		2
					Avg. depth (m)		0.5
Context No.	Type	Fill Of	Width (m)	Depth (m)	Description	Finds	Date

10600	Layer			0.4	Ploughsoil. Dark grey brown, silty sand.		
10601	Layer			0.1	Subsoil. Mid orange brown, silty sand, friable, frequent stone/gravel inclusions		
10602	Layer				Natural. Mid brown orange, silty sand, friable, frequent stone/gravel inclusions		

Trench 107							
General description						Orientation	NW-SE
Trench revealed one tree throw and seven pits. Consisted of ploughsoil overlying natural geology of silty sand.						Length (m)	50
						Width (m)	2
						Avg. depth (m)	0.32
Context No.	Type	Fill Of	Width (m)	Depth (m)	Description	Finds	Date
10700	Layer			0.36	Ploughsoil. Mid grey brown silty sand		
10701	Layer				Natural. Mid orange brown silty sand		
10702	Cut		0.49	0.09	Natural Feature		
10703	Fill	10702	0.49	0.09	Primary Fill. Dark grey brown silty sand		
10704	Cut		0.9	0.26	Pit		
10705	Fill	10704			Primary Fill. No finds.	Flint	EPREH
10706	Fill	10704		0.04	Primary Fill. No finds		
10707	Cut		0.92	0.3	Pit		
10708	Fill	10707			Primary Fill. No finds		
10709	Fill	10707		0.24	Primary Fill. No finds		
10710	Cut		1.54	0.3	Tree Throw		
10711	Void						

10712	Fill	10710			Secondary Fill. 1 flint	Flint	EPREH
10713	Cut		0.54	0.26	Pit		
10714	Fill	10713		0.26	Placed Deposit. Burnt stone		
10715	Cut		0.48	0.1	Pit		
10716	Fill	10715			Placed Deposit. Burnt stone (not retained)	Bu Flint	
10717	Cut		0.13	0.17	Pit		
10718	Fill	10717			Placed Deposit. Burnt stone (not retained)		
10719	Cut		0.4	0.1	Pit		
10720	Fill	10719			Primary Fill. No finds		

### Trench 108

General description					Orientation	E-W	
Trench devoid of archaeology. Consisted of ploughsoil overlying natural geology of silty sand with gravel.					Length (m)	20	
					Width (m)	2	
					Avg. depth (m)	0.37	
Context No.	Type	Fill Of	Width (m)	Depth (m)	Description	Finds	Date
10800	Layer			0.37	Ploughsoil. Dark grey brown, silty sand, friable, frequent stone inclusions		
10801	Layer				Natural. Light brown orange, silty sand, loose, frequent stone/gravel inclusions		

### Trench 109

General description					Orientation	E-W
Trench devoid of archaeology. Consisted of ploughsoil and subsoil overlying natural geology of clayey sand with gravel.					Length (m)	30
					Width (m)	2

						Avg. depth (m)	0.5
Context No.	Type	Fill Of	Width (m)	Depth (m)	Description	Finds	Date
10900	Layer			0.27	Ploughsoil. Dark grey brown, clayey silt, moderately compact		
10901	Layer			0.18	Subsoil. Mid orange brown, clayey silt, moderately compact		
10902	Layer				Natural. Mid brown orange, clayey sand with sandy gravel patches, moderately compact		

<b>Trench 109</b>							
General description					Orientation	E-W	
Trench devoid of archaeology. Consisted of ploughsoil and subsoil overlying natural geology of clayey sand with gravel.					Length (m)	30	
					Width (m)	2	
					Avg. depth (m)	0.5	
Context No.	Type	Fill Of	Width (m)	Depth (m)	Description	Finds	Date
10900	Layer			0.27	Ploughsoil. Dark grey brown, clayey silt, moderately compact		
10901	Layer			0.18	Subsoil. Mid orange brown, clayey silt, moderately compact		
10902	Layer				Natural. Mid brown orange, clayey sand with sandy gravel patches, moderately compact		

<b>Trench 111</b>
-------------------

General description						Orientation	NE-SW
Trench revealed 1 small linear and one elongated pit. Consisted of ploughsoil and subsoil overlying natural geology of silty sand.						Length (m)	30
						Width (m)	2
						Avg. depth (m)	0.5
Context No.	Type	Fill Of	Width (m)	Depth (m)	Description	Finds	Date
11100	Layer			0.37	Ploughsoil. Mid grey brown silt sand, friable		
11101	Layer			0.14	Subsoil. Mid orange brown silt sand, friable		
11102	Layer				Natural. Light brownish yellow, silt sand, loose		
11103	Cut		1.12	0.23	Ditch		
11104	Fill	11103			Primary Fill	Flint	
11105	Cut		2.14x1	0.14	Pit		
11106	Fill	11105			Primary Fill	Pot, BU Flint	LBA/IA

<b>Trench 112</b>							
General description						Orientation	NW-SE
Trench revealed one ditch. Consisted of ploughsoil overlying natural geology silty sand with gravel.						Length (m)	30
						Width (m)	2
						Avg. depth (m)	0.37
Context No.	Type	Fill Of	Width (m)	Depth (m)	Description	Finds	Date
11200	Layer			0.37	Ploughsoil. Dark grey brown, silty sand, friable, frequent stone inclusions		

11201	Layer				Natural. Mid brown orange, silty sand, frequent stone/gravel inclusions, loose		
11202	Cut		0.86	0.1	Ditch		
11203	Fill	11202	0.86	0.1	Secondary Fill. Mid grey brown, silty sand		

Trench 113							
General description					Orientation		E-W
Trench contains a tree-throw hole. Consisted of ploughsoil overlying natural geology of silty sand.					Length (m)		30
					Width (m)		2
					Avg. depth (m)		0.32
Context No.	Type	Fill Of	Width (m)	Depth (m)	Description	Finds	Date
11300	Layer			0.32	Ploughsoil. Dark grey brown, silty sand, friable		
11301	Layer				Natural. Mid brown orange with patches of light brown yellow, silty sand, loose		
11302	Void						
11303	Cut		0.6	0.14	Natural Feature. Sub-oval shape in plan, gentle to moderately sloping sides, flat slightly irregular base		
11304	Fill	11303	0.6	0.14	Primary Fill. Dark brown grey/black, silty sand, friable	Bu Flint	

Trench 115			
General description		Orientation	E-W
		Length (m)	30

Trench contains one ditch and one tree throw. Consists of a ploughsoil overlying the natural geology of silty sand.						Width (m)	2
						Avg. depth (m)	0.57
Context No.	Type	Fill Of	Width (m)	Depth (m)	Description	Finds	Date
11500	Layer			0.57	Ploughsoil. Dark greyish brown		
11501	Layer				Natural. Light brownish orange, silty sand		
11502	Cut		0.84	0.14	Ditch		
11503	Fill	11502	0.84	0.14	Primary Fill. Mid greyish brown		
11504	Cut		1.03	0.58	Tree Throw		
11505	Fill	11504			Primary Fill. Light greyish brown	Bu Flint	

<b>Trench 116</b>													
General description						Orientation	E-W						
						Trench devoid of archaeology. Consists of ploughsoil and subsoil overlying natural geology of clayey sand and patches of silty sand.						Length (m)	30
												Width (m)	2
Avg. depth (m)	0.4												
Context No.	Type	Fill Of	Width (m)	Depth (m)	Description	Finds	Date						
11600	Layer			0.3	Ploughsoil. Dark grey brown, sandy silt, friable								
11601	Layer			0.1	Subsoil. Mid orange brown, silty sand, friable								
11602	Layer				Natural. Mid brown orange, clayey sand with areas of silty sand								

<b>Trench 117</b>
-------------------

General description						Orientation	E-W
Trench revealed one pit in NW corner. Trench consists of ploughsoil and subsoil overlying natural geology of silty sand with gravel.						Length (m)	15
						Width (m)	10
						Avg. depth (m)	0.51
Context No.	Type	Fill Of	Width (m)	Depth (m)	Description	Finds	Date
11700	Layer			0.38	Ploughsoil. Dark greyish brown, silty sand		
11701	Layer			0.13	Subsoil. Mid greyish brown, silty sand		
11702	Layer				Natural. Mid orangish brown, silty sand with gravel patches		
11703	Cut		2	0.3	Pit		
11704	Fill	11703	2	0.3	Primary Fill. Dark greyish brown, silty sand		

<b>Trench 118</b>							
General description						Orientation	NE-SW
Trench revealed three ditches, two pits and one natural feature. Consisted of ploughsoil overlying natural geology of gravels with sandy patches.						Length (m)	30
						Width (m)	2
						Avg. depth (m)	0.36
Context No.	Type	Fill Of	Width (m)	Depth (m)	Description	Finds	Date
11800	Layer			0.34	Ploughsoil. Dark grey friable silty gravelly sand.		
11801	Layer				Natural. Mid-orange-brown friable gravel with sandy patches.		
11802	Cut		0.6	0.36	Pit		



11803	Fill	11802	0.5	0.18	Deliberate Backfill. Mid-grey soft silty, gravelly sand. Contained charcoal.		
11804	Fill	11802	0.6	0.18	Deliberate Backfill. Mid-greyish brown soft silty, gravelly sand. Contained heat affected stones.	Bu Flint	
11805	Cut		1.26	0.34	Ditch		
11806	Fill	11805	1.26	0.26	Deliberate Backfill. Loose dark grey gravelly silty sand.	Bu Flint	
11807	Fill	11805	0.46	0.06	Secondary Fill. Loose, mid orange brown gravelly silty sand.		
11808	Fill	11805	0.7	0.08	Deliberate Backfill. Soft, mid brownish grey silty sand with gravel.		
11809	Cut		0.72	0.22	Ditch		
11810	Fill	11809	0.72	0.22	Deliberate Backfill. Loose mid brownish grey, sandy gravel		
11811	Cut		0.46	0.18	Pit		
11812	Fill	11811	0.4	0.08	Deliberate Backfill. Dark brown, soft, silty gritty sand with occasional charcoal.		
11813	Fill	11811	0.48	0.1	Secondary Fill. Mid-brown, soft/friable silty gravelly sand.		
11814	Cut		0.8	0.28	Ditch		
11815	Fill	11814	0.8	0.28	Deliberate Backfill. Dark grey, friable silty, gravelly sand.		
11816	Cut		0.6	0.2	Other Cut. Feature goes under the L.O.E. Unknown, can be		

					shallow ditch terminus or shallow oval pit.	
11817	Fill	11816	0.6	0.2	Deliberate Backfill. Mid-greyish brown, friable silty, gravelly sand.	

Trench 119							
General description					Orientation	E-W	
Trench contained two ditches and one posthole. Consists of a ploughsoil overlying natural geology of silty sand with gravel.					Length (m)	30	
					Width (m)	2	
					Avg. depth (m)	0.34	
Context No.	Type	Fill Of	Width (m)	Depth (m)	Description	Finds	Date
11900	Layer			0.34	Ploughsoil. Dark grey brown, silty sand		
11901	Layer				Natural. Mid brown orange, silty sand with gravel		
11902	Cut		1.1	0.28	Ditch		
11903	Fill	11902	1.1	0.28	Secondary Fill. Mid grey brown, silty sand		
11904	Cut		0.4	0.21	Posthole		
11905	Fill	11904	0.4	0.21	Secondary Fill. Light grey brown, silty sand		
11906	Cut		0.74	0.26	Ditch		
11907	Fill	11906	0.74	0.26	Secondary Fill. Mid grey brown, silty sand	Pot	MBA/LBA

Trench 120			
General description		Orientation	NE-SW
Trench revealed two ditches and one tree throw. Consisted of ploughsoil overlying natural geology of sandy gravel.		Length (m)	30
		Width (m)	2

						Avg. depth (m)	0.3
Context No.	Type	Fill Of	Width (m)	Depth (m)	Description	Finds	Date
12000	Layer			0.3	Ploughsoil. Dark grey, friable, silty gravelly sand.		
12001	Layer				Natural. Friable, mid orange brown sandy gravel.		
12002	Cut		0.5	0.14	Ditch		
12003	Fill	12002	0.5	0.14	Deliberate Backfill. Loose, mid to dark grey silty sand with pebbles.		
12004	Cut		0.68	0.14	Ditch		
12005	Fill	12004	0.68	0.14	Deliberate Backfill. Loose, mid to dark grey silty sand with pebbles.		
12006	Cut		1.5	0.22	Tree Throw		
12007	Fill	12006	1.5	0.22	Primary Fill. Loose, mid greyish brown silty sand.		

<b>Trench 121</b>							
General description					Orientation	N-S	
Trench devoid of archaeology. Consisted of ploughsoil and subsoil overlying natural geology of clayey sand with patches of silty sand.					Length (m)	30	
					Width (m)	2	
					Avg. depth (m)	0.47	
Context No.	Type	Fill Of	Width (m)	Depth (m)	Description	Finds	Date
12100	Layer			0.29	Ploughsoil. Dark grey brown, clayey sand, moderately compact		

12101	Layer			0.18	Subsoil. Mid orange brown, clayey sand, moderately compact		
12102	Layer				Natural. Mid brown orange, clayey sand with patches of silty sand		

### Trench 122

General description					Orientation	NW-SE	
Trench devoid of archaeology. Consisted of ploughsoil and subsoil overlying colluvial layer and natural geology of silty sand					Length (m)	30	
					Width (m)	2	
					Avg. depth (m)	1	
Context No.	Type	Fill Of	Width (m)	Depth (m)	Description	Finds	Date
12200	Layer			0.33	Ploughsoil. Dark grey brown, silty clay		
12201	Layer			0.45	Subsoil. Mid orangey brown, silty sand		
12202	Layer			0.5	Colluvial Layer. Light greyish brown, sandy silt, firm. Frequent rooting and pot fragments in it	Pot	LBA/IA
12203	Layer				Natural. Light orangey yellow, silty sand. Only exposed on NW end of trench		

### Trench 123

General description					Orientation	E-W
Trench devoid of archaeology. Consist of ploughsoil and subsoil overlying colluvial layer. Natural geology not exposed					Length (m)	30
					Width (m)	2
					Avg. depth (m)	1

Context No.	Type	Fill Of	Width (m)	Depth (m)	Description	Finds	Date
12300	Layer			0.36	Ploughsoil. Dark grey brown, silty clay	Flint	
12301	Layer			0.5	Subsoil. Mid reddish/orangey brown, sandy silt. Some finds	Pot, Flint	LBA/IA
12302	Layer			0.8	Colluvial Layer. Light orange yellowy brown, silt		
12303	Layer			1.04	Colluvial Layer. Mid orangey brown silt		
12304	Layer				Colluvial Layer. Mid orangey brown sandy silt. Not bottomed.		
12305	Void						
12306	Cut		3.06	1.1	Ditch. Not bottomed. Possibly a paleochannel		
12307	Fill	12306	1.16	0.28	Secondary Fill. Looks colluvial		
12308	Fill	12306	1.2	1.1	Other Fill. Firm, light bluish white, sandy silt		
12309	Fill	12306	1.7	0.93	Secondary Fill. Firm, mid orangey brown, sandy silt		
12310	Cut		1.2	0.63	Tree Throw. Only seen in section		
12311	Fill	12310	1.2	0.63	Secondary Fill. Firm, mid brown, sandy silt		
12312	Fill	12310	0.5	0.5	Secondary Fill. Firm, mid orangey brown, sandy silt.		

## Trench 124

General description	Orientation	E-W
---------------------	-------------	-----

Trench devoid of archaeology. Consisted of ploughsoil and subsoil overlying colluvial layer and natural geology of sand.						Length (m)	30
						Width (m)	2
						Avg. depth (m)	1
Context No.	Type	Fill Of	Width (m)	Depth (m)	Description	Finds	Date
12400	Layer			0.3	Ploughsoil. Dark grey brown, silty clay		
12401	Layer			0.45	Subsoil. Mid orangey brown, silty sand		
12402	Layer			0.15	Colluvial Layer		
12403	Layer				Natural. Mid yellow brown, sand		

<b>Trench 125</b>													
General description						Orientation	NE-SW						
						Trench devoid of archaeology. Consists of ploughsoil, subsoil and colluvium overlying natural geology of silty sand.						Length (m)	30
												Width (m)	2.1
Avg. depth (m)	1												
Context No.	Type	Fill Of	Width (m)	Depth (m)	Description	Finds	Date						
12500	Layer			0.3	Ploughsoil. Dark grey brown, clayey silt								
12501	Layer			0.5	Subsoil. Mid orange brown, clayey sand								
12502	Layer			0.2	Colluvial Layer. Mid orange brown, sandy clay								
12503	Layer				Natural. Mid brown yellow, silty sand								

<b>Trench 126</b>							
General description						Orientation	NE-SW

Trench devoid of archaeology. Consists of ploughsoil and subsoil overlying colluvial layer and natural geology of clayey sand.						Length (m)	30
						Width (m)	2.1
						Avg. depth (m)	1
Context No.	Type	Fill Of	Width (m)	Depth (m)	Description	Finds	Date
12600	Void						
12601	Layer			0.3	Ploughsoil. Dark grey brown, clayey silt		
12602	Layer			0.5	Subsoil. Mid orange brown, clayey sand		
12603	Layer			0.2	Colluvial Layer. Light grey yellow/brown, silty sand		
12604	Layer				Natural. Light brown orange, clayey sand		

<b>Trench 127</b>													
Trench devoid of archaeology. Consists of ploughsoil and subsoil overlying colluvium. Natural geology not reached.						Orientation	NW-SE						
						Length (m)	30						
						Width (m)	2.1						
Trench devoid of archaeology. Consists of ploughsoil and subsoil overlying colluvium. Natural geology not reached.						Avg. depth (m)	0.7						
						Context No.	Type	Fill Of	Width (m)	Depth (m)	Description	Finds	Date
						12700	Layer			0.29	Ploughsoil. Dark grey brown, clayey silt	Flint	?EPREH, LPREH
12701	Layer			0.46	Subsoil. Mid orange brown, clayey sandy silt								
12702	Layer			0.62	Colluvial Layer. Light orangey brown sandy silt layers								
12703	Layer			0.74	Colluvial Layer								

Trench 128							
General description					Orientation		N-S
Trench devoid of archaeology. Consists of ploughsoil and subsoil overlying two colluvial layers and natural geology of silty sand.					Length (m)		30
					Width (m)		2.1
					Avg. depth (m)		1.25
Context No.	Type	Fill Of	Width (m)	Depth (m)	Description	Finds	Date
12800	Layer			0.25	Ploughsoil. Dark grey brown, clayey silt		
12801	Layer			0.3	Subsoil. Mid orange brown, clayey silt		
12802	Layer			0.4	Colluvial Layer. Light grey yellow, silty sand		
12803	Layer			0.3	Colluvial Layer. Mid grey brown, clayey sand		
12804	Layer				Natural. Light brown orange and yellow, silty sand		

Trench 129							
General description					Orientation		NE-SW
Trench has one natural feature. Consists of ploughsoil and subsoil overlying colluvial layer and natural geology of silty sand with gravel patches.					Length (m)		30
					Width (m)		2
					Avg. depth (m)		1
Context No.	Type	Fill Of	Width (m)	Depth (m)	Description	Finds	Date
12900	Layer			0.3	Ploughsoil. Dark grey brown, silty clay		
12901	Layer			0.45	Subsoil. Mid orangey brown, silty sand. Getting thicker towards NE, downhill. Only		



					0.3m deep on SW end, overlying natural 12903		
12902	Layer			0.25	Colluvial Layer. Light grey brown, clayey sand. Only visible on NE half of trench, getting thicker towards NE, downhill		
12903	Layer				Natural. Mid red yellow, silty sand with gravel patches		
12904	Cut		2.9		Natural Feature. Natural depression with irregular base filled with colluvium layer (12902).		

Trench 130							
General description					Orientation		E-W
Trench devoid of archaeology. Consists of ploughsoil and subsoil and deep colluvium deposits overlying natural geology of silty sand.					Length (m)		30
					Width (m)		2.1
					Avg. depth (m)		0.75
Context No.	Type	Fill Of	Width (m)	Depth (m)	Description	Finds	Date
13000	Layer			0.3	Ploughsoil. Dark grey brown, clayey silt		
13001	Layer			0.2	Subsoil. Mid orange brown, clayey sand		
13002	Layer				Natural. Light brown yellow to mid brown orange, silty sand		
13003	Layer		9	0.55	Colluvial Layer. Mid orange brown, silty sand. Unknown total depth as it goes deeper than 1M L.O.E		



Trench 131							
General description					Orientation		NE-SW
Trench revealed two pits, one of which remains unexcavated. Consists of ploughsoil, subsoil and colluvium overlying natural geology of silty sand.					Length (m)		30
					Width (m)		2.1
					Avg. depth (m)		1
Context No.	Type	Fill Of	Width (m)	Depth (m)	Description	Finds	Date
13100	Layer			0.3	Ploughsoil. Dark grey brown, clayey silt		
13101	Layer			0.5	Subsoil. Mid brown orange, clayey sand		
13102	Layer			0.2	Colluvial Layer. Mid orange brown, sandy clay		
13103	Layer				Natural. Light brown yellow to mid brown orange, silty sand with patches of sandy clay		
13104	Cut		1.6	0.89	Pit. Only visible in baulk		
13105	Fill	13104	1	0.16	Secondary Fill. Firm, mottled brownish grey and orange brown, sandy silt		
13106	Fill	13104	1.5	0.82	Secondary Fill. Firm, mottled mid brownish grey and orangey brown, sandy silt		

13107	Fill	13104	0.8	0.68	Secondary Fill. Firm, mid orangey brown, sandy silt	Pot, Flint	LBA/IA
13108	Unexcavated feature		0.62		Pit. Fill in plan - mid grey brown silty sand, infrequent charcoal inclusions		
13109	Void						
13110	Void						

### Trench 132

General description					Orientation	N-S	
Trench devoid of archaeology. Consists of ploughsoil, subsoil and colluvium overlying natural geology of silty sand and clay.					Length (m)	30	
					Width (m)	2.1	
					Avg. depth (m)	1	
Context No.	Type	Fill Of	Width (m)	Depth (m)	Description	Finds	Date
13200	Layer			0.3	Ploughsoil. Dark grey brown, clayey sand		
13201	Layer			0.53	Subsoil. Mid reddish brown, clayey sandy silt		
13202	Layer			0.8	Subsoil. Mid orange brown, sandy silt		
13203	Layer				Natural. Mid orangey brown, silty sand		
13204	Layer			0.12	Colluvial Layer. Mid orangey yellowy brown clayey silt		
13205	Layer			0.34	Colluvial Layer. Light yellowish-brown clayey silt, mottled with light yellowish white chalky silt		

Trench 133							
General description					Orientation		
Not excavated. Trench located under low overhead power lines.					Length (m)		
					Width (m)		
					Avg. depth (m)		
Context No.	Type	Fill Of	Width (m)	Depth (m)	Description	Finds	Date

Trench 134							
General description					Orientation		N-S
Trench revealing one linear ditch. Consists of ploughsoil overlying a sandy gravel natural.					Length (m)		30
					Width (m)		2
					Avg. depth (m)		0.4
Context No.	Type	Fill Of	Width (m)	Depth (m)	Description	Finds	Date
13400	Layer			0.3	Ploughsoil. Mid brownish grey, silty loam, soft.		
13401	Layer				Natural. Light reddish brown, gravelly sand, soft.		
13402	Cut		1.56	0.48	Ditch. Cut of linear ditch, E-W		
13403	Fill	13402	1.32	0.16	Primary Fill. Light grey/yellow brown, sandy silt		
13404	Fill	13402	0.96	0.12	Secondary Fill. Mid grey brown, sandy silt and gravel		
13405	Fill	13402	1.14	0.28	Secondary Fill. Mid grey brown, sandy silt	Pot, Flint	LBA/IA, ?L Neo

Trench 135							
General description					Orientation		N-S
Trench revealed one modern ditch. Consists of plough soil overlying a thin subsoil and a sandy gravel natural geology.					Length (m)		30
					Width (m)		2
					Avg. depth (m)		0.44
Context No.	Type	Fill Of	Width (m)	Depth (m)	Description	Finds	Date
13500	Layer			0.26	Ploughsoil. Mid brownish grey, soft, silty loam		
13501	Layer			0.06	Subsoil. Lid reddish brown, sandy silt, soft. Not present in whole trench		
13502	Layer				Natural. Light reddish brown, silty sand, soft		
13503	Unexcavated feature		1.1		Modern. Fill is a dark brown grey, silty sand.		

Trench 136							
General description					Orientation		NE-SW
Trench contains two ditches, one pit and one tree throw. Consisted of ploughsoil and subsoil overlying natural geology of gravelly sand.					Length (m)		30
					Width (m)		2
					Avg. depth (m)		0.55
Context No.	Type	Fill Of	Width (m)	Depth (m)	Description	Finds	Date
13600	Layer			0.3	Ploughsoil. Mid brownish grey, silty loam, soft		
13601	Layer			0.45	Subsoil. Mid reddish brown, sand silt, soft		

13602	Layer				Natural. Light yellowish brown, gravelly sand, soft		
13603	Cut		1.08	0.28	Ditch.		
13604	Fill	13603	1.08	0.28	Secondary Fill. Light brown grey, sandy silt w/gravel	Pot	LBA/EIA
13605	Cut		0.57	0.21	Pit. Sub-circular pit, gentle concave sides to concave base		
13606	Fill	13605	0.57	0.21	Tertiary Fill. Charcoal rich dark grey silty sand		
13607	Cut		1.01	0.3	Ditch. Gully, imperceptible sides to flat base		
13608	Fill	13607	1.01	0.3	Secondary Fill. Light brownish grey, silty sand, friable.		LBA/IA
13609	Void						
13610	Cut		2.02	0.45	Tree Throw with sterile firm mid orange brown sand fill, no datable material recovered.		

### Trench 137

General description					Orientation	NW-SE	
Trench devoid of archaeology. Consists of ploughsoil and subsoil overlying natural geology of silty sand.					Length (m)	30	
					Width (m)	2	
					Avg. depth (m)	0.7	
Context No.	Type	Fill Of	Width (m)	Depth (m)	Description	Finds	Date
13700	Layer			0.3	Ploughsoil. Mid brownish grey, silty loam, soft		

13701	Layer			0.55	Subsoil. Mid reddish brown, sandy silt, soft		
13702	Layer				Natural. Light greyish yellow, silty sand, soft		

**Trench 138**

General description	Orientation	NW-SE
Trench contained two ditches, one of which remains unexcavated. Consisted of ploughsoil and subsoil overlying natural geology of gravelly sand.	Length (m)	30
	Width (m)	2
	Avg. depth (m)	0.5

Context No.	Type	Fill Of	Width (m)	Depth (m)	Description	Finds	Date
13800	Layer			0.33	Ploughsoil. Mid brownish grey, silty loam, soft		
13801	Layer			0.26	Subsoil. Mid reddish brown, sandy silt, soft		
13802	Layer				Natural. Light brownish yellow, gravelly sand, soft		
13803	Cut		1.3	0.3	Ditch. If real, it is likely a field boundary. Profile and fill strongly suggest this is a natural feature.		
13804	Fill	13803	0.34	0.2	Primary Fill. Mid reddish brown, silty sand, soft, frequent gravel		
13805	Fill	13803	1	0.3	Secondary Fill. Mid reddish brown, sandy silt, soft		
13806	Unexcavated feature		1.4		Ditch. Dark brown grey, silty sand.		



Trench 139							
General description					Orientation	NE-SW	
Trench revealed 3 ditches, and post hole. Consisted of ploughsoil and subsoil overlaying natural geology of sandy gravel.					Length (m)	30	
					Width (m)	2	
					Avg. depth (m)	0.6	
Context No.	Type	Fill Of	Width (m)	Depth (m)	Description	Finds	Date
13900	Layer			0.4	Ploughsoil. Mid brownish grey, silty loam, soft	Flint	EPREH
13901	Layer			0.15	Subsoil. Mid reddish brown, sand silt, soft		
13902	Layer				Natural. Light reddish brown, sandy gravel, loose		
13903	Cut		0.86	0.2	Ditch. Same as [13906] and [13916]		
13904	Fill	13903	0.58	0.1	Secondary Fill. Soft, light greyish brown silty sand.		
13905	Fill	13903	0.86	0.11	Secondary Fill. Soft, mid brown silty sand.	Pot	LBA/IA
13906	Cut		0.5	0.3	Ditch. Same as [13903] and [13916]		
13907	Fill	13906	0.5	0.24	Secondary Fill. Soft, light greyish brown silty sand.	Flint	LNeo-EBA
13908	Fill	13906	0.5	0.07	Secondary Fill. Soft, mid brown silty sand.		
13909	Cut		1.26	0.44	Ditch. Modern, seen on OS map		
13910	Fill	13909	0.96	0.2	Primary Fill. Firm, light brown dark grey silty sand with gravel		

13911	Fill	13909	1.24	0.26	Deliberate Backfill. Soft, dark greyish brown silty sand.		
13912	Cut		0.32	0.06	Posthole		
13913	Fill	13912	0.32	0.06	Deliberate Backfill. Loose, mid brownish grey silty sand.		
13914	Cut		0.73	0.38	Ring Ditch. Steep sided V-shape to a tapered base. Likely and enclosure ditch.		
13915	Fill	13914	0.78	0.27	Secondary Fill. Light brown grey silty sand w/gravel fragments and substantial pottery deposit	Pot	MBA
13916	Cut		0.8	0.2	Ditch. Same as [13903] and [13906]		
13917	Fill	13916	0.8	0.14	Secondary Fill. Soft, light greyish brown silty sand.		
13918	Fill	13916	0.48	0.06	Secondary Fill. Soft, mid brownish grey silty sand.	Pot	MBA
13919	Fill	13914	0.29	0.19	Primary Fill. Light grey red silty sand, w/ frequent manganese		

Trench 140							
General description					Orientation		NW-SE
Trench revealing one ditch. Consists of ploughsoil and subsoil overlying natural geology of silty sand and gravel patches.					Length (m)		30
					Width (m)		2
					Avg. depth (m)		0.4
Context No.	Type	Fill Of	Width (m)	Depth (m)	Description	Finds	Date

14000	Layer			0.3	Ploughsoil. Dark grey brown, silty clay	Flint	
14001	Layer			0.2	Subsoil. Mid orangey brown, clayey sand. Only on SE end of trench, getting thicker that way		
14002	Layer				Natural. Light orange yellow, silty sand and gravel patches		
14003	Cut		0.9	0.35	Ditch. For boundary or drainage		
14004	Fill	14003	0.9	0.35	Secondary Fill. Firm, dark brownish grey, silty clay		

### Trench 141

General description					Orientation	E-W	
Consisted of ploughsoil and subsoil overlying a colluvial layer. Natural geology not exposed					Length (m)	30	
					Width (m)	2	
					Avg. depth (m)	0.45	
Context No.	Type	Fill Of	Width (m)	Depth (m)	Description	Finds	Date
14100	Layer			0.3	Ploughsoil. Mid greyish brown, clay silt		
14101	Layer			0.15	Subsoil. Mid brownish orange, sandy silty clay		
14102	Layer				Colluvial Layer. Mid brownish yellow/orange, sandy silty clay		
14103	Cut		1.4	0.5	Ditch. Not bottomed		
14104	Fill	14103	1.28	0.3	Secondary Fill. Residual BA flint	Flint	
14105	Fill	14103	1.4	0.5	Secondary Fill		

Trench 142							
General description					Orientation		N-S
Trench revealed two ditches. Consisted of a ploughsoil and subsoil overlying colluvium and natural geology of gravelly sand.					Length (m)		30
					Width (m)		2
					Avg. depth (m)		1
Context No.	Type	Fill Of	Width (m)	Depth (m)	Description	Finds	Date
14200	Layer		2	0.32	Ploughsoil. Mid brownish grey, clayey loam, soft		
14201	Layer		2	0.31	Subsoil. Light reddish brown, sandy silt, soft		
14202	Layer		2		Natural. Light reddish yellow. Gravelly sand, soft.		
14203	Cut		0.61	0.18	Ditch. Likely small modern boundary or drainage.		
14204	Fill	14203	0.38	0.14	Secondary Fill. Mid brownish grey, sandy clay, soft		
14205	Fill	14203	0.43	0.12	Secondary Fill. Mid greyish brown, sandy silt, soft.		
14206	Cut		1.1	0.42	Ditch. Modern field boundary as seen on OS map. Also seen in TR 138 and 139		
14207	Fill	14206	1.1	0.42	Primary Fill. Mixed mottled dark brownish grey and mid yellowish brown, sandy silt, soft		
14208	Layer		2	0.32	Colluvial Layer. Mid greyish brown, silty		

				clay, soft, moderate gravel.	
--	--	--	--	------------------------------	--

### Trench 143

General description					Orientation	NE-SW	
Trench devoid of archaeology. Consisted of ploughsoil and subsoil overlying natural geology of gravelly sand.					Length (m)	30	
					Width (m)	2	
					Avg. depth (m)	0.68	
Context No.	Type	Fill Of	Width (m)	Depth (m)	Description	Finds	Date
14300	Layer			0.2	Ploughsoil. Mid brownish grey, silty loam, soft	Flint	
14301	Layer			0.48	Subsoil. Mid reddish brown, sandy silt, soft		
14302	Layer				Natural. Light yellowish brown, gravelly sand, soft.		

### Trench 144

General description					Orientation	NE-SW	
Trench devoid of archaeology. Consists of ploughsoil, subsoil and colluvial overlying natural geology of sand and gravel patches.					Length (m)	30	
					Width (m)	2	
					Avg. depth (m)	1	
Context No.	Type	Fill Of	Width (m)	Depth (m)	Description	Finds	Date
14400	Layer			0.3	Ploughsoil. Dark grey brown, silty clay		
14401	Layer			0.65	Subsoil. Mid orangey brown, clayey sand		

14402	Layer				Natural. Light red yellow, sand and gravel patches		
14403	Layer			0.45	Colluvial Layer. Mid orange brown, silty sand		

Trench 145							
General description					Orientation		N-S
Trench devoid of archaeology. Consists of ploughsoil and subsoil overlying natural geology of sand and gravel					Length (m)		30
					Width (m)		2
					Avg. depth (m)		0.33
Context No.	Type	Fill Of	Width (m)	Depth (m)	Description	Finds	Date
14500	Layer			0.33	Ploughsoil. Dark grey brown, silty clay		
14501	Layer			0.4	Subsoil. Mid orangey brown, clayey sand. Only on S end of trench		
14502	Layer				Natural. Light red yellow, sand and gravel		

Trench 146							
General description					Orientation		NW-SE
Trench revealed one ditch. Trench consists of ploughsoil and subsoil overlying a natural of gravelly sand.					Length (m)		40
					Width (m)		2
					Avg. depth (m)		0.4
Context No.	Type	Fill Of	Width (m)	Depth (m)	Description	Finds	Date
14600	Layer			0.25	Ploughsoil. Mid brown silty clay		

14601	Layer			0.15	Subsoil. Mid orange brown silty sand		
14602	Layer				Natural. Mid orange brown silty sand with some gravel pockets (brickearth/colluvium?)		
14603	Cut		0.66	0.14	Ditch. Only seen in baulk section.		
14604	Fill	14603			Secondary Fill. Mid greyish brown, sandy silt, soft.		

Trench 147							
General description						Orientation	E-W
Trench revealed two ditches. Consists of ploughsoil and subsoil overlying a colluvial layer. Natural geology not exposed.						Length (m)	30
						Width (m)	2
						Avg. depth (m)	0.5
Context No.	Type	Fill Of	Width (m)	Depth (m)	Description	Finds	Date
14700	Layer			0.3	Ploughsoil. Mid brown silty clay	Pot	AD1830-1900
14701	Layer			0.2	Subsoil. Mid orange brown silty sand		
14702	Layer			0.16	Colluvial Layer. Mottled mid orange brown silty sand		
14703	Cut		0.8	0.15	Ditch. Possibly for boundary or drainage purposes. Possibly the same as ditch [14003]		
14704	Fill	14703	0.8	0.15	Secondary Fill. Light brownish grey, sandy silt, soft		
14705	Cut		0.8	0.14	Ditch. Possibly for boundary or drainage purposes.		

14706	Fill	14705	0.8	0.14	Secondary Fill. Light brownish grey, sandy silt, soft	Flint
-------	------	-------	-----	------	-------------------------------------------------------	-------

Trench 148							
General description					Orientation	NE-SW	
Trench devoid of archaeology. Consists of ploughsoil and subsoil overlying a colluvial layer. Natural geology not exposed.					Length (m)	28	
					Width (m)	2	
					Avg. depth (m)	0.5	
Context No.	Type	Fill Of	Width (m)	Depth (m)	Description	Finds	Date
14800	Layer			0.3	Ploughsoil. Mid brownish grey, silty loam, soft		
14801	Layer			0.33	Subsoil. Mid orange brown silty sand		
14802	Layer			0.47	Colluvial Layer. Mottled light orange brown and mid orange brown sandy silt, frequent manganese; sondage cut at west end		
14803	Layer				Natural. Mottled; light yellowish orangey white and mi brownish orange sandy silt		

Trench 149			
General description		Orientation	NE-SW
Trench contained one ditch and one posthole. Consisted of ploughsoil and subsoil overlying colluvium and natural geology of silty sand.		Length (m)	30
		Width (m)	2
		Avg. depth (m)	1



Context No.	Type	Fill Of	Width (m)	Depth (m)	Description	Finds	Date
14900	Layer			0.3	Ploughsoil. Soft, dark grey brown, clay silt		
14901	Layer			0.5	Colluvial Layer. Firm, mid yellow brown, silty clay.		
14902	Layer				Natural. Firm, mid yellow brown, silty sand		
14903	Cut		1.9	0.07	Ditch. Possible boundary ditch		
14904	Fill	14903	1.9	0.07	Secondary Fill. Firm, dark greyish brown, silty clay		
14905	Void						
14906	Void						
14907	Cut		0.3	0.15	Posthole. Sub rectangular, relationship with [14903] uncertain		
14908	Fill	14907	0.3	0.15	Secondary Fill. Firm, dark brownish grey, silty clay		
14909	Layer			0.18	Subsoil. Dark grey brown, silty clay, soft		

<b>Trench 150</b>							
General description					Orientation		N-S
Trench devoid of archaeology. Consisted of ploughsoil and subsoil overlying colluvium.					Length (m)		30
					Width (m)		2
					Avg. depth (m)		0.9
Context No.	Type	Fill Of	Width (m)	Depth (m)	Description	Finds	Date

15000	Layer			0.32	Ploughsoil. Mid brownish grey, silty loam, soft		
15001	Layer			0.17	Subsoil. Light greyish brown, silty sand, soft		
15002	Layer			0.27	Colluvial Layer. Mid greyish brown, sandy silt, soft		

Trench 151							
General description					Orientation		E-W
Trench devoid of archaeology. Consists of ploughsoil and subsoil overlying colluvium and natural geology of silty sand.					Length (m)		30
					Width (m)		2
					Avg. depth (m)		0.9
Context No.	Type	Fill Of	Width (m)	Depth (m)	Description	Finds	Date
15100	Layer			0.3	Ploughsoil. Dark grey brown, silty clay		
15101	Layer			0.6	Subsoil. Mid orangey brown, clayey sand		
15102	Layer				Natural. Light orangey yellow, silty sand		
15103	Layer			0.24	Colluvial Layer. Mid yellow orange, silt sand, friable		

Trench 152							
General description					Orientation		E-W
Trench revealed two unexcavated ditches. Trench consists of ploughsoil and subsoil overlying natural geology of clayey sand.					Length (m)		30
					Width (m)		2
					Avg. depth (m)		0.53
Context No.	Type	Fill Of	Width (m)	Depth (m)	Description	Finds	Date

15200	Layer			0.35	Ploughsoil. Dark grey brown, silty clay		
15201	Layer			0.18	Subsoil. Mid orangey brown, clayey sand		
15202	Layer				Natural. Light grey yellow, clayey sand		
15203	Unexcavated feature		1		Ditch. Linear ditch E-W. Recut of original ditch 15204. Same as ditch 15303	Pot	LBA/IA
15204	Unexcavated feature		0.4		Ditch. Linear ditch, E-W. Original ditch truncated by later recut 15203. Same as ditch 15307	Pot	RO

### Trench 153

General description	Orientation	NW-SE
Trench revealing two linear ditches (cut+recut), same as the ones in Tr.152, and another linear ditch on N end of trench. Trench consists of ploughsoil and subsoil overlying natural geology of clayey sand.	Length (m)	30
	Width (m)	2
	Avg. depth (m)	0.47

Context No.	Type	Fill Of	Width (m)	Depth (m)	Description	Finds	Date
15300	Layer			0.3	Ploughsoil. Dark grey brown, silty clay		
15301	Layer			0.17	Subsoil. Mid orangey brown, clayey sand		
15302	Layer				Natural. Light grey yellow, clayey sand	Flint	EPREH
15303	Cut		1.18	0.52	Ditch. Recut of original ditch [15307]		
15304	Fill	15303	1.18	0.52	Secondary Fill. Light grey, silty sand.	Pot	IA, RO,

					Sampled <18> for enviro and finds purposes		
15305	Cut		1.42	0.16	Ditch. Possible furrow, or shallow boundary		
15306	Fill	15305	1.42	0.16	Secondary Fill. Light grey, silty sand	Pot	LBA/IA
15307	Cut		1	0.58	Ditch. Cut of linear ditch, E-W		
15308	Fill	15307	0.6	0.3	Primary Fill. Light orangey grey, silty sand, friable	Flint	
15309	Fill	15307	0.78	0.38	Secondary Fill. Light grey brown, silty sand		

Trench 155							
General description						Orientation	N-S
Trench revealed eight ditches and seven pits. Trench consists of topsoil and subsoil overlying a colluvial layer. Natural geology not reached.						Length (m)	30
						Width (m)	2
						Avg. depth (m)	0.6
Context No.	Type	Fill Of	Width (m)	Depth (m)	Description	Finds	Date
15500	Layer			0.18	Topsoil. Dark greyish brown clayey silt	Flint	LPREH
15501	Layer			0.2	Subsoil. Mid greyish brown clayey silt	Flint	
15502	Layer				Colluvial Layer. Mid orange brown clayey silt (brickearth/colluvium?)		
15503	Cut		1.05	0.26	Pit	Bu Flint	
15504	Fill	15503	1.05	0.1	Secondary Fill		
15505	Fill	15503	0.7	0.15	Secondary Fill	Bu Flint	

15506	Cut		0.75	0.35	Pit		
15507	Fill	15506	0.75	0.35	Secondary Fill	Iron bar frag, Bu Flint	undated
15508	Cut		0.80	0.25	Pit		
15509	Fill	15508		0.18	Secondary Fill		
15510	Fill	15508		0.25	Secondary Fill	Fc	undated
15511	Cut		1.02	0.16	Pit		
15512	Fill	15511	1.02	0.16	Secondary Fill. Light to mid grey, sandy silt		
15513	Cut		1.28	0.3	Ditch		
15514	Fill	15513	0.46	0.24	Secondary Fill. Mid grey, sandy silt		
15515	Fill	15513	0.78	0.3	Secondary Fill. Mid brown grey, sandy silt		
15516	Cut		1.32	0.4	Ditch		
15517	Fill	15516	1.32	0.4	Secondary Fill. Mid grey brown, sandy silt		
15518	Cut		1.32	0.3	Ditch		
15519	Fill	15518	1.32	0.3	Secondary Fill. Mid brown grey, sandy silt	Pot	LBA/IA
15520	Cut		1.58	0.28	Ditch		
15521	Fill	15520	0.36	0.12	Secondary Fill. Light brown grey, sandy silt		
15522	Fill	15520	1.58	0.28	Secondary Fill. Mid brown grey, sandy silt		
15523	Cut		0.56	0.36	Ditch		
15524	Fill	15523	0.52	0.18	Secondary Fill. Mid brown grey, sandy silt	Flint	LMeso
15525	Fill	15523	0.56	0.2	Secondary Fill. Light brown grey, sandy silt	Flint	
15526	Cut		0.6	0.34	Pit		

15527	Fill	15526	0.6	0.34	Secondary Fill. Dark brown grey, sandy silt		
15528	Unexcavated feature		0.95		Ditch. Fill is a light brown grey, sandy silt		
15529	Cut		0.64	0.5	Pit		
15530	Fill	15529	0.64	0.5	Secondary Fill. Light yellow grey, sandy silt		
15531	Cut		0.98	0.36	Pit		
15532	Fill	15531	0.92	0.12	Secondary Fill. Light brown grey, sandy silt		
15533	Fill	15531	0.98	0.28	Secondary Fill. Mid brown grey, sandy silt		
15534	Layer		0.72	0.12	Colluvial Layer. Mid brown grey, sandy silt		
15535	Unexcavated feature		0.73		Ditch. Fill is a light brown grey, sandy silt		
15536	Unexcavated feature		1.5		Ditch. Possibly same as [15520] Fill is a light grey brown, sandy silt		

Trench 156							
General description					Orientation		
Not excavated. Trench located under low overhead power lines.					Length (m)		
					Width (m)		
					Avg. depth (m)		
Context No.	Type	Fill Of	Width (m)	Depth (m)	Description	Finds	Date

Trench 157							
General description					Orientation		
Not excavated. Trench located under low overhead power lines.					Length (m)		
					Width (m)		
					Avg. depth (m)		
Context No.	Type	Fill Of	Width (m)	Depth (m)	Description	Finds	Date

Context No.	Type	Fill Of	Width (m)	Depth (m)	Description	Finds	Date
-------------	------	---------	-----------	-----------	-------------	-------	------

### Trench 158

General description					Orientation	N-S	
Trench devoid of archaeology. Consists of ploughsoil and subsoil overlying natural geology of clayey sand and gravel patches.					Length (m)	30	
					Width (m)	2.1	
					Avg. depth (m)	0.44	
Context No.	Type	Fill Of	Width (m)	Depth (m)	Description	Finds	Date
15800	Layer			0.3	Ploughsoil. Dark orange brown, clayey silt		
15801	Layer			0.14	Subsoil. Mid orange brown, sandy clay		
15802	Layer				Natural. Mid brown orange, clayey sand with gravel patches		

### Trench 159

General description					Orientation	E-W	
Trench revealed one ditch. Consists of ploughsoil overlying natural geology of silty sand with gravels.					Length (m)	30	
					Width (m)	2	
					Avg. depth (m)	0.3	
Context No.	Type	Fill Of	Width (m)	Depth (m)	Description	Finds	Date
15900	Layer			0.33	Ploughsoil. Dark grey brown, silty clay	Flint	
15901	Layer				Natural. Mid red yellow, silty sand and gravel patches		
15902	Cut		0.4	0.1	Ditch. Possible field boundary		

15903	Fill	15902	0.4	0.1	Secondary Fill. Firm, mid red brown, silty clay.	
-------	------	-------	-----	-----	--------------------------------------------------	--

Trench 160							
General description					Orientation		
Not excavated. Trench located under low overhead powerlines.					Length (m)		
					Width (m)		
					Avg. depth (m)		
Context No.	Type	Fill Of	Width (m)	Depth (m)	Description	Finds	Date

Trench 161							
General description					Orientation		E-W
Trench devoid of archaeology. Consists of ploughsoil and subsoil/colluvial layer overlying natural geology of clayey silt.					Length (m)		30
					Width (m)		2.1
					Avg. depth (m)		1
Context No.	Type	Fill Of	Width (m)	Depth (m)	Description	Finds	Date
16100	Layer			0.3	Ploughsoil. Dark grey brown, clayey silt.		
16101	Layer			0.5	Subsoil. Mid orange brown, clayey silt.	Pot	AD1270-1350
16102	Layer			0.2	Colluvial Layer. Mid grey brown, clayey silt.		
16103	Layer				Natural. Mid brown orange, clayey sand with gravel.		

Trench 162							
General description					Orientation		E-W
Trench devoid of archaeology. Trench consists of ploughsoil and subsoil overlying natural geology of clayey sand and gravels.					Length (m)		30
					Width (m)		2



						Avg. depth (m)	0.75
Context No.	Type	Fill Of	Width (m)	Depth (m)	Description	Finds	Date
16200	Layer			0.25	Ploughsoil. Dark grey brown, silty clay		
16201	Layer			0.5	Subsoil. Mid orangey brown, clayey sand		
16202	Layer				Natural. Mid red yellow, clayey sand and gravels		

<b>Trench 163</b>							
General description					Orientation		
Not excavated. Trench located under low overhead power lines.					Length (m)		
					Width (m)		
					Avg. depth (m)		
Context No.	Type	Fill Of	Width (m)	Depth (m)	Description	Finds	Date

<b>Trench 164</b>							
General description					Orientation		E-W
Trench revealing one pit or natural feature. Trench consists of ploughsoil and subsoil overlying natural geology of silty sand and gravels.					Length (m)		30
					Width (m)		2
					Avg. depth (m)		1
Context No.	Type	Fill Of	Width (m)	Depth (m)	Description	Finds	Date
16400	Layer			0.3	Ploughsoil. Dark grey brown, silty clay		
16401	Layer			0.7	Subsoil. Mid orangey brown, clayey sand		

16402	Layer				Natural. Mid red yellow, silty sand and gravels		
16403	Cut		1.22	0.36	Pit. Cut of pit or most likely natural feature		
16404	Fill	16403	1.22	0.16	Secondary Fill. Light orangey grey, silty sand with charcoal flecks		
16405	Fill	16403	0.56	0.04	Placed Deposit. Dark grey, charcoal lens	Pot	LBA/IA
16406	Fill	16403	1	0.18	Tertiary Fill. Light brown grey, silty sand		

Trench 165							
General description						Orientation	E-W
One ditch present. Trench consists of ploughsoil and subsoil overlying one colluvial layer. Natural geology not exposed.						Length (m)	30
						Width (m)	2
						Avg. depth (m)	1
Context No.	Type	Fill Of	Width (m)	Depth (m)	Description	Finds	Date
16500	Layer			0.27	Ploughsoil. Dark grey brown, silty clay		
16501	Layer			0.43	Subsoil. Mid orangey brown, clayey sand		
16502	Layer			0.3	Colluvial Layer. Mid yellow brown, silty sand. Over 0.30m, but max depth (1m) in trench reached		
16503	Cut		1.79	1	Ditch		
16504	Fill	16503	1.79	1	Primary Fill. Mid brown clayey silt. No finds.		

Trench 166							
General description					Orientation		NW-SE
Trench devoid of archaeology. Trench consists of ploughsoil and subsoil overlying one colluvial layer. Natural geology not exposed.					Length (m)		30
					Width (m)		2
					Avg. depth (m)		1
Context No.	Type	Fill Of	Width (m)	Depth (m)	Description	Finds	Date
16600	Layer			0.3	Ploughsoil. Dark grey brown, silty clay		
16601	Layer			0.45	Subsoil. Light orangey brown, clayey sand		
16602	Layer			0.25	Colluvial Layer. Mid yellowish brown, silty sand. Over 0.25m, but max depth (1m) in trench reached		

Trench 167							
General description					Orientation		NW-SE
Trench devoid of archaeology. Trench consists of ploughsoil and subsoil overlying one colluvial layer and natural geology of silty sand.					Length (m)		30
					Width (m)		2
					Avg. depth (m)		1
Context No.	Type	Fill Of	Width (m)	Depth (m)	Description	Finds	Date
16700	Layer			0.25	Ploughsoil. Dark greyish brown, silty clay		
16701	Layer			0.35	Subsoil. Mid orangish brown, silty clay		
16702	Layer			0.41	Colluvial Layer. Mid greyish brown, silty sand		

16703	Layer				Natural. Light yellowish brown with mid 9 brown patches, silty sand	
-------	-------	--	--	--	---------------------------------------------------------------------	--

Trench 168							
General description					Orientation	NE-SW	
Trench devoid of archaeology. Trench consists of ploughsoil overlying two colluvial layers. Natural not exposed.					Length (m)	30	
					Width (m)	2	
					Avg. depth (m)	1	
Context No.	Type	Fill Of	Width (m)	Depth (m)	Description	Finds	Date
16800	Layer			0.37	Ploughsoil. Dark greyish brown, silty clay		
16801	Layer			0.24	Colluvial Layer. Mid greyish brown, silty clay		
16802	Layer			0.35	Colluvial Layer. Mid yellowish brown, silty sand. Only present in SW end		

### B.1 Prehistoric pottery

By Alex Davies

#### Introduction

- B.1.1 Some 576 sherds (6099g) of prehistoric pottery from 28 contexts across 21 trenches were recovered from the evaluation (Table 1). Three distinct periods were represented: the late Neolithic/early Bronze Age (Beaker; c 2450-1850 cal BC), the middle Bronze Age (c 1600-1150 cal BC), and the late Bronze Age/Iron Age (c 1150-50 cal BC). The majority of this last group should belong within the earlier part of the span.
- B.1.2 The mean sherd weight (MSW) of 10.6g appears reasonably high for prehistoric assemblages, but a single large context (Ditch Fill 13915) skews this figure. When the material from this context is removed, the MSW drops to 4.9g. This indicates that the assemblage is in a variable condition.
- B.1.3 This section does not consider late Iron Age material. Any late Iron Age pottery is dealt with alongside the Roman material, below.

#### Late Neolithic/early Bronze Age

- B.1.4 Two contexts in Trench 47 produced a total of 31 small sherds (75g) from Beakers. At least two Beakers are represented, one with combed decoration and another with incised decoration. The vessel with combed decoration is in a fine sandy fabric, and the Beaker with incised decoration is in a fine sand and flint fabric.

#### Middle Bronze Age to Iron Age

- B.1.5 Despite the assemblage being quite large for an evaluation with a number of sizable groups, there are very few diagnostic sherds. Almost all of the middle Bronze Age to Iron Age vessels are represented by body sherds. Dating therefore has to rely largely on fabric, with a few other indicative elements such as wall thickness, decoration and features such as cordons.
- B.1.6 Fabrics can be compared with nearby later prehistoric assemblages at Mucking (Barrett 1988; Brown 2016; Brudenell 2016a; 2016b) and Orsett Cock (Brown 1998). Flint was the dominant local fabric during the middle and late Bronze Age, being steadily replaced with quartz sand through the Iron Age. Flint still remained popular well into the middle Iron Age, with sand only becoming dominant around the second century BC (Brudenell 2016b, 380).
- B.1.7 Body sherds are difficult to date due to this long-term use of flint as a tempering agent, but other elements can be used to assist in spot-dating. In the middle Bronze Age there was a clear distinction between the common coarse thick-walled (> c 10mm) vessels, and rare very fine thin-walled pots. The distinction between coarse and fine wares continued into the late Bronze Age and early Iron Age although became less marked with coarse wares tending to have finer fabrics and thinner walls compared to their middle Bronze Age predecessors.
- B.1.8 All but two of the later prehistoric vessels are in flint-dominated fabrics. The majority of these are in moderately coarse fabrics with walls of medium thickness. This

suggests that the focus of the assemblage is late Bronze Age or Iron Age, rather than middle Bronze Age. The rarity of fabrics comprising only quartz sand (found only in fill 15304 of ditch 15303, in Trench 153 and colluvial layer 6804 in Trench 68 – the latter just two sherds found alongside 220 sherds of a vessel in a flint fabric) suggests that there is little if any middle Iron Age presence, with much of the material dating to the late Bronze Age and/or early Iron Age, c 1150-350 cal BC.

B.1.9 Diagnostic middle Bronze Age material was present in subsoil 4101 (Trench 41), fill 13915 of ditch 13914 and fill 13918 of ditch 13916, both Trench 139. Decorated material from context 4101 comprises a cordon with fingernail decoration. Diagnostic material from context 13915 comprises much of a plain freshly broken bucket 'urn' without a cordon with a rim diameter of c 40cm, including sherds from the rim and base. It is likely that much of the vessel could be refitted. Diagnostic material from context 13918 comprises another bucket 'urn' decorated with slashes on the top of the rim. Carbonised residue from cooking is preserved on its inner and outer surfaces. Subsoil 4101 and fill 11907 of ditch 11906 in Trench 119, produced possible middle Bronze Age material. Pottery from fill 11907 comprised a straight-sided probably tub-shaped vessel dating to the middle or late Bronze Age.

<i>Context</i>	<i>Sherds</i>	<i>Weight</i>	<i>Spot-date</i>	<i>Date (BC)</i>	<i>Fabric</i>	<i>Comment</i>	<i>Sample</i>
1712	8	14	LBA/IA	1150-50	Flint		Inc. 13
3403	5	4	LBA/IA	1150-50	Flint		3
4101	66	242	MBA-EIA	1600-350	Flint (coarse)	sf. 100	
4108	1	39	MBA	1600-1150	Flint (coarse)	Cordon with fingernail decoration.	
4705	1	2	L Neo/EBA (Beaker)	2450-1850	Sand	Comb decorated	15
4708	30	73	L Neo/EBA (Beaker)	2450-1850	Sand, flint (fine)	Incised decoration	Inc. 16
6102	6	10	LBA/IA	1150-50	Flint		
6405	7	30	LBA/IA	1150-50	Flint		
6406	1	3	LBA/IA	1150-50	Flint		
6804	222	1233	LBA/IA	1150-50	Flint; Sand	Mainly one fragmented pot with flint temper with no form, but one sandy rim. Also fired clay	Inc. 1
6904	8	3	LBA/IA	1150-50	Flint		
9403	31	123	LBA/IA	1150-50	Flint		Inc. 3
11106	1	5	LBA/IA	1150-50	Flint, sand		9
11907	6	57	MBA/LBA	1600-800	Flint	Straight-sided	
12202	6	40	LBA/IA	1150-50	Flint		

12301	1	3	LBA/IA	1150-50	Flint		
13107	2	7	LBA/IA	1150-50	Flint		
13405	1	6	LBA/IA	1150-50	Flint		
13604	8	20	LBA/EIA	1150-350	Flint (coarse)	Quite thin walled despite being coarse	
13608	3	5	LBA/IA	1150-50	Flint, sand		
13905	1	2	LBA/IA	1150-50	Flint		
13915	150	4018	MBA	1600-1150	Flint (coarse)	Much of a freshly broken MBA bucket 'urn'.	
13918	4	128	MBA	1600-1150	Flint (coarse)	Bucket 'urn'. Slashes on rim top. Carbonised residue.	
15203	1	6	LBA/IA	1150-50	Flint		
15304	2	5	IA	800-50	Sand		18
15306	1	11	LBA/IA	1150-50	Flint		
15519	1	2	LBA/IA	1150-50	Flint		
16405	2	8	LBA/IA	1150-50	Flint, sand		
<b>TOTAL</b>	<b>576</b>	<b>6099</b>					

Table B.1.1: Summary of the prehistoric pottery

## B.2 Late Iron Age and Roman Pottery

By Kate Brady

### Introduction

B.2.1 Five sherds of late Iron Age and Roman pottery, weighing 16g, were recovered from the evaluation. The assemblage was scanned to identify diagnostic forms and fabrics, provide spot-dates and generally characterise the material. The assemblage was also assessed in terms of its conservation, discard and retention. Later Iron Age and Roman pottery fabrics were assigned codes from OA's standard recording system for material of that date (Booth 2016). Forms identified by rim were given codes from OA's recording system.

B.2.2 Each context-group was quantified by sherd count and weight (grammes), and any rims present were additionally quantified by estimated vessel equivalents (EVEs), which measures the percentage of rim circumference that survives (thus, 0.3 equals 30%). Pottery data by context is provided in Table 1.

B.2.3 The following late Iron Age and Roman fabrics were noted:

- O10 Fine sandy reduced ware
- O20 Sandy oxidised ware
- R20 Sandy reduced ware
- R40 Miscellaneous reduced ware

B.2.4 The following forms identified by rim were recorded:

- D Indeterminate jar/bowl

### Description

Context	Count	Weight	MV	EVE	Comments
15304	1	2	0	0	Sandy oxidised ware O20
15204	1	3	0	0	R40 micaceous reduced ware
6407	1	7	1	0.05	R20 reduced sandy reduced ware everted rim of jar or bowl (D)
2405	1	1	0	0	Sandy oxidised ware O20
4706	1	3	0	0	Fine sandy oxidised ware

Table B.2.1: Summary and quantification of the pottery by context (Key: EVE estimated vessel equivalent; MV minimum number of vessels).

B.2.5 **Roman.** This very small assemblage consisted of sherds of sandy reduced and oxidised ware of probable local origin. Only a single rim sherd was recovered, and this was from a jar or bowl with an everted rim. None of the sherds could be dated more closely than to the Roman period (AD 40-410).



## B.3 Medieval Pottery

By John Cotter

### Introduction and methodology

- B.3.1 A total of six sherds of medieval and post-medieval pottery weighing 93g were recovered from four contexts. Ordinary domestic wares were recovered. Given the small amount this has not been separately catalogued but is fully described below.
- B.3.2 The context spot-date is the date-bracket during which the latest pottery types or fabrics are estimated to have been produced or were in general circulation. Comments on the range of fabrics were recorded, usually with mention of vessel form (jugs, bowls etc.) and any other attributes worthy of note (e.g. decoration etc.). Fabric codes referred to are those of the Museum of London (MOLA 2014).

### Description

- B.3.3 **Context 2605 (Fill of Pit 2604) Spot-date: c 1100-1250.** Description: 2 sherds (weight 23g). A cooking pot rim and a body sherd in Essex-type shelly-sandy ware (Fabric code: SSWX). Both in fairly fresh condition. These have a fine sandy to silty fabric with some fine mica and moderate coarse platy voids where the shell inclusions have dissolved-out. The cooking pot is in a reduced grey fabric with a soot-blackened external surface. It has a thickened flat-topped rim with a sub-squared external lip and has an incised line on the inside behind the rim. The body sherd has an orange-brown oxidised core with a grey-brown external surface and a reduced grey internal surface.
- B.3.4 **Context 2607 (Fill of Pit 2606) Spot-date: c 1140-1220.** Description: 2 sherds (weight 37g). Fresh joining rim sherds from a cooking pot in London shelly-sandy ware (Fabric code: SSW). Fairly coarse sandy fabric with abundant rounded quartz, sparse flint and sparse shell inclusions - mostly dissolved-out. Some organic inclusions. Weakly oxidised orange-brown surfaces with a grey core. Curved, flaring, everted neck with small triangular rim. The internal angle of the rim is decorated with a continuous row of thumb impressions. Body and rim tip sooted externally from use.
- B.3.5 **Context 14700 (Ploughsoil) Spot-date: c 1830-1900.** Description: 1 sherd (weight 8g). Body sherd from the flanged rim of a dish in Staffordshire-type transfer-printed ware (Fabric code: TPW). Traces of blue-grey border decoration in a European/Classical style on the inside.
- B.3.6 **Context 16101 (Subsoil) Spot-date: c 1270-1350.** Description: 1 sherd (weight 25g). Body sherd from the neck of a jug in Mill Green ware (Fabric code: MG). Fairly fine sandy brick-red fabric with a grey core. From the cylindrical neck of a jug with anthropomorphic decoration - part of a human face with an eye. The entire neck appears to be covered with a thick white slip through which the details have been deeply incised sgraffito-fashion down into the red fabric underneath. From the viewer's point of view - only the top left part of the face survives with a complete lentoid-shaped (or sideways pear-shaped) eye, with a central stabbed pit for the pupil. The eye measures about 25mm across and the face would have been quite large for an anthropomorphic jug. To the left of the eye there is an incised and roughened area which might be part of an eyebrow, or part of the hairline? Part of the cheek below

the eye survives, but no other details. Looking vertically down on the sherd one can see that the neck has been pushed-out from within behind the face suggesting it may have been at the base of a large pulled-out pouring-lip or spout. The face is covered with a thin clear glaze with light copper-green patches. The maximum length of the sherd is 61mm. A Mill Green ware jug from London, with a large (though damaged) face is illustrated in the published corpus of this ware (Pearce et al 1982, Fig. 8.16), and miniature jugs with similar incised eyes are also illustrated there (ibid., Fig. 9.17-18).

## B.4 Flint

By Michael Donnelly

### Introduction

- B.4.1 Some 576 sherds (6099g) of prehistoric pottery from 28 contexts across 21 trenches were The struck flint was widely dispersed across the evaluation area generally in quite low numbers, but one Beaker-period pit 4703, Trench 47, yielded 46 flints. The assemblage was largely flake-based but despite this a number of diagnostic early prehistoric flints, including a burin, end truncation and a pair of late Mesolithic microliths were recovered as stray finds in later contexts. This indicates a limited early prehistoric presence here, as well, with the potential for denser flint-rich contexts as well as possible additional pits to be encountered, should any further works commence.

Table B.4.1:

CATEGORY TYPE	Number
Flake	61
Blade	3
Bladelet	2
Blade index	7.58% (5/66)
Irregular waste	7
Sieved chip 10-2mm	11
Core tablet	1
Core multi-platform flakes	3
Scraper end	3
Scraper side	2
Scraper side & end	3
Scraper thumbnail	1
Microlith	2
Burin	1
End truncation	1
Piercer	2
Microdenticulate	1
Backed knife	2
Retouched flake	4
Retouched other	2
Retouched miscellaneous	1
<b>Total</b>	<b>113</b>
Burnt unworked	725/3456g
No. burnt (%)	10/113 (8.85%)

No. broken (%)	29/102 (28.43%)
No. retouched (%)	25/102 (24.51%)

### Provenance (Table 2)

B.4.2 The largest component of the assemblage was recovered from pit fills (46.02%), nearly all of which was from a single pit (4703). Topsoil finds accounted for the second largest fraction (also including two subsoil finds) with 34.51%, followed by ditch fills (10.62%) and lesser numbers from colluvium (3.54%), tree throw fills (2.65%), and from the natural (2.65%).

Table B.4.2: The flint assemblage by context type

CATEGORY TYPE	Total	Percentage
Pits	52	46.02
Topsoil/subsoil	39	34.51
Ditches	12	10.62
Colluvium	4	3.54
Natural	3	2.65
Treethrows	3	2.65
Total	113	[100]

B.4.3 The topsoil material showed some marked concentrations. However, it is not clear if this pattern is real, or simply a product of various degrees of skill in spotting flints from the excavators. For example, trench 155 had 11 topsoil/subsoil finds but just two flints from numerous features identified in that trench, whereas Trench 47 had no topsoil finds and 46 flints from its features.

B.4.4 Burnt unworked material was almost wholly recovered from samples and included sizeable assemblages from pit 9505, fill 9507, Trench 95 (125 fragments/1735g) and pit 11802, fills 11804-5, Trench 118 (468 fragments/938g). In most instances the burnt unworked material was found in features that lacked struck flint indicating a very different use of flint presumably in later prehistoric and early historic periods.

### Raw material and condition

B.4.5 Flint was the sole material represented here and came with a variety of cortical states indicating that a range of sources was exploited. However, the assemblage was dominated by thin abraded cortex typical of some North Downs material (68.97%, 40/58). This was followed by more typical chalk cortex found on 10 examples (17.24%), six of which were heavily weathered indicating a secondary source. Bullhead Bed material (Dewey and Bromehead 1915) accounted for just two examples (3.45%), as did rolled/gravel cortex and there were four with thermal surfaces (6.89%).

B.4.6 The flints were either lightly edge-damaged (39/91, 42.86%) or fresh (29/91, 31.87%), with 18 pieces displaying moderate (19.78%), three with heavy edge damage (3.30%) and two that were clearly plough damaged (2.20%).

B.4.7 Cortication was largely light (75/91, 82.42%) with lessor amounts displaying moderate (10/91, 10.98%) or no cortication (6/91, 6.59 %). Overall, the condition of the material suggests an assemblage that includes lightly disturbed pieces alongside a limited number of in situ assemblages from contemporary, key features such as the Beaker pit 4703.

### Discussion

B.4.8 The assemblage included diagnostic elements from early prehistory alongside a very secure assemblage of late Neolithic-early Bronze Age date from Beaker pit 4703, Trench 47. The bulk of the undiagnostic debitage would appear to belong to periods after the earlier Neolithic. All core forms were exclusively geared towards flake production and the assemblage as a whole had a very low blade index of just 7.58% (Ford 1987).

B.4.9 Beaker pit group 4703 contained the key assemblage identified during the evaluation and comprised flints from all four of its fills (Table 3). The four fills alternated between relatively sterile layers and finds-rich layers that also contained the Beaker pottery sherds. The fills display levels of breakage (39.47% vs 21.88%) and burning (19.57% vs 1.75%) that are far higher than in the remainder of the assemblage, indicating some degree of selectivity as regards what made its way into the pit and suggesting some form of structure to these depositional practices. Tools were common, but actually less so than the probably selectively recovered collection of residual material that made up the remainder of the assemblage (13.16% vs 31.25%). The potential for further pits of this period should further works commence must be considered, but it is worth mentioning that Beaker pits can often be found in relative isolation.

Table B.4.3 Flint from selected contexts

CATEGORY TYPE	Fill 4704	Fill 4705	Fill 4706	Fill 4708	Total
Flake	1	12	3	11	27
Bladelet		1			1
Blade index	0%	7.69% (1/13)	0%	0%	3.57% (1/28)
Irregular waste		3		2	5
Sieved chip 10-2mm		6		2	8
Scraper end		1			1
Scraper side		1		1	2
Scraper side & end				1	1
Retouched flake				1	1
Total	1	24	3	18	46
Burnt unworked	0	2 / 5g	0	1 / 1g	3 / 6g
No. burnt (%)	0	29.17% (7/24)	0	11.11% (2/18)	19.57% (9/46)
No. broken (%)	0	50% (9/18)	0	37.5% (6/16)	39.47% (15/38)

No. retouched (%)	0	11.11% (2/18)	0	18.75% (3/16)	13.16% (5/38)
-------------------	---	------------------	---	------------------	------------------

- B.4.10 A number of early prehistoric finds were recovered, including a (probably) unfinished rod microlith from ditch 15523, fill 15524, Trench 15, and a backed bladelet microlith from colluvium 6405, Trench 64. Both microliths belonged to the late Mesolithic period with rod forms generally being viewed as very late in date (Griffiths 2014). Additionally, several other early finds of less precise date were recovered, including: a probable thick heavy dihedral burin from tree throw 10710, fill 10712, Trench 107; an end truncation on a blade from topsoil 8900, Trench 89; a backed blade used as a knife from topsoil 12700, Trench 127; and a core tablet found in the natural 15302 in Trench 153. One thumbnail scraper from topsoil 12300, Trench 123, could equally belong to either the late Mesolithic or late Neolithic-early bronze Age as it is of a slightly irregular form sometimes found in late Mesolithic assemblages but could equally be a slightly atypical Beaker find.
- B.4.11 The majority of the remainder of the assemblage is more typical of industries dating from after the early Neolithic including Beaker period activity. The flakes from pit 4703, Trench 47, are actually quite squat in form and are often hard-hammer struck, forms that are often viewed as typifying mid-late Bronze Age activity but here are clearly earlier in date. This could imply that the relatively squat flake debitage found in many later contexts could simply be disturbed material from possible Beaker horizons (presumably middens/occupation layers that have now been truncated away). However, it is equally probable that they could represent a far more limited use of flint during the later prehistoric periods represented by much of the cut-feature activity found in this evaluation.
- B.4.12 Any further works in this area should expect to recover additional flintwork with a high likelihood of identifying additional pit assemblages and with a much lower potential for *in situ* early prehistoric activity particularly where buried by colluvial horizons.

## Methodology

- B.4.13 The artefacts were catalogued according to OA South's standard system of broad artefact/debitage type (Anderson-Whymark 2013; Bradley 1999), general condition noted and dating was attempted where possible. The assemblage was catalogued directly onto an Open Office spreadsheet. During the assessment additional information on condition (rolled, abraded, fresh and degree of cortication), and state of the artefact (burnt, broken, or visibly utilised) was also recorded. Retouched pieces were classified according to standard morphological descriptions (e.g. Bamford 1985, 72-77; Healy 1988, 48-9; Bradley 1999). Technological attribute analysis was initially undertaken and included the recording of butt and termination type (Inizan *et al.* 1999), flake type (Harding 1990), hammer mode (Onhuma and Bergman 1982), and the presence of platform edge abrasion.

## B.5 Fired Clay

By Cynthia Poole

### Introduction

B.5.1 A small quantity of fired clay amounting to 67 fragments weighing 227g was recovered from trenches 26, 47 and 155. The assemblage consists of small, poorly preserved abraded fired clay with a very low mean fragment weight of 4g. The fired clay cannot be dated and is reliant on associated dateable material for its phasing. The assemblage has been recorded on an Excel spreadsheet in accordance with guidelines set out by the Archaeological Ceramic Building Materials Group (ACBMG 2007), which whilst not specifically for fired clay, provide appropriate guidance. Fabrics were characterised on the basis of macroscopic features supplemented by the use of x20 hand lens for finer constituents.

### Description

B.5.2 The fired clay was made in two fabrics. One was a soft fine sandy / silty clay with red ferruginous mottles and fairly soft and powdery, fired to red, pink, light brown and grey. This occurred in the fills 4705 and 4708 of pit 4703, Trench 47. The other was a coarser sandy fabric containing a scatter of coarse quartz sand and flint grit 1-3mm and fired to pinkish red, buff, light grey and black. Both fabrics are probably derived from local Tertiary clay deposits in the vicinity of the site.

B.5.3 The majority of pieces were amorphous and of indeterminate form, though likely to derive from oven or hearth structure. The small fragment from fill 2605 of medieval pit 2604 in Trench 26 may be a fragment of portable oven or hearth furniture: it had two flat even moulded surfaces, forming the surface and edge of an object, such as a plate or firebar. It was well fired to black throughout and may have been used in a kiln.

Context	Sample No	Nos	Wt g	Form	Comments
2605	~	1	15	Oven/hearth furniture?	Flat surface and edge
4705	<15>	3	12	Indeterminate	Amorphous
4708	<16>	42	198	Indeterminate	Amorphous
15510	~	21	52	Indeterminate	Amorphous

Table B.5.1: Summary of fired clay assemblage

### Conclusion

B.5.4 The quantities of fired clay are sparse and do not indicate a focus of activities that result in the generation and deposition of fired clay. This assemblage does point to the presence some oven, heath or kiln structures in the area.

## B.6 Ceramic Building Material

By Cynthia Poole

### Introduction

B.6.1 A small quantity of ceramic building material (CBM) amounting to seven fragments weighing 335g was recovered from ditch fills in trenches 21, 86, 95 and 98. The material is all of post-medieval date. The material is fragmentary and relatively poorly preserved with moderate abrasion. The assemblage has been fully recorded on an Excel spreadsheet in accordance with guidelines set out by the Archaeological Ceramic Building Materials Group (ACBMG 2007) and is summarised in the table below. Fabrics were characterised on the basis of macroscopic features supplemented by the use of x20 hand lens or binocular microscope at x25 for finer constituents.

### Post-Roman CBM

B.6.2 Post-medieval flat roof tile was found in fill 2104 of ditch 2103 in Trench 21, comprising a corner fragment and a piece with a circular peg hole 14mm in diameter. They were made in an orange, fine sandy clay with red ferruginous inclusions and rare flint grit <9mm. They cannot be closely dated and the two may not be of the same date but are probably broadly 16th-18th century. The remaining pieces were all brick comprising small broken scraps made in a red fine sandy clay containing medium-coarse quartz sand and red ferruginous clay pellets up to 10mm from fill 8603 of ditch 8602 in Trench 86 and fill 9504 of ditch 9503 in Trench 95 and a single better preserved fragment from fill 9807 of ditch 9806 in Trench 98. This had a neat finish and a complete thickness of 52mm surviving and was made in fine sandy clay containing sparse shell/chalk inclusions and numerous voids possibly resulting from leached calcareous material. It had an orange-red surface, cerise margin and purplish/mauve core, colouring which may indicate the use of salt marsh clays. The thickness suggests a Tudor – Stuart date for it.

Context	Spot date	Nos	Wt g	Form	Comments
2104	C16-C18	2	97	Roof: peg	Corner fragment and fragment with peg hole 14mm dia. Thickness: 12, 17mm.
8603	Postmed	3	12	Brick	Broken scraps
9503	Postmed	1	5	Brick	Amorphous
9807	LC15-EC17	1	221	Brick	52mm th

Table B.6.1: Summary of CBM assemblage

### Conclusions

B.6.3 The assemblage is small and the material fragmentary. The bricks occur broadly in the southern central area of the site, but there is no strong reason to suppose they represent any related activity. The roof tile occurred on the west and is unrelated to the brick. The CBM appears to represent casual loss, most probably related to



agricultural activity and possibly originated from Brook Farm that lies on the northern edge of the site.

## B.7 Metals

By Ian R Scott

- B.7.1 There are six metal finds, all of iron or cast iron.
- B.7.2 From fill 2004 of ditch 2003 in Trench 20, there is a quite thick iron plate of trapezoid shape with three nail or rivet holes towards one end. The function of the plate is unclear. It is probably from a waggon, or from a piece of farm machinery. The second find from the same context is large cast iron plough share, probably of 20th-century rather than 19th-century date.
- B.7.3 The finds from fill 5404, of pit 5403 in Trench 54 comprise a small corroded piece of iron sheet, which cannot be closely dated, and a nail with a regular flat circular head. Although quite badly corroded the latter is quite clearly a drawn wire rather than a hand wrought nail, and probably recent in date.
- B.7.4 The single iron object from fill 9107 of ditch 9106 in Trench 91 is a complete iron batten ring probably of 18th-century date.
- B.7.5 The only find from fill 15507 of pit 15506 is a small piece of iron bar which is not closely datable.

**Table B.7.1: Finds Register – metal finds**

Context 2004	(1)	Trapezoid plate with three drilled holes at its square end. The opposite end is angled at c 45 degrees. The shorter long side is thicker and bevelled, and the longer edge is thin, eroded and irregular in outline. 145mm x 74mm; Th: 7mm.
	(2)	Plough share, cast iron. L: 265mm; Ht: 200mm; W: 75mm. 91th-century or later, most probably 20th-century.
Context 5404	(3)	Thin sheet iron, irregular eroded fragment. 105mm x 39mm.
	(4)	Drawn wire wood nail with flat circular head. Fe. L: 110mm. Modern.
Context 9107	(5)	Iron patten ring with oval hoop and low terminals. The front terminal has a single rivet and extended tongue and the rear terminal has two rivets. The ring would have been attached to a wooden patten. The patten and ring would have been worn over shoes. L: 225mm; Ring 145mm x 90mm. Post medieval, probably 18th-century.
Context 15507	(6)	Bar, small fragment. Fe. L: 30mm.

## B.8 Worked Stone

By Ruth Shaffrey

- B.7.6 A single piece of stone was retained from upper fill 4708 of Beaker pit 4703 in Trench 47. This is a small fragment of ferruginous sandstone weighing 51g. It has a possible worked surface and could be part of a quern but is too small for this function to be confidently assigned.
- B.7.7 The fragment should be retained so that if more certain quern fragments are found nearby, it can be compared to them.

### C.1 Environmental Samples

By Richard Palmer

#### Introduction

- C.1.1 Twenty-two samples were taken from the evaluation, primarily for the retrieval and assessment of charred plant remains (CPR) and the recovery of bones and artefacts.

#### Method

- C.1.2 The samples were processed in their entirety at Oxford Archaeology using a modified Siraf-type water flotation machine. The flots were collected in a 250µm mesh and heavy residues in a 500µm mesh and dried. The residue fractions were sorted by eye and with the aid of a magnet, while the flot material was sorted using a low power (x10) binocular microscope to extract cereal grains and chaff, smaller seeds and other quantifiable remains.

#### Results

- C.1.3 A summary of the samples and flot assessment is presented in Table 1.
- C.1.4 **Trench 17.** Sample 13 is from fill 1712 of ditch 1709 and is spot-dated as late Bronze Age/iron Age. A small quantity of charcoal was recovered in relatively good condition with some surface vitrification. Clinker-like charred material was also recovered. Several hazelnut fragments (*Corylus avellana*) were identified along with speedwell (*Veronica* sp.) and goosefoot (*Chenopodium* sp.) seeds. Burnt flint, pottery and further clinkered like material was recovered from the residue.
- C.1.5 **Trench 25.** Sample 12 is from fill 2505 of tree throw 2503. A large quantity of charcoal was recovered in good condition along with a quantity of clinker-like material. Goosefoot seeds (*Chenopodium* sp.) were present but all checked examples were modern so the majority are assumed to be such and have not been quantified. A small legume was also identified. Some flint was recovered from the residue.
- C.1.6 **Trench 47.** Sample 14 is from fill 4704 of pit 4703. A large quantity of charcoal was recovered and there is potential for further identification work.
- C.1.7 Sample 15 is from fill 4705 of pit 4703 and is spot-dated as late Neolithic/early Bronze Age. Several hundred fragments of charcoal >2mm in size were recovered from the sample, some of which are ring porous. Flint, pottery and fired clay were recovered from the residue.
- C.1.8 Sample 16 is from fill 4708 of pit 4703 and is spot-dated as late Neolithic/early Bronze Age. A large quantity of potentially identifiable charcoal was recovered. Surface staining on charcoal does not appear to extend to internal structure, so further identification should be possible. Small quantities of pottery and flint were recovered along with a larger assemblage of fired clay.

- C.1.9 **Trench 54.** Sample 17 is from fill 5304 of pit 5403 which is suspected to be modern. Charcoal and clinker-like material was recovered along with goosefoots (*Chenopodium* sp.) most of which appear to be modern.
- C.1.10 **Trench 68.** Sample 1 is from colluvial layer 6804 and is spot-dated as late Bronze Age/iron Age. A small quantity of charcoal in fair condition and some goosefoot seeds (*Chenopodium* sp.) were recovered. Pottery and burnt flint were extracted from the residue.
- C.1.11 **Trench 78.** Sample 4 is from fill 7806 of tree throw 7805. Charcoal was recovered in good condition though some fragments have at least one plane <2mm. Two hazelnut fragments (*Corylus avellana*) were identified. No material was recovered from the residue.
- C.1.12 **Trench 94.** Sample 3 is from fill 9403 of pit 9402 which is dated as late Bronze Age/iron Age. Recovered charcoal is in good condition. A small quantity of heavily damaged and vitrified grain is present, but further identification is hindered by the condition of the material. Speedwell (*Veronica* sp.) seeds and a legume were also identified. Pottery was recovered from the residue as was cremated human bone.
- C.1.13 **Trench 95.** Sample 8 is from fill 9507 of pit 9505. The flot is mostly charcoal with approximately 100+ fragments >4mm in size. Preservation is very good with some fragile material surviving. Some of the charcoal is ring porous. Goosefoot (*Chenopodium* sp.) seeds are also present. Burnt flint in large quantities is present in the residue.
- C.1.14 **Trench 107.** Sample 7 is from fill 10716 of pit 10715. A large quantity of charcoal in good condition makes up the bulk of the flot. Speedwell (*Veronica* sp.) and goosefoot (*Chenopodium* sp.) seeds were identified. Burnt flint was recovered from the residue.
- C.1.15 **Trench 111.** Sample 9 is from fill 11106 of pit/tree throw 11105 and is spot dated as late Bronze Age/iron Age. The burrowing snail *Cecilioides acicula* was found to be present in the flot but has not been quantified. Recovered charcoal was in good condition. Speedwell (*Veronica* sp.), goosefoot (*Chenopodium* sp.) and a small (1mm) legume (Fabaceae) were also identified. Burnt and worked flint along with pottery were recovered from the residue.
- C.1.16 **Trench 113.** Sample 6 is from fill 11304 of natural feature 11303. No charred material >4mm was recovered. Burnt flint was recovered from the residue.
- C.1.17 **Trench 115.** Sample 5 is from fill 11505 of tree throw 11504. A small quantity of charcoal was recovered. Speedwell (*Veronica* sp.), goosefoot (*Chenopodium* sp.) and a small legume were identified. Burnt stone was recovered from the residue.
- C.1.18 **Trench 118.** Sample 10 is from fill 11804 of pit 11802. No material >4mm was recovered. A single damaged grain is present but could not be further identified. A legume and a few speedwell (*Veronica* sp.) seeds were identified. A large quantity of goosefoot (*Chenopodium* sp.) seeds are present and quantified. However, several of the checked specimens were modern so actual quantity of charred specimens is unknown. Burnt flint and burnt stone were recovered from the residue.

- C.1.19 Sample 11 is from fill 11806 of ditch 11805. Apart from six charcoal fragments >2mm all other material in the flot is modern. Burnt flint was recovered from the residue.
- C.1.20 **Trench 139.** Sample 19 is from fill 13918 of ditch 13916 and is dated as middle Bronze Age. Barley (*Hordeum vulgare*) grain makes up almost the entire assemblage apart from dock (*Rumex* sp.). Condition of the barley ranges from fair for intact specimens to poor and heavily damaged with many items fragmented. It is estimated that several hundred grains are present and there is the potential that some is six-row barley. This sample warrants further assessment in the event of further work at the site. No artefacts were recovered from the residue.
- C.1.21 **Trench 153.** Sample 18 is from fill 15304 of ditch 15303. Little in the way of material is present with the weed assemblage primarily being goosefoot (*Chenopodium* sp.). Pottery and iron were recovered from the residue.
- C.1.22 **Trench 155.** Sample 20 is from fill 15504 of pit 15503. A small quantity of charred material, charcoal and goosefoot (*Chenopodium* sp.) seeds were recovered. A large quantity of burnt flint was recovered from the residue.
- C.1.23 Sample 21 is from fill 15505 of pit 15503. A small quantity of charcoal and a few weed seeds were recovered. A large quantity of burnt flint was recovered from the residue.
- C.1.24 Sample 22 is from fill 15507 of pit 15506. Charred material is limited to charcoal and all identifiable weed seeds are uncharred/modern. Burnt flint was extracted from the residue.
- C.1.25 **Trench 164.** Sample 23 is from fill 16405 of pit 16403 and is spot dated as late Bronze Age/iron Age. Recovered charcoal often has one or more planes <2mm reducing its utility. A single wheat grain (*Triticum* sp.) was identified. No finds were recovered.

## Discussion

- C.1.26 The samples indicate good potential for the recovery of charred material and preservation of material usually ranges from fair to good. Few features have been dated and this hinders interpretation of recovered material.
- C.1.27 Recovered material does offer some insights into subsistence as both hazelnut and goosefoots such as fat hen (*Chenopodium album*) were utilised as food resources during the Neolithic and use could have continued into the later prehistoric periods. We also have evidence of barley being cultivated in the Bronze Age and evidence for cultivation of cereals continues into the Iron Age. This presents an opportunity to investigate changing subsistence practices from the end of the Neolithic through to the Iron Age.

### *Late Neolithic/early Bronze Age*

- C.1.28 Two samples are of this date, and both are from pit 4703. Samples are charcoal rich offering good potential for species identification and interpretation of wood use for this period.

### *Middle Bronze Age*

C.1.29 A single sample is dated to this period. Sample 19 produced a significant quantity of barley *Hordeum vulgare* and should be considered for further assessment and possible analysis. It may be possible to further identify the barley as 2-row or 6-row. There may also be potential to investigate cereal processing.

*Late Bronze Age/Iron Age*

C.1.30 Five samples date to this period but recovered material has limited interpretive value. Grain was recovered from Sample 3 but its poor condition hinders further identification and interpretation.

*Undated*

C.1.31 Most samples are currently undated limiting the potential scope for interpretation. Several samples have small quantities of hazelnut *Corylus avellana* offering potential for radiocarbon dating. Samples 7 and 8 also contain quantities of identifiable charcoal so these samples could also be considered for radiocarbon dating and further analysis of the charcoal.

Sample no.	Context no.	Trench	Feature/Deposit	Date	Sample vol. (L)	Flot vol. (ml)	Charcoal >2mm	Grain	Chaff	Weeds	Molluscs	Other	Notes
1	6804	68	6804	LBA/IA	40	20	++			+			10YR 4/2 silty sand. Moderate modern roots.
3	9403	94	9402	LBA/IA	10	25	++	++		+		+	10YR 2/1 sand. Frequent modern roots.
4	7806	78	7805		4	36	+++					+	10YR 5/6 loamy sand. Some modern roots.
5	1150 5	115	1150 4		10	38	+++			++		+	10YR 5/3 sand. Some modern roots.
6	1130 4	113	1130 3		8	20	++						10YR 3/2 sandy silt loam. Mostly modern roots. No material >4mm.
7	1071 6	107	1071 5		10	50	+++ +			+			10YR 5/6 sandy loam. Modern

													roots present.
8	9507	95	9505		20	140	+++ +			++			10YR 2/1 loamy sand. Some modern roots.
9	1110 6	111	1110 5	LBA/IA	20	60	+++			++			10YR 4/2 sandy silt loam. Some modern roots.
10	1180 4	118	1180 2		20	20	++	+		+++		+	10YR 4/4 sandy loam. Mostly modern roots.
11	1180 6	118	1180 5		40	60	++						10YR 5/3 loamy sand. Majority of flot material is modern.
12	2505	25	2503		10	55	+++ +			+		+	10YR 4/6 sandy loam.
13	1712	17	1709	LBA/IA	20	12	++			++		++	10YR 4/6 sandy loam. Some modern roots.
14	4704	47	4703		7	125	+++ +						7.5YR 4/3 sandy silt loam.
15	4705	47	4703	LNeo/EB A	13	600	+++ +						7.5YR 3/2 silt loam.
16	4708	47	4703	LNeo/EB A	3	75	+++ +			+			7.5YR 4/3 silt loam.
17	5404	54	5403		20	40	+++			+			10YR 4/4 sand. Some modern roots.
18	1530 4	153	1530 3		40	14	+	+		++			10YR 4/3 sandy silt loam. Some modern roots.



19	1391 8	139	1391 6	MBA	10	75	+	+++ +		++			7.5YR 5/6 silty clay.
20	1550 4	155	1550 3		20	14	++			+			10YR 4/2 sandy silt loam. Some modern roots.
21	1550 5	155	1550 3		20	10	++			++	+		10YR 4/3 sandy silt loam.
22	1550 7	155	1550 6		9	5	++						10YR 5/4 silty clay loam.
23	1640 5	164	1640 3	LBA/IA	3	5	++	+					10YR 4/3 sandy silt loam.

Key: +=present (up to 5 items), ++=frequent (5-25), +++=common (25-100), ++++=abundant (100+).

Table C.1.1: Assessment of CPR flots.

## C.2 Animal Bone

By Lee G. Broderick

### Introduction

- C.2.1 A total of 160 animal bone specimens were recovered from the site (
- C.2.2 Table C.2.1 **Error! Reference source not found.** **Error! Reference source not found.**), all of which were collected by hand. Features on the site were dated on the basis of associated ceramic finds.
- C.2.3 The hand-collected material was recorded in full, with the aid of the Oxford Archaeology skeletal reference collection and standard identification guides, using a diagnostic zone system (Serjeantson 1996).

### Description

- C.2.4 Preservation on the site was very poor, likely to be due to acid soils and water percolation. No doubt this affected the size of the recovered assemblage and also the proportion which could be identified.
- C.2.5 The specimens that could be identified consisted of red deer (*Cervus elaphus*) antler from late Bronze Age/Iron Age fill 15519 of ditch 15518 in Trench 155 and several dog (*Canis familiaris*) specimens from late Bronze Age/Iron Age fill 15304 of ditch 15303 in Trench 153. The latter specimens were all head elements and probably represent a single individual – a skull (with mandibles) and atlas (the first vertebra adjacent to the skull). It is probable that many of the large mammal and medium mammal specimens from these two contexts (15519 and 15304) represent the same two individuals (red deer and dog).

### Conclusions

- C.2.6 Little can be read into such a small assemblage but it is unusual to have an assemblage of any size which does not include any of the principal domesticates (sheep, domestic cattle and pig). The presence of red deer antler in the BA/IA assemblage may indicate the exploitation of wild resources but it is equally possible that it represents the collection of a shed antler for use in craft activities or as a tool (pick).

**Table C.2.1: Total NISP (Number of Identified Specimens) and NSP (Number of Specimens) figures per period from hand-collected material from the site.**

	BA/IA	IA	Undated
dog		13	
red/fallow deer?	1		
medium mammal		48	
large mammal	94		4
<b>Total NISP</b>	95	61	4

<b>Total NSP</b>	95	61	4
------------------	----	----	---

## C.3 Human Remains

By Mark Gibson

### Introduction and provenance

- C.3.1 One deposit containing burnt human bone (fill 9403, of pit 9402 in Trench 94) was recovered during excavations near Brook Farm. It was in a dark brown grey silty sand matrix which was rich in charcoal inclusions within pit 9402 in Trench 94. The pit was 0.45m wide and 0.12m in depth. The burnt bone was unurned and is currently undated.

### Methodology

- C.3.2 Deposit 9403 was recovered in bulk in accordance with recommended practice (McKinley 2004, 9). It was processed by wet sieving which sorted it into fractions of >10mm, 10-4mm, 4-2mm and 2-0.5mm. The bone from the >10mm, 10-4mm and 4-2mm fractions was separated from the extraneous material (e.g. stones). The smallest fraction sizes (2-0.5mm) were not sorted but were rapidly scanned for identifiable skeletal remains and artefacts. Estimations of the proportions of bone present within the 2-0.5mm fractions were made visually and recorded in the archive.
- C.3.3 All bone was analysed to record colour, weight and maximum fragment size. Total bone weights have not included bone from the 2-0.5mm fraction.
- C.3.4 Each fraction was examined for identifiable bone elements and the presence of pyre and/or grave goods. The minimum number of individuals (MNI) present was estimated based on the identification of repeated elements and/or the presence of juvenile and adult bones in the same deposit. Where possible, estimation of age and sex was attempted following published methods (Buikstra and Ubelaker 1994). The 4-2mm and 2-0.5mm fractions were not available for analysis at the time this report was written.

### Results

- C.3.5 A summary of total bone weight, colour, age and sex estimation is given in Table 1. Information on fragmentation and skeletal elements represented is provided in tables 2 and 3, respectively.

#### *Bone Weight*

- C.3.6 The burnt bone weighed a total of 29.3g (Table B.10.1). This falls well below the expected ranges for both modern (1,000-2,400g, with an average of 1,650g; McKinley 2000, 269) and archaeologically recovered cremation deposits (600-900g, McKinley 2013, 154).

#### *Fragmentation*

- C.3.7 The majority of the burnt bone was from the 4-2mm fraction (62.8%, 18.4g). The remaining 37.2% (10.9g) was from the >10mm fraction. Overall, this indicates a moderate level of fragmentation.
- C.3.8 The largest fragment of bone was a piece of distal right humeral shaft which measured 37mm in length.

### *Skeletal Representation*

- C.3.9 Bones were identified to skeletal region and element, where possible (Table B.10.2). All regions were represented.
- C.3.10 Of the elements which could be identified, the skull was the most frequently identified and comprised 19.8% (5.8g) of the total bone weight (Table B.10.3). This consisted of a fragment of maxilla, a partial orbital margin and multiple vault fragments. The upper limb was also well represented (10.2% of the total bone weight or 3.0g) and included a fragment of distal right humeral shaft. The axial and lower limbs were less well represented, comprising only 3.1% (0.9g) and 2.1% (0.6g) respectively, of the total bone weight.
- C.3.11 The majority of the bone fragments (64.8%, 19g) were lacking anatomical landmarks, so could not be identified. This is with the exception of some fragments which could be identified as long bones (25.9% of total bone weight, 7.6g), but the specific long bone/s could not be determined.

### *Colour of the cremated bone*

- C.3.12 When cremated, the organic content of bone is altered by a process called oxidation, the degree of which is reflected in the colour of the bone, which may range from brown/orange (unburnt), to black (charred: c 300°C), through hues of blue and grey (incompletely oxidised, up to c 600°C) to white (fully oxidised, >600°C) (McKinley 2004, 11). Thus, bone colour may be used as an indication of the efficiency of the cremation, in terms of the quantity of fuel used to build the pyre, the temperature attained in various parts of the pyre, and the length of time over which the cremation was undertaken (ibid, 11).
- C.3.13 All of the burnt bone in deposit 9403 was pure white, without any grey/blue or black fragments. This indicates placement of the corpse on the pyre in such a way as to maintain a consistent high temperature and oxygen supply (McKinley 2013, 158), enabling a temperature in excess of 600°C. A high proportion of fully oxidised bone is a common observation in archaeological cremation burials (McKinley 2006, 84).

### *Demography*

- C.3.14 There were no repeated elements, or landmarks indicating conflicting age or sex estimations. These observations suggest the deposit comprises a minimum of one individual. No features survived which could be used to estimate the age of the individual, but the overall appearance of the burnt bone suggests that they were probably an adult. However, the possibility that they were an older adolescent (mid to late teens), cannot be ruled out.
- C.3.15 One element was available for sex estimation; a partial orbital margin. The margin was neither particularly angular and gracile (female), nor robust and rounded (male), so the estimate is indeterminate (?).

### *Pathology and non-metric traits*

- C.3.16 No pathology or non-metric traits were observed.

### *Pyre/grave goods*

C.3.17 No pyre or grave goods were observed. No staining or residue, indicative of pyre/grave goods, were observed.

### **Discussion**

C.3.18 The total bone weight of deposit 9403 was 29.3g. It comprised one probable adult of indeterminate sex. Overall, bones were well burnt, or predominantly white (fully oxidised), indicating pyre temperatures of >600°C (McKinley 2004, 11). No pathology was observed.

C.3.19 The total weight of the deposit was well below the expected range (600-900g) for archaeologically recovered cremation burials (McKinley 2013, 154). The very low bone weight combined with the high charcoal content of the matrix and the dimensions of pit 9402 (0.45m wide and 0.12m deep) make it highly unlikely that this represents the remains of a formal unurned cremation burial. Rather, it is more likely that it represents redeposited pyre debris or another type of cremation related deposit. It should be noted that pit 9402 was horizontally truncated to an unknown degree, so it is entirely possible that an unknown proportion of the deposit was lost to truncation.

C.3.20 Given the potential that further works will be undertaken in the area of Brook Farm it is recommended that these remains are retained for future research.

C.3.21 The assemblage is currently held at Oxford Archaeology under Ministry of Justice burial licence 19-0317. This licence is valid until the 22nd of December 2024. It should be deferred by application to the Ministry of Justice, stating retention in the local receiving museum.

## Appendix D      References

---

- ACBMG 2007 Ceramic building material, minimum standards for recovery, curation, analysis and publication
- Anderson-Whymark, H, 2015, the flint, in Allen, T, Barclay, A, Cromarty, A, M, Anderson-Whymark, H, Parker, A, Robinson, M, and Jones, G, *Opening the wood, making the Land; The Archaeology of a Middle Thames Landscape, Mesolithic, Neolithic and Bronze Age, Vol 1*, Oxford: Oxford Archaeological Unit. Thames Valley Landscapes Monograph **38**
- Bamford, H., 1985 *Briar Hill: excavation 1974-1978*, Northampton: Northampton Development Corporation. Archaeological monograph **3**
- Barrett, J C, 1988 Pottery, in D Bond *Excavation at the North Ring, Mucking, Essex*, East Anglian Archaeology **43**, 25-37
- Barton, K J, 1962 Settlements of the Iron Age and Pagan Saxon periods at Linford, Essex, *Trans Essex Archaeol Soc*, Vol 1-2, 57-104
- BGS. (2020). *Geology of Britain Viewer*. Retrieved from <http://mapapps.bgs.ac.uk/geologyofbritain/home.html>
- Booth, P, 2016 Oxford Archaeology Roman pottery recording system: An introduction, unpublished
- Buikstra, J E, and Ubelaker, D H, (eds) 1994 *Standards for data collection from human skeletal remains*, Arkansas Archaeological Survey Research Series 44, Arkansas
- Bradley, P. (1999). *The worked flint. In A. Barclay and C. Halpin. Eds. Excavations at Barrow Hills, Radley, Oxfordshire*. Oxford: Oxford Archaeological Unit. Thames Valley Landscapes Monograph 11: 211-227.
- Brudenell, M, 2016a Late Bronze Age Pottery, in C Evans, G Appleby and S Lucy, with J Appleby and M Brudenell *Lives in the Land. Mucking Excavations by Margaret and Tom Jones, 1965-1978: Prehistoric, Context and Summary*, Oxbow Books, 158-88
- Brudenell, M, 2016b Middle Iron Age Pottery, in C Evans, G Appleby and S Lucy, with J Appleby and M Brudenell *Lives in the Land. Mucking Excavations by Margaret and Tom Jones, 1965-1978: Prehistoric, Context and Summary*, Oxbow Books, 365-93
- Brown, N, 1998 Earlier Iron Age pottery, in G A Carter *Excavations' at the Orsett 'Cock' Enclosure, Essex, 1976*, East Anglian Archaeology **86**, 88-9
- Brown, N, 2016 Pottery, in C Evans, G Appleby and S Lucy, with J Appleby and M Brudenell *Lives in the Land. Mucking Excavations by Margaret and Tom Jones, 1965-1978: Prehistoric, Context and Summary*, Oxbow Books, 105-9

- Chartered Institute for Archaeologists (CIfA). (2014a). *Standard and Guidance for Archaeological Evaluation*. Retrieved from <http://archaeologists.net/sites/default/files/node-files/IfASG-Evaluation.pdf>
- Chartered Institute for Archaeologists (CIFA). (2014b). *Standard and Guidance for the Creation, Compilation, Transfer and Deposition of Archaeological Archives*.
- Dewey, H, and Bromehead, C E N, 1915 *The geology of the country around Windsor and Chertsey*, London, H.M. Stationery Office.
- Evans, C, Appleby, G, and Lucy, S. (2016). Lines in the Land: Mucking Excavations by Margaret and Tom Jones, 1965-1978. Prehistory: context and summary. *Cambridge Archaeological Unit Archives Series: Historiography and Fieldwork 2/Mucking 6*.
- Griffiths, S 2014 Points in time: The Mesolithic-Neolithic transition and the chronology of late rod microliths in Britain, *Oxford Journal of Archaeology*, **33** (3) 221-243, 2014
- Harding, P, 1990 The worked flint, in *The Stonehenge environs project*, (ed J C Richards) London, English Heritage
- Healy, F, 1988 The Anglo-Saxon Cemetery at Spong Hill, North Elmham, Part VI: Occupation during the seventh to second Millennia BC, East Anglian Archaeological reports 38
- Hedges, J. D. and Buckley, D. G. 1978. Excavations at a Neolithic causewayed enclosure, Orsett, Essex, 1975. *Proceedings of the Prehistoric Society* 44, 219–308
- Highways England. (2018). *Lower Thames Crossing: A Scheme Wide Specification for Archaeological Trial Trenching: unpublished document HE540039-CJV-GEN-GEN-SPE-HER-00001draft, Revision 1.05*.
- Historic England, 2011 *Environmental Archaeology. A guide to the theory and practice of methods, from sampling and recovery to post-excavation* (2nd edition). Centre for Archaeology guidelines.
- Historic England. (2015). *Management of Research Projects in the Historic Environment: The MoRPHE Project Managers' Guide*. Swindon: Centre for Archaeology Guidelines.
- Inizan, M.-L., Reduron-Ballinger, M, Roche, H and Tixier, J, 1999 *Technology and terminology of knapped stone*, Cercle de Recherches et d'Etudes Préhistoriques, CNRS, Nanterre
- Medlycott, M ed. (2011). *Research and Archaeology Revisited: A Revised Framework for the East of England*. East Anglian Archaeology Occasional Paper 24: Association of Local Government Archaeological Officers.



- McKinley, J I 2000 Cremation burials. In B Barber and D Bowsher, *The Eastern Cemetery of Roman London. Excavations 1983-1990* MoLAS Monograph **4**, 264-277
- McKinley, J I 2004 Compiling a skeletal inventory: cremated human bone, in: M Brickley and J I McKinley (eds.), *Guidelines to the Standards for Recording Human Remains*, IFA Paper No. **7**, BABAO and IFA: Southampton and Reading: 9-13
- McKinley, J I 2006 Cremation...the cheap option? In C Knusel and R Gowland (eds) *The Social Archaeology of Funerary Remains*. Oxbow Books, Oxford: 81-8.
- McKinley, J I 2013 Cremation: excavation and analysis. In S Tarlow and L Nilsson Stutz (eds) *The Oxford Handbook of the Archaeology of Death and Burial*, 147-72, Oxford, Oxford University Press
- MOLA 2014, London medieval and post-medieval pottery codes, Museum of London Archaeology, <http://www.mola.org.uk/medieval-and-post-medieval-pottery-codes> (Accessed 11 Jan 2019)
- Onhuma, K and Bergman, C A, 1982 Experimental studies in the determination of flake mode, *Bulletin of the Institute of Archaeology, London* **19**, 161-171
- Oxford Archaeology. (2019a). *Lower Thames Crossing Scheme-wide Written Scheme of Investigation for Trial Trenching south of the River Thames*.
- Oxford Archaeology. (2019b). *Lower Thames Crossing Scheme-wide Written Scheme of Investigation for Trial Trenching north of the River Thames*.
- Oxford Archaeology. (2019c). *Lower Thames Crossing Detailed Written Scheme of Investigation for Trial Trenching of Land Parcel 5*. Oxford Archaeology.
- Place Services. (2019). *Lower Thames Crossing Aerial Investigation and Mapping Report, Essex County Council*.
- Pearce, J E, Vince, A G, and White, R, with Cunningham, C M, 1982, A dated type-series of London medieval pottery, Part 1: Mill Green Ware, *Trans London Middlesex Archaeol Soc*, **33**, 266-98
- Schofield, T, 2010 Mill House Farm, Chadwell St Mary, Essex, Archaeological Evaluation, Archaeological Solutions Ltd
- Serjeantson, D. (1996). Animal Bone. In: Needham, S. and Spence, T. (Eds). *Runnymede Bridge Research Excavations, Volume 2: Refuse and Disposal at Area 16 East, Runnymede*. London : British Museum Press. pp.194–223.
- Thurrock Local History Society 2019

## Appendix E      Abbreviations and Glossary

---

**ADS** Archaeology Data Service. Digital archaeological archive

**CDM** Construction Design Manual. Health and safety guidance for the construction industry

**CPD** Continuing Professional Development

**CIfA** Chartered Institute for Archaeologists

**DBA** Desk Based Assessment. Detailed assessment of archaeology and other aspects of the historic environment

**DCO** Development Consent Order

**EIA** Environmental Impact Assessment. Detailed study of environmental impacts as directed under the The Town and Country Planning (Environmental Impact Assessment) Regulations 2017 following on from EU Directive EIA Directive (85/337/EEC)

**ES** Environmental Statement. The principal environmental report detailing environmental impacts within an EIA

**GPS** Global Positioning System

**HER** Historic Environment Record

**LTC** Lower Thames Crossing

**MCIfA** Member of the Chartered Institute for Archaeologists

**MoRPHE** Management of Research Projects in the Historic Environment

**NMP** National Mapping Programme. A study of aerial photographs and digitisation of resulting data into GIS. Originally funded by Historic England

**OASIS** Online Access to the Index of archaeological investigations.  
The OASIS project brings together a number of strategic partners: the Archaeology Data Service, Historic England, Historic Environment Scotland, and the Royal Commission on the Ancient and Historical Monuments of Wales under the umbrella of the University of York

**OCN** Old County Number. Historic England's reference for material that is not readily-available online and may represent historic archaeological work that consists of paper archives or has yet to be formally reported on

**PINS** Planning Inspectorate

**RAMS** Risk Assessment Method Statement

**SMC** Scheduled monument consent

**TDR** Trusted Digital Repository

**UKIC** United Kingdom Institute for Conservation

**WSI** Written Project of Investigation. A detailed method statement for archaeological work

**WSL** – Western Southern Link  
The Western Southern Link (WSL) is an alternative for Short List Routes 2, 3 and 4 to the south of the River Thames.

## Appendix F Site Summary

---

<b>Site name:</b>	Lower Thames Crossing Land Parcel 5 Brook Farm, Chadwell-St-Mary, Essex
<b>Site code:</b>	LTC5BF19
<b>Grid Reference</b>	NGR TQ 65603 79864
<b>Type:</b>	Evaluation
<b>Date and duration:</b>	6 January – 14 February 2019
<b>Area of Site</b>	32.59ha
<b>Location of archive:</b>	The archive from Land Parcel 5 will form part of the overall trial trenching scheme archive. This will be deposited in a repository consistent with the standards required by the Museums and Galleries Commission following completion of the archaeological phase of this project. This may either be with the local receiving museum in Thurrock or, if no such repositories are available, with a repository for the whole project designated by LTC. LTC retain the overall responsibility for the successful deposition of the project archive.

Currently, the archive is held at Oxford Archaeology's head office, Janus House, Osney Mead, Oxford, Oxfordshire, OX2 0ES. Oxford Archaeology will store the archive for LTC for a maximum period of 2 years following the completion of the project. If the storage of the archive at OA's office extends past this period, an extension to the storage period and final deposition timetable will be reviewed by OA and LTC and agreed with the major stakeholders.

**Summary of Results:** Oxford Cotswold Archaeology was commissioned by Balfour Beatty to undertake a trial trench evaluation of Land Parcel 5 of the Lower Thames Crossing Pre-Enabling Works. Land Parcel 5, also known as Brook Farm, is located directly north east of the town of Chadwell St Mary (Fig. 1) within the county of Essex and Thurrock unitary authority (NGR 565631 179802335). The evaluation comprised 168 trenches and was completed between 6 January and the 14 February 2020.

The earliest recorded activity on site comprised a single pit from a trench in the south-central part of the site containing Beaker pottery and abundant charcoal. A cropmark suggesting the presence of a ring-ditch in the central part of the site was investigated by a single trial trench but did not produce any dating evidence.

Two trenches at the eastern end of the site contained features dated to the Middle Bronze Age and Late Bronze Age to Iron Age respectively. Two of these features correlated with a cropmark representing a sub-rectangular enclosure, suggesting the presence of an enclosure of Middle Bronze Age date.

A scatter of linear features and colluvial deposits in seven trenches along the northern edge of the site produced late Bronze Age to Iron Age pottery, suggesting a focus of activity of this date. In addition, two trenches in the southern central part of the site produced a pit containing late Bronze Age to early Iron Age pottery and middle to late Bronze Age pottery respectively. These features were situated to the south of some undated linear cropmarks that were not aligned on modern field boundaries. There is therefore some limited evidence for middle and late Bronze Age activity across the central section of the site.

Four trenches in the south-eastern corner of the site contained pits and linear ditches producing occasional sherds of late Bronze Age to Iron Age date, but also two sherds of Roman date, this suggests an activity focus of late Bronze to Iron Age date, with additional Roman activity in the south-east corner of the site.

Very occasional sherds of Roman pottery from topsoil and colluvial layers across the site suggest very limited activity of this date of unspecified character. In addition, a trench at the western end of the site contained two pits with medieval pottery from their fills, which perhaps suggest sand or gravel digging activity.

Linear and curvilinear cropmarks at the western end of the site and on the southern boundary align with the field boundaries shown on the first edition OS map, suggesting that they represent post-medieval field boundaries themselves.

The site contained a large number of irregular-shaped features, 1-3m in diameter, which were identified as cropmarks and were targeted in numerous trenches. Where investigated, these comprised variations in the gravel or sand and silt content of the geology and were clearly not of archaeological origin.

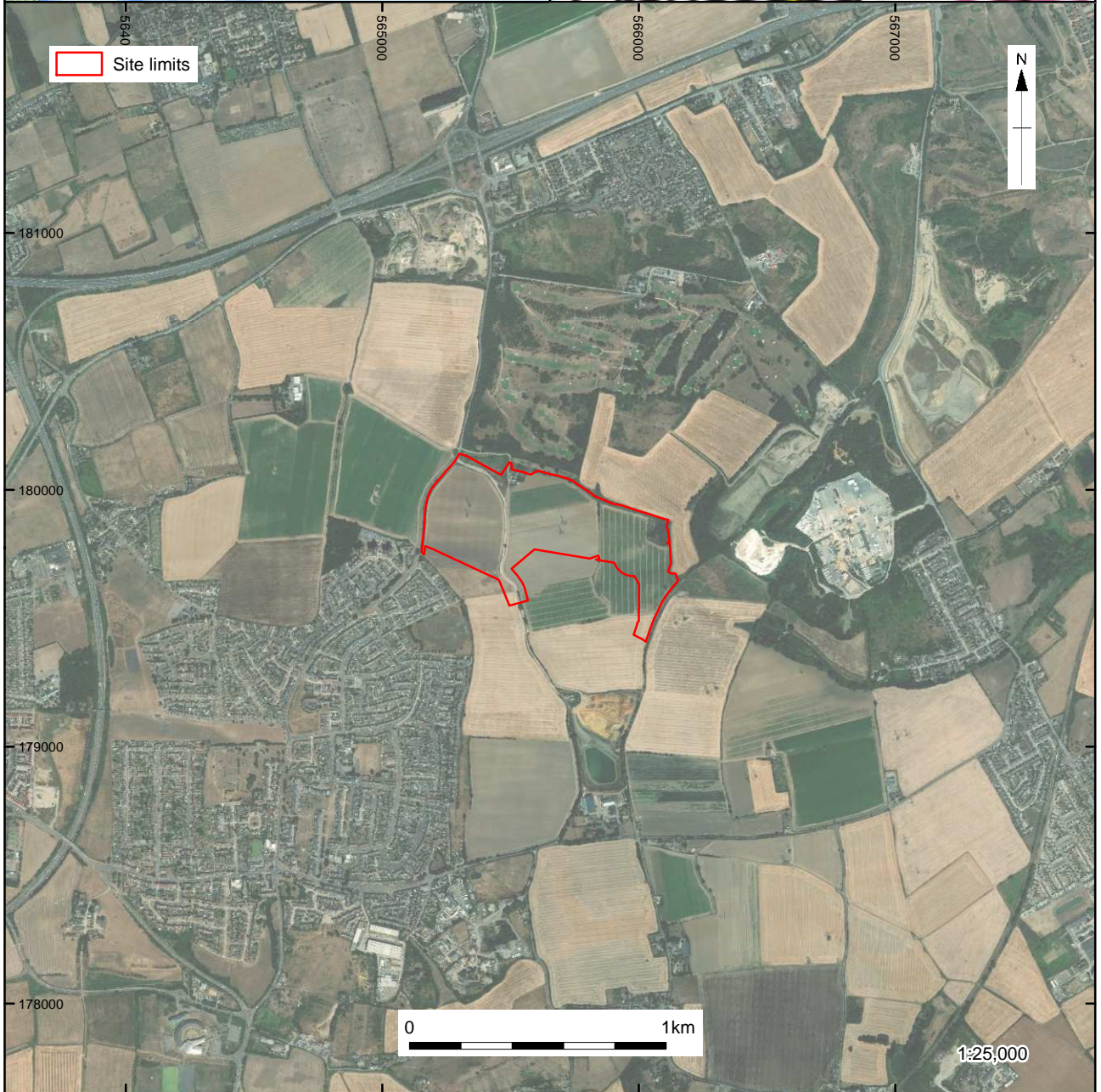
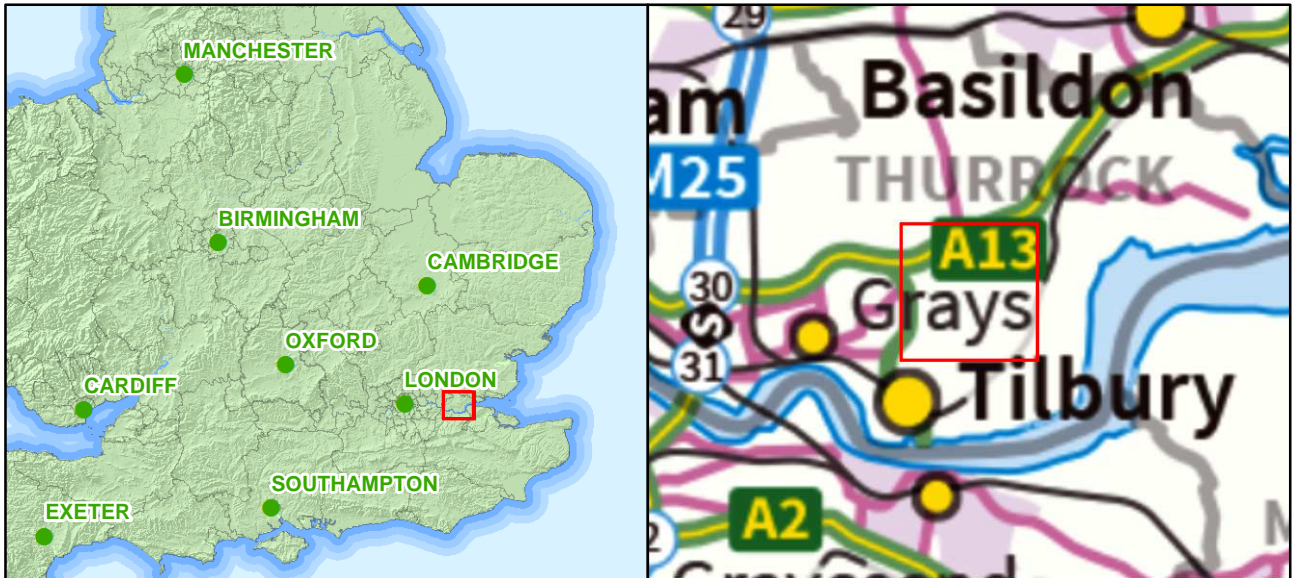

Source: Esri, DigitalGlobe, GeoEye, Earthstar Geographics, CNES/Airbus DS, USDA, USGS, AeroGRID, IGN, and the GIS User Community

Figure 1: Site location

X:\IL\TOEV\_Lower\_Thames\_Crossing\010\Geomatics\03 GIS Projects - L\TC5BF19\Figures\NewL\TC5BF19\Fig1.mxd\aidan.farnan\03/03/2020

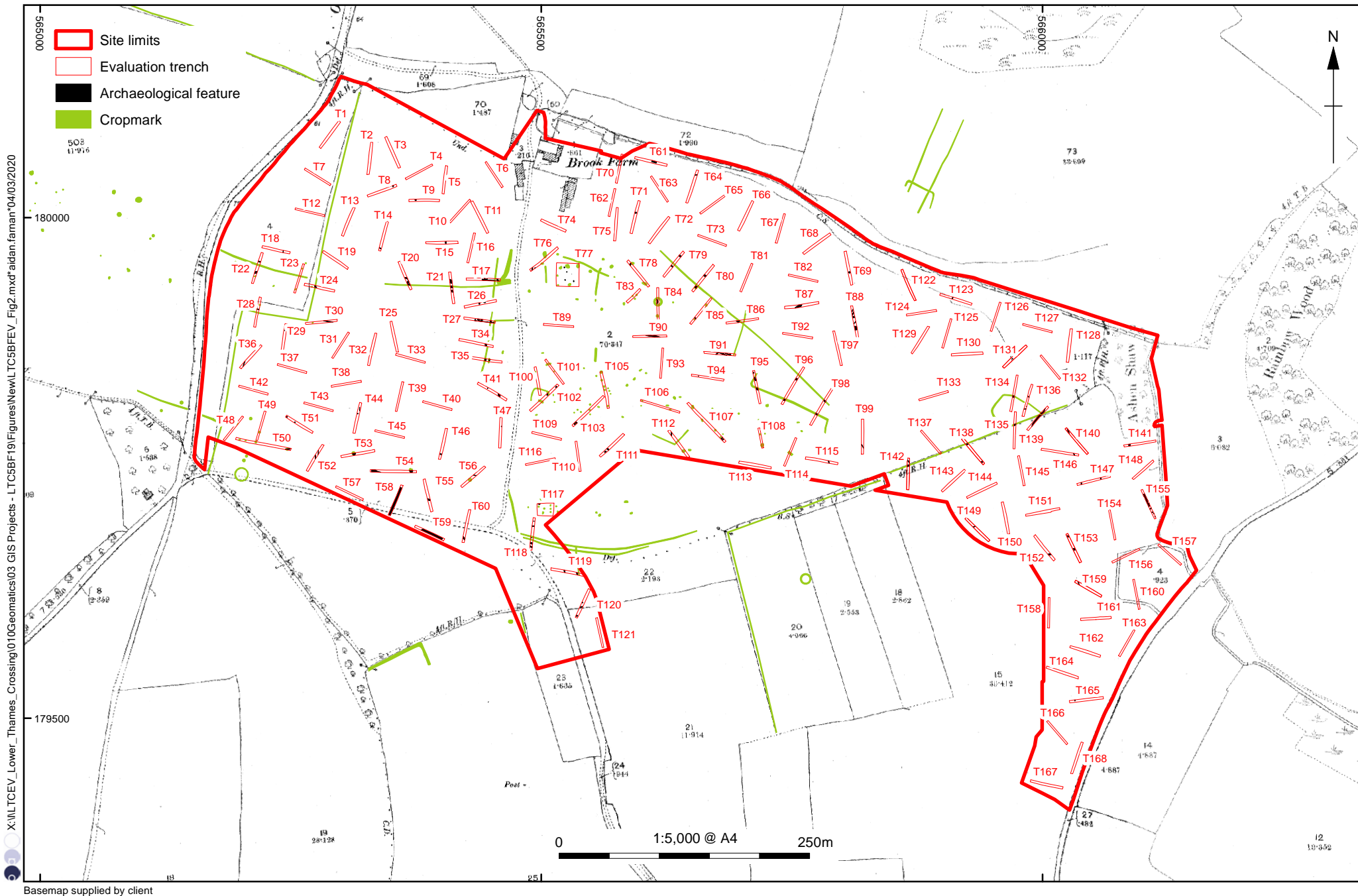

Figure 2: Plan of trench layouts, cropmark features and archaeological features showing 1st Edition OS Mapping

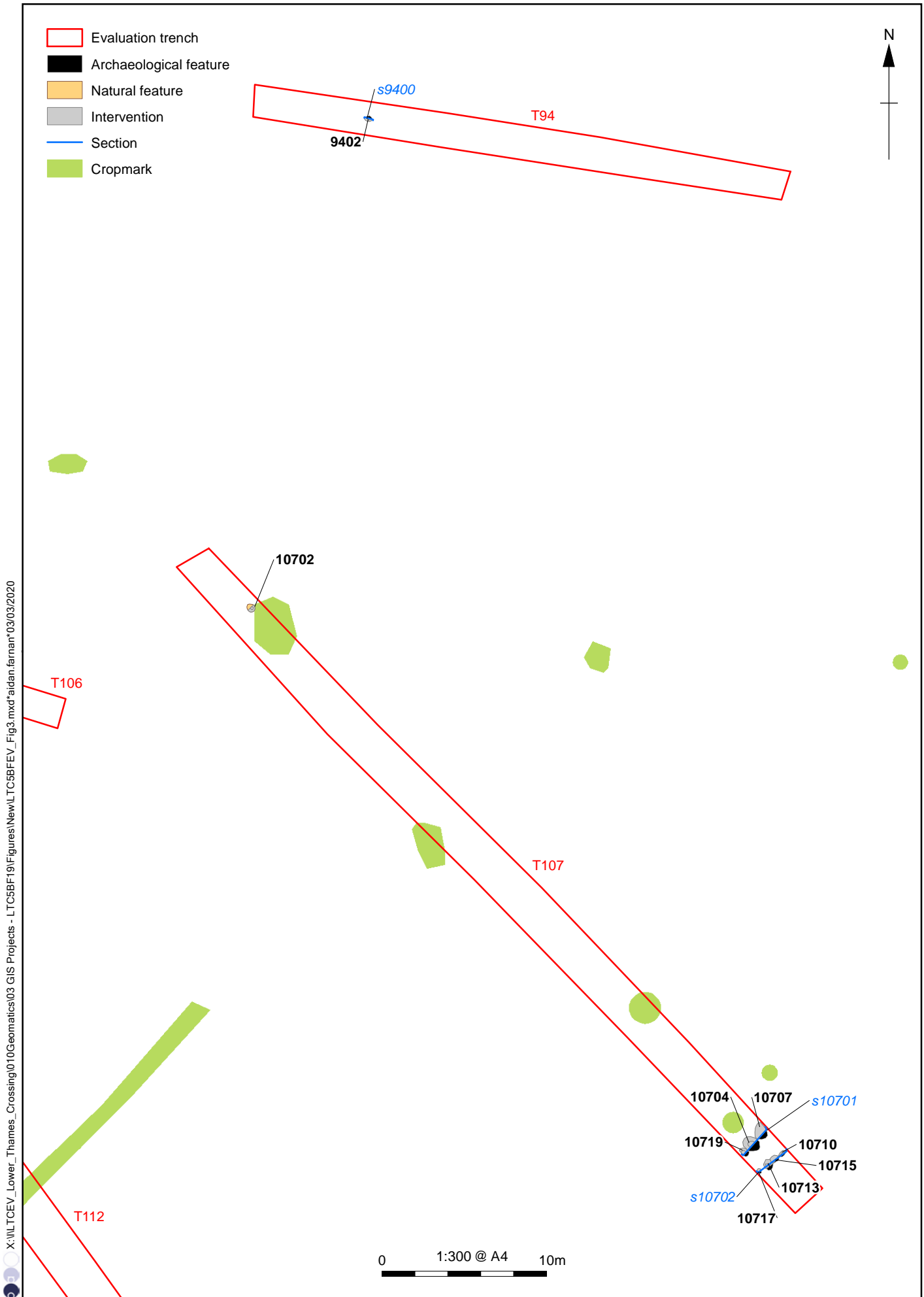

Figure 3: Plan of Trenches 94 and 107, with late Bronze Age/iron Age pit 9402 and Neolithic/Bronze Age pit/tree-throw groups

- Evaluation trench
- Archaeological feature
- Intervention
- Section

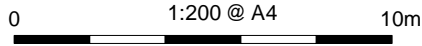

Figure 4: Plan of Trench 47 and Beaker pit 4703



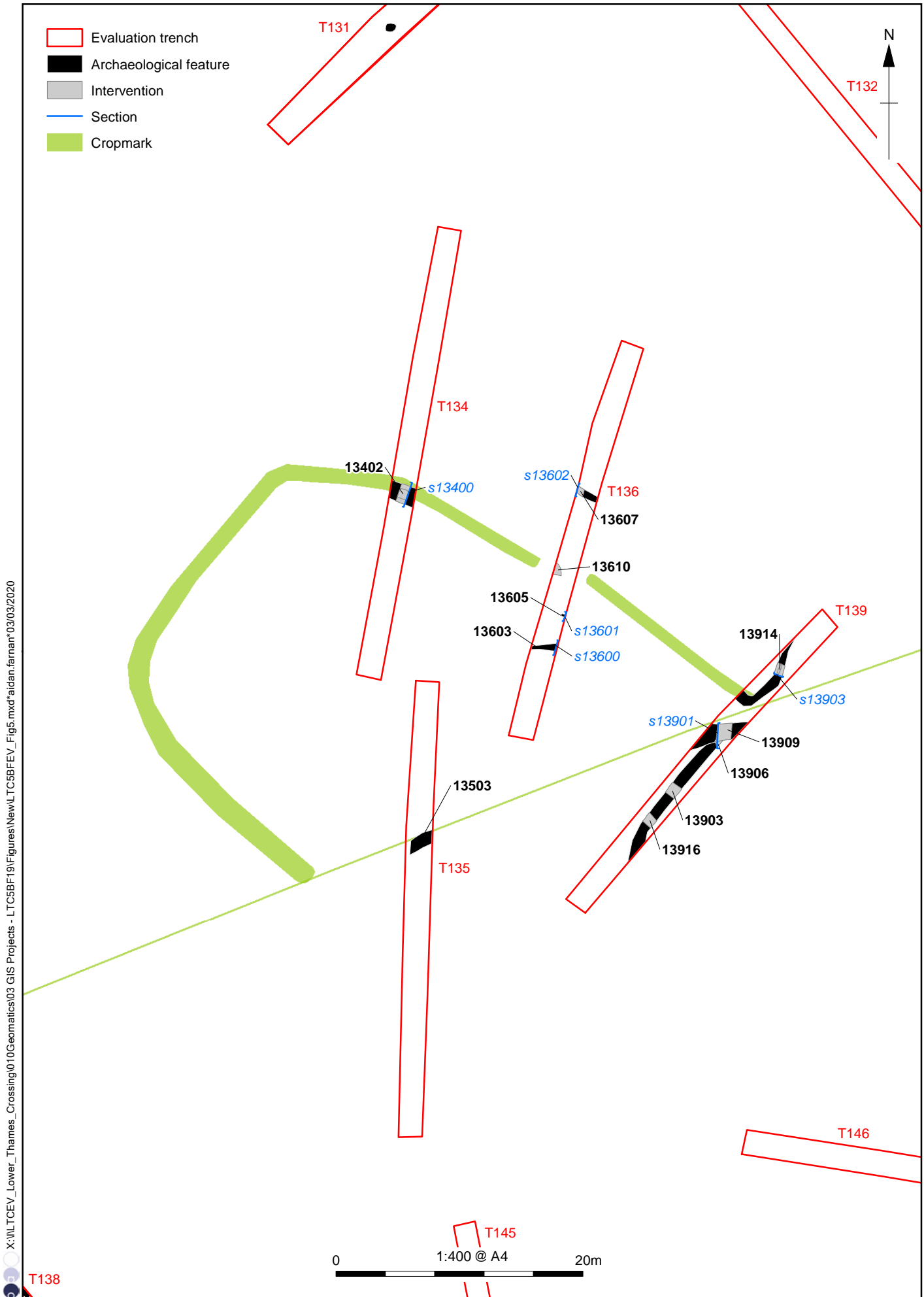

Figure 5: Plan of cropmark enclosure and middle Bronze Age features in Trenches 134, 135, 136 and 139

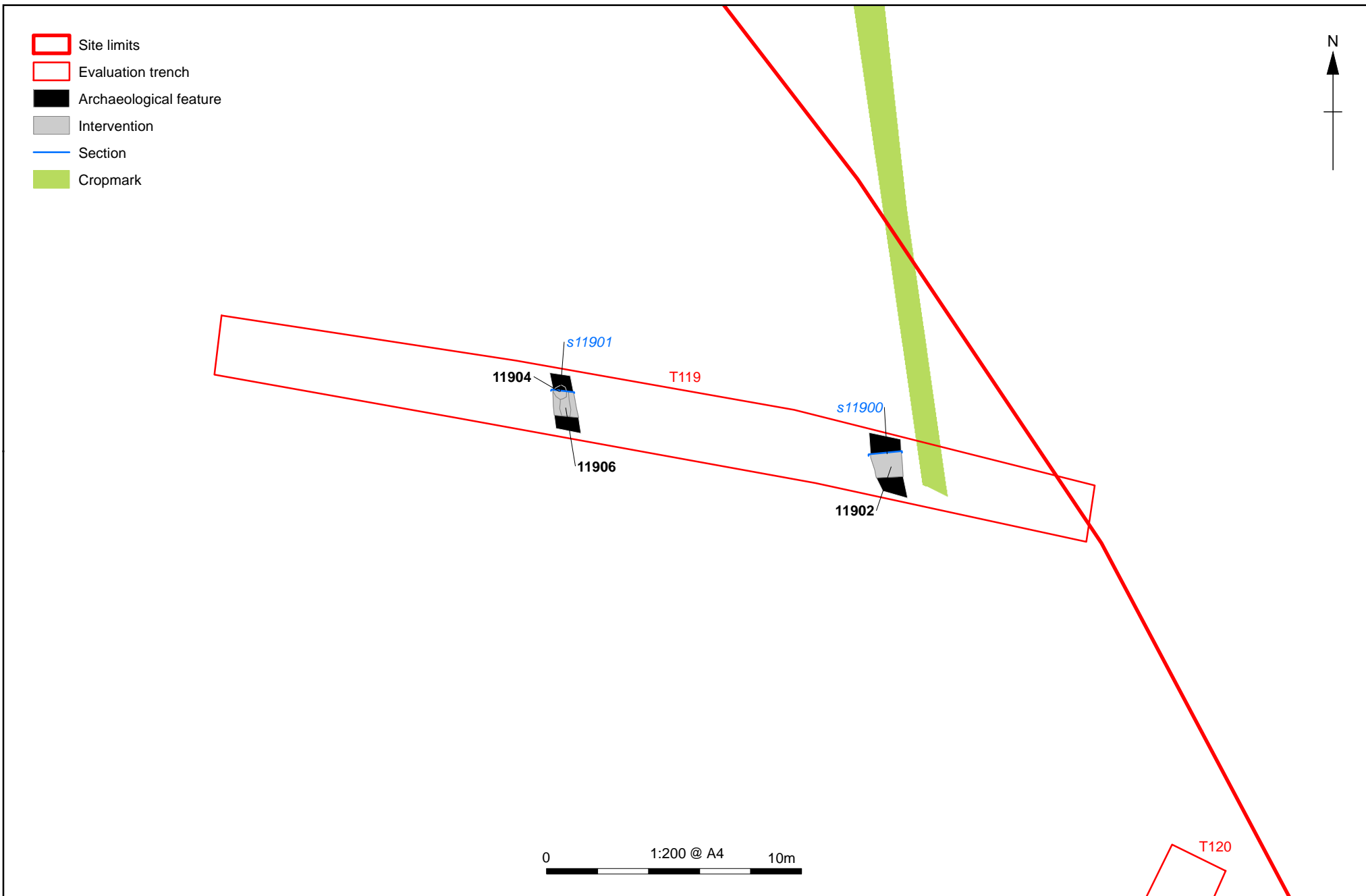

Figure 6: Plan of Trench 119 and MBA-LBA ditches 11902 and 11906

- Site limits
- Evaluation trench
- Archaeological feature
- Intervention

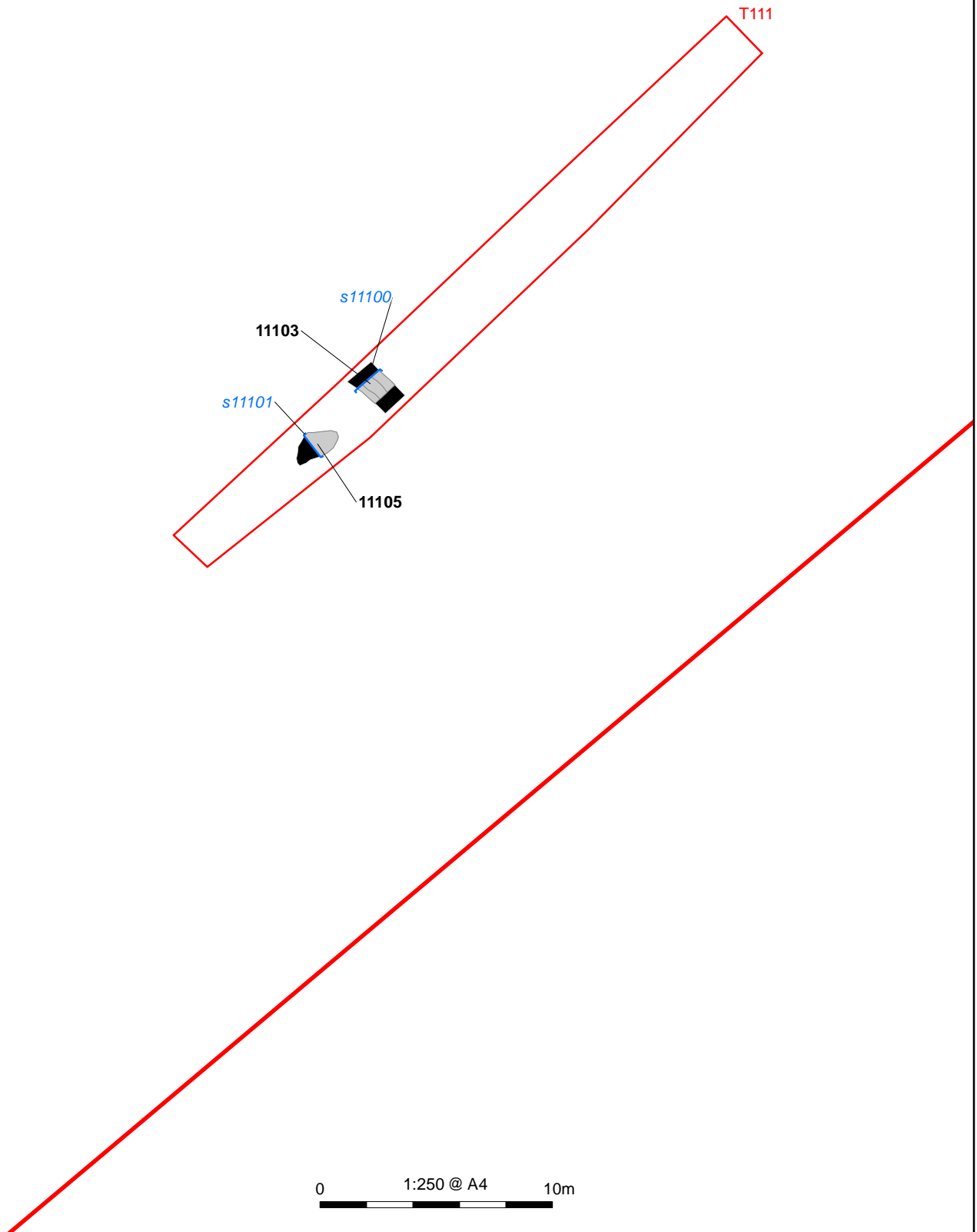

Figure 7: Plan of Trench 111 with LBA-IA pit 11105 and ditch 11103

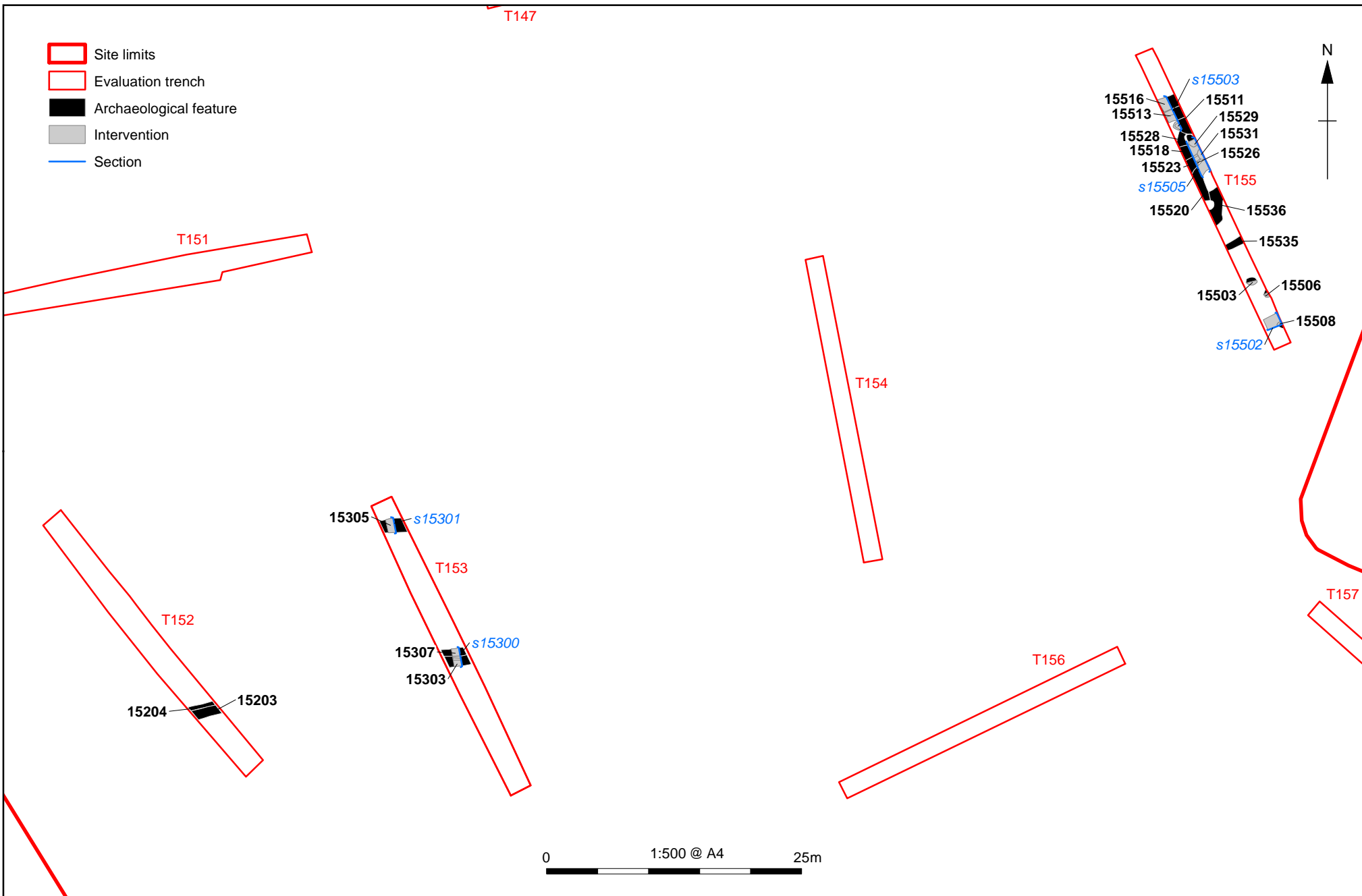

Figure 8: Plan of Trenches 151 to 156

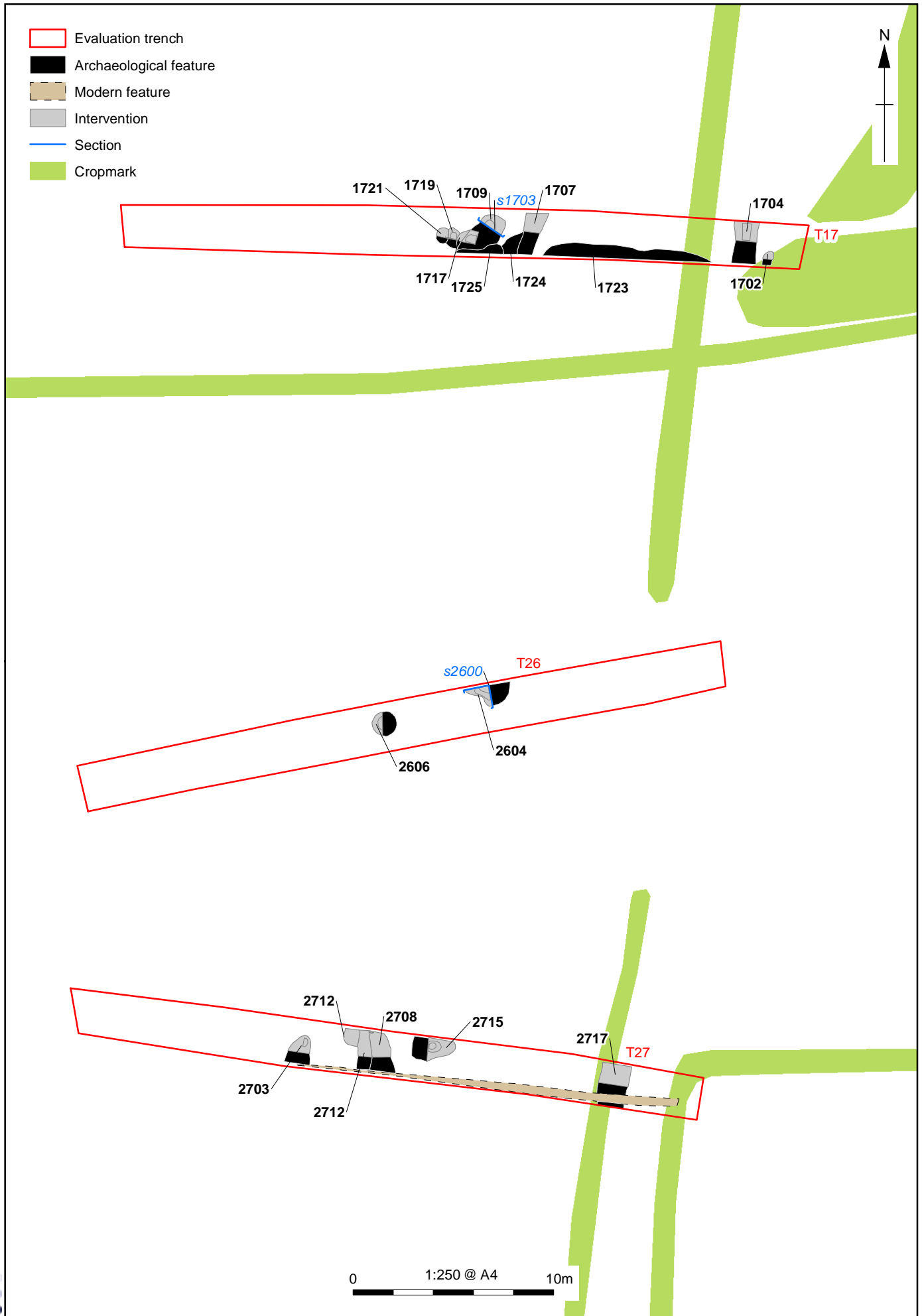

Figure 9: Plan of Trenches 17 and 26 with late Bronze Age/Iron Age ditch 1709 and medieval pits 2604, and 2606

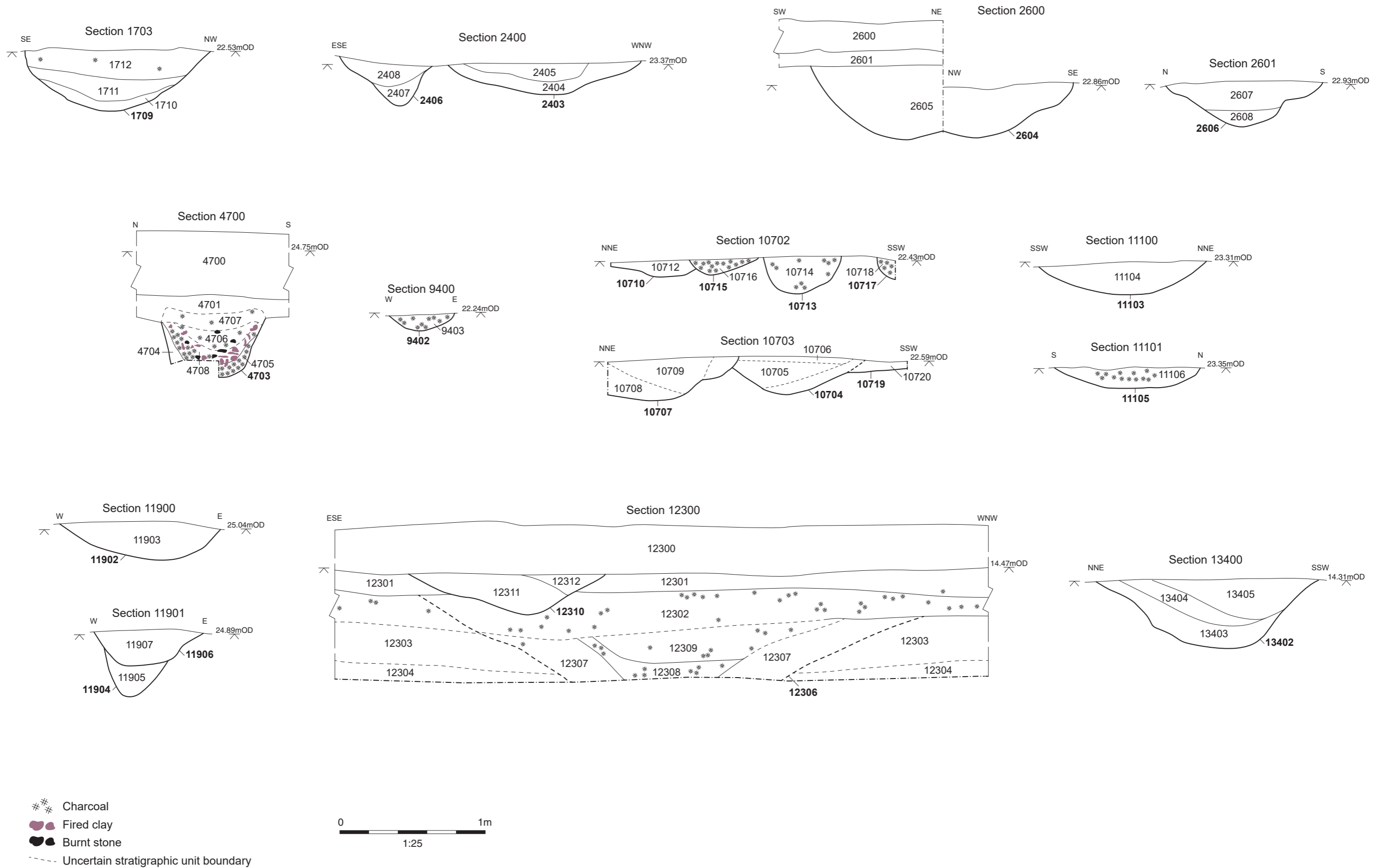

Figure 10: Sections (Trenches 17, 24, 26, 47, 94, 107, 111, 119, 123 and 134)

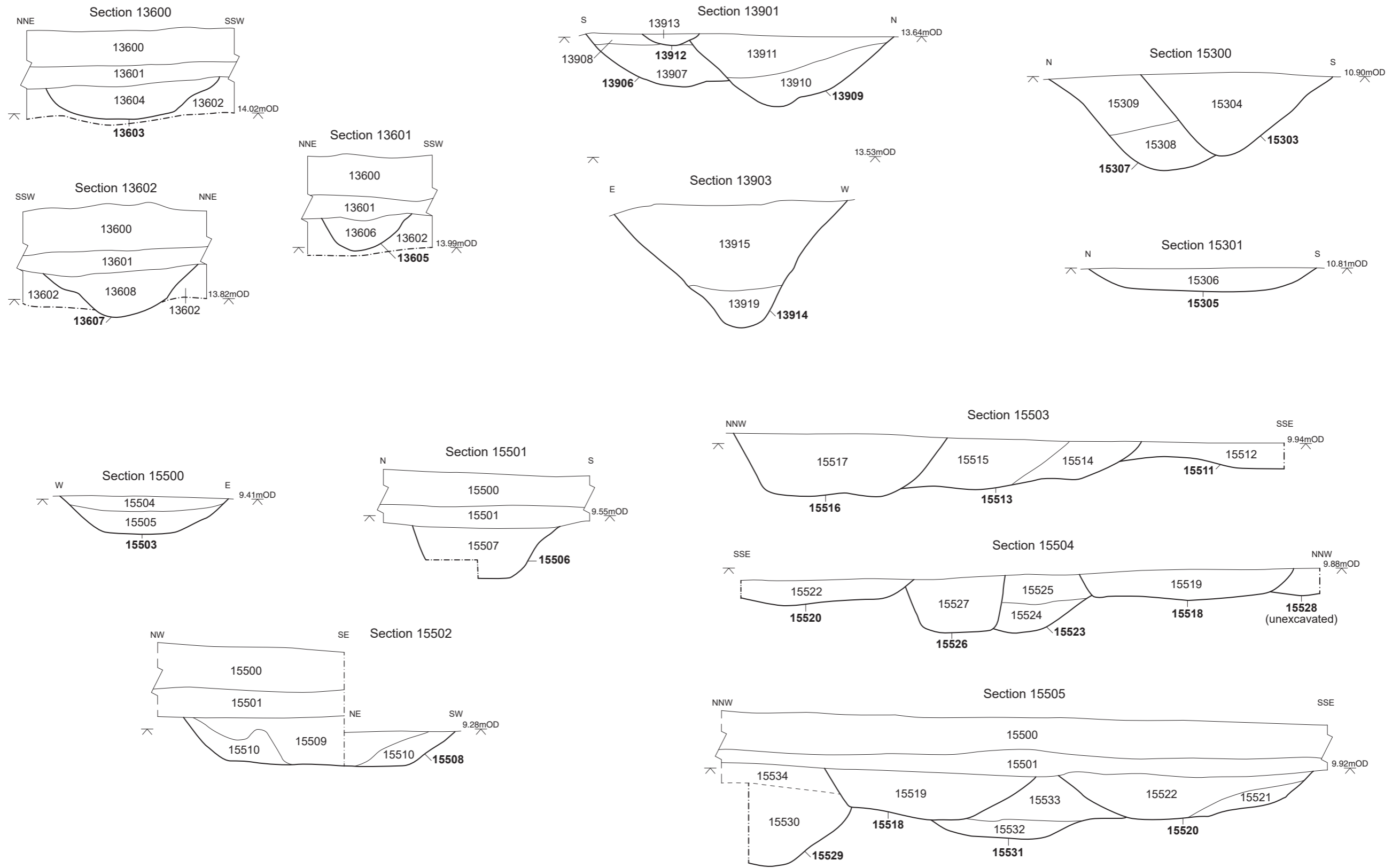

Figure 11: Sections (Trenches 136, 139, 153 and 155)

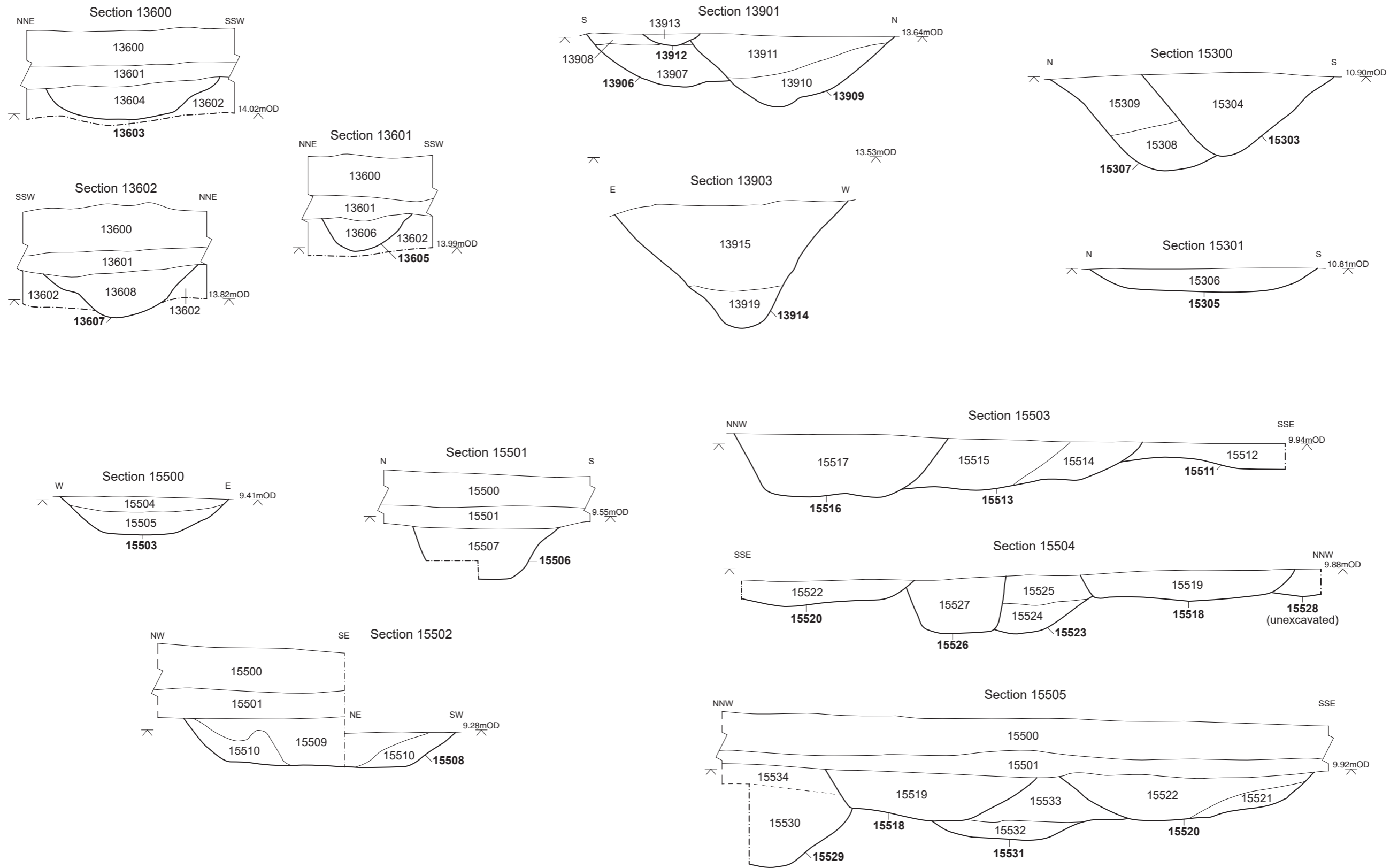

Figure 12: Sections (Trenches 136, 139, 153 and 155)





Plate 1: Pit 4703, W facing



Plate 2: Ditches 13906 and 13909, W facing



Plate 3: Ditch 13914 with middle Bronze Age pottery, SW facing



Plate 4: Trench 155, S facing



Plate 5: Ditches 11902 and 11906, N facing



Plate 6: Pits 2604 and 2606, NE facing

## COVER SHEET

<b>Title:</b>	<b>Archaeological Evaluation Report for Trial Trenching of Land Parcels 6, 8, 9, 10 and 36</b>
<b>Project Name:</b>	<b>Lower Thames Crossing Enabling Works</b>
<b>Ref No:</b>	<b>HE540039-BAL-GEN-GEN-REP-HER-00035</b>
<b>Revision No:</b>	<b>P01</b>
<b>Review Date:</b>	<b>22/01/2021</b>
<b>Status:</b>	<b>S2 – For Information</b>
<b>No. of Pages</b>	<b>189</b>

<b>Rev</b>	<b>Date of Issue</b>	<b>Revision Status</b>	<b>Originator</b>	<b>Checker</b>	<b>Approver</b>
P01	22/01/2021	S2 For Information	Bikash Rana	Jack Fletcher	Emily Erswell



# Lower Thames Crossing

Archaeological Evaluation Report for Trial Trenching of  
Land Parcels 6, 8, 9, 10 and 36  
Land between West and East Tilbury, Essex

Document Number: HE540039-BAL-GEN-GEN-REP-HER-00035

January 2021



Revision	Production Date	Prepared by	Checked by	Approved for release by	Sections revised
1.0	11th January 2021	Jonathan Orellana Cotswold Archaeology	Tim Allen, Senior Project Manager, Oxford Archaeology	Internal review only	
1.1	21st January 2021	Revised by Tim Allen, Senior Project Manager, Oxford Archaeology	Steve Lawrence, Senior Project Manager, Oxford Archaeology		

This Evaluation Report has been prepared for Highways England in accordance with the terms and conditions of appointment stated in the Lower Thames Crossing (LTC) Technical Partner Contract. LTC cannot accept any responsibility for any use of or reliance on the contents of this document by any third party.

# Contents

---

Section	Page
<b>Summary</b> .....	<b>8</b>
<b>Acknowledgements</b> .....	<b>9</b>
<b>1 Introduction</b> .....	<b>10</b>
1.1 Project details and scope of work .....	10
1.2 Location, topography and geology .....	10
1.3 Previous investigations .....	11
1.4 Archaeological and historical background.....	12
<b>2 Project Aims</b> .....	<b>20</b>
2.1 General aims .....	20
2.2 Specific objectives .....	21
<b>3 Methodology</b> .....	<b>23</b>
3.1 Constraints.....	23
3.2 Methodology for the evaluation .....	23
<b>4 Results</b> .....	<b>24</b>
4.1 Introduction and presentation of results .....	24
4.2 General soils and ground conditions.....	24
4.3 General distribution of archaeological deposits .....	24
4.4 Trenches 7, 8, and 220-2 (Figs 6 and 8).....	25
4.5 Trenches 17 and 20 (Figs 7 and 8).....	26
4.6 Trenches 35 and 36 (Fig. 3).....	26
4.7 Trenches 63, 64, 73, 77 and 81 (Figs 9 and 10).....	27
4.8 Trench 49 and 53 (Figs 3 and 10).....	27
4.9 Trenches 87 and 98 (Figs 4 and 11).....	28
4.10 Trenches 106-10, 115-18 and 128 (Figs 11 and 12).....	28
4.11 Trenches 120-3 (Figs 13 and 14).....	30
4.12 Trenches 132, 134-8, and 140-1 (Figs 15, 22 and 23).....	32
4.13 Trenches 142, 144-5, 147 and 152 (Fig. 16).....	33
4.14 Trenches 199, 200, 205, 211, 225 and 240 (Fig. 17).....	34
4.15 Trenches 168 and 171 (Fig. 19).....	35
4.16 Trenches 175, 182-3 and 185 (Fig. 20).....	36
4.17 Trenches 214 and 216 (Fig. 22).....	36
4.18 Trenches 233, 237 and 238 (Fig. 23).....	36
4.19 Finds summary .....	37
4.20 Environmental summary .....	38
<b>5 Discussion</b> .....	<b>39</b>
5.1 Reliability of field investigation .....	39
5.2 Interpretation.....	39
5.3 Evaluation objectives and results.....	42
<b>Appendix A Trench Tables</b> .....	<b>45</b>
<b>Appendix B Finds Reports</b> .....	<b>118</b>

<b>Appendix C</b>	<b>Environmental Reports .....</b>	<b>133</b>
<b>Appendix D</b>	<b>References .....</b>	<b>148</b>
<b>Appendix E</b>	<b>Abbreviations and Glossary .....</b>	<b>151</b>
<b>Appendix F</b>	<b>Site Summary.....</b>	<b>152</b>



## Figures

Figure 1: Site location

Figure 2: Plan of trench layout, showing cropmarks

Figure 3: Plan of west trench layout, showing cropmarks and features, with insets of Trenches 35-36 and 49-53

Figure 4: Plan of east trench layout, showing cropmarks and features

Figure 5: Plan of south trench layout, showing cropmarks and features

Figure 6: Plan of Trenches 7, 8, 220, 221 and 222

Figure 7: Plan of Trenches 17 and 20

Figure 8: Sections 22001, 22201 and 2000

Figure 9: Plan of Trenches 63, 64, 73, 77 and 81

Figure 10: Sections 5300, 6401 and 8100

Figure 11: Plan of Trenches 98, 106-10, 115-18 and 128

Figure 12: Sections 10700, 10902, 10903, 10906, 11600 and 12801

Figure 13: Plan of Trenches 120-3

Figure 14: Section 12301

Figure 15: Plan of Trenches 132, 134-5 and 137-41

Figure 16: Plan of Trenches 142, 144-5, 147 and 152

Figure 17: Plan of Trenches 193, 199, 200, 205, 211, 225 (inset) and 240

Figure 18: Sections 14400, 16800 and 24001

Figure 19: Plan of Trenches 168 and 171

Figure 20: Plan of Trenches 175, 182-3 and 185

Figure 21: Sections 17500, 18200 and 18300

Figure 22: Plan of Trenches 214-18

Figure 23: Plan of Trenches 233-8

Figure 24: Section 14100

Figure 25: Section 14001

Figure 26: Geoarchaeological transect across Trenches 132, 134-5, 137-8 and 140-1

## Plates

Plate 1: Ditch 22005, looking north-east

Plate 2: Ditch 22207 and pit 22205, looking south

Plate 3: Pit 6403, looking south

Plate 4: Fired clay objects in pit 6403, looking south

Plate 5: Pit 8103, looking south

Plate 6: Ditch 10910, looking north-west

Plate 7: 10925, *in situ* ceramic vessel

Plate 8: Section 12802, looking south-west

Plate 9: Pits 12306 and 12308, looking south-west

Plate 10: Ditch 24005, looking north-west

Plate 11: Geoarchaeological Section 13200

Plate 12: Geoarchaeological Section 13400

Plate 13: Trench 135

Plate 14: Geoarchaeological Section 13701

Plate 15: Geoarchaeological Section 13800

Plate 16: Geoarchaeological Section 14100

Plate 17: Geoarchaeological Section 14100 showing location of samples

Plate 18: Geoarchaeological Section 14001

## Tables

Table 1: Prehistoric pottery

Table 2: Quantification of late Iron Age and Roman fabrics (codes in brackets from Tomber and Dore 1998)

Table 3: Description of post-Roman pottery by context

Table 4: Quantification of flint by context

Table 5: Summary of fired clay assemblage

Table 6: Summary of CBM assemblage

Table 7: Description of metalwork by context

Table 8: Assessment of CPR bulk samples

Table 9: Summary of osteological findings

Table 10: Summary of geoarchaeological sections

Table 11: Summary of sampled colluvial sequences

## Summary

---

Oxford Cotswold Archaeology was commissioned by Balfour Beatty to undertake a trial trench evaluation of land parcels 6, 8, 9, 10 and 36 covered by WSI I of the Lower Thames Crossing Pre-Enabling Works. These land parcels are located between West Tilbury and East Tilbury within the county of Essex and Thurrock unitary authority (NGR 566860 178384). A total of 230 trenches were dug and recorded between 20th August and 7th October 2020.

The earliest archaeological evidence recorded during the evaluation was represented by a small assemblage of residual Mesolithic/Neolithic blade-based flints retrieved from a small undated ditch in the northern part of the site. A ditch containing a small amount of early Neolithic pottery and flints including a flint scraper was revealed at the north-eastern edge of the site, and colluvium at the north-west edge contained fresh Neolithic flintwork and pottery potentially of early Neolithic date.

Evidence of later prehistoric activity was scattered right across the site, but with a possible focus in the centre. Four circular pits, one containing middle Bronze Age pottery, the others late Bronze Age pottery, in association with hearths, oven furniture and charred plant remains, were found in the northern and central parts of the site, and later Bronze Age struck flint in colluvium and an erosion gully in a dry valley. Small amounts of pottery of later Bronze Age or early Iron Age date came from several other pits and small ditches in the northern and eastern parts of the site.

The centre of the site contained cropmarks of a sub-rectangular enclosure with an associated field system, and a circular smaller enclosure adjacent on the west. No finds came from the curving ditch of the circular cropmark, but two unurned cremation pits were found within the area enclosed by the curvilinear ditch, and although not dated, may well indicate a small Bronze Age barrow or flat cemetery. To the east, and within the sub-rectangular enclosure, a later Bronze Age or early Iron Age complete ceramic vessel had been placed upright in a pit, and may represent associated activities. The only finds from the sub-rectangular enclosure ditches were a couple of small sherds, one of late Iron Age/early Roman or 10-11th century date, the other of early Medieval date, in the top of one ditch. The sub-rectangular enclosure is not therefore securely dated, and no finds were recovered from the associated field system.

Two ditches located in the western and central parts of the site contained small, abraded quantities of late Iron Age/Roman pottery indicated very limited Roman activity. Two isolated medieval pits, one containing pottery, the other a horseshoe, were found in the southern and eastern parts of the site.

A boundary ditch and two very large pits, probably indicating quarries, all containing Tudor pottery and 16th -18th century CBM, were revealed at the very south end of the site adjacent to the hamlet of Low Street. Several ditches that corresponded to historic mapping were also recorded.

## Acknowledgements

---

Oxford Cotswold Archaeology would like to thank the client, Balfour Beatty, for commissioning this project and managing the site safety and attendances. Thanks are also extended to the Historic Environment Consultants (Richard Havis and Katie Lee-Smith) of Place Services at Essex County Council, who advise the Borough of Thurrock, for monitoring and providing advice throughout the project.

The project was managed for Oxford Cotswold Archaeology by Steve Lawrence. The fieldwork was directed by Mark Dodd and supervised by Jonathan Orellana, who were supported by Jeremy Clutterbuck, Francesco Catanzaro, George Gurney, Eilidh Barr, Anne-Laure Bollen, Kat Whitehouse, Christoff Heisterman, Tom Lawrence, Chris Griffiths, Richard Spencer, Heloise Meziani, Stephen Foster, Kerry Kendall, Melanie Sayer, Steve Arrow, Tim Street, Lara Tonizzo, Benjamin Camp, Chloe Merrett and Edmund Cole. Site survey was undertaken by Caroline Souday and digitising was carried out by Caroline Souday and Charles Rousseaux.

Thanks are also extended to the teams of OA staff that cleaned and packaged the finds under the management of Leigh Allen and Geraldine Crann, processed the environmental remains under the management of Rebecca Nicholson, and processed and indexed the images under the management of Nicola Scott. We are also grateful to Leigh Allen and Nicola Scott for the preparation of the finds archive and documentary and digital archives respectively.

# 1 Introduction

---

## 1.1 Project details and scope of work

- 1.1.1 The Lower Thames Crossing Project is located between the A2 in Kent and the M25 in the London Borough of Havering. It will run underneath the River Thames through a tunnel and emerge on the northern side of the river at East Tilbury. From the North Portal the road will run to the M25 at Junction 29 via the A13 and pass between North and South Ockendon. The development of the project is managed by LTC, a partnership between Highways England and a consultancy joint venture set up to oversee the scheme.
- 1.1.2 A programme of archaeological trial trenching commenced in the Essex part of the scheme in November 2019. A scheme-wide specification for trial trenching was written by LTC (Highways England 2018), and in July 2019, LTC commissioned Balfour Beatty to deliver the pre-Enabling Works. Balfour Beatty appointed Oxford Archaeology (OA) to prepare a project-wide written scheme of investigation (WSI) for the scheme, which (at the request of the key archaeological stakeholders) is divided into two parts, one for the Kent section, and another for Essex and Havering (Oxford Archaeology 2019).
- 1.1.3 Following completion of the project-wide WSIs, OA was instructed to prepare a series of site-specific or group-site specific WSIs for approval by the key archaeological stakeholders in advance of trial trenching to inform the Development Consent Order (DCO). A detailed WSI was created for Land Parcels 6, 8, 9, 10 and 36 prior to the trial trenching (WSI 1, Oxford Archaeology 2020), which detailed the archaeological background and potential within the site. It also set out the archaeological aims and objectives appropriate to the investigation of this land parcel by trenching and described the methodology to be applied. The WSI was approved by Richard Havis, Principal Historic Environment Consultant for Place Services at Essex County Council, prior to the start of the fieldwork. Oxford Cotswold Archaeology was commissioned as Balfour Beatty's archaeological contractor to undertake the evaluation in accordance with the approved WSI and local and national planning policies.
- 1.1.4 The fieldwork in Land Parcels 6, 8, 9, 10 and 36 was completed between 20th August and 7th October 2020. All work followed the MoRPHE Project Manager's guide (Historic England 2015), and the Code of Conduct of the Chartered Institute for Archaeologists (CIfA). The archaeological works adhered to the standards and guidance for archaeological evaluation, excavation and archiving (CIfA 2014a; CIFA 2014b).
- 1.1.5 The work was monitored by Richard Havis of Place Services on behalf of the Borough of Thurrock.

## 1.2 Location, topography and geology

- 1.2.1 Land Parcels 6, 8, 9, 10 and 36 are located between the settlements of East and West Tilbury and adjacent to the hamlet of Low Street (Fig.1) within the county of Essex and Thurrock unitary authority (NGR 566809 178261). This site comprised parts of five land parcels (Land Parcels 6 (south), 8 (south), 9-

10 and 36) located mainly south of the Muckingford Road and north of the London, Tilbury and Southend Railway. The site covers an area of 82.72ha. Land Parcels 6 (south) and 8 (south) are narrow strips adjacent to the Muckingford Road on the north side. Land Parcel 10 is located west of Low Street Lane which bisects the site north to south. Land Parcels 9 and 36 are located east of Low Street Lane and west of the modern part of East Tilbury. Church Road bisects the southern part of the site on an east-west alignment. The site is also bisected by four green lanes including one named Coal Lane.

- 1.2.2 The bedrock geology of the area of Land Parcels 6, 8, 9, 10 and 36 is Thanet Sand (BGS 2019). The superficial geology of the site is mixed, with the majority of the site overlain by Taplow Gravel with a small area of Lynch Hill Sand and Gravel within the southern part of the site and Boyn Hill Gravels within the western edge of the site. There are also two areas of Head Clay that overlie the bedrock geology, one on the north-west along the western slope of a large dry valley, the other at the base of the dry valley in the south-eastern part of the site, running south to the Thames floodplain.
- 1.2.3 Land Parcel 6 (south) is the southern edge of a large arable field, Land Parcel 8 (south) the edge of a smaller arable field. Land Parcel 9 comprises five arable fields, two areas of scrub and woodland and a large pond. Land Parcel 10 forms part of four arable fields within the western part of the site, and also includes a very small part of Condovers Scout Activity centre. Land Parcel 36 forms parts of three larger arable fields at the eastern edge of the site. Within the 1km site buffer the land use is a mixture of agricultural land and urban development associated with the modern part of the village of East Tilbury and also with the hamlet of Low Street. The land in this area had been cut across by the London, Tilbury and Southend Railway, which has altered its historic character.
- 1.2.4 Apart from a very small area on the gravel terrace at the north-west corner of the site, these land parcels are situated on the slopes of a dry valley that runs north to south east of West Tilbury. The western edge of the site is located at c 20m aOD and this decreases to below sea level at the south-eastern edge of the site. The lowest part of the site corresponds with the location of an area of Head Clay. The nearest watercourse to the site is a north-south aligned creek leading from the Thames estuary to the south, which becomes a pond within the southern part of the site. The line of this creek has historically formed part of the boundary between the parishes of West Tilbury and East Tilbury.

## 1.3 Previous investigations

- 1.3.1 There have been several evaluations, a geophysical survey and an excavation within the eastern part of the site. This includes the excavation of a double ring ditch in 1959-60 which was found to be a Bronze Age barrow. The excavation also indicated that the barrow had been partly levelled and reused for domestic activity during the Iron Age.
- 1.3.2 In the early 1990s a pipeline was laid by British Gas passed through the eastern part of the site and close to the excavated Bronze Age barrow. This revealed a middle Bronze Age cremation cemetery, which was excavated as part of this scheme. A number of worked flints were identified elsewhere along

the route, but are not dated any more specifically than as prehistoric (Smoothy 1993).

- 1.3.3 A geophysical survey followed by an archaeological excavation was undertaken in 2005 which included the eastern part of the site (Oxford Archaeology 2005). This evaluation found a Bronze Age settlement east of the current site that was subsequently excavated, and within the site uncovered a number of Roman field systems and a possible area of Roman settlement.

## 1.4 Archaeological and historical background

- 1.4.1 The chronological summary of known archaeology given below is taken from the detailed WSI for Land Parcels 6, 8, 9, 10 and 36.
- 1.4.2 **Palaeolithic.** No Palaeolithic finds have been recovered within the site. A number of Palaeolithic finds have been recorded 0.8km west of the site at Gun Hill and also at Piggs Pit. These find spots are located on the higher ground of the terrace located at the western edge of the 1km buffer.
- 1.4.3 **Mesolithic.** No Mesolithic finds have been recorded within the site. A Mesolithic flint was recorded at Gun Hill west of West Tilbury (0.8km west of the site).
- 1.4.4 **Neolithic.** In c 1972 Neolithic and Bronze Age flints were identified within the eastern part of the site. These flints may be associated with several ring ditches in this area (discussed in the Bronze Age section below).
- 1.4.5 Flints of late Neolithic or early Bronze Age date came from Gun Hill located 0.8km west of the site. Two Neolithic arrowheads were recorded 0.5km south east of the site and a Neolithic axe head was found 0.8km north of the site in the Mucking Creek valley.
- 1.4.6 **Early to middle Bronze Age.** Three barrows and a trackway are located within the eastern part of the site. Information from the Historic Environment Record (HER) indicates that the central double ditched barrow and largest of the three was excavated in 1959-60 (Bannister 1961; 1962). Several trenches were placed across the ditches and the central part of the barrow. No trace of a possible mound or banks associated with the ditches was found during the excavation and this may be partly due to truncation from arable farming. Both the inner and the outer ditches were recorded as 0.5m deep and human cremated bone and a few small pieces of pottery were recorded in the ditches. A cylindrical cairn or cist of large pebbles was found in the centre of the barrow and it contained an inverted urn over a saddle quern. The urn contained the calcined bone of an adult and a child and a faience bead and metalwork. The cremated bone was radiocarbon dated to 1740-1610 cal BC (GrA28939; 3365±40 BP) (Sheridan 2008, 58). This dates the barrow to the end of the early Bronze Age (or just possible the start of the middle Bronze Age). Two smaller ring ditches located adjacent to the larger barrow were identified as cropmarks in 1980, although one of these was incomplete. A curved trackway was also located next to the ring ditches.
- 1.4.7 The Hordon to Coalhouse Gas Pipeline scheme passed through the eastern part of the site on a NW-SE alignment. A cremation cemetery was identified c 50m south of the large barrow and was also located within the eastern part of the site (Smoothy 1993). Four urned and two unurned cremations were



recorded and one of these was recorded within a pit lined with flints, similar to the cairn within the double ring ditch. Pottery from three of the urns was dated to the middle Bronze Age and the fourth possibly to the early Bronze Age, although this urn was very fragmentary. One piece of unburnt human bone was also recorded, suggesting that an inhumation burial was formerly present. These cremations could be associated within the nearby Bronze Age barrow. The aerial survey identified a number of possible pits south of the large ring ditch, which might also be related to the cremation cemetery (Aerial Mapping Report site 40A).

- 1.4.8 The Hordon to Coalhouse Gas Pipeline also identified a number of worked flints along the route. Two of these were found within the eastern part of the site. These flints were not specifically dated in the HER.
- 1.4.9 Two large adjacent circular or penannular ring ditches located immediately north-west of the site are visible on aerial photographs (Aerial Mapping Report site 26). This is part of an extensive cropmark complex (Aerial Mapping Report sites 53, 24B, 73, 74 and 26) that runs along the edge of the dry valley between Chadwell St Mary and Linford. These ring ditches, which are approaching 40m across, may be large Bronze Age barrows, or possibly earlier prehistoric monuments. Further cropmarks of ring ditches in the vicinity were located east and west of Blue Anchor Lane and Hoford Road within the western part of the study area.
- 1.4.10 In 2005 an evaluation was undertaken across much of Land Parcel 36 and was followed by excavation of two areas adjacent to the site on the east (Oxford Archaeology 2016). The excavation identified a late Neolithic/Early Bronze Age (c 2500-1700 BC) double enclosure consisting of a sub-square annular ditch with a sub-rectangular annex attached to the west side, together measuring 11m x 15m (Oxford Archaeology 2005). A single cremation was found within the sub-rectangular enclosure and was dated to 1750-1530 cal. BC (Oxford Archaeology 2016). The radiocarbon date from the enclosure is similar to that from the cremated bone from the barrow, ie the end of the early Bronze Age or the start of the middle Bronze Age.
- 1.4.11 The excavation also located three larger enclosures, two of which produced middle Bronze Age finds, the third middle-late Bronze Age pottery and other finds. The first enclosure lay west of the early Bronze age double enclosure, was trapezoidal and open on the east side, and contained several groups of middle Bronze Age pits. The southern enclosure was oval and had two trackways extending south-east and SSE from it. There were no internal features, but just to the south were three small circular enclosures, one annular and dated to the middle Bronze Age, the other two penannular and undated.
- 1.4.12 The third middle Bronze Age enclosure lay just south of the early Bronze Age monument and north-east of the oval enclosure, with a ditch extending ENE from the oval enclosure towards its south-west corner, suggesting that they were linked. This last enclosure had a large, trampled working surface within it, together with pits and a possible 6-post posthole building. Unaccompanied cremations were found in the north-west part of the excavation area (closest to the site), but these may have been of later date.

- 1.4.13 **Late Bronze Age and Iron Age.** The excavation of the Bronze Age barrow in the eastern part of the site also found remains of levelling and later occupation deposits containing pottery, burnt clay and wood. The pottery was thought to date to the Iron Age. The aerial survey identified a linear feature projecting south-east of the concentric barrow and it is possible that this feature could indicate a later use of the barrow as a marker during the Iron Age (Aerial Mapping Report site 40A).
- 1.4.14 A sub-square cropmark enclosure is evident within the centre of the site and located on the east side of the dry valley (Aerial Mapping Report site 41A). This enclosure is located next to several circular cropmarks and appears to be associated with linear features, one of which could be a NW-SE aligned trackway. The sub-square enclosure may have been associated with a system of rectilinear fields or enclosures running NNE-SSW along the gravel terrace and up to the edge of the dry valley on its east side (Aerial Mapping Report sites 41B and 43). This group of cropmarks may be of later prehistoric or Roman date.
- 1.4.15 In 2010 an evaluation at Mill House Farm located immediately north-west of the site found evidence of a late Bronze Age/Iron Age settlement. Features recorded included ring ditches, gullies, enclosure ditches pits and postholes. The excavation recovered 84 sherds of pottery dating to the late Bronze Age to early Iron Age (Schofield 2010). This site has subsequently been excavated but not yet published. The interim results of the excavation (Archaeological Solutions 2016) include a dense site of late Iron Age date with a number of enclosures, cremations, ring ditches, smelting pits and over 8000 sherds of pottery (Andy Peachy pers. comm.). Two Late Bronze Age cremations were also found in the Oxford Archaeology excavation just east of the site.
- 1.4.16 A Bronze Age field system and an Iron Age settlement that continued into the Roman period was excavated at Gun Hill Farm located 0.8km west of the site. During this investigation another cropmark enclosure nearby of probable Iron Age date was observed, cut by a late Iron Age or early Roman trackway (Drury and Rodwell 1973). The latter enclosure lay just south of Linford Road, and an Iron Age trackway has been recorded 0.6km west of the site and north of Linford Road. An Iron Age sub-rectangular enclosure was also excavated 1km south-east of the site whose occupation deposits contained Iron Age pottery.
- 1.4.17 **Roman period.** Roman sites have been identified either side of the Muckingford Road, which it has been suggested may follow the line of a former east-west Roman road. This road bounds and bisects the northern part of the site, and if genuinely Roman, may have continued eastwards to join another proposed Roman road believed to have run NW-SE past East Tilbury to a crossing point over the River Thames.
- 1.4.18 A geophysical survey and subsequent archaeological evaluation (Oxford Archaeology 2005) recorded evidence of Roman activity within the eastern part of the site. This included a rectilinear field system and possible settlement activity with ditches orientated NW-SE and NE-SW. Two of the ditches in Trenches 175 and 181 may have represented a driveway. In addition, a possible gravel surface, pits and postholes were recorded in Trenches 178, 189 and 206, which may represent a roadway and part of a settlement. The pottery from these features indicated a date range starting in the 1st century

and concentrating in the late 2nd and early 3rd centuries. The remains of charred grains and chaff identified in soil samples from features in Trenches 168 and 206 provide evidence for the processing of crops in this area (Oxford Archeology 2005).

- 1.4.19 A rectilinear enclosure, a trackway and a number of pits are recorded immediately north-east of the site by the HER and the aerial mapping survey (Aerial Investigation and Mapping Report 39). The evidence from the 2005 evaluation has been compared with evidence from the aerial survey and Trenches 178 and 189 are located in the vicinity of the rectilinear enclosure (493). This suggests that this enclosure may be of 1st-3rd century date.
- 1.4.20 Possible Roman sites and Roman findspots have been recorded within the site and south of Muckingford Lane, the proposed east-west Roman road. The aerial mapping survey identified a NE-SW aligned rectangular enclosure in the centre of the site. Roman pottery of 2nd century date has been found within this enclosure (Aerial Investigations and Mapping Report site 41A), though not directly from the enclosure ditch. This could be associated with a nearby NW-SE linear feature to the west, possibly part of a trackway. Further undated enclosures and trackways have also been identified within the southern part of the site to the east and west of Low Street Road. A walkover of this area as part of the scheme in 2019 recorded a coarse and angular roof tile (1854) in this area, probably Roman in date (Aerial Investigations and Mapping Report site 41B, 43).
- 1.4.21 Several Roman sites and findspots have also been identified close to the site. During the construction of the London, Tilbury and Southend Railway in the mid-19th century a Roman cremation cemetery containing at least three urns were found immediately south of the site. At least three Roman cremation urns were found. One was gifted to the Essex Archaeological Society in 1863, one to Colchester Museum and the third may be in the British Museum.
- 1.4.22 A cluster of Roman activity was recorded during gravel extraction at Condovers Pit located immediately west of the site and south of Church Road. This includes a findspot of 2nd century pottery found in the spoil of the gravel pit. Salvage recording of a Roman updraft pottery kiln was also undertaken here in 1985, finds from which are in Thurrock Museum. A further early Roman kiln site and later agricultural settlement was excavated nearby at Gun Hill some 0.8km west of the site.
- 1.4.23 In 1910 several inhumation burials were found close to the southern edge of the site, although the exact location is unknown. The individuals wore iron and bronze bracelets dated as Roman. PastScape places these burials within Condovers Pit on the edge of the slope of the terrace and close to the site, whilst the Essex HER places these burials on the Thames in a low-lying area 0.5km further south-west.
- 1.4.24 Several rectilinear enclosures and enclosure systems are visible as cropmarks along the east edge of a valley 0.1-1.5km north and north-east of the site (Aerial Mapping Report sites 25, 44 and 45). These may have been Roman rather than Iron Age, or have continued in use in the Roman period.

- 1.4.25 A number of 'red hills' or salterns have been found with associated Roman pottery within the marshlands, located 0.9m south-east of the site. A Roman lamp was also found in the marshland 0.8km south of the site.
- 1.4.26 **Medieval period.** A series of sunken-featured buildings and other features of Saxon date were found at Mill House Farm just north-west of the site, indicating a substantial settlement (Place Services 2019). This site was excavated by Archaeological Solutions in 2017, but is not yet published.
- 1.4.27 Saxon activity was also identified 0.8km west of the site at Gun Hill. A series of aerial photographs taken of this area in the 1950s and 1960s identified a number of pit-like cropmarks that could have represented sunken feature buildings, and some of these were excavated in 1968 and 1969-70 in advance of quarrying. These excavations found a main north-south ditch, flint nodules suggesting a low wall, postholes, silhouettes of timbers, a hearth, animal bone, a bone implement, a loom weight and Saxon pottery.
- 1.4.28 The Saxon settlements at Gun Hill and Mill House Farm lie in the area of three manors in East and West Tilbury that are mentioned in Domesday. They may perhaps have been part of the same dispersed settlement that formed part of one manor, although they may have had no direct connection with the later, 11th century settlements. Domesday notes that in 1086, East and West Tilbury had 16 householders within three different manors. The largest of these was owned by Swein of Essex in 1086, and this had 14 householders, six plough teams, pasture for 300 sheep, woodland and a fishery. The other two land holdings only had one householder each and were owned by William of Warenne and Theodric Pointel (Palmer 2019).
- 1.4.29 The parishes of East Tilbury and West Tilbury were probably formed during the later medieval period and may have originally been associated with two separate manors, West Tilbury Hall and East Tilbury Hall. Part of the boundary between the two parishes is defined by a creek aligned roughly north to south in the south-eastern part of the site.
- 1.4.30 The medieval West Tilbury manor house may have been located in the vicinity of the 17th century West Tilbury Hall and associated 16th century barn 500m west of the site. The medieval East Tilbury Hall (later East Tilbury Place) may have been located north of Love Lane and the Coal Road, c 700m south-east of the site. There was one other medieval manor in West Tilbury, which was Condovers, located south of the junction of Low Street and Church Road and adjacent to the site. This Grade II listed 15th century house is now known as Walnut Tree Cottage.
- 1.4.31 There were five other medieval manors in East Tilbury including St Clere's, Gobyons, Gossalyne and Southall. The manor of Gossalyne later became Goshems and this manor was located west of the Coal Road and north of station road, c 690m south-east of the site (Kemble 2013, Kemble 2014). In the later medieval period the majority of the site was probably used as agricultural land associated with the settlements of Condovers, Goshems, East Tilbury Hall and West Tilbury Hall.
- 1.4.32 Aside from Condovers and the Church of St James there is one other medieval listed building in the study area. This is the Grade II\* listed Marshall's Cottages

located 0.6km west of the site and west of Blue Anchor Lane. This is an early 15th century hall house with cross wings.

- 1.4.33 The later medieval settlements in the area of the site may have been focused around West Tilbury and Low Street. The Church of St James in West Tilbury is located 0.6km west of the site and dates from the late 11th or early 12th century. Earthworks located west of this church have been scheduled and this may be the location of the medieval village of West Tilbury. Medieval pottery was also found nearby during the excavation of Condovers Pit just west of the site and there may be further medieval activity in this area. This pit is located just west of the 15th century house of Condovers (now Walnut Tree Cottage). This suggests that the hamlet of Low Street located adjacent and west of the site may have later medieval origins and there may have been further settlement activity along Church Road. Church Road may have continued as Station Road leading to East Tilbury in the later medieval period. Cropmarks of a rectilinear enclosure which is parallel to Station Road have been identified 0.5km south-east of the site. This may represent the site of a later medieval or early post-medieval farmstead.
- 1.4.34 The former marshland area located directly south of the site contains evidence for a number of co-axial ditches and earthworks of north-south aligned trackways. The co-axial field boundaries are almost certainly former field boundary ditches of possible medieval or post-medieval date. A system of drainage would have been essential to use the low-lying area for pasture. The trackways appear as earthworks consisting of ditches on either side of central tracks visible for over 1.5 km. Four of these trackways are visible running in a north-south direction across the former salt marsh (Aerial Investigation and Mapping Report sites 58, 60). It is possible that these tracks were possible droveways of medieval or post-medieval date. It is possible that Low Street Road which bisects the site on a north-south alignment may have originated as a droveway of later medieval or earlier date.
- 1.4.35 The Map of Essex 1777 by John Chapman and Peter Andre may indicate the medieval road layout and settlement pattern in this area. This map shows Muckingford to East Tilbury Road, the Chadwell to Muckingford Road located at the north end of the site, Low Street Road, Coopers Shaw Road, Church Street/Station Road and the Coal Road. Coopers Shaw Road is located adjacent to the south-western part of the site. The Coal Road is now just a farm track and it bisects the site on a north-west to south-east alignment. It is possible that the Coal Road is of some antiquity and it could have defined the boundary between the medieval manors of East Tilbury Hall and Goshems (Bigley 1982). In addition the north-south creek may have defined the boundary between Goshems/West Tilbury Hall and Condovers.
- 1.4.36 Cropmarks of drainage ditches and earthworks have been noted within the south-eastern edge of the site on aerial photographs but these may have been destroyed by later quarrying and the creation of a pond. It is possible that these earthworks may have been medieval or post-medieval in date and may have been built to mitigate the effects of the creek flooding.
- 1.4.37 **Post-medieval period.** There are a number of 17th-19th century post-medieval listed buildings in the vicinity of the site, although not within the site itself. The closest of these is the 17th century or earlier Grade II listed

Polwicks, adjacent to the site and just east of Low Street Lane. The 17th century West Tilbury Hall is located 500m west of the site. A number of other post-medieval listed buildings are located in the village of West Tilbury and along the Muckingford Road.

- 1.4.38 During the post-medieval period the majority of the site was in use as arable fields associated with several manors in the parish of East and West Tilbury. The majority of the fields within the site western part of the site belonged to the wife of Edward Henry Moore Kelly, a trustee of Jackson King and Thomas Hunt of West Tilbury Hall. A number of fields also belonged to Dr John Scott who owned Polwicks (West Tilbury Tithe map of 1836 D/CT 360). The eastern part of the site (in the parish of East Tilbury) comprised fields that were subdivided into a number of owners including John Radcliffe who owned Goshems, Richard Turner of East Tilbury Place, White Chapel Charity and several others (East Tilbury Tithe map 1839 D/CT 359). During the later 19th and 20th century most of the field boundaries shown on the tithe maps were removed to create larger arable fields. Several field boundaries were plotted by the aerial survey although there were a much larger number of these, particularly in the eastern part of the site.
- 1.4.39 The Map of Essex 1777 by Chapman and Andre shows that there was a post-medieval windmill located c 0.2km west of the site at the junction of the Muckingford Road and Blue Anchor Lane. This map also shows that the Coal Road (which bisects the site) was a major highway linking Chadwell with East Tilbury. The importance of this road diminished in the later 19th century and by the 20th century it had become a farm track. Part of the reason for its decline may have been the construction of the London, Tilbury and Southend Railway which was constructed in the mid-19th century. This railway line defines the southern boundary of the site and it bisects the farm track, although there is a rural crossing at this point. The Low Street railway station associated with this railway was located adjacent and south of the site. Modern satellite imagery indicates that this station has been demolished. The OS map of 1923 indicates that there were sidings and outbuildings associated with this station. East Tilbury Station located 0.4km east of the site was constructed in the 1930s to serve the expanding village of East Tilbury.
- 1.4.40 The 1839 tithe map of East Tilbury indicates that there was an extensive area of gravel pits within the south-eastern part of the site and further south. The part of this gravel pit in the area of the site was owned by West Tilbury Hall. Gravel extraction continued in the 20th century. In the 19th century and early 20th century there was also a large gravel pit just west of the site at Condovers.
- 1.4.41 A brickworks was located to the east of the hamlet of Low Street and 200m from the site on the south-east side. This was active from the early 1900s until 1967, although it was closed during the 1910s-1920s. The sidings that branched off from the London, Tilbury and Southend Railway just outside the site may have been constructed to serve this brickworks and gravel workings.
- 1.4.42 During the Second World War a number of anti-invasion defences were installed in the vicinity of the site but not within the site itself. These include several Alan-Williams Turrets, road barriers and Spigot Mortar sites. There

were also anti-glider ditches that were created just south-west of the site. An Anti-Aircraft battery was also located 0.9km south-east of the site.

- 1.4.43 The settlement of East Tilbury expanded rapidly after the 1930s when the Bata Shoe Factory was set up. The factory was associated with a model settlement located east of the site. The settlement of East Tilbury now extends as far as the eastern edge of the site. A number of the building belonging to the factory and model village have recently been listed.
- 1.4.44 **Undated features and cropmarks.** There are a number of finds and cropmarks within and in the vicinity of the site that are of unknown date. Within the site, the cropmarks east of Low Street Road include a sub-rectangular enclosure discussed above as potentially being of later prehistoric or Roman date. The cropmarks of field boundaries and trackways in the south-western part of the site may also be of the same period. In addition the cropmarks of possible pits south of barrow within the site remain undated, although several pits excavated close by in 1993 were found to be Bronze Age cremation pits.
- 1.4.45 In the wider 1km buffer there are a large number of undated cropmark sites located on the higher terrace towards the north-west of the study area. A large number of cropmarks have also been identified on the terrace to the west of the study area and east and west of Hoford Road and Blue Anchor Lane including a ring ditch, features near Gun Hill, another trackway and ditches. There is also evidence of cropmarks to the north-east and a rectilinear enclosure and pits south east of the site. It is likely that many of these undated cropmark sites will prove to date to the later prehistoric or Roman period.

## 2 Project Aims

---

### 2.1 General aims

2.1.1 The general aims of the project were as follows:

- i. To establish the presence or absence of archaeological remains along the line of the scheme, and the extent of any areas where remains appear likely to be absent.
- ii. In areas where archaeological remains are known or suspected, to clarify the reliability of the cropmark or geophysical survey evidence.
- iii. In areas where no archaeological remains are indicated by aerial or geophysical survey, to clarify whether this apparent absence of remains is genuine.
- iv. To determine the degree of complexity of any surviving horizontal or vertical stratigraphy, and in particular, to investigate areas where topography indicates the likelihood of deep deposit sequences for evidence of buried archaeological horizons and palaeoenvironmental sequences.
- v. Where remains are present, to determine the period(s) represented, the extent, state of preservation and character of the archaeological remains.
- vi. To establish the range and state of preservation of archaeological artefacts, and through their recovery and examination, to establish the potential for information about the economy, status and contacts of past inhabitants of the scheme footprint.
- vii. To determine whether palaeoenvironmental remains are preserved, and, where these are found, to determine their types (e.g. charred plant remains, waterlogged remains, molluscan remains), state of preservation and potential for environmental information. This will be achieved through the recovery of samples from sedimentary sequences and archaeological features suitable for assessment of a range of palaeoenvironmental remains (e.g. charred and waterlogged plant remains, charcoal, insects, pollen, diatoms, ostracods/foraminifera and molluscs) and scientific dating (e.g. radiocarbon and OSL dating).
- viii. To investigate and record the extent, character and chronology of the sedimentary sequences, in particular those immediately adjacent to and in floodplains, contained within palaeochannels or in dry valleys, and to use the data to refine existing geoarchaeological (predictive) deposit models.
- ix. To place any identified archaeological remains into their local and, where appropriate, regional or national context, and to assess the implications of any such discoveries for our current understanding of settlement and landscape change in the area, including an assessment of the associations of any remains with reference to the historic landscape.
- x. To provide sufficient information to enable the LTC archaeological advisor, in consultation with the Key Archaeological Stakeholders, to determine the significance of the archaeological assets identified within the land parcel.



- xi. To provide a report on the discoveries to inform the Environmental Statement (ES) supporting the Development Consent Order (DCO) and support the preparation of a further archaeological mitigation strategy for the Enabling Works and Construction phases of the scheme.
- xii. Following the DCO, to deposit the report in the public domain, and to generate an accessible and useable archive which will allow future research to be undertaken.

## 2.2 Specific objectives

### 2.2.1 The specific project objectives were as follows:

- xiii. To conduct the programme of archaeological investigation within the general research parameters and objectives defined by the revised East of England Research Framework (Medlycott 2011), and to take account of the aims and objectives of the Greater Thames Estuary Historic Environment Research Framework.
- xiv. To clarify through targeting of apparently blank areas whether the cropmarks provide an accurate representation of the range, quantity and types of archaeological features present within the parcel.
- xv. To clarify whether sites or finds of late Upper Palaeolithic or Mesolithic date exist within hollows or on the surface below subsoil in the terrace areas of the site, and if so, to define the date of these (particularly within the Mesolithic period), the extent of any concentrated activity areas and their character.
- xvi. Within dry valley bottoms and sides, to look for buried archaeological horizons and finds scatters within the colluvial (or alluvial) sequence. This is likely to be particularly relevant for sites of the late Upper Palaeolithic, Mesolithic and Neolithic periods, but sites of later periods may also survive buried beneath colluvium or Head deposits, or eroded from upslope.
- xvii. To clarify the potential for well-preserved deposits in these protected locations, whether structural, buried land surfaces with associated activity, or environmental deposits.
- xviii. To investigate activity carried out around burial monuments of the Neolithic and early Bronze Age within the site, whether peripheral burial, deposits related to visits, or reuse for burial or other purposes in later periods.
- xix. To clarify whether the circular ring ditches (the two unexcavated ones) in the eastern part of the site are the remains of burial monuments or 'shrines' of the Bronze Age, and if so, to establish their date and duration of use within and beyond the period.
- xx. To look for evidence of early Bronze Age settlement or other activity in the vicinity of burial monuments or 'shrines'.
- xxi. To clarify the extent and character of activity of the late Bronze Age and Iron Age within the area of WSI I, including whether the occupation found at Mill House Farm adjacent extends into the site, and whether the undated enclosures are of Iron Age origin, and to use both artefactual and scientific dating to assist in establishing whether occupation was long-lasting, repeated or shifting.

- xxii. To establish the extent, character and density of Roman activity within the scheme area, and in particular, whether the undated cropmark enclosures are Roman, and if so, establish their duration of use.
- xxiii. To clarify whether Roman burials exist within the site, and if so, to establish whether these are inhumations, cremations or both, and to clarify their extent and to date and characterise these (using artefactual and/or scientific dating).
- xxiv. To determine whether further evidence of Roman pottery production is present within the scheme area, and if so, to date and characterise this. To look for evidence that might support or deny the existence of Roman routeways on the line of the Muckingford road.
- xxv. To establish the character and date of the pits across the eastern part of the site, and to determine whether these are all of one type or period, or whether they encompass several types and span several periods of activity.
- xxvi. To establish the date of the possible medieval or post-medieval field boundaries that have been identified within the site.
- xxvii. To establish whether medieval droeways extended through the site down to the marshland to the south and east.
- xxviii. To look for evidence of medieval and post-medieval farmsteads that may have been located along the roadways within the site.

## 3 Methodology

---

### 3.1 Constraints

- 3.1.1 Several constraints limited the area of the site available for trial trenching. These included live services and irrigation pipes, crops, ecological constraints and a groundwater flood risk zone.
- 3.1.2 These limitations were considered when designing the detailed trench layout, but the plotted positions of buried services were only approximate, and due to this and low-hanging overhead cables, it was necessary to adjust the locations of approximately 25 trenches in the field. The final trench locations are shown in Figures 2, 3, 4 and 5. However, it was not possible to relocate Trenches 59-61, 124-126, 153 and 187-189. These were consequently removed from this phase of works following discussion and agreement with Richard Havis.

### 3.2 Methodology for the evaluation

- 3.2.1 The total land parcel area was 82.72ha. Much of the eastern part of the site (totalling just under 23ha) had already been investigated by archaeological evaluation trenching and excavation, and this was not examined again. Of the remaining 59.8ha, the area available for investigation excluding areas of services, hedgerows and other constraints was 37.33ha. During the current evaluation, a total of 230 trenches were excavated, with 228 trenches measuring 30m x 2m, one trench (Trench 109) measuring 50m x 2m and one trench (Trench 221) measuring 25m x 10m. Combined, these represent a 3.95% sample of the area available for trenching. The overall location of all trenches is shown on Figure 2.
- 3.2.2 The trench design was developed to target cropmark features identified by the aerial investigation and mapping report (Place Services 2019), and otherwise to provide even coverage of the blank areas. Trenches 107, 109 and 110 targeted a possible sub-rectangular enclosure identified as a cropmark. Trench 109 also targeted a possible ring ditch cropmark, to the immediate south-west of the enclosure. Trenches 58, 107, 109, 110, 128 and 221 targeted possible discrete features detected as cropmarks (Figs. 2, 3, 4 and 5).
- 3.2.3 All trenches were located using a Global Positioning System (GPS) prior to machine excavation. All trenches were excavated using a tracked excavator fitted with a toothless bucket under constant archaeological supervision.
- 3.2.4 Revealed features were hand cleaned and sampled by hand excavation. They were recorded as outlined within the approved WSI. All finds were bagged by context throughout the evaluation and were recovered for further investigation, and soil samples were taken as appropriate

## 4 Results

---

### 4.1 Introduction and presentation of results

- 4.1.1 The results of the evaluation are presented below and include a stratigraphic description of the trenches that contained archaeological remains. The full details of all trenches with dimensions and depths of all deposits can be found in Appendix A. Finds and environmental data are presented in Appendices B and C.
- 4.1.2 Context numbers reflect the trench numbers, unless otherwise stated. The first numerals of a context number repeat the trench number whilst allowing for a maximum range of 100 individual records for any one trench. For example, ditch 803 is a cut within Trench 8, while pit 16802 is a cut within Trench 168. Also Trench 8 has a potential record number range of 800-899, while Trench 168 has a range of 16800-16899.
- 4.1.3 An overview of the results for the site is shown on Figures 2, 3, 4 and 5. Further detailed plans of the trenches which contained archaeological features and associated sections are shown on Figures 6-25. A geoarchaeological transect depicting the recorded sediment sequence is shown on Figure 26.

### 4.2 General soils and ground conditions

- 4.2.1 The soil sequence encountered across the site generally comprised natural geology of sandy gravels, overlain by subsoil and ploughsoil, although in some trenches the natural substrate was directly overlain by the ploughsoil. Colluvial layers were recorded in Parcels 9 and 10, in the dry valley that crosses the central part of the site. In Trenches 155, 156, 157, 159 and 160 the natural geology was overlain by a deposit of made ground at least 0.8m deep in places. This had presumably been laid down to help raise an area of low-lying land deemed to be a flood risk.
- 4.2.2 Due to a lack of rain throughout much of the fieldwork the ground conditions were extremely dry and dusty. This made archaeological features particularly difficult to identify and meant that it took a long period for some features to weather out.

### 4.3 General distribution of archaeological deposits

- 4.3.1 Archaeological features were revealed in Trenches 7, 8, 17, 20, 35, 36, 49, 53, 58, 63, 64, 73, 77, 81, 87, 98, 106-110, 115-118, 120-123, 128, 135, 142, 144, 145, 147, 152, 158, 159, 161, 162, 168, 169, 171, 173, 175, 182, 183, 185, 193, 199, 200, 205, 211, 214, 216, 220-222, 225, 233, 237, 238 and 240. These trenches are discussed in detail below. The rest of the trenches were devoid of archaeological features and are not discussed any further or illustrated in detail.
- 4.3.2 The evaluation confirmed the presence of several linear and curvilinear features within the site that had been identified as cropmarks by the aerial investigation and mapping report (Place Services 2019). The identified features comprised ditches and pits.

## 4.4 Trenches 7, 8, and 220-2 (Figs 6 and 8)

- 4.4.1 These trenches were located in the north-western corner of the site, to the immediate north and south of Muckingford Road, within Parcels 6, 8 and 10. Trenches 220 and 221 were targeted upon the south-eastern edge of a large cropmark complex that extends to the north-west of Parcel 6.
- 4.4.2 **Trench 7** was located east of blank Trenches 3-6 and immediately to the south of Muckingford Road. N-S orientated linear feature 703 was revealed in the eastern part of this trench. It was 1m wide and 0.32m deep, with a single fill (virtually indistinguishable from the subsoil) that contained a single sherd of late Roman pottery. This feature was interpreted on site as a furrow filled with subsoil, although no others were observed in this or adjacent Trenches 3-6. Feature 703 did not correspond to a cropmark.
- 4.4.3 **Trench 8** lay to the south-west of Trench 7, south of blank Trench 4, and revealed a narrow ditch (803) aligned NW-SE that was 0.5m wide and 0.32m deep, with a single fill from which no finds were recovered. This ditch did not correspond to a cropmark, and is not aligned on any of the cropmark ditches to the north-west.
- 4.4.4 **Trench 220** was located north of Muckingford Road in Parcel 6, and was placed to cross a linear cropmark orientated NNW-SSE. It revealed three ditches, one (22005) corresponding to the linear cropmark, and two pits. Ditch (22005) measured 2.82m in width and was excavated to a depth of 0.54m, but was not bottomed (Figure 8, section 22001; Plate 1). It contained two fills caused by natural silting, neither of which produced finds. Ditch 22008 ran parallel to ditch 22005 to its immediate east, but did not intercut. It was 1.33m wide and 0.13m deep, with a single fill that contained no finds. A circular pit lay to either side (22003 to the west, 22010 to the east), both 0.8m across and surviving less than 0.1m deep with a single fill. A broad but shallow ditch 22012, aligned WNW-ESE, crossed the east end of the trench, and this had a single fill. None of these features contained finds.
- 4.4.5 **Trench 221** lay to the west of Trench 220, and was a larger area designed to investigate one linear cropmark orientated NW-SE and several discrete cropmarks. It revealed two parallel ditches, the more easterly of which corresponded to the linear cropmark. Two interventions were cut across these ditches, which were numbered 22106=22109 and 22104=22111. Both ditches were 0.7m wide, and they were 0.15m and 0.23m deep respectively. These ditches contained single fills that yielded no finds.
- 4.4.6 Two of the discrete cropmarks corresponded broadly to soilmarks in the surface of the natural, and these (22103 and 22108) were tested by hand-excavation, but both proved to be of geological origin. The other discrete cropmarks did not correspond to any geological or archaeological features.
- 4.4.7 Ditches 22005, 22106=22109 and 22104=22111 displayed a very good correlation with the cropmarks targeted by Trenches 220 and 221, representing rectilinear enclosures clearly visible as cropmarks forming the south-eastern edge of a large cropmark complex.
- 4.4.8 **Trench 222** located to the east of Trench 220 featured a sequence of deposits that comprised ploughsoil, subsoil, and two colluvial layers overlying the natural geology. The two colluvial layers (22202 and 22203) produced 9 flint

flakes and blade-like flakes and 16 small sherds of flint-tempered pottery. NNE-SSW orientated ditch 22207 was cut into colluvium 22202 (Figure 8, section 22201, Plate 2), and measured 1.32m wide and 0.36m deep with two fills, the upper of which (22208) yielded 14 small sherds of flint-tempered pottery and six flints, including two blade-like flakes. Ditch 22207 truncated an earlier tree-throw hole (22205), also cut through colluvium 22202, from which 12 small sherds of flint-tempered pottery and a single well-struck flint flake were recovered. The struck flint from this trench was described as early prehistoric character, but the pottery was given a provisional date of the middle-late Bronze Age. This indicates either that an early Neolithic knapping scatter had been redeposited by colluvial activity in the later Bronze Age, or that the pottery was in fact early Neolithic. As the pottery was all of the same fabric, it is possible that the material from within the features is residual.

- 4.4.9 **Trench 223** contained only a single soilmark, which was tested by hand-excavation, but proved to be of geological origin.

## 4.5 Trenches 17 and 20 (Figs 7 and 8)

- 4.5.1 Trenches 17 and 20 were located within a block of trenches in Parcel 10, just south of Muckingford Road and west of Low Street Lane. There were no cropmarks in this part of the site.

- 4.5.2 **Trench 17** revealed two parallel NW/SE orientated ditches (1703 and 1705). The more westerly ditch (1703) was wider, and this was excavated. It measured 0.95m wide and 0.42m deep, and contained a single fill that produced no finds. The projected line of this ditch passed between Trenches 22 and 21 to the south, but no continuation of ditch 1705 was seen in Trench 21.

- 4.5.3 **Trench 20** lay to the south/east of Trench 17 and revealed a single NE/SW ditch (2003) in its central part. Ditch 2003 was 0.7m wide and 0.22m deep (Figure 8, section 2000). Two tiny fragments of Bronze Age pottery were retrieved from its single fill.

- 4.5.4 No continuation of ditch 2003 was seen in either Trench 24 or Trench 23 to the south-west.

## 4.6 Trenches 35 and 36 (Fig. 3)

- 4.6.1 These two trenches were located close to the western edge of the site in a block of trenches in Parcel 10. The same E-W orientated ditch (3503 and 3603) was revealed in both trenches. In Trench 35 ditch 3503 was 1.1m wide and 0.44m deep, but in Trench 36 ditch 3603 was only 0.7m wide and 0.12m deep.

- 4.6.2 These ditches contained single naturally silted fills from which the only artefactual material retrieved was a single flint from ditch 3505 and a rectangular iron plate from ditch 3603. The flint is residual, and the iron plate cannot be closely dated, but may be post-medieval, as both ditches lay on or adjacent to the line of a field boundary visible on historic maps (OA 2020, Fig. 7).

## 4.7 Trenches 63, 64, 73, 77 and 81 (Figs 9 and 10)

- 4.7.1 These trenches lay within in a block of trenches east of Low Street Lane and south of Muckingford Road, in the north-eastern corner of Parcel 9.
- 4.7.2 **Trench 63** revealed a narrow (0.5m wide) NE-SW orientated ditch (6303) that was shallow with a single fill that contained no finds. No continuation of this feature was seen in either Trench 67 or Trench 72 to the south-west, and there were no further trenches to the north-east. A ditch on a parallel alignment, also narrow, was seen in Trench 73 some 65m to the south.
- 4.7.3 **Trench 64** was located east of Trench 63 and contained a N-S ditch (6407) and two circular steep-sided pits (6403 and 6405). Ditch 6407 was 1.9m in width and 0.32m in depth, with a single fill but no finds. The projected line of this ditch passed between Trenches 68 and 69 to the south, but no continuation of this ditch was seen in Trench 74 beyond them.
- 4.7.4 To the west of the ditch, pit 6405 was 0.42m wide and 0.14m deep and yielded a small amount of flint. Pit 6403, of which just over half lay within the trench west of pit 6405, measured 0.59m wide and 0.5m deep. An environmental sample (S. 1) taken from its single fill (6304) produced indeterminate grain, burnt flint, pottery and fired clay. Overall, the fill contained 47 sherds of middle to late Bronze Age pottery and flint flakes (Figure 10, section 6401, Plates 3 and 4). Two substantial fragments of a fired clay portable oven or hearth furniture were also recovered from this fill.
- 4.7.5 **Trench 73** lay south of Trenches 63 and 64 beyond blank Trench 68, and contained one linear feature and two linear soilmarks of geological origin. Ditch 7305 was orientated NE-SW and terminated at the south within the trench. It was only 0.25m wide and 0.12m deep, with a single fill that contained fragmented scraps of pottery that disintegrated on lifting. No continuation of this feature was seen in blank Trenches 68 or 69 to the north and north-east. Soilmarks 7303 and 7307 were tested by hand-excavation, but proved to be natural. Trench 74 to the east also contained only soilmarks of geological origin.
- 4.7.6 **Trench 77**, which lay to the south-west of Trench 73, revealed NW/SE aligned ditch 7703 that measured 1.9m in width and 0.14m in depth and contained a single fill from which 17 pottery sherds of middle to late Bronze Age were retrieved.
- 4.7.7 **Trench 81**, located south-west of Trench 77, contained a circular pit (8103) that was partially exposed within the central part of the trench. Pit 8103 had steep near vertical sides which were slightly undercut and contained a sequence of three fills from which no finds were retrieved (Figure 10, section 8100, Plate 5). Hand excavation was halted at a depth of 1m below present ground level without reaching the base of the pit.

## 4.8 Trench 49 and 53 (Figs 3 and 10)

- 4.8.1 **Trench 49** lay at the west edge of Land Parcel 10 120m south of Trenches 35 and 36. Pit 4903 was exposed towards the east end of the trench, and was 0.76m across and 0.22m deep with a single, sterile fill.

4.8.2 **Trench 53** lay south-east of Trench 49 in the southern part of Land Parcel 10 and was excavated across a linear cropmark aligned NW-SE. Ditch 5302 was 1.14m wide and 0.24m deep (Figure 10 Section 5300) and was revealed in the central part of Trench 53 on a NW-SE alignment, correlating closely to the line of the cropmark. No finds were recovered from the single fill.

## 4.9 Trenches 87 and 98 (Figs 4 and 11)

4.9.1 **Trenches 87 and 98** were located to the south of Trench 81 and were both E-W orientated.

4.9.2 **Trench 87** (which is not illustrated in detail) had one N-S ditch numbered 8703, which was just over 1m wide and 0.24m deep, with a single fill that contained struck flint of Mesolithic or early Neolithic date. This was presumably residual.

4.9.3 **Trench 98** contained two N-S aligned ditches: ditch 9804 was 0.8m wide and 0.22m deep, ditch 9806 was just over 1m wide and 0.4m deep (Fig. 11). Both had single fills that did not produce finds. From their projected lines it is possible that one of the ditches in Trench 98 was a continuation of 8703.

## 4.10 Trenches 106-10, 115-18 and 128 (Figs 11 and 12)

4.10.1 These trenches all lay close to the central part of the site in Parcel 9 and were mainly targeted upon a sub-rectangular cropmark enclosure with a circular cropmark just outside it to the west, and other linear and discrete cropmarks within and surrounding the enclosure. The rectilinear enclosure was tested by Trenches 107, 109 and 110, which exposed ditches on the south-west, north-west and south-east sides of the enclosure corresponding to the cropmark enclosure.

4.10.2 **Trench 106** lay north of the enclosure and west of Trench 107, and revealed an east to west aligned ditch (10603) that had not been detected as a cropmark. Ditch 10603 was 2.05m in width and 0.35m in depth, with a single fill that did not contain any finds.

4.10.3 **Trench 107** was located 30m east of Trench 106, but did not reveal a continuation of ditch 10603, nor was there a feature corresponding to the large discrete cropmark crossed by the north end of this trench. The trench did however locate the NW side of rectangular cropmark enclosure. Ditch 10703 was 1.04m wide and 0.32m deep (Figure 12, section 10700) and was identified near the south-eastern end of Trench 107. It contained two silty fills from which no finds were retrieved.

4.10.4 **Trench 108** was located to the south-west of Trench 106 and revealed a very shallow NW-SE orientated ditch (10802) that terminated within the trench and produced no datable evidence. An irregular linear soilmark (10804) was also tested by hand-excavation, but proved to be natural.

4.10.5 **Trench 109** was located immediately to the south-east of Trench 108 and was laid out as an L-shape to investigate both the interior of the cropmark enclosure and its south-western side and the adjacent circular cropmark. Three ditches and nine pits were revealed in Trench 109, generally providing a good correlation with the cropmarks.



- 4.10.6 Ditch 10910 was revealed halfway along the north-west arm of Trench 109. This ditch was orientated NW-SE, measured 4.86m wide and was excavated to a maximum depth of 0.65m from the top of the natural, but was not bottomed (Figure 12, section 10902, Plate 6). This closely corresponded to the ditch of the rectilinear cropmark enclosure also investigated in Trenches 107 and 110. Ditch 10910 contained two fills, the upper of which (10912) yielded a single fragment of pottery of possible early medieval date and another of either early Romano-British or late Saxon date, together with a flat sherd of fired clay that could be a fragment of an oven plate or a briquetage vessel.
- 4.10.7 South-west of this, ie outside the enclosure, was a curvilinear ditch 10913 that measured 0.7m in width and 0.4m in depth, with two fills (Figure 12, section 10903). There were no finds. Although this lay 5m from the circular cropmark, it is likely that it corresponds to the north-east side of this feature.
- 4.10.8 Within the area enclosed by curvilinear ditch 10913 four pits were revealed including two possible un-urned cremation pits (10917 and 10920). Of these, pit 10917 was fully excavated but pit 10920, which was only partially exposed within the trench, was not tested. Pit 10917 was circular and measured 0.5m in diameter and 0.35m deep with vertical sides and a flat base (Figure 12, section 10906). There were two fills, the lower of which was charcoal-rich and was environmentally sampled (S. 4), producing a large quantity of charcoal, a charred legume and calcined bone. Circular pit 10915 identified east of pit 10917 was 1.2m wide and 0.2m deep and contained a single fill from which no finds were recovered. The fourth pit (10921) was not investigated.
- 4.10.9 Within the interior of the rectilinear enclosure, and in the south-eastern arm of Trench 109, a large possible cut feature (10907) was revealed. It was at least 11.5m wide and contained a sandy silt fill that was excavated to a depth 0.45m but produced no datable evidence. Feature 10907 seems to correspond to a large oval cropmark detected within the enclosure, although the cropmark was plotted 4-5m further north than the revealed feature. Three undated features, NW/SE ditch 10908 and oval pits 10903 and 10905, were cut into possible feature 10907. The ditch was just over 0.8m wide and 0.46m deep, the pits 0.64m across by 0.24m deep and 1.16m wide and 0.42m deep respectively.
- 4.10.10 To the north-west, pits 10925 and 10926 were revealed but were not excavated. The northernmost of the pits (10925) was circular and 0.5m in diameter, and held a complete pottery vessel that was left *in situ* (Plate 7). During the evaluation, a total of 28 fragmented sherds from the vessel were cleaned from the surface and are of later Bronze Age date.
- 4.10.11 **Trench 110** was excavated to target the south-eastern side of the rectilinear cropmark enclosure and a large discrete cropmark just outside. The trench revealed a ditch (11002) that correlated closely with the cropmark. Ditch 11002 was 2.6m wide, had an asymmetrical profile. Hand excavation through ditch 11002 was halted at a depth of 0.6m below the top of the natural without reaching its base, and within this depth there was only a single fill with no finds. No feature corresponding to the discrete cropmark was found.
- 4.10.12 **Trench 103** was moved from its original position and, following a suggestion by Richard Havis, was relocated to investigate the internal area enclosed by the rectangular cropmark enclosure revealed in Trenches 107, 109 and 110 and also to establish the extent and nature of large feature 10907 in Trench

109. The trench did not contain a continuation of feature 10907, showing that it had ended south-west of this, and indicating that the cropmark outline may accurately reflect the size of this feature. No further archaeological features were found in Trench 103, although two natural features were identified in the central part of the trench.

- 4.10.13 **Trench 117** was located to the south-west of Trench 116, and was positioned to cross a linear cropmark aligned NE-SW that turns a right angle just outside the rectilinear cropmark enclosure, and was probably associated with it. It contained a NE/SW ditch (11703) around 1m wide that had been re-cut by ditch 11705, which was 1.3m wide. The ditches were 0.24m and 0.4m deep respectively. Both ditches contained single fills that yielded no finds. The ditches were several metres from the linear cropmark, but almost certainly correspond to it.
- 4.10.14 **Trench 118**, located south-east of Trench 117, revealed a N/S aligned ditch 11803 that was 0.8m wide, 0.37m deep and contained no finds.
- 4.10.15 **Trench 128** was located west of Trench 117, and was targeted upon a large discrete cropmark feature towards its east end. Three cut features were revealed in the area covered by the cropmark. Feature 12808 (Plate 8) was not fully exposed within the trench, extending beyond it to the east. It was 0.3m deep, at least 2.5m wide and contained a sequence of two fills that yielded 9 sherds of later Bronze Age or early Iron Age pottery. This feature is offset from the plotted large discrete cropmark by several metres, but is likely to correspond to it.
- 4.10.16 Just west of feature 12808, two pits (12803 and 12805) were revealed. Pit 12803 was 0.8m wide and 0.12m deep. Pit 12805 was 0.3m in diameter and 0.1m deep (Figure 12, section 12801). No finds were recovered from any of these pits, although pit 12805 contained a lower charcoal-rich fill that was sampled (S. 5) and produced charcoal and burnt stone.
- 4.10.17 **Trench 116**, north of Trenches 117 and 128, was located to cross a long linear cropmark oriented NW-SE. revealed NW/SE aligned ditch 11603 that closely correlated to a linear cropmark visible to the west of the rectangular enclosure. Ditch 11603 measured 0.89m in width and 0.27m in depth and contained a single artefactually undated fill (Figure 12, section 11600). This ditch truncated earlier pit 11605 that yielded no finds, but from which an environmental sample (S. 2) was retrieved. Charcoal and flint were recovered from the sample.
- 4.10.18 **Trench 115** was located east of Trench 118 and south of Trench 110, beyond blank Trenches 114 and 113. It revealed an east-west ditch (11504) at the north end, which was not further investigated, and a narrow NNW-SSE ditch (11502) running down the southern half of the trench, and making a right-angled corner at the north end to continue ENE. Ditch 11502 was only 0.43m wide and 0.09m deep, and did not contain any artefactual material. It is probable that this continues in Trench 122 as ditch 12202.

## 4.11 Trenches 120-3 (Figs 13 and 14)

- 4.11.1 These four trenches were located in Parcel 9, south of Trenches 115 and 118. Three of them (120, 121 and 122) were excavated to investigate a pair of linear cropmarks running NE-SW and ENE-WSW, and Trench 120 was also

located to further investigate the linear cropmark tested in Trench 116 further north (see above). The ENE-WSW cropmark linear was in two parts that were not exactly in line with one another, but were presumably parts one boundary.

- 4.11.2 **Trench 120** revealed two parallel NE/SW orientated narrow, shallow ditches (12003 and 12005), of which the more northerly (12005) corresponded to the linear cropmark. Both ditches were around 0.65m wide and were no more than 0.15m deep, with single fills that contained no finds. No ditch relating to the NW-SE cropmark linear was found, although as the trench ended halfway across this it is possible that a ditch lay just beyond the end of the trench.
- 4.11.3 Running at right angles to ditches 12003 and 12005 was a ditch (12007) mirroring the line of the linear NW-SE cropmark, even to the slight curve towards the south. This ditch stopped short of ditch 12005 on either side, as if respecting it, but crossed ditch 12003, although no relationship between them could be determined. This ditch was not investigated by hand excavation, but suggests that the NW-SE and ENE-WSW linear cropmarks were in use together.
- 4.11.4 **Trench 121**, which lay east of Trench 120, crossed both the ENE-WSW and the NE-SE linear cropmarks. No ditch corresponding to the SW-NE cropmark was found, but two parallel ditches (12102 and 12104) were found further north, which were in line with the ENE-WSW ditches in Trench 120, and are probably continuations. As in Trench 120, the more northerly of these (12102) matched the linear cropmark. These ditches were slightly wider than those in Trench 120, but were still shallow with single fills. No finds were retrieved from either ditch.
- 4.11.5 **Trench 122** was located further east and was again placed to cross both the NE-SW and ENE-WSW linear cropmarks. No trace of a ditch corresponding to the NE-SW cropmark was found, but ditch 12204 corresponded to the cropmark on an ENE-WSW alignment. This was in line with ditches (12104 and 12003) further west, and was probably part of the same boundary. North of this was ditch 12202 which is likely to be the same as ditch 11502 recorded to the north.
- 4.11.6 **Trench 123**, excavated to the south of Trench 122, was not located to target any cropmarks, but exposed a ditch and three pits within its north-eastern part. Ditch 12312 was NW-SE orientated and measured 1.52m in width and 0.18m in depth. This ditch featured a single fill (12313) that contained two sherds of grog-tempered ware of Late Iron Age or early Roman date, as well as some residual sherds of Bronze Age or Iron Age pottery. No continuation of this ditch was seen in Trench 120 to the north-west, and the trenches planned south-east of Trench 123 were not available for excavation.
- 4.11.7 Two metres south-west of ditch 12312 lay intercutting circular pits 12306 and 12308 (Figure 14, section 12301; Plate 9). Pit 12306 was 0.8m wide and 0.58m deep, with steep sides and a flat base, and contained a single fill that produced 12 sherds of middle Bronze Age pottery and fragments of hearth surface made of fired clay. Pit 12308, which truncated earlier pit 12306, was 0.5m wide and 0.32m deep, again with steep or vertical sides and a flat base, and featured a sequence of three fills (12309, 12310 and 12311) that together contained 12 sherds of pottery of middle to late Bronze Age date. Environmental sample (S. 3) was taken from middle fill 12310 of pit 12308 and

contained grain, possibly barley, and burnt flint. To its immediate south, pit 12303 was 0.66m wide and 0.22m deep and contained two fills that produced 19 pottery sherds of middle to late Bronze Age date.

## 4.12 Trenches 132, 134-8, and 140-1 (Figs 15, 22 and 23)

- 4.12.1 These trenches lay west and south-west of Trenches 120 and 123, and were located in a dry valley in the central part of Parcel 9. With the exception of Trench 136, they were excavated up to a depth of 2m to investigate the potential for buried archaeological horizons within the sequence of colluvium. No significant buried horizons or artefact spreads were identified in any of these seven trenches, although a small assemblage of later prehistoric worked flint was recovered from the colluvium in Trenches 137, 138, 140, 141. Further details on the geoarchaeological observations and the potential of these deposits have been included in Appendix C.5.
- 4.12.2 **Trench 136.** This trench lay south-west of Trench 120, and was located to cross the end of the linear ENE-WSW cropmark investigated in Trenches 122-120. No archaeological feature corresponding to the cropmark was found, and the trench was blank.
- 4.12.3 **Trench 140** revealed two ditches sealed beneath the uppermost colluvial layer 14018, which was sterile. With the exception of a thin layer (14007), all of the fills appeared to be sequences of naturally silted material. Ditch 14011 was cut into colluvial deposit 14016 on the south side, and measured at least 0.66m wide and 0.55m deep, with a very steep south side and a rounded base (Fig. 25, Section 14001; Plate 18). Its primary fill (14012) covered the south side and the base, and had a nearly vertical interface with fill 14013 to the north, perhaps suggesting that 14013, and fill 14014 that overlay it, were the fills of a recut. None of the fills contained any finds.
- 4.12.4 Ditch 14011 was truncated to the north by ditch 14004, which cut colluvial deposit 14017 on its north side, and which was 1.7m wide and 0.7m deep, with a vertical south side and a sloping north side (Fig. 25, Section 14001; Plate 18). There were six fills, the primary silting being down the north side (14005) and in the deepest part of the base (14006, following which there was a thin deposit containing frequent charcoal (14007) covering the base and north side. The succeeding main fills (14008 overlain by 14010) were both light blue-grey silts, suggesting that they had formed in wet conditions. They were separated by a lens of sandy material (14009), probably representing collapse from the sides. Deposit 14010, the uppermost fill of ditch 14004, contained two small sherds of late Roman pottery. Colluvial deposit 14017 on the north was a mottled grey-brown and red-brown silt, and contained struck flint of later prehistoric (later Bronze Age) date. Colluvial deposit 14016 on the south was a red-brown clayey silt, and overlay a thin layer of pebbles and struck flint 14019 with iron staining, the flint also being of later Bronze Age character. It is possible that deposits 14016 and 14017 were parts of one layer, though separated by the ditches. The thin layer 14019 at the base of 14016 was probably a separate deposit, but the flints within it may have been worm-sorted horizon from layer 14016 above, coming to rest on the surface of layer 14019.

- 4.12.5 **Trench 141** was located to the south-east of 140, and revealed a sequence of colluvial deposits, five of which were exposed, and three more augered. The lowest four colluvial deposits exposed were 14111, 14110, 14009 and 14112 in ascending order. Struck flint was recovered from 14111 and 14112, and was of later prehistoric date except for one piece from 14112.
- 4.12.6 Cutting through layer 14112 below the subsoil 14101 was a large ditch or erosion gully, 14103 (Fig. 24; Plate 16). The feature was around 4.5m wide at the top, where the sides splayed out, steepening on the south-west side below the top fills 14102 over 14108, and more gradually on the north-west, where a shelf was covered by middle fills 14107 over 14106, below which both sides were steep. The lowest fills exposed were 14105 over 14104, which was still going down at a depth of 2m, where the feature was still 1.8m wide. A sample for radiocarbon dating (S. 25) was taken from this layer, and yielded heartwood charcoal from field maple and ash, but no short-lived wood. Another sample (S.26) was taken from the augered lower part of the same deposit, but the charcoal was poorly preserved and unidentifiable.
- 4.12.7 Below this the deposit sequence was recovered by augering, and deposit 14104 was another 0.8m deep, which may represent the base of the gully. Struck flints were recovered from fills 14104, 14108 and 14102, and these were of later prehistoric character. The condition of most of the flint was consistent with redeposition in colluvium, except for the group of chips and a flake from 14104, which may have been freshly deposited, perhaps providing an approximate date for the lower fills of the erosion gully.

### 4.13 Trenches 142, 144-5, 147 and 152 (Fig. 16)

- 4.13.1 Trenches 142, 144, 145, 147 and 152 were located south-west of the dry valley occupied by Trenches 132, 134-138 and 141 on the western side of Parcel 9, to the east of Low Street Lane. All but Trench 152 were excavated to investigate linear cropmarks.
- 4.13.2 **Trench 142** was positioned to cross the intersection of a NW-SE and an E-W linear cropmark. An E-W orientated ditch (14203) was found corresponding to the cropmark, but no ditch on a NW-SE alignment was found. The trench also revealed a second roughly E-W ditch (14205) south of 14203, which was not evident as a cropmark. Ditch 14203 was 0.9m wide, ditch 14205 only around 0.6m wide. Both ditches were investigated by hand, and were shallow with a single (very similar) fill, but no finds were recovered from the fills of either ditch.
- 4.13.3 **Trench 144.** This trench lay south of Trench 142 across the line of a NE-SW cropmark. Two ditches were revealed in the central part of this trench on a parallel E-W alignment. Ditch 14403 was 1.2m wide and 0.38m deep and contained a single undated fill (Figure 18, section 14400). Ditch 14405, which lay around 5m to the north, was 2.8m wide but was not further investigated. This ditch corresponded to the location of the linear cropmark, although its orientation was somewhat different.
- 4.13.4 **Trench 145** was located to the west of Trench 144, and also crossed the NE-SW linear cropmark. This trench also exposed the two E-W aligned ditches some 4m apart, straddling the line of the linear cropmark. The more northerly ditch (14502) was 3m wide and was excavated to a depth of 0.56m, but was not bottomed. Two fills were exposed, the lower (14503) a dark organic sandy

silt fill, the upper (14504), which filled the eroded top of the ditch, a light sandy silt with a piece of 19th century CBM on its surface. There was considerable rooting in the lower fill of this ditch. A modern pit (14506) dug to bury a sheep was found just north of ditch 14502. The southern ditch 14505 was 2.7m wide, but was not investigated by hand.

- 4.13.5 The planned alignment of the ditches revealed in Trenches 144 and 145 would suggest that ditch 14403 is continued by ditch 14502, and that no continuation of either 14405 or 14505 was evident in the other trench. It is, however, much more likely that the surface plan of the ditches did not reflect their original alignments, and that ditch 14502 was a continuation of 14405 and 14505 a continuation of ditch 14403. Which of these ditches corresponded to the linear cropmark is unclear, though it is perhaps more likely that it was the more northerly ditch, 14405 = 14502, which may have marked a post-medieval field boundary.
- 4.13.6 **Trench 147** was located south-east of Trench 144, and was positioned to cross three linear cropmarks, two running roughly E-W, the third running NE-SW diagonally between them. All three cropmarks corresponded to ditches. The northern E-W ditch (14703) was 0.6m wide and 0.22m deep with a single, sterile fill, and the southern E-W ditch (14706) was 1.2m wide, but had post-medieval (16th-18th century) brick in its surface, and correlates to a former field boundary depicted on late 19th century historic mapping (OA 2020, fig. 7), so was not further investigated. The NE-SW ditch (14705) was just over 1m wide, with a single sandy fill that did not contain finds. No continuation of either of the E-W ditches was seen in Trench 146 to the west, although it is possible that a continuation of ditch 12406 lies just beyond the south end of Trench 146.
- 4.13.7 **Trench 152.** Trench 152 lay east of Trench 147, and was positioned to see if the NW-SE linear cropmark evident further to the NW continued southwards. No ditch on this alignment was seen, but the trench did reveal a ditch (15203) on a NE-SW alignment at the western end of this trench. It contained a single fill from which no artefactual material was recovered. No features or finds were recovered from Trenches 149, 150 or 151 between Trench 152 and deep Trenches 140 and 141

## 4.14 Trenches 199, 200, 205, 211, 225 and 240 (Fig. 17)

- 4.14.1 These five trenches lay within a block set out to investigate the eastern edge of the site in Parcels 9 and 36, east of the rectilinear cropmark enclosure and west of the railway line. Three trenches (191, 193 and 199) were located to cross a linear cropmark on a NW-SE alignment.
- 4.14.2 **Trench 199** revealed a NW-SE orientated ditch (19903) that corresponded to the location of the cropmark. Ditch 19903 was 0.94m wide and 0.32m deep and had a single fill that did not produce any finds. No ditch corresponding to the linear cropmark was found in either of Trenches 191 and 193. On the west of ditch 19903, pit 19905 was partially exposed in the SE side of the trench. The exposed part was investigated by hand, and was 0.6m wide and 0.19m deep with a single fill but no finds. Several other soilmarks were exposed west and east of the ditch (19907-9), but all proved to be of natural origin.

- 4.14.3 **Trench 200**, which was located to the south-east of Trench 199, revealed a narrow ditch (20002) aligned NE-SW that measured 0.65m in width and 0.15m in depth, with a single fill that contained no finds. This ditch was not evident as a cropmark, but ran on a right angle to the end of the linear cropmark corresponding to ditch 19903, so may have been associated.
- 4.14.4 **Trench 205** lay south-west of Trench 200 and south of Trench 199, and revealed the terminus of a curving ditch (20503 = 20507) on a broadly NW-SE alignment at its west end. The curving ditch was 0.93m wide and 0.51m deep, shallowing at the terminus, but no finds were recovered from its single fill. Just east of the ditch terminal was a possible pit (20505), which was oblong, 1.4m long and 0.14m deep, with a single, sterile fill.
- 4.14.5 **Trench 211** lay south of Trench 205, and contained a pit (21103) that was 0.95m in diameter and 0.15m deep. Part of an iron horseshoe of medieval (12th-14th century) date was recovered from the single loose grey silty sand fill, and an iron nail of uncertain date came from the topsoil in the same trench.
- 4.14.6 **Trench 240** located in Parcel 36 east of Trench 199, revealed two ditches that did not correspond to cropmarks. Ditch 24003, which was recorded in the southern end of the trench running on a NE-SW alignment, was 0.36m wide and survived to a depth of 0.06m. No finds were recovered from the single fill of ditch 24003, but its projected line is close to that of ditch 20002 recorded in Trench 200, and these may be parts of the same boundary ditch.
- 4.14.7 NW-SE aligned ditch 24005 was revealed to the north of ditch 24003 and was 1.3m wide and 0.25m deep (Figure 18, section 24001, Plate 10). Ditch 24005 had a single fill (24006) that produced five sherds of pottery possibly of early Neolithic date, together with a large flint tool representing an end scraper of probable Neolithic date and four flint flakes. The end scraper was the only formal flint tool recovered from the entire site. Fragments of charcoal were also recovered by hand from this fill, and although heartwood may be suitable for radiocarbon dating. To the north, a discrete soilmark (24007) proved to be of natural origin.
- 4.14.8 **Trench 225** was located some 90m south-east of Trench 200 and revealed a NE/SW orientated ditch (22503) that was 0.9m wide and 0.14m deep. A sherd of Bronze Age pottery was recovered from its single fill.

## 4.15 Trenches 168 and 171 (Fig. 19)

- 4.15.1 Trenches 168 and 171 were located in the southern part of Parcel 9, immediately to the east of Low Street Lane, and in an area of the site where no cropmarks had been detected.
- 4.15.2 **Trench 168** was aligned E-W and exposed two pits (16802 and 16804) in its central part. Pit 16802 was circular in plan and measured 1.6m in diameter and 0.6m deep, with sloping sides and a rounded base (Figure 18, section 16800). Its single fill 16803 produced ten sherds of medieval pottery from a decorated cooking pot of later 12th-early 13th century manufacture. Some 2.5m west of pit 16802, pit 16804 was 0.6m wide, 0.3m deep and contained no finds.
- 4.15.3 **Trench 171** was south of Trench 168 and revealed a NW-SE orientated ditch (17102) that was 1m wide, 0.4m deep and contained a single fill that yielded

no artefactual material. No continuation of this ditch was seen in Trench 172 to the south-east.

#### **4.16 Trenches 175, 182-3 and 185 (Fig. 20)**

- 4.16.1 These four trenches were located in the southern end of the site, to the east of Low Street Lane and to the north-west of the train line, in Parcel 9.
- 4.16.2 **Trench 175.** This trench contained a single discrete feature at the north end. Pit 17502 was elongated, 4m long and 1.6m wide, and was investigated at the south end, where it was 0.42m deep with a single fill but no finds (Fig. 21, Section 17500).
- 4.16.3 **Trench 183** was located south of Trench 175 and exposed two soilmarks crossing the full width of the trench (18303 and 18306). The smaller of these (18303) was investigated by hand, and was 1.8m wide and 0.42m deep with sloping sides and a flat bottom (Fig. 21, Section 18300). There were two fills, the upper of which had frequent stone inclusions and produced 11 sherds of pottery of late 15th-16th century date and ceramic building material of 16th-18th century date. The function of these soilmarks is uncertain, but they may have been quarry pits.
- 4.16.4 **Trench 182** lay south of Trench 183, and revealed another large soilmark that may have been a continuation of quarry pit 18306. This was not investigated. The trench also contained an E-W aligned ditch 18203 that was 0.92m wide and 0.4m deep with a V-profile (Fig. 21, section 18200), and contained 16 sherds of post-medieval pottery, ceramic building material of both 16th and 18th centuries including a chimney pot of probable Georgian (18th century) date, a copper alloy sheet with a paperclip rivet dating to the late 15th or 16th century, and animal bone. On its north side it cut feature 18205, which proved to be of natural origin.
- 4.16.5 **Trench 185**, located to the east, also revealed a broadly E-W ditch (18503) on much the same line as ditch 18203, which was not investigated by hand. This may be a continuation of the same medieval ditch.

#### **4.17 Trenches 214 and 216 (Fig. 22)**

- 4.17.1 These trenches lay east of the cropmark rectilinear enclosure on the east side of Land Parcel 9, and south-west of Trenches 191, 193, 199, 201 and 240.
- 4.17.2 **Trench 214** revealed a ditch (21403) aligned NW-SE that was 1.13m wide and 0.32m deep, with a single silty sandy fill, but no finds.
- 4.17.3 **Trench 216** lay south-west of Trench 214, and revealed a single ditch at its west end. This ditch (21601) was aligned NE-SW, was 0.84m wide and 0.16m deep, with a single reddish-brown sandy silt fill, again without finds. No continuation of this ditch was seen in Trench 213 to the north-west, so it must have ended or turned before this.

#### **4.18 Trenches 233, 237 and 238 (Fig. 23)**

- 4.18.1 These trenches lay at the east edge of the site in Land Parcel 36, south of Trenches 201, 205 and 225.



- 4.18.2 **Trench 233** contained a ditch (23303) on a NNW-SSE alignment that was 0.6m wide and 0.08m deep, with a single fill but no finds. No continuation of this ditch was seen in Trench 237 to the south-east.
- 4.18.3 **Trench 237** lay SE of Trench 233, and contained a single small pit or tree-throw hole (23704) 0.3m in diameter but only surviving 0.06m deep. Several sherds of later Bronze Age or Iron Age pottery were recovered from the fill. This trench also contained a soilmark 23703 that proved to be of natural origin.

## 4.19 Finds summary

- 4.19.1 **Prehistoric pottery.** A total of 198 sherds (1028g) of prehistoric pottery were recovered during the evaluation. Most of the material is flint tempered, and the only diagnostic sherds are middle Bronze Age, and (less certainly) late Bronze Age, with a small amount of pottery from Trench 240 of possibly early Neolithic date. Pottery from Trench 220 was too small for certain identification, but was thought more likely to be later Bronze Age than early Neolithic, although the associated struck flint was early Neolithic.
- 4.19.2 **Roman pottery.** Eight sherds of late Iron Age and Roman pottery were recovered from the evaluation. The assemblage comprised body sherds only and no forms could be identified. The pottery points to late Iron Age/early Roman and late Roman activity in the vicinity of the site, and the condition and size of the assemblage suggest that the material had undergone several episodes of redeposition.
- 4.19.3 **Medieval and post-medieval pottery.** A total of 39 sherds of medieval and post-medieval pottery weighing 1634g were recovered from four contexts. The pottery comprises ordinary domestic wares typical of this part of south Essex and includes material of several dates between the early or mid-Saxon period and to the 16th century.
- 4.19.4 **Fired clay.** A small quantity of fired clay amounting to 58 fragments weighing 1927g was recovered from Trenches 64, 109, 123, and 155. The assemblage consists of small and large fragments, some fresh and well-preserved, others abraded and poorly-preserved, with a mean fragment weight of 33g. The assemblage consists primarily of substantial parts of two or more late Bronze Age cylindrical perforated blocks, all from Trench 64.
- 4.19.5 **Ceramic building materials.** Ceramic building material (CBM) amounting to 42 fragments weighing 3196g was recovered from Trenches 122, 145, 147, 182, 183 and 233. The assemblage is all post-medieval, apart from one fragment from Trench 122 that may be either CBM or fired clay, and cannot be dated.
- 4.19.6 **Metals.** Four metal objects (142.5g) were recovered from three contexts. These comprised three iron objects (63.5g) and one copper alloy object (79g). Two of the objects could be broadly dated to the medieval and/or post-medieval period while the remaining two are of uncertain date.
- 4.19.7 **Flint.** A total of 81 worked flints was recovered during the evaluation, alongside 77 fragments of unworked burnt flint. The majority of the assemblage was derived from the colluvial sediments and associated deposits in the dry valley in the central/southern part of the site. The flintwork for these contexts is overwhelmingly dominated by simple, expediently produced flake-

based material and probably includes a major late prehistoric (Middle Bronze Age or later) component. The smaller, but distinctive, assemblage of flintwork from colluvial sediments and features in Trench 222 includes a high proportion of blade-based material and clearly reflects earlier activity, probably during the earlier Neolithic.

## 4.20 Environmental summary

- 4.20.1 **Charred plant remains and charcoal.** Six bulk samples were taken during the evaluation, primarily for the retrieval and assessment of charred plant remains (CPR) and the recovery of bones and artefacts. Several smaller samples were taken through sediment sequences including colluvium and channel sediments for the recovery of molluscs and for optically stimulated luminescence (OSL) dating, and monoliths were also taken to allow for soil sedimentological analysis. Most of the recovered grain from the bulk samples is either indeterminate or has an uncertain identification, although several samples had charcoal suitable for radiocarbon dating.
- 4.20.2 **Animal bone.** A total of 31 fragments of animal bone, weighting 440g in total was recovered, mainly from features dated to the post-medieval period.
- 4.20.3 **Marine shell.** Eleven valves of European flat oyster were recovered from the post-medieval ditch revealed in Trench 182.
- 4.20.4 **Human remains.** A deposit of cremated bone was recovered from pit 10917. The material represented the remains of a single individual, probably and older juvenile or adult.

## 5 Discussion

---

### 5.1 Reliability of field investigation

- 5.1.1 The layout of trenches provided good overall coverage of the site. However, the need to omit 10 trenches due to crops, trees and low overhead cables left three small areas that were not evaluated in the western and south-eastern areas of the site. The approximate locations of the omitted trenches are shown by their numbers in Fig. 2. Of these areas, the only one that had features revealed in adjacent trenches was the one to the immediate south-east of Trench 123.
- 5.1.2 The archaeological features were sometimes poorly defined against the underlying Boyn Hill Gravels, Thanet Sands and Gravels and hill slope deposits. Initially some deposits were sampled excavated to establish if they were of geological or archaeological significance, and in several cases, putative archaeological features were shown to be no more than variations in natural deposits of sand or gravel.
- 5.1.3 There was a very good correlation between the aerial survey cropmarks and the archaeological features in Trenches 107, 109, 110, 116, 117, 120, 121, 122, 142, 144, 145, 153, 199, 220 and 221. These correlations mainly included linear features, a curvilinear and a large discrete feature, both revealed in Trench 109. Particularly accurate was the correlation between the cropmarks and the recorded features in Trenches 107, 109 and 110, that targeted the rectangular cropmark enclosure in the central part of the site. The results of Trenches 220 and 221, excavated in the north-western corner of the site, also displayed a very good correspondence with the edge of the cropmark complex that extends to the immediate north-west of the site.
- 5.1.4 Some cropmark features, however, including linear ones, did not prove to correspond to features below ground, or only in part. This may indicate that recent ploughing has completely removed features that were still extant in the 20th century.
- 5.1.5 Previously unidentified features were revealed across the site, mainly representing sparse narrow and shallow ditches that had not been detected by the aerial survey. These were revealed in Trenches 7, 8, 17, 20, 35, 36, 63, 64, 77, 87, 98, 106, 109, 115, 118, 123, 171, 182, 185, 200, 205, 214, 216, 225, 233, 237, 238 and 240.

### 5.2 Interpretation

#### Mesolithic/Early Neolithic

- 5.2.1 A small assemblage of early prehistoric flints was found in Trench 222 at the north-west corner of the site. These were recovered from colluvial layers, from ditch 22207 and from an earlier tree-throw truncated by the ditch. The flint from Trench 222 seems to suggest an early Neolithic date and could indicate a small area of early prehistoric activity located in Trench 222. Undiagnostic flint-tempered pottery from this trench was provisionally dated to the later Bronze Age, but could possibly also have been early Neolithic, giving rise to the possibility of a generally homogenous assemblage of material in the colluvium

from this trench. The character of the flint from this trench was relatively fresh, suggesting that there had been little movement of the flints, indicating that the origin of the early Neolithic activity may have been very close by.

- 5.2.2 A ditch or other linear feature containing struck flint of early Neolithic date and pottery that may also be early Neolithic was also found in Trench 240 on the east edge of the site.
- 5.2.3 A few Mesolithic/Neolithic blade-based flints were also retrieved from ditch 8703 in Trench 87. These flints are almost certainly residual in the ditch, but indicate a small area of early prehistoric activity in the vicinity of this trench.
- 5.2.4 Ditch 24005 revealed in Trench 240 in the north-eastern edge of the site was the only feature that could potentially be dated to the early Neolithic period. A small assemblage of 5 sherds of pottery from ditch 24005 stand out from the rest of the prehistoric pottery recovered across the site. The five sherds are flint-tempered, but the fabric is poorly sorted, and the sherds have a smoothed exterior and may date to the early Neolithic. A Neolithic date for ditch 24005 could also be suggested by the fine end scraper found in its single fill, which is of probable Neolithic date. Extensive late Neolithic/Early Bronze Age activity has been recently recorded to the immediate east of Trench 240 (see archaeological background above), but not activity of the early Neolithic. Scattered early Neolithic activity is however known from Mucking 0.8km to the north of the site, and this shows further activity of this nature within the site.

### **Middle Bronze Age to Iron Age**

- 5.2.5 Later Bronze Age or Iron Age activity was widely scattered across the site, with finds occurring in Trenches 20, 64, 77, 109, 123, 128, 225 and 237, and possibly also in Trenches 222 and 240. Pit 12306 in Trench 123 contained pottery of unequivocally middle Bronze Age date, and pit 12308, which cut 12306, pottery of either middle or late Bronze Age date. Part of a hearth base also came from pit 12306, and charred grain, suggesting domestic activity in the vicinity. A vessel buried upright was found *in situ* in a pit in Trench 109, and although not excavated, loose sherds indicate a later Bronze Age date. In Trench 64 parts of two perforated fired clay cylinders of diagnostically late Bronze Age date were found in pit 6404. In Trenches 140 and 141 struck flint of characteristically later prehistoric (later Bronze Age) character was found, including a group that appeared to have been deposited freshly into an erosion gully. Together these indicate a variety of activities carried out on the site in scattered locations in the later Bronze Age, a common pattern of activity in this period of prehistory.
- 5.2.6 The remainder of the pottery of the later prehistoric period was flint-tempered sherds not datable more closely than later Bronze Age or early Iron Age date; the absence of middle Iron Age material was, however, clear. A ditch in Trench 77, a pit or tree-throw hole in Trench 237 and a large pit in Trench 228 contained sufficient sherds to make it probable that they date these features, but only single sherds were recovered from the ditches in Trenches 20 and 225, which may have been residual. In Trenches 222 and 240 the date of the pottery is equivocal; Trench 222 contained small pottery sherds that have been spot-dated as later prehistoric, although as these accompanied struck flint dated to the Neolithic, it is possible that the pottery was also of Neolithic date, while flint-tempered sherds in Trench 240 accompanied by Neolithic

flintwork were dated as early Neolithic, although a middle Bronze Age date is also possible.

- 5.2.7 The presence of a complete ceramic vessel standing upright in a circular pit within the western part of the cropmark sub-rectangular enclosure found in Trenches 107, 109 and 110, and the two cremations (albeit undated) found within a circular or oval enclosure or ring ditch just to the west in Trench 109, could indicate that these enclosures, and the associated cropmark field system, were also of later Bronze Age date. No direct dating evidence was recovered from the sub-rectangular enclosure ditch other than two small sherds, one of late Saxon or late Iron Age/early Roman date, the other a scrap of 5th-7th century organic-tempered pottery, from its upper fill. Similarly, there was no dating evidence from the circular enclosure.
- 5.2.8 The circular enclosure surrounding the cremation burials, which the cropmark suggests was around 15m in diameter and of two phases, certainly suggests a prehistoric rather than a Roman date, and similar examples are known at Mucking (Evans *et al.* 2016). The later Bronze Age pot within a pit may therefore represent peripheral activity, but this does not however demonstrate that the sub-rectangular enclosure was of late Bronze Age date, although it is likely that the pottery arrived in the ditch top long after it had gone out of use. The enclosure could instead have been established adjacent to an existing burial monument at a later date
- 5.2.9 The absence of dating evidence may indicate that the enclosure was not used for domestic occupation, although it must be remembered that only a very small proportion of this was sampled by the evaluation. It is perhaps unlikely that the enclosure is of Roman date, as sites of this period generally generate more pottery than those of later prehistoric date. Despite the evaluation, the associated field system also remains undated.
- 5.2.10 The orientation of the enclosure and nearby ditches reflect the orientation of the dry valley that runs to the west, and the gap between this cropmark system and that further west is explained by the masking of archaeological features below colluvial deposits in the bottom of the valley. The common orientation of this site with that of the Mill House Farm complex just north-west of the site is due to topography, and does not necessarily imply a chronological link between them.

### **Roman**

- 5.2.11 A small assemblage of pottery of late Iron Age and Roman date, consisting of eight body sherds, was recovered from Trenches 7, 123 and 140. Two of the trenches (123 and 140) were in relatively close proximity, but the pottery from them was of respectively early and late Roman date. Despite the prevalence of Roman activity in the surrounding area, this suggests very limited Roman evidence within the site and that activity of this date was restricted to agricultural activity and land division. The paucity of the material indicates that features of this period were probably peripheral to areas of settlement and industry.

### **Early medieval**

- 5.2.12 The only possibly early medieval activity is represented by two small sherds recovered from the top of the sub-rectangular enclosure ditch. One was a

sherd of possibly 10th-11th century date, though this may alternatively have been of late Iron Age-early Roman date. The other was a scrap of 5th-7th century organic-tempered pottery.

### **Medieval**

- 5.2.13 Two features dated to the medieval period were identified within the site. In the south-western part there was an isolated pit (16802) from which 10 sherds of medieval pottery from the same vessel were recovered, while in the eastern part a medieval horseshoe of 12th-14th century type came from pit 21103.

### **Post-medieval**

- 5.2.14 Post-medieval activity was restricted to the southern end of the site in the field adjacent to Low Street. The remains comprised an E-W orientated boundary ditch revealed in Trenches 182 and 185 and two large pits in Trench 183, to the immediate north, that are likely to represent evidence for gravel extraction in the area. The boundary ditch, which is not depicted in historic mapping, produced 16 sherds of pottery dated to the mid-16th century, copper alloy sheet with a paperclip rivet of 16th century date and a mixture of CBM of 16th and 18th century date including part of a Georgian chimney pot. One of the quarry pits revealed in Trench 183, which had much stone in the fill, contained 11 sherds of post-medieval pottery of similar 16th century date and a similar mix of CBM of 16th – 18th century date. Although the pit in Trench 175 was undated, it is likely that this was part of the same activity recorded in the adjacent trenches to the south.
- 5.2.15 The activity is interpreted as the use of the area for quarrying, and the subsequent dumping of occupation and building debris when backfilling the quarries, which also overflowed into the adjacent ditch. These remains are very likely to be related to a late medieval or early post-medieval building in the adjacent hamlet of Low Street. No structural remains were identified during the evaluation, so it is clear that the settlement did not extend as far north as this, although due to the constraints on the trench layout it is not possible to exclude the former existence of plots immediately east of Low Street Lane.

### **Features of geological and natural origin**

- 5.2.16 The site contained a number of natural features, as well as three-throw holes.
- 5.2.17 In earlier prehistory tree-throw holes were sometimes used as shelters during hunting trips, or as repositories for large quantities of finds, and in later periods sometimes contain significant groups of finds, enabling a history of deforestation to be charted. On this site, a small three-throw hole in Trench 222 produced struck flints of Neolithic character and pottery of either Neolithic or later Bronze Age date, and a tree-throw hole or small pit in Trench 237 contained a small quantity of later Bronze Age or early Iron Age pottery.

## **5.3 Evaluation objectives and results**

### **General Aims**

- 5.3.1 **Aims i-iii.** The evaluation established the presence of archaeological remains of Neolithic, middle Bronze Age to Iron Age, Roman, medieval and post-medieval date and investigated their character by analysing their relationship to cropmark evidence, artefacts and environmental evidence. The evaluation also tested the cropmark evidence as identified by the 2019 aerial survey

(Place Services 2019) and investigated the apparently blank areas where no cropmarks had been identified. Trenching of the blank areas did also reveal some limited activity at the north and south ends of land parcel 9 that was not indicated by cropmark evidence.

- 5.3.2 **Aim iv.** The evaluation has revealed that the archaeological remains are generally not very dense or stratified, but has identified areas of colluvium, principally in the centre of the site, where vertical stratigraphy is present, and within which remains of more than one period are represented. The deeper trenches have established that there are deep deposit sequences containing archaeological features, but no intact buried archaeological horizons have been identified for certain.
- 5.3.3 **Aims v-vi.** The evaluation has established the date of the remains present, the state and preservation of the archaeological artefacts and has provided indications of activities carried out within the evaluated sample of the site, but except perhaps for the later Bronze Age, information about the economy and status of the past inhabitants of the site is limited. This is due to the relative paucity of archaeology across the site.
- 5.3.4 **Aim vii.** Paleoenvironmental samples were recovered and have demonstrated the state of preservation and potential for environmental information. This appears in general to be limited, although post-medieval animal bones and oyster shells are relatively well-preserved.
- 5.3.5 **Aim viii.** The excavation of both deep and shallow trenches supplemented by the recovery of samples for specialist dating have provided evidence about the chronology and character of the sedimentary sequences in the dry valley.

#### **Site Specific Objectives**

- 5.3.6 **Aims xiii.** The evaluation was conducted within the parameters and objectives of the revised East of England Research Framework (Medlycott 2011) and takes account of the aims and objectives of the Greater Thames Estuary Historic Environment Research Framework.
- 5.3.7 **Aim xiv.** Overall, the cropmarks proved to be a reasonable indicator of the principal areas of activity, particularly around Trenches 220 and 109. Although as is often the case with cropmarks, they were not always a precise indicator for the density of features or the presence of smaller discrete features. Where the depth of overburden was above average features were not indicated, and the activity at the north and south of land parcel 9 was not represented by cropmarks either.
- 5.3.8 **Aim xv.** No Upper Palaeolithic or Mesolithic finds were certainly identified during the evaluation, although a small number of later Mesolithic or early Neolithic flints were found. However, the topographical and geological conditions observed are conducive to the survival of artefacts of these periods at greater depth.
- 5.3.9 **Aim xvi-xvii.** Excavation of the dry valley did reveal deeper sequences of colluvium and highlight the existence of probable Pleistocene deposits., although no artefacts of Pleistocene date were found. One potentially *in situ* deposit of later prehistoric struck flint was found within an erosion gully in Trench 141, and the struck flint from the colluvium in Trench 222 was fairly fresh, implying little movement of the material, but otherwise the finds were

generally abraded and redeposited in colluvial deposits, rather than on preserved buried land surfaces.

- 5.3.10 **Aims xvii-xx.** The only funerary evidence was encountered in Trench 109 where at least two cremation pits were recorded. Although the date of the excavated example has not been established it appears to be located within an annular or penannular enclosure, defined by ditch 10913 and corresponding cropmarks. It is possible that these represent the remains of a Bronze Age burial mound or, if the burials were later Bronze Age, a flat cemetery. No early Bronze Age features or finds were discovered in the vicinity, but a later Bronze Age vessel was found upright within a pit only 30m to the east, and this probable storage vessel suggests that there was habitation in the vicinity. The vessel lay within a rectilinear enclosure, but this was poorly dated, the only finds coming from the top of the ditch, and comprising a small scrap of 5th-7th century organic-tempered pottery and a sherd of either late Saxon or late Iron Age/Roman pottery, so this is not necessarily associated with the burials.
- 5.3.11 **Aim xxi.** The evaluation has shown that the cropmark enclosure system at Mill House Farm north-west of the site did not extend much further into the site than indicated by the cropmarks. Unfortunately, no dating evidence was recovered from any of the associated ditches to help date this activity. As mentioned above, the sub-rectangular enclosure was not well-dated, so its relationship to the activity at Mill House Farm remains unclear.
- 5.3.12 **Aim xxii-xxiv.** Only a small assemblage of Roman pottery was recovered from across the evaluation area. This was recovered from ditches, but these did not form part of clear field systems. The evidence points to very limited activity during the late Iron Age and early Roman and late Roman periods, probably of an entirely agricultural nature.
- 5.3.13 **Aim xxvi-xxviii.** The evaluation has produced dating evidence for some of the post-medieval field boundaries on the site. No buried remains of medieval droeways were encountered. Although it was not possible to confidently determine the presence or absence of medieval or post-medieval farmsteads along the southern end of Low Street Lane, quarry pits at the very south end of the site indicate activity related to late medieval and early post-medieval buildings close by, and a ditch may be related to former plots in this area.



## Appendix A Trench Tables

Trench 1								
General description						Orientation		E-W
Trench devoid of archaeology. Trench consists of ploughsoil overlaying a natural silty sandy gravel						Length (m)		30
						Width (m)		2.1
						Avg. depth (m)		0.33
Context No.	Type	Fill Of	Width (m)	Depth (m)	Description	Finds	Date	
100	Layer		2.1	0.3	Ploughsoil. Mid grey brown, silty sand, friable with rooting and rounded stone inclusions			
101	Layer		2.1		Natural. Light greyish brown, silty sand			
102	Cut				Natural Feature. light greyish brown silty sand			
Trench 2								
General description						Orientation		NW-SE
Trench devoid of archaeology. Consists of ploughsoil overlaying a natural of silty gravel						Length (m)		30
						Width (m)		2.1
						Avg. depth (m)		0.32
Context No.	Type	Fill Of	Width (m)	Depth (m)	Description	Finds	Date	
200	Layer		2.1	0.32	Ploughsoil. Mid grey brown, silty sand with rounded pebble inclusions. Friable			
201	Layer		2.1		Natural. Mid reddish orange silty gravel, firm			
Trench 3								
General description						Orientation		N-S
Trench devoid of archaeology. Consists of ploughsoil overlaying natural geology of sandy clay gravels.						Length (m)		30
						Width (m)		2.1
						Avg. depth (m)		0.3
Context No.	Type	Fill Of	Width (m)	Depth (m)	Description	Finds	Date	
300	Layer			0.3	Ploughsoil. Mid greyish brown, silty sand			
301	Layer				Natural. Mid reddish orange, silty sand and gravel.			
Trench 4								
General description						Orientation		E-W
Trench devoid of archaeology. Consists of ploughsoil and subsoil overlaying natural gravels.						Length (m)		30
						Width (m)		2.1
						Avg. depth (m)		0.5
Context No.	Type	Fill Of	Width (m)	Depth (m)	Description	Finds	Date	
400	Layer			0.3	Ploughsoil. Dark grey brown sandy silt.			
401	Layer			0.2	Subsoil. Mid orangey brown silty sand.			

402	Layer				Natural. Reddish brown and light brown sandy gravels.		
Trench 5							
General description					Orientation		E-W
Trench devoid of archaeology. Consists of ploughsoil and subsoil overlying natural gravels.					Length (m)		30
					Width (m)		2.1
					Avg. depth (m)		0.5
Context No.	Type	Fill Of	Width (m)	Depth (m)	Description	Finds	Date
500	Layer			0.3	Ploughsoil. Dark grey brown sandy silt.		
501	Layer			0.2	Subsoil. Mid orangey brown, sandy silt.		
502	Layer				Natural. Reddish brown and light brown sandy gravels.		
Trench 6							
General description					Orientation		E-W
Trench devoid of archaeology. Consists of ploughsoil and subsoil overlying silty clay natural.					Length (m)		30
					Width (m)		2.1
					Avg. depth (m)		0.4
Context No.	Type	Fill Of	Width (m)	Depth (m)	Description	Finds	Date
600	Layer		2.1	0.2	Ploughsoil. Mid grey brown silty sand, with rooting and rounded pebble inclusions		
601	Layer		2.1	0.2	Subsoil. Mid orangey brown silty sand, friable		
602	Layer		2.1		Natural. Mid reddish brown with light yellowish patches, silty clay with solid silt patches, firm		
Trench 7							
General description					Orientation		E-W
Trench revealed one ditch. Consists of ploughsoil and subsoil overlying natural geology of gravel.					Length (m)		30
					Width (m)		2.1
					Avg. depth (m)		0.4
Context No.	Type	Fill Of	Width (m)	Depth (m)	Description	Finds	Date
700	Layer		2.2	0.43	Ploughsoil. Firm Dark greyish brown silty clay		
701	Layer		2.2	0.2	Subsoil. Mid. Soft, Mid orange brown silty clay		
702	Layer		2.2		Natural. Compact/firm Light yellowish brown sandy clay gravel		
703	Cut		1	0.32	Ditch		
704	Fill	703	1	0.32	Primary Fill. Orangey brown, silty clay	Pot	AD 250-410
Trench 8							
General description					Orientation		E-W
Trench revealed one ditch. Consisted of ploughsoil and subsoil overlying natural.					Length (m)		30
					Width (m)		2.1

						Avg. depth (m)	0.55
Context No.	Type	Fill Of	Width (m)	Depth (m)	Description	Finds	Date
800	Layer		2.1	0.2	Ploughsoil. Mid grey brown		
801	Layer		2.1	0.35	Subsoil. Mid orangey brown		
802	Layer		2.1		Natural. Mid yellowish brown		
803	Cut		0.5	0.16	Ditch		
804	Fill	803	0.5	0.16	Secondary Fill. Light yellowish brown		

Trench 9

General description						Orientation	NE-SW
Trench devoid of archaeology. Ploughsoil overlying natural geology of gravel and sands.						Length (m)	30
						Width (m)	2.1
						Avg. depth (m)	0.54

Context No.	Type	Fill Of	Width (m)	Depth (m)	Description	Finds	Date
900	Layer		2.1	0.35	Ploughsoil. Mid grey brown silty sand, with rooting and pebble inclusions		
901	Layer		2.1	0.14	Subsoil. Mid brownish orange silty clay, firm		
902	Layer		2.1		Natural. Mid reddish brown silty clay with yellowish silty patches, firm		

Trench 10

General description						Orientation	E-W
Trench devoid of archaeology. Consists of ploughsoil and subsoil overlaying a silty clay, gravel natural.						Length (m)	30
						Width (m)	2.1
						Avg. depth (m)	0.39

Context No.	Type	Fill Of	Width (m)	Depth (m)	Description	Finds	Date
1000	Layer		2.1	0.3	Ploughsoil. Mid greyish brown silty sand, friable with rooting and pebble inclusions		
1001	Layer		2.1	0.09	Subsoil. Mid orangey brown, silty clay, friable with occasional rounded stone inclusions		
1002	Layer		2.1		Natural. Mid yellowish brown silty sand with patches of clay and gravel, firm		

Trench 11

General description						Orientation	N-S
Trench devoid of archaeology. Consists of ploughsoil and subsoil overlaying silty natural						Length (m)	30
						Width (m)	2.1
						Avg. depth (m)	0.5

Context No.	Type	Fill Of	Width (m)	Depth (m)	Description	Finds	Date
1100	Layer		2.1	0.3	Ploughsoil. Mid grey brown silty sand, with rooting and rounded stone inclusions, friable		
1101	Layer		2.1	0.25	Subsoil. Mid orangey brown silty sand, friable		

1102	Layer		2.1		Natural. Mid reddish brown with yellow patches. Silty sand with gravel patches, friable		
Trench 12							
General description					Orientation		NW-SE
Trench devoid of archaeology. Consists of ploughsoil and subsoil overlaying a natural of silty gravel					Length (m)		30
					Width (m)		2.1
					Avg. depth (m)		0.5
Context No.	Type	Fill Of	Width (m)	Depth (m)	Description	Finds	Date
1200	Layer		2.1	0.2	Ploughsoil. Mid greyish brown silty sand, friable with rooting and rounded stone inclusions		
1201	Layer		2.1	0.2	Subsoil. Mid orangey brown, silty sand, friable		
1202	Layer		2.1		Natural. Mid reddish yellowy brown, silt, with large patches of gravel. Firm		
Trench 13							
General description					Orientation		N-S
Trench devoid of archaeology. Consists of ploughsoil and subsoil overlaying natural					Length (m)		30
					Width (m)		2.1
					Avg. depth (m)		0.5
Context No.	Type	Fill Of	Width (m)	Depth (m)	Description	Finds	Date
1300	Layer		2.1	0.3	Ploughsoil. Mid grey brown silty sand with rooting and rounded stone inclusions		
1301	Layer		2.1	0.17	Subsoil. Mid brownish orange, silty sand, friable with occasional flint inclusions		
1302	Layer		2.1		Natural. Mid reddish brown with light yellowish patches, silty gravel, firm		
Trench 14							
General description					Orientation		N-S
Trench devoid of archaeology. Consists of ploughsoil and subsoil overlaying a silty clay gravel natural.					Length (m)		30
					Width (m)		2.1
					Avg. depth (m)		0.5
Context No.	Type	Fill Of	Width (m)	Depth (m)	Description	Finds	Date
1400	Layer		2.1	0.3	Ploughsoil. Mid greyish brown silty sand, friable with rounded stone and rooting inclusions		
1401	Layer		2.1	0.2	Subsoil. Mid orangey brown, silty sand, friable		
1402	Layer		2.1		Natural. Mid reddish brown silty clay with gravel patches		
Trench 15							
General description					Orientation		NW-SE
Trench devoid of archaeology. Consists of ploughsoil and subsoil overlying natural geology of silty sand with patches of gravel.					Length (m)		30
					Width (m)		2.3

						Avg. depth (m)	0.55
Context No.	Type	Fill Of	Width (m)	Depth (m)	Description	Finds	Date
1500	Layer			0.3	Ploughsoil. Loose light grey brown sandy silt.		
1501	Layer			0.2	Subsoil. Light yellowish brown sandy silt.		
1502	Layer				Natural. Mid orangish brown silty sand with patches of gravel.		
Trench 16							
General description						Orientation	NW-SE
Trench devoid of archaeology. Consists of ploughsoil and subsoil overlying natural geology of gravel.						Length (m)	30
						Width (m)	2.3
						Avg. depth (m)	0.5
Context No.	Type	Fill Of	Width (m)	Depth (m)	Description	Finds	Date
1600	Layer			0.3	Ploughsoil. Loose mid brownish grey sandy silt		
1601	Layer			0.2	Subsoil. Mid greyish brown sandy silt.		
1602	Layer				Natural. Gravel with patches of orangish brown silty sand.		
Trench 17							
General description						Orientation	E-W
Two ditches revealed. Consists of ploughsoil and subsoil overlying natural gravel.						Length (m)	30
						Width (m)	2.1
						Avg. depth (m)	0.66
Context No.	Type	Fill Of	Width (m)	Depth (m)	Description	Finds	Date
1700	Layer		2.1	0.4	Ploughsoil. Mid grey brown, silty sand, friable, with rooting and rounded stone inclusions		
1701	Layer		2.1	0.26	Subsoil. Mid orangish brown, silty sand, friable		
1702	Layer		2.1		Natural. Mid orangey reddish brown silty clay with gravel patches, firm		
1703	Cut		0.95	0.42	Ditch. NW/SE orientated, with steep sides and concave base.		
1704	Fill		0.95	0.42	Secondary Fill. Mottled light brown grey sandy silt.	Burnt Flint	
1705	Unexcavated feature		0.65		Ditch. NW/SE orientated, containing a light grey sandy silt fill.		
Trench 18							
General description						Orientation	N-S
Trench devoid of archaeology. Consists of ploughsoil and subsoil overlying natural						Length (m)	30
						Width (m)	2.1
						Avg. depth (m)	0.55
Context No.	Type	Fill Of	Width (m)	Depth (m)	Description	Finds	Date

1800	Layer		2.1	0.3	Ploughsoil. Mid grey brown silty sand, friable with rooting and rounded stone inclusions		
1801	Layer		2.1	0.25	Subsoil. Mid orangey brown, silty sand, friable		
1802	Layer		2.1		Natural. Mid reddish brown, silty clay, firm		
Trench 19							
General description					Orientation		E-W
Trench devoid of archaeology. Consists of ploughsoil and subsoil overlaying gravel natural.					Length (m)		30
					Width (m)		2.1
					Avg. depth (m)		0.68
Context No.	Type	Fill Of	Width (m)	Depth (m)	Description	Finds	Date
1900	Layer		2.1	0.38	Ploughsoil. Mid grey brown, silty sand, friable with rooting and rounded stone inclusions		
1901	Layer		2.1	0.23	Subsoil. Mis orangey brown silty clay, friable		
1902	Layer		2.1		Natural. Mid reddish orange silty clay with gravel patches throughout		
Trench 20							
General description					Orientation		NW-SE
Trench revealed one ditch. Consists of ploughsoil and subsoil overlaying natural geology of gravel with patches of brown sandy silt.					Length (m)		30
					Width (m)		2.1
					Avg. depth (m)		0.5
Context No.	Type	Fill Of	Width (m)	Depth (m)	Description	Finds	Date
2000	Layer		2.1	0.34	Ploughsoil. Mid grey brown silty sand, friable, with rooting and rounded stone inclusions		
2001	Layer		2.1	0.17	Subsoil. Mid orangey brown. Silty sand, friable		
2002	Layer		2.1		Natural. Mid reddish orange, silty sand with gravel patches throughout		
2003	Cut		0.7	0.22	Ditch. NE/SW aligned ditch identified in the central part of Trench 20.		
2004	Fill		0.7	0.22	Secondary Fill. Single sedimentary fill of ditch 2003. A small amount of pottery has been retrieved from this context.	Pot	MBA-IA
Trench 21							
General description					Orientation		E-W
Trench devoid of archaeology. Consists of ploughsoil and subsoil overlaying natural					Length (m)		30
					Width (m)		2.1
					Avg. depth (m)		0.6
Context No.	Type	Fill Of	Width (m)	Depth (m)	Description	Finds	Date
2100	Layer		2.1	0.4	Ploughsoil. Mid grey brown. Silty sand, friable with rooting and rounded stone inclusions		
2101	Layer		2.1	0.2	Subsoil. Mid grey brown, silty sand, friable		

2102	Layer		2.1		Natural. Mid reddish brown silty clay with gravel patches throughout		
Trench 22							
General description					Orientation		NW-SE
Trench devoid of archaeology. Consists of ploughsoil and subsoil overlaying natural geology of gravel with patches of brown sandy silt.					Length (m)		30
					Width (m)		2.2
					Avg. depth (m)		0.8
Context No.	Type	Fill Of	Width (m)	Depth (m)	Description	Finds	Date
2200	Layer			0.35	Ploughsoil. Mid brownish grey sandy silt.		
2201	Layer			0.25	Subsoil. Light yellowish brown sandy silt.		
2202	Layer				Natural. Gravel with frequent patches of brown sandy silt.		
Trench 23							
General description					Orientation		NW-SE
Trench devoid of archaeology. Consists of ploughsoil and subsoil overlying natural geology of gravel.					Length (m)		30
					Width (m)		2.3
					Avg. depth (m)		0.7
Context No.	Type	Fill Of	Width (m)	Depth (m)	Description	Finds	Date
2300	Layer			0.4	Ploughsoil. Mid brownish grey sandy silt.		
2301	Layer			0.35	Subsoil. Light greyish brown sandy silt.		
2302	Layer				Natural. Light brown clay sandy gravels.		
Trench 24							
General description					Orientation		NW-SE
Trench devoid of archaeology. Consists of ploughsoil and subsoil overlying natural geology of gravel.					Length (m)		30
					Width (m)		2.3
					Avg. depth (m)		0.55
Context No.	Type	Fill Of	Width (m)	Depth (m)	Description	Finds	Date
2400	Layer			0.35	Ploughsoil. Dark greyish brown sandy silt.		
2401	Layer			0.2	Subsoil. Light greyish brown sandy silt.		
2402	Layer				Natural. Silty clay gravels		
Trench 25							
General description					Orientation		NW-SE
Trench devoid of archaeology. Consists of ploughsoil and subsoil overlying natural geology of gravel.					Length (m)		30
					Width (m)		2.3
					Avg. depth (m)		0.6
Context No.	Type	Fill Of	Width (m)	Depth (m)	Description	Finds	Date
2500	Layer			0.35	Ploughsoil. Loose mid brownish grey sandy silt.		
2501	Layer			0.25	Subsoil. Light brown sandy silt.		

2502	Layer				Natural. Gravel with patches of light brown sandy silt.		
Trench 26							
General description					Orientation		NW-SE
Trench devoid of archaeology. Consists of ploughsoil, subsoil and natural geology of gravels.					Length (m)		30
					Width (m)		2.3
					Avg. depth (m)		0.55
Context No.	Type	Fill Of	Width (m)	Depth (m)	Description	Finds	Date
2600	Layer			0.35	Ploughsoil. Grey brown sandy silt.		
2601	Layer			0.2	Subsoil. Light brown sandy silt.		
2602	Layer				Natural. light brown sand and gravel		
Trench 27							
General description					Orientation		E-W
Trench devoid of archaeology. Consists of ploughsoil overlying natural geology of gravel.					Length (m)		30
					Width (m)		2.1
					Avg. depth (m)		0.3
Context No.	Type	Fill Of	Width (m)	Depth (m)	Description	Finds	Date
2700	Layer		2.1	0.3	Ploughsoil. Mid brown silt with 5% <40mm rounded flint		
2701	Layer				Natural. Flint gravel in a light brown silty clay matrix		
Trench 28							
General description					Orientation		N-S
Trench devoid of archaeology. Consists of ploughsoil overlying natural geology of sandy silt.					Length (m)		30
					Width (m)		2.1
					Avg. depth (m)		0.68
Context No.	Type	Fill Of	Width (m)	Depth (m)	Description	Finds	Date
2800	Layer		2.1	0.33	Ploughsoil. Dark brownish grey, sandy silt, firm		
2801	Layer		2.1		Natural. Mid reddish brown, sandy gravel, loose		
2802	Layer		2.1	0.5	Natural. Light reddish brown, clayey silt, soft (possible Pleistocene colluvium)		
Trench 29							
General description					Orientation		E-W
Trench devoid of archaeology. Consists of ploughsoil overlying natural geology of silty sand.					Length (m)		30
					Width (m)		2.1
					Avg. depth (m)		0.37
Context No.	Type	Fill Of	Width (m)	Depth (m)	Description	Finds	Date
2900	Layer			0.37	Ploughsoil. Mid brownish grey friable sandy silt		



2901	Layer				Natural. Sub rounded flint gravel in a mid orangey brown silty sand matrix		
Trench 30							
General description					Orientation		NE-SW
Trench devoid of archaeology. Consists of ploughsoil overlying natural geology of gravelly clayey sand.					Length (m)		30
					Width (m)		2.1
					Avg. depth (m)		0.38
Context No.	Type	Fill Of	Width (m)	Depth (m)	Description	Finds	Date
3000	Layer			0.38	Ploughsoil. Mid brownish grey friable sandy silt		
3001	Layer				Natural. reddish brown, gravelly sand		
Trench 31							
General description					Orientation		N-S
Trench devoid of archaeology. Consists of ploughsoil overlying natural geology of gravelly clayey sand.					Length (m)		30
					Width (m)		2.1
					Avg. depth (m)		0.36
Context No.	Type	Fill Of	Width (m)	Depth (m)	Description	Finds	Date
3100	Layer			0.36	Ploughsoil. Mid brownish grey friable sandy silt		
3101	Layer				Natural. reddish brown, clayey gravelly sand		
Trench 32							
General description					Orientation		E-W
Trench devoid of archaeology. Consists of ploughsoil overlying natural geology of gravelly sand.					Length (m)		30
					Width (m)		2.1
					Avg. depth (m)		0.38
Context No.	Type	Fill Of	Width (m)	Depth (m)	Description	Finds	Date
3200	Layer			0.38	Ploughsoil. Mid brownish grey friable sandy silt		
3201	Layer				Natural. reddish brown, gravelly sand		
Trench 33							
General description					Orientation		NW-SE
Trench devoid of archaeology. Consists of ploughsoil overlying natural geology of gravelly sand.					Length (m)		30
					Width (m)		2.1
					Avg. depth (m)		0.38
Context No.	Type	Fill Of	Width (m)	Depth (m)	Description	Finds	Date
3300	Layer			0.38	Ploughsoil. Mid brownish grey friable sandy silt		
3301	Layer				Natural. Sub rounded flint gravel in a mid orangey brown silty sand matrix		
Trench 34							

General description						Orientation		NW-SE	
Trench devoid of archaeology. Consists of ploughsoil overlying natural geology of sandy gravel.						Length (m)		30	
						Width (m)		2.1	
						Avg. depth (m)		0.24	
Context No.	Type	Fill Of	Width (m)	Depth (m)	Description	Finds	Date		
3400	Layer		2.1	0.24	Ploughsoil. Dark brownish grey, sandy silt, friable				
3401	Layer		2.1		Natural. Light reddish brown, sandy gravel, loose				
Trench 35									
General description						Orientation		N-S	
Trench revealed a single ditch at the southern end. Consists of ploughsoil and subsoil overlying natural geology of clayey silt.						Length (m)		30	
						Width (m)		2.1	
						Avg. depth (m)		0.57	
Context No.	Type	Fill Of	Width (m)	Depth (m)	Description	Finds	Date		
3500	Layer		2.1	0.4	Ploughsoil. Dark brownish grey, sandy silt, friable				
3501	Layer			0.17	Subsoil. Light brown, sandy silt				
3502	Layer		2.1		Natural. Brickearth, mid reddish brown, clayey silt.				
3503	Cut		1.1	0.44	Ditch. linear, central part of the trench, same as 3603				
3504	Fill	3503	1.1	0.44	Secondary Fill. dark greyish brown clayey silt	Struck Flint			
Trench 36									
General description						Orientation		NNW-SSE	
Trench revealed a single ditch at the southern end. Consists of ploughsoil and subsoil overlying natural geology of silty sand and sandy chalk.						Length (m)		30	
						Width (m)		2.1	
						Avg. depth (m)		0.5	
Context No.	Type	Fill Of	Width (m)	Depth (m)	Description	Finds	Date		
3600	Layer		2.1	0.3	Ploughsoil. Dark brownish grey, sandy silt, friable				
3601	Layer		2.1	0.5	Natural. Light brownish red, sandy silt, soft				
3602	Layer		2.1		Natural. Light brownish grey, sandy chalk, firm				
3603	Cut		0.7	0.12	Ditch. linear, shallow, central-southern part of the trench, visible only in the baulk section				
3604	Layer			0.2	Subsoil. Light brown clayey silt				
3605	Fill	3603	0.7	0.12	Secondary Fill. firm dark greyish brown clayey silt	Fe			
Trench 37									
General description						Orientation		N-S	
Trench devoid of archaeology. Consists of ploughsoil and subsoil overlying natural geology of gravelly sand.						Length (m)		30	
						Width (m)		2.1	

						Avg. depth (m)	0.58
Context No.	Type	Fill Of	Width (m)	Depth (m)	Description	Finds	Date
3700	Layer			0.36	Ploughsoil. Mid brownish grey friable sandy silt		
3701	Layer			0.22	Subsoil. Light orangey brown clayey fine sand only in southern half of trench		
3702	Layer				Natural. red brownish, gravelly sand, flints		
Trench 38							
General description						Orientation	E-W
Trench devoid of archaeology. Consists of ploughsoil overlying natural geology of gravel.						Length (m)	30
						Width (m)	2.1
						Avg. depth (m)	0.5
Context No.	Type	Fill Of	Width (m)	Depth (m)	Description	Finds	Date
3800	Layer			0.35	Ploughsoil. Mid brownish grey silt with 10% <100mm sub rounded flint		
3801	Layer				Natural. Sub rounded flint gravel in a matrix of light orangey brown and yellowish brown sand		
Trench 39							
General description						Orientation	N-S
Trench devoid of archaeology. Consists of ploughsoil and subsoil overlying natural geology of clayey silt.						Length (m)	30
						Width (m)	2.1
						Avg. depth (m)	0.5
Context No.	Type	Fill Of	Width (m)	Depth (m)	Description	Finds	Date
3900	Layer			0.4	Ploughsoil. Mid brownish grey silt with 5% <100mm rounded flint		
3901	Layer			0.35	Natural. Mid reddish brown clayey silt, possible Pleistocene colluvium		
3902	Layer				Natural. Light grey and white degraded chalk		
3903	Layer			0.2	Subsoil. Light reddish brown clayey silt		
3904	Layer				Natural. Gravel head deposit for the northern 11m of the trench constituting sub rounded flint gravel in a mid reddish brown silty sand matrix		
Trench 40							
General description						Orientation	E-W
Trench devoid of archaeology. Consists of ploughsoil and subsoil overlying natural geology of silty sand.						Length (m)	30
						Width (m)	2.1
						Avg. depth (m)	0.56
Context No.	Type	Fill Of	Width (m)	Depth (m)	Description	Finds	Date
4000	Layer			0.38	Ploughsoil. Mid brownish grey friable sandy silt		
4001	Layer			0.44	Natural. Light orangey brown, clayey sand, firm. Possible Pleistocene colluvium		

4002	Layer				Natural. white orangish, chalky sand		
4003	Layer			0.18	Subsoil. Light yellowish brown clayey silt (overlying 4001)		
Trench 41							
General description					Orientation		NE-SW
Trench devoid of archaeology. Consists of ploughsoil and subsoil overlying natural geology of clayey silt.					Length (m)		30
					Width (m)		2.1
					Avg. depth (m)		0.6
Context No.	Type	Fill Of	Width (m)	Depth (m)	Description	Finds	Date
4100	Layer		2.1	0.4	Ploughsoil. Dark brownish grey, sandy silt, soft		
4101	Layer		2.1	0.4	Natural. Light brownish red, clayey silt, firm. Brickearth. Possible Pleistocene colluvium. Below subsoil.		
4102	Layer		2.1		Natural. Light grey, calcareous clayey silt, soft		
4103	Layer				Natural. Light brownish red silty clay (interspersed with calcareous clay 4102)		
4104	Layer			0.2	Subsoil. Light brown silty clay		
Trench 42							
General description					Orientation		NE-SW
Trench devoid of archaeology. Consists of ploughsoil and subsoil overlying natural geology of brickearth.					Length (m)		30
					Width (m)		2.1
					Avg. depth (m)		0.51
Context No.	Type	Fill Of	Width (m)	Depth (m)	Description	Finds	Date
4200	Layer		2.1	0.3	Ploughsoil. Dark brownish grey, sandy silt, friable		
4201	Layer		2.1	0.21	Subsoil. Light brown clayey silt		
4202	Layer		2.1		Natural. Brickearth, mid brownish red, sandy silt, soft (possible Pleistocene colluvium)		
Trench 43							
General description					Orientation		E-W
Trench devoid of archaeology. Consists of ploughsoil and subsoil overlying natural geology of sandy silt with chalk inclusions.					Length (m)		30
					Width (m)		2.1
					Avg. depth (m)		0.5
Context No.	Type	Fill Of	Width (m)	Depth (m)	Description	Finds	Date
4300	Layer		2.1	0.4	Ploughsoil. Dark brownish grey, sandy silt, friable		
4301	Layer		2.1	0.5	Natural. Light reddish brown, sandy silt, soft (possible Pleistocene colluvium)		
4302	Layer		2.1		Natural. Light brownish grey, sandy silt with chalk inclusions, soft		
4303	Layer			0.1	Subsoil. Light reddish brown clayey silt, laying above 4301		

Trench 44								
General description						Orientation		N-S
Trench devoid of archaeology. Consists of ploughsoil and subsoil overlying natural geology of chalky sand and mid orangey brown clayey sand.						Length (m)		30
						Width (m)		2.1
						Avg. depth (m)		0.56
Context No.	Type	Fill Of	Width (m)	Depth (m)	Description	Finds	Date	
4400	Layer			0.38	Ploughsoil. Mid brownish grey friable sandy silt			
4401	Layer			0.45	Natural. Light orangey brown clayey sand, firm. Possible Pleistocene colluvium			
4402	Layer				Natural. white orangish, chalky sand			
4403	Layer			0.15	Subsoil. Mid yellowish brown clayey silt			
Trench 45								
General description						Orientation		E-W
Trench devoid of archaeology. Consists of ploughsoil and subsoil overlying natural geology of reddish brown clayey silt and chalky sand.						Length (m)		30
						Width (m)		2.1
						Avg. depth (m)		0.45
Context No.	Type	Fill Of	Width (m)	Depth (m)	Description	Finds	Date	
4500	Layer			0.38	Ploughsoil. Mid brownish grey friable sandy silt			
4501	Layer			0.47	Natural. Light brown orangish/greyish, clayey sand, firm. Possible Pleistocene colluvium.			
4502	Layer				Natural. white orangish, chalky sand			
4503	Layer			0.15	Subsoil. Light reddish brown clayey silt			
Trench 46								
General description						Orientation		N-S
Trench devoid of archaeology. Consists of ploughsoil and subsoil overlying natural geology of sandy clay.						Length (m)		30
						Width (m)		2.1
						Avg. depth (m)		0.58
Context No.	Type	Fill Of	Width (m)	Depth (m)	Description	Finds	Date	
4600	Layer			0.38	Ploughsoil. Mid brownish grey friable sandy silt			
4601	Layer			0.2	Subsoil. Light orangey brown, clayey sand, firm.			
4602	Layer				Natural. red brownish, sandy clay - possible Pleistocene colluvium			
4603	Void							
Trench 47								
General description						Orientation		NNW-SSE
Trench devoid of archaeology. Consists of ploughsoil overlying a natural geology of sandy gravel.						Length (m)		30
						Width (m)		2.1
						Avg. depth (m)		0.59

Context No.	Type	Fill Of	Width (m)	Depth (m)	Description	Finds	Date
4700	Layer		2.1	0.34	Ploughsoil. Dark brownish grey, sandy silt, friable		
4701	Layer		2.1		Natural. Light brownish red, sandy gravel, loose		
4702	Layer		2.1	0.41	Natural. Light reddish brown, clayey silt, soft. Brickearth. Possible Pleistocene colluvium.		
4703	Layer			0.25	Subsoil. Light reddish brown clayey silt		

#### Trench 48

General description	Orientation	N-S
Trench devoid of archaeology. Consists of ploughsoil and subsoil overlying a natural geology of silty sand and gravel.	Length (m)	30
	Width (m)	2.1
	Avg. depth (m)	0.41

Context No.	Type	Fill Of	Width (m)	Depth (m)	Description	Finds	Date
4800	Layer		2.1	0.24	Ploughsoil. Mid brownish grey, sandy silt, friable.		
4801	Layer		2.1	0.46	Natural. Mid reddish brown, sandy silt, soft (possible Pleistocene colluvium)		
4802	Layer		2.1		Natural. Light brownish red, sandy gravel, loose		
4803	Layer			0.17	Subsoil. Light reddish brown clayey silt		

#### Trench 49

General description	Orientation	E-W
Trench revealed a pit at the western end. Consists of ploughsoil and subsoil overlying natural geology of sandy gravel.	Length (m)	30
	Width (m)	2.1
	Avg. depth (m)	0.7

Context No.	Type	Fill Of	Width (m)	Depth (m)	Description	Finds	Date
4900	Layer		2.1	0.2	Ploughsoil. Mid brownish grey, sandy silt, soft		
4901	Layer		2.1	0.5	Colluvial Layer. Light reddish brown, sandy silt, soft		
4902	Layer		2.1		Natural. Light brownish red, sandy gravel, loose		
4903	Cut		0.76	0.22	Pit		
4904	Fill	4903	0.76	0.22	Primary Fill. Moderately compact, light orange brown, silty sand		

#### Trench 50

General description	Orientation	NW-SE
Trench devoid of archaeology. Consists of ploughsoil overlying natural geology of gravel.	Length (m)	30
	Width (m)	2.1
	Avg. depth (m)	0.5

Context No.	Type	Fill Of	Width (m)	Depth (m)	Description	Finds	Date
5000	Layer			0.3	Ploughsoil. Mid brownish grey silt with 10% <100mm sub rounded flint		

5001	Layer				Natural. Sub rounded flint gravel in light orangey brown silty sand matrix		
Trench 51							
General description					Orientation		N-S
Trench devoid of archaeology. Consists of ploughsoil and subsoil overlying natural geology of sandy gravel.					Length (m)		30
					Width (m)		2.1
					Avg. depth (m)		0.5
Context No.	Type	Fill Of	Width (m)	Depth (m)	Description	Finds	Date
5100	Layer		2.1	0.2	Ploughsoil. Mid brownish grey, sandy silt, friable		
5101	Layer		2.1	0.24	Subsoil. Mid greyish brown, sandy silt, soft		
5102	Layer		2.1		Natural. Light brownish red, sandy gravel, loose		
Trench 52							
General description					Orientation		NW-SE
Trench devoid of archaeology. Consists of ploughsoil overlying natural geology of sandy gravel.					Length (m)		30
					Width (m)		2.1
					Avg. depth (m)		0.4
Context No.	Type	Fill Of	Width (m)	Depth (m)	Description	Finds	Date
5200	Layer			0.3	Ploughsoil. Mid brownish grey silt with 10% <100mm sub rounded flint		
5201	Layer				Natural. Sub rounded flint gravel in light orangey brown silty sand matrix		
Trench 53							
General description					Orientation		NE-SW
Trench revealed a single ditch. Consists of ploughsoil overlying natural geology of gravely sand.					Length (m)		30
					Width (m)		2.1
					Avg. depth (m)		0.38
Context No.	Type	Fill Of	Width (m)	Depth (m)	Description	Finds	Date
5300	Layer			0.38	Ploughsoil. Mid brownish grey friable sandy silt		
5301	Layer				Natural. Sub rounded flint gravel in a mid orangey brown silty sand matrix		
5302	Cut		1.14	0.24	Ditch		
5303	Fill	5302	1.14	0.24	Primary Fill. Moderately compact, light orange brown silty sand		
Trench 54							
General description					Orientation		NE-SW
Trench devoid of archaeology. Consists of ploughsoil overlying natural geology sandy gravel.					Length (m)		30
					Width (m)		2.1
					Avg. depth (m)		0.4
Context No.	Type	Fill Of	Width (m)	Depth (m)	Description	Finds	Date

5400	Layer			0.3	Ploughsoil. Mid brownish grey silt with 10% <100mm sub rounded flint		
5401	Layer				Natural. Sub rounded flint gravel in light orangey brown silty sand matrix		
Trench 55							
General description					Orientation		NE-SW
Trench devoid of archaeology. Consists of ploughsoil and subsoil overlying natural geology of sandy gravel.					Length (m)		30
					Width (m)		2.1
					Avg. depth (m)		0.6
Context No.	Type	Fill Of	Width (m)	Depth (m)	Description	Finds	Date
5500	Layer		2.1	0.24	Ploughsoil. Dark brownish grey sandy silt friable		
5501	Layer		2.1	0.1	Subsoil. Mid reddish brown, sandy silt, soft		
5502	Layer		2.1		Natural. Light reddish brown, sandy gravel		
Trench 56							
General description					Orientation		NE-SW
Trench devoid of archaeology. Consists of ploughsoil overlying natural geology of sand and gravel.					Length (m)		30
					Width (m)		2.1
					Avg. depth (m)		0.36
Context No.	Type	Fill Of	Width (m)	Depth (m)	Description	Finds	Date
5600	Layer			0.36	Ploughsoil. Mid brownish grey friable sandy silt		
5601	Layer				Natural. Sub rounded flint gravel in a mid orangey brown silty sand matrix		
Trench 57							
General description					Orientation		E-W
Trench devoid of archaeology. Consists of ploughsoil overlying natural geology of sandy gravel.					Length (m)		30
					Width (m)		2.1
					Avg. depth (m)		0.38
Context No.	Type	Fill Of	Width (m)	Depth (m)	Description	Finds	Date
5700	Layer			0.38	Ploughsoil. Mid brownish grey friable sandy silt		
5701	Layer				Natural. Sub rounded flint gravel in a mid orangey brown silty sand matrix		
Trench 58							
General description					Orientation		N-S
Trench devoid of archaeology. Consists of ploughsoil overlying natural geology of silty sand and gravel.					Length (m)		30
					Width (m)		2.1
					Avg. depth (m)		0.38
Context No.	Type	Fill Of	Width (m)	Depth (m)	Description	Finds	Date
5800	Layer			0.38	Ploughsoil. Mid brownish grey friable sandy silt		



5801	Layer				Natural. Sub rounded flint gravel in a mid orangey brown silty sand matrix		
Trench 59							
General description					Orientation		
Trench not excavated					Length (m)		
					Width (m)		
					Avg. depth (m)		
Context No.	Type	Fill Of	Width (m)	Depth (m)	Description	Finds	Date
Trench 60							
General description					Orientation		
Trench not excavated					Length (m)		
					Width (m)		
					Avg. depth (m)		
Context No.	Type	Fill Of	Width (m)	Depth (m)	Description	Finds	Date
Trench 61							
General description					Orientation		
Trench not excavated					Length (m)		
					Width (m)		
					Avg. depth (m)		
Context No.	Type	Fill Of	Width (m)	Depth (m)	Description	Finds	Date
Trench 62							
General description					Orientation		E-W
Trench devoid of archaeology. Consists of a ploughsoil and colluvium overlying natural geology of sandy gravel.					Length (m)		30
					Width (m)		2.1
					Avg. depth (m)		0.85
Context No.	Type	Fill Of	Width (m)	Depth (m)	Description	Finds	Date
6200	Layer		2.1	0.25	Ploughsoil. Dark brownish grey, sandy silt, friable		
6201	Layer		2.1	0.6	Subsoil. Mid reddish brown, clayey silt, soft		
6202	Layer		2.1		Natural. Light reddish brown sandy gravel loose		
Trench 63							
General description					Orientation		N-S
Trench revealed a ditch at the southern end. Trench consists of a ploughsoil and colluvium overlying natural geology of sandy gravel.					Length (m)		30
					Width (m)		2.1
					Avg. depth (m)		0.8
Context No.	Type	Fill Of	Width (m)	Depth (m)	Description	Finds	Date

6300	Layer		2.1	0.26	Ploughsoil. Dark brownish grey, sandy silt, friable		
6301	Layer		2.1	0.45	Colluvial Layer. Mid reddish brown, clayey silt, soft. Possibly a subsoil.		
6302	Layer		2.1		Natural. Light reddish brown, sandy gravel, loose		
6303	Cut		0.51	0.16	Ditch		
6304	Fill	6303	0.51	0.16	Primary Fill. Light orange brown silty sand, moderately compact		

Trench 64

General description	Orientation	E-W
Trench revealed two pits and a N-S aligned ditch. Consists of ploughsoil and subsoil overlying natural geology of sandy gravel.	Length (m)	30
	Width (m)	2.1
	Avg. depth (m)	0.7

Context No.	Type	Fill Of	Width (m)	Depth (m)	Description	Findings	Date
6400	Layer		2.1	0.3	Ploughsoil. Dark brownish grey, sandy silt, friable		
6401	Layer		2.1	0.4	Colluvial Layer. Mid reddish brown, clayey silt, soft		
6402	Layer		2.1		Natural. Light reddish brown, sandy gravel, loose		
6403	Cut		0.59	0.5	Pit		
6404	Fill	6403	0.59	0.5	Deliberate Backfill. grey brown clayey sand with stones and burnt flint	Pot, Struck Flint, FC	MBA-IA
6405	Cut		0.42	0.14	Pit		
6406	Fill	6405	0.42	0.14	Deliberate Backfill. Grey brown loose silty sand	Burnt Flint	
6407	Cut		1.9	0.32	Ditch. N-S		
6408	Fill	6407	1.9	0.32	Primary Fill. Mottled grey compact silty sand		

Trench 65

General description	Orientation	N-S
Trench devoid of archaeology. Consists of ploughsoil overlying natural geology of sandy gravel.	Length (m)	30
	Width (m)	2.1
	Avg. depth (m)	0.5

Context No.	Type	Fill Of	Width (m)	Depth (m)	Description	Findings	Date
6500	Layer		2.1	0.36	Ploughsoil. Dark brownish grey, sandy silt, friable		
6501	Layer		2.1		Natural. Light reddish brown, sandy gravel, loose		

Trench 66

General description	Orientation	E-W
Trench devoid of archaeology. Consists of ploughsoil and subsoil overlying natural geology of sandy gravel	Length (m)	30
	Width (m)	2.1
	Avg. depth (m)	0.6

Context No.	Type	Fill Of	Width (m)	Depth (m)	Description	Finds	Date
6600	Layer		2.1	0.3	Ploughsoil. Dark brownish grey, sandy silt, friable		
6601	Layer		2.1	0.2	Subsoil. Mid reddish brown, sandy silt		
6602	Layer		2.1		Natural. Light reddish brown, sandy gravel, loose		

Trench 67

General description	Orientation	N-S
Trench devoid of archaeology. Consists ploughsoil and subsoil overlying natural geology of sandy gravel.	Length (m)	30
	Width (m)	2.1
	Avg. depth (m)	0.52

Context No.	Type	Fill Of	Width (m)	Depth (m)	Description	Finds	Date
6700	Layer		2.1	0.37	Ploughsoil. Dark brownish grey, sandy silt, friable		
6701	Layer		2.1	0.52	Subsoil. Mid reddish brown, sandy gravel, loose		
6702	Layer		2.1		Natural. Light reddish brown, sandy gravel, loose		

Trench 68

General description	Orientation	E-W
Trench devoid of archaeology. Consists of ploughsoil and subsoil overlying natural geology of sandy gravel.	Length (m)	30
	Width (m)	2.1
	Avg. depth (m)	0.48

Context No.	Type	Fill Of	Width (m)	Depth (m)	Description	Finds	Date
6800	Layer		2.1	0.39	Ploughsoil. Dark brownish grey, sandy silt, friable		
6801	Layer		2.1	0.48	Subsoil. Mid reddish brown, sandy gravel, loose		
6802	Layer		2.1		Natural. Light reddish brown, sandy gravel, loose		

Trench 69

General description	Orientation	N-S
Trench devoid of archaeology. Consists of ploughsoil and subsoil overlying natural geology of sandy gravel.	Length (m)	30
	Width (m)	2.1
	Avg. depth (m)	0.47

Context No.	Type	Fill Of	Width (m)	Depth (m)	Description	Finds	Date
6900	Layer		2.1	0.37	Ploughsoil. Dark brownish grey, sandy silt, friable		
6901	Layer		2.1	0.47	Subsoil. Mid reddish brown, sandy gravel, loose		
6902	Layer		2.1		Natural. Light reddish brown, sandy gravel, loose		

Trench 70

General description	Orientation	E-W
---------------------	-------------	-----

Trench devoid of archaeology. Consists ploughsoil and subsoil overlying natural geology of sandy gravel.						Length (m)		30
						Width (m)		2.1
						Avg. depth (m)		0.45
Context No.	Type	Fill Of	Width (m)	Depth (m)	Description	Finds	Date	
7000	Layer		2	0.38	Ploughsoil. Dark brownish grey, sandy silt, friable			
7001	Layer		2	0.45	Subsoil. Mid reddish brown, sandy gravel, loose			
7002	Layer		2		Natural. Light reddish brown, sandy gravel, loose			
Trench 71								
General description						Orientation		N-S
Trench devoid of archaeology. Trench consists of ploughsoil and subsoil overlying natural geology of sandy gravel.						Length (m)		30
						Width (m)		2.1
						Avg. depth (m)		0.49
Context No.	Type	Fill Of	Width (m)	Depth (m)	Description	Finds	Date	
7100	Layer		2	0.37	Ploughsoil. Dark brownish grey, sandy silt, friable			
7101	Layer		2.1	0.5	Subsoil. Mid reddish brown, sandy gravel, loose			
7102	Layer		2.1		Natural. Light reddish brown, sandy gravel, loose			
7103	Cut				Natural Feature. NW-SE pseudo-linear, irregular, uneven and shallow, filled with friable mid brown clayey sand			
Trench 72								
General description						Orientation		E-W
Trench devoid of archaeology. Consists of ploughsoil and subsoil overlying natural geology of sandy gravel.						Length (m)		30
						Width (m)		2.1
						Avg. depth (m)		0.52
Context No.	Type	Fill Of	Width (m)	Depth (m)	Description	Finds	Date	
7200	Layer		2.1	0.4	Ploughsoil. Dark brownish grey, sandy silt, friable			
7201	Layer		2.1	0.49	Subsoil. Mid reddish brown, sandy gravel, loose			
7202	Layer		2.1		Natural. Light reddish brown, sandy gravel, loose			
Trench 73								
General description						Orientation		N-S
Trench devoid of archaeology. Consists a ploughsoil and subsoil overlying natural geology of sandy gravel.						Length (m)		30
						Width (m)		2.1
						Avg. depth (m)		0.5
Context No.	Type	Fill Of	Width (m)	Depth (m)	Description	Finds	Date	
7300	Layer		2.1	0.4	Ploughsoil. Dark brownish grey, sandy silt, friable			

7301	Layer		2.1	0.5	Subsoil. Mid reddish brown, sandy gravel, loose		
7302	Layer		2.1	0.5	Natural. Light reddish brown, sandy gravel, loose		
7303	Cut		1.4	0.17	Natural Feature. "S" shaped feature, shallow, irregular base, filled with friable reddish brown sand		
7304	Cut				Pit		
7305	Cut		0.25	0.12	Ditch. Terminus, running NW-SE, shallow concave sided and base		
7306	Fill	7305	0.25	0.12	Secondary Fill. Mid grey brown silty sand, friable, pottery and stone inclusions		
7307	Cut				Natural Feature		

#### Trench 74

General description					Orientation	E-W
Trench devoid of archaeology. Trench consists of ploughsoil and subsoil overlying natural geology of sandy gravel.					Length (m)	30
					Width (m)	2
					Avg. depth (m)	0.46

Context No.	Type	Fill Of	Width (m)	Depth (m)	Description	Finds	Date
7400	Layer		2.1	0.39	Ploughsoil. Dark brownish grey, sandy silt, friable		
7401	Layer		2.1	0.46	Subsoil. Mid reddish brown, sandy gravel, loose		
7402	Layer		2.1		Natural. Light reddish brown, sandy gravel, loose		
7404	Cut		1.45	0.22	Natural Feature. Natural feature		
7407	Cut				Natural Feature. Natural feature tested.		

#### Trench 75

General description					Orientation	N-S
Trench devoid of archaeology. Consists of ploughsoil and subsoil overlying natural geology of sandy gravel.					Length (m)	30
					Width (m)	2.1
					Avg. depth (m)	0.63

Context No.	Type	Fill Of	Width (m)	Depth (m)	Description	Finds	Date
7500	Layer		2.1	30	Ploughsoil. Dark brownish grey, sandy silt, friable		
7501	Layer		2.1	0.63	Subsoil. Mid reddish brown, sandy gravel, loose		
7502	Layer		2.1		Natural. Light reddish brown, sandy gravel, loose		
7503	Cut				Natural Feature. Natural band of sand found at the eastern end of the trench.		

#### Trench 76

General description					Orientation	E-W
Trench devoid of archaeology. Consists of ploughsoil and subsoil overlying natural geology of sandy gravel.					Length (m)	30
					Width (m)	2.1
					Avg. depth (m)	0.62

Context No.	Type	Fill Of	Width (m)	Depth (m)	Description	Finds	Date
7600	Layer		2.1	0.38	Ploughsoil. Dark brownish grey, sandy silt, friable		
7601	Layer		2.1	0.62	Subsoil. Mid reddish brown, sandy gravel, loose		
7602	Layer		2.1		Natural. Light reddish brown, sandy gravel, loose		
7603	Layer		2.1		Natural. Dark brown red, silty sand, gravel, loose		

#### Trench 77

General description	Orientation	N-S
Trench revealed a single ditch in the middle of the trench running N/W-S/E. Consists of ploughsoil and subsoil overlying natural geology of sandy gravel.	Length (m)	30
	Width (m)	2.1
	Avg. depth (m)	0.52

Context No.	Type	Fill Of	Width (m)	Depth (m)	Description	Finds	Date
7700	Layer		2.1	0.41	Ploughsoil. Dark brownish grey, sandy silt, friable		
7701	Layer		2.1	0.57	Subsoil. Mid reddish brown, sandy gravel, loose		
7702	Layer		2.1		Natural. Light reddish brown, sandy gravel, loose		
7703	Cut		1.9	0.14	Ditch		
7704	Fill	7703	1.9	0.14	Primary Fill	Pot, Burnt Flint	MBA-IA

#### Trench 78

General description	Orientation	E-W
Trench devoid of archaeology. Consists of ploughsoil and subsoil overlying natural geology of sandy gravel.	Length (m)	30
	Width (m)	2.1
	Avg. depth (m)	0.56

Context No.	Type	Fill Of	Width (m)	Depth (m)	Description	Finds	Date
7800	Layer		2.1	0.37	Ploughsoil. Dark brownish grey, sandy silt, friable		
7801	Layer		2.1	0.56	Subsoil. Mid reddish brown, sandy gravel, loose		
7802	Layer		2.1	0.6	Natural. Light reddish brown, sandy gravel, loose		

#### Trench 79

General description	Orientation	N-S
Trench devoid of archaeology. Consists of ploughsoil and subsoil overlying natural geology of sandy gravel.	Length (m)	30
	Width (m)	2.1
	Avg. depth (m)	0.49

Context No.	Type	Fill Of	Width (m)	Depth (m)	Description	Finds	Date
7900	Layer		2.1	0.38	Ploughsoil. Dark brownish grey, sandy silt, friable		

7901	Layer		2.1	0.49	Subsoil. Mid reddish brown, sandy gravel, loose		
7902	Layer		2.1	0.53	Natural. Light reddish brown, sandy gravel, loose		
Trench 80							
General description					Orientation		E-W
Trench devoid of archaeology. Consists of ploughsoil and subsoil overlying natural geology of sandy gravel.					Length (m)		30
					Width (m)		2.1
					Avg. depth (m)		0.62
Context No.	Type	Fill Of	Width (m)	Depth (m)	Description	Finds	Date
8000	Layer		2.1	0.37	Ploughsoil. Dark brownish grey, sandy silt, friable		
8001	Layer		2.1	0.62	Subsoil. Mid reddish brown, sandy gravel, loose		
8002	Layer		2.1		Natural. Light reddish brown, sandy gravel, loose		
Trench 81							
General description					Orientation		N-S
Trench revealed a single pit in its central part. Consists of ploughsoil and subsoil overlying natural geology of sandy gravel.					Length (m)		30
					Width (m)		2.1
					Avg. depth (m)		0.55
Context No.	Type	Fill Of	Width (m)	Depth (m)	Description	Finds	Date
8100	Layer			0.35	Ploughsoil. Dark grey Clayey silt		
8101	Layer			0.25	Subsoil. Light greyish brown sandy silt		
8102	Layer				Natural. Sandy gravel		
8103	Cut		1.17	1.1	Pit. Overcut		
8104	Fill	8103	1.17	0.38	Primary Fill. Dark brown with grey mottling. Mod compact silty sand.		
8105	Fill	8103	1.17	0.3	Primary Fill		
8106	Fill	8103	1.25	0.24	Primary Fill		
Trench 82							
General description					Orientation		E-W
Trench devoid of archaeology. Consists of ploughsoil and subsoil overlying natural geology of sandy gravel.					Length (m)		30
					Width (m)		2.1
					Avg. depth (m)		0.47
Context No.	Type	Fill Of	Width (m)	Depth (m)	Description	Finds	Date
8200	Layer		2.1	0.39	Ploughsoil. Dark brownish grey, sandy silt, friable		
8201	Layer		2.1	0.47	Subsoil. Mid reddish brown, sandy gravel, loose		
8202	Layer		2.1		Natural. Light reddish brown, sandy gravel, loose		
Trench 83							

General description						Orientation		N-S
Trench devoid of archaeology. Consists of ploughsoil and subsoil overlying natural geology of sandy gravel.						Length (m)		30
						Width (m)		2.1
						Avg. depth (m)		0.46
Context No.	Type	Fill Of	Width (m)	Depth (m)	Description	Finds	Date	
8300	Layer		2.1	0.25	Ploughsoil. Dark brownish grey, sandy silt, friable			
8301	Layer		2.1	0.46	Subsoil. Mid reddish brown, sandy gravel, loose			
8302	Layer		2.1		Natural. Light reddish brown, sandy gravel, loose			

#### Trench 84

General description						Orientation		E-W
Trench devoid of archaeology. Consists of ploughsoil and subsoil overlying natural geology of sandy gravel.						Length (m)		30
						Width (m)		2.1
						Avg. depth (m)		0.37
Context No.	Type	Fill Of	Width (m)	Depth (m)	Description	Finds	Date	
8400	Layer		2.1	0.3	Ploughsoil. Dark brownish grey, sandy silt, friable			
8401	Layer		2.1	0.4	Subsoil. Mid reddish brown, sandy gravel, loose			
8402	Layer		2.1		Natural. Light reddish brown, sandy gravel, loose			

#### Trench 85

General description						Orientation		NE-SW
Trench devoid of archaeology. Consists of ploughsoil and subsoil overlying natural geology of sandy gravel.						Length (m)		30
						Width (m)		2.1
						Avg. depth (m)		0.49
Context No.	Type	Fill Of	Width (m)	Depth (m)	Description	Finds	Date	
8500	Layer		2.1	0.3	Ploughsoil. Mid brownish grey, silty sand, friable			
8501	Layer		2.1	0.19	Subsoil. Mid orangey brown silty sand, friable, occasional fleck of stone inclusion			
8502	Layer		2.1		Natural. Mid reddish brown silty sand with occasional gravel patches, firm			

#### Trench 86

General description						Orientation		N-S
Trench devoid of archaeology. Consists of ploughsoil and subsoil overlying natural geology of sandy silt.						Length (m)		30
						Width (m)		1.2
						Avg. depth (m)		0.4
Context No.	Type	Fill Of	Width (m)	Depth (m)	Description	Finds	Date	
8600	Layer		2.1	0.2	Ploughsoil. Dark brownish grey, sandy silt, friable			
8601	Layer		2.1	0.4	Subsoil. Mid greyish brown, sandy silt, loose			



8602	Layer		2.1		Natural. Light yellow brown, sandy silt, friable		
Trench 87							
General description					Orientation		E-W
One shallow ditch Consists of ploughsoil and subsoil overlying natural geology of sandy silt.					Length (m)		30
					Width (m)		2.1
					Avg. depth (m)		0.39
Context No.	Type	Fill Of	Width (m)	Depth (m)	Description	Finds	Date
8700	Layer		2.1	0.32	Ploughsoil. Mid brown grey silty sand, friable		
8701	Layer		2.1	0.2	Subsoil. Mid orange brown silty sand, friable		
8702	Layer		2.1		Natural. Mid reddish brown, silty sand, with gravelly patches, friable		
8703	Cut		1.02	0.24	Ditch		
8704	Fill	8703	1.02	0.24	Primary Fill. Mid greyish brown moderately friable sandy silt	Struck Flint	
Trench 88							
General description					Orientation		N-S
Trench devoid of archaeology. Consists of ploughsoil and subsoil overlying natural geology of sandy silt.					Length (m)		30
					Width (m)		2.1
					Avg. depth (m)		0.45
Context No.	Type	Fill Of	Width (m)	Depth (m)	Description	Finds	Date
8800	Layer		2.1	0.2	Ploughsoil. Dark brownish grey, sandy silt, friable		
8801	Layer		2.1	0.45	Subsoil. Mid greyish brown, sandy silt, loose		
8802	Layer		2.1		Natural. Light yellow brown, sandy silt, friable		
Trench 89							
General description					Orientation		E-W
Trench devoid of archaeology. Consists of ploughsoil and subsoil overlying natural geology of sandy silt.					Length (m)		30
					Width (m)		2.1
					Avg. depth (m)		0.4
Context No.	Type	Fill Of	Width (m)	Depth (m)	Description	Finds	Date
8900	Layer		2.1	0.32	Ploughsoil. Mid brown grey silty sand with rooting and fragmented stone inclusions		
8901	Layer		2.1	0.2	Subsoil. Mid orange brown, silty sand, with occasional fragmented stone inclusion, friable		
8902	Layer		2.1		Natural. Mid reddish brown, silty sand with occasional gravel inclusions, firm		
8903	Cut				Natural Feature. Natural Feature		
Trench 90							
General description					Orientation		N-S

Trench devoid of archaeology. Consists of ploughsoil and subsoil overlying natural geology of sandy silt.						Length (m)		30
						Width (m)		2.1
						Avg. depth (m)		0.38
Context No.	Type	Fill Of	Width (m)	Depth (m)	Description	Finds	Date	
9000	Layer		2.1	0.27	Ploughsoil. Dark brownish grey, sandy silt, friable			
9001	Layer		2.1	0.38	Subsoil. Mid greyish brown, sandy silt, loose			
9002	Layer		2.1		Natural. Light yellow brown, sandy silt, friable			
Trench 91								
General description						Orientation		E-W
Trench devoid of archaeology. Consists of ploughsoil and subsoil overlying natural geology of sandy silt.						Length (m)		30
						Width (m)		2.1
						Avg. depth (m)		0.41
Context No.	Type	Fill Of	Width (m)	Depth (m)	Description	Finds	Date	
9100	Layer		2.1	0.23	Ploughsoil. Dark brownish grey, sandy silt, friables			
9101	Layer		2.1	0.41	Subsoil. Mid greyish brown, sandy silt, loose			
9102	Layer		2.1	0.6	Natural. Light yellow brown, sandy silt, friable			
Trench 92								
General description						Orientation		N-S
Trench devoid of archaeology. Consists of ploughsoil and subsoil overlying natural geology of sandy silt.						Length (m)		30
						Width (m)		2.1
						Avg. depth (m)		0.43
Context No.	Type	Fill Of	Width (m)	Depth (m)	Description	Finds	Date	
9200	Layer		2.1	0.22	Ploughsoil. Dark brownish grey, sandy silt, friable			
9201	Layer		2.1	0.43	Subsoil. Mid greyish brown, sandy silt, loose			
9202	Layer		2.1		Natural. Light yellow brown, sandy silt, friable			
Trench 93								
General description						Orientation		E-W
Trench devoid of archaeology. Consists of ploughsoil and subsoil overlying natural geology of sandy gravel.						Length (m)		30
						Width (m)		2.1
						Avg. depth (m)		0.42
Context No.	Type	Fill Of	Width (m)	Depth (m)	Description	Finds	Date	
9300	Layer		2.1	0.21	Ploughsoil. Dark brownish grey, sandy silt, friable			
9301	Layer		2.1	0.42	Subsoil. Mid grayish brown, sandy silt, loose			

9302	Layer		2.1		Natural. Light yellow brown, sandy silt, friable		
Trench 94							
General description					Orientation		N-S
Trench devoid of archaeology. Consists of ploughsoil and subsoil overlying natural geology of sandy silt.					Length (m)		30
					Width (m)		2.1
					Avg. depth (m)		0.37
Context No.	Type	Fill Of	Width (m)	Depth (m)	Description	Finds	Date
9400	Layer		2.1	0.18	Ploughsoil. Dark brownish grey, sandy silt, friable		
9401	Layer		2.1	0.37	Subsoil. Mid greyish brown, sandy silt, loose		
9402	Layer		2.1		Natural. Light yellow brown, sandy silt, friable		
Trench 95							
General description					Orientation		E-W
Trench devoid of archaeology. Consists of ploughsoil and subsoil overlying natural geology of sandy silt.					Length (m)		30
					Width (m)		2.1
					Avg. depth (m)		0.41
Context No.	Type	Fill Of	Width (m)	Depth (m)	Description	Finds	Date
9500	Layer		2.1	0.3	Ploughsoil. Dark brownish grey, sandy silt, friables		
9501	Layer		2.1	0.2	Subsoil. Mid greyish brown, sandy silt, loose		
9502	Layer		2.1		Natural. Light yellow brown, sandy silt, friable		
Trench 96							
General description					Orientation		NW-SE
Trench devoid of archaeology. Consists of ploughsoil and subsoil overlying natural geology of sandy gravel.					Length (m)		30
					Width (m)		2.1
					Avg. depth (m)		0.49
Context No.	Type	Fill Of	Width (m)	Depth (m)	Description	Finds	Date
9600	Layer		2.1	0.36	Ploughsoil. Dark brownish grey, sandy silt, friables		
9601	Layer		2.1	0.4	Subsoil. Mid greyish brown, sandy gravel, loose		
9602	Layer		2.1		Natural. Light yellow brown, sandy silt, friable		
9603	Void						
Trench 97							
General description					Orientation		N-S
Trench devoid of archaeology. Consists of ploughsoil and subsoil overlying natural geology of sandy gravel.					Length (m)		30
					Width (m)		2.1
					Avg. depth (m)		0.36

Context No.	Type	Fill Of	Width (m)	Depth (m)	Description	Finds	Date
9700	Layer		2.1	0.19	Ploughsoil. Dark brownish grey, sandy silt, friables		
9701	Layer		2.1	0.36	Subsoil. Mid greyish brown, sandy silt, loose		
9702	Layer		2.1		Natural. Light yellow brown, sandy gravel, loose		

#### Trench 98

General description	Orientation	E-W
Two possible ditches. Consists of ploughsoil and subsoil overlying natural geology of sandy silt.	Length (m)	30
	Width (m)	2.1
	Avg. depth (m)	0.48

Context No.	Type	Fill Of	Width (m)	Depth (m)	Description	Finds	Date
9800	Layer		2.1	0.4	Ploughsoil. Dark brownish grey, sandy silt, friable		
9801	Layer		2.1	0.09	Subsoil. Mid greyish brown, sandy silt, loose		
9802	Layer		2.1		Natural. Light yellow brown, sandy silty gravel, friable		
9803	Cut				Natural Feature. Slightly darker reddish brown natural. No definitive edges and nothing visible in section		
9804	Cut		0.8	0.22	Ditch. N-S oriented shallow ditch		
9805	Fill	9804	0.8	0.22	Primary Fill. Mid greyish brown sandy silt		
9806	Cut		1.04	0.4	Ditch. N-S oriented possible ditch		
9807	Fill	9806	1.04	0.4	Primary Fill. Mid greyish brown gravelly silt		

#### Trench 99

General description	Orientation	N-S
Trench devoid of archaeology. Consists of ploughsoil and subsoil overlying natural geology of sandy gravel.	Length (m)	30
	Width (m)	2.1
	Avg. depth (m)	0.38

Context No.	Type	Fill Of	Width (m)	Depth (m)	Description	Finds	Date
9900	Layer		2.1	0.17	Ploughsoil. Dark brownish grey, sandy silt, friables		
9901	Layer		2.1	0.38	Subsoil. Mid greyish brown, sandy silt, loose		
9902	Layer		2.1		Natural. Light yellow brown, sandy silty gravel, friable		

#### Trench 100

General description	Orientation	E-W
Trench devoid of archaeology. Consists of ploughsoil and subsoil overlying natural geology of sandy silt.	Length (m)	30
	Width (m)	2.1
	Avg. depth (m)	0.35

Context No.	Type	Fill Of	Width (m)	Depth (m)	Description	Finds	Date
10000	Layer			0.3	Ploughsoil. Grey brown sandy silt		

10001	Layer			0.05	Subsoil. Greyish brown, sandy silt		
10002	Layer				Natural. Light yellow brown silty sand		
Trench 101							
General description					Orientation		NW-SE
Trench devoid of archaeology. Consists of ploughsoil and subsoil overlying natural geology of sandy gravel.					Length (m)		30
					Width (m)		2.1
					Avg. depth (m)		0.38
Context No.	Type	Fill Of	Width (m)	Depth (m)	Description	Finds	Date
10100	Layer		2.1	0.18	Ploughsoil. Dark brownish grey, sandy silt, friables		
10101	Layer		2.1	0.38	Subsoil. Mid greyish brown, sandy silt, loose		
10102	Layer		2.1		Natural. Light yellow brown, sandy gravel, loose		
Trench 102							
General description					Orientation		NE-SW
Trench devoid of archaeology. Consists of ploughsoil and subsoil overlying natural geology of sandy silt.					Length (m)		30
					Width (m)		2.1
					Avg. depth (m)		0.36
Context No.	Type	Fill Of	Width (m)	Depth (m)	Description	Finds	Date
10200	Layer		2.1	0.19	Ploughsoil. Dark brownish grey, sandy silt, friable		
10201	Layer		2.1	0.36	Natural. Mid greyish brown, sandy silt, loose		
10202	Layer		2.1		Natural. Light yellow brown, sandy gravel, loose		
Trench 103							
General description					Orientation		SW-NE
Trench devoid of archaeology. Consisted of ploughsoil over subsoil overlying gravelly sand natural.					Length (m)		30
					Width (m)		2
					Avg. depth (m)		0.45
Context No.	Type	Fill Of	Width (m)	Depth (m)	Description	Finds	Date
10300	Layer		2	0.26	Ploughsoil. Dark grey mod compact sandy silt		
10301	Layer		2	0.13	Subsoil. Dark greyish brown sandy silt		
10302	Layer		2		Natural. Orangey brown gravelly sand		
10303	Cut		1.54	0.23	Natural Feature. Natural feature. Light grey sand		
10304	Cut		1.51	0.21	Natural Feature. Light grey sand		
Trench 104							
General description					Orientation		NE-SW
Trench devoid of archaeology. Consists of ploughsoil and subsoil overlying natural geology of gravels and silty sand.					Length (m)		30
					Width (m)		2.3

						Avg. depth (m)	0.45
Context No.	Type	Fill Of	Width (m)	Depth (m)	Description	Finds	Date
10400	Layer			0.25	Ploughsoil. Mid brownish grey sandy silt.		
10401	Layer			0.2	Subsoil. Mid brownish orange silty sand.		
10402	Layer				Natural. Natural gravel with patches of orange sand		
Trench 105							
General description						Orientation	E-W
Trench devoid of archaeology. Consists of ploughsoil and subsoil overlying natural geology of gravels and silty sand.						Length (m)	30
						Width (m)	2.3
						Avg. depth (m)	0.45
Context No.	Type	Fill Of	Width (m)	Depth (m)	Description	Finds	Date
10500	Layer			0.25	Ploughsoil. Mid greyish brown sandy silt.		
10501	Layer			0.2	Subsoil. Mid orangish brown sandy silt.		
Trench 106							
General description						Orientation	N-S
Trench revealed a single ditch. Consists of ploughsoil and subsoil overlaying a slightly gravel and clay natural.						Length (m)	30
						Width (m)	2.1
						Avg. depth (m)	0.45
Context No.	Type	Fill Of	Width (m)	Depth (m)	Description	Finds	Date
10600	Layer			0.23	Ploughsoil. Loose sandy silt		
10601	Layer			0.1	Subsoil. Light grey mod compact sandy silt		
10602	Layer		2		Natural. Orangey clayey sand		
10603	Cut		2.05	0.35	Ditch. Runs E/W		
10604	Fill	10603	2.05	0.35	Primary Fill. Light grey mod compact sandy silt		
Trench 107							
General description						Orientation	N-S
Trench revealed a single ditch. Consists of ploughsoil and subsoil overlying a natural of sandy gravel.						Length (m)	30
						Width (m)	2.2
						Avg. depth (m)	0.28
Context No.	Type	Fill Of	Width (m)	Depth (m)	Description	Finds	Date
10700	Layer		2.2	0.26	Ploughsoil. Mid grey brown, silty sand, friable		
10701	Layer		2.2	0.12	Subsoil. Mid yellowish brown, sandy silt, soft		
10702	Layer		2.2		Natural. Mid yellowish brown, sandy gravel, loose		
10703	Cut		1.04	0.32	Ditch. Curvilinear		
10704	Fill	10703	0.7	0.1	Primary Fill. Dark greyish brown, sandy gravel, loose		

10705	Fill	10703	1.04	0.22	Secondary Fill. Mid greyish brown, sandy clay, firm		
Trench 108							
General description					Orientation		E-W
Trench revealed a single ditch. Consists of ploughsoil overlaying a natural of light reddish brown gravelly, sandy clay.					Length (m)		30
					Width (m)		2.3
					Avg. depth (m)		0.4
Context No.	Type	Fill Of	Width (m)	Depth (m)	Description	Finds	Date
10800	Layer		2.1	0.26	Ploughsoil. dark greyish brown		
10801	Layer		2.1	0.14	Natural. Light reddish brown sandy silty, gravel		
10802	Cut		0.6	0.22	Ditch. linear, very shallow, running NW-SE		
10803	Fill	10802	0.6	0.22	Secondary Fill. mid reddish brown sandy silt, gravel		
10804	Cut		0.6	0.08	Natural Feature. Light brown patch, silty sand, with small gravel. Looked like a pos linear.		
Trench 109							
General description					Orientation		NE-SW and NW-SE
Trench revealed two ditches and 8 pits. One of the pits in the central part of the trench contains an in-situ pottery vessel. Consists of ploughsoil and subsoil overlying an orange gravelly sand natural.					Length (m)		50
					Width (m)		2
					Avg. depth (m)		0.42
Context No.	Type	Fill Of	Width (m)	Depth (m)	Description	Finds	Date
10900	Layer			0.3	Topsoil. Mid grey brown, moderately compact silty sand		
10901	Layer			0.16	Subsoil. Mid yellowish brown, moderately friable silty sand		
10902	Layer				Natural. Light yellowish orange, moderately friable gravelly sand		
10903	Cut		0.64	0.24	Pit		
10904	Fill	10903	0.64	0.24	Primary Fill. Mid greyish brown, friable gravelly sand.		
10905	Cut		1.16	0.42	Pit		
10906	Fill	10905	1.16	0.42	Primary Fill. Friable mid greyish brown, gravelly sand		
10907	Layer			0.44	Other Layer. Light to mid grey, gravelly silt layer south of the trench. Test pit through it.		
10908	Cut		0.82	0.46	Ditch		
10909	Fill	10908	0.82	0.46	Primary Fill. Friable mid greyish brown, gravelly sand		
10910	Cut		4.86	0.65	Ditch. SE/NW		
10911	Fill	10908		0.26	Primary Fill. Light brownish grey sandy silt		
10912	Fill	10910		0.34	Secondary Fill. Dark brown mod compact sandy silt	Pot, FC	c 970-1100

10913	Cut		0.7	0.4	Ring Ditch. Slightly over machined possible overall depth 0.50m		
10914	Fill	10913	0.7	0.4	Secondary Fill. Mid Brown grey, silty sand, gravel stones.		
10915	Cut		1.2	0.2	Pit.		
10916	Fill	10915	1.2	0.2	Secondary Fill. Mid Brown grey, silty, sand, small gravel like stones. Slightly overcut base.		
10917	Cut		0.5	0.35	Cremation Cut.		
10918	Fill	10917	0.5	0.25	Cremation Deposit. Dark black, small fragments of bone and gravel stones.		
10919	Fill	10917	0.5	0.1	Secondary Fill. Mid brown grey, silty, sand with gravel stones		
10920	Unexcavated feature		0.3		Cremation Cut. Dark brown		
10921	Unexcavated feature		0.3		Pit. Mid brown grey		
10922	Unexcavated feature		1		Pit. Mid greyish brown, moderately friable gravelly silty sand. Half in the LOE of trench		
10923	Layer			0.12	Other Layer. Redeposited natural in test pit. Mottled yellowish orange loose gravelly sand and lenses of dark greyish brown gravelly sand		
10924	Layer		50		Other Layer. Darker layer in test pit, on top of 10907. Friable dark greyish brown gravelly sand		
10925	Unexcavated feature		0.5		Pit. Unexcavated pit with in-situ complete pot in it.	Pot	MBA-IA
10926	Cut		0.43		Pit. Unexcavated feature		

#### Trench 110

General description		Orientation	NW-SE
Trench revealed a ditch at the NW end. Consists of ploughsoil covering an orange gravelly sand natural.		Length (m)	30
		Width (m)	2
		Avg. depth (m)	0.34

Context No.	Type	Fill Of	Width (m)	Depth (m)	Description	Finds	Date
11000	Layer		2	0.33	Ploughsoil. Dark grey mod compact sandy silt		
11001	Layer		2		Natural. Loose orange gravelly sand		
11002	Cut		2.6	0.6	Ditch. NE/SW. Not fully excavated due to depth		
11003	Fill	11002	2.6	0.6	Primary Fill. Light grey mod compact sandy silt		

#### Trench 111

General description		Orientation	E-W
Trench devoid of archaeology. Consists of ploughsoil overlaying natural geology of silty sand and gravel.		Length (m)	30
		Width (m)	2.2
		Avg. depth (m)	0.28

Context No.	Type	Fill Of	Width (m)	Depth (m)	Description	Finds	Date
-------------	------	---------	-----------	-----------	-------------	-------	------



11100	Layer		2.2	0.28	Ploughsoil. Mid grey brown silty sand, friable		
11101	Layer		2.2		Natural. Mid yellowish brown, silty sand, with gravel throughout, firm		
Trench 112							
General description					Orientation		N-S
Trench devoid of archaeology. Consists of ploughsoil overlaying gravelly natural					Length (m)		30
					Width (m)		2.2
					Avg. depth (m)		0.27
Context No.	Type	Fill Of	Width (m)	Depth (m)	Description	Finds	Date
11200	Layer		2.2	0.26	Ploughsoil. Mid grey brown silty sand, friable		
11201	Layer		2.2	0.26	Natural. Mid yellowish orange, silty sand with gravel throughout		
Trench 113							
General description					Orientation		NW-SE
Trench devoid of archaeology. Consists of ploughsoil and subsoil overlying natural geology of brown sandy clay with outcrops of gravel.					Length (m)		30
					Width (m)		2.3
					Avg. depth (m)		0.55
Context No.	Type	Fill Of	Width (m)	Depth (m)	Description	Finds	Date
11300	Layer			0.3	Ploughsoil. Mid brownish grey sandy silt.		
11301	Layer			0.25	Subsoil. Light orangish brown sandy silt.		
11302	Layer				Natural. Natural geology of brown sandy silt with outcrops of gravel.		
Trench 114							
General description					Orientation		E-W
Trench devoid of archaeology. Consists of ploughsoil overlaying natural					Length (m)		30
					Width (m)		2.1
					Avg. depth (m)		0.4
Context No.	Type	Fill Of	Width (m)	Depth (m)	Description	Finds	Date
11400	Layer		2.1	0.4	Ploughsoil. Mid grey brown silty sand with rounded stones and rooting inclusions		
11401	Layer		2.1		Natural. Mid reddish orangey brown silty gravelly, friable		
11402	Cut		2.13		Natural Feature. Natural feature. Loose grey gravelly sand		
Trench 115							
General description					Orientation		N-S
Trench revealed two ditches. Consists of ploughsoil overlying natural geology of gravel and sand.					Length (m)		30
					Width (m)		2.1
					Avg. depth (m)		0.33
Context No.	Type	Fill Of	Width (m)	Depth (m)	Description	Finds	Date

11500	Layer				Ploughsoil. Dark brown, clay		
11501	Layer				Natural		
11502	Cut		0.43	0.09	Ditch		
11503	Fill	11502	0.43	0.09	Primary Fill. Mid brown grey, sandy clay.		
11504	Unexcavated feature		0.55		Ditch. NE/SW orientated, containing a light greyish brown sandy silt fill. No surface finds recovered.		

Trench 116

General description					Orientation	NW-SE
Trench revealed one ditch and one pit. Consists of ploughsoil and subsoil overlying natural gravel.					Length (m)	30
					Width (m)	2.1
					Avg. depth (m)	0.4

Context No.	Type	Fill Of	Width (m)	Depth (m)	Description	Finds	Date
11600	Layer		2	0.29	Ploughsoil. Dark brown clayey silt		
11601	Layer		2	0.13	Subsoil. Mid brown clayey silt		
11602	Layer		2		Natural. Sandy Gravel		
11603	Cut		0.89	0.27	Ditch. NW/SE		
11604	Fill	11603	0.89	0.27	Primary Fill. Dark greyish brown loose sandy silt		
11605	Cut		0.39	0.14	Pit. Cut by 11603		
11606	Fill	11605	0.39	0.14	Deliberate Backfill. Dark brown mod compact clayey silt. Env sample S.2		
11607	Cut		1.1	0.38	Natural Feature. Natural feature.		

Trench 117

General description					Orientation	NW-SE
Trench revealed one ditch. Consists of ploughsoil and subsoil overlying natural geology of gravel.					Length (m)	30
					Width (m)	2.1
					Avg. depth (m)	0.49

Context No.	Type	Fill Of	Width (m)	Depth (m)	Description	Finds	Date
11700	Layer		2.1	0.4	Ploughsoil		
11701	Layer		2.1	0.09	Subsoil		
11702	Layer		2.1		Natural		
11703	Cut		1	0.26	Ditch		
11704	Fill	11703	1	0.26	Primary Fill		
11705	Cut		1.34	0.4	Ditch		
11706	Fill	11705	1.34	0.4	Primary Fill		

Trench 118

General description					Orientation	NW-SE
Trench revealed a ditch. Consists of ploughsoil and a thin layer of subsoil overlying gravelled natural					Length (m)	30
					Width (m)	2.1
					Avg. depth (m)	0.49

Context No.	Type	Fill Of	Width (m)	Depth (m)	Description	Finds	Date
-------------	------	---------	-----------	-----------	-------------	-------	------

11800	Layer		2.1	0.4	Ploughsoil		
11801	Layer		2.1	0.12	Subsoil		
11802	Layer		2.1		Natural		
11803	Cut		0.8	0.37	Ditch. NE-SW Running slightly curvilinear ditch. Moderately sloping concave sides and a concave base.		

Trench 119

General description					Orientation		NE-SW
Trench devoid of archaeology. Consists of ploughsoil covering gravel natural.					Length (m)		30
					Width (m)		2.1
					Avg. depth (m)		0.3

Context No.	Type	Fill Of	Width (m)	Depth (m)	Description	Finds	Date
11900	Layer		2.1	0.3	Ploughsoil. Mid grey brown, silty sand, friable with rooting and rounded stone inclusions		
11901	Layer		2.1		Natural. Light yellowish brown, silty sand with large quantities of gravel throughout		

Trench 120

General description					Orientation		L-shaped trench
Trench revealed two parallel NE/SW orientated ditches. Consists of ploughsoil and subsoil overlying a sandy gravel natural					Length (m)		30
					Width (m)		2.3
					Avg. depth (m)		0.44

Context No.	Type	Fill Of	Width (m)	Depth (m)	Description	Finds	Date
12000	Layer		2	0.29	Ploughsoil. Dark grey loose sandy silt		
12001	Layer		2	0.11	Subsoil. Light grey loose sandy silt		
12002	Layer		2		Natural. Sandy gravel		
12003	Cut		0.66	0.15	Ditch. E/W		
12004	Fill	12003	0.66	0.14	Primary Fill. Light grey loose gravelly sand		
12005	Cut		0.62	0.12	Ditch. Runs E/W. Parallel to 12003		
12006	Fill	12005	0.62	0.12	Primary Fill. Light grey loose gravelly sand		
12007	Cut		0.3	0.07	Plough Furrow. Plough scar		

Trench 121

General description					Orientation		NW-SE
Trench revealed two parallel NE/SE aligned ditches. Ploughsoil overlying natural geology of gravels and silty sand.					Length (m)		30
					Width (m)		2.3
					Avg. depth (m)		0.35

Context No.	Type	Fill Of	Width (m)	Depth (m)	Description	Finds	Date
12100	Layer		2.3	0.3	Ploughsoil. Dark brown silty sand.		
12101	Layer				Natural. Gravels and silty sand.		
12102	Cut				Ditch		
12103	Fill	12102			Primary Fill. Greyish brown sandy silt.		

12104	Cut				Ditch		
12105	Fill	12104			Secondary Fill. greyish brown sandy silt		
Trench 122							
General description					Orientation		NW-SE
Trench revealed 2 ditches. Consists of ploughsoil overlaying natural.					Length (m)		30
					Width (m)		2.1
					Avg. depth (m)		0.4
Context No.	Type	Fill Of	Width (m)	Depth (m)	Description	Finds	Date
12200	Layer			0.3	Ploughsoil. Dark grey loose sandy silt		
12201	Layer				Natural. Orange gravelly sand		
12202	Cut		1.31	0.25	Ditch. NE/SW		
12203	Fill	12202	1.31	0.25	Primary Fill. Light grey mod compact sandy sily		
12204	Cut		1.65	0.51	Ditch. E/W		
12205	Fill	12204	1.65	0.51	Primary Fill. Light greyish brown sandy silt	CBM	?Roman
Trench 123							
General description					Orientation		NE-SW
Trench revealed two pits. Consists of ploughsoil and subsoil overlying natural geology of silty sand and gravel.					Length (m)		30
					Width (m)		
					Avg. depth (m)		0.4
Context No.	Type	Fill Of	Width (m)	Depth (m)	Description	Finds	Date
12300	Layer			0.4	Topsoil. Mid greyish brown, moderately compact silty clay. Plough soil		
12301	Layer			0.08	Subsoil. Mid reddish brown, moderately compact silty clay		
12302	Layer				Natural. Light orange yellow, compact clay		
12303	Cut		0.66	0.22	Pit. Bronze age		
12304	Fill	12303	0.68	0.1	Primary Fill. Mid greyish yellow silty clay		
12305	Fill	12303	0.62	0.18	Secondary Fill. Mid greyish brown, silty clay	Pot	MBA/LBA
12306	Cut		0.8	0.58	Pit. Large bronze age pit		
12307	Fill	12306	0.8	0.58	Deliberate Backfill. Dark brownish grey, moderately compact silty clay	Pot, Struck Flint, FC	MBA
12308	Cut		0.5	0.32	Pit. Small bronze age pit cutting pit 12306		
12309	Fill	12308		0.1	Primary Fill. Light yellow silty clay		
12310	Fill	12308		0.22	Secondary Fill. Dark brownish grey, moderately compact silty clay. Deliberate backfill. Env sample S.3.	Pot, Struck Flint, Burnt Flint	MBA/LBA
12311	Fill	12308		0.11	Tertiary Fill. Light yellow silty clay		
12312	Cut		1.52	0.18	Ditch. Ditch or natural hollow		
12313	Fill	12312	1.52	0.18	Primary Fill. Mid yellowish brown, moderately compact silty clay, occasional	Pot	50BC-AD 70

					charcoal flakes, CBM and small sub angular stones		
Trench 124							
General description						Orientation	
Trench not excavated						Length (m)	
						Width (m)	
						Avg. depth (m)	
Context No.	Type	Fill Of	Width (m)	Depth (m)	Description	Finds	Date
Trench 125							
General description						Orientation	
Trench not excavated						Length (m)	
						Width (m)	
						Avg. depth (m)	
Context No.	Type	Fill Of	Width (m)	Depth (m)	Description	Finds	Date
Trench 126							
General description						Orientation	
Trench not excavated						Length (m)	
						Width (m)	
						Avg. depth (m)	
Context No.	Type	Fill Of	Width (m)	Depth (m)	Description	Finds	Date
Trench 127							
General description						Orientation	
Trench devoid of archaeology. Consists of ploughsoil and subsoil overlying natural geology of gravel and sands.						Length (m)	
						Width (m)	
						Avg. depth (m)	
Context No.	Type	Fill Of	Width (m)	Depth (m)	Description	Finds	Date
12700	Layer			0.4	Ploughsoil. Mid brownish grey sandy silt with frequent gravel.		
12701	Layer			0.2	Subsoil. Mid reddish brown sandy silt.		
12702	Layer			0.35	Colluvial Layer. Light yellowish brown sandy silt.		
12703	Layer				Natural. Gravel with frequent patches of orange silty sand.		
Trench 128							
General description						Orientation	
Trench contained several archaeological features and possible quarrying feature at the eastern end. Consisted of ploughsoil overlying subsoil and natural.						Length (m)	
						Width (m)	
						Avg. depth (m)	
Context No.	Type	Fill Of	Width (m)	Depth (m)	Description	Finds	Date

12800	Layer		2.3	0.2	Ploughsoil. Mid brownish grey		
12801	Layer		2.3	0.3	Subsoil. Mid reddish brown, silty sand, gravel inclusions		
12802	Layer		2.3	0.2	Natural. Light yellowish orange, silty sandy, gravel inclusions.		
12803	Cut		0.8	0.12	Pit		
12804	Fill	12803	0.8	0.12	Secondary Fill. Mid brownish grey, silty sand gravel inclusions		
12805	Cut		0.3	0.1	Posthole. Unsure whether is posthole or cremation?		
12806	Fill	12805	0.3	0.08	Deliberate Backfill. Black charcoal-rich fill. Env. Sample S.5	Burnt Flint	
12807	Fill	12805	0.3	0.02	Secondary Fill. Mid grey brown, stone inclusions		
12808	Cut		2.5	0.3	Ditch. Unable to chase full width of feature due to the end of trench. Slope.		
12809	Fill	12808	2.5	0.2	Primary Fill. Mid brown, sandy silt. Minimal stone inclusions.	Pot	MBA-IA
12810	Fill	12808	3.2	0.1	Secondary Fill. Mid grey brown, silty sand with mixture of large medium stone inclusions.		
12811	Layer		4.1	0.42	Colluvial Layer. Mid brown, sandy silt, compact.		

Trench 129

General description		Orientation	NW-SE
Trench devoid of archaeology. Consists of ploughsoil, colluvium and natural geology of sandy silt.		Length (m)	30
		Width (m)	2.3
		Avg. depth (m)	0.75

Context No.	Type	Fill Of	Width (m)	Depth (m)	Description	Finds	Date
12900	Layer			0.3	Ploughsoil. Loose dark brownish grey sandy silt.		
12901	Layer			0.45	Colluvial Layer. Light brown sandy silt with.		
12902	Layer				Natural. Light greyish yellow and mid reddish brown sandy silt.		

Trench 130

General description		Orientation	NW-SE
Trench devoid of archaeology, consists of ploughsoil colluvium and natural geology of sandy silt with outcrops of gravel.		Length (m)	30
		Width (m)	2.3
		Avg. depth (m)	0.9

Context No.	Type	Fill Of	Width (m)	Depth (m)	Description	Finds	Date
13000	Layer			0.4	Ploughsoil. Dark greyish brown sandy silt		
13001	Layer			0.55	Colluvial Layer. Mid brown sandy silt with frequent gravel.		
13002	Layer				Natural. Light reddish brown sandy silt.		
13003	Layer				Natural. Edge of natural gravel partially identified in the northern part of the trench.		

Trench 131

General description						Orientation		NW-SE	
Trench devoid of archaeology. Consists of ploughsoil, colluvium and natural geology of silty sand.						Length (m)		30	
						Width (m)		2.3	
						Avg. depth (m)		0.65	
Context No.	Type	Fill Of	Width (m)	Depth (m)	Description	Finds	Date		
13100	Layer			0.35	Ploughsoil. Dark greyish brown sandy silt				
13101	Layer			0.45	Colluvial Layer. Light yellowish brown sandy silt.				
13102	Layer				Natural. Light yellowish brown silty sand.				
Trench 132									
General description						Orientation		N-S	
Trench devoid of archaeology. Consists of ploughsoil overlaying natural						Length (m)		30	
						Width (m)		2.1	
						Avg. depth (m)		0.6	
Context No.	Type	Fill Of	Width (m)	Depth (m)	Description	Finds	Date		
13200	Layer		2.1	0.34	Ploughsoil. Dark brownish grey sandy silt, friable with rounded stones and gravel				
13201	Layer		2.1	0.2	Colluvial Layer. Mid yellowish brown sandy silt friable	Struck Flint			
13202	Layer		2.1		Natural. Mid reddish brown with light yellow patches, clay with silty patches. Brick Earth.				
13203	Layer				Natural. Light olive sandy silt. Weekly stratified Brick Earth				
13204	Layer				Colluvial Layer. Light brownish grey silty sand in the natural in the northern part of the trench. Colluvium				
13205	Layer			0.92	Natural. Light olive slightly clayey sandy silt with rare fine white lenses. SLOPE DEPOSIT in augerhole AH1320				
13206	Layer			0.09	Natural. Light brownish grey sand, iron pan at base. SAND DEPOSIT Augerhole AH1330				
13207	Layer			0.18	Natural. Brown clayey silt. SLOPE DEPOSIT in augerhole AH1320				
13208	Layer			0.9	Natural. Light brown slightly sandy silt SLOPE DEPOSIT in augerhole AH1320				
13209	Layer			0.3	Natural. Yellowish brown poorly sorted gravelly sand. PLEISTOCENE GRAVELLY SAND in augerhole AH1320				
13210	Layer			0.52	Natural. Brown stratified sandy gravelly silt. HEAD DEPOSIT in augerhole AH1321				
Trench 133									
General description						Orientation		E-W	
Trench devoid of archaeology. Ploughsoil overlays a gravelly natural						Length (m)		30	
						Width (m)		2.1	
						Avg. depth (m)		0.35	

Context No.	Type	Fill Of	Width (m)	Depth (m)	Description	Finds	Date
13300	Layer			0.35	Ploughsoil. Grey brown sandy silt		
13301	Layer				Natural. Sandy gravels		
Trench 134							
General description					Orientation		N-S
Trench devoid of archaeology. Excavated to a depth of 2m revealing ploughsoil and colluvium overlying Pleistocene deposits.					Length (m)		30
					Width (m)		2.1
					Avg. depth (m)		2
Context No.	Type	Fill Of	Width (m)	Depth (m)	Description	Finds	Date
13400	Layer		2.1	0.4	Ploughsoil. Mid grey brown silty sand, friable with rounded stone and rooting inclusions		
13401	Layer			0.8	Colluvial Layer		
13402	Layer			0.17	Colluvial Layer. Pale yellow mottled sand. SANDY COLLUVIUM		
13403	Layer			0.3	Natural. Strong brown silty clay with pale yellow sand lenses. Possible Bt horizon. SLOPE DEPOSIT		
13404	Layer			0.25	Natural. Reddish brown clayey slightly sandy silt, rare sand lenses. DECALCIFIED BRICK EARTH/SLOPE DEPOSIT		
13405	Layer		1.29		Natural. Light olive brown silty sand, few fine white silt lenses. BRICK EARTH/SLOPE DEPOSIT in augerhole AH1340		
13406	Layer				Natural. Light brown slightly silty and clayey sand. SLOPE DEPOSIT in AH1340		
13407	Layer			0.06	Natural. Light yellowish brown sand.		
13408	Layer			1.29	Natural. Light brown slightly clayey and sandy silt SLOPE DEPOSIT in AH1340		
13409	Layer			0.15	Natural. Light brown silt loam with abundant flint pebbles. HEAD DEPOSIT in AH1340		
13410	Layer				Natural		
Trench 135							
General description					Orientation		N-S
consists of ploughsoil and subsoil overlaying a silty clay natural					Length (m)		30
					Width (m)		2.1
					Avg. depth (m)		0.8
Context No.	Type	Fill Of	Width (m)	Depth (m)	Description	Finds	Date
13500	Layer		2.1	0.36	Ploughsoil. Mid greyish brown, sandy silt		
13501	Layer		2.1	0.24	Subsoil. mid orangish brown, friable, sandy silt		
13502	Layer		2.1	0.19	Natural. Mid orangish brown silty clay		
13503	Cut				Natural Feature. mid orangish brown silty clay		
13504	Layer			0.1	Colluvial Layer. Yellow brown silty sand.		



13505	Layer			0.26	Natural. Brickearth. Red brown sandy clay silt.		
13506	Layer			0.44	Natural. Decalcified brickearth. Red brown sandy clay silt.		
13507	Layer			22	Natural. Brickearth/slope deposit (decalcified). Yellow brown clay silt.		
13508	Layer			1.68	Natural. Slope deposit/brickearth. Light olive silty sand. AH 1350		
13509	Layer			0.18	Natural. Slope deposit. Brown yellow silty sand. AH1350		
13510	Layer			0.16	Natural. Slope deposit. Blight brown yellow sandy silt. AH1350		
13511	Layer			0.4	Natural. Head deposit. Brown clayey sandy silt with angular FLINT. AH1350		
13512	Layer			0.06	Natural. Possible river terrace gravel. Silty sand with gravel. (Pleistocene deposit). AH1350		

#### Trench 136

General description					Orientation		NW-SE
Trench devoid of archaeology. Consists of ploughsoil and colluvium overlying natural geology of silty sand and gravel.					Length (m)		30
					Width (m)		2.3
					Avg. depth (m)		0.55

Context No.	Type	Fill Of	Width (m)	Depth (m)	Description	Finds	Date
13600	Layer			0.35	Ploughsoil. Dark grey sandy silt.		
13601	Layer			0.4	Colluvial Layer. Light brown sandy silt		
13602	Layer				Natural. Gravel and orange sand in the NW part of the trench, and light brown silty sand in the SE part.		

#### Trench 137

General description					Orientation		E-W
Trench devoid of archaeology. Excavated to a depth of 2m at the eastern end. Consists of ploughsoil, subsoil and colluvium overlying natural geology of silty sand.					Length (m)		30
					Width (m)		2.3
					Avg. depth (m)		1

Context No.	Type	Fill Of	Width (m)	Depth (m)	Description	Finds	Date
13700	Layer			0.25	Ploughsoil. Dark greyish brown sandy silt.	Struck Flint	
13701	Layer			0.2	Subsoil. Light greyish brown silty sand.		
13702	Layer			0.55	Colluvial Layer. Light brown sandy silt.		
13703	Layer				Colluvial Layer. Mottled fine light greyish yellow sandy silt.	Struck Flint	
13704	Layer			0.26	Colluvial Layer. Yellowish brown sandy silt with pebbles		
13705	Layer			0.35	Colluvial Layer. Light greyish brown sandy silt, few pebbles		
13706	Layer			0.2	Colluvial Layer. Pale brownish yellow silt with frequent small black mottles		
13707	Layer			0.24	Natural. Yellowish brown clayey silt with black mottling. SLOPE DEPOSIT		
13708	Layer			0.26	Natural. Brown slightly clayey silt with frequent black mottling. SLOPE DEPOSIT		

13709	Layer			0.8	Natural. Light olive brown silt. SLOPE DEPOSIT		
13710	Layer			0.7	Natural. Pale brown slightly clayey sandy silt. SLOPE DEPOSIT		
13711	Layer			0.2	Natural. Yellowish brown clayey silty sand		
13712	Layer			0.15	Natural. Light brown poorly sorted gravelly Sand		
13713	Layer			0.15	Natural. Dark greenish grey silty sand.		

#### Trench 138

General description						Orientation		N-S
Trench excavated to a depth of 2m, revealing ploughsoil overlying colluvial layers.						Length (m)		30
						Width (m)		2.1
						Avg. depth (m)		2

Context No.	Type	Fill Of	Width (m)	Depth (m)	Description	Finds	Date
13800	Layer			0.28	Ploughsoil. Dark grey mod compact sandy silt		
13801	Layer			0.39	Colluvial Layer. Light greyish brown with orangey mottling sandy silt		
13802	Layer			0.4	Natural. Dark orangey brown silty clay		
13803	Layer			0.48	Colluvial Layer. Brownish grey slightly clayey silt. SLOPE DEPOSIT/VALLEY FILL	Struck Flint	
13804	Layer			0.23	Colluvial Layer. Light yellow slightly clayey and sandy silt, few Mg concretions. SLOPE DEPOSIT/VALLEY FILL		
13805	Layer			0.22	Natural. brownish yellow clayey silt, common Mg concretions.		

#### Trench 139

General description						Orientation		E-W
Trench devoid of archaeology. Consists of ploughsoil and subsoil overlaying a silty natural						Length (m)		30
						Width (m)		2.1
						Avg. depth (m)		0.5

Context No.	Type	Fill Of	Width (m)	Depth (m)	Description	Finds	Date
13900	Layer		2.1	0.4	Ploughsoil. Mid grey brown silty sand, friable with rounded stone and rooting inclusions		
13901	Layer		2.1	0.16	Subsoil. Mid yellowish brown silty sand, friable		
13902	Layer		2.1		Natural. Mid yellowish orangey brown, silty sand rich in manganese		

#### Trench 140

General description						Orientation		N-S
Trench devoid of archaeology. Consists of ploughsoil and subsoil overlying natural geology of sandy silt.						Length (m)		30
						Width (m)		2.3
						Avg. depth (m)		0.6

Context No.	Type	Fill Of	Width (m)	Depth (m)	Description	Finds	Date
-------------	------	---------	-----------	-----------	-------------	-------	------

14000	Layer			0.35	Ploughsoil. Dark brown sandy silt.	Flint	
14001	Layer			0.12	Subsoil. Light greyish brown sandy silt.		
14002	Layer			0.27	Colluvial Layer. Light yellowish orange sandy silt.		
14003	Layer				Natural. Light orangey brown		
14004	Cut		1.7	0.7	Ditch. E-W running ditch containing prehistoric pottery and flint in its upper fill.		
14005	Fill	14004	0.2	0.4	Primary Fill. Mid yellow brown clay silt with moderate manganese. Below (14007).		
14006	Fill	14004	0.4	0.06	Primary Fill. Light yellow grey silty sand with clay lenses.		
14007	Fill	14004	1.4	0.05	Secondary Fill. Light yellow grey sandy silt and frequent charcoal. Below (14008).		
14008	Fill	14004	1.1	0.3	Secondary Fill. Light blue grey sandy silt.		
14009	Fill	14004	0.55	0.05	Primary Fill. Mid yellow brown clay silt. Likely a minor collapse of the sides.		
14010	Fill	14004	1.5	0.34	Secondary Fill. Light grey blue sandy silt, perhaps alluvial in nature? Contains flint and pottery.	Pot, Struck Flint	AD270- 400
14011	Cut		0.66	0.5	Ditch. Truncated by ditch 14004.		
14012	Fill	14011	0.25	0.66	Primary Fill. Light yellow grey sandy silt. Likely resulting from collapse of sides. Below 14013.		
14013	Fill	14011	0.46	0.32	Secondary Fill. Mid yellow brown clay silt with manganese. Below 14013.		
14014	Fill	14011	0.44	0.12	Secondary Fill. Mid brown grey sandy silt. Uppermost fill of ditch 14011		
14015	Layer			0.76	Other Layer. Yellowish brown to brown clayey silt, abundant Mg/Fe mottling Brickearth?		
14016	Layer			0.45	Other Layer. Mid reddish brown clay silt.		
14017	Layer			0.17	Other Layer. Grey silt mottled reddish brown. SLOPE DEPOSIT / COLLUVIUM ?	Struck Flint	
14018	Layer			0.21	Colluvial Layer. Pale brownish grey diffusely mottled clayey sandy silt. SLOPE DEPOSIT / COLLUVIUM		
14019	Layer		2.3	0.05	Other Layer. Layer of pebbles and worked flint. Section collapsed before recording could take place.	Struck Flint	

#### Trench 141

General description		Orientation	NE-SW
Trench devoid of archaeology. Consists of ploughsoil and subsoil overlying natural geology of sandy silt.		Length (m)	30
		Width (m)	2.3
		Avg. depth (m)	0.65

Context No.	Type	Fill Of	Width (m)	Depth (m)	Description	Findings	Date
14100	Layer			0.35	Ploughsoil. Mid brown sandy silt.		
14101	Layer			0.25	Colluvial Layer. Light greyish brown sandy silt.		
14102	Layer				Natural. Light greyish yellow sandy silt.	Struck Flint	
14103	Cut		4.3		Ditch or palaeochannel.		

14104	Fill	14103	4.3	1	Primary Fill. Light yellow grey silty sand. Initial deposit slumping into paleo channel. Env samples S.25 & S.26.	Struck Flint	Later Bronze Age?
14105	Fill	14103	0.8	0.2	Other Fill. Mid brown yellow manganese rich silty sand.		
14106	Fill	14103	3.8	0.4	Other Fill. Light brown yellow silty sand. Abundant manganese		
14107	Fill	14103	3.1	0.4	Other Fill. Light yellow grey silty sand		
14108	Fill	14103	2.9	0.4	Other Fill. Mid yellow grey silty sand. Uppermost fill of feature.	Struck Flint	
14109	Layer			0.2	Colluvial Layer. Light yellow grey silty sand.		
14110	Layer			0.3	Other Layer. Laminated bands of light grey yellow sandy silt and mid yellow brown silty clay.		
14111	Layer				Other Layer. Brickearth. Mid red brown silty clay.	Struck Flint	
14112	Layer				Natural. Pale brownish grey silt. Natural bleached Slope Deposit	Struck Flint	
14113	Layer			0.2	Natural. Strong brown clayey silt, stone free SLOPE DEPOSIT in augerhole AH1410		
14114	Layer			0.15	Natural. Light brown fine to medium sand. SAND DEPOSIT in augerhole AH1410		
14115	Layer			0.8	Natural. Stiff grey silty clay. POSSIBLE BEDROCK		

Trench 142

General description	Orientation	NW-SE
Trench revealed two ditches. Consists of ploughsoil and a thin subsoil overlying natural	Length (m)	30
	Width (m)	2.1
	Avg. depth (m)	0.47

Context No.	Type	Fill Of	Width (m)	Depth (m)	Description	Finds	Date
14200	Layer			0.3	Ploughsoil. Dark grey brown sandy silt.		
14201	Layer			0.1	Subsoil. light grey brown sandy silt.		
14202	Layer				Natural. Light brown sandy gravel		
14203	Cut		0.9	0.24	Ditch		
14204	Fill	14203	0.9	0.24	Primary Fill. Mid grey brown silty clay.		
14205	Cut		0.59	0.15	Ditch		
14206	Fill	14205	0.59	0.15	Primary Fill. Mid grey brown silty clay.		

Trench 143

General description	Orientation	N-S
Trench devoid of archaeology. Ploughsoil overlays natural	Length (m)	30
	Width (m)	2.1
	Avg. depth (m)	0.37

Context No.	Type	Fill Of	Width (m)	Depth (m)	Description	Finds	Date
14300	Layer			0.3	Ploughsoil. Mid grey brown sandy silt.		
14301	Layer				Natural. sandy gravels		

Trench 144							
General description					Orientation		N-S
Trench revealed two ditches. Consists of ploughsoil and a thin subsoil overlaying natural					Length (m)		30
					Width (m)		2.1
					Avg. depth (m)		0.37
Context No.	Type	Fill Of	Width (m)	Depth (m)	Description	Finds	Date
14400	Layer		2.1	0.28	Ploughsoil. mid greyish brown sandy silt		
14401	Layer		2.1	0.06	Subsoil. light greyish brown sandy silt, depth varies a lot across trench		
14402	Layer		2.1	0.1	Natural. Mid orangish brown, sandy silt gravel		
14403	Cut		1.2	0.38	Ditch. Linear ditch, continues into 145, aligns with crop marks		
14404	Fill	14403	1.2	0.38	Secondary Fill. Dark greyish brown sandy silt		
14405	Unexcavated feature		2.7		Ditch. Linear running E-W, dark orangish brown sandy silt		
Trench 145							
General description					Orientation		N-S
Consists of ploughsoil overlaying gravelled natural					Length (m)		30
					Width (m)		2.1
					Avg. depth (m)		0.3
Context No.	Type	Fill Of	Width (m)	Depth (m)	Description	Finds	Date
14500	Layer			0.48	Ploughsoil. Dark grey mod compact sandy silt		
14501	Layer				Natural. Orange gravelly sand		
14502	Cut		3.03	0.56	Ditch. E/W. Not bottomed		
14503	Fill	14502		0.3	Primary Fill. Dark brownish grey sandy mod compact silt. Very organic		
14504	Fill	14502		0.28	Secondary Fill. Light brownish grey sandy silt	CBM	C19th
14505	Cut		2.7		Ditch. Unexcavated. Light brownish grey sandy silt		
14506	Cut		0.84		Modern. Cut of sheep burial.		
Trench 146							
General description					Orientation		N-S
Trench devoid of archaeology. Consists of ploughsoil and subsoil overlying silty sand natural with patches of gravel.					Length (m)		30
					Width (m)		2.3
					Avg. depth (m)		0.8
Context No.	Type	Fill Of	Width (m)	Depth (m)	Description	Finds	Date
14600	Layer		2.3	0.3	Ploughsoil. Dark grey brown sandy silt		
14601	Layer		2.3	0.48	Colluvial Layer. Mid yellowish brown silty sand later with occasional CBM and sub-angular stones.		
14602	Layer		2.3		Natural. Mid brownish orange silty sand with patches of gravel.		

Trench 147								
General description						Orientation		NW-SE
Trench revealed two ditches. Consists of ploughsoil and subsoil overlying silty sand with patches of gravel.						Length (m)		30
						Width (m)		2.3
						Avg. depth (m)		0.63
Context No.	Type	Fill Of	Width (m)	Depth (m)	Description	Finds	Date	
14700	Layer		2.3	0.4	Topsoil. Plough soil			
14701	Layer		2.3	0.2	Colluvial Layer. Mid yellowish brown silty sand with occasional CBM and sub-angular stones.			
14702	Layer		2.3	0.03	Natural. Mid brownish orange silty sand with patches of gravel.			
14703	Cut		0.6	0.22	Ditch. Linear running WNW-ESE across NNW end of trench			
14704	Fill	14703	0.6	0.22	Secondary Fill. mid brownish orange sandy silt			
14705	Cut	14705	1.07		Shallow ditch with single fill of brownish orange sandy silt.			
14706	Unexcavated feature		1.2		Ditch. Linear running WNW-ESE at SSE end of trench modern, brick surface finds.	CBM	C16-18th	

Trench 148								
General description						Orientation		N-S
Trench devoid of archaeology. Consists of ploughsoil overlaying natural						Length (m)		30
						Width (m)		2.1
						Avg. depth (m)		0.38
Context No.	Type	Fill Of	Width (m)	Depth (m)	Description	Finds	Date	
14800	Layer			0.35	Ploughsoil. Dark grey brown sandy silt			
14801	Layer				Natural. Light brown sandy gravels			

Trench 149								
General description						Orientation		E-W
Trench devoid of archaeology. Consists of ploughsoil and subsoil overlying natural gravel.						Length (m)		30
						Width (m)		2.1
						Avg. depth (m)		0.5
Context No.	Type	Fill Of	Width (m)	Depth (m)	Description	Finds	Date	
14900	Layer		2.1		Ploughsoil. Mid grey brown silty sand, friable with rooting and rounded stone inclusions			
14901	Layer		2.1		Subsoil. Mid brownish orange, silty sand, friable			
14902	Layer		2.1		Colluvial Layer. Mid reddish orangey brown silt.			
14903	Layer				Natural. Mid brown sandy silt and gravel.			

Trench 150								
General description						Orientation		NW-SE
						Length (m)		30

Trench devoid of archaeology. Consists of ploughsoil and subsoil overlying natural geology of silty sand.						Width (m)	2.3
						Avg. depth (m)	0.9
Context No.	Type	Fill Of	Width (m)	Depth (m)	Description	Finds	Date
15000	Layer		2.3	0.4	Ploughsoil. Plough soil		
15001	Layer		2.3	0.4	Colluvial Layer. Mid brownish orange silty sand, no inclusions.		
15002	Layer		2.3		Natural. Mid brownish yellow silty sand with no inclusions.		
Trench 151							
General description						Orientation	W-E
Trench devoid of archaeology. Consisted of ploughsoil and subsoil overlying natural geology of silty sand.						Length (m)	20
						Width (m)	2.3
						Avg. depth (m)	0.6
Context No.	Type	Fill Of	Width (m)	Depth (m)	Description	Finds	Date
15100	Layer		2.3	0.3	Topsoil. Plough soil		
15101	Layer		2.3	0.3	Subsoil. Mid yellowish brown silty sand with no inclusions		
15102	Layer		2.3	0.35	Natural. Brownish orange silty sand with no inclusions		
Trench 152							
General description						Orientation	E-W
Consists of ploughsoil and subsoil overlaying natural sandy gravel.						Length (m)	30
						Width (m)	2.1
						Avg. depth (m)	0.8
Context No.	Type	Fill Of	Width (m)	Depth (m)	Description	Finds	Date
15200	Layer		2.1	0.24	Ploughsoil. dark greyish brown sandy silt		
15201	Layer		2.1	0.12	Subsoil. Mid brownish grey sandy silt		
15202	Layer		2.1	0.04	Natural. mid brownish orange sandy silty gravel		
15203	Cut		1.36	0.22	Ditch. Linear running NE-SW across the W end of the trench		
15204	Fill	15203	1.36	0.22	Secondary Fill. light greyish brown sandy silt		
15205	Layer		2.1	0.28	Natural. change in natural at E end of trench mid brownish orange, silty clay NO gravel		
Trench 153							
General description						Orientation	
Trench not excavated						Length (m)	
						Width (m)	
						Avg. depth (m)	
Context No.	Type	Fill Of	Width (m)	Depth (m)	Description	Finds	Date
Trench 154							

General description						Orientation		N-S
Trench devoid of archaeology. Consists of ploughsoil and subsoil overlying natural geology of gravels.						Length (m)		30
						Width (m)		2.3
						Avg. depth (m)		0.5
Context No.	Type	Fill Of	Width (m)	Depth (m)	Description	Finds	Date	
15400	Layer			0.35	Ploughsoil. Mid to dark grey brown sandy silt.			
15401	Layer			0.15	Subsoil. Mid brown silty sand.			
15402	Layer				Natural. Light brown sandy gravels			

#### Trench 155

General description						Orientation		E-W
Trench devoid of archaeology. Consisted of ploughsoil and remnants of made ground overlying natural geology of sandy gravels.						Length (m)		30
						Width (m)		2.3
						Avg. depth (m)		0.52
Context No.	Type	Fill Of	Width (m)	Depth (m)	Description	Finds	Date	
15500	Layer		2.3	0.5	Topsoil. Plough soil			
15501	Layer		0.3	0.19	Natural. light greyish brown, sandy clay			
15502	Cut		0.76	0.1	Pit. Small pit, one of 3 in trench			
15503	Fill	15502	0.76	0.1	Secondary Fill. Dark greyish brown fill silty clay. Charcoal recovered by hand.			
15504	Cut		0.42	0.5	Pit. small pit one of 3 in trench			
15505	Fill	15504	0.42	0.5	Secondary Fill. light greyish brown sandy clay, silty clay	FC	Modern	
15506	Cut		0.4	0.4	Pit. Small pit one of 3 in trench			
15507	Fill	15506	0.4	0.4	Secondary Fill. light greyish brown, silty clay			

#### Trench 156

General description						Orientation		N-S
Trench devoid of archaeology. Consists of ploughsoil overlying modern made ground. Excavated to a depth of 1m but the natural geology was no exposed.						Length (m)		30
						Width (m)		2.1
						Avg. depth (m)		1
Context No.	Type	Fill Of	Width (m)	Depth (m)	Description	Finds	Date	
15600	Layer		2.1	0.4	Ploughsoil. Mid grey brown silty sand, friable with rooting and rounded stone inclusions			
15601	Layer		2.1	0.16	Subsoil. Mid grey blue clay firm			
15602	Layer		2.1		Subsoil. Mid grey blue with mid orangey brown gravels, and mid yellowish white to the north, clay, firm			
15603	Cut		1.14	0.27	Modern. Modern cut. Contained plastic. Dark brown sandy clay.			
15604	Layer			0.8	Other Layer. Mixed of made ground layers identified across the trench and excavated to a depth of 1m without encountering the natural geology. Plastics identified at that depth at the bottom of the trench.			



Trench 157								
General description						Orientation		E-W
Trench devoid of archaeology. Consists of ploughsoil and made ground overlying natural geology of silty sand.						Length (m)		30
						Width (m)		2.1
						Avg. depth (m)		1
Context No.	Type	Fill Of	Width (m)	Depth (m)	Description	Finds	Date	
15700	Layer		2.1	0.6	Ploughsoil. Mid grey brown silty sand, friable with rooting and rounded stone inclusions			
15701	Layer		2.1	0.5	Other Layer. Made ground layer consisting of a mix of blueish, grey and brown clay. Similar to the made ground layers encountered in Trench 156.			
15702	Layer		2.1		Natural. Mid greyish brown silty sand.			
Trench 158								
General description						Orientation		E-W
Trench devoid of archaeology. Consists of ploughsoil and subsoil overlying natural geology of gravel.						Length (m)		30
						Width (m)		2.1
						Avg. depth (m)		0.3
Context No.	Type	Fill Of	Width (m)	Depth (m)	Description	Finds	Date	
15800	Layer		2.1	0.4	Ploughsoil. Mid grey brown silty sand, with rooting and rounded stone inclusions, friable			
15801	Layer		2.1	0.2	Subsoil. Mid yellowish brown silty sand, friable			
15802	Layer		2.1		Natural. Mid yellowish brown with mid brownish red silty sand, friable			
15803	Cut		0.7	0.13	Natural Feature. Mid orange brown. Sandy silt.			
Trench 159								
General description						Orientation		N-S
Trench devoid of archaeology. Consists of ploughsoil and subsoil overlying a silty clay natural.						Length (m)		30
						Width (m)		2.1
						Avg. depth (m)		0.5
Context No.	Type	Fill Of	Width (m)	Depth (m)	Description	Finds	Date	
15900	Layer		2.1	0.3	Ploughsoil. Mid grey brown, silty sand friable with rounded stones and rooting			
15901	Layer		2.1	0.2	Subsoil. Mid yellowish brown, silty sand, friable			
15902	Layer		2.1	0.14	Natural. light greyish brown, sandy clay			
15903	Cut				Natural Feature. Mid greyish brown sandy silt			
15904	Cut				Natural Feature. dark greyish brown sandy silt			
Trench 160								

General description						Orientation		E-W	
Trench devoid of archaeology. Consists of ploughsoil, made ground and subsoil overlying natural geology of silty sand.						Length (m)		30	
						Width (m)		2.1	
						Avg. depth (m)		0.8	
Context No.	Type	Fill Of	Width (m)	Depth (m)	Description	Finds	Date		
16000	Layer		2.1	0.1	Ploughsoil. Mid grey brown silty sand, friable with rounded stone inclusions				
16001	Layer		2.1	0.5	Other Layer. Possible dump/leveling deposit, mid blueish grey clay, firm				
16002	Layer		2.1	0.17	Subsoil. Mid yellowish orange, silty sand, friable with flecks of chalk throughout				
16003	Layer		2.1		Natural. Mid orangey reddish silty sand				
Trench 161									
General description						Orientation		N-S	
Trench devoid of archaeology. Consists of ploughsoil and subsoil overlying natural geology of silty sand and gravel.						Length (m)		30	
						Width (m)		2.1	
						Avg. depth (m)		0.6	
Context No.	Type	Fill Of	Width (m)	Depth (m)	Description	Finds	Date		
16100	Layer		2.1	0.4	Ploughsoil. Mid grey brown silty sand, friable with rooting and rounded stone inclusions				
16101	Layer		2.1	0.35	Subsoil. Mid grey brown silty sand with flint inclusions. Friable. One fragment of flint blade retrieved.	Flint			
16102	Layer				Natural. Light yellowish brown silty sand.				
Trench 162									
General description						Orientation		N-S	
Trench devoid of archaeology. Consists of ploughsoil overlying natural geology of silty sand and gravel.						Length (m)		30	
						Width (m)		2.1	
						Avg. depth (m)		0.3	
Context No.	Type	Fill Of	Width (m)	Depth (m)	Description	Finds	Date		
16200	Layer		2.1	0.2	Ploughsoil. Mid greyish brown				
16201	Layer		2.1	0.1	Natural. Mid reddish brown. Silty sand, with gravel stones				
16202	Cut		0.9	0.2	Natural Feature. Mid brown, gravel fill.				
16203	Cut		0.9	0.23	Natural Feature. Mid brown, loose gravel.				
Trench 163									
General description						Orientation		E-W	
Trench devoid of archaeology. Consists of ploughsoil and subsoil overlying a silty gravel natural.						Length (m)		30	
						Width (m)		2.1	
						Avg. depth (m)		0.4	
Context No.	Type	Fill Of	Width (m)	Depth (m)	Description	Finds	Date		

16300	Layer		2.1	0.27	Topsoil. Mid greyish brown silty sand, friable with rooting and rounded stone inclusions		
16301	Layer		2.1	0.16	Subsoil. Mid orangey brown silty sand, friable		
16302	Layer		2.1		Natural. Mid reddish brown silty sand with gravel patches, firm		

#### Trench 164

General description					Orientation		N-S
Trench devoid of archaeology. Consisted of ploughsoil and subsoil overlay a silty sand natural.					Length (m)		30
					Width (m)		2.1
					Avg. depth (m)		0.6

Context No.	Type	Fill Of	Width (m)	Depth (m)	Description	Finds	Date
16400	Layer		2.1	0.3	Topsoil. Mod grey brown silty sand, friable with rooting and rounded stone inclusions		
16401	Layer		2.1	0.2	Subsoil. Mid yellow brown silty sand, friable		
16402	Layer		2.1		Natural. Mid orangey yellowish brown, silty sand, friable		

#### Trench 165

General description					Orientation		E-W
Trench devoid of archaeology. Consists of ploughsoil and subsoil overlying a silt sand natural.					Length (m)		30
					Width (m)		2.1
					Avg. depth (m)		0.5

Context No.	Type	Fill Of	Width (m)	Depth (m)	Description	Finds	Date
16500	Layer		2.1	0.3	Ploughsoil. Mid grey brown, silty sand, friable with rooting and rounded stone inclusions		
16501	Layer		2.1	0.19	Subsoil. Mid orange brown silty sand, friable		
16502	Layer		2.1		Natural. Mid orangey reddish brown silty sand with gravel patches friable		

#### Trench 166

General description					Orientation		N-S
Trench devoid of archaeology. Consists of ploughsoil and subsoil overlaying a silty sand natural.					Length (m)		30
					Width (m)		2.1
					Avg. depth (m)		0.5

Context No.	Type	Fill Of	Width (m)	Depth (m)	Description	Finds	Date
16600	Layer		2.2	0.4	Ploughsoil. Mid grey brown silty sand, friable with rounded stone inclusions		
16601	Layer		2.1	0.1	Subsoil. Mid orangey brown silty sand, friable		
16602	Layer		2.1		Natural. Mid reddish brown silty sand, firm		

#### Trench 167

General description					Orientation		E-W
---------------------	--	--	--	--	-------------	--	-----

Trench devoid of archaeology. Consists of ploughsoil and subsoil overlaying natural geology of silty sand and gravel.						Length (m)		30
						Width (m)		2.1
						Avg. depth (m)		0.7
Context No.	Type	Fill Of	Width (m)	Depth (m)	Description	Finds	Date	
16700	Layer		2.1	0.4	Ploughsoil. Mid grey brown silty sand, friable with rounded stone inclusions			
16701	Layer		2.1	0.3	Subsoil. Mid orangey brown silty sand, friable			
16702	Layer		2.1		Natural. Mid reddish brown with mid yellowish white patches, friable			
Trench 168								
General description						Orientation		E-W
Trench revealed two pits. Consists of ploughsoil overlaying natural geology of gravel.						Length (m)		30
						Width (m)		2.1
						Avg. depth (m)		0.4
Context No.	Type	Fill Of	Width (m)	Depth (m)	Description	Finds	Date	
16800	Layer		2.1	0.4	Ploughsoil. Mid grey brown, silty sand, friable with rounded stone inclusions and rooting			
16801	Layer		2.1		Natural. Mid yellowish orange, silty sand, with gravel patches. Loose			
16802	Cut		1.6	0.6	Pit			
16803	Fill	16802	1.6	0.6	Secondary Fill. Mid brownish grey. Silty sand, loose gravel stones	Pot	c 1140-1220	
16804	Cut		0.6	0.3	Pit			
16805	Fill	16804	0.6	0.3	Secondary Fill. Mid brownish grey. Silty sand, loose gravel stones			
16806	Cut		0.6	0.16	Natural Feature. Mid brownish grey. Silty sand, loose gravel stones			
Trench 169								
General description						Orientation		NE-SW
Trench devoid of archaeology. Consists of ploughsoil overlaying silty gravel natural.						Length (m)		30
						Width (m)		2.1
						Avg. depth (m)		0.3
Context No.	Type	Fill Of	Width (m)	Depth (m)	Description	Finds	Date	
16900	Layer		2.1	0.4	Ploughsoil. mid grayish brown, friable, silt			
16901	Layer		2.1	0.19	Natural. mid orangish brown silty gravel			
16902	Cut				Natural Feature. Light grayish brown silty sand and gravel			
Trench 170								
General description						Orientation		E-W
Trench devoid of archaeology. Consists of ploughsoil and subsoil overlaying natural geology of silty sand and gravel.						Length (m)		30
						Width (m)		2.1
						Avg. depth (m)		0.6

Context No.	Type	Fill Of	Width (m)	Depth (m)	Description	Finds	Date
17000	Layer		2.1	0.4	Ploughsoil. Mid grey brown silty sand, with rooting and rounded stone inclusions		
17001	Layer		2.1	0.2	Subsoil. Mid yellowish brown silty sand, friable with occasional pebble inclusions		
17002	Layer		2.1		Natural. Mid yellowish brown with mid reddish brown throughout, clay with silty patches, firm		

#### Trench 171

General description					Orientation		NE-SW
Trench revealed a ditch. Consists of ploughsoil overlaying natural geology of gravel.					Length (m)		30
					Width (m)		2.1
					Avg. depth (m)		0.39

Context No.	Type	Fill Of	Width (m)	Depth (m)	Description	Finds	Date
17100	Layer		2.1	0.32	Ploughsoil. Mid grey brown silty sand, friable with rooting and rounded stone inclusions		
17101	Layer		2.1		Natural. Mid reddish yellow, silty sand with gravel inclusions, firm		
17102	Cut				Ditch.		
17103	Fill				Secondary Fill. dark greyish brown silty sand, frequent stone and flint inclusions		
17104	Cut				Natural Feature. mid greyish brown sandy silt		
17105	Cut				Natural Feature. mid greyish brown sandy silt, some modern inclusions		

#### Trench 172

General description					Orientation		E-W
Trench devoid of archaeology. Consists of ploughsoil and subsoil overlay natural geology of silty sand and gravel.					Length (m)		30
					Width (m)		2.1
					Avg. depth (m)		0.4

Context No.	Type	Fill Of	Width (m)	Depth (m)	Description	Finds	Date
17200	Layer		2.1	0.3	Ploughsoil. Mid grey brown silty sand, friable with tooting and rounded stone inclusions		
17201	Layer		2.1	0.3	Subsoil. Mid yellowish brown silty sand with occasional fragmented flint inclusion		
17202	Layer		2.1		Natural. Mid reddish brown, silty sandy gravels and silty sandy clay, firm		

#### Trench 173

General description					Orientation		NW-SE
Trench devoid of archaeology. Consists of ploughsoil and subsoil overlaying natural geology of silty sand and gravel.					Length (m)		30
					Width (m)		2.1
					Avg. depth (m)		0.5

Context No.	Type	Fill Of	Width (m)	Depth (m)	Description	Finds	Date
-------------	------	---------	-----------	-----------	-------------	-------	------

17300	Layer		2.1	0.25	Ploughsoil. Mid greyish brown silty sand, friable with rounded stone and rooting inclusions		
17301	Layer		2.1	0.25	Subsoil. Mid reddish brown silty sand, friable with gravel inclusions		
17302	Layer		2.1		Natural. Mid reddish brown silty clay, firm with rounded stones and flint inclusions		
17303	Cut				Natural Feature. Mid reddish brown silty clay		

#### Trench 174

General description					Orientation		NE-SW
Trench devoid of archaeology. Consists of ploughsoil overlaying natural geology of silty sand and gravel.					Length (m)		30
					Width (m)		2.3
					Avg. depth (m)		0.73

Context No.	Type	Fill Of	Width (m)	Depth (m)	Description	Finds	Date
17400	Layer		2.3	0.3	Ploughsoil		
17401	Layer		2.3	0.4	Colluvial Layer. Mid reddish brown silty clay with patches of gravel		
17402	Layer		2.3	0.2	Natural. Reddish orange silty clay with patches of mid yellowish brown silty sand.		

#### Trench 175

General description					Orientation		NW-SE
Trench revealed a pit at the northern end. Consisted of ploughsoil overlaying silty sand natural.					Length (m)		30
					Width (m)		2.3
					Avg. depth (m)		0.5

Context No.	Type	Fill Of	Width (m)	Depth (m)	Description	Finds	Date
17500	Layer		2.3	0.3	Ploughsoil. Mid brown grey		
17501	Layer		2.3	0.1	Natural. Mid reddish brown. Silty sand with gravel inclusion.		
17502	Cut		1.6	0.42	Pit. 4.0m long, 1.6m wide, oriented NNW-SSE		
17503	Fill	17502	1.6	0.42	Secondary Fill. Mid brown grey, soft silty sand, gravel inclusion		

#### Trench 176

General description					Orientation		E-W
Trench devoid of archaeology. Consisted of ploughsoil overlaying natural gravel.					Length (m)		30
					Width (m)		2.1
					Avg. depth (m)		0.35

Context No.	Type	Fill Of	Width (m)	Depth (m)	Description	Finds	Date
17600	Layer			0.35	Ploughsoil. Grey brown sandy silt.		
17601	Layer				Natural. Sandy gravels		

#### Trench 177

General description					Orientation		N-S
					Length (m)		30

Trench devoid of archaeology. Consisted of ploughsoil and subsoil overlying natural geology of clay and gravel.					Width (m)	2.3	
					Avg. depth (m)	0.5	
Context No.	Type	Fill Of	Width (m)	Depth (m)	Description	Finds	Date
17700	Layer		2.3	0.26	Ploughsoil. Dark grey brown sandy silt		
17701	Layer		2.3	0.25	Subsoil. Mid reddish brown silty clay with patches of gravel		
17702	Layer		2.3	0.2	Natural. Mid yellowish brown silty clay at Northern end, reddish orange silty clay with patches of gravel at Southern end.		

#### Trench 178

General description					Orientation	E-W	
Trench devoid of archaeology. Consisted of ploughsoil and subsoil overlying natural geology of clay and gravel.					Length (m)	30	
					Width (m)	2.3	
					Avg. depth (m)	0.55	
Context No.	Type	Fill Of	Width (m)	Depth (m)	Description	Finds	Date
17800	Layer		2.3	0.35	Ploughsoil		
17801	Layer		2.3	0.2	Subsoil. Reddish brown silty clay.		
17802	Layer		2.3	0.15	Natural. Mid reddish orange silty clay with patches of gravel.		

#### Trench 179

General description					Orientation	N-S	
Trench devoid of archaeology. Consisted of ploughsoil and subsoil overlying natural geology of sandy gravel.					Length (m)	30	
					Width (m)	2.1	
					Avg. depth (m)	0.42	
Context No.	Type	Fill Of	Width (m)	Depth (m)	Description	Finds	Date
17900	Layer			0.3	Ploughsoil. Mid to dark grey brown sandy silt.		
17901	Layer			0.12	Subsoil. Mid brown sandy clay.		
17902	Layer				Natural. Mid reddish brown sandy clay gravels.		

#### Trench 180

General description					Orientation	E-W	
Trench devoid of archaeology. Consists of ploughsoil overlaying natural geology of sand and gravel.					Length (m)	30	
					Width (m)	2.1	
					Avg. depth (m)	0.45	
Context No.	Type	Fill Of	Width (m)	Depth (m)	Description	Finds	Date
18000	Layer		2.1	0.42	Ploughsoil. Mid greyish brown, rooting with rounded stones silty sand, friable		
18001	Layer				Natural. Mid reddish brown, silty clay with flint gravelly patches, firm		

#### Trench 181

General description					Orientation	N-S
---------------------	--	--	--	--	-------------	-----

Trench devoid of archeology,. Consisted of ploughsoil overlaying natural geology of sand and gravel.						Length (m)		30
						Width (m)		2.3
						Avg. depth (m)		0.79
Context No.	Type	Fill Of	Width (m)	Depth (m)	Description	Finds	Date	
18100	Layer		2.3	0.3	Ploughsoil. Dark grey brown sandy silt.			
18101	Layer		2.3	0.47	Colluvial Layer. Mid reddish brown silty clay with fragmented flint and rounded stone inclusions			
18102	Layer				Natural. Yellow silty sand with patches of reddish brown clay			

#### Trench 182

General description						Orientation		NE-SW
Trench revealed a ditch. Consists of ploughsoil and subsoil overlaying natural geology of sandy gravel.						Length (m)		30
						Width (m)		2.1
						Avg. depth (m)		0.4
Context No.	Type	Fill Of	Width (m)	Depth (m)	Description	Finds	Date	
18200	Layer		2	0.27	Ploughsoil. Dark grey sandy silt			
18201	Layer		2	0.08	Subsoil. Dark brownish grey sandy silt			
18202	Layer		2		Natural. Mid orangey brown sandy clay	CBM	C16-18th	
18203	Cut		0.97	0.29	Ditch. E/W			
18204	Fill	18203	0.97	0.29	Secondary Fill. Light grey mod compact sandy silt.	Pot, Cu Alloy, CBM, oyster shell	Pot c 1525-1550/75, CBM C16th & C18th	
18205	Cut		0.92	0.08	Natural Feature. Light grey sandy silt			
18206	Layer		2	0.4	Unexcavated. Light greyish brown sandy silt. Much CBM present, possible quarrying backfill.			

#### Trench 183

General description						Orientation		E-W
Trench revealed two large pits. Consists of ploughsoil and subsoil overlaying natural gravel.						Length (m)		30
						Width (m)		2.1
						Avg. depth (m)		0.6
Context No.	Type	Fill Of	Width (m)	Depth (m)	Description	Finds	Date	
18300	Layer		2.1	0.3	Ploughsoil. Mid grey brown, silty sand, friable with rooting and rounded stone inclusions			
18301	Layer			0.25	Subsoil. Mid reddish brown silty clay, with fragmented flint and rounded stone inclusions			
18302	Layer		2.1	0.05	Natural. Orange yellow, sandy silt gravel like inclusions			
18303	Cut		1.8	0.4	Pit			
18304	Fill	18303	1.8	0.1	Primary Fill. Mid brown reddish, collapse of sides?			



18305	Fill	18303	1.8	0.3	Secondary Fill. Mid brown grey, stone inclusions.	Pot, CBM	c 1480-1550
18306	Unexcavated feature		8		Pit. Mid brown grey fill, could be a quarry pit?		
Trench 184							
General description					Orientation		E-W
Trench devoid of archaeology. Consists of ploughsoil overlaying silty clay natural.					Length (m)		30
					Width (m)		2.1
					Avg. depth (m)		0.42
Context No.	Type	Fill Of	Width (m)	Depth (m)	Description	Finds	Date
18400	Layer			0.3	Ploughsoil. Mid grey brown sandy silt.		
18401	Layer				Natural. sandy clay natural		
Trench 185							
General description					Orientation		NW-SE
Trench revealed one ditch. Consists of ploughsoil overlaying natural gravel.					Length (m)		30
					Width (m)		2.1
					Avg. depth (m)		0.4
Context No.	Type	Fill Of	Width (m)	Depth (m)	Description	Finds	Date
18500	Layer		2.1	0.4	Ploughsoil. mid greyish brown, friable silty clay		
18501	Layer		2.1	0.03	Natural. Mid reddish brown silty clay		
18502	Cut				Natural Feature. Mid reddish brown silty clay		
18503	Unexcavated feature		2.5		Ditch. Linear ditch at NE end running N-S also present in 183		
Trench 186							
General description					Orientation		NE-SW
Trench devoid of archaeology. Consisted of ploughsoil overlaying natural gravel.					Length (m)		30
					Width (m)		2.2
					Avg. depth (m)		48
Context No.	Type	Fill Of	Width (m)	Depth (m)	Description	Finds	Date
18600	Layer		2.3	0.35	Ploughsoil. Dark grey brown sandy silt		
18601	Layer				Natural. Reddish orange clay with patches of yellow brown sandy clay and bands of gravel		
Trench 187							
General description					Orientation		
Trench not excavated					Length (m)		
					Width (m)		
					Avg. depth (m)		
Context No.	Type	Fill Of	Width (m)	Depth (m)	Description	Finds	Date

Trench 188								
General description						Orientation		
Trench not excavated						Length (m)		
						Width (m)		
						Avg. depth (m)		
Context No.	Type	Fill Of	Width (m)	Depth (m)	Description	Finds	Date	
Trench 189								
General description						Orientation		
Trench not excavated						Length (m)		
						Width (m)		
						Avg. depth (m)		
Context No.	Type	Fill Of	Width (m)	Depth (m)	Description	Finds	Date	
Trench 190								
General description						Orientation		NW-SE
Trench devoid of archaeology. Consists of ploughsoil and subsoil overlying natural geology of gravel.						Length (m)		30
						Width (m)		2.1
						Avg. depth (m)		0.86
Context No.	Type	Fill Of	Width (m)	Depth (m)	Description	Finds	Date	
19000	Layer		2.1	0.3	Ploughsoil. Mid grey silty sand with frequent pebbles and moderate flint			
19001	Layer		2.1	0.25	Subsoil. Light brown silty sand with occasional pebbles			
19002	Layer		2.1	0.3	Colluvial Layer. Mid red brown silty sand with occasional flint			
19003	Layer		2.1	0.01	Natural. Mid red brown gravelly silty sand with patches of Thanet sand			
Trench 191								
General description						Orientation		NE-SW
Trench devoid of archaeology. Consists of ploughsoil and subsoil overlying natural geology of sandy gravel.						Length (m)		30
						Width (m)		2.1
						Avg. depth (m)		0.76
Context No.	Type	Fill Of	Width (m)	Depth (m)	Description	Finds	Date	
19100	Layer		2.1	0.3	Ploughsoil. Mid grey silty sand with frequent pebbles and moderate flint			
19101	Layer		2.1	0.2	Subsoil. Light grey silty sand with occasional pebbles			
19102	Layer		2.1	0.25	Colluvial Layer. Mid red brown silty sand with occasional flint			
19103	Layer		2.1	0.01	Natural. Mid red brown gravelly silty sand			
Trench 192								
General description						Orientation		NE-SW
						Length (m)		30

Trench devoid of archaeology. Consists of ploughsoil and subsoil overlying natural geology of silty sand and gravel.						Width (m)	2.1
						Avg. depth (m)	0.5
Context No.	Type	Fill Of	Width (m)	Depth (m)	Description	Finds	Date
19200	Layer			0.3	Ploughsoil. Dark brown sandy silt.		
19201	Layer			0.2	Subsoil. Mid brown silty sand.		
19202	Layer				Natural		
19203	Cut				Natural Feature. Natural feature investigated.		
Trench 193							
General description						Orientation	NE-SW
Trench devoid of archaeology. Consists of ploughsoil, subsoil and colluvium overlying natural gravel.						Length (m)	30
						Width (m)	2.1
						Avg. depth (m)	0.86
Context No.	Type	Fill Of	Width (m)	Depth (m)	Description	Finds	Date
19300	Layer		2.1	0.3	Ploughsoil. Mid grey silty sand with frequent pebbles and moderate flint		
19301	Layer		2.1	0.25	Subsoil. Light brown silty sand with occasional pebbles		
19302	Layer		2.1	0.3	Alluvial Layer. Mid red brown clayey silt with occasional flint		
19303	Layer		2.1	0.01	Natural. Mid red brown gravelly silty sand		
19304	Cut		1.01	0.28	Natural Feature. Natural feature		
Trench 194							
General description						Orientation	E-W
Trench devoid of archaeology. Consists of ploughsoil and subsoil overlying natural gravel.						Length (m)	30
						Width (m)	2.1
						Avg. depth (m)	0.65
Context No.	Type	Fill Of	Width (m)	Depth (m)	Description	Finds	Date
19400	Layer		2.1	0.3	Ploughsoil. Mid grey silty sand with frequent pebbles and moderate flint		
19401	Layer		2.1	0.1	Subsoil. Light brown silty sand; moderate pebbles		
19402	Layer		2.1	0.15	Colluvial Layer. Mid red brown silty sand with occasional flint		
19403	Layer		2.1	0.05	Natural. Mid red brown gravelly silty sand		
Trench 195							
General description						Orientation	NE-SW
Trench devoid of archaeology. Consists of ploughsoil and subsoil overlying natural sandy gravel.						Length (m)	30
						Width (m)	2.1
						Avg. depth (m)	0.46
Context No.	Type	Fill Of	Width (m)	Depth (m)	Description	Finds	Date
19500	Layer		2.1	0.3	Ploughsoil. Mid grey silty sand with occasional flint and frequent pebbles		

19501	Layer		2.1	0.15	Subsoil. Light brown silty sand with occasional pebbles		
19502	Layer		2.1	0.01	Colluvial Layer. Mid red brown silty sand with occasional flint		
Trench 196							
General description					Orientation		E-W
Trench devoid of archaeology. Consists of ploughsoil and subsoil overlying natural sandy gravel.					Length (m)		30
					Width (m)		2.1
					Avg. depth (m)		0.7
Context No.	Type	Fill Of	Width (m)	Depth (m)	Description	Finds	Date
19600	Layer		2.1	0.35	Ploughsoil. Mid grey silty sand with occasional flint and frequent pebbles		
19601	Layer		2.1	0.25	Subsoil. Light brown silty sand with occasional pebbles		
19602	Layer		2.1	0.1	Colluvial Layer. Mid red brown silty sand with occasional flint		
Trench 197							
General description					Orientation		N-S
Trench devoid of archaeology. Consists of ploughsoil and subsoil overlying natural sandy gravel.					Length (m)		30
					Width (m)		2.1
					Avg. depth (m)		0.3
Context No.	Type	Fill Of	Width (m)	Depth (m)	Description	Finds	Date
19700	Layer			0.3	Ploughsoil. Dark greyish brown silt		
19701	Layer			0.7	Natural. Mid reddish brown silty clay, incredibly hard to base of deposit, and heavily broken and weathered to the top. Possible Pleistocene colluvium.		
19702	Layer				Natural. Chalky, calcareous sandy gravel below natural 19701		
Trench 198							
General description					Orientation		E-W
Trench devoid of archaeology. Consists of ploughsoil and subsoil overlying natural sandy gravel.					Length (m)		30
					Width (m)		2.1
					Avg. depth (m)		0.3
Context No.	Type	Fill Of	Width (m)	Depth (m)	Description	Finds	Date
19800	Layer		2.1	0.35	Ploughsoil. Grey silty sand with frequent pebbles and moderate flint		
19801	Layer		2.1	0.25	Subsoil. Light brown silty sand with occasional pebbles		
19802	Layer		2.1	0.3	Natural. Mid red brown silty sand with occasional flint. Possible Pleistocene colluvium		
19803	Layer		2.1	0.1	Natural. Mid red brown gravelly silty sand		
Trench 199							
General description					Orientation		NE-SW

Trench revealed a ditch and a pit. Consists of ploughsoil and subsoil overlying a sandy gravel natural.	Length (m)	30
	Width (m)	2.1
	Avg. depth (m)	0.65

Context No.	Type	Fill Of	Width (m)	Depth (m)	Description	Finds	Date
19900	Layer			0.39	Ploughsoil. Dark brownish grey clayey silt		
19901	Layer			0.16	Subsoil. Light grey clayey silt		
19902	Layer				Natural. Sandy gravel		
19903	Cut		0.94	0.32	Ditch. N/S		
19904	Fill	19903	0.94	0.32	Primary Fill. Soft light greyish brown silty sand		
19905	Cut		0.6	0.19	Pit		
19906	Fill	19905	0.6	0.19	Primary Fill. Soft light brownish grey silty sand		
19907	Cut		1.51	0.27	Tree Throw. Natural feature		
19908	Cut		1.75	0.27	Tree Throw. Natural feature		
19909	Cut		0.77	0.02	Pit. Natural feature		

#### Trench 200

General description					Orientation	N-S
Trench revealed one ditch. Consists of ploughsoil overlaying a sandy gravel natural.	Length (m)				30	
	Width (m)				2.1	
	Avg. depth (m)				0.6	

Context No.	Type	Fill Of	Width (m)	Depth (m)	Description	Finds	Date
20000	Layer		2.1	0.36	Ploughsoil. Mid brownish grey		
20001	Layer		2.1	0.3	Natural		
20002	Cut		0.64	0.15	Ditch. C/o linear ditch 1m slot, runs NE-SW		
20003	Fill	20002	0.64	0.15	Primary Fill. Reddish brown sandy silt		
20004	Cut		0.7	0.1	Natural Feature. C/o Natural feature		

#### Trench 201

General description					Orientation	E-W
Trench devoid of archaeology. Consists of ploughsoil overlaying natural geology of gravel and sand.	Length (m)				30	
	Width (m)				2.1	
	Avg. depth (m)				0.35	

Context No.	Type	Fill Of	Width (m)	Depth (m)	Description	Finds	Date
20100	Layer			0.35	Ploughsoil. Dark brownish grey silt with 5% <60mm rounded flint pebbles		
20101	Layer				Natural. Rounded flint gravel in mid orangey brown sand matrix		

#### Trench 202

General description					Orientation	N-S
Trench devoid of archaeology. Consists of ploughsoil and subsoil overlying natural sandy gravel.	Length (m)				30	
	Width (m)				2.1	

						Avg. depth (m)	0.65
Context No.	Type	Fill Of	Width (m)	Depth (m)	Description	Finds	Date
20200	Layer		2.1	0.35	Ploughsoil. Mid grey silty sand with diffused pebbles and moderate flint		
20201	Layer		2.1	0.15	Subsoil. Mid brown silty sand, moderate pebbles		
20202	Layer		2.1	0.1	Natural. Mid red brown silty sand. Rare pebbles.		
20203	Layer		2.1	0.05	Natural. Mid grey sandy gravel. Patches of mid red brown silty sand		

#### Trench 203

General description						Orientation	E-W
Trench devoid of archaeology. Consists of ploughsoil and subsoil overlying natural sandy gravel.						Length (m)	30
						Width (m)	2.1
						Avg. depth (m)	0.65

Context No.	Type	Fill Of	Width (m)	Depth (m)	Description	Finds	Date
20300	Layer		2.1	0.3	Ploughsoil. Mid grey silty sand with diffused pebbles and moderate flint		
20301	Layer		2.1	0.2	Subsoil. Mid brown silty sand with occasional pebbles		
20302	Layer		2.1	0.2	Colluvial Layer. Mid red brown silty sand with occasional pebbles and rate flint		
20303	Layer		2.1	0.05	Natural. Mid red brown gravelly silty sand.		

#### Trench 204

General description						Orientation	N-S
Trench devoid of archaeology. Consists of ploughsoil and subsoil overlying natural sandy gravel.						Length (m)	30
						Width (m)	2.1
						Avg. depth (m)	0.6

Context No.	Type	Fill Of	Width (m)	Depth (m)	Description	Finds	Date
20400	Layer		2.1	0.3	Ploughsoil. Mid grey silty sand with frequent pebbles and moderate flint		
20401	Layer		2.1	0.15	Subsoil. Light brown silty sand with occasional pebbles		
20402	Layer		2.1	0.1	Colluvial Layer. Mid red brown silty sand with occasional flint		
20403	Layer		2.1	0.05	Natural. Mid red brown gravelly silty sand		

#### Trench 205

General description						Orientation	E-W
Trench revealed a ditch and a pit. Consists of ploughsoil and subsoil overlying sandy gravel natural.						Length (m)	30
						Width (m)	2.1
						Avg. depth (m)	0.6

Context No.	Type	Fill Of	Width (m)	Depth (m)	Description	Finds	Date
20500	Layer			0.34	Ploughsoil. Dark grey Clayey silt		
20501	Layer			0.1	Subsoil. Light brown sandy silt		

20502	Layer				Natural. Sandy gravel		
20503	Cut		0.93	0.51	Ditch. Curvilinear running to terminus		
20504	Fill		0.93	0.51	Primary Fill. Soft light brown silty sand		
20505	Cut		1.4	0.14	Pit		
20506	Fill	20505	1.4	0.14	Primary Fill. Mod compact light grey with white mottling silty sand		
20507	Cut		0.41	0.24	Ditch. Terminus		
20508	Fill	20507	0.41	0.24	Primary Fill. Soft light greyish brown silty sand		

#### Trench 206

General description					Orientation	N-S
Trench devoid of archaeology. Consists of ploughsoil and subsoil overlying natural sandy gravel.					Length (m)	30
					Width (m)	2.1
					Avg. depth (m)	0.7

Context No.	Type	Fill Of	Width (m)	Depth (m)	Description	Finds	Date
20600	Layer		2.1	0.3	Ploughsoil. Dark brown silty sand. Occasional flint, diffused pebbles		
20601	Layer		2.1	0.3	Subsoil. Mid brown silty sand with moderate flint and occasional pebbles		
20602	Layer		2.1	0.1	Natural. Mid red brown gravelly silty sand.		

#### Trench 207

General description					Orientation	N-S
Trench devoid of archaeology. Consists of ploughsoil and subsoil overlying natural sandy gravel.					Length (m)	30
					Width (m)	2.1
					Avg. depth (m)	0.46

Context No.	Type	Fill Of	Width (m)	Depth (m)	Description	Finds	Date
20700	Layer		2.1	0.25	Ploughsoil. Mid grey silty sand with occasional flint and frequent pebbles		
20701	Layer		2.1	0.2	Subsoil. Light brown silty sand with occasional pebbles		
20702	Layer		2.1	0.01	Colluvial Layer. Mid red brown silty sand with occasional flint		

#### Trench 208

General description					Orientation	E-W
Trench devoid of archaeology. Consists of ploughsoil and subsoil overlying natural sandy gravel.					Length (m)	30
					Width (m)	2.1
					Avg. depth (m)	0.6

Context No.	Type	Fill Of	Width (m)	Depth (m)	Description	Finds	Date
20800	Layer		2.1	0.32	Ploughsoil. Mid grey silty sand with occasional flint and frequent pebbles		
20801	Layer		2.1	0.23	Subsoil. Light brown silty sand with occasional pebbles		
20802	Layer		2.1	0.05	Colluvial Layer. Mid red brown silty sand with occasional flint.		

Trench 209								
General description						Orientation		N-S
Trench devoid of archaeology. Consists of ploughsoil overlying natural sandy gravel.						Length (m)		30
						Width (m)		2.1
						Avg. depth (m)		0.35
Context No.	Type	Fill Of	Width (m)	Depth (m)	Description	Finds	Date	
20900	Layer		2.1	0.3	Ploughsoil. Mid grey silty sand with occasional flint and frequent pebbles			
20901	Layer		2.1	0.05	Natural. Mid brown gravelly silty sand			
Trench 210								
General description						Orientation		E-W
Trench devoid of archaeology. Consists of ploughsoil and subsoil overlying natural sandy gravel.						Length (m)		30
						Width (m)		2.1
						Avg. depth (m)		0.45
Context No.	Type	Fill Of	Width (m)	Depth (m)	Description	Finds	Date	
21000	Layer		2.1	0.25	Ploughsoil. Dark brown silty sand. Occasional flint, diffused pebbles			
21001	Layer		2.1	0.3	Subsoil. Mid brown silty sand; occasional flint, moderate pebbles.			
21002	Layer		2.1	0.1	Natural. Mid red brown gravelly silty sand; occasional mottling of yellow sand			
Trench 211								
General description						Orientation		NE-SW
Trench revealed one pit. Consists of ploughsoil and subsoil overlying natural geology of silty sand and gravel.						Length (m)		30
						Width (m)		2.1
						Avg. depth (m)		0.65
Context No.	Type	Fill Of	Width (m)	Depth (m)	Description	Finds	Date	
21100	Layer		2.1	0.43	Ploughsoil. Dark brown silty sand. Occasional flint, diffused pebbles	Fe nail		
21101	Layer		2.1	0.2	Subsoil. Mid brown silty sand with occasional flint and moderate pebbles			
21102	Layer		2.1	0.02	Natural. Mid red brown gravelly silty sand.			
21103	Cut		0.95	0.15	Pit			
21104	Fill	21103	0.95	0.15	Primary Fill. Loose light grey silty sand	Fe Horse-shoe	C12-14th	
21105	Cut		0.71	0.15	Natural Feature			
Trench 212								
General description						Orientation		E-W
Trench devoid of archaeology. Consists of ploughsoil and subsoil overlying natural sandy gravel.						Length (m)		30
						Width (m)		2
						Avg. depth (m)		0.25
Context No.	Type	Fill Of	Width (m)	Depth (m)	Description	Finds	Date	



21200	Layer		2.1	0.25	Ploughsoil. Mid grey silty sand with occasional flint and frequent pebbles		
21201	Layer		2.1	0.15	Subsoil. Light brown silty sand with occasional pebbles		
21202	Layer		2.1	0.05	Colluvial Layer. Mid red brown silty sand with occasional flint		

#### Trench 213

General description					Orientation	N-S
Trench devoid of archaeology. Consists of ploughsoil and subsoil overlying natural sandy gravel.					Length (m)	30
					Width (m)	2.1
					Avg. depth (m)	0.52

Context No.	Type	Fill Of	Width (m)	Depth (m)	Description	Finds	Date
21300	Layer		2	0.3	Ploughsoil. Mid grey silty sand with occasional flint and frequent pebbles		
21301	Layer		2.1	0.2	Subsoil. Mid brown silty sand with occasional pebbles		
21302	Layer		2.1	0.02	Natural. Mid brown to mid red gravelly silty sand		

#### Trench 214

General description					Orientation	NE-SW
Trench revealed a ditch. Consists of ploughsoil and subsoil overlying natural geology of sandy gravel.					Length (m)	30
					Width (m)	2.1
					Avg. depth (m)	0.6

Context No.	Type	Fill Of	Width (m)	Depth (m)	Description	Finds	Date
21400	Layer		2.1	0.3	Ploughsoil. Dark brown silty sand. Occasional flint, diffused pebbles		
21401	Layer		2.1	0.2	Subsoil. Mid brown silty sand. Occasional pebbles, moderate flint		
21402	Layer		2.1	0.1	Natural. Mid red brown gravelly silty sand.		
21403	Cut		1.13	0.32	Ditch. N/S. Heavily truncated by machine		
21404	Fill	21403	1.13	0.32	Primary Fill. Mod compact light yellowish grey silty sand		

#### Trench 215

General description					Orientation	N-S
Trench devoid of archaeology. Consists of ploughsoil and subsoil overlying natural sandy gravel.					Length (m)	30
					Width (m)	2
					Avg. depth (m)	0.55

Context No.	Type	Fill Of	Width (m)	Depth (m)	Description	Finds	Date
21500	Layer		2.1	0.25	Ploughsoil. Mid grey silty sand with occasional flint and frequent pebbles		
21501	Layer		2.1	0.25	Subsoil. Mid light brown silty sand with occasional pebbles		
21502	Layer		2.1	0.05	Natural. Mid red brown gravelly silty sand		

#### Trench 216

General description						Orientation		E-W	
Trench revealed one ditch. Consists of ploughsoil overlying natural geology of sandy gravel.						Length (m)		30	
						Width (m)		2.1	
						Avg. depth (m)		0.8	
Context No.	Type	Fill Of	Width (m)	Depth (m)	Description	Finds	Date		
21600	Layer		2.1	0.38	Ploughsoil. Mid greyish brown, silt				
21601	Cut		0.84	0.16	Ditch. C/o linear ditch running NE-SW				
21602	Fill	21601	0.84	0.16	Primary Fill. Reddish brown, sandy silt				
21603	Layer				Natural. Sandy silt, large amount of gravel				
Trench 217									
General description						Orientation		NE-SW	
Trench devoid of archaeology. Consists of ploughsoil and subsoil overlying natural sandy gravel.						Length (m)		30	
						Width (m)		2.1	
						Avg. depth (m)		0.7	
Context No.	Type	Fill Of	Width (m)	Depth (m)	Description	Finds	Date		
21700	Layer		2.1	0.35	Ploughsoil. Dark brown silty sand. Occasional flint, diffused pebbles				
21701	Layer		2.1	0.2	Subsoil. Mid brown silty sand; occasional flint, moderate pebbles				
21702	Layer		2.1	0.15	Natural. Mid red brown gravelly silty sand.				
Trench 218									
General description						Orientation		NE-SW	
Trench devoid of archaeology. Consists of ploughsoil and subsoil overlying natural sandy gravel.						Length (m)		30	
						Width (m)		2.1	
						Avg. depth (m)		0.6	
Context No.	Type	Fill Of	Width (m)	Depth (m)	Description	Finds	Date		
21800	Layer		2.1	0.35	Ploughsoil. Dark brown silty sand. Occasional flint, diffused pebbles				
21801	Layer		2.1	0.15	Subsoil. Mid brown silty sand. Occasional pebbles, moderate flint				
21802	Layer		2.1	0.1	Natural. Mid red brown gravelly silty sand				
Trench 219									
General description						Orientation		E-W	
Trench devoid of archaeology. Consists of ploughsoil and subsoil overlying natural sandy gravel.						Length (m)		30	
						Width (m)		2.1	
						Avg. depth (m)		0.55	
Context No.	Type	Fill Of	Width (m)	Depth (m)	Description	Finds	Date		
21900	Layer		2.1	0.25	Ploughsoil. Mid grey silty sand with occasional flint and frequent pebbles				
21901	Layer		2.1	0.25	Subsoil. Light brown silty sand with occasional pebbles				
21902	Layer		2.1	0.05	Colluvial Layer. Mid red brown silty sand with occasional flint				

Trench 220							
General description					Orientation		E-W
Trench revealed two pits and three ditches. Consists of ploughsoil and subsoil overlying a sandy gravel natural.					Length (m)		30
					Width (m)		2
					Avg. depth (m)		0.4
Context No.	Type	Fill Of	Width (m)	Depth (m)	Description	Finds	Date
22000	Layer		2	0.38	Ploughsoil. Dark greyish brown mod compact sandy silt		
22001	Layer		2	0.07	Subsoil. Firm mid brown sandy clay		
22002	Layer		2		Natural. Mid brownish orange gravelly sand		
22003	Cut		0.8	0.09	Pit. Cut of circular pit		
22004	Fill	22003	0.8	0.09	Primary Fill. Loose light grey sandy gravel		
22005	Cut		2.82	0.54	Ditch. Ditch running NW/SE. Not bottomed due to depth		
22006	Fill	22005	2.82		Primary Fill. Loose mid orangey brown sandy sily		
22007	Fill	22005	2.82	0.34	Secondary Fill. Dark greyish brown loose silty sand		
22008	Cut		1.33	0.13	Ditch. NW/SE		
22009	Fill	22008	1.33	0.13	Primary Fill. Dark greyish brown loose sandy silt		
22010	Cut		0.8	0.09	Pit		
22011	Fill	22010	0.8	0.09	Primary Fill. Loose light grey sandy silt		
22012	Cut		1.65	0.14	Ditch. E/W		
22013	Fill	22012	1.65	0.14	Primary Fill. Light grey loose sandy silt		
Trench 221							
General description					Orientation		NE-SW
Trench revealed two ditches. Consists of ploughsoil overlying a sandy gravel natural.					Length (m)		23
					Width (m)		10
					Avg. depth (m)		0.35
Context No.	Type	Fill Of	Width (m)	Depth (m)	Description	Finds	Date
22100	Layer		10	0.36	Ploughsoil. Soft mid brownish grey sandy silt.		
22101	Layer		10	0.07	Subsoil. Firm mid brown sandy clay		
22102	Layer				Natural. Friable mid brownish orange sandy gravel.		
22103	Cut		1.27	0.4	Natural Feature. Mid brown sandy silt fill, occasional stones		
22104	Cut		0.7	0.15	Ditch		
22105	Fill	22104	0.7	0.15	Primary Fill. Mid brown sandy silt		
22106	Cut		0.72	0.23	Ditch		
22107	Fill	22106	0.72	0.23	Primary Fill. Mid brown sandy silt		
22108	Cut		0.92	0.13	Natural Feature. Mid brown silty sand		
22109	Cut		0.65	0.15	Ditch. Same as 22106		

22110	Fill	22109	0.65	0.15	Primary Fill. Loose light brownish grey sandy silt		
22111	Cut		0.59	0.08	Ditch. Same as 22104		
22112	Fill	22111	0.59	0.08	Primary Fill. Loose light brownish grey sandy silt		

Trench 222

General description					Orientation	E-W
Trench revealed a ditch. Consists of ploughsoil, subsoil and a sequence of two colluvial layers overlying a natural geology of sandy clay.					Length (m)	30
					Width (m)	1.8
					Avg. depth (m)	

Context No.	Type	Fill Of	Width (m)	Depth (m)	Description	Finds	Date
22200	Layer		1.8	0.28	Ploughsoil. Soft mid brownish grey sandy silt.		
22201	Layer		1.8	0.22	Subsoil. Firm Mid orangish brown sandy clay		
22202	Layer		1.8	0.32	Colluvial Layer. Soft mid brown sandy silt.	Pot, Flint	MBA-IA
22203	Layer		1.8	0.18	Colluvial Layer. Soft light yellowish brown sandy silt.	Pot, Flint	MBA-IA
22204	Layer		1.8	0.12	Natural. Firm mid reddish brown sandy clay		
22205	Cut		0.8	0.24	Tree Throw		
22206	Fill	22205	0.8	0.24	Primary Fill	Pot, Flint	MBA-IA
22207	Cut		1.32	0.36	Ditch		
22208	Fill	22207	1.32	0.2	Secondary fill. Brown orange clay silt	Flint	
22209	Fill	22207	0.94	0.16	Primary Fill. Dark orange brown, silty clay.		

Trench 223

General description					Orientation	E-W
Trench devoid of archaeology. Consists of ploughsoil, subsoil and a colluvial layer overlying a sandy clay natural.					Length (m)	30
					Width (m)	1.8
					Avg. depth (m)	0.7

Context No.	Type	Fill Of	Width (m)	Depth (m)	Description	Finds	Date
22300	Layer		1.8	0.35	Ploughsoil. Soft mid brownish grey sandy silt		
22301	Layer		1.8	0.06	Subsoil. Firm mid orange brown sandy clay.		
22302	Layer		1.8	0.23	Colluvial Layer. Soft light greyish brown silty sand.		
22303	Layer		1.8	0.13	Colluvial Layer. Firm mid reddish brown sandy clay.		
22304	Layer		1.8		Natural. Compact mid reddish brown sandy clay		
22305	Cut		1.93	0.27	Natural Feature. Natural pit.		

Trench 224

General description					Orientation	NW-SE
Trench devoid of archaeology. Consists of ploughsoil, subsoil and a colluvial layer overlying a sandy clay natural.					Length (m)	30
					Width (m)	1.8

						Avg. depth (m)	0.7
Context No.	Type	Fill Of	Width (m)	Depth (m)	Description	Finds	Date
22400	Layer		1.8	0.32	Ploughsoil. Soft mid brownish grey sandy silt.		
22401	Layer		1.8	0.09	Subsoil. Firm, light orange brown sandy clay		
22402	Layer		1.8	0.32	Colluvial Layer. Firm mid reddish brown sandy clay		
22403	Layer		1.8		Natural. Compact mid reddish brown sandy clay with gravels.		
Trench 225							
General description						Orientation	N-S
Trench revealed a ditch. Consists of ploughsoil and subsoil overlaying natural geology of silty sand and gravel.						Length (m)	30
						Width (m)	2.2
						Avg. depth (m)	0.7
Context No.	Type	Fill Of	Width (m)	Depth (m)	Description	Finds	Date
22500	Layer			0.3	Ploughsoil. Loose dark grey, silty sand.		
22501	Layer			0.4	Subsoil. Loose light orangey brown, silty sand.		
22502	Layer				Natural. Loose very pale yellowish brown, silty sand and gravel.		
22503	Cut		0.9	0.14	Ditch. NE/SW		
22504	Fill	22503	0.9	0.14	Primary Fill. Light grey brown mid compact sandy silt	Pot	MBA-IA
Trench 226							
General description						Orientation	N-S
Trench devoid of archaeology. Consists of topsoil and subsoil overlaying natural geology of silty sand and gravel.						Length (m)	30
						Width (m)	2.2
						Avg. depth (m)	0.45
Context No.	Type	Fill Of	Width (m)	Depth (m)	Description	Finds	Date
22600	Layer			0.25	Ploughsoil. Loose dark grey, silty sand.		
22601	Layer			0.2	Subsoil. Loose pale orangey brown, silty sand.		
22602	Layer				Natural. Loose very pale orangey brown, silty sand and gravel.		
Trench 227							
General description						Orientation	E-W
Trench devoid of archaeology. Consists of ploughsoil and subsoil overlying natural geology of gravel and yellowish brown sandy silt.						Length (m)	30
						Width (m)	2.3
						Avg. depth (m)	0.65
Context No.	Type	Fill Of	Width (m)	Depth (m)	Description	Finds	Date
22700	Layer			0.3	Ploughsoil. Dark greyish brown sandy silt.		
22701	Layer			0.35	Subsoil. Light yellowish brown sandy silt.		

22702	Layer				Natural. Gravel and light yellowish brown sandy silt.		
Trench 228							
General description					Orientation		E-W
Trench devoid of archaeology and consists of topsoil and subsoil overlaying natural geology of silty sand and gravel.					Length (m)		30
					Width (m)		2.2
					Avg. depth (m)		0.4
Context No.	Type	Fill Of	Width (m)	Depth (m)	Description	Finds	Date
22800	Layer			0.25	Topsoil. Loose dark greyish brown, silty sand.		
22801	Layer			0.15	Subsoil. Loose light orangey brown, silty sand.		
22802	Layer				Natural. Loose very pale yellowish brown, silty sand and gravel.		
Trench 229							
General description					Orientation		NE-SW
Trench devoid of archaeology. Consists of ploughsoil and subsoil overlying natural geology of sandy silt and gravel.					Length (m)		30
					Width (m)		2.3
					Avg. depth (m)		0.7
Context No.	Type	Fill Of	Width (m)	Depth (m)	Description	Finds	Date
22900	Layer			0.3	Ploughsoil. Mid greyish brown sandy silt.		
22901	Layer			0.35	Subsoil. Light yellowish brown sandy silt.		
22902	Layer				Natural. Light yellowish brown sandy silt with patches of gravel.		
Trench 230							
General description					Orientation		E-W
Trench devoid of archaeology. Consists of topsoil, subsoil and colluvium towards the western end, overlaying natural geology of silty sand.					Length (m)		30
					Width (m)		2.2
					Avg. depth (m)		0.7
Context No.	Type	Fill Of	Width (m)	Depth (m)	Description	Finds	Date
23000	Layer			0.25	Ploughsoil. Loose dark greyish brown, silty sand.		
23001	Layer			0.3	Subsoil. Soft light orangey brown, silty sand.		
23002	Layer			0.25	Colluvial Layer. Soft light reddish brown, silty sand.		
23003	Layer				Natural. Soft light orangey brown, silty sand.		
Trench 231							
General description					Orientation		N-S
Trench devoid of archaeology. Consists of ploughsoil and subsoil overlying natural geology of brown brickearth with patches of gravel.					Length (m)		30
					Width (m)		2.3
					Avg. depth (m)		0.5

Context No.	Type	Fill Of	Width (m)	Depth (m)	Description	Finds	Date
23100	Layer			0.3	Ploughsoil. Dark greyish brown sandy silt.		
23101	Layer			0.2	Subsoil. Light yellowish brown sandy silt.		
23102	Layer				Natural. Light brown brickearth with patches of gravel.		

#### Trench 232

General description					Orientation		N-S
Trench devoid of archaeology. Consists of ploughsoil and subsoil overlying natural geology of sandy silt and brickearth.					Length (m)		30
					Width (m)		2.3
					Avg. depth (m)		0.7

Context No.	Type	Fill Of	Width (m)	Depth (m)	Description	Finds	Date
23200	Layer			0.3	Ploughsoil. Mid greyish brown sandy silt.		
23201	Layer			0.35	Subsoil. Light brown sandy silt.		
23202	Layer				Natural. Light yellow sandy silt with frequent patches of gravel.		

#### Trench 233

General description					Orientation		NE-SW
Trench revealed a ditch. Consisted of ploughsoil and subsoil overlaying natural sandy silt with patches of gravel.					Length (m)		30
					Width (m)		2.1
					Avg. depth (m)		0.58

Context No.	Type	Fill Of	Width (m)	Depth (m)	Description	Finds	Date
23300	Layer		2.1	0.3	Ploughsoil. Mid greyish brown sandy silt		
23301	Layer		2.1	0.12	Subsoil. Mid brownish orange sandy silt		
23302	Layer		2.1	0.15	Natural. light yellowish brown sandy silt with patches of gravel		
23303	Cut		0.54	0.08	Ditch. linear ditch running NW-SE across the centre of the trench, cuts subsoil.		
23304	Fill	23303	0.54	0.08	Secondary Fill. Light greyish brown sandy silt	CBM	C19th

#### Trench 234

General description					Orientation		E-W
Trench devoid of archaeology. Consists of ploughsoil and subsoil overlying natural geology of gravel and brown sandy silt.					Length (m)		30
					Width (m)		2.3
					Avg. depth (m)		0.55

Context No.	Type	Fill Of	Width (m)	Depth (m)	Description	Finds	Date
23400	Layer			0.3	Ploughsoil. Mid grey brown sandy silt		
23401	Layer			0.2	Subsoil. Mid brown silty sand.		
23402	Layer				Natural. Mixed sand and gravels		

#### Trench 235

General description					Orientation		NE-SW
					Length (m)		30

Trench devoid of archaeology. Consists of ploughsoil and subsoil overlying natural geology of sandy silt with patches of gravel.						Width (m)	2.3
						Avg. depth (m)	0.55
Context No.	Type	Fill Of	Width (m)	Depth (m)	Description	Finds	Date
23500	Layer			0.3	Ploughsoil. Dark greyish brown sandy silt.		
23501	Layer			0.2	Subsoil. Light yellowish brown sandy silt.		
23502	Layer				Natural. Light yellowish brown sandy silt with frequent patches of gravel.		
Trench 236							
General description						Orientation	NW-SE
Trench devoid of archaeology. Consists of ploughsoil and subsoil overlying natural geology of gravel and brown sandy silt.						Length (m)	30
						Width (m)	2.3
						Avg. depth (m)	0.55
Context No.	Type	Fill Of	Width (m)	Depth (m)	Description	Finds	Date
23600	Layer			0.33	Ploughsoil. Dark grey mod compact sandy silt		
23601	Layer			0.3	Subsoil. Mid grey brown mod compact sandy silt		
23602	Layer				Natural. Mid orangey brown gravelly clay		
Trench 237							
General description						Orientation	NW-SE
Trench revealed a tree throw containing pottery. Consists of ploughsoil and subsoil overlying natural geology of gravel and brown sandy clay.						Length (m)	30
						Width (m)	2.3
						Avg. depth (m)	0.6
Context No.	Type	Fill Of	Width (m)	Depth (m)	Description	Finds	Date
23700	Layer			0.3	Ploughsoil. Dark grey mod compact sandy silt		
23701	Layer			0.29	Subsoil. Light greyish orange mod compact sandy silt		
23702	Layer				Natural. Mid orangey brown gravelly sand		
23703	Cut		0.64	0.08	Natural Feature. Mid orange brown sandy silt		
23704	Cut		0.3	0.06	Tree Throw. Irregular shaped feature, possible tree-throw hole, some pot fragments found.		
23705	Fill	23704	0.3	0.06	Other Fill. Mid greyish brown sandy silt, pot fragments	Pot	MBA-IA
Trench 238							
General description						Orientation	NW-SE
Trench revealed one ditch. Consists of ploughsoil and subsoil overlaying sandy silt natural with patches of gravel.						Length (m)	30
						Width (m)	2.1
						Avg. depth (m)	0.6
Context No.	Type	Fill Of	Width (m)	Depth (m)	Description	Finds	Date
23800	Layer		2.1	0.3	Ploughsoil. Mid greyish brown sandy silt		
23801	Layer		2.1	0.18	Subsoil. Mid brownish orange sandy silt		



23802	Layer		2.1	0.12	Natural. Light brown orange, sandy silt with patches of gravel		
23803	Cut		0.84	0.14	Ditch. linear ditch running WSW- ENE across NNE end of the trench		
23804	Fill	23803	0.84	0.14	Secondary Fill. Light greyish brown sandy silt		

#### Trench 239

General description					Orientation		E-W
Trench devoid of archaeology. Consists of topsoil and subsoil overlaying natural geology of silty sand and gravel.					Length (m)		30
					Width (m)		2.2
					Avg. depth (m)		0.6

Context No.	Type	Fill Of	Width (m)	Depth (m)	Description	Findings	Date
23900	Layer			0.25	Ploughsoil. Loose dark greyish brown, silty sand.		
23901	Layer			0.35	Subsoil. Soft light yellowish brown, silty sand.		
23902	Layer				Natural. Soft light orangey brown, silty sand and gravel.		

#### Trench 240

General description					Orientation		N-S
Trench revealed two ditches. Consists of ploughsoil and subsoil overlaying natural geology of silty sand and gravel.					Length (m)		30
					Width (m)		2.2
					Avg. depth (m)		0.4

Context No.	Type	Fill Of	Width (m)	Depth (m)	Description	Findings	Date
24000	Layer			0.2	Ploughsoil. Loose mid-greyish brown, sandy silt.		
24001	Layer			0.2	Subsoil. Soft light greyish brown, silty sand.		
24002	Layer				Natural. Soft light greyish white and orangey brown, silty sand and gravel.		
24003	Cut		0.36	0.06	Ditch. linear NE-SW across S end of the trench		
24004	Fill	24003	0.36	0.06	Secondary Fill. Mid greyish brown sandy silt		
24005	Cut		1.31	0.25	Ditch. NW/SE		
24006	Fill	24005	1.31	0.25	Primary Fill. Light grey brown mod compact sandy silt	Pot, Flint, Charcoal	ENeo/ MBA
24007	Cut		1.28	0.26	Natural Feature. Natural pit. Light grey sandy silt		

## Appendix B Finds Reports

---

### B.1 Prehistoric Pottery

By Alex Davies

#### Introduction

- B.1.1 The evaluation recovered 198 sherds (1028g) of prehistoric pottery. This includes 13 sherds (26g) from environmental sample 1 from context 6404.
- B.1.2 Most of the material is flint tempered, and the only diagnostic sherds are middle Bronze Age, and possibly late Bronze Age. Pottery from one context, 24006, might be early Neolithic. The spot-date ranges for most of the contexts are broad, reflecting the continuing use of flint as a tempering agent in the region over long periods of time (Evans *et al.* 2016, 70, 105, 160, 379-80), and the small and fragmentary nature of the assemblage dominated by body sherds. The large size of the site and scattered nature of the pottery producing contexts argues against spot-dating the entire assemblage to the middle Bronze Age on the basis of the three diagnostic contexts.
- B.1.3 The material is poorly to moderately well preserved with a mean sherd weight of 5.2g.

#### Methodology

- B.1.4 Pottery from each context was scanned with spot-dates given based on the latest material present. Fabrics were recorded in order of their approximate frequency in any one context. The two most common inclusion types were noted, using the following fabric codes:
- Fl Flint
  - Qs Quartz sand
  - Sh Shell (voids; not certainly present)
  - Ve Vegetal (grass, chaff; voids)
- B.1.5 The grade of the fabric was also recorded with a number suffix, ranging from 1 (fine) to 4 (very coarse).

#### Early Neolithic?

- B.1.6 Context 24006 produced a small assemblage of pottery that stands out from the rest of the group. Like the majority of the sherds it is flint-tempered, but the fabric is poorly sorted and the sherds have a smoothed exterior and may date to the early Neolithic. This spot-date is uncertain and the sherds might be middle Bronze Age. A date later than the middle Bronze Age is less likely.

#### Middle and late Bronze Age

- B.1.7 A large sherd from a Deverel-Rimbury jar/urn with a fingertipped cordon was found in context 12307. This is the only unambiguous middle Bronze Age vessel, although another similar vessel was found in the same trench in context 12310. This second vessel has a slight angular shoulder that is fingertipped, suggesting it could be late Bronze Age, although a middle Bronze Age date is preferred. These two contexts also produced sherds in a fabric (VeSh3) containing vegetal voids and *possible* shell voids. The same fabric was found in context 12809. The associations in 12307 and

12310 demonstrate that the material is middle Bronze Age. None of the VeSh3 sherds were diagnostic. Vegetal fabrics were a minor presence in the nearby Mucking middle Bronze Age assemblage (Evans *et al.* 2016, 105-9).

- B.1.8 Most of the contexts were spot-dated to the middle Bronze Age to Iron Age as they only contained undiagnostic flint-tempered body sherds. Flint was the dominant inclusion type at Mucking during the middle late Bronze Age to early Iron Age, being replaced by sand by the later middle Iron Age where glauconitic material was also present (Evans *et al.* 2016, 105, 160, 379-80). None of the sherds were dominated by sand and glauconitic sand was not present, making a middle Iron Age date for any of the vessels unlikely. Some may belong to the early Iron Age, although as a group a later Bronze Age date is favoured.

### Retention

- B.1.9 The pottery has future research potential and should all be retained.

Context	Count	Weight (g)	Fabric	Spot-date	Comment
2004	2	3	FIQs2	MBA-IA	Tiny
6404	47	200	FI3; FIQs2	MBA-IA	Includes 13/26g from sample 1
7704	17	26	FI2	MBA-IA	
10925	28	28	FI2	MBA-IA	
12305	19	203	FI4	MBA/LBA	Too coarse to be IA
12307	12	307	FI3; VeSh3	MBA	Large Dev-Rim sherd with fingertipped cordon (FI3)
12310	12	307	FI3; VeSh3	MBA/LBA	Jar/'urn' with slight angle and fingertipped shoulder (FI3). More likely MBA, but angle could be LBA
12809	9	31	FI2; VeSh3	MBA-IA	Burnished
22202	10	11	FI2	MBA-IA	
22203	6	13	FIQs2	MBA-IA	
22206	12	22	FIQs2	MBA-IA	
22208	14	41	FIQs2	MBA-IA	
22504	1	3	FI2	MBA-IA	
23705	4	4	FI2	MBA-IA	
24006	5	9	FI3 poorly sorted	E Neo or MBA	Small so hard to tell, but appears different from rest of assemblage. Poorly sorted fabric, smoothed surface

Table 1: Prehistoric pottery

## B.2 Late Iron Age and Roman Pottery

By Ed Biddulph

### Introduction

- B.2.1 Eight sherds of late Iron Age and Roman pottery were recovered from the evaluation (Table 2). The small assemblage was quantified by sherd count and weight in grammes. Fabrics were assigned codes devised by the Essex County Council Field Archaeology Unit (cf. Biddulph *et al.* 2015). The assemblage comprised body sherds only; no forms could be identified.
- B.2.2 Late Iron Age or early Roman activity is indicated by the presence of grog-tempered ware (GROG) in context 12313. Fragments of a flint-tempered fabric (given fabric code MICW) recovered with the grog-tempered ware is probably earlier, possibly being Bronze Age or Iron Age.
- B.2.3 The pottery from contexts 704 and 14010 points to late Roman activity. Hadham oxidised ware (HAX), collected from context 704, was produced at Much Hadham in Hertfordshire and exported widely across south-eastern Britain from the later 3rd century onwards. Flint-tempered Rettendon-type ware (RET), from context 14010, was manufactured in Rettendon and other sites, including Chelmsford and Heybridge, during the late 3rd and 4th centuries (Going 1987, 10; Biddulph *et al.* 2015).
- B.2.4 The mean sherd weight (weight divided by number of sherds) of the assemblage is 2.5g. While the pottery points to late Iron Age/early Roman and late Roman activity in the vicinity of the site, the condition and size of the assemblage suggest that the material had undergone several episodes of redeposition and had been deposited incidentally, for example through agricultural practices.

Context	Fabric	Description	Count	Weight (g)	Spot-date
704	HAX	Hadham oxidised ware (HAD OX)	1	6	AD 250-410
12313	GROG	Grog-tempered ware (SOB GT)	2	4	50 BC-AD 70
	MICW	Miscellaneous Iron Age coarse tempered fabric	3	3	
14010	GRS	Sandy grey ware	1	4	AD 270-400
	RET	Rettendon-type ware	1	3	
Total			8	20	

Table 2: Quantification of late Iron Age and Roman fabrics (codes in brackets from Tomber and Dore 1998)

## B.3 Medieval Pottery

By John Cotter

### Introduction

- B.3.1 A total of 39 sherds of medieval and post-medieval pottery weighing 1634g were recovered from four contexts. Ordinary domestic wares were recovered.
- B.3.2 All the pottery was scanned during the present assessment and spot-dates were provided for each context. Each context group was quantified by sherd count and weight and recorded on a spot-dating spreadsheet. The pottery is fragmentary but several large fresh sherds are present.
- B.3.3 The context spot-date is the date-bracket during which the latest pottery types or fabrics are estimated to have been produced or were in general circulation. Comments on the range of fabrics were recorded, usually with mention of vessel form (jugs, bowls etc.) and any other attributes worthy of note (eg. decoration etc.). Fabric codes referred to are those of the Museum of London (MoLA 2014). Where appropriate these are cross-referenced with the fabric codes of Essex County Council (Cotter 2000, 12-13). The range of pottery is described in some detail in the spreadsheet (Table 3) and is therefore only summarised below.

### Description

Context	Spot-date	Count	Weight (g)	Comments
10912	c 970-1100?	2	5	1x bo (body sherd) fine-medium dull grey-brown sandyware with rare organic inclusions - possibly London early medieval sandy ware (EMS)? Sherd sooted ext (otherwise possibly Late Iron Age/early Roman?). 1x scrap (1g) Saxon organic-tempered ware (CHAF, c 400-750)
16803	c 1140-1220	10	556	1 vessel. Cooking pot profile in London shelly-sandy ware (SSW). Classic SSW form with neckless globular body, short horizontal/downturned flanged rim, sagging base and traces of applied thumbed strip decoration on shoulder/body in a chevron or possibly a crossed 'X' pattern. Wheel-turned. Sooted. ILLUS?
18204	c 1525-1550/75	16	953	Large fresh sherds, several joining. All post-medieval red earthenware (PMR) but smooth early-looking fabric (borderline PMRE/PMR, Essex Fabric 40EA). Incl complete base from cylindrical mug with a thumbed/faceted base with a broad band of horizontal grooved decoration on body and a dark brown lustrous glaze (almost CSTN/PMBL). Also complete pad base/lower wall small drinking jug with similar smooth fabric and dark brown glaze (possibly copying German stoneware jugs c 1525+). 3 large sherds from body of an unglazed bunghole jar with complete plain bunghole with bulged

Context	Spot-date	Count	Weight (g)	Comments
				'collar' and scar from strap handle. 3x rims incl 2 from unglazed storage jars (bung-hole vessels?) & 1 with int brown glaze. Also 1x unglazed bowl sherd with broken flanged rim. Pottery group, overall, probably mid 16C
18305	c 1480-1550	11	120	6x post-medieval slip-painted redwares (Essex Fabric 40SL, c 1480-1550; London Fabric PMSL). Latter = body sherds probably from unglazed jugs. 5x early PMR (40EA) incl jug rim and rim from wide bowl, unglazed apart from some glaze specks
<b>Total</b>		<b>39</b>	<b>1634</b>	

Table 3: Description of post-Roman pottery by context

### Discussion

- B.3.4 The pottery comprises ordinary domestic wares typical of this part of south Essex and covers a date range from the early or middle Saxon period through to the 16th century, though with many gaps evident.
- B.3.5 There is a single small sherd/scrap of early to middle Saxon organic-tempered ware (Fabric code: CHAF) but this appears to be residual in a context 10912 also containing a single sherd tentatively identified as a medieval sandy ware (?EMS, c 970-1100). The latter, however, might possibly be of late Iron Age/early Roman date?
- B.3.6 Context 16803 produced a complete (reconstructable) medieval cooking pot profile in London shelly-sandy ware (SSW), datable to c 1140-1220 - a notable find which would benefit from illustration at some stage.
- B.3.7 Contexts 18204 and 18305 produced large fresh sherds in a limited range of early post-medieval Essex redware fabrics (40EA and 40SL) including vessels decorated with white slip painting (40SL). The latter context dates to c 1480-1550, while the former probably dates to around the middle of the 16th century (ie. the 'Tudor' period).

### Recommendations regarding the conservation, discard and retention of material

- B.3.8 The pottery here has potential to inform research through re-analysis. It should all therefore be retained and properly catalogued and reported at some future date - along with material from any subsequent formal excavations in this area.

## B.4 Flint

By Lawrence Billington

### Introduction

- B.4.1 A total of 81 worked flints was recovered during the evaluation, alongside 443g (77 fragments) of unworked burnt flint. The assemblage is quantified by type and context in Table 4.
- B.4.2 The assemblage was catalogued directly onto an Excel spreadsheet and the artefacts were classified according to a system of broad artefact/debitage types based on standard definitions for post-glacial lithic assemblages from southern Britain (e.g. Bamford 1985, 72-77; Healy 1988, 48-9; Butler 2005). Additional information on selected technological and non-metric attributes of the material (including platform type/preparation, hammer mode and dorsal cortex coverage) was also recorded using standard classifications and terminology based largely on those set out by Inizan and colleagues (1999).

### Raw material and condition

- B.4.3 The entire assemblage is made up of flint, generally fine grained and of good quality but with considerable variability in terms of colour and texture. Surviving cortical surfaces indicate that most of the flint derives from relatively small rounded alluvial cobbles, which were probably locally available from the extensive gravel terraces of the area. Possible extra-local pieces comprise two pieces with the distinctive cortex of nodules derived from the Bullhead beds – which outcrops at the junction of the flint-bearing chalk and certain Tertiary deposits in parts of south-east and eastern England (Shepherd 1972, 114). One of these is a simple secondary flake (from erosion gully 14103), but the other is the only formal tool in the entire assemblage, a large end scraper from ditch 24005, and this may represent a finished tool brought to the site from some distance.
- B.4.4 The condition of the flintwork varies, but a large proportion of the assemblage exhibits minor edge damage and rounding consistent with a degree of post-depositional disturbance and some pieces exhibit more severe and extensive edge damage. Recortication ('patination') is very rare, with only one piece (from colluvial depot 13201 in Trench 132) displaying a slight blue sheen.

### Quantification and characterisation

- B.4.5 The most significant assemblages of worked flint were recovered from a series of natural deposits sampled by trenches located in the area of the dry valley in the central/southern part of the site (Trenches 132, 137, 138, 140 and 141). These trenches produced almost 60% of the struck flint from the site. A further minor concentration of flintwork (14 pieces) were derived from colluvial deposits and features sampled in Trench 222 in the extreme north-western part of the site. The flint from these two areas is discussed separately below, followed by a summary of the flintwork from the other trenches.

Context	Sample	Chip	Irregular waste	Flake	Blade	Bladelet	Blade-like flake	End scraper	?Piercer/borer	Single platform core	Minimally worked core	Core/hammerstone	Total worked	Unworked burnt flint count	Unworked burnt flint weight (g)
1704	-													6	56.8
3504	-			1									1		
6404	1			1									1	16	7.7
6404	-		1	1									2	1	23
6406	-													8	45.1
7704	-													25	259.8
8704	-					1	1						2		
12307	-			2									2		
12310	3													8	2.9
12310	-			3									3		
12806	5													12	39.3
13201	-		2	1									3		
13700	-			1									1		
13703	-			1									1		
13803	-									1			1		
14000	-										1		1		
14010	-			7									7		
14017	-		1	7							1		9		
14019	-			1					1			1	3		
14102	-		2	6						2			10	1	8
14104	25	1											1		
14104	-	5		1									6		
14108	-			3									3		
14111	-			1									1		
14112	-				1								1		
16101	-						1						1		
22202	-				1		2						3		
22203	-			4		1	1						6		
22206	-			1									1		
22208	-			4			2						6		
24006	-							1					1		
24006	-			4									4		
		6	6	50	2	2	7	1	1	3	2	1	81	77	442.6

Table 4: Quantification of flint by context

**Dry valley deposits (Trenches 132, 137, 138, 140 and 141)**

B.4.6 With the exception of seven flints derived from the fill of ditch 14004 (Trench 140), all of the flintwork from these trenches derived from natural layers, colluvial deposits and paleochannel fills emplaced along the dry valley. The 48 struck flints from these trenches are overwhelmingly dominated by unretouched removals, alongside a small number of cores and a single retouched tool. Little of this material is strongly chronologically diagnostic, but aside from a single robust blade from natural deposit 14112 in Trench 141, there is a notable absence of Mesolithic/early Neolithic blade-based material, or more generally of systematically produced removals, which would be expected if the assemblage included a significant component of Neolithic material,



and much of this material is suspected to be of later prehistoric date (i.e. after the Early Bronze Age).

- B.4.7 The majority of this flint displayed minor edge damage and rounding consistent with having seen a degree of disturbance, and in many cases this probably reflects its transport within colluvial sediments. One notable exception to this was a group of five chips and a small flake fragment derived from fill 14104 of erosion gully 14203 (Trench 141), which are in fresh condition, and may have represented *in situ* or minimally disturbed material.
- B.4.8 The technological traits of most the unretouched removals indicate the deployment of very simple, unstructured, core reduction strategies, with little evidence for core preparation/maintenance or control over the morphology of removals, and with fairly frequent knapping errors such as hinged distal termination and unresolved bulbs of percussion. This is mirrored in the characteristics of the cores from these deposits, which include three single platform flake cores and several minimally worked or tested cobbles, as well as a minimally worked core that appears to have been used as a hammerstone/percussor (layer 14019, Trench 140). The only potential retouched tool among this material is a thermally shattered nodular piece with a naturally pointed extremity which has been modified through minor edge retouch to fashion a robust piercer/borer.

### **Trench 222**

- B.4.9 The flintwork (16 pieces) recovered from Trench 222 is of markedly different character to that from the trenches which sampled the dry valley deposits to the east. Over half of this (nine pieces) was recovered from colluvial layers 22202 and 22203. This small assemblage is coherent in terms of technology and raw materials and is in relatively fresh condition, and although its recovery from colluvial sediments suggests it has been displaced from its original depositional context, it may not have been transported very far. Made up entirely of unretouched removals, this assemblage includes a high proportion of blade-like flakes and systematically produced flakes. The small assemblage of six flints, including two blade-like flakes, from ditch 22207 is of very similar character to the material from the colluvium, and may represent material incorporated into the ditch fills from these colluvial deposits. A single well-struck flake was also recovered from tree-throw hole 22205. The character of the flintwork from this trench, with a high proportion of blade-like pieces, but lacking very regular prismatic blade-based removals, suggests an earlier Neolithic date for much of this material.

### **Other Trenches**

- B.4.10 The remainder of the trenches produced small quantities of worked and/or burnt flint, much of which is likely to represent residual material caught up in later features. This includes a proportion of Mesolithic/Neolithic blade-based material including pieces from ditch 8703 (Trench 87), alongside more generalised, flake-based, material. As noted above, the fine end scraper made on bullhead flint was recovered from ditch 24006 and is probably of Neolithic date.
- B.4.11 Flint that may not be residual includes the material from a pair of pits in Trench 64 (6403 and 6405): pit 6403 produced a small quantity (7.7g) of unworked burnt flint, two simple hard hammer struck flakes and a piece of irregular waste, whilst pit 6405 produced 45g (eight pieces) of unworked burnt flint. The hard hammer struck flakes are consistent with the later Bronze Age date of the pottery from this feature. Pits

12306 and 12308, recorded in Trench 123, also produced small quantities of flintwork (five unretouched flakes and 2.9g of burnt flint in total) that is consistent in character with the later Bronze Age pottery from these pits, and so could possibly be broadly contemporary.

## **Discussion**

- B.4.12 Given the scale of the evaluation, the flint assemblage is relatively small and the low densities of flintwork from individual contexts and the overall paucity of diagnostic pieces renders interpretation and dating of the material difficult. These caveats aside, the assemblage does provide important evidence for prehistoric activity on the site. The majority of the assemblage was derived from the colluvial sediments and associated deposits in the dry valley in the central/southern part of the site. The flintwork for these contexts is overwhelmingly dominated by simple, expediently produced flake-based material and probably includes a major late prehistoric (Middle Bronze Age or later) component. The smaller, but distinctive, assemblage of flintwork from colluvial sediments and features in Trench 222, meanwhile, includes a high proportion of blade-based material and clearly reflects earlier activity, probably during the earlier Neolithic. This material was generally in fresher condition than the flint from the dry valley and may have been subject to a lesser degree post-depositional disturbance/transport.
- B.4.13 Elsewhere, there were a small number of pits which produced small quantities of worked and/or burnt flint which is likely to be contemporary with these prehistoric features, but there were no substantial assemblages. The rest of the flint from cut features is likely to be residual, reflecting a background of Neolithic and Bronze Age activity across the site.

## B.5 Fired Clay

By Cynthia Poole

### Introduction

B.5.1 A small quantity of fired clay (FC) amounting to 58 fragments weighing 1927g was recovered from Trenches 64, 109, 123, and 155. The assemblage consists of small/large fragments, poorly/well preserved fresh/abraded with a mean fragment weight of 33g. The assemblage consists primarily of substantial parts of two or more late Bronze Age cylindrical perforated blocks from Trench 64. The assemblage has been spot dated and summarised in the table below. The assemblage has been recorded on an Excel spreadsheet (together with the ceramic building material reported separately below) in accordance with guidelines set out by the Archaeological Ceramic Building Materials Group (ACBMG 2007), which whilst not specifically for fired clay provide appropriate guidance. Fabrics were characterised on the basis of macroscopic features supplemented by the use of x20 hand lens for finer constituents.

### Description

B.5.2 Structural material (10 fragments, 131g) was represented by fragments of a hearth floor surface (cx12307). This formed a flat slab over 30mm thick with a roughly moulded uneven upper surface and a worn flat unshaped underside, probably the sheared interface between fired and unfired structure. The upper surface has been partly discoloured white, which may result from the use of the hearth for salt working.

B.5.3 Portable oven or hearth furniture occurred in the form of two substantial parts of cylindrical drum shaped perforated blocks and fragments from one or more similar objects (cx 6404). The two best preserved (sf1 & 2) each represented about half of a block. These measured 93-96mm high and 140mm in diameter and weighed 650 and 508g, suggesting a total weight of about 1kg for each when complete. They were pierced by a central axial cylindrical perforation 17, 18 and 24mm in diameter. Surfaces were smooth and well finished and one or sometimes both ends were burnt black or grey, partly extending over the sides. On one there is part of a very shallow depression with a straight edge in the end surface suggesting another object had been pressed into the end before it had fully hardened suggesting these objects had been fired as part of their use rather than pre-fired.

B.5.4 A thick flat sherd (ctxt 10912) could be a fragment of oven plate but is more likely a piece of briquetage vessel. It is 18-23mm thick possibly thickening to a rim, as this edge together with both surfaces retains a white veneer that may result from salt production. If so, this is probably a fragment of a rectangular evaporation trough.

Context	Spot date	Count	Wt g	Form	Comments
6404	LBA	41	1746	Cylindrical perforated blocks	SF1, SF2 & fragments from at least one other block
10912	Preh-RB?	1	30	Briquetage vessel or plate	Thick flat sherd with cream veneer
12307	Preh-RB?	10	131	Hearth floor	Whitish veneer on surface
15505	Modern?	6	20	Indeterminate	Clay with fragments of wood compressed into it.

Table 5: Summary of fired clay assemblage

## Conclusion

- B.5.5 The fired clay groups were found in diverse areas of the site several hundred metres apart and there is no evidence of any connection between the three groups.
- B.5.6 The perforated blocks occurred in the north-east corner of the site and are typical late Bronze Age artefacts, (commonly regarded as loomweights on account of the perforations). It is worth noting that they occurred in a deposit containing charcoal and burnt flint, which provides support for an interpretation as oven or hearth furniture, utilised as a pedestal or some form of support, rather than that of loomweight which might be expected to produce some evidence of wear from suspension, which was entirely lacking. There is also evidence from a number of late Bronze Age sites for this type of object to be associated with hearths such as at Badwell Ash, Suffolk (Winbolt 1935) or with pottery production at Tinney's Lane, (Tyler and Woodward 2012) and Bestwall Quarry (Woodward 2010), Dorset.
- B.5.7 The hearth floor cannot itself be dated, but is associated with pottery of the later Bronze Age, while the possible briquetage vessel is of uncertain date though probably later than Bronze Age. Both pieces may be indicative of salt working, which is unsurprising in view of the location of the site in close proximity to creeks draining the salt marshes adjacent to the Thames. The quantity of material does not imply intense activity, so an Iron Age date might be considered more likely than Roman: any associated dateable artefacts may more reliably suggest their phase.

## Recommendations

- B.5.8 The assemblage is small but comprises a significant group of material with potential for further research. These should be retained as part of the archive, except for the clay fragments associated with modern wood, which may be discarded if desired at completion of the project.

## B.6 Ceramic building material

By Cynthia Poole

### Introduction

- B.6.1 Ceramic building material (CBM) amounting to 42 fragments weighing 3196g was recovered from Trenches 122, 145, 147, 182-3 and 233. The assemblage is all post-medieval in date, apart from one fragment from context 12205, which is uncertainly attributed as either CBM or fired clay and cannot be dated, though is perhaps more likely to be Roman than later. All is fragmentary with a moderately high mean fragment weight of 76g, but includes a few pieces with a complete width in addition to thickness. Abrasion is generally light or absent.
- B.6.2 The assemblage has been fully recorded on an Excel spreadsheet in accordance with guidelines set out by the Archaeological Ceramic Building Materials Group (ACBMG 2007). Fabrics were characterised on the basis of macroscopic features supplemented by the use of x20 hand lens or binocular microscope at x25 for finer constituents.

### Post-medieval CBM

- B.6.3 The post-medieval CBM comprises flat roof tile, brick, floor tile and chimney pot, nearly all made in a red fine sandy clay fabric. A few of the bricks were made in a coarser sandy fabric. The roof tile was all of flat rectangular form, probably peg tile, though none preserved any peg holes. The roof tile had a fairly regular finish, though several pieces had a slightly lumpy surface. They measured 12-14mm thick. Most are broadly of 16th-18th century date, but two with a neater finish may be 19th century. One of these had a curved edge that had been chipped post firing, possibly to create a bull-nosed shaped tile, usually used for decorative either on roofs or wall cladding.
- B.6.4 The brick was all handmade place bricks with a fairly rough finish including plant impressions on the base of some. Two measured 58mm thick by 100mm wide and 62mm thick by 102mm wide, whilst the remainder measured 53-58mm thick.
- B.6.5 A single floor tile of Flemish type is probably a locally made product rather than an import. It had a neat finish with smooth surfaces and steeply cut bevelled edges. It had a yellow-coloured surface created by an amber glaze over a white slip, with dribbles of the glaze running over the edge. About half the tile survived measuring 27mm thick and 112mm wide. This type of floor tile is of broadly Tudor date and would have been used in conjunction with dark glazed tiles to create a chequerboard pattern.
- B.6.6 A cylindrical chimney pot measuring c 160-170mm in diameter and 20mm thick was hand-thrown and had a smooth outer surface, slightly flattened in places, with an applied decoration. This feature only partly survived but took the form of a series of at least three square (or rectangular) plaques set one on top of another each diminishing in size by c 11mm from the lowest measuring 53mm wide to 42mm to 30mm like a small, stepped pyramid projecting from the pot. The hand-made production method of this pot suggests it is Georgian in date, essentially 18th or at the latest early 19th century.

Context	Spot date	Count	Wt g	Form	Comments
12205	?Roman	1	20	Flat	Single flat surface. Uncertain whether FC or CBM
14504	C19	1	7	Roof flat	
14706	C16-C18	11	89	Brick, Roof flat	
18204	C16-C18	23	2537	Brick, Roof flat, Chimney, Floor	Glazed Flemish type floor tile; Georgian chimney pot
18305	C16-C18	5	502	Brick, Roof flat	
23304	C19	1	41	Roof flat	Possibly chipped post-firing to create bull-nosed tile

Table 6: Summary of CBM assemblage

## Conclusions

- B.6.7 The assemblage is not large but is consistently of 16th-18th century, though including individual items dating exclusively to the beginning or end of this range. These are the Flemish floor tile and the Georgian chimney pot which cannot be contemporary, but occurred together with other more common items of roof tile and brick in context 18204. This group of material represents demolition debris though whether it represents material from a single building or several cannot be determined from the assemblage itself, but if from a single building would suggest it may have originated as early as the late 15th century.

## Recommendations

- B.6.8 The value of the assemblage is in providing dating of the contexts in some cases supplementary to other dating evidence and evidence of structures or activities on or in the vicinity of the site. The material has little additional intrinsic research value, apart from providing evidence of the fabrics in use in the area. In general, the archive record together with a small number of items recommended for retention in the archive record should be sufficient in any wider research encompassing the site or the material. Other pieces may be discarded upon completion of the project prior to archiving.

## B.7 Metals

By Anni Byard

### Introduction

- B.7.1 A total of four metal objects (142.5g) were recovered from three contexts. This total comprised three iron objects (63.5g) and one copper alloy object (79g). Two of the objects could be broadly dated to the medieval and/or post-medieval period while the remaining two are of uncertain dating.
- B.7.2 All the metalwork was scanned during the present assessment and where possible century or broad period dates were assigned. Objects were quantified by type count and weight by context and recorded on a spreadsheet.

### Description

Context	Material	Count	Weight (g)	Object	Date	Description	Notes
3605	Fe	2	23.6	Sheet	?	Two refitting sections of a thin, now distorted iron sheet, broadly rectangular in plan. No obvious holes or attachments.	
18204	Cu alloy	1	79	Uncertain	1270-1650	Sheet metal crudely cut into an uneven oval shape, pointed end has a paperclip rivet. No other signs of fixing or attachment. Slightly dished.	Egan 2005
21100	Fe	1	2.3	Nail	?	Hand forged nail, missing part of head and lower shaft. Uncertain dating.	
21104	Fe	1	37.6	Horseshoe	1100-1350?	Incomplete horseshoe, folded calkin, and probable counter-sunk rectangular nail hole	

Table 7: Description of metalwork by context

### Discussion

- B.7.3 Although the metalwork assemblage is small two objects can be dated to the medieval or post-medieval period. Two objects are of uncertain function and dating due to their state of preservation and homogeneous appearance.
- B.7.4 The oval copper alloy sheet is of uncertain use however the 'paperclip' rivet, or vessel mend, is of a type most seen on vessels of later 15th to late 16th century date (Egan 2005), although there were in use earlier. The crude nature and uniformity of the piece does not indicate a specific use; it could be a trail piece, a vessel lid, or the remains of a spatulate tool, among others.

- B.7.5 The section of horseshoe appears to have a folded calkin and a countersunk rectangular nail hole, both of which would suggest a pre mid-14th century date although a later date cannot be ruled out based on this object alone.
- B.7.6 The remaining two pieces of metalwork comprise two re-fitting sections of a sub-rectangular iron sheet of uncertain function, and an incomplete hand-forged nail of probable medieval or early post-medieval date.

**Recommendations regarding the conservation, discard, and retention of material**

- B.7.7 The copper alloy sheet and the horseshoe fragment should be retained. The iron sheet fragments, and the nail have been recorded and have little potential to inform subsequent works so can be discarded.



### C.1 Environmental Samples

By Richard Palmer

#### Introduction

- C.1.1 Six bulk samples were taken primarily for the retrieval and assessment of Charred Plant Remains (CPR) and the recovery of bones and artefacts.
- C.1.2 A single sample (sample 26) which it was thought might have evidence for anaerobic preservation (waterlogging) was taken from an Auger hole through a palaeochannel sequence.
- C.1.3 Several smaller samples were taken through sediment sequences including colluvium and channel sediments for the recovery of molluscs and for Optically Stimulated Luminescence (OSL) dating, and monoliths were also taken to allow for soil sedimentological analysis. These samples are discussed separately in the geoarchaeology report.
- C.1.4 In addition, two small fragments of uncharred wood were collected by hand from features in Trench 155 and eight small fragments of charcoal were hand collected from a primary ditch fill in Trench 240.

#### Method

- C.1.5 The bulk (CPR) samples were processed in their entirety at Oxford Archaeology using a modified Siraf-type water flotation machine. The flots were collected in a 250µm mesh and residues in a 500µm mesh and dried. The residue fractions were sorted by eye and with the aid of a magnet while the flot material was sorted using a low power (x10) binocular microscope to extract cereal grains and chaff, smaller seeds and other quantifiable remains.
- C.1.6 For the sample with suspected anaerobic preservation (waterlogging), 0.5L of sediment was processed by hand flotation with the flot and residue collected in 250µm meshes and stored wet. Flot material was examined wet under a low power (x10) binocular microscope to identify any quantifiable charred or waterlogged remains.
- C.1.7 For mollusc samples, 2L of sediment was processed by hand flotation to 500µm; the flots and residues were dried in a heated room and retained unsorted for specialist assessment.

#### Results

- C.1.8 Assessment of the bulk (CPR) samples is presented in Table 8.
- C.1.9 **Trench 64.** Sample 1 from undated fill 6404 of pit 6403 produced a mostly charcoal dominated flot. Some of the charcoal is ring porous. Recovered grain is indeterminate and the weed assemblage is limited to grass seeds (Poaceae) and speedwell seeds (*Veronica* sp.). Burnt flint, pottery and fired clay were recovered from the residue.
- C.1.10 **Trench 109.** Sample 4 from fill 10918 of cremation pit cut 10917 produced a large charcoal dominated flot. Due to its size 25% of the flot (150ml) was assessed as this

stage. Apart from the large quantity of charcoal, some of which is ring porous, other recovered material is limited to speedwell seeds, some likely to be modern, and a possible legume. Calcined bone and a 2g sliver of white quartz stone were recovered from the residue.

- C.1.11 **Trench 116.** Sample 2 from fill 11606 of pit 11605 produced a large charcoal dominated flot. Some of the charcoal is ring porous. The useful quantity of identifiable material may be less than indicated due to most of the charcoal being present as thin sheets which may have a plane <2mm.
- C.1.12 **Trench 123.** Sample 3 from fill 12310 of later Bronze Age pit 12308 produced a limited flot. The grain is possibly barley (cf *Hordeum vulgare*) but deformation of the grain adds uncertainty to this identification. Burnt flint was extracted from the residue.
- C.1.13 **Trench 128.** Sample 5 from fill 12806 of posthole 12805 produced a charcoal dominated flot. A significant quantity of roundwood in the form of twig fragments is present; some of the charcoal is ring porous. Burnt stone was recovered from the residue.
- C.1.14 **Trench 141.** Sample 25 from fill 14104 of erosion gully 14103 produced a modest sized charcoal rich flot. This sample was taken specifically to provide an opportunity for radiocarbon dating. The flot lacks obvious roundwood so identification was made of several fragments. Of the five fragments examined one was indeterminate due to mineral encrustation, three are field maple (*Acer campestre*) and one is possibly ash (cf *Fraxinus excelsior*), neither of which are short-lived trees.
- C.1.15 Sample 26 from an Auger hole through fill 14104 of Palaeochannel 14103 produced a 5ml flot. The flot consists of charcoal fragments with about 25 – 50 in the >2mm size range. No roundwood is present and none of the charcoal is readily identifiable. No other material was present in the flot and there is no evidence of anaerobic preservation (waterlogging).
- C.1.16 **Trench 155.** Two small fragments of uncharred wood – heartwood or possibly rootwood - were collected by hand from context 15503 and one fragment from context 15507. These came from small pits that had no evidence of waterlogging within them: sediments are described as light greyish brown sandy clay and silty clay. These are likely to be relatively modern.
- C.1.17 **Trench 240.** Eight fragments of charcoal, probably from a single piece, were recovered by hand from primary ditch fill 24006. The charcoal is diffuse porous heartwood and may be suitable for radiocarbon dating if from a relatively short-lived tree.

## Discussion

- C.1.18 In general, there is some potential for the recovery of charred material across the site but the preservation of this material is variable and the quantity sparse within the sampled features. Most of the recovered grain from these evaluation samples is either indeterminate or has an uncertain identification. The recovered charcoal does, however, offer potential for further work and this may be particularly useful for cremation sample 4. Generally, however, charcoal identification may be hindered by poor preservation or mineral encrustation obscuring the identifying features, as is the case for sample 25.

## Recommendations for retention/dispersal

- C.1.19 The flots and hand collected charcoal warrant retention until all works on site are complete and although it is not expected that further work will be required at this time some flots include sufficient charcoal for further identification and analysis and possibly material suitable for radiocarbon dating.
- C.1.20 The uncharred wood is likely to be relatively modern and does not merit retention in the archive

Sample no.	Context no.	Trench	Feature/Deposit	Date	Sample vol. (L)	Flot vol. (ml)	Charcoal >2mm	Grain	Chaff	Weeds	Molluscs	Other	Notes
1	6404	64	6403	undated	15	40	+++	+	+	+		+	10YR 4/3 sandy silt loam
2	11606	116	11605	undated	12	160	++++						7.5YR 4/6 sandy silt loam
3	12310	123	12308	undated	20	5	++	+					10YR 4/3 sandy clay
4	10918	109	10917	undated	40	600	++++			++		+	10YR 2/2 sandy loam. 150ml assessed
5	12806	128	12805	undated	3	50	++++			+			10YR 3/3 sandy loam
25	14104	141	14103	undated	30	20	+++						10YR 6/4 sand

Key: +=present (up to 5 items), ++=frequent (5-25), +++=common (25-100), ++++=abundant (100+).

Table 8: Assessment of CPR bulk samples

## C.2 Animal Bone

By Rebecca Nicholson

### Introduction

- C.2.1 Thirty one fragments of animal bone weighting 440g in total were recovered by hand on site during the evaluation. The bone was identified using the comparative osteological collection at Oxford Archaeology and has been recorded in a Microsoft Access database. Tooth wear stages follow Grant (1982). Full records are available in the site archive.
- C.2.2 Bone condition was scored on a subjective scale from 1 (as fresh) to 5 (extremely eroded, fragments crumbly and with all or most surfaces missing). Using this scale, the great majority of fragments were scored as condition 5, reflecting the extremely poor preservation of animal bone across the excavated area.

### Description

- C.2.3 The bone is generally in fairly good condition (mostly condition 3), although highly fragmented.
- C.2.4 From Trench 182, post-medieval ditch fill 18204, the identifiable bones included a fragment from a large pig mandible with the second and third molar teeth present and an estimated mandible wear stage of 32 based on Grant (1982) and a fragment of cattle mandible with a worn third molar tooth (Grant's wear stage I) indicative of an elderly animal. Other identifiable bones from this context included fragments from a fused and an unfused distal cattle metapodial.
- C.2.5 From Trench 183, post-medieval pit backfill 18305, a single sheep/goat distal tibia fragment (fused) was the only identifiable fragment.
- C.2.6 From Trench 175, possible pit fill 17503 which is undated, the only bone fragments recovered were two conjoining pieces of a large mammal rib.
- C.2.7 Beyond demonstrating that bone survives fairly well at this site, at least in post-medieval contexts, the assemblage has little further research value.

### Recommendations for retention/dispersal

- C.2.8 The bone is relatively well preserved and although no bones are complete includes several ageable and/or measurable items. It should be retained at least until all works on the site are complete. Post-medieval bone assemblages are often considered less important than earlier material, but this period sees significant livestock improvements and this merits further investigation from well-dated assemblages.

## C.3 Marine Shell

By Rebecca Nicholson

### Introduction

- C.3.1 Eleven valves of European flat oyster (*Ostrea edulis* L.) were recovered by hand from post-medieval ditch fill 18204.

### Description

- C.3.2 The shell is in variable condition and includes both large and small valves from a minimum of five oysters. Two left and five right valves are complete, and one incomplete right valve has a semi-circular perforation just under the hinge, possibly inflicted from a pronged tool when the shellfish were collected. Apart from a few small tunnels on the exterior of one left valve, consistent with the bristleworm *Polydora ciliata* Johnston (as illustrated in Winder 2011) and an example of another valve, or oyster cultch, adhering to one valve, there were no other features of note on the shells.
- C.3.3 Beyond demonstrating that shell survives fairly well at this site, at least in post-medieval contexts, as a very small assemblage it has little further research value at the present time but may be worth adding to any assemblage recovered during a subsequent excavation.

### Recommendations for retention/dispersal

- C.3.4 The shells are mainly complete and potentially measurable and as such are worth retaining in the archive since post-medieval *Ostrea edulis* shells are rarely collected or retained despite the species, once common, being now rare/endangered in UK waters.

## C.4 Human Remains

By Helen Webb

### Introduction and provenance

- C.4.1 A single deposit of cremated bone (10918) was recovered during the archaeological evaluation at land between West Tilbury and East Tilbury. The deposit comprised the lower of two fills within pit 10917, located in the south-western extent of L-shaped evaluation trench 109. The pit was situated on the inside of ring ditch/gully 10913, which was visible from crop mark photographs and partly revealed within Trench 109.
- C.4.2 Pit 10917 was circular, measuring approximately 0.5m in diameter, with steep sides and a total depth of 0.35m. Cremation deposit 10918 was 0.25m thick and comprised a mix of soft, black silty sand and charcoal with occasional small stones and burnt bone fragments. This deposit was overlain by fill 10919, a 0.1m thick layer of soft, mid brown-grey silty sand. The absence of cremated bone in 10919 indicates that this fill acted as a capping layer over the cremation deposit. No truncation or disturbance to the feature was noted.
- C.4.3 Although 10918 was the only cremation deposit recovered during the evaluation, three other pits (10915, 10920, 10921) were revealed in the area immediately surrounding pit 10917, also positioned on the inside of ring ditch 10913. Pit 10915 was excavated but contained no finds, or evidence for a cremation. The other two pits (10920 and 10921) were not excavated, although 10920 was interpreted as a probable cremation pit due to the presence of charcoal and cremated bone at the surface.
- C.4.4 No dating evidence was recovered from cremation deposit 10918 thus it remains undated. However, its close association with the other pits, and their location, adjacent to but respecting the ring ditch 10913, may indicate that all these features are broadly of the same period.

### Methodology

- C.4.5 Deposit 10918 was recovered, processed and analysed in accordance with published guidelines (McKinley 2004). The deposit was subject to whole earth recovery (as sample 4) in the field, before being processed and analysed.
- C.4.6 Processing involved wet sieving the deposit, which sorted it into fractions of >10mm, 10-4mm, 4-2mm and 2-0.5mm. The >10mm and 10-4mm sieve fractions were fully sorted, separating the burnt bone from the extraneous material (e.g. stones). The unsorted 4-2mm fraction was sizeable (c 2.5kg) thus it was not viable to fully sort it. Part of the fraction was fully sorted (yielding 2g of bone) but for the rest, a 100g sample was sorted and the percentage bone weight calculated (2.8g bone from 100g sample = 2.8% bone weight). This percentage was then applied to the total weight of the unsorted fraction to give a more reliable estimated bone weight within it (2.8% of 1922.9g = 53.8g estimated weight). The weights presented in the results below include this estimated weight.
- C.4.7 The smallest fraction size (2-0.5mm) was not sorted but was rapidly scanned for identifiable skeletal remains and artefacts. An estimation of the proportion of bone

present within the 2-0.5mm fraction was made visually and is noted in the results below, although this is not included in the total weights presented.

- C.4.8 All bone was analysed to record colour, weight and maximum fragment size.
- C.4.9 Each sieve fraction was examined for identifiable bone elements and the presence of pyre and/or grave goods. The minimum number of individuals (MNI) present was estimated based on the identification of repeated elements and/or the presence of juvenile and adult bones in the same deposit. Estimations of age and sex were not possible due to the absence of diagnostic features. The bone was examined for evidence of pathology and trauma, as well as non-metric traits.

## Results

- C.4.10 A summary of osteological findings is presented in Table 9.

Context	>10mm	10-4mm	4-2mm	Total weight	Maximum fragment size	Identified elements	MNI/Age/Sex/ Other observations
10918	68.6g	136.1g	55.8g	260.5g	40mm (?humerus shaft)	Cranial vault, maxilla, mandible, tooth roots, rib, vertebral arch, humerus, radius, hand phalanges, innominate, femur, tibia	MNI: 1  AGE: Adolescent (13-17 yrs) /Adult unspecified (>18 yrs)  Sex: ?  Pathology: None

Table 9: Summary of osteological findings

### *Bone Weight*

- C.4.11 At 260.5g the total weight of deposit 10918 falls well below the expected range for both modern (1000-2400g, with an average of 1650g, McKinley 2000a, 269) and archaeologically recovered cremation deposits (600-900g, McKinley 2013, 154). The 2-0.5mm unsorted residues weighed a total of 2218.9g, but the cremated bone content was low, at no more than around 10% (by volume), so this would not have added a significant quantity to the total bone weight.

### *Fragmentation*

- C.4.12 The largest proportion of bone from deposit 10918, representing just over half of the total bone weight (52.2%, 136.1g/260.5g), was from the 10-4mm sieve fraction.
- C.4.13 The largest bone fragment in the deposit was a piece of long bone, probably humeral shaft, measuring 40mm.

### *Skeletal Representation*

- C.4.14 Identified bone fragments made up 22.7% (59.1g/260.5g) of the total bone weight, and all regions of the skeleton were represented within the deposit, thus there was no evidence for deliberate selection/exclusion of body parts for interment.
- C.4.15 Amongst the most frequently identified elements was the cranial vault, fragments of which are easily identifiable even amongst the smaller fractions. Other elements of the skull included small fragments of mandible and maxilla, and three tooth root fragments, although the actual teeth could not be identified. A small number of rib and vertebral arch fragments represented the axial skeleton, whilst humerus and radius shaft fragments, along with a number of hand phalanges, made up the identified upper limb bones. The lower limbs were identified by a few small innominate (probably ilium) fragments, as well as femur and tibia shaft fragments.
- C.4.16 As with many archaeological cremation deposits, a large majority of the total bone weight (77.3%, 201.4g/260.5g) was made up of unidentified bone and, as expected, over a third of this (34.0%, 68.5g/201.4g) comprised unidentified long bone fragments.

### *Colour of the cremated bone*

- C.4.17 The colour of cremated bone reflects the degree of oxidation and is therefore an indication of the efficiency of the cremation, in terms of the quantity of fuel used to build the pyre, the temperature attained in various parts of the pyre, and the length of time over which the cremation was undertaken (McKinley 2004, 11). Colour may range from brown/orange (unburnt), to black (charred: c 300°C), through hues of blue and grey (incompletely oxidised, up to c 600°C) to white (fully oxidised, >600°C) (ibid.).
- C.4.18 The burnt bone from deposit 10918 was white, although most fragments exhibited blackish surface staining, resulting from the charcoal-rich matrix within which the bone had been buried.

### *Demography*

- C.4.19 In the absence of any obvious repeated elements, the minimum number of individuals (MNI) represented was one.
- C.4.20 As noted in Methods above, it was not possible to estimate age or sex due to the absence of any diagnostic features, however, it can be stated that the remains represent an adolescent (13-17 years) or adult (unspecified, >18 years), based on the general thickness, size and morphology of identified fragments.

### *Pathology and non-metric traits*

- C.4.21 No pathology, trauma or non-metric traits were observed.

### *Pyre/grave goods*

- C.4.22 No pyre or grave goods were observed within the burnt bone deposits. No staining or residue, indicative of pyre/grave goods, were observed.



## Discussion

- C.4.23 The single cremation deposit recovered from Trench 109 comprised the remains of a single individual (MNI 1), most likely an older juvenile (adolescent) or adult. No other demographic details could be ascertained.
- C.4.24 The deposit was small, weighing just 260.5g, which is well below the expected range (600-900g) for archaeologically recovered adult cremation burials (McKinley 2013, 154). There was no evidence for disturbance or truncation of the remains and, furthermore, the deposit was capped by 10919, thus it seems likely that the total weight of bone is in keeping with that originally deposited. Low bone weights are a common finding in archaeological cremation deposits, even from untruncated features such as this, and these may be defined as *cremation related deposits* rather than formal cremation burials. Such deposits might represent cenotaph burials, where only a token amount of bone was deposited (McKinley 2000b, 42-3), or redeposited pyre debris, which generally comprises a mixture of bone fragments and fuel waste (McKinley 2004, 10). Indeed, frequent charcoal was noted during the excavation of 10918, and during analysis it was noted that the bones exhibited black surface staining from contact with the charcoal-rich matrix. It is therefore suggested that 10918 was a pyre debris deposit, rather than a formal cremation burial. Deposits of pyre debris are frequently encountered archaeologically and are not specific to one time period (McKinley 2000b, 41).
- C.4.25 Overall, the bones were white in colour (fully oxidised). This indicates that the corpse would have been placed on the pyre in such a way as to maintain a consistent high temperature and oxygen supply (McKinley 2013, 158), enabling a temperature in excess of 600°C (McKinley 2004, 11). A high proportion of fully oxidised bone is a common observation in archaeological cremation burials (McKinley 2006, 84).
- C.4.26 All osteological information has been obtained from deposit 10918, thus no further work is recommended. However, it is recommended that the remains are retained for direct consideration in relation to any future deposits which may be recovered, given the potential for further works in the surrounding area. Given that the deposit is undated, it is recommended that a sample of bone is submitted for radiocarbon dating. There are several suitable bone fragments for sampling within the deposit.
- C.4.27 The assemblage is currently held at Oxford Archaeology under Ministry of Justice burial licence 19-0317. This licence is valid until 22nd December 2024, by which time the remains must have been reburied. In the event that the remains are not ready for reburial by this time the licence should be deferred by application to the Ministry of Justice. Deferring the licence so that the human bone can be deposited with a local museum is recommended, considering the future research potential.

## C.5 Geoarchaeological Summary

By Christoff Heistermann and Liz Stafford

### Introduction

- C.5.1 The geoarchaeological component of the evaluation comprised the targeted recording and sampling of the deep sedimentary sequences exposed in the trenches to supplement standard archaeological recording. As outlined in the WSI, one of the principal objectives of the evaluation trenching was to investigate the archaeological potential of the Holocene colluvial sequences contained within dry valleys, to identify whether features and/or artefact scatters are preserved within or beneath the colluvium and if any in situ buried soils/land surfaces can be detected. The evaluation also intended to provide preliminary information on the nature, depth, and distribution of the Holocene colluvium in advance of a second phase of purposive test-pitting intended to evaluate the underlying Pleistocene/Palaeolithic potential of the sedimentary sequences.
- C.5.2 The area under investigation (Land Parcel 9) has been previously reviewed as part of the scheme-wide Palaeolithic and Quaternary Deposit Model (PQDM) (Wenban-Smith and Bates 2020). It falls within zone PQ-12a (Shearwater Avenue), characterised geologically by Thanet Sand bedrock overlain by Taplow/Mucking Gravel with Head contained within dry valleys. The preliminary Palaeolithic potential was assessed as being low to moderate. The site is located on the north bank of the Thames on sloping ground overlooking the floodplain. Ground elevations range from approximately 22m to 4m OD with the highest to the north and north-west in the vicinity of Muckingford Road. Two dry valleys filled with Head are located within the site. One linear valley in the north-west crossing Muckingford Road, is aligned NNE-SSW in the vicinity of Trenches 11-14. The second irregular lobe shaped valley originates in the central area in the vicinity of Trench 132 and is connected to a wider shallow basin, the base of which lies beyond the site limits but is occupied by a dammed canalised stream. Alluvium is mapped in the vicinity of this stream at the point where it drains onto the Thames floodplain below.

### Method

- C.5.3 The trenches were initially excavated to a maximum of 1m BGL, less than that where clear Pleistocene deposits or bedrock were exposed, or where archaeological scatters and features were detected. For most of the site topsoil directly overlay terrace gravel. A selection of seven trenches (ten sections) in the vicinity of the dry valley in the central part of the site were excavated to a maximum of 1.5-2m BGL to investigate colluvial sequences. Augering was carried out in the base of the trenches at six locations (Table 10).

Trench	Section	Easting	Northing	Total depth (m)	Augered
132	13200	566834.8	178232.7	3.59	Yes
	13201	566832.3	178215.2	2.95	Yes
134	13400	566861.2	178192.8	5.00	Yes
	13401	566861.1	178197.9	1.63	
135	13500	566886.2	178164.2	4.08	Yes
137	13701	566950.9	178140.6	4.16	Yes
138	13800	566971.8	178123.6	1.80	

Trench	Section	Easting	Northing	Total depth (m)	Augered
140	14001	567000.8	178081.3	1.55	
141	14101	567008	178059.9	1.55	
	14102	567009	178064.2	3.70	Yes

Table 10: Summary of geoarchaeological sections

- C.5.4 Due to the large number of trenches and programme restrictions, it was not possible to carry out deeper excavations in all trenches, and so a sample of the deeper trenches were chosen with the aim of providing a representative selection. Where buried soils were identified, the full length of the trench was deepened to examine the surface for archaeological remains, rather than one or more sondages to record only their sedimentary characteristics/geoarchaeological potential.
- C.5.5 The recording of the sediments comprised the detailed geoarchaeological logging of one of more 1-2m wide sections in each of the trenches, the number depending on the complexity of the sequences. Each section was allocated a section number and located relative to the National Grid and Ordnance Datum. The sediment sequences were recorded from ground surface on a geoarchaeological log proforma with each layer allocated a unique context number on sequences containing archaeological finds/features or where samples were taken. Preliminary interpretations of associated depositional processes were also recorded on the logs.
- C.5.6 Sediment recording followed Historic England guidelines (2015) and following Jones et al. (1999) typically included a description of texture, compaction, colour, clast size and abundance, bedding structures and other inclusions (eg. charcoal), post-depositional features (eg. rooting, mottling, mineralisation), and the nature of sediment contacts (eg abrupt, diffuse, irregular).
- C.5.7 Sampling of the sediment sequences was carried out in accordance with Historic England guidelines (2011) and was targeted in Trench 141 where a gully-like feature was recorded. The sampling included 2L incremental samples (mainly to assess mollusc preservation) and monoliths. Priority was given to any artefact rich contexts where larger 10-40L bulk samples were also recovered for assessment of charred plant remains (CPR) and recovery of micro-artefacts (see Palmer this report). Along with the monoliths, OSL samples were also taken from these sequences to allow for further analysis and dating should this be required. Where sampling was carried out, the log proforma was accompanied by a measured section drawing on permatrace marking the position of the samples.
- C.5.8 Following the completion of fieldwork, the lithological information from the logs was entered into geological modelling software (Rockworks17) to allow the identification and broad correlation of a series of sediment facies. This enabled the creation of a digital transect illustrating the key deep trench profiles across the main valley sequence and the location of corresponding samples (Figs 15 and 26).

## Results

- C.5.9 Overall, several broad sediment facies were recorded across the valley sequence summarised as follows:
- **Topsoil** - modern sandy ploughsoils

- **Colluvium** – Later prehistoric and historic ploughwash. Soils eroded from upslope. Mid grey brown sandy silts frequently crudely bedded with variable often poorly sorted clast content and reworked artefactual material. A product of rill and gully erosion and sheetwash.
- **Fine-grained slope deposits** – Sheetwash (?), pale yellowish brown sands and silts, generally stone free or with limited clast content, gravel stringers. Brickearth type deposits potentially of both Pleistocene, late Glacial-early Holocene date derived from erosion of loess and/or Thanet Sand.
- **Gravelly Head deposits** – variable cold climate Pleistocene solifluction deposits dominated by poorly sorted flint gravel.
- **Sand and gravel** – Pleistocene fluvial terrace gravel.
- **Thanet Sand**

C.5.10 Where possible it is useful to make the distinction between later Holocene colluvium (hill wash/ploughwash) and Pleistocene - early Holocene slope deposits, which together are grouped as 'Head' by the BGS and during geotechnical investigations. However, it is recognised that this is not always possible in the field, particularly with earlier Holocene prehistoric sequences of deposits that derive from reworked Thanet Sand, or those that present as reddish brown argillic horizons (reworked tertiaries? solution residue? or remnant Bt horizons). Key archaeological horizons may occur at the interface between the base of the Holocene colluvium and the earlier slope deposits, where artefact scatters (LUP, Mesolithic/Neolithic, Bronze Age) may be preserved, sometimes in association with buried soils. Buried soils (and artefact scatters) may also occur within the Holocene colluvium.

C.5.11 Sampling was carried out on two sequences detailed in Table 11 below. The monoliths and OSL samples have been retained should further work be required. All ten series samples were processed but no mollusc shell was found in any of the flots, so will not be commented upon further.

Trench	Section	Bulk	Monolith	OSL	Series	Total
141	14101		1	2	2	5
141	14102	1	3	3	8	15
<b>Total</b>		<b>1</b>	<b>4</b>	<b>5</b>	<b>10</b>	<b>20</b>

Table 11: Summary of sampled colluvial sequences

C.5.12 A single transect NW-SE has been produced to illustrate the nature of sequences recorded (Fig. 26), Thanet sand was only positively identified in one location, in the auger hole in Trench 137 at a depth of 4.01m BGL (2.84m OD).

#### *Terrace Gravel*

C.5.13 The basal deposit in most of the auger holes comprised fluvial sand and gravel, probably a remnant of the Terrace Gravel, the surface of which occurred at 3.39m BGL (6.33m OD) in the northern end of Trench 132 (Section 13200). The elevation was higher in the southern end of the trench (Section 13201) at 2.92m BGL (7.23m OD), being located on the periphery of the dry valley. To the south-east in Trenches 134 (Section 13400) and 135 (Section 13500) the elevation dropped to 4.35m BGL (5.16m OD) and 4.03 (4.95m OD) respectively. A marked drop was noted in Trench 137 at 3.76m (3.09mOD) where the sand and gravel directly overlay Thanet Sand at 0.25m in thickness.

### *Head Deposits*

- C.5.14 To the south-east of Trench 137 no Terrace Gravel was encountered during augering in Trench 141 (Fig. 24, Section 14102). The section was augered to a depth of 3.55m BGL (0.28m OD). At 2.75m BGL (1.08m OD) the auger encountered a brown clayey silt grading into a stiff light grey silty clay, which included occasional gravel clasts (10%) at 2.80m and 3.45m BGL, below 3.45m the unit displayed yellowish brown mottling and Fe concretions. This has been interpreted as a possible Head deposit.
- C.5.15 Gravelly Head deposits were also present up-valley overlying the Terrace Gravel in Trenches 132, 134 and 135, between 0.15m and 0.61m in thickness, the surface of which was recorded at 2.31m BGL (7.41m OD) in Trench 132 (Section 13201), dropping to the south-west to 3.56m BGL (5.42m OD) in Trench 135 (Section 13500). These Gravelly Head deposits, described as bedded in Trench 132, generally comprised light brown sandy silt and silt, locally clayey, with 25-50% poorly sorted clasts of angular and sub-angular to sub-rounded flint (<60mm), with intermittent lenses of fine to coarse sand (2-30mm).

### *Fine-grained slope deposits*

- C.5.16 Overlying the terrace gravel and present in all of the trenches were thick deposits of brickearth-type deposits. These deposits appeared as soft to firm fine-grained pale yellowish brown, olive brown and and brown silt, locally sandy and/or clayey and are interpreted as slope deposits. The deposits were generally clast-free, although occasional thin ephemeral zones of peagrit were noted (stringers?), and fine calcareous nodules, along with zones of Fe mineralisation, and finely stratified lenses of pale white silt (1-3mm) (Plates 11, 12, 13, 14, 15).
- C.5.17 Where the augering reached Gravelly Head or Terrace Gravel, these fine-grained deposits achieved a thickness of c 2-3m. The thickest deposits were recorded in Trench 134 (Section 13400) at 3.2m. In Trench 141 (Section 14102) the deposits were truncated to a depth of 2.4m (1.43m OD) by feature 14103 (Plate 16; Fig. 24, Section 14100), appearing in the auger at a thickness of 0.35m.
- C.5.18 For the most part these deposits are likely to date to the Pleistocene, frequently exhibiting post-depositional structural deformation, leaching and mineralisation characteristic of cold climate ground processes. However, it is possible the very upper parts of the sequence are of Holocene date. Single pieces of worked flint were identified in Trench 141 (layers 14111 and 14112). In Layer 14112 the flint comprised a robust blade of possible Neolithic date (Plate 16; Fig. 24, Section 14100). The upper levels of the deposits generally displayed evidence of bioturbation with worm burrows, and the upper contact with the overlying colluvium an ephemeral weathered (Bt) horizon (eg. Trench 132, layer 13202/03; Trench 134, layer 13403; Trench 137, layer 13707/08; Trench 138, layer 13804/02).

### *Feature 14103*

- C.5.19 Feature 14103, Section 14100, was variously described as a gully, ditch or small palaeochannel (Plate 16; Fig. 24, Section 14100) which truncated layer 14112. The fills also contained worked flint which was most abundant in fill 14104 and was found to be in fresh condition, and may represent in situ or minimally disturbed material (Billington, this report). Bulk samples <25> and <26> from fill 14104 produced a charcoal rich flot that may be suitable for radiocarbon dating (see Palmer, this report).

The assessment of the flots did not provide any evidence for waterlogged preservation. The fills of the feature were described as light greyish brown sandy silt and silty sand, with frequent Fe mottling (25%), and common lenses (diffuse 30mm) of olive grey clay silt in layer 14105. A series of monoliths and OSL samples were recovered from two profiles (Sections 14101 and 14102, Fig. 24; Plate 17).

### *Colluvium*

- C.5.20 Colluvial ploughwash deposits of probable later prehistoric and historic date were present in all of the trenches, reaching a maximum thickness of 1.11m in Trench 137. For the most part this facies is described as a yellowish brown to brown sandy silt, with common to frequent (10-25%) angular to subrounded flint pebbles and common worm burrows. The ploughwash varies very little across the transect. Worked flint (probably reworked) occurred sporadically in Trenches 132, 137, 138, 140 and 141. Colluvial layer 14102 sealed feature 14103.
- C.5.21 Ditch 14004, in Trench 140 appeared to be stratified between colluvial layers 14017 and 14018 (Plate 18; Fig. 25, Section 14001). The ditch truncated layer 14017 (=14019) which was a thin layer of grey silt with Fe mottling. Both layer 14017 and fill 14010 contained frequent worked flint of probable later prehistoric date (later Bronze Age).

### **Discussion and potential**

- C.5.22 In summary, geoarchaeological investigations carried out during the evaluation of Land Parcel 9 focused on seven deep trenches excavated in a broad NE-SW transect across a dry valley located in the central part of the site. The trenches were excavated to a depth of c 1.5-2.0m BGL, after which targeted hand-augering was carried out to attempt to record the deeper sediments. Only one location in Trench 137 positively identified Thanet Sand bedrock. The basal deposits invariably recorded Pleistocene Terrace Gravel, overlain by gravelly Head and thick sequences of fine-grained brickearth type deposits, probably derived from reworked Thanet Sand and/or loess. For the most part, these latter deposits are likely to be of Pleistocene age, although the upper parts of the sequences may be of early-mid Holocene age and displayed evidence of bioturbation, particularly worm burrows and (truncated) weathered (Bt) horizons. In Trench 141 worked flint of possible Neolithic date was recovered from the upper part of these fine-grained deposits (Layer 14112) associated with feature 14103. This feature also contained worked flint in a good state of preservation suggesting minimal reworking (layer 14104).
- C.5.23 However, apart from this, little evidence of activity was recorded beneath the colluvial ploughwash. The ploughwash was recorded in most trenches and is likely to be of later prehistoric and historic age. Worked flint (reworked) of probable later prehistoric date was recorded sporadically, but was a little more frequent in Trenches 140 and 141 (layers 14017 and 14102). The only feature stratified within the colluvial sequence was ditch 14004, recorded in Trench 140, which truncated layer 14017. This contained worked flint of later prehistoric date.
- C.5.24 In terms of palaeo-environmental potential, the sediments encountered in the dry valley were largely oxidised, with no evidence of waterlogging and offer no real potential for analysis eg. plant remains or pollen. Of the incremental samples recovered from Trench 141, mollusc shell was found to be entirely absent. The bulk samples recovered from feature 14103, however, did contain small charcoal

assemblages that could be suitable for radiocarbon dating. In addition, OSL samples and monoliths recovered from the sequence of sediments in Trench 141, including layer 14112 that also contained a possible Neolithic blade, have been retained should further work be required.

## Appendix D      References

---

- ACBMG, 2007 Ceramic building material, minimum standards for recovery, curation, analysis and publication
- Bamford, H, 1985 *Briar Hill: Excavation 1974–1978*, Northampton Development Corporation, Northampton
- Bannister, K, 1961 East Tilbury Barrow - 1960. *Panorama* **6**, 19-27
- Bannister, K, 1962 East Tilbury Barrow. *Panorama* **7**, 268-288
- Biddulph, E, Compton, J, and Martin, T S, 2015 The late Iron Age and Roman pottery, in M. Atkinson and S. J. Preston, Heybridge: A late Iron Age and Roman settlement: Excavations at Elms Farm 1993-5, *Internet Archaeology* **40**, <http://dx.doi.org/10.11141/ia.40.1.biddulph1>
- Bigley, R, 1982 The Coal Road – A highway in decline, *Panorama*, Thurrock Local History Society **25**, Spring 1982
- Butler, C. 2005 *Prehistoric Flintwork*, Tempus, Stroud
- Chartered Institute for Archaeologists (CIfAa), 2014 Standard and Guidance for Archaeological Evaluation. Retrieved from <http://archaeologists.net/sites/default/files/node-files/IfASG-Evaluation.pdf>
- Chartered Institute for Archaeologists (CIfAb), 2014 Standard and Guidance for the Creation, Compilation, Transfer and Deposition of Archaeological Archives
- Cotter, J P, 2000 *Post-Roman Pottery from Excavations in Colchester 1971-1985*, Colchester Archaeological Report **7**
- Drury, P. J. and Rodwell, W. J. (1973). Excavations at Gun Hill, West Tilbury, *Essex Archaeology & History* **5**, 48-112
- Egan, G, 2005 *Material culture in London in an age of transition. Tudor and Stuart period finds c 1450-c 1700 from excavations at riverside sites in Southwark, London*, Museum of London Archaeology Service, Monograph **19**
- Essex County Council, Historic Environment Branch, 2010 The Greater Thames Estuary Historic Environment Research Framework: Part 1 Update and Revision of the Archaeological Research Framework for the Archaeological Research Framework for the Greater Thames Estuary 1999. London: Greater Thames Estuary Archaeological Steering Committee
- Evans, C, Appleby, G and Lucy, S, with Appleby, J and Brudenell, M, 2016 *Lives in the Land. Mucking Excavations by Margret and Tom Jones, 1965-1978: Prehistoric, Context and Summary*, Oxbow Books
- Going, C J, 1987 *The Mansio and other sites in the south-eastern sector of the Caesaromagus: The Roman pottery*, CBA Res Rep **62**, London



- Grant, A, 1982 The Use of Tooth Wear as a Guide to the Age of Domestic Ungulates, pp 91-108 in: B Wilson, C Grigson and S Payne (eds.) *Ageing and Sexing Animal Bones from Archaeological Sites*, Brit Arch Rep, British Series **109**, Oxford
- Healy, F, 1988 *The Anglo-Saxon Cemetery at Spong Hill, North Elmham. Part VI: Occupation in the seventh to second millennia BC*, East Anglian Archaeology **39**
- Highways England, 2018 Lower Thames Crossing: A Scheme Wide Specification for Archaeological Trial Trenching: unpublished document HE540039-CJV-GEN-GEN-SPE-HER-00001draft, Revision 1.05
- Historic England, 2015 *Geoarchaeology: Using earth sciences approach to understand the archaeological record*, Swindon
- Historic England, 2015 Management of Research Projects in the Historic Environment: The MoRPHE Project Managers' Guide. Swindon: Centre for Archaeology Guidelines
- Inizan, M-L, Reduron-Ballinger, M, Roche, H and Tixier, J, 1999 Technology and Typology of Knapped Stone (Translated by J. Feblot-Augustines). *Cercle de Recherches et d'Etudes Préhistoriques* Tome **5**. Nanterre
- Jones, A P, Tucker, M E, and Hart, J K, 1999 Guidelines and Recommendations, in *The description and analysis of Quaternary stratigraphic field sections*, Technical Guide No. **7**. (eds A P Jones, M E Tucker and J K Hart), Quaternary Research Association: London, 27-76
- Kemble, J, 2013 *The Place –Names of West Tilbury, Essex Place-names Project*, Essex Society for Archaeology & History, 2013 (e-book)
- Kemble, J, 2014 *The Place –Names of East Tilbury. Essex Place-names Project*, Essex Society for Archaeology & History
- McKinley, J I, 2000a Cremation burials, in B Barber and D Bowsher, *The Eastern Cemetery of Roman London. Excavations 1983-1990*, MoLAS Monograph **4**, 264-277
- McKinley, J I, 2000b Phoenix rising; aspects of cremation in Roman Britain, in J Pearce, M Millett and M Struck (eds), *Burial, Society and Context in the Roman World*, 38-44, Oxford, Oxbow Books
- McKinley, J I, 2004 Compiling a skeletal inventory: cremated human bone, in M Brickley and J I McKinley (eds), *Guidelines to the Standards for Recording Human Remains*, 9-13, IFA Paper No. **7**, BABAO and IFA: Southampton and Reading
- McKinley, J I, 2006 Cremation...the cheap option?, in C Knusel and R Gowland (eds), *The Social Archaeology of Funerary Remains*, 81-8, Oxford, Oxbow Books

- McKinley, J I, 2013 Cremation: excavation and analysis, in S Tarlow and L Nilsson Stutz (eds) *The Oxford Handbook of the Archaeology of Death and Burial*, 147-72, Oxford, Oxford University Press
- MoLA, 2014 London medieval and post-medieval pottery codes, Museum of London Archaeology, <http://www.mola.org.uk/medieval-and-post-medieval-pottery-codes> (Accessed 11 Jan 2019)
- Oxford Archaeology, 2005 East Tilbury and Linford, Essex, Archaeological Evaluation Report, unpublished report
- Oxford Archaeology, 2016 Neolithic, Bronze Age and Modern activity at Bata Fields, East Tilbury, Essex, Excavation Report, unpublished report
- Oxford Archaeology, 2019 Lower Thames Crossing Scheme-wide Written Scheme of Investigation for Trial Trenching north of the River Thames
- Oxford Archaeology, 2020 Detailed Written Scheme of Investigation for Trial Trenching of Land Parcels 6 (south), 8 (south), 9, 10 and 36. WSI I
- Palmer, J J, 2019 *Open Domesday*. <https://opendomesday.org/place/>: University of Hull
- Place Services, 2019 Lower Thames Crossing Aerial Investigation and Mapping Report, Essex County Council
- Schofield, T, 2010 Mill House Farm, Chadwell St Mary, Essex, Archaeological Evaluation, Archaeological Solutions Ltd, Unpublished client report
- Shepherd, W, 1972 *Flint: its origin, properties and uses*. London, Faber and Faber
- Sheridan, J A, 2008 Towards a fuller, more nuanced narrative of Chalcolithic and Early Bronze Age Britain 2500-1500 BC, *Bronze Age Review* **1**, pp. 57-78
- Smoothy, M D, 1993 Horndon-Coalhouse Fort (Tilbury) Gas pipeline, Archaeological report, Linford H-CHF93, Unpublished client report
- Tomber, R, and Dore, J, 1998 *The National Roman fabric reference collection: a handbook*, MoLAS Monograph **2**, London
- Tyler, K and Woodward, A, 2012 Fired Clay in J Best and A Woodward, Late Bronze Age Pottery Production: Evidence from a 12th-11th century BC Settlement at Tinney's Lane, Sherborne, Dorset, *Proc. Preh. Soc.* Vol.**78**, 207-262
- Winbolt, 1935 Notes: Loom-weights from a kiln *Antiq. J.* **15**, 474-5, plate74
- Wenban-Smith, F and Bates, M, 2020 Palaeolithic and Quaternary Deposit Model (PQDM) for the Lower Thames Crossing
- Woodward, A, 2010 'Fired clay' in Ladle, L, and Woodward, A, *Excavations at Bestwall Quarry, Wareham 1992-2005 Volume 1: The Prehistoric Landscape*, Dorset Natural History and Archaeological Society Monographs, pp289-299

## Appendix E      Abbreviations and Glossary

---

**ADS** Archaeology Data Service. Digital archaeological archive

**CDM** Construction Design Manual. Health and safety guidance for the construction industry

**CPD** Continuing Professional Development

**CIfA** Chartered Institute for Archaeologists

**DBA** Desk Based Assessment. Detailed assessment of archaeology and other aspects of the historic environment

**DCO** Development Consent Order

**EIA** Environmental Impact Assessment. Detailed study of environmental impacts as directed under the Town and Country Planning (Environmental Impact Assessment) Regulations 2017 following on from EU Directive EIA Directive (85/337/EEC)

**ES** Environmental Statement. The principal environmental report detailing environmental impacts within an EIA

**GPS** Global Positioning System

**HER** Historic Environment Record

**LTC** Lower Thames Crossing

**MCIfA** Member of the Chartered Institute for Archaeologists

**MoRPHE** Management of Research Projects in the Historic Environment

**NMP** National Mapping Programme. A study of aerial photographs and digitisation of resulting data into GIS. Originally funded by Historic England

**OASIS** Online Access to the Index of archaeological investigations.  
The OASIS project brings together a number of strategic partners: the Archaeology Data Service, Historic England, Historic Environment Scotland, and the Royal Commission on the Ancient and Historical Monuments of Wales under the umbrella of the University of York

**OCN** Old County Number. Historic England's reference for material that is not readily-available online and may represent historic archaeological work that consists of paper archives or has yet to be formally reported on

**PINS** Planning Inspectorate

**RAMS** Risk Assessment Method Statement

**SMC** Scheduled monument consent

**TDR** Trusted Digital Repository

**UKIC** United Kingdom Institute for Conservation

**WSI** Written Project of Investigation. A detailed method statement for archaeological work

**WSL** – Western Southern Link  
The Western Southern Link (WSL) is an alternative for Short List Routes 2, 3 and 4 to the south of the River Thames.

## Appendix F Site Summary

---

<b>Site name:</b>	Lower Thames Crossing Land Parcels 6, 8, 9, 10 and 36 Land between West and East Tilbury, Essex
<b>Site code:</b>	LTC6T20
<b>Grid Reference</b>	NGR 566860 178384
<b>Type:</b>	Evaluation
<b>Date and duration:</b>	20 August – 7 October 2020
<b>Area of Site:</b>	82.72ha

### Location of archive:

The archive from LTC6T20 (Land Parcels 6, 8, 9, 10 and 36) will form part of the overall trial trenching scheme archive. This will be deposited in a repository consistent with the standards required by the Museums and Galleries Commission following completion of the archaeological phase of this project. This may either be with the local receiving museum in Thurrock or, if no such repositories are available, with a repository for the whole project designated by LTC. LTC retain the overall responsibility for the successful deposition of the project archive.

Currently, the archive is held at Oxford Archaeology's head office, Janus House, Osney Mead, Oxford, Oxfordshire, OX2 0ES. Oxford Archaeology will store the archive for LTC for a maximum period of 2 years following the completion of the project. If the storage of the archive at OA's office extends past this period, an extension to the storage period and final deposition timetable will be reviewed by OA and LTC and agreed with the major stakeholders.

### Summary of Results:

Oxford Cotswold Archaeology was commissioned by Balfour Beatty to undertake a trial trench evaluation of land parcels 6, 8, 9, 10 and 36 covered by WSI I of the Lower Thames Crossing Pre-Enabling Works. These land parcels are located between West Tilbury and East Tilbury within the county of Essex and Thurrock unitary authority (NGR 566860 178384). A total of 230 trenches were dug and recorded between 20th August and 7th October 2020.

The earliest archaeological evidence recorded during the evaluation was represented by a small assemblage of residual Mesolithic/Neolithic blade-based flints retrieved from a small undated ditch in the northern part of the site. A ditch containing a small amount of early Neolithic pottery and flints including a flint scraper was revealed at the north-eastern edge of the site, and colluvium at the north-west edge contained fresh Neolithic flintwork and pottery potentially of early Neolithic date.

Evidence of later prehistoric activity was scattered right across the site, but with a possible focus in the centre. Four circular pits, one containing middle Bronze Age pottery, the others late Bronze Age pottery, in association with hearths, oven furniture and charred plant remains, were found in the northern and central parts of the site, and later Bronze Age struck flint in colluvium and an erosion gully in a dry valley. Small amounts of pottery of later Bronze Age or early Iron Age date came from several other pits and small ditches in the northern and eastern parts of the site.

The centre of the site contained cropmarks of a sub-rectangular enclosure with an associated field system, and a circular smaller enclosure adjacent on the west. No finds

came from the curving ditch of the circular cropmark, but two unurned cremation pits were found within the area enclosed by the curvilinear ditch, and although not dated, may well indicate a small Bronze Age barrow or flat cemetery. To the east, and within the sub-rectangular enclosure, a later Bronze Age or early Iron Age complete ceramic vessel had been placed upright in a pit, and may represent associated activities. The only finds from the sub-rectangular enclosure ditches were a couple of small sherds, one of late Iron Age/early Roman or 10-11th century date, the other of early Medieval date, in the top of one ditch. The sub-rectangular enclosure is not therefore securely dated, and no finds were recovered from the associated field system.

Two ditches located in the western and central parts of the site contained small, abraded quantities of late Iron Age/Roman pottery indicated very limited Roman activity. Two isolated medieval pits, one containing pottery, the other a horseshoe, were found in the southern and eastern parts of the site.

A boundary ditch and two very large pits, probably indicating quarries, all containing Tudor pottery and 16th -18th century CBM, were revealed at the very south end of the site adjacent to the hamlet of Low Street. Several ditches that corresponded to historic mapping were also recorded.

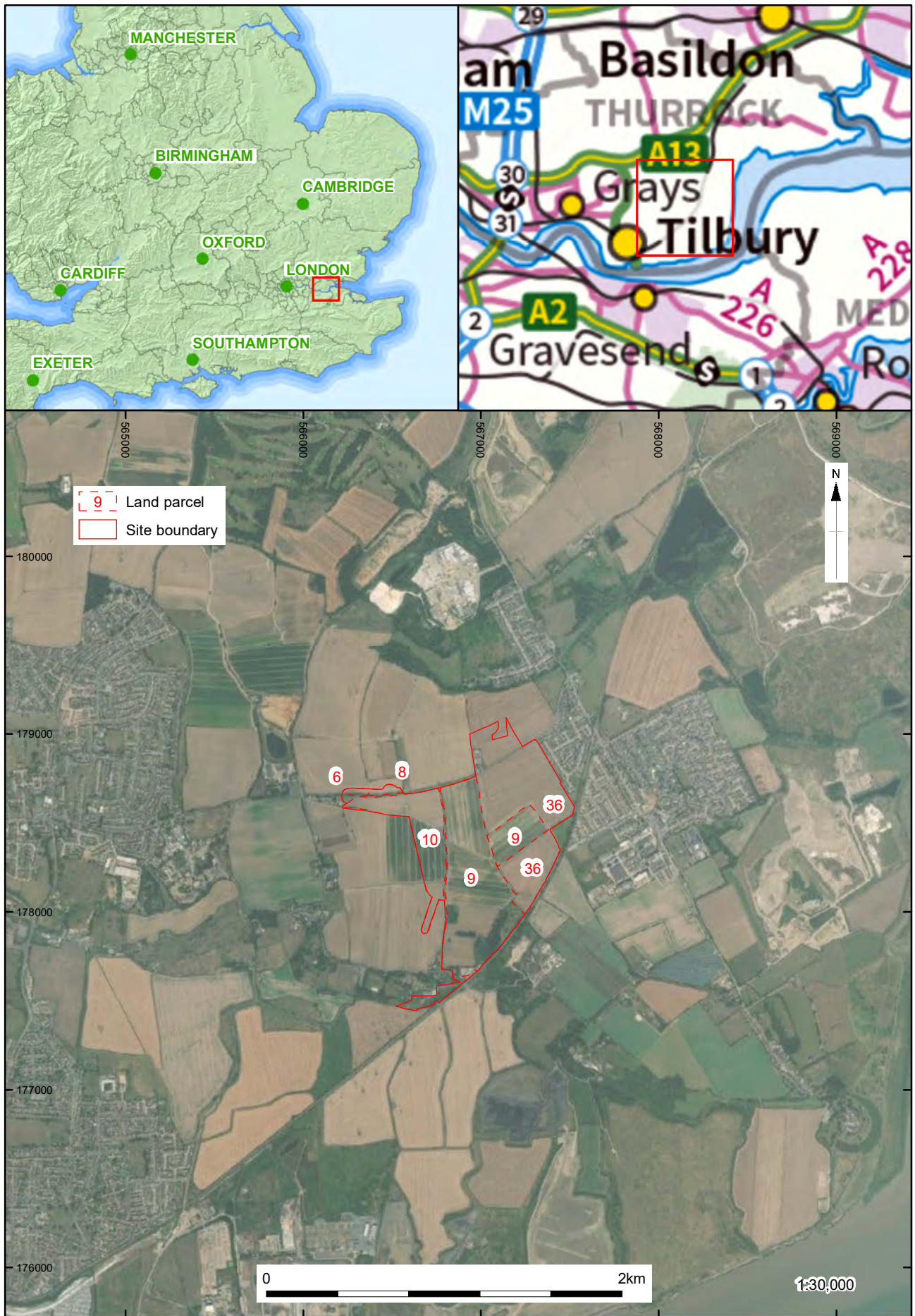
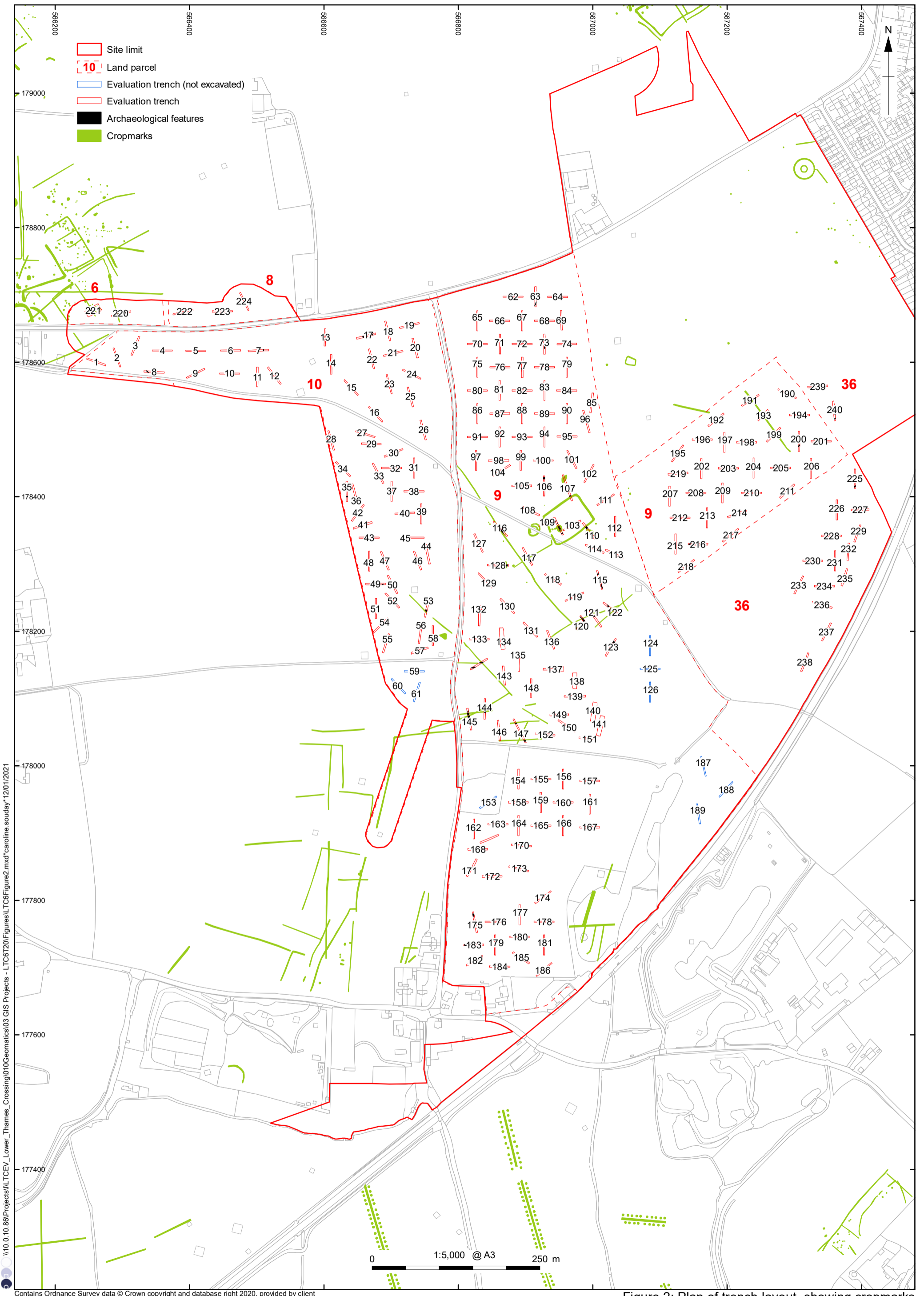

Figure 1: Site location

\\10.0.10.86\Projects\MLTCEV\_Lower\_Thames\_Crossing\010Geomatics\03 GIS Projects - LTC6120\Figures\TC6Figure1.mxd\caroline.souday\08/12/2020



I:\10.0.10.86\Projects\Lower\_Thames\_Crossing\010\Geomatics\03 GIS Projects - LTC6T20\Figures\LTC6Figure2.mxd\caroline.souday\*1201\2021

Contains Ordnance Survey data © Crown copyright and database right 2020, provided by client

Figure 2: Plan of trench layout, showing cropmarks

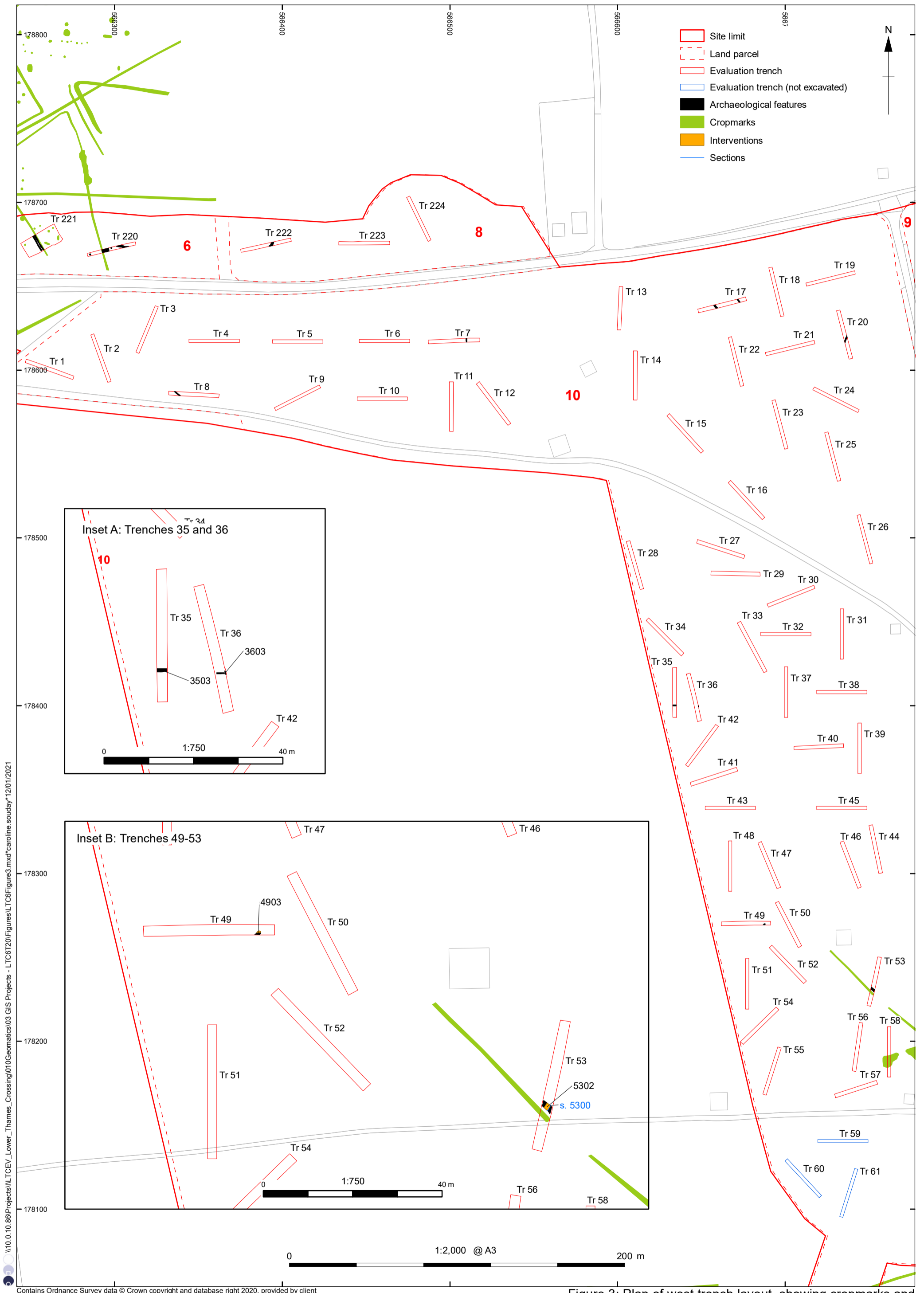

\\10.0.10.86\Projects\UL TCEV\_Lower\_Thames\_Crossing\010\Geomatics\03 GIS Projects - LTC6720\Figures\LTC6720\Figures3.mxd\*caroline.souday\*12/01/2021

Contains Ordnance Survey data © Crown copyright and database right 2020, provided by client

Figure 3: Plan of west trench layout, showing cropmarks and features, with insets of Trenches 35-36 and 49-53



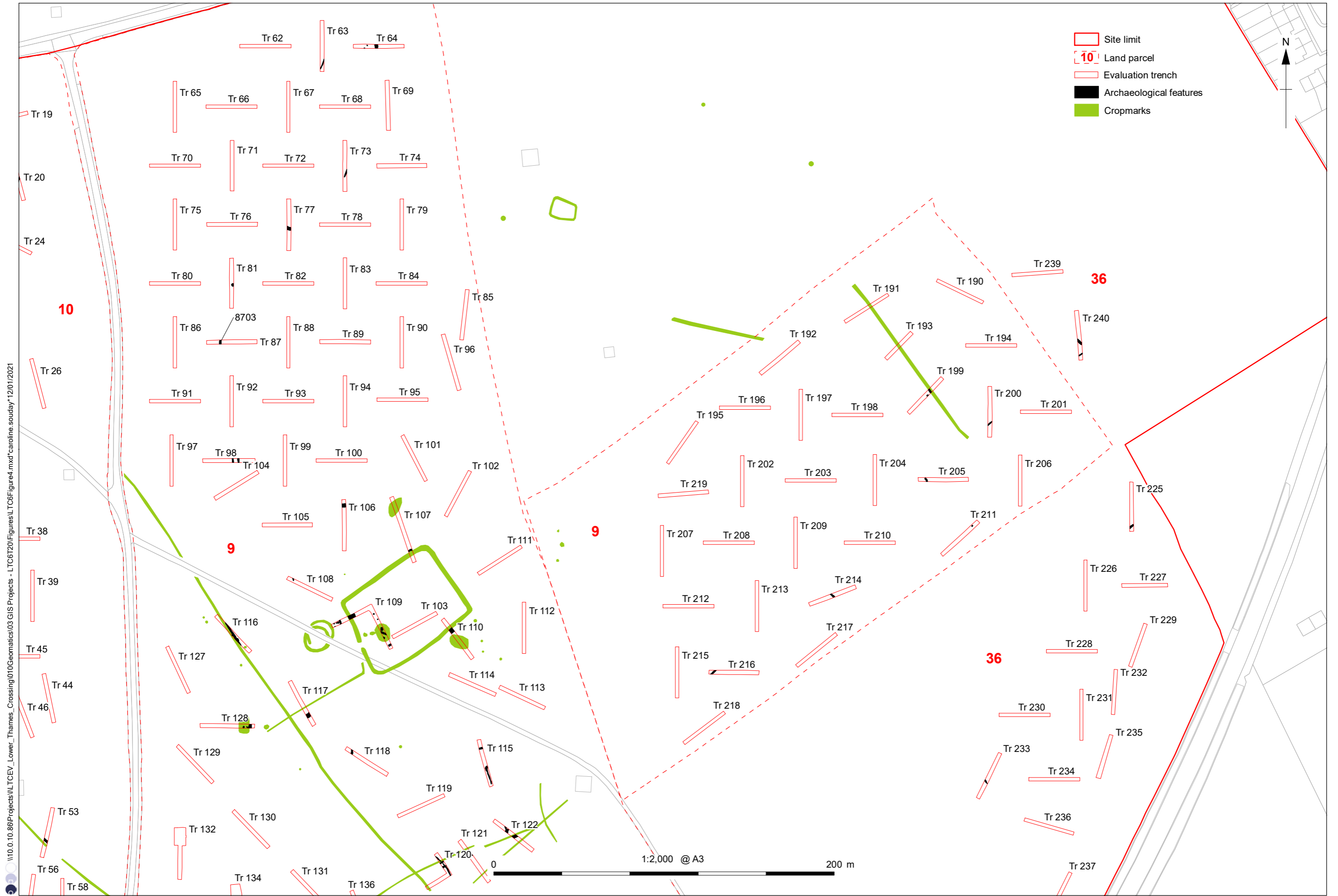

\\10.0.10.86\Projects\TCEV\_Lower\_Thames\_Crossing\010\seamatics\03\GIS\Projects - L\TC6T20\Figures\TC6Figure4.mxd\*caroline.souday\*12/01/2021

Contains Ordnance Survey data © Crown copyright and database right 2020, provided by client

Figure 4: Plan of east trench layout, showing cropmarks and features

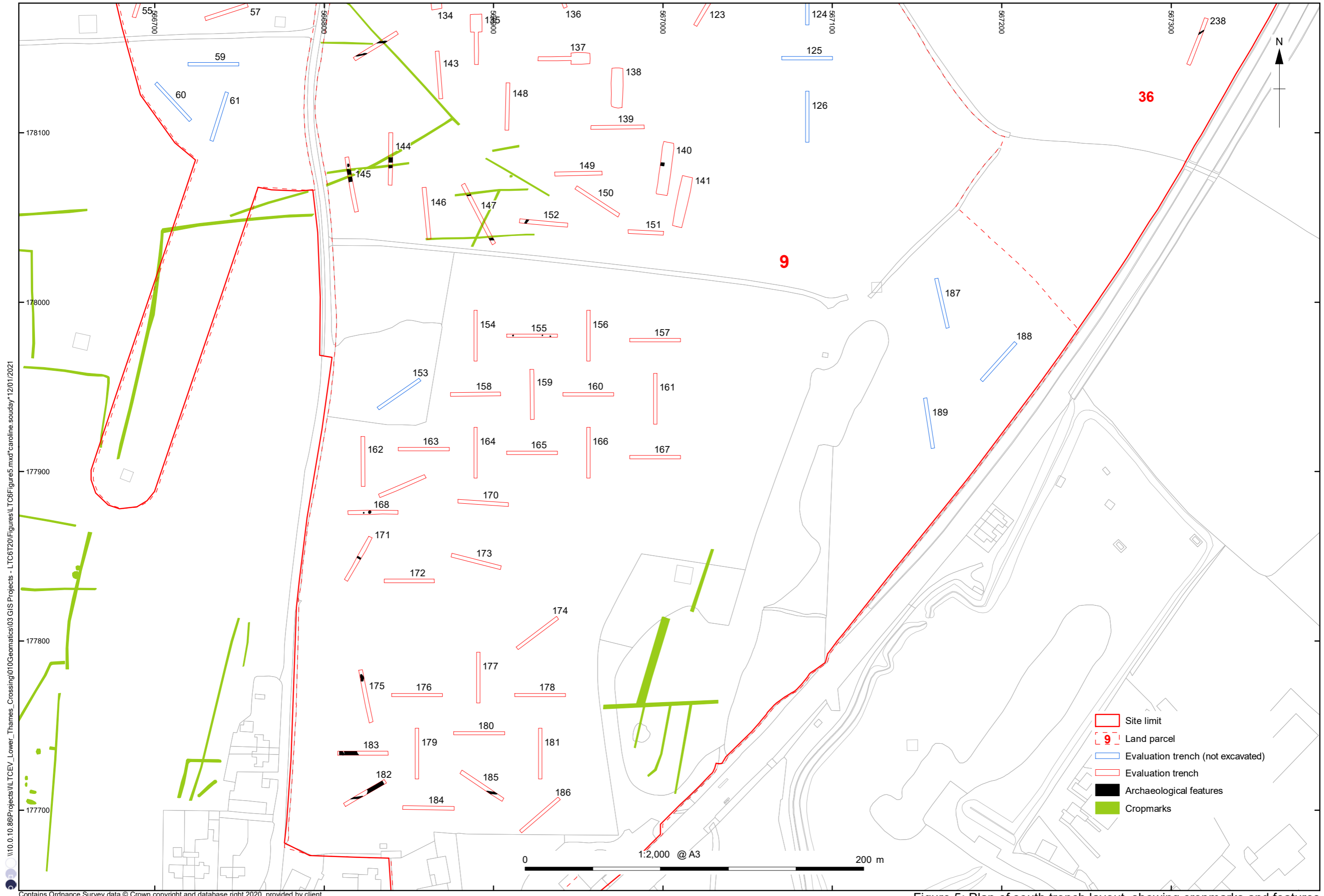
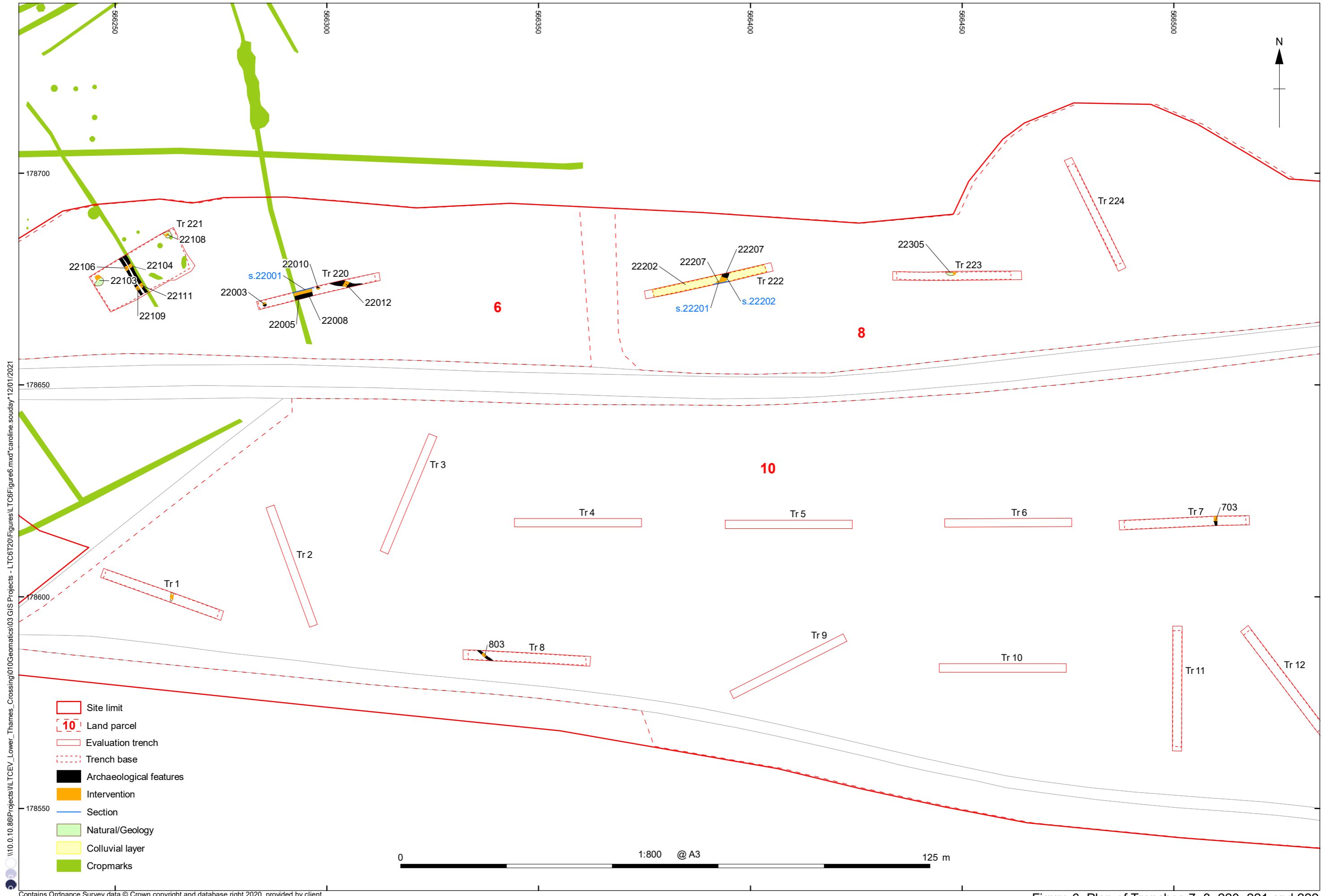

Figure 5: Plan of south trench layout, showing cropmarks and features



\\10.0.10.86\Projects\Lower\_Thames\_Crossing\010\geomatics\03 GIS Projects - LTC6T20\Figures\Trenches\TC6Figure6.mxd\*caroline.souday\*12/01/2021

Contains Ordnance Survey data © Crown copyright and database right 2020, provided by client

Figure 6: Plan of Trenches 7, 8, 220, 221 and 222

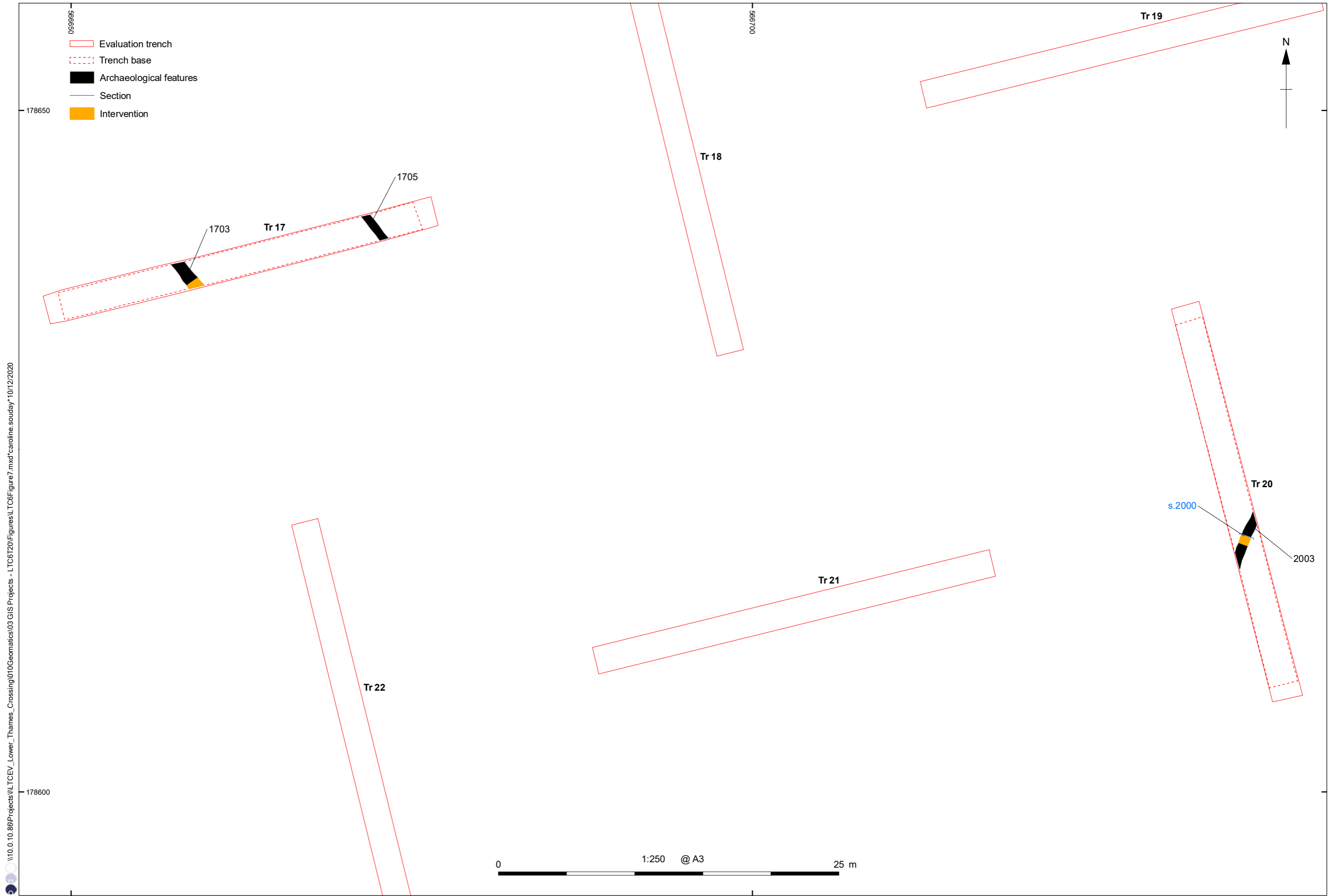

\\10.0.10.86\Projects\TCEV\_Lower\_Thames\_Crossing\010\Geomatics\03 GIS Projects - LTC6T20\Figures\TCEV\Figure7.mxd\*caroline.souday\*10/12/2020

Figure 7: Plan of Trenches 17 and 20

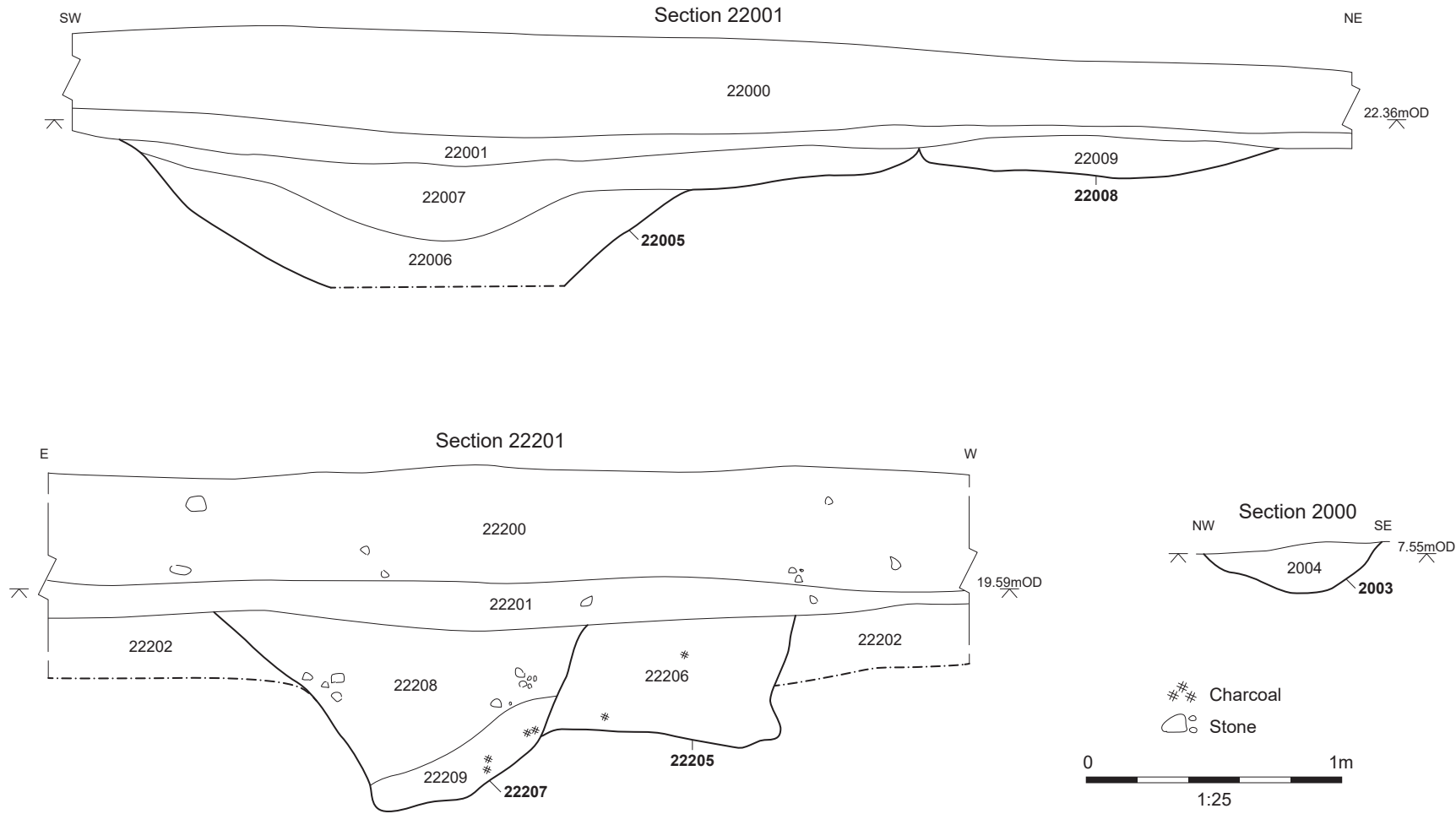

Figure 8: Sections 22001, 22201 and 2000

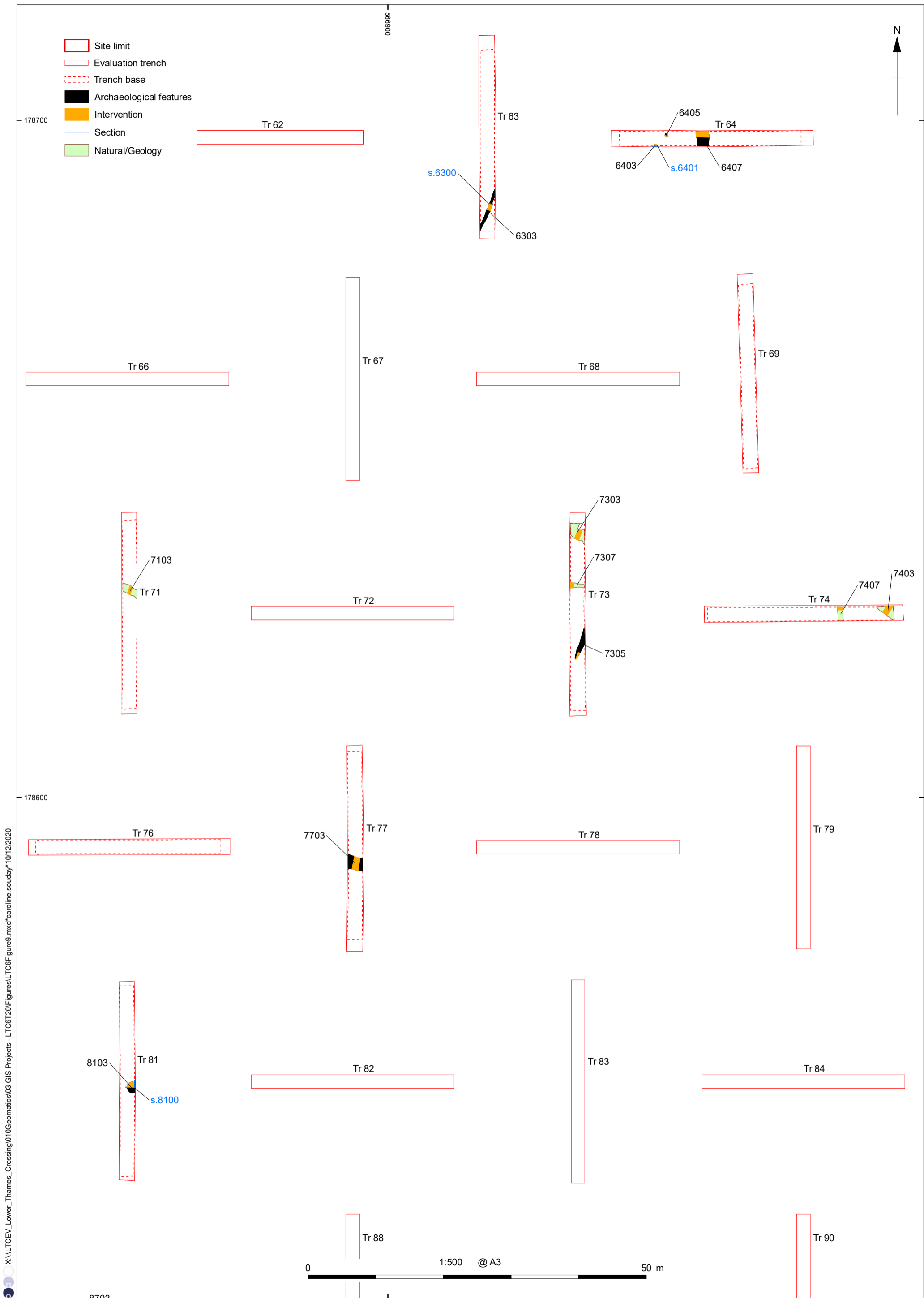

Figure 9: Plan of Trenches 63, 64, 73, 77 and 81

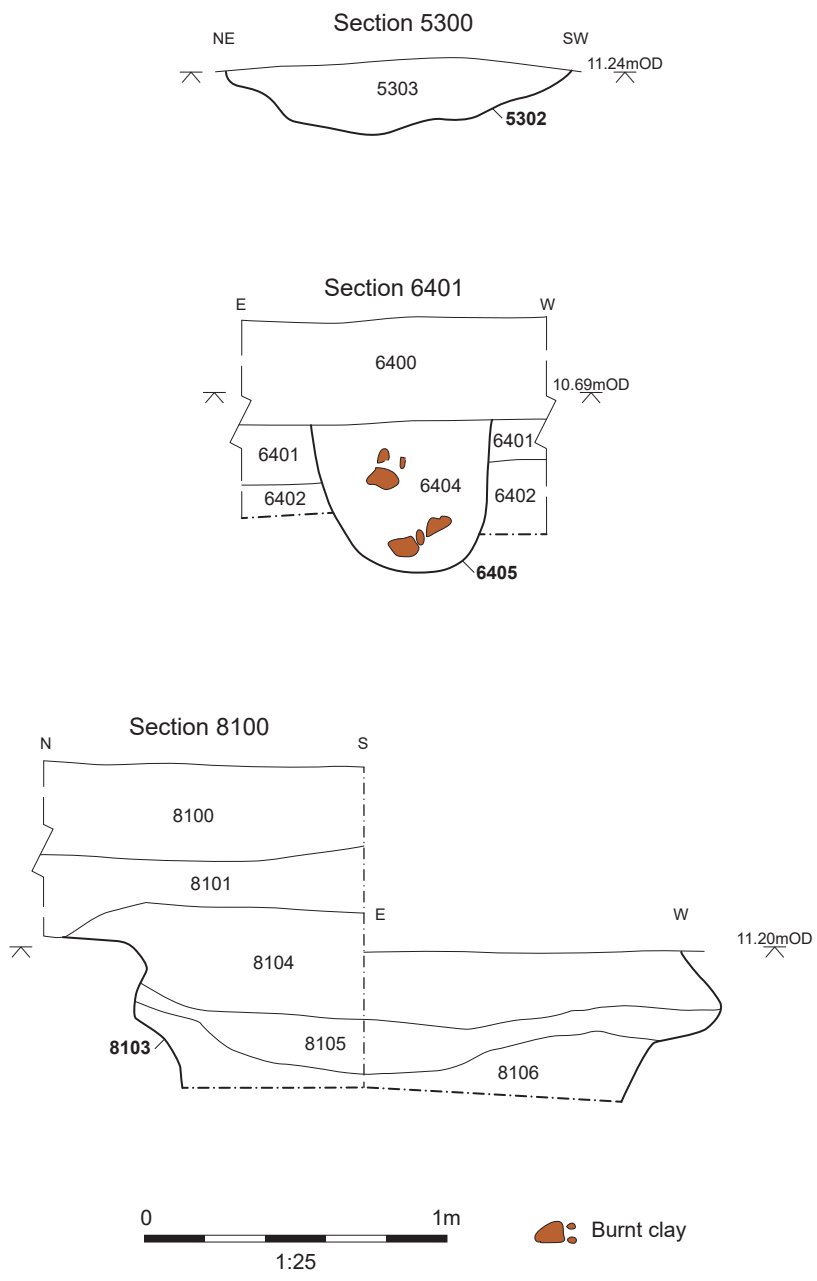

Figure 10: Sections 5300, 6401 and 8100

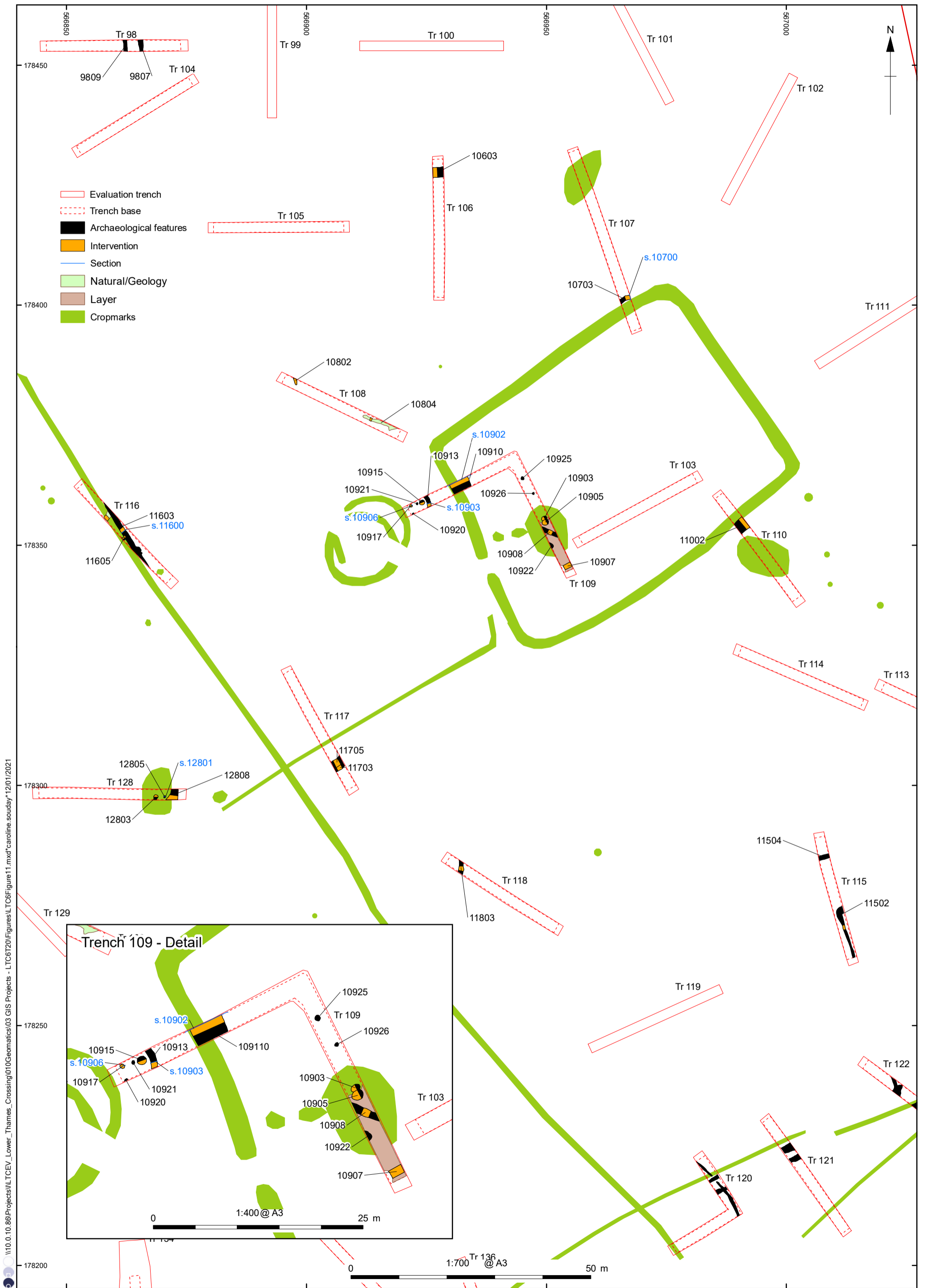

Figure 11: Plan of Trenches 98, 106-10, 115-18 and 128



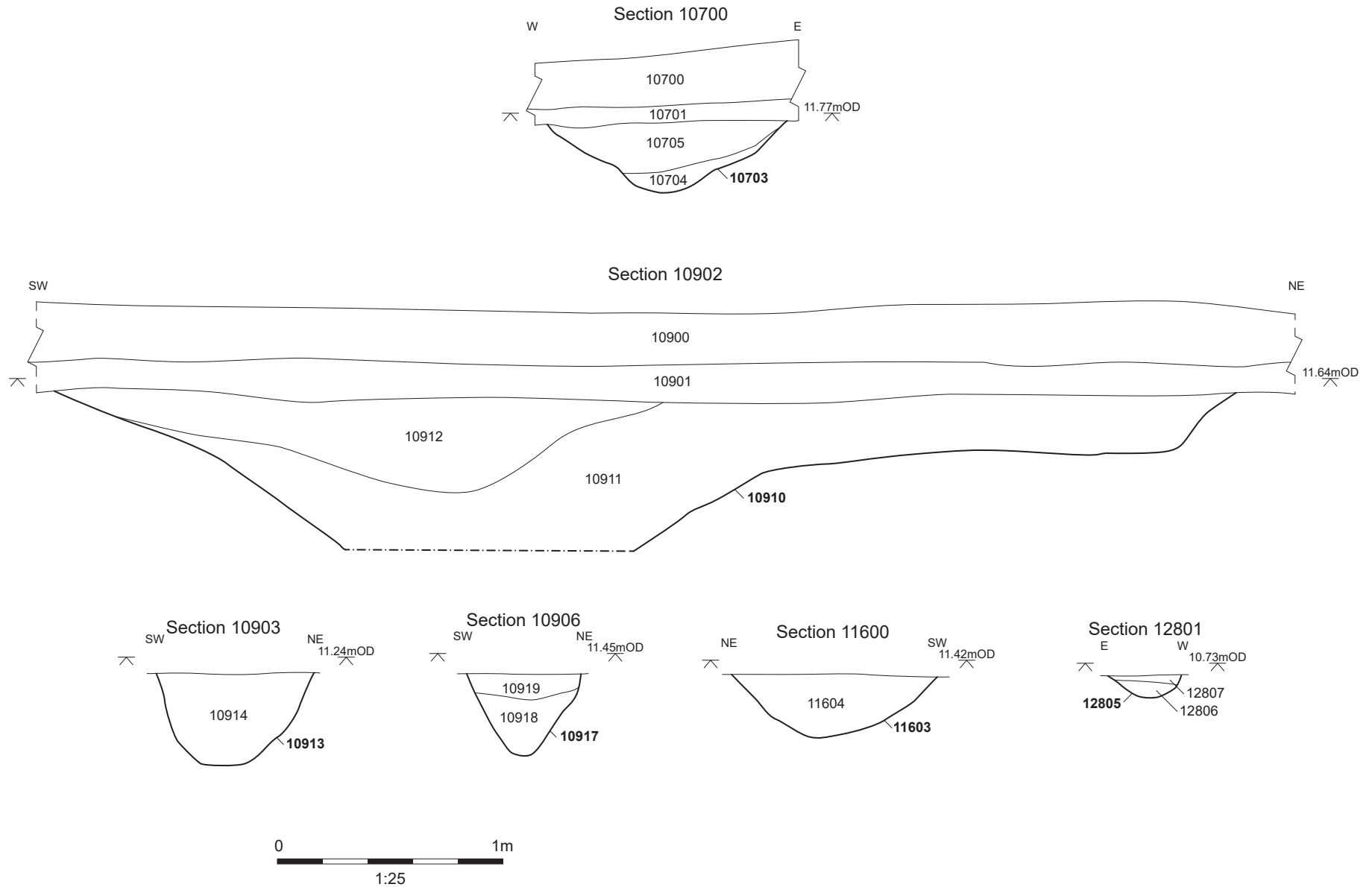

Figure 12: Sections 10700, 10902, 10903, 10906, 11600 and 12801

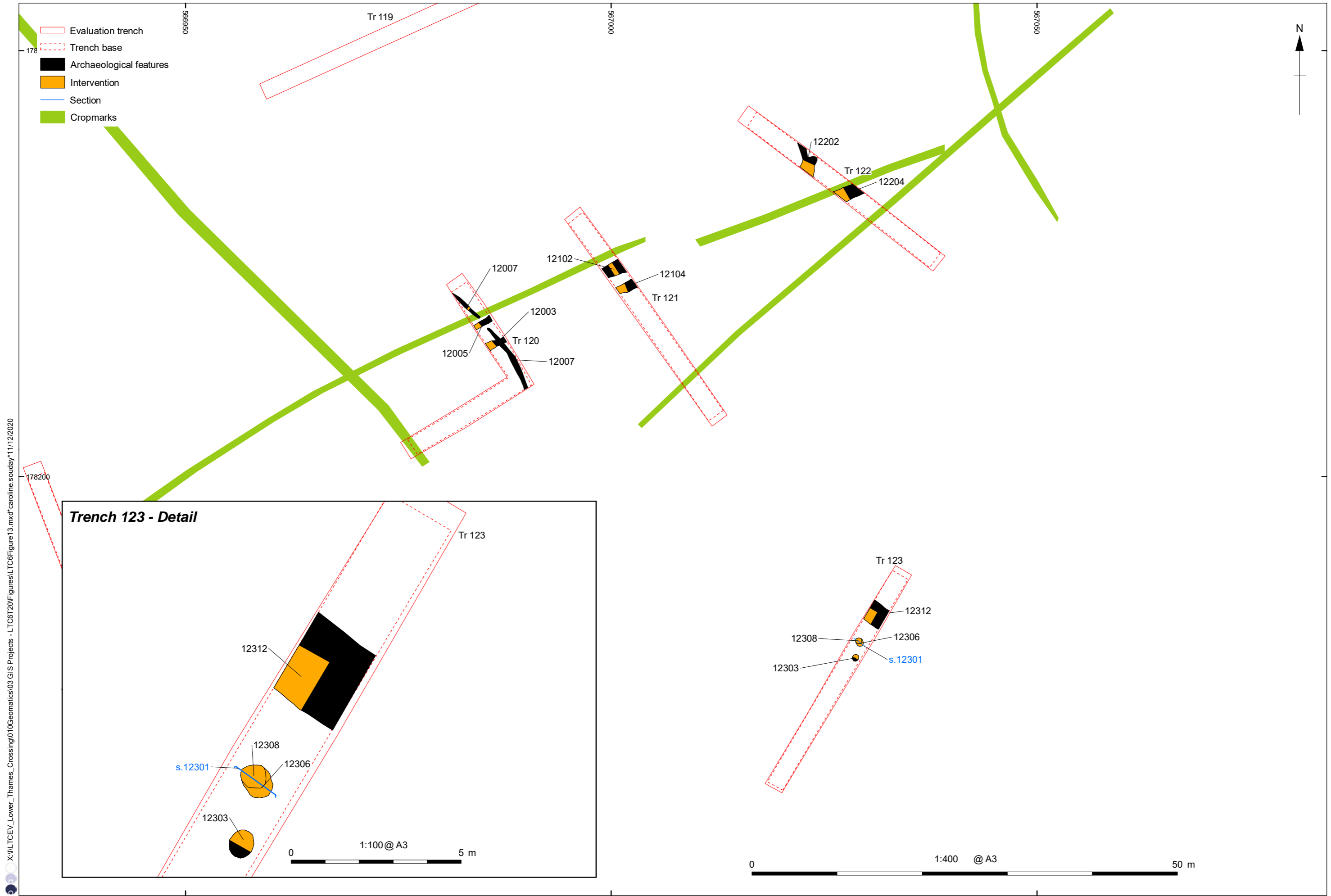

Figure 13: Plan of Trenches 120-3

X:\ILTCEV\_Lower\_Thames\_Crossing\010\Geomatics\03 GIS Projects - LT\6T20\Figures\TC6\Figure13.mxd\caroline.souday\*11/12/2020

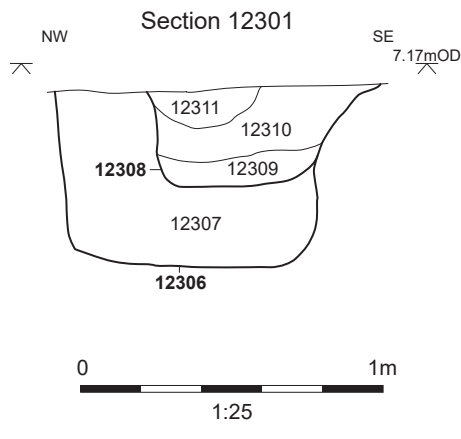

Figure 14: Section 12301

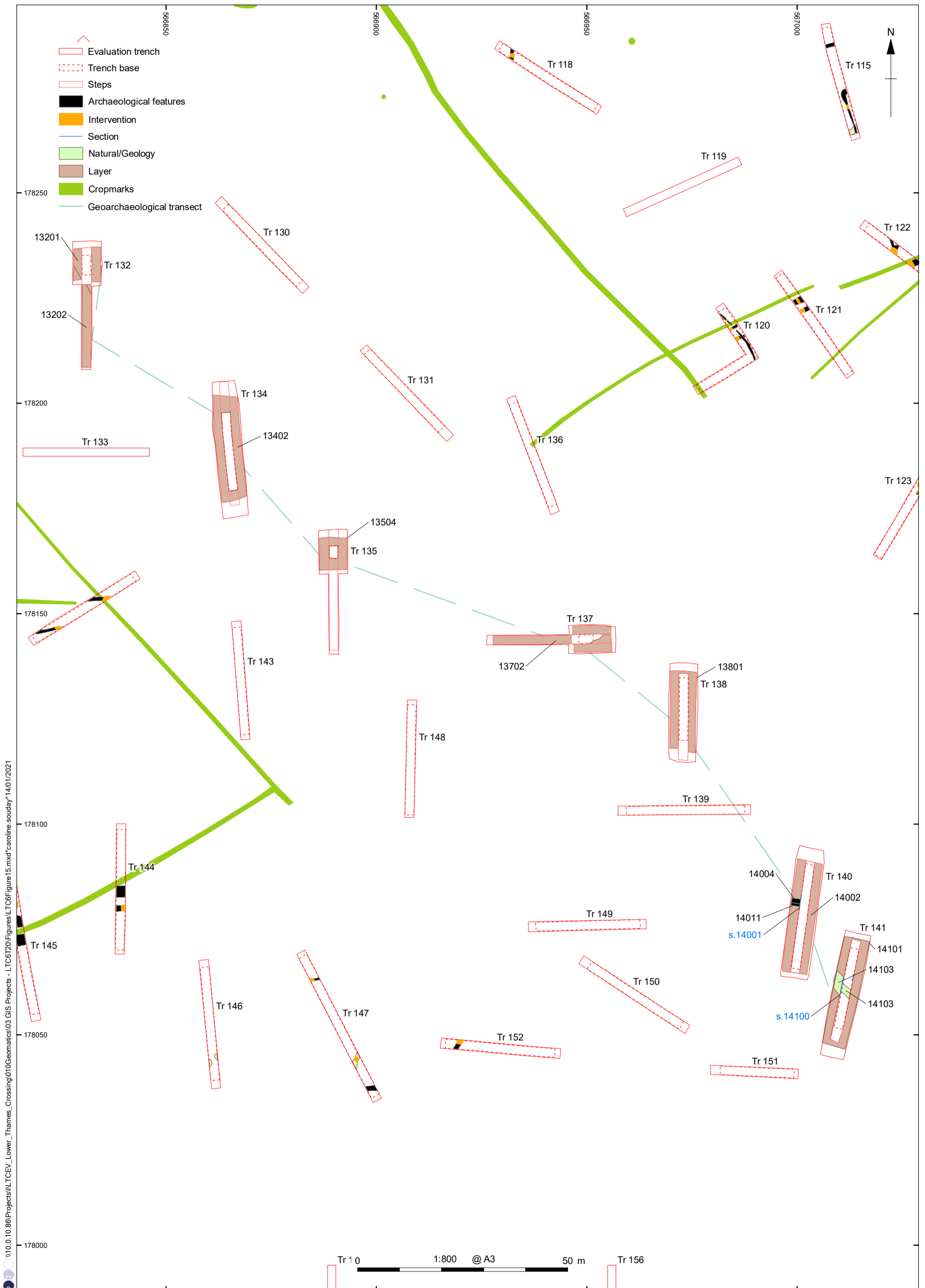

Figure 15: Plan of Trenches 132, 134-5 and 137-41

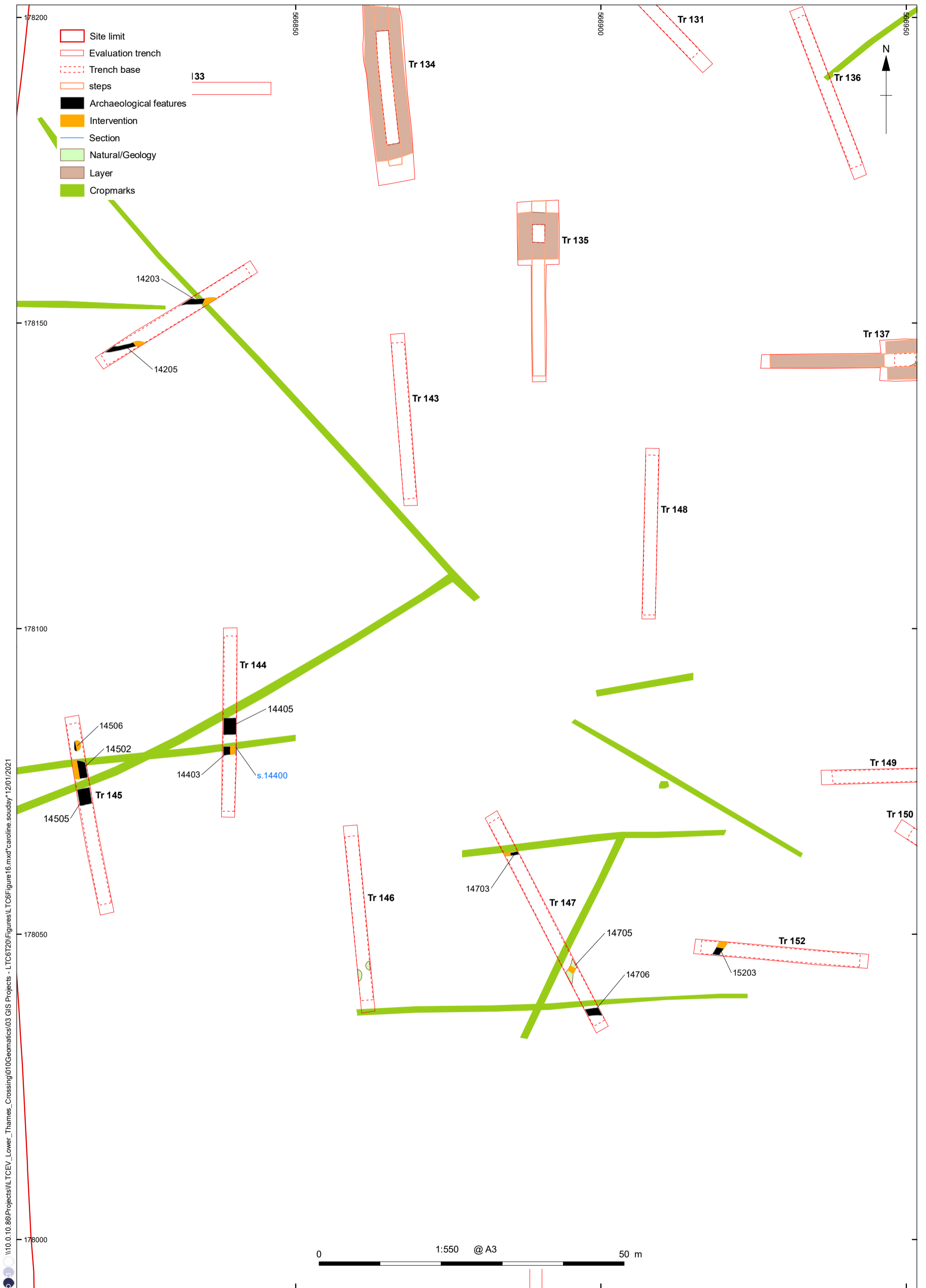

Figure 16: Plan of Trenches 142, 144-5, 147 and 152

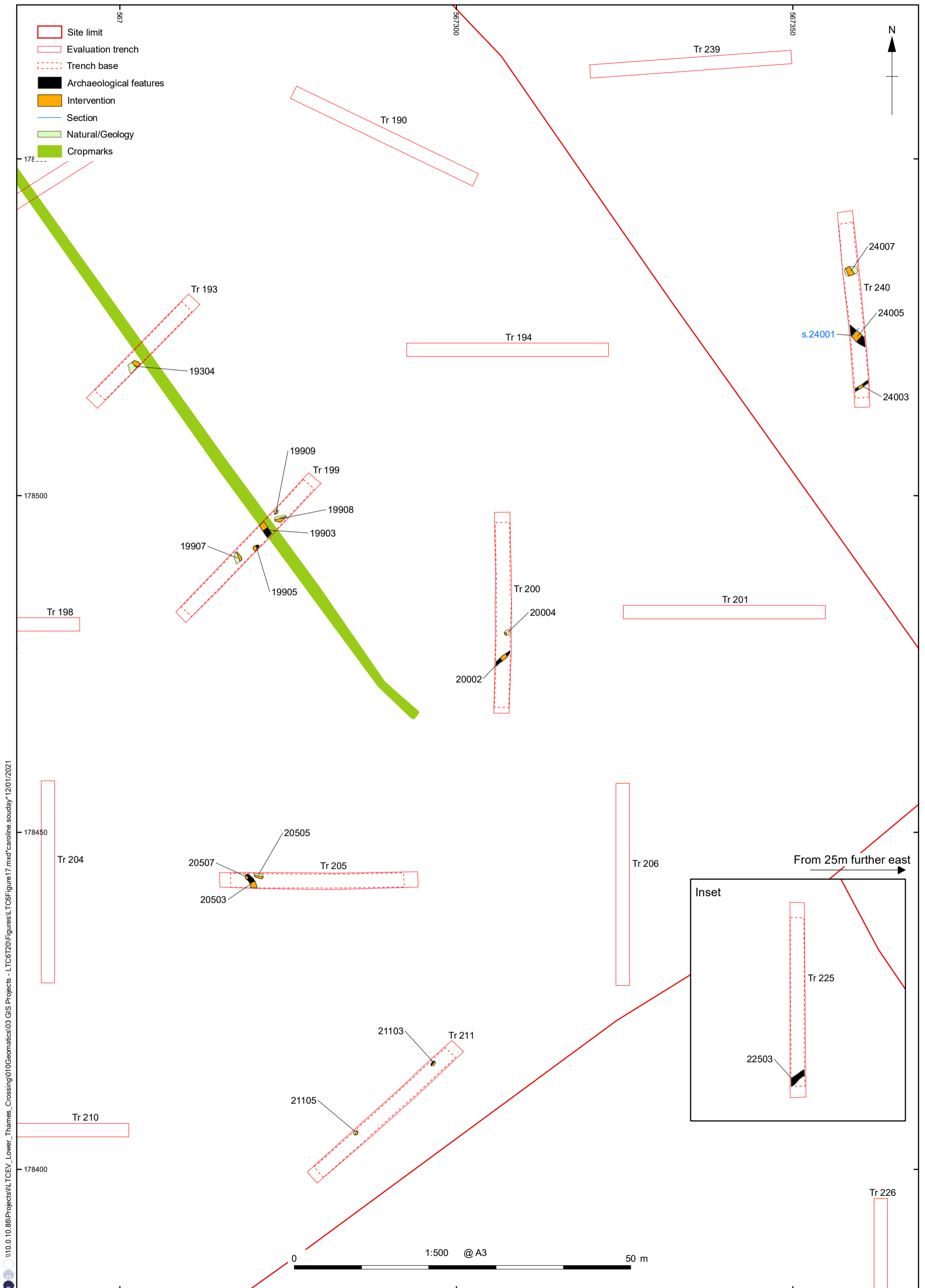

Figure 17: Plan of Trenches 193, 199, 200, 205, 211, 225 (inset) and 240

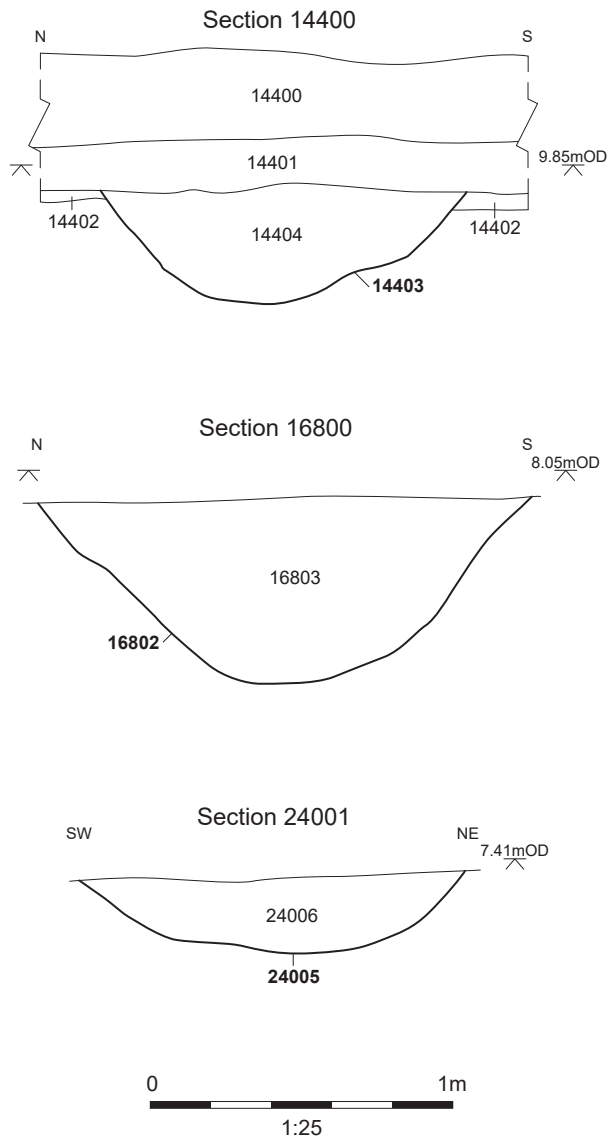

Figure 18: Sections 14400, 16800 and 24001

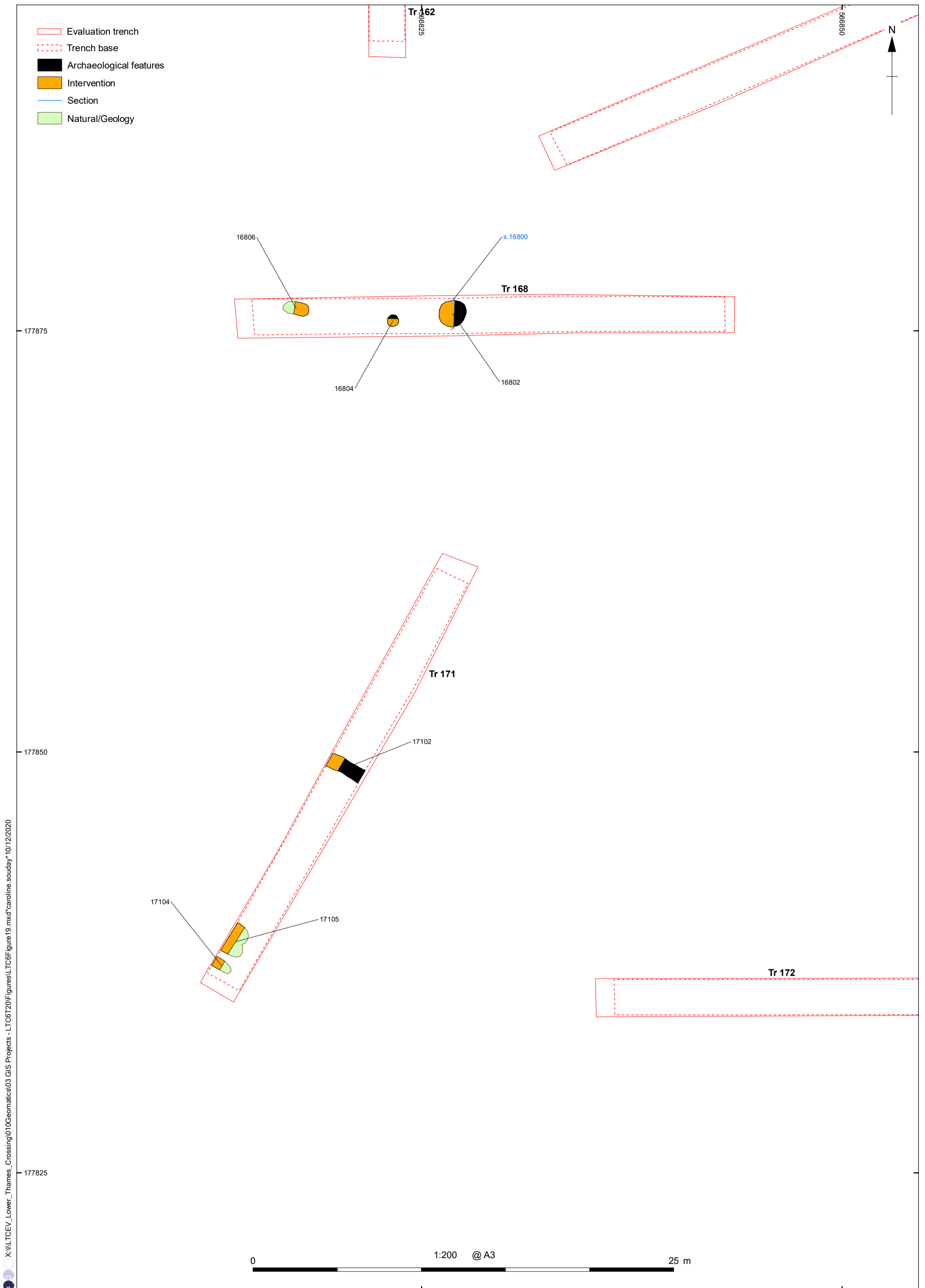

Figure 19: Plan of Trenches 168 and 171



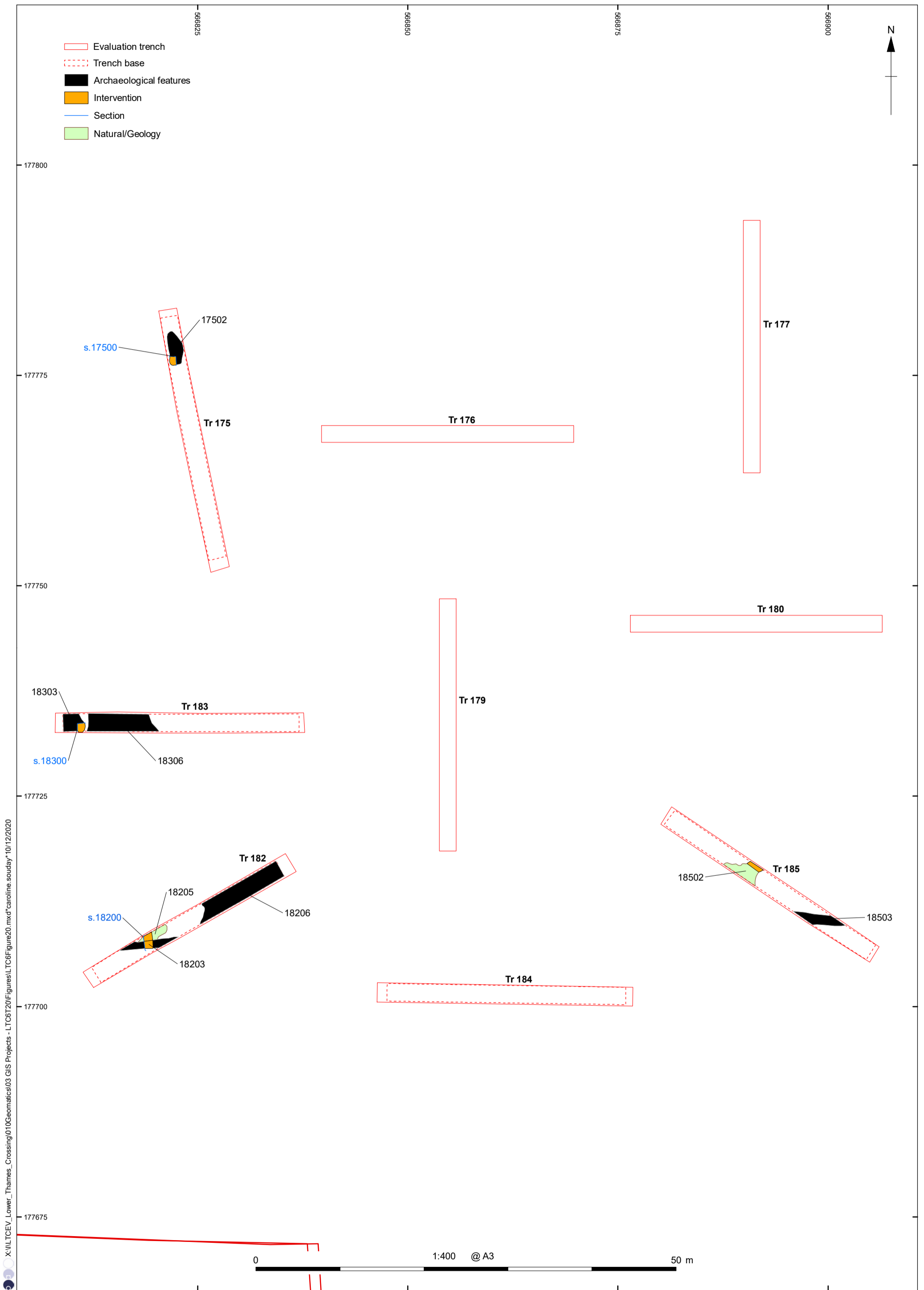

Figure 20: Plan of Trenches 175, 182-3 and 185

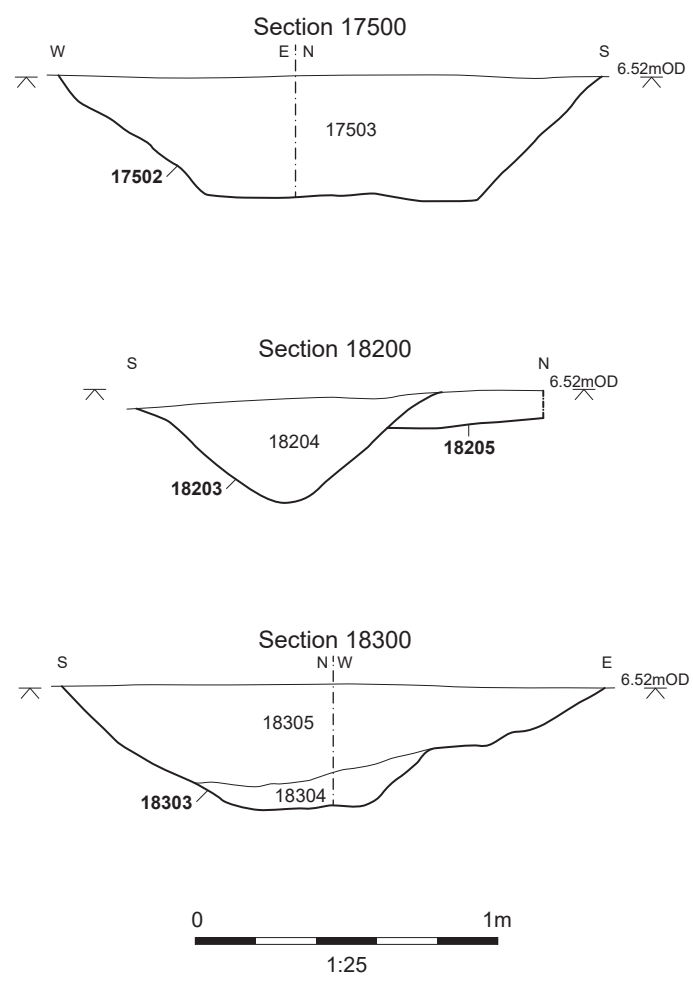

Figure 21: Sections 17500, 18200 and 18300

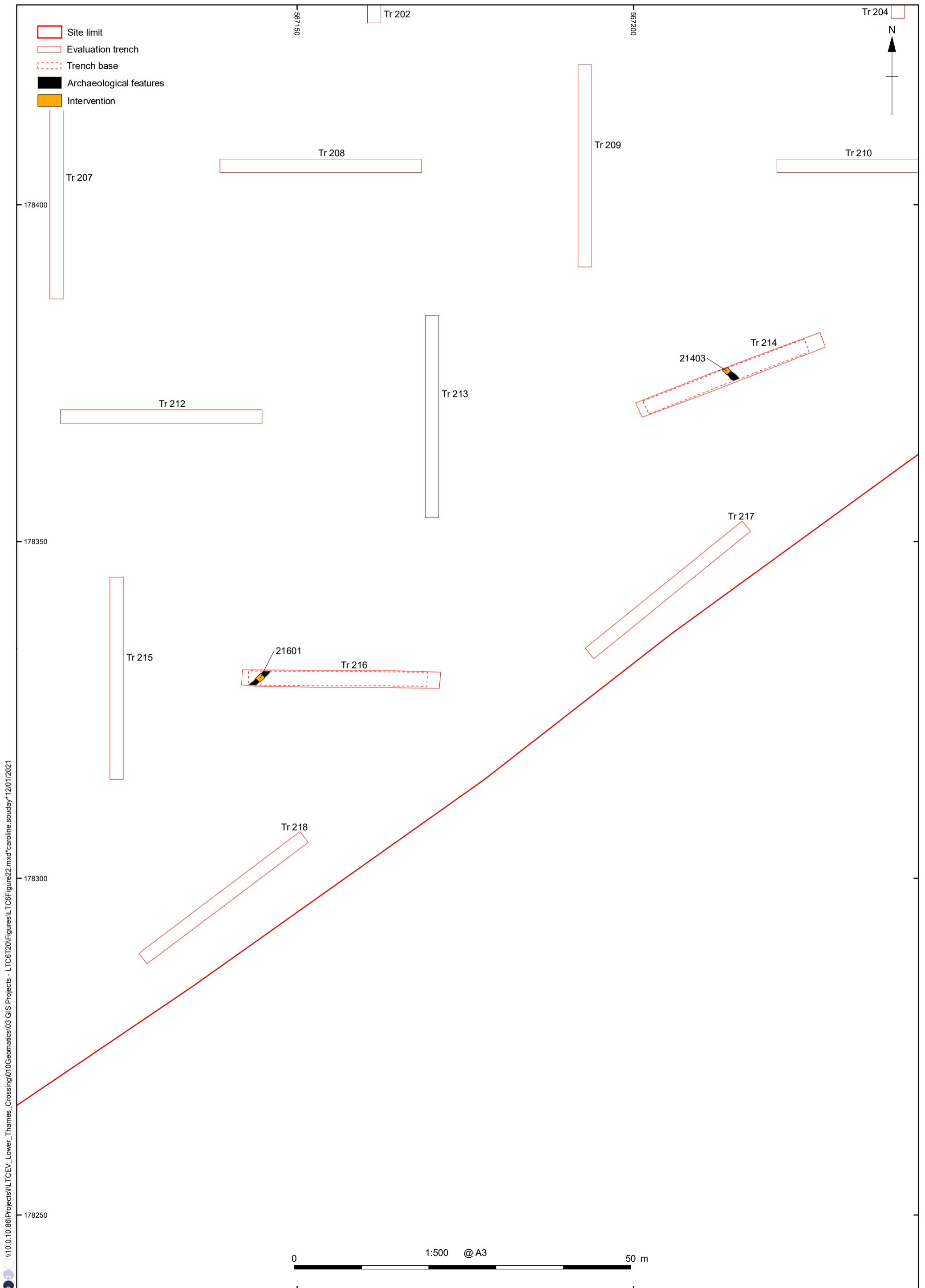
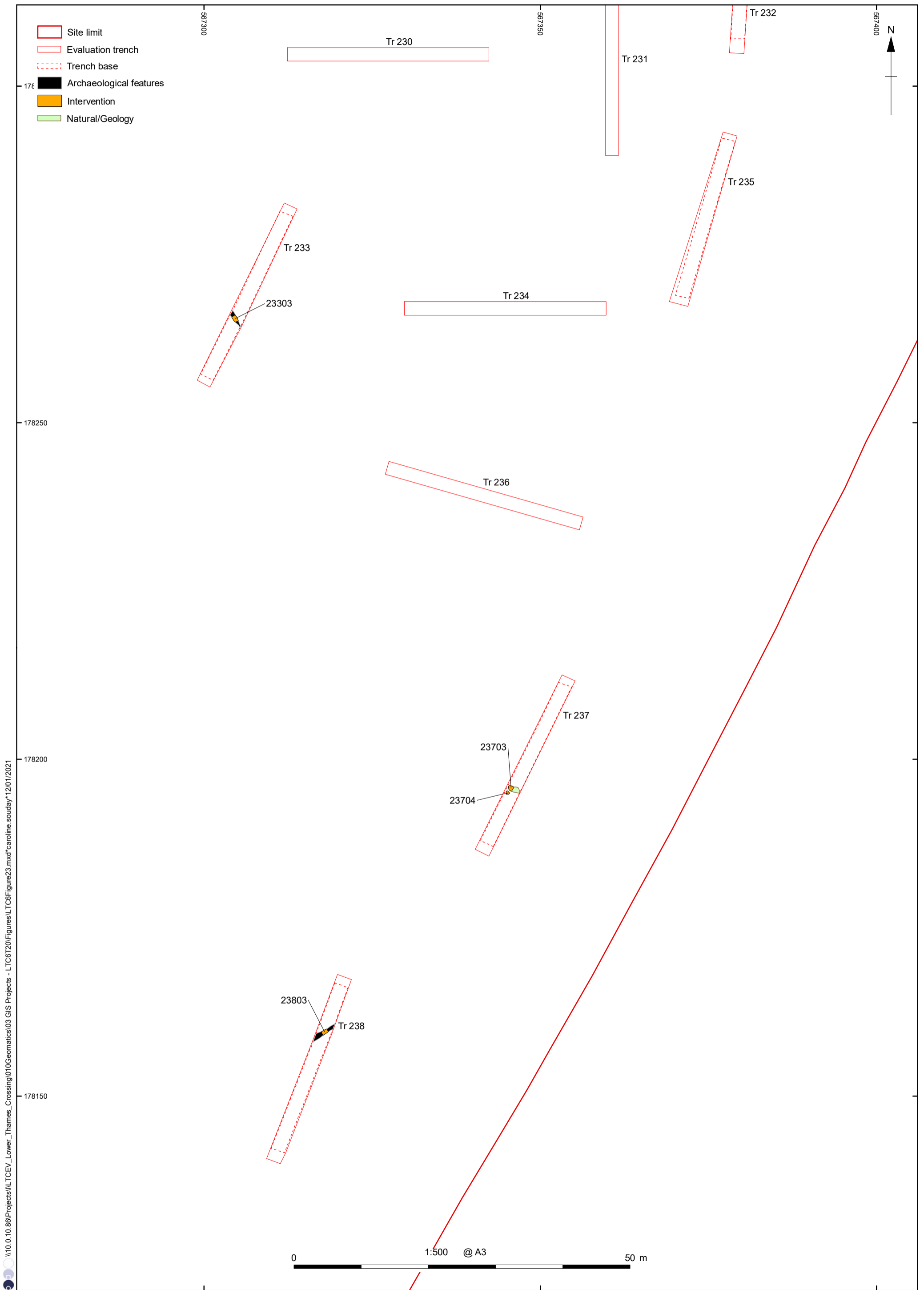

Figure 22: Plan of Trenches 214-18



\\10.0.10.86\Projects\ILTCEV\_Lower\_Thames\_Crossing\010\Geomatics\03 GIS Projects - LTC6T20\Figures\LTC6\Figure23.mxd\*caroline.souday\*12/01/2021

Figure 23: Plan of Trenches 233-8

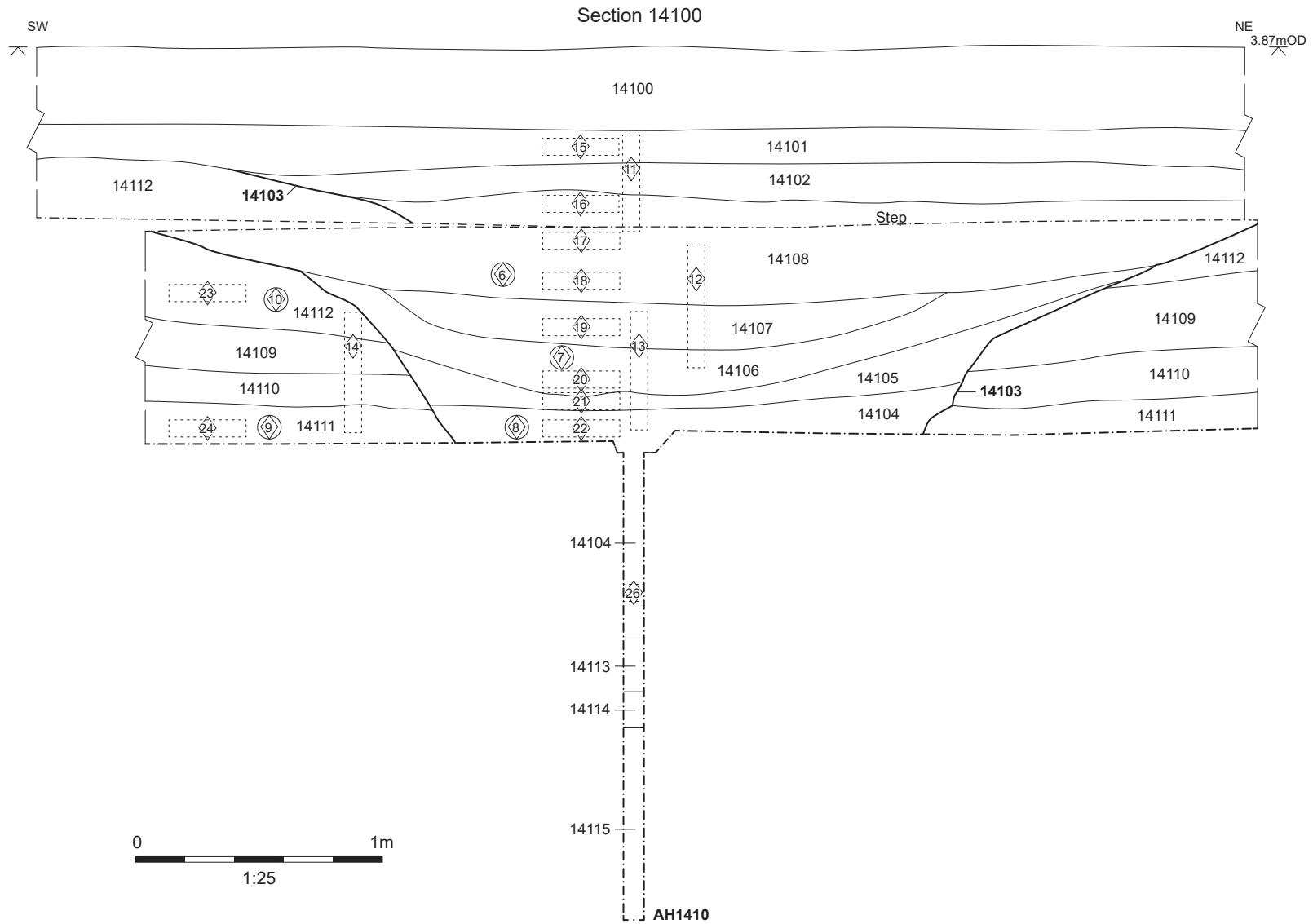

Figure 24: Section 14100

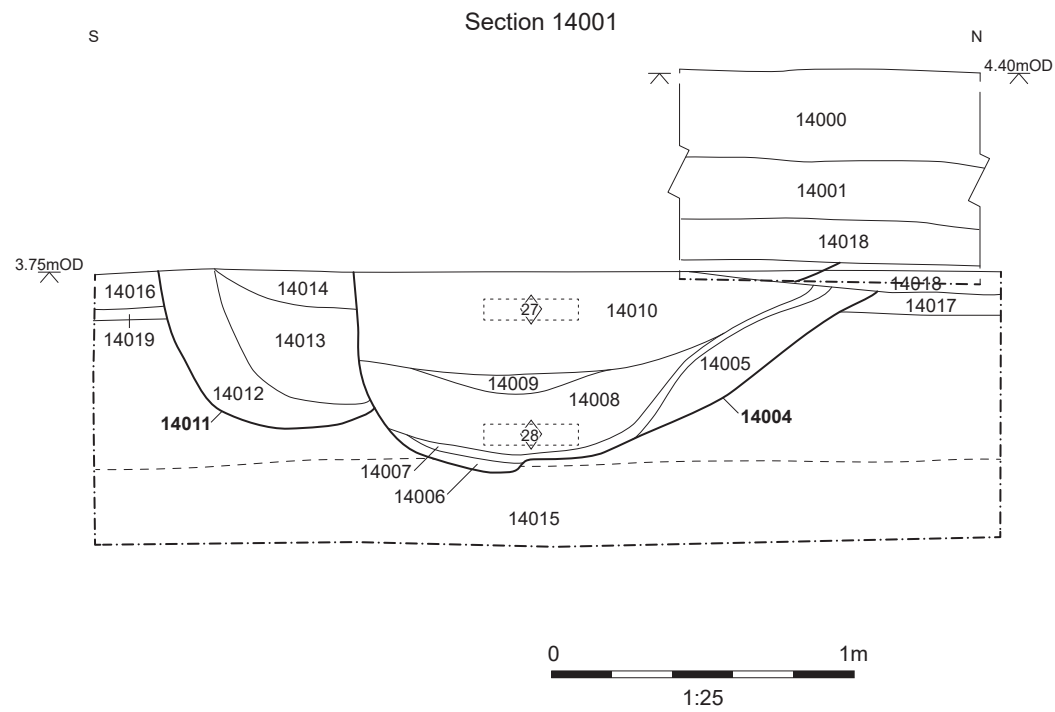

Figure 25: Section 14001

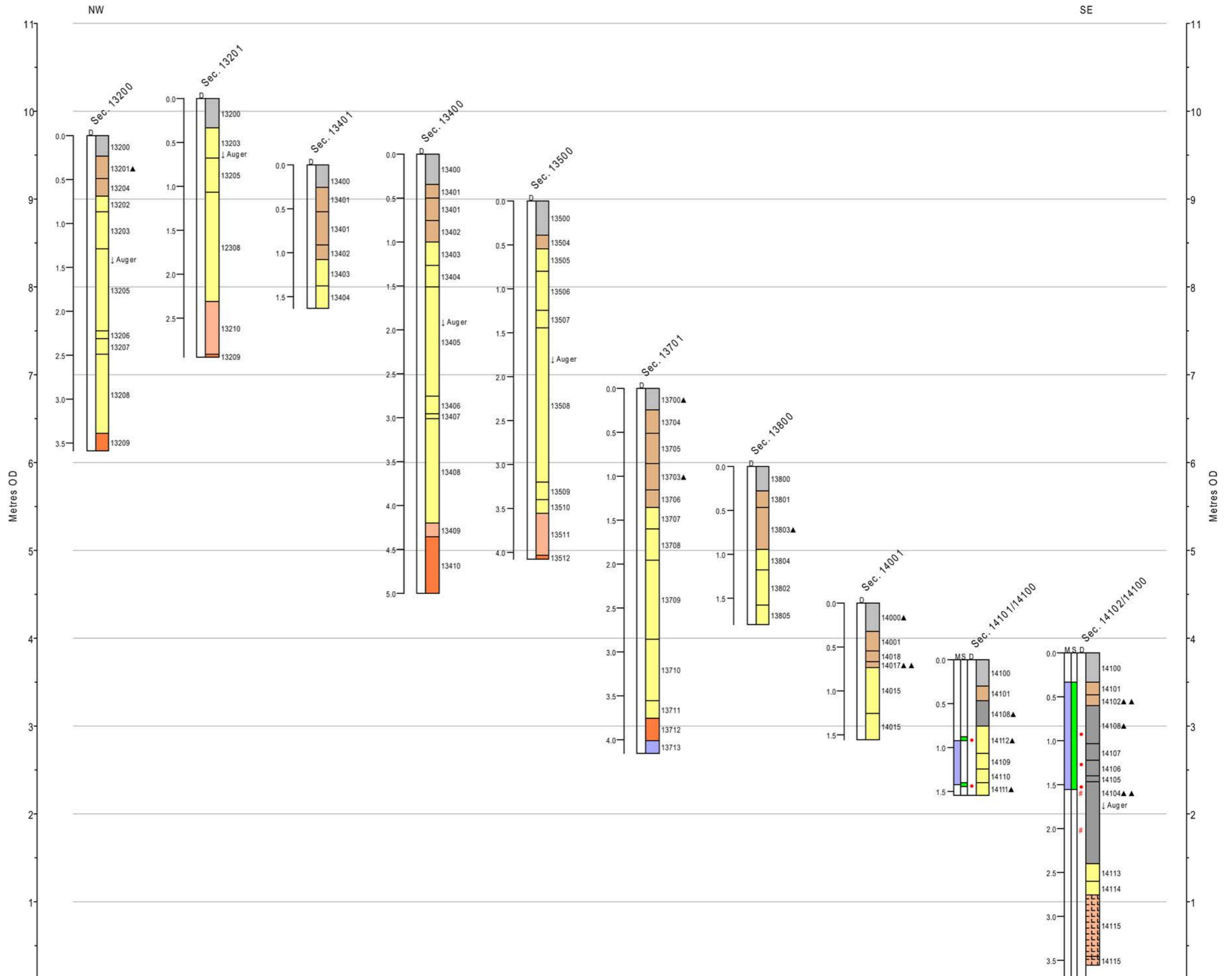

Figure 26: Geoarchaeological transect across Trenches 132, 134-5, 137-8, and 140-1



Plate 1: Ditch 22005, looking north-east



Plate 2: Ditch 22207 and pit 22205, looking south





Plate 3: Pit 6403, looking south



Plate 4: Fired clay objects in pit 6403, looking south



Plate 5: Pit 8103, looking south



Plate 6: Ditch 10910, looking north-west



Plate 7: 10925, *in situ* ceramic vessel



Plate 8: Section 12802, looking south west



Plate 9: Pits 12306 and 12308, looking south west



Plate 10: Ditch 24005, looking north-west

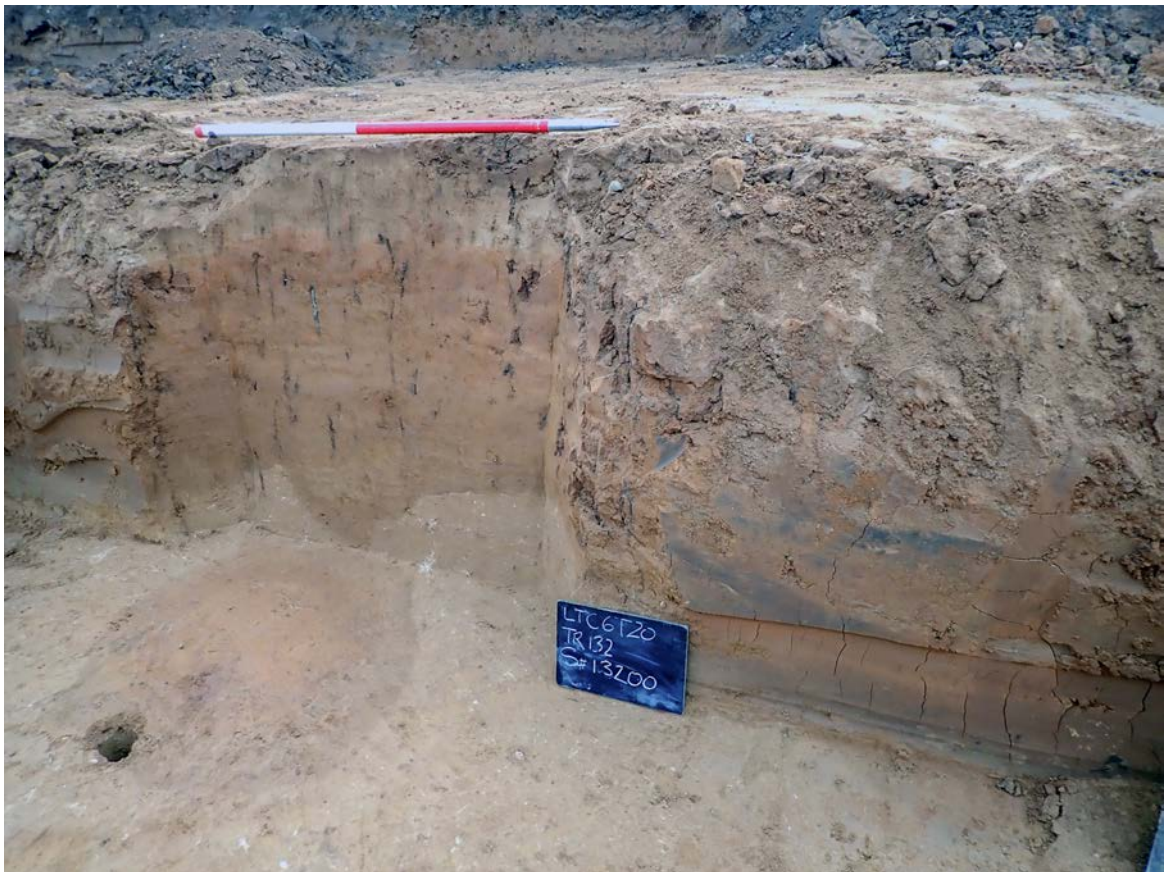

Plate 11: Geoarchaeological Section 13200



Plate 12: Geoarchaeological Section 13400



Plate 13: Trench 135

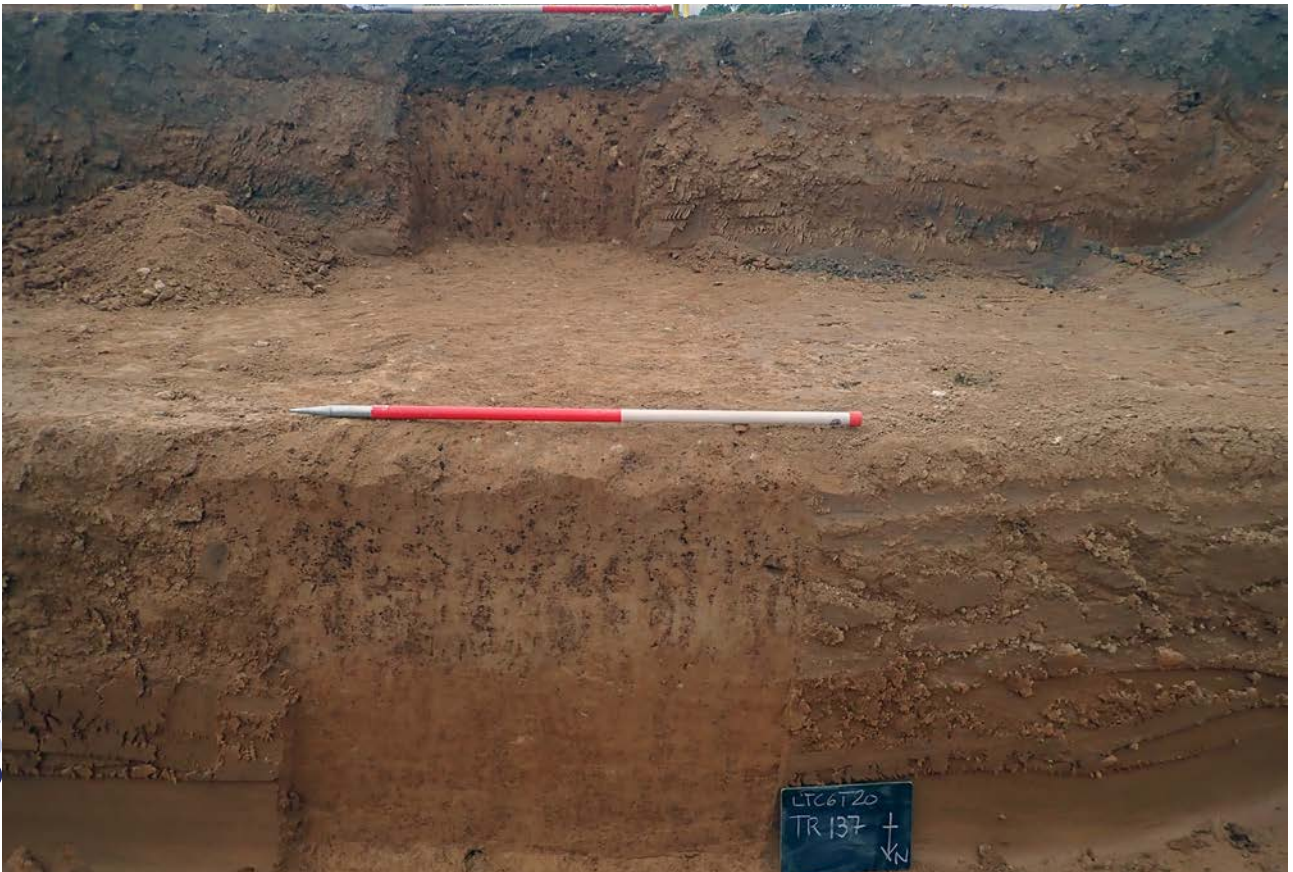

Plate 14: Geomorphological Section 13701



Plate 15: Geomorphological Section 13800



Plate 16: Geotechnical Section 14100



Plate 17: Geotechnical Section 14100 showing location of samples



Plate 18: Geoarchaeological Section 14001



## COVER SHEET

<b>Title:</b>	Archaeological Evaluation Report for Trial Trenching of Land Parcels 6-8, Land West of Linford, East Tilbury, Essex
<b>Project Name:</b>	Lower Thames Crossing Enabling Works
<b>Ref No:</b>	HE540039-BAL-GEN-GEN-REP-HER-00042
<b>Revision No:</b>	P01
<b>Review Date:</b>	02/02/2022
<b>Status:</b>	S2 – For Information
<b>No. of Pages</b>	409

Rev	Date of Issue	Revision Status	Originator	Checker	Approver
P01	02/02/2022	S2	Conal Mundy	Jack Fletcher	Emily Erswell



# Lower Thames Crossing

Archaeological Evaluation Report for Trial Trenching of  
Land Parcels 6-8, Land West of Linford, East Tilbury, Essex

Document Number: HE540039-BAL-GEN-GEN-REP-HER-00042

**January 2021**



Revision	Production Date	Prepared by	Checked by	Approved for release by	Sections revised
1.1	February 2022	Mark Dodd Project Officer Tim Allen Senior Project Manager Oxford Archaeology	Steve Lawrence Project Manager Oxford Archaeology		

This Evaluation Report has been prepared for Highways England in accordance with the terms and conditions of appointment stated in the Lower Thames Crossing (LTC) Technical Partner Contract. LTC cannot accept any responsibility for any use of or reliance on the contents of this document by any third party.

# Contents

---

Section	Page
<b>Contents</b> .....	<b>3</b>
<b>Summary</b> .....	<b>12</b>
<b>Acknowledgements</b> .....	<b>14</b>
<b>1 Introduction</b> .....	<b>15</b>
1.1 Project details and scope of work .....	15
1.2 Location, topography and geology .....	15
1.3 Previous investigations .....	16
1.4 Archaeological and historical background.....	18
<b>2 Project Aims</b> .....	<b>31</b>
2.1 General aims .....	31
2.2 Specific objectives .....	32
<b>3 Methodology</b> .....	<b>34</b>
3.1 Constraints.....	34
3.2 Methodology for the evaluation .....	34
<b>4 Results</b> .....	<b>36</b>
4.1 Introduction and presentation of results .....	36
4.2 General soils and ground conditions.....	36
4.3 General distribution of archaeological deposits .....	37
4.4 Trenches 3-5 and 7-11 (Figs 3, 6 and 7).....	38
4.5 Trenches 17, 20, 27, 28 and 32 (Figs 3, 8 and 9) .....	40
4.6 Trenches 40- and 48-9 (Figs 3, 10 and 11).....	42
4.7 Trenches 60-1, 67-9, 75-7 and 85 (Figs 4, 12 and 13) .....	44
4.8 Trenches 90 and 101-2 (Figs 4, 14 and 15).....	47
4.9 Trenches 91-4 (Figs 4, 16 and 17).....	49
4.10 Trenches 95, 99 and 103-4 (Figs 4, 18 and 19).....	53
4.11 Trenches 100, 105 and 109 (Figs 4, 20 and 21) .....	56
4.12 Trenches 79, 89, 96-8 and 107 (Figs 4, 22 and 23).....	57
4.13 Trenches 113, 120 and 126-7 (Figs 4, 24 and 25).....	60
4.14 Trenches 138-9 and 141 (Figs 5, 26 and 27).....	61
4.15 Trenches 140 and 162-168 (Figs 5, 28 and 29).....	63
4.16 Trenches 170 and 174-6 (Figs 5, 30 and 31).....	65
4.17 Trenches 149-50 and 152 (Figs 5, 32 and 33).....	68
4.18 Trenches 178-9, 182-4 and 187 (Figs 5, 34 and 35).....	69
4.19 Trenches 151, 180-1, 185-6, 190-1, and 196 (Figs 5, 36 and 37).....	71
4.20 Trenches 194, 197-8 and 202 (Figs 5, 38 and 41) .....	75
4.21 Trenches 159, 161, 207-8 and 213 (Figs 5, 39 and 41) .....	75
4.22 Trenches 216, 223 and 226 (Figs 5, 40 and 41) .....	76
4.23 Trenches 229-30 and 233-5 (Figs 5, 42 and 43).....	77
4.24 Trenches 237-243 (Figs 5, 44 and 45).....	78
4.25 Finds summary .....	80

4.26	Environmental summary .....	81
<b>5</b>	<b>Discussion .....</b>	<b>83</b>
5.1	Reliability of field investigation .....	83
5.2	Interpretation.....	84
5.3	Evaluation objectives and results.....	91
<b>Appendix A</b>	<b>Trench Tables .....</b>	<b>94</b>
<b>Appendix B</b>	<b>Finds Reports .....</b>	<b>237</b>
<b>Appendix C</b>	<b>Environmental Reports .....</b>	<b>286</b>
<b>Appendix D</b>	<b>References .....</b>	<b>322</b>
<b>Appendix E</b>	<b>Abbreviations and Glossary .....</b>	<b>330</b>
<b>Appendix F</b>	<b>Site Summary.....</b>	<b>332</b>

## Figures

Figure 1: Site location

Figure 2: Trench layout and cropmark features, Land Parcels 6, 7a/b/c and 8

Figure 3: Trench layout showing archaeological features and cropmarks, Land Parcel 6

Figure 4: Trench layout showing archaeological features and cropmarks, Land Parcel 7a/b

Figure 5: Trench layout showing archaeological features and cropmarks, Land Parcels 7c and 8

Figure 6: Detailed plan of Trenches 3, 5 and 7-11

Figure 7: Sections 304, 305, 702, 800, 900, 1000, 1101

Figure 8: Detailed plan of Trenches 17, 27, 28 and 32

Figure 9 Sections 1700, 2700, 2800, 2801, 3201, 3202

Figure 10: Detailed plan of Trenches 40, 41, 42, 48 and 49

Figure 11: Sections 4000, 4201, 4800, 4803, 4900

Figure 12: Detailed plan of Trenches 61, 67-9, 75-7 and 85

Figure 13: Sections 6102, 6802, 6803, 7702, 7703, 7704, 7600

Figure 14: Detailed plan of Trenches 82, 90 and 101-2

Figure 15: Sections 9000, 9001, 9002, 10100, 10203, 10204 and 10205

Figure 16: Detailed plan of Trenches 91-4

Figure 17: Sections 9101, 9201, 9204, 9206, 9301, 9302, 9402, 9403

Figure 18: Detailed plan of Trenches 99, 103 and 104

Figure 19: Sections 9902, 9500, 10304, 10405

Figure 20: Detailed plan of Trenches 100, 105 and 109

Figure 21: Sections 10000, 10002, 10500, 10901

Figure 22: Detailed plan of Trenches 89, 96-8 and 107

Figure 23: Sections 9600, 9703, 10706, 10707, 10705/10708

Figure 24: Detailed plan of Trenches 120, 126 and 127

Figure 25: Sections 12001, 12702

Figure 26: Detailed plan of Trenches 138, 139 and 141

Figure 27: Sections 13803, 13901, 13903, 14101

Figure 28: Detailed plan of Trenches 140 and 162-8

Figure 29: Sections 16302, 16305, 16402, 16602, 16703

Figure 30: Detailed plan of Trenches 170 and 174-6

Figure 31: Sections 17400, 17503, 17504, 17505, 17600, 17602

Figure 32: Detailed plan of Trenches 149, 150 and 152

Figure 33: Sections 14900, 15000, 15001, 15203, 15204, 15205

Figure 34: Detailed plan of Trenches 178-9, 182-4 and 187

Figure 35: Sections 17801, 17802, 17902, 18300, 18406

Figure 36: Detailed plan of Trenches 151, 180-1, 185-6, 190-1 and 196

Figure 37: Sections 15101, 18001, 18004, 18502, 18507, 18602, 18606, 19103, 19104

Figure 38: Detailed plan of Trenches 194, 197-8 and 202

Figure 39: Detailed plan of Trenches 159, 161, 207-8 and 213

Figure 40: Detailed plan of Trenches 223, 226 and 216

Figure 41: Sections 16100, 19700, 19801, 20701, 21300, 21600, 22300

Figure 42: Detailed plan of Trenches 229-30 and 234-5

Figure 43: Sections 22900, 23002, 23402, 23404, 23401, 23500

Figure 44: Detailed plan of Trenches 237-43

Figure 45: Sections 23700, 23801, 24000, 24201, 24300

Figure 46: Geoarchaeological Transect 1: Trenches 5, 4 and 3

Figure 47: Geoarchaeological Transect 2: Trenches 7, 8, 9 and 10

Figure 48: Geoarchaeological Transect 3: Trenches 3, 11, 13, 15, 17, 21 and 25

Figure 49: Geoarchaeological Transect 4: Trenches 32, 31 and 33

Figure 50: Geoarchaeological Transect 5: Trenches 28, 26, 25 and 40

Figure 51: Geoarchaeological Transect 6: Trenches 50, 47 and 46

Figure 52: Geoarchaeological Transect 7: Trenches 90, 91, 92, 95, 96 and 97

Figure 53: Geoarchaeological Transect 8: Trenches 91 and 103 (AH denotes auger holes between trenches)

Figure 54: Geoarchaeological Transect 9: Trenches 110, 113, 115, 116, 117, 118, 120, 125, 129, 132 and 133

Figure 55: Geoarchaeological Transect 10: Trenches 122, 123, 127 and 133

Figure 56: Geoarchaeological Transect 11: Trenches 138, 139, 140, 162, 165, 169, 170 and 171

Figure 57: Geoarchaeological Transect 12: Trenches 140, 163, 166, 172 and 177

Figure 58: Geoarchaeological Transect 13: Trenches 170, 175, 179, 184 and 189

Figure 59: Geoarchaeological Transect 14: Trenches 141, 145, 146, 147, 148, 172, 177, 178, 179 and 181



## Plates

- Plate 1: Charcoal rich deposit 4005, looking west
- Plate 2: Pit 4205, looking north
- Plate 3: Pit 4903, looking north
- Plate 4: Ditch 6805, looking north-west
- Plate 5: Section 10100 showing intercutting features in Trench 101, looking south-east
- Plate 6: Possible ditch and pit at the base of Trench 82, looking north-east
- Plate 7: View across Trench 91 showing topography, colluvium and conditions looking east
- Plate 8: Pit 9415, looking south
- Plate 9: Pit 9404 with tufa block *in-situ*, looking east
- Plate 10: North-west facing section of Trench 103, showing deposits 10320, 10303 and 10302
- Plate 11: Trench 104 with the locations of surface flints flagged
- Plate 12: North-east facing section of Grid Square ACB, Trench 104
- Plate 13: East facing section of Grid Square EAA, Trench 97
- Plate 14: Pit 12706, looking south-west
- Plate 15: Pit 13813, looking north-west
- Plate 16: Possible pond in Trench 140, looking north-west
- Plate 17: Ditch 17516, looking south-east
- Plate 18: Sections 17504 and 17505, looking south
- Plate 19: Pit 17604, looking north
- Plate 20: Crouched inhumation 17615, looking south
- Plate 21: Pit 17807, looking east
- Plate 22: Ditch 19111, looking south-west
- Plate 23: Pit 15106, looking south
- Plate 24: Ditch 22903 with animal bones, looking south-west
- Plate 25: Pit 23414, looking south
- Plate 26: Ditch 23806, looking south-east
- Plate 27: Pleistocene sand and gravel deposits exposed in Trench 9

Plate 28: Colluvial sequence in Trench 4 (Valley C) with the remnant of a buried soil preserved at the base

Plate 29: Colluvial sequence in Trench 33 (Valley B) with the remnant of a buried soil preserved at the base

Plate 30: Colluvial sequence and peat deposits preserved in the base of Valley B in Trench 25

Plate 31: Radiocarbon dated late Glacial sequence and overlying prehistoric peat in Trench 95 (note the disturbance and burnt layer in the upper levels of the peat)

Plate 32: Monoliths from the prehistoric peat sampled for radiocarbon dating in Trench 91

Plate 33: Pleistocene sand and gravel exposed in Trench 133

Plate 34: Pleistocene sand and gravel exposed in Trench 184

## Tables

Table 1: Quantification and spot dates of Prehistoric pottery

Table 2: Quantification of late Iron Age and Roman fabrics (codes in brackets from Tomber and Dore 1998)

Table 3: Quantification by EVE of Roman pottery forms

Table 4: Description of post-Roman pottery by context

Table 5: Basic quantification of flint by land parcel

Table 6: Basic quantification of flint by simplified context type

Table 7: Basic quantification of flint by simplified context type and land parcel

Table 8: Flint from major lithic scatters in Land Parcel 7a

Table 9: Flint from cut features in Land Parcel 7a

Table 10: Flint from cut features in Land Parcel 7c

Table 11: Summary of fired clay assemblage

Table 12: Summary of fired clay by form

Table 13: Summary of CBM assemblage by number, weight, date, form and fabric

Table 14: Quantification of briquetage by context

Table 15: Metalwork assemblage

Table 16: Assessment of bulk samples

Table 17: Summary of skeletal samples

Table 18: Summary of charcoal identifications

Table 19: Details of the contexts sampled for waterlogged remains

Table 20: Assessed remains within the waterlogged samples

Table 21: Identifiable animal bone assemblage summary

Table 22 Radiocarbon sample details and calculated age ranges

Table 23: Results of paired  $\chi^2$  tests on peat samples from monolith 7 at 130-140mm

Table 24: Results of paired  $\chi^2$  tests on peat samples from monolith 7 at 320-330mm

Table 25: Results of paired  $\chi^2$  tests on peat samples from monolith 8 at 60-70mm

Table 26: Results of paired  $\chi^2$  tests on peat samples from monolith 8 at 280-290mm

Table 27: Results of paired  $\chi^2$  tests on peat samples from monolith 24 at 100-110mm

Table 28: Results of paired  $\chi^2$  tests on peat samples from monolith 116 at 240-250mm

Table 29: Summary of geoarchaeological profiles

Table 30: Geoarchaeological transect locations

Table 31: Summary of geoarchaeological samples

## Summary

---

Oxford Cotswold Archaeology was commissioned by Balfour Beatty to undertake a trial trench evaluation of land parcels 6, 7 and 8 covered by WSI Q of the Lower Thames Crossing Pre-Enabling Works. These land parcels are located directly west of Linford with the county of Essex and Thurrock unitary authority (NGR 566625 179242). A total of 224 trenches were dug and recorded between 13th July and 18th October 2021.

The evaluation recorded a variety of archaeological activity, with the earliest evidence represented by at least two possible late Upper Palaeolithic flint blades. These were recovered from amongst a much more substantial assemblage of later Mesolithic flint artefacts that were identified as surface scatters across Trenches 97, 98, 99, 103, 104, 105, 107, 109 and 113, in the fills of tree-throw holes and natural features in Trenches 138, 139 and 141 and residually in features in Trenches 176 and 234 further east. Mesolithic activity was concentrated towards the base of the valley, most clearly in Land Parcel 7a, but also extending eastwards across Land Parcel 7b and the north ends of Land Parcels 7c and 8. Together these indicate an occupation area of regional importance.

It is possible that an element of the extensive flint scatters may prove to be of early Neolithic date, as the flint technology is very similar, but no diagnostic pieces of this date have yet been found in association with them. Evidence for early Neolithic activity was otherwise indicated by a small number of features and deposits bearing either flintwork or pottery of possible early Neolithic date. These were widely dispersed across the site and tended to occur without any clear focus. This pattern continued into the later Neolithic and early Bronze Age with the recovery of occasional flintwork and a single sherd of possible Beaker pottery recovered from a later feature.

No certainly middle Bronze Age features or finds were identified, although several undated concentrations of charcoal and burnt flint were found that may represent burnt mounds, which are typically of middle or late Bronze Age date. A small number of features dated to the late Bronze Age were recorded including a pit in Land Parcel 6 which produced a large assemblage of pottery and numerous fragments of briquetage. Activity that is more likely of late Bronze Age than early Iron Age date was concentrated in the western part of the site. The main focus of Iron Age settlement, in contrast, was in the east of the site across Land Parcels 7c, where a number of trenches revealed a concentration of pits, ditches and postholes that continued and developed into the middle Iron Age, extending into Land Parcel 8.

Pottery of late Iron Age/early Roman fabrics tended to be associated with definitely early Roman pottery, making identification of a separate late Iron Age phase uncertain. In the early Roman period, activity was concentrated in Land Parcel 8, overlapping with the area of Iron Age settlement. A perforated kiln plate indicates the presence of a kiln nearby. Ditches of early Roman date followed two predominant orientations, suggesting a field or enclosure system, and these also mirror the lines of some Iron Age ditches, suggesting a degree of continuity of field or enclosure boundaries. The proximity of the Roman activity to the cropmark enclosure just east of the evaluated part of Land Parcel 8 may indicate that the enclosure was also of Roman date.

Early to middle Anglo-Saxon evidence was limited to two sherds of pottery from a pit in the northern part of Land Parcel 6. Several undated features were recorded in the

vicinity including a rectangular enclosure previously identified as a cropmark, which may indicate a broader focus of activity contemporary with the pit. A little distance to the south-east was a ditch dating to the Saxo-Norman period.

In the centre of Land Parcel 7a, and extending across several trenches in the valley bottom, was a spread of pits dating from the 11th to 13th centuries. Although no structural evidence was directly associated with these, the assemblage of pottery and environmental remains suggest a domestic setting and perhaps the presence of a farmstead. It is possible that the double-ditched enclosure evident as a cropmark just to the north of these, which was confirmed but not dated by the evaluation, was a stock enclosure associated with this domestic activity.

Several post-medieval boundary ditches were located by the evaluation, some also marked on historic maps. Among other undated features was a crouched inhumation recorded in Trench 176, which contained residual finds of prehistoric pottery and flint, but for which insufficient collagen remained to obtain a radiocarbon date. Although crouched burials are found at several periods in prehistory and into the early Roman period, the burial is most likely to be later Bronze Age or Iron Age in date.

## Acknowledgements

---

Oxford Cotswold Archaeology would like to thank the client, Balfour Beatty, for commissioning this project and managing the site safety and attendances. Thanks are also extended to the Historic Environment Consultant (Richard Havis) of Place Services at Essex County Council, who advises the Borough of Thurrock, for monitoring and providing advice throughout the project.

The project was managed for Oxford Cotswold Archaeology by Steve Lawrence and the fieldwork was directed by Mark Dodd. The fieldwork in Land Parcel 6 was supervised by Tom Bruce and Dan Firth, Land Parcel 7a/b by Eilidh Barr and Kat Whitehouse, Land Parcel 7c by Tara Schug and Nat Pacholek and Land Parcel 8 was supervised by Joan Roig. They were supported by Adrienne Morris, Agata Kowalska, Alessandra Rossi, Alex Capon, Alex Foley, Anna Lound, Ashley Joynes, Ashley Pooley, Benjamin Massey, Bevan Cope, Chloe Groves, Chris Griffiths, Christof Heistermann, Christopher Smallwood, Ciar Boyle Gifford, Dominic Allen, Elodie Powell, Georgina Matthews, Graeme Botham, Greg Bowen, Harlie Mason, Harry Mixer, Heather Beckitt, Heloise Meziani, Holly Owen, Holly Wright, Jack Easen, James McCallum, Jessica Domiczew, Joseph Smith, Kamil Prus, Kerree Foster, Lily Andrews, Mar Roige Oliver, Marionna Sandin-Catacora, Mel Harvell, Nathan Griggs, Richard Spencer, Rose Britton, Sam Oxley, Sharon Martin, Sian Bramble, Stephen Foster, Tanja Peter and Tom Hayes. Site survey was undertaken by Caroline Souday and Elodie Powell and digitising was carried out by Caroline Souday, Charles Rousseaux and Sophie Lamb. Thanks are also extended to the teams of OA staff that cleaned and packaged the finds and processed the environmental remains under the management of Natasha Dodwell and Rebecca Nicholson, and prepared the archive under the management of Nicola Scott.

# 1 Introduction

---

## 1.1 Project details and scope of work

- 1.1.1 The Lower Thames Crossing Project is located between the A2 in Kent and the M25 in the London Borough of Havering. It will run underneath the River Thames through a tunnel and emerge on the northern side of the river at East Tilbury. From the North Portal the road will run to the M25 at Junction 29 via the A13 and pass between North and South Ockendon. The development of the project is managed by LTC, a partnership between Highways England and a consultancy joint venture set up to oversee the scheme.
- 1.1.2 A programme of archaeological trial trenching commenced in the Essex part of the scheme in November 2019. A scheme-wide specification for trial trenching was written by LTC (Highways England 2018), and in July 2019, LTC commissioned Balfour Beatty to deliver the pre-Enabling Works. Balfour Beatty appointed Oxford Archaeology (OA) to prepare a project-wide written scheme of investigation (WSI) for the scheme, which (at the request of the key archaeological stakeholders) is divided into two parts, one for the Kent section, and another for Essex and Havering (Oxford Archaeology 2020a; 2020b).
- 1.1.3 Following completion of the project-wide WSIs, OA was instructed to prepare a series of site-specific or group-site specific WSIs for approval by the key archaeological stakeholders in advance of trial trenching to inform the Development Consent Order (DCO). A detailed WSI was created for Land Parcels 6-8 and 131-134 prior to the trial trenching (WSI Q, Oxford Archaeology 2021), which details the archaeological background and potential within the site. It also sets out the archaeological aims and objectives appropriate to the investigation of this land parcel group by trenching and describes the methodology to be applied. The WSI was approved by Richard Havis, Principal Historic Environment Consultant for Place Services at Essex County Council, prior to the start of the fieldwork. Oxford Cotswold Archaeology was commissioned as Balfour Beatty's archaeological contractor to undertake the evaluation fieldwork in accordance with the approved WSI and local and national planning policies.
- 1.1.4 The fieldwork in Land Parcels 6-8 was completed between 13th July and 18th October 2021. To date, no trial trenching has been undertaken in Land Parcels 131-134. All work followed the MoRPHE Project Manager's guide (Historic England 2015), and the Code of Conduct of the Chartered Institute for Archaeologists (CIfA). The archaeological works adhered to the standards and guidance for archaeological evaluation, excavation and archiving (CIfA 2014a; CIFA 2014b).
- 1.1.5 The work was monitored by Richard Havis of Place Services on behalf of the Borough of Thurrock.

## 1.2 Location, topography and geology

- 1.2.1 The area covered by WSI Q, comprising Land Parcels 6-8 and 131-134 (hereafter the site) is located directly west of the village of Linford (Fig. 1) within the county of Essex and Thurrock unitary authority (NGR 566625,



179242). The site comprises is an asymmetrical polygon with several projecting areas to the north-east, and covers an area of 115.15ha. This site is bounded to the west by the Hoford Road and also by agricultural fields, to the south by the Muckingford Road, to the east by Linford and to the north-east by agricultural fields and the Tarmac Building Products works. There is one small farm (Becksland) within the south-western part of the site, located 300m north of Muckingford Road.

- 1.2.2 The bedrock geology of WSI Q is mostly Thanet Formation (sand) with limited areas of Lambeth Group (sand, silt and clay) along the north-eastern edge of the site (OA 2021, fig. 2). The superficial geology of the land parcel is mixed, with a central swathe of the site containing Head deposits (clay, silt, sand and gravel) overlain down the centre by alluvium in the area of an east-west brook. Along much of the eastern edge of the site (parts of Land Parcels 7 and 8) the Thanet Sand is capped by Taplow Gravels, and at one point on the west (in Land Parcel 7) the site extends onto the Boyn Hill Gravel (sand and gravel) capping the Thanet Sand.
- 1.2.3 The north-western, western and southern parts of the site are currently arable fields. The central part of the site contains a pond and the course of a former brook that is aligned roughly east-west and is lined with trees. To the north and north-east of this is a further open field and larger areas of scrub land. The north-eastern part of the site is partly occupied by the Tarmac building products works.
- 1.2.4 This site is situated across a substantial dry valley which runs east-south-east through the gravel terraces to either side. Several smaller dry valleys also feed into this major valley from the north-east, and it is within these valleys that the Head and alluvial deposits have accumulated. The majority of the site is located on the slopes and in the bottom of these dry valleys. The highest ground within the site is at the north-eastern edge of Land Parcel 7, where the edge of the terrace reaches a height of c 25m aOD. The lowest part of the site is along the course of the brook in the centre of the site at c 6mOD. The dry valley deepens beyond the east edge of the site and continues north-east to the Mucking marshes and the River Thames.

### **1.3 Previous investigations**

- 1.3.1 The archaeological background and chronological summary given below is largely reproduced from the WSI (OA 2021.)
- 1.3.2 In 1955, the Ministry of Works and the Thurrock History Society conducted six weeks of rescue excavations at Linford, within the north-eastern part of the site. The excavations took place prior to large scale gravel extraction (Barton 1962, 57-104). The excavations recorded Iron Age, Roman and Saxon settlements. All three of these sites have since been destroyed by gravel extraction.
- 1.3.3 In 1974, an excavation was conducted by T W Potter (on behalf of the DoE) in the vicinity of the north-western part of the site. The excavation recorded four clusters of Iron Age pits/postholes which formed a rectilinear arrangement c 2.90m apart. The rectilinear feature was aligned NW-SE and was interpreted as an early to middle Iron Age raised granary. This site may have been located

just east of Rainbow Woods in an area which was subjected to gravel extraction in the later 20th century.

- 1.3.4 A multiperiod site was excavated at Mucking between 1965-1978 adjacent to Land Parcel 132. This extensive 18.2ha site was identified initially from extensive cropmarks showing on the gravel terrace overlooking the River Thames and was excavated prior to gravel extraction. The excavations identified finds and/or features of every period from the Mesolithic to the post-medieval periods. Of particular significance were two late Bronze Age ringforts, a highly organised landscape of the Roman period and an extensive settlement and two cemeteries of the Saxon period. Publications have been produced on the prehistoric (Bond 1988, Appleby, Evans *et al.* 2016), Roman (Lucy and Evans 2016) and Saxon phases of the archaeology (Hamerow 1993).
- 1.3.5 The Hordon to Coalhouse Gas Pipeline was located within the south-eastern edge of the site. A handful of worked flints were recorded as part of this scheme within the south-eastern part of site.
- 1.3.6 In 2004 an evaluation by Oxford Archaeology was undertaken just beyond the south-eastern limits of the site straddling Muckingford Road just west of Linford. This evaluation identified a handful of Bronze Age features and Roman agriculture ditches within the south-eastern part of the site. The evaluation was followed by an excavation located c 300m south-east of the site.
- 1.3.7 In 2010 a photographic survey and evaluation was undertaken at Mill House Farm located 0.6km west of the site. A number of cropmarks were recorded in this area prior to the evaluation and these were targeted by the trial trenching. The evaluation and excavation (forthcoming report) recorded an extensive late Bronze Age/early Iron Age settlement site with an associated funerary monument and an extensive Saxon settlement (Schofield 2010; Place Services 2019, 11).
- 1.3.8 An evaluation of the land immediately west of the site (LTC Land Parcel 5) was carried out for the scheme early in 2020 (OCA 2020a). Two separate Mesolithic microliths were found immediately adjacent to Land Parcel 6 of WSI Q. A Beaker pit was found in the west part of the land parcel and two lines of intercutting pits on the south-east edge were radiocarbon-dated to the early Bronze Age. A cropmark U-shaped enclosure at the east end produced pottery of the middle and late Bronze Age, and a cremation of late Bronze Age date was found 125m further to the west. Features containing late Bronze Age or early Iron Age pottery were scattered across the eastern half of the site while colluvial deposits and occasional features containing pottery of similar date were found all along the dry valley on the north-east edge of Land Parcel 5. A concentration of features containing a mix of prehistoric and Roman pottery was found in the very north-east corner, again adjacent to the site.
- 1.3.9 An evaluation of WSI I (including Land Parcels 9, 10 and 36) that lies immediately south of the site was also carried out for LTC in 2020 (OCA 2021a). An assemblage of Mesolithic/Neolithic blade-based flints, residual in layer 3703, was recorded in Trench 87 within the northern part of the evaluation. At the eastern edge of the evaluation area a ditch was recorded in Trench 240 which contained a small amount of early Neolithic pottery and

flints. Colluvium at the north-west edge of the evaluation (Trench 222) contained fresh Neolithic flintwork and pottery potentially of early Neolithic date.

- 1.3.10 Two cropmark features in the centre of the WSI I evaluation were targeted, including a sub-rectangular enclosure with an associated field system, and a circular smaller enclosure adjacent on the west. These features were located 350m south of the site. Two unurned cremation pits were found within the area enclosed by the curvilinear ditch, and although not dated, may well indicate a small Bronze Age barrow or flat cemetery. Within the sub-rectangular enclosure, a later Bronze Age or early Iron Age complete ceramic vessel was placed upright in a pit. The enclosure ditches were not securely dated as they contained small sherds of late Iron Age/early Roman and possibly early medieval pottery. Middle to later Bronze Age pits were also found within the central and northern part of the evaluation, with several containing hearths, oven furniture and charred plant remains. Small amounts of pottery of later Bronze Age or early Iron Age date came from several other pits and small ditches in the northern and eastern parts of the evaluation.
- 1.3.11 Two ditches located in the central part of the evaluation and one ditch in the north-western area contained small, abraded quantities of late Iron Age/Roman pottery indicated very limited Roman activity. Two isolated medieval pits, one containing pottery the other a horseshoe, were found in the southern and eastern parts of the evaluation. A boundary ditch and two very large pits, probably indicating quarries, all containing Tudor pottery and 16th - 18th century CBM, were revealed at the very south end of the evaluation adjacent to the hamlet of Low Street.

## 1.4 Archaeological and historical background

- 1.4.1 The chronological summary of known archaeology given below is taken from the detailed WSI for Land Parcels 6-8.
- 1.4.2 **Palaeolithic.** A large number of Palaeolithic finds have been recorded c 500m west of the site. This includes 115 handaxes, two roughouts and six flakes that were found within in an area of Boyn Hill Gravel.
- 1.4.3 Palaeolithic implements and flakes were found in a gravel pit at Mucking in the 19th century. The exact location of these finds is unknown as they are only recorded as a four-figure grid reference by the HER.
- 1.4.4 **Mesolithic.** Two Mesolithic microliths were found along the north-east edge of Land Parcel 5 just west of the site and a sparse scatter of struck flint of either Mesolithic or early Neolithic date more widely in the east part of Land Parcel 5. Several clusters of worked flints were located at the northern and eastern sides of the LTC5 evaluation, just west of the site and on lower lying ground close to the base of a dry valley, and perhaps therefore suggest late Mesolithic activity alongside a former watercourse. Residual Mesolithic/ Neolithic blade-based flints were also found 80m south of the site in Trench 87 during the WSI I evaluation.
- 1.4.5 A small number of Mesolithic finds were identified during the Mucking excavations just north-east of the site but these may have been residual.
- 1.4.6 Mesolithic find spots have also been recorded 1-1.5km west of the site.

- 1.4.7 **Neolithic.** A Mesolithic or Neolithic flint macehead axe and a Neolithic axehead have been recorded within the central part of the site.
- 1.4.8 During the LTC6 evaluation fresh Neolithic flintwork was recorded in Trench 222 located 120m south-west of the site. Early Neolithic pottery and flints were also recorded in Trench 240 located 400m south-east of the site.
- 1.4.9 A scheduled early Neolithic causewayed enclosure (SM 10092867 Aerial Mapping Report site 17A) is located 0.6km north-west of the site. This was excavated in 1975 the pottery found within the causewayed enclosure was of Mildenhall type dating to the early Neolithic along with flints of the same date. The secondary ditch silts of the enclosure also contained a small quantity of late Neolithic/early Bronze Age pottery (Hedges and Buckley 1978, 219-308).
- 1.4.10 During excavations at Mucking a number of Neolithic pits were found c 200-400m north-east of the site. These contained worked flints and pottery sherds. The pottery indicated that there were several phases of material including an early Neolithic phase with Mildenhall pottery sherds and a later Neolithic Grooved Ware phase. A beaker burial was also recorded and a domestic assemblage of Beaker pottery.
- 1.4.11 During the 2004 evaluation west of Linford a single piece of Beaker pottery (late Neolithic/early Bronze Age) was found within Trench 176 located in the south-eastern part of the site. The pottery was found within a NE-SW aligned ditch and may have been residual (Oxford Archaeology 2005).
- 1.4.12 Several Neolithic axeheads have historically been found in the vicinity of the site, but the exact location of these finds is unknown as they are only recorded as a four-figure grid reference by the HER.
- 1.4.13 **Early to middle Bronze Age.** There is extensive archaeological and cropmark evidence for an early to middle Bronze Age ring ditches, barrows and cremation cemeteries within the study area. These appear to be concentrated on the higher ground and the slopes of the terrace.
- 1.4.14 During the Mucking excavations, eight barrows were recorded c 0.5-0.8km north-east of the site and these were dated to c 1700-1400 cal. BC (middle Bronze Age). The barrows were 4.25-14m diameter and were mostly associated with inhumation burials (Lucy and Evans 2016, 5-8).
- 1.4.15 Three barrows and a trackway were recorded c 150m south of the site. The central double ditched barrow and largest of the three was excavated in 1959-60 (Bannister 1961; 1962). The inner and outer ditch were found but no trace of a mound, which may have been obliterated by ploughing. Human cremated bone and a few small pieces of pottery were recorded in the ditches. A cylindrical cairn or cist of large pebbles was found in the centre of the barrow and it contained an inverted urn over a saddle quern. The urn contained the calcined bone of an adult and a child and a faience bead and metalwork. The cremated bone was radiocarbon dated to 1740-1610 cal BC (GrA28939; 3365±40 BP) (Sheridan 2008, 58). This dates the barrow to the end of the early Bronze Age (or just possible the start of the middle Bronze Age). Two smaller ring ditches located adjacent to the larger barrow were identified as cropmarks in 1980, although one of these was incomplete. A curved trackway was also located next to the ring ditches.

- 1.4.16 The Hordon to Coalhouse Gas Pipeline scheme passed through the south-eastern of the site and continued further south on a NW-SE alignment. A cremation cemetery was identified c 150m south of the site and close to the large barrow (Smoothy 1993). Four urned and two un-urned cremations were recorded and one of these was recorded within a pit lined with flints, similar to the cairn within the double ring ditch. Pottery from three of the urns was dated to the middle Bronze Age and the fourth possibly to the early Bronze Age, although this urn was very fragmentary. One piece of unburnt human bone was also recorded, suggesting that an inhumation burial was formerly present. These cremations could be associated within the nearby Bronze Age barrow. The aerial survey identified a number of possible pits south of the large ring ditch, which might also be related to the cremation cemetery (Aerial Mapping Report site 40A).
- 1.4.17 Two large adjacent circular or penannular ring ditches, located 0.3km west of the site, are visible on aerial photographs (Aerial Mapping Report site 26). These ring ditches, which are approaching 40m across, may be large Bronze Age barrows, or possibly earlier prehistoric monuments. Further cropmarks of ring ditches in the vicinity are located east and west of Blue Anchor Lane and Hoford Road within the western part of the study area. Cropmarks of a possible ring ditch, linear features and pits were also recorded 0.6km north-west of the site (Aerial Investigations and Mapping Report site 24A). These sites are part of a wider extensive area of cropmarks (Aerial Mapping Report sites 53, 24B, 73, 74 and 26) which are located along the edge of the dry valley between Chadwell St Mary and Linford.
- 1.4.18 During evaluation for the scheme in 2020, a possible ring ditch located 200m west of the site was confirmed by Trench 84 of the LTC5 evaluation, although the fills of the ditch produced no dating evidence. A Beaker pit was found 500m west of the west end of the site, and 250m south of the very west end of the site, two parallel lines of intercutting pits or tree-throw holes were found and were radiocarbon-dated to the early Bronze Age (OCA 2020a).
- 1.4.19 In 2014 an excavation was undertaken at Bata Fields located c 300m south-east of the site. The excavation identified a late Neolithic/early Bronze Age (c 2500-1700 BC) double enclosure consisting of a sub-square annular ditch with a sub-rectangular annexe attached to the west side, together measuring 11m x 15m. A single cremation was found within the sub-rectangular enclosure and was dated to 1750-1530 cal. BC (Oxford Archaeology 2016). The radiocarbon date from the enclosure is similar to that from the cremated bone from the barrow, i.e. the end of the early Bronze Age or the start of the middle Bronze Age. The excavation also located three larger enclosures, two of which produced middle Bronze Age finds, the third middle-late Bronze Age pottery and other finds. The enclosures were also associated with trackways, a trampled surface and a six-post building. One of the enclosures contained three small circular ditches (perhaps representing roundhouse gullies). Unaccompanied cremations were found in the north-west part of the excavation area (closest to the site), but these may have been of later date.
- 1.4.20 The Hordon to Coalhouse Gas Pipeline also identified a number of worked flints along the route and some of these were found within the south-eastern

and north-eastern part of the site. These flints were not specifically dated in the HER.

- 1.4.21 The Essex HER records that four bronze torcs and a bronze pin were found in parish of Orsett and these objects were presented to the Victoria and Albert Museum in 1901. The exact site where these objects were found is unknown but it does suggest the possibility of high status Bronze Age finds.
- 1.4.22 **Later Bronze Age and Iron Age.** The cropmarks of a possible trackway including two widely spaced parallel ditches aligned NE-SW are located partially within the north-western part of the site. This trackway appears to be truncated by a rectangular enclosure (Aerial Investigations and Aerial Mapping Report site 79). It is possible that this trackway could be of later prehistoric date.
- 1.4.23 Cropmarks have been recorded 300m west of the site including linear features and an extensive number of pits (Aerial Investigations and Mapping Report site 24A). These fields were evaluated for the LTC scheme in 2020, and many of the pits were tested and were found to be variations in the gravel or sand and silt content of the geology and were clearly not of archaeological origin. The evaluation also investigated a cropmark U-shaped enclosure only 125 m from the site, which was dated to the middle and late Bronze Age, and a cremation accompanied by late Bronze Age pottery was found 125m further west. Scattered features containing pottery of late Bronze Age or earlier Iron Age pottery were found across the two fields closest to the site, with pottery of the same date in colluvial deposits all along the dry valley on the north bordering the site (OCA 2020a).
- 1.4.24 The 2019 aerial survey recorded a rectilinear enclosure, circular feature and possible trackway located 350m south of the site (Aerial Investigations and Mapping Report site 41A). The rectilinear enclosure was targeted during the LTC trial trench evaluation of Land Parcel 9 in the area of WSI I (OCA 2021a). Within the enclosure a later Bronze Age or early Iron Age complete ceramic vessel was placed upright in a pit, which was confirmed as late Bronze Age by radiocarbon dating to 1110-890 cal BC at 95% confidence. This may indicate that the enclosure also dates to this period, but this is uncertain as only two small sherds of late Iron Age/Roman and possibly Saxon pottery were found within the enclosure ditches. This enclosure is also discussed below as being of possible Roman date.
- 1.4.25 The smaller circular enclosure adjacent did not produce any dating evidence, but two unurned cremation pits were found in its interior, and these may have formed part of a small Bronze Age enclosed flat cemetery.
- 1.4.26 The evaluation of Land Parcels 9, 10 and 36 also found later prehistoric pits within the central and northern part of the evaluation. These were generally widely dispersed although a small cluster was evident 600m south of the WSI Q site.
- 1.4.27 At Mucking a Springfield Type enclosure was excavated 0.4km north-west of the site and this was dated to the late Bronze Age. This enclosure was 75m diameter and comprised two concentric ditches and a bank probably topped by a palisade. The enclosure had two opposing entrances with gate structures and internal buildings. The enclosure was surrounded by a later Bronze Age

settlement. The finds indicated a partly pastoral economy and also metalworking and salt making activity. The structure may have been partly defensive, and it also had evidence for mass gatherings in its final use. During the Iron Age the settlement area expanded and intensified with several enclosures surrounded by a large number of roundhouses located c 300-1km north-east of the site. Several inhumation and cremation cemeteries of Iron Age date were also recorded (Lucy and Evans 2016, 5-8).

- 1.4.28 In 2014 an evaluation was undertaken on land near Walton Hall Farm located 0.7km north-east of the site. This evaluation found a number of undated and late Bronze Age features on the slopes of the terrace including ditches and gullies, trackways postholes and a possible ring ditch. It was noted that there were less archaeological features on the slope of the terrace compared with the terrace itself to the north-west.
- 1.4.29 In 2010 an evaluation was undertaken at Mill House Farm located 0.6km west of the site. A number of cropmarks were recorded in this area prior to the evaluation and these were targeted by the trial trenching. The evaluation recorded a number of enclosure ditches, pits, postholes, gullies and ring ditches. Pottery (94 sherds) was found within several ditches, a pit and the ring ditch dating to the late Bronze Age/early Iron Age. This site was interpreted as a late Bronze Age/early Iron Age enclosure settlement with an associated funerary monument (Schofield 2010). This site has subsequently been excavated but is not yet published. The interim results of the excavation include a dense site of late Iron Age date with a number of enclosures, cremations, ring ditches, smelting pits and over 8000 sherds of pottery (Andy Peachy pers comm.).
- 1.4.30 An extensive area of cropmarks were also identified c 200m west of the site and east of Mill House Farm by the aerial survey just north of the Muckingford Road (Aerial Investigations and Mapping Report site 24B). This site includes linear features, ring ditches, pennanular ditches and pits (Aerial Investigations and Mapping Report site 26). It appears possible that the extensive cropmarks just west of the site may represent features of a similar date to those found at the nearby Mill House Farm, i.e. late Bronze Age/early Iron Age or of Saxon date (see below).
- 1.4.31 The excavation of the Bronze Age barrow located c 150m south of the site also found remains of levelling and later occupation deposits containing pottery, burnt clay and wood. The pottery was thought to date to the Iron Age. The aerial survey identified a linear feature projecting south-east of the concentric barrow and it is possible that this feature could indicate a later use of the barrow as a marker during the Iron Age (Aerial Mapping Report site 40A).
- 1.4.32 The Neolithic causewayed enclosure located 0.8km north-west of the site was overlain by an unenclosed early Iron Age site and a middle Iron Age sub-rectangular enclosure (Hedges and Buckley 1978, 219-308). Cropmarks including pits, linears and ring ditches extend from the area of the scheduled early Iron Age enclosure (Aerial Mapping Report sites 17A, 17B and 72). Additional cropmarks are recorded by the HER extending further east and 0.5km north of the site including trackways and linear features and some of

these were mapped by the aerial survey (Aerial Investigations and Aerial Mapping Report site 19A).

- 1.4.33 A small Iron Age settlement was identified by excavation in 1955 within a gravel quarry within the north-eastern part of the site. The Iron Age features recorded were pits, hearths and a possible hut. Several hearths were recorded that including surface hearths and several pottery kilns. The pottery kilns were lined with clay and the fills contained charcoal and pottery fragments. The pottery within these features dated to the early Iron Age (Barton 1962, 57-104). Early to middle Iron Age features were also recorded in Rainbow Wood in the 1970s just north of the site and these may have been part of the Iron Age settlement recorded nearby. The excavation recorded four clusters of Iron Age pits/postholes which formed a rectilinear arrangement which was interpreted as an early to middle Iron Age raised granary (Potter 1974, 1-12).
- 1.4.34 The 2021 LiDAR analysis of the site identified a bank aligned NE-SW with a ditch either side in the north-western part of the site. These features follow the topography of a promontory and are part way up a slope. The promontory is located at the intersection of two dry valleys and defines the plateau on which the multiperiod site of Mucking is situated c 400m north-east of the site. The bank terminates at another east-west bank within the site which can also be seen on the LiDAR, and this may be later in date (see discussion below). The NE-SW aligned ditch above the bank continues south-eastward and is roughly defined by the south-western boundary of Rainbow Wood. Intriguingly, if the line of this ditch is followed south-eastwards it matches a linear feature associated with a rectangular cropmark enclosure which is located within the northern part of the site (Aerial Investigations and Mapping Report site 24A; Fig. 5). The ditch may post-date the enclosure or may be contemporary with it. This enclosure is located on a low rise of ground projecting southwards from the promontory. It is possible that the enclosure and series of banks and ditches are later prehistoric in date (perhaps Iron Age) and define the edge of a promontory as part of a wider territory including Mucking to the north-east. The banks and ditches may have become fossilised in the landscape and later became part of the late Saxon manors/medieval parishes of Mucking and West Tilbury (discussed below). Alternatively, they may represent later boundaries.
- 1.4.35 The 2019 aerial photographic analysis by Place Services identified a possible enclosure and two parallel linear features within the north-western part of the site (Place Services 2019, AP79;). These features are located at the southern edge of a small promontory overlooking the dry valley to the south. The possible enclosure may be of later prehistoric or Roman date. It is possible this feature may have been deliberately placed at the edge of the promontory. The eastern linear feature appears to match a field boundary on the tithe map of 1845 (not illustrated) and may be unrelated to the possible enclosure. This possible enclosure is located in close proximity to a platform which was observed during the LTC walkover of the site. This feature was located on top of ridge in undulating landscape and did not appear natural. It is possible that enclosure and platform were at the same location although they have been mapped in slightly different areas.



- 1.4.36 The 2021 aerial photographic analysis by Place Services identified a number of additional features just north-west of the site, and some of these may extend southwards into the site itself. These new features include two parallel possible trackways aligned NNE-SSW with a rectilinear enclosure between them. The trackway ditches are 15-20m apart. One of the trackways running towards the dry valley in the north-western part of the site and may have continued SSW through the site using the dry valley as an extension to the trackway. The rectilinear enclosure between the two trackways is in alignment with the trackways and is equidistant from them. It is possible that the trackway and enclosure are of later prehistoric or Roman date. The OS map of 1897 shows that the trackways are on the same alignment as the western edge of Mucking Heath woods, and the woodland may have fossilised the earlier trackway alignment. Alternatively, the trackway may be of medieval or post-medieval date (see discussion below).
- 1.4.37 **Roman period.** The route of a possible Roman road is projected to run along the Muckingford Road and directly south of the site. The route of another possible Roman road, now East Tilbury Road, is thought to bisect the eastern part of the site on a NW-SE alignment. Another Roman road is thought to have linked Brentwood with West Tilbury, located 1km west of the site. It is possible that additional Roman roads or trackways cut roughly east-west across the terrace. Several Roman sites have been identified either side of the East Tilbury Road within the study area including the large Mucking settlement complex and another kiln site located in the north-eastern part of the site. Several possible Roman sites have also been identified either side of Muckingford Road including a Roman enclosure within the site and a rectangular enclosure located 0.6km south of the site. Another enclosure is located within the site and just west of the Hoford Road.
- 1.4.38 A geophysical survey and subsequent archaeological evaluation recorded evidence of a Roman activity within the south-eastern part of the site (Oxford Archaeology 2005). This included a gravel surface and ditches orientated NW-SE and NE-SW. Two of the ditches in Trenches 175 and 181 may have represented a driveway. In addition, a possible gravel surface, pits and postholes were recorded in Trenches 178, 189 and 206 within the site and these may represent a roadway and part of a settlement. The pottery from these features indicated a date range starting in the 1st century and concentrating in the late 2nd and early 3rd centuries. The remains of charred grains and chaff identified in soil samples from features in Trenches 168 and 206 provide evidence for the processing of crops in this area (Oxford Archaeology 2005).
- 1.4.39 A rectilinear enclosure, a trackway and a number of pits are recorded within the south-eastern part of the site by the HER and the aerial mapping survey (Aerial Investigation and Mapping Report 39). The evidence from the 2005 evaluation has been compared with evidence from the aerial survey and Trenches 178 and 189 are located in the vicinity of the rectilinear enclosure. This suggests that this enclosure may be of 1st-3rd century AD date. The trackway associated with this enclosure extends north-eastwards within the site and is parallel with Muckingford Road and perpendicular to the East Tilbury Road.

- 1.4.40 The cropmarks of an undated double ditched rectangular enclosure that is c 100m long and wide is located within the central part of the site. This enclosure appears to have an entrance on the southern and western side. Another rectangular feature is also located just to the south and a possible trackway to the north-west which is on a NW-SE alignment (Aerial Investigations and Aerial Mapping Report site 25). The trackway appears to be leading from Hoford Road which might suggest that this enclosure is contemporary with the road. The date of Hoford Road is unknown, it may have originated as a later prehistoric trackway, as a Roman road or as a medieval droveway.
- 1.4.41 A Roman settlement was excavated at Mucking located just east of the Orsett to East Tilbury Roman road and 0.3-1km north-east of the site. This extensive site demonstrated a continuity from the Iron Age settlement and comprised a series of large rectilinear enclosures with internal subdivisions. The site was used for pottery production from the 1st to the mid-3rd century AD and a number of kilns were excavated across the site. This site also contained five cemeteries. The settlement itself continued into the fifth centuries AD where it was remodelled as a Saxon settlement (Lucy and Evans 2016, Summary). Roman pottery has also been found to the south of the Mucking settlement and 0.5km east of the site. This pottery was found within a quarry on the slopes of the terrace near Walton Hall Farm and dated to the 1st-2nd century. Another possible square and rectangular enclosure was identified by cropmarks just to the south of this, located 0.3km east of the site (Aerial Investigations and Mapping Report site 67).
- 1.4.42 The Iron Age pottery site located within the north-eastern part of the site may have also been used during the Roman period. This site was located west of the East Tilbury Road and c 200m south-west of the Mucking site. The 1955 excavation of the gravel pit recorded that workers found six bottle neck shaped structures, cut into the gravel and lined with clay, that were full of pottery. It is possible that these structures, now destroyed, were late Iron Age or Roman pottery kilns. The 1955 excavation also found Roman pottery dating to the 2nd-4th century scattered over a wide area, suggesting a possible agricultural use for the this area in the Roman period (Barton 1962, 57-104).
- 1.4.43 A possible Roman site and a Roman findspot was recorded 0.6km south of the site and south of Muckingford Lane, the proposed east-west Roman road. The aerial mapping survey identified a NE-SW aligned rectangular enclosure and Roman pottery of 2nd century date was found within it (Aerial Investigations and Mapping Report site 41A), though not directly from the enclosure ditch. This could be associated with a nearby NW-SE linear feature to the west, possibly part of a trackway. The LTC6 evaluation targeted this enclosure and a one small sherd of late Iron Age/Roman pottery was found within the enclosure ditches. The dating of this feature was therefore not conclusive. Further undated enclosures and trackways have also been identified 1km south-east of the site and west of Low Street Road. A walkover of this area as part of the scheme in 2019 recorded a coarse and angular roof tile in this area, probably Roman in date (Aerial Investigations and Mapping Report site 41B, 43).
- 1.4.44 Two Roman findspots have been identified close to the route of the possible Roman road and 0.5km north-west of the land parcel. This includes a bronze

fibula dated c 100BC-60AD which was a residual find from a Saxon ditch and Roman pottery (possibly 1st century) that was found to the north of the site of Seaborough Hall.

- 1.4.45 A number of rectilinear enclosures and enclosure systems are visible as cropmarks along the east edge of a valley 0.1-1.5km north and north-east of the site (Aerial Mapping Report sites 25, 44 and 45). These may have been Roman rather than Iron Age or have continued in use in the Roman period.
- 1.4.46 Several copper coins of Carausius were found in 1906 approximately 0.8km west of the site but the exact location is unknown. Carausius reigned over Britain and Gaul from AD 286-293 and so although the exact location is unknown it does indicate later 3rd century Roman activity in this vicinity.
- 1.4.47 **Medieval period.** A substantial early Saxon settlement was also excavated at Mucking in the 1970s located just north-east of the site. Archaeological excavations revealed that an extensive Anglo-Saxon settlement was located at Mucking. The settlement comprised at least 53 posthole buildings and 203 sunken featured buildings and was occupied from the 5th to the 7th-century AD (Hamerow 1993). Evidence of metalworking and two contemporary cemeteries were also excavated. Another area of settlement has been excavated directly to the west (and west of the East Tilbury Road) and is probably a continuation. This settlement, which was excavated in 1955, was located within the north-eastern part of the site and was destroyed by later 20th century gravel extraction. The excavation revealed several enclosures and structures including a possible weaving hut with twenty loom weights. Some of the Saxon pottery had continental parallels and dated to the end of the fourth or fifth century (Barton 1962, 57-104). Previous studies have noted the similarity between the 5th-7th century Saxon material culture of Kent and south-east Essex (Hamerow 1993, 95), and it is almost certain that a trade network operated across the Thames, perhaps from East Tilbury. The settlement density at Mucking appears to have diminished in the middle Saxon period. Field systems recorded across the area indicate that the land subsequently reverted to agriculture.
- 1.4.48 Middle Saxon activity has been identified north-west of the site. The Orsett causewayed enclosure (1009286), located 0.8km north-west of the site was reused as a Saxon funerary monument in the 7th-8th century.
- 1.4.49 A series of sunken-featured buildings and other features of Saxon date were found at Mill House Farm located 0.6km west of the site, indicating a substantial settlement (Place Services 2019, 11). This site was excavated by Archaeological Solutions in 2014, but is not yet published.
- 1.4.50 The site is located within the medieval parishes of Mucking, West Tilbury and East Tilbury. These may have originated as Saxon manors although East and West Tilbury are listed as one manor in Domesday and may have been split later. Domesday notes that in 1086, East and West Tilbury had 16 householders within three different manors. The largest of these was owned by Swein of Essex in 1086, and this had 14 householders, six plough teams, pasture for 300 sheep, woodland and a fishery. The other two land holdings only had one householder each and were owned by William of Warenne and Theodric Pointel. In the late Saxon period, there were two manors in Mucking and both belonged to the abbey of St Mary in Barking. The largest settlement

had 37 householders, eleven plough teams, pasture for 300 sheep, woodland for 300 pigs, one mill and a fishery. The second manor only had three householders (Palmer 2019).

- 1.4.51 The medieval parish boundary between Mucking and West Tilbury bisects the north-western part of the site. This boundary appears to be defined by several banks and ditches that were evident on the LiDAR survey within the south-eastern part of the site. It is possible that the NE-SW aligned banks and ditches around the promontory may be later prehistoric in date as they align with a rectilinear enclosure within the northern part of the site. The east-west boundary bank, which truncates the NE-SW aligned bank, and one ditch of may be later in date. If not prehistoric, both sets of features may be medieval in date and have been constructed specifically to define a parish boundary.
- 1.4.52 In the later medieval period, it is likely the site was used as arable farmland. LiDAR analysis identified NE-SW aligned ridge and furrow just north of the north-western part of the site and this may extend into the site itself. A NE-SW aligned field boundary bank was recorded during the walkover within the north-western part of the site. This may have defined the eastern edge of a field of ridge and furrow within the dry valley.
- 1.4.53 During the later medieval period it is likely that there were settlements located in the vicinity of the churches of Mucking, West Tilbury and East Tilbury. The medieval church of Mucking was demolished and rebuilt in the 19th century and is located 1.6km north-east of the site (Essex Churches website 2019). The Church of St James in West Tilbury is Grade II\* listed and is located 950m south-west of the site. This church dates from the late 11th or early 12th century. Earthworks located west of this church have been scheduled and this may be the location of the medieval village of West Tilbury. The Church of St Margaret, now renamed as the Church of St Katherine in East Tilbury is located 2.5km south-east of the site. This church is Grade I listed and has elements dating to the 12th-13th century. It is also likely that there were number of farmsteads and houses located along major routeways in a dispersed settlement pattern. It is likely that the East Tilbury Road and Muckingford Road continued in use from the Roman and Saxon period. Walton's Hall Road is likely to have been in existence by the later medieval period and this road led from the East Tilbury Road to Mucking. The Grade II listed Sutton's Farm House is located just north of this road and dates from the late 16th century. In addition, the Hoford Road may have originated in this period or may have been far older.
- 1.4.54 The Map of Essex 1777 by John Chapman and Peter Andre may indicate the medieval road layout and settlement pattern in this area. This map shows Muckingford Road, the East Tilbury Road and the Hoford Road in the vicinity of the site. In addition, this map also shows that there were three trackways extending northwards from the Muckingford Road within the area of the site. These only extend for a short way apart from one which extended further to a building (in the area of the later Beckland (now Becksland) Farmhouse). It is possible that these trackways previously extended further. Satellite imagery and LiDAR data shows that there are two north-south aligned cropmarks within the south-western part of the site. One of these is in alignment with Low Street Lane which is of some antiquity. Another north-south to NE-SW

hedgerow also aligned with Hoford Road and the two cropmarks. It is possible that these linear features may be former droveways which may have been used to take livestock down to the marshes for grazing.

- 1.4.55 The site of the medieval to post-medieval manor of Seaborough Hall was located c 0.5m north-west of the site and west of Brentwood Road. This hall is first mentioned in the 13th century and it appears on the OS map of 1897. This manor house was demolished in the 20th century and all that remains is a wall adjacent to Brentwood Road (Thurrock Local History Society 2019).
- 1.4.56 **Post-medieval period.** Prior to the 20th century the road layout in the vicinity of the site remained the same as that shown on the Map of Essex 1777. A late 17th century Grade II listed building is located 0.2km east of the site, just west of Princess Margert Road (East Tilbury Road). A number of Grade II listed post-medieval buildings are located along Walton's Hall Lane including the 17th century Waltons Hall and barn and the 18th century Turners Farm. The nearest settlement to the site in the post-medieval period was the hamlet of Muckingford. The Map of Essex 1777 by John Chapman and Peter Andre shows that in the late 18th century this was located at the junction between the Muckingford Road and the East Tilbury Road.
- 1.4.57 During the post-medieval period the majority of the site was in use as arable fields associated with several manors in the parish of East Tilbury, West Tilbury and Mucking. The boundary between the parishes appears to have been formed along the line of a former brook, shown on the 1897 OS map and is now preserved as a pond and a line of trees.
- 1.4.58 The south-eastern part of the site (Land Parcel 8) was in arable use belonging East Tilbury. The 1839 tithe map of East Tilbury shows that this part of the site comprised several north-south aligned arable fields and osier beds located adjacent to the brook. Osier beds were willow plantations that were harvested make wicker baskets and fish traps etc. In addition, a cottage and garden were located within the site just north of the Muckingford Road as it turned 45 degrees north-eastwards towards the east Tilbury Road. This cottage was owned by Mary Driver and was occupied by Thomas Howell. This may be the same cottage that is shown on Map of Essex 1777 and the 1873 OS map at this location. Subsequent OS maps show several buildings at this location, perhaps a row of four small cottages. These cottages are shown on the OS maps until 1938 and were demolished soon after as they do not appear on the OS map of 1959.
- 1.4.59 The majority of the fields within western south-western part of the site (parts of Land Parcels 6 and 7) were in arable use as shown on the West Tilbury Tithe map of 1838. The majority of the field boundaries relating to these fields have been removed apart from the north-south aligned cropmarks and hedgerows (as discussed above) which may have originally marked the position of droveways. There was one farmstead at the south-western edge of the site and this was Beckland Farm and barn as shown on the 1838 tithe map. This may be the building shown on the Map of Essex 1777 and the 1873 OS map at this location. This post-medieval farm building and barn may still be extant within a modern farm at this location. There were also osier beds within the site along the southern side of the brook as with the area of the sit in East Tilbury.

- 1.4.60 The north-eastern part of the site in the parish of Mucking had a more mixed use than the other areas of the site. The 1845 Mucking Tithe map shows that this area contained parts of several arable fields and patches of woodland either side of the Hoford Road. There were also small pasture fields located just north of the brook. The extensive quarrying within this part of the site in the 20th century removed all of the historic field boundaries shown on the tithe map. There does not appear to have been any post-medieval farmhouses in this part of the site as shown on historic mapping.
- 1.4.61 **Modern.** In the 1880s plans were made to expand the hamlet of Muckingford and a number of roads were laid out within the eastern part of the site as part of the North Tilbury Dock Estate. A church was built in 1900 on the eastern side of the East Tilbury Road to serve this community. In the early 20th century the development of the estate slowed until East Tilbury Station was constructed in 1936. This station was built to serve the Bata shoe factory which became a major employer in the area. The estate became known as Linford as the name Muckingford was thought to be unglamorous (Linford Methodist Church, 2000 Linford's History).
- 1.4.62 During the Second World War a number of anti-invasion defences were set up in the study area including a road barrier on Muckingford Road and three Spigot Mortar positions. All of these are now destroyed.
- 1.4.63 In the later 20th century the north-eastern part of the site (Land Parcels 7 and 131) became part of an extensive gravel extraction site and concrete plant. The gravel extraction pits extended either side of Hoford Road. Hoford Road itself became downgraded to a green lane.
- 1.4.64 **Undated features.** As mentioned above the cropmarks of a double ditched rectangular enclosure is located within the central part of the site. This enclosure could be of later prehistoric or Roman date and is perhaps linked with the origin of Hoford Road. In addition, another undated feature, a possible trackway including two widely spaced parallel ditches and part of an enclosure are located within the north-western part of the site. This may also be of later prehistoric or Roman date.
- 1.4.65 The LTC walkover survey indicated that there may be several features within the north-western part of the site. This includes a NE-SW aligned gully in a fields of unknown date. It is possible that this feature is a drainage ditch as it matches the direction of slope in this area. In addition, a platform was recorded on top of a ridge nearby which did not appear to be a natural feature. This platform will perhaps be better understood after analysis of aerial photographs (forthcoming) as part of this scheme. Potentially this platform could be archaeological in nature but there was a large amount of quarrying in this area during the later 20th century and so further analysis is needed of this site. The north-western part of the site also contains several boundary banks and ditches and these features have been discussed in detail above.
- 1.4.66 In the wider 1km buffer there are a large number of undated cropmark sites located on the higher terrace towards the north-west of the study area. A large number of cropmarks have also been identified on the terrace to the south-west of the study area and east and west of Hoford Road and Blue Anchor Lane including a ring ditch, features near Gun Hill, another trackway and ditches. There is also evidence of cropmarks located east of the site. It is

probable that many of these undated cropmark sites will prove to date to the later prehistoric or Roman period.

## 2 Project Aims

---

### 2.1 General aims

2.1.1 The general aims of the project were as follows:

- i. To establish the presence or absence of archaeological remains along the line of the scheme, and the extent of any areas where remains appear likely to be absent.
- ii. In areas where archaeological remains are known or suspected, to clarify the reliability of the cropmark or geophysical survey evidence.
- iii. In areas where no archaeological remains are indicated by aerial or geophysical survey, to clarify whether this apparent absence of remains is genuine.
- iv. To determine the degree of complexity of any surviving horizontal or vertical stratigraphy, and in particular, to investigate areas where topography indicates the likelihood of deep deposit sequences for evidence of buried archaeological horizons and palaeo-environmental sequences.
- v. Where remains are present, to determine the period(s) represented, the extent, state of preservation and character of the archaeological remains.
- vi. To establish the range and state of preservation of archaeological artefacts, and through their recovery and examination, to establish the potential for information about the economy, status and contacts of past inhabitants of the scheme footprint.
- vii. To determine whether palaeo-environmental remains are preserved, and, where these are found, to determine their types (e.g. charred plant remains, waterlogged remains, molluscan remains), state of preservation and potential for environmental information. This will be achieved through the recovery of samples from sedimentary sequences and archaeological features suitable for assessment of a range of palaeoenvironmental remains (e.g. charred and waterlogged plant remains, charcoal, insects, pollen, diatoms, ostracods/foraminifera and molluscs) and scientific dating (e.g. radiocarbon and OSL dating).
- viii. To investigate and record the extent, character and chronology of the sedimentary sequences, in particular those immediately adjacent to and in floodplains, contained within palaeochannels or in dry valleys, and to use the data to refine existing geoarchaeological (predictive) deposit models.
- ix. To place any identified archaeological remains into their local and, where appropriate, regional or national context, and to assess the implications of any such discoveries for our current understanding of settlement and landscape change in the area, including an assessment of the associations of any remains with reference to the historic landscape.
- x. To provide sufficient information to enable the LTC archaeological advisor, in consultation with the Key Archaeological Stakeholders, to determine the significance of the archaeological assets identified within the land parcel.



- xi. To provide a report on the discoveries to inform the Environmental Statement (ES) supporting the Development Consent Order (DCO) and support the preparation of a further archaeological mitigation strategy for the Enabling Works and Construction phases of the scheme.
- xii. Following the DCO, to deposit the report in the public domain, and to generate an accessible and useable archive which will allow future research of the evidence to be undertaken.

## 2.2 Specific objectives

### 2.2.1 The specific project objectives were as follows:

- xiii. To conduct the programme of archaeological investigation within the general research parameters and objectives defined by the revised East of England Research Framework (ed Medlycott 2011), and to take account of the aims and objectives of the Greater Thames Estuary Historic Environment Research Framework.
- xiv. To clarify through targeting of apparently blank areas whether the cropmarks provide an accurate representation of the range, quantity and types of archaeological features present within the site.
- xv. To clarify whether sites or finds of late Upper Palaeolithic or Mesolithic date exist within hollows or on the surface below subsoil in the terrace areas of the site, and if so, to define the date of these (particularly within the Mesolithic period), the extent of any concentrated activity areas, and their character.
- xvi. Within dry valley bottoms and sides, to establish the depth and complexity of the colluvial sequence overlying the Pleistocene geology, and if possible to date and interpret this.
- xvii. To look for buried archaeological horizons and finds scatters within the colluvial sequence. This is likely to be particularly relevant for sites of the late Upper Palaeolithic, Mesolithic and Neolithic periods, but sites of later periods may also survive buried beneath colluvium, or eroded from upslope.
- xviii. To clarify the potential for particularly well preserved deposits, whether structural, artefactual or ecofactual, in these protected locations.
- xix. To investigate the distribution, density and character of Neolithic and Bronze Age activity within the site, and to examine whether there are any foci of activity, whether around burial monuments or cemeteries of the same periods or around monuments of other kinds.
- xx. To clarify whether burial monuments of the Neolithic and early Bronze Age were foci for reuse, whether peripheral burial, deposits related to visits, or for burial or other purposes in later periods.
- xxi. To establish the extent, character and density of later prehistoric and Roman activity within the site, and in particular, whether the two rectilinear cropmark enclosures within the site are prehistoric or Roman, and establish their character, functions and duration of use.
- xxii. To determine whether further evidence of pottery production is present within the scheme area, and if so, to date and characterise this.

- xxiii. To look for evidence of the projected Roman roads and trackways within the site, as trackways appear to extend from the two possible rectilinear cropmark enclosures.
- xxiv. To establish the date of the possible north-south aligned droveways that have been identified within the site.
- xxv. To look for evidence of medieval farmsteads or cottages along major roadways.
- xxvi. To look for evidence of the post-medieval farmstead or cottages which may have been located just north of the Muckingford Road, and the post-medieval buildings that may also have existed within the site.

## 3 Methodology

---

### 3.1 Constraints

- 3.1.1 Several constraints limited the area of the site available for trial trenching. These included previously quarried areas, overhead power lines, buried irrigation pipes a sewer pipe and ecological constraints.
- 3.1.2 These limitations were considered when designing the detailed trench layout and are discussed in detail in the WSI. However, as the trench layout was agreed prior to the commencement of fieldwork, some alterations were required at the time of excavation to take account of changes in the natural environment and consequent amendments to the ecological constraints. The areas concerned were particularly around the margins of the fields and the large pond present in parcels 7a and 7b.

### 3.2 Methodology for the evaluation

- 3.2.1 The total land area of parcels 6, 7 and 8 was 59.64ha, and the area available for investigation excluding areas of services, hedgerows and other constraints was 33.05ha. A total of 224 trenches were excavated. Of these, 2 trenches measured 20m x 2m, 158 trenches measured 30m x 2m and another 64 trenches were stepped out to a width of 6m either partially or entirely along their length to allow deeper excavation below 1m. Combined, these represent a minimum 4% sample of the area available for trenching. The location of the trenches is shown on Figure 2.
- 3.2.2 The trench design was developed to target cropmark features identified by the aerial investigation and mapping report (Place Services 2019), and otherwise to provide even coverage of the blank areas. Several of the trenches were also positioned in line with each other to create transects across the valley sides and bottoms.
- 3.2.3 Trenches 52, 53, 54, 55 and 56 were descoped from the investigations prior to the commencement of fieldwork due to their location. Trenches 37, 38, 108, 114, 119, 124, 128, 130, 131, 134, 135 and 136 were not excavated due to their proximity to a watercourse and ecological concerns about the amount of habitat that would need to be removed to allow access. Trenches 73 and 83 could not be excavated as these coincided with an area of contaminated ground resulting from fly-tipping.
- 3.2.4 Whilst consideration was given to the relocation of trenches that could not be excavated, the large footprint of the deep trenches and the reduction in the available area because of the constraints meant that only a small number could be moved.
- 3.2.5 The following 16 trenches were all moved from their original positions to avoid constraints: 27, 36, 35, 82, 101, 100, 109, 110, 111, 112, 116, 151, 229, 234, 243 and 230
- 3.2.6 A small number of other trenches were also relocated once the fieldwork had begun. This followed an assessment of the site topography and was intended to provide better locations to facilitate understanding of the formation of

colluvial and alluvial deposits. The 10 trenches relocated for this reason comprised: 29, 32, 31, 50, 47, 46, 138, 139, 91 and 103.

- 3.2.7 Trench 104 was also moved from its original position once fieldwork had begun to help establish the extent of a flint scatter that had been identified in Trench 103 adjacent.
- 3.2.8 All trenches were located using a Global Positioning System (GPS) prior to machine excavation. All trenches were excavated using a tracked excavator fitted with a toothless bucket under constant archaeological supervision.
- 3.2.9 Revealed features were hand cleaned and sampled by hand excavation. They were recorded as outlined within the approved WSI. All finds were bagged by context throughout the evaluation and were recovered for further investigation, and soil samples were taken as appropriate.

## 4 Results

---

### 4.1 Introduction and presentation of results

- 4.1.1 The results of the evaluation are presented below and include a stratigraphic description of the trenches that contained archaeological remains. The full details of all trenches with dimensions and depths of all deposits can be found in Appendix A. Finds data are tabulated in Appendix B.
- 4.1.2 Context numbers reflect the trench numbers, unless otherwise stated. For example, ditch 803 is a cut within Trench 8, while pit 1719 is a cut within Trench 17.
- 4.1.3 An overview of the results for the site is shown on Figures 3-5. Further detailed plans of the trenches which contained archaeological features and selected sections are shown on Figures 6-45. The locations of the geoarchaeological transects are also shown in Figures 3-5, and the transects themselves in Figures 46-59.
- 4.1.4 Due to the number of trenches and the unusual shape of the site, the archaeological remains will be presented below by the land parcel. The land parcel numbering provides a useful sub-division of the site and is illustrated in Figure 2.

### 4.2 General soils and ground conditions

- 4.2.1 The soil sequence was varied across the site due to changes in topography, groundwater and the underlying geology. Generally the more elevated areas of the site in the north of parcel 6 and along the northern edge of parcel 7 revealed a shallow ploughsoil coming directly onto the underlying geology. Moving down from the highest sections of the site an accumulation of colluvium was found between the ploughsoil and the underlying geology, which was inevitably thickest in the base of the dry valleys across parcels 6 and 7. In places, this colluvium overlay areas of buried soil. In the valley base of land parcel 7a, the high groundwater level had contributed to the development of a humic peaty soil beneath the colluvium. Beneath this was further colluvium that overlay Pleistocene deposits. Although relatively flat compared to other areas of the site, a shallow colluvium was also recorded in some of the trenches in the central and southern section of parcel 7c. Up to 0.3m thick, this overlay the natural geology and was truncated by the archaeological features.
- 4.2.2 The archaeological horizon was encountered between 0.3m and 1m below existing ground level, varying due to the topography. A more detailed discussion of the soil sequence across the site is included below in Appendix C.7.
- 4.2.3 Ground conditions throughout the evaluation were varied. Due to the duration of the fieldwork the weather conditions ranged from dry hot weather to cooler periods with some prolonged and heavy rain showers. In the southern part of parcel 7c a particularly heavy downpour of rain washed a considerable amount of the recently ploughed ploughsoil into the trenches as they became flooded. Although this drained away relatively quickly, the remaining sediment

obscured any remains in these trenches and had to be removed from the trenches by machine.

- 4.2.4 Groundwater was also a persistent problem in the low-lying trenches located along the valley base, particularly in parcels 7a and 7b, the northern end of 7c and the northern end of parcel 8. Combined with soft, fine-grained sediments the permanent waterlogging in these trenches meant that the trench edges became eroded and, in some cases, collapsed. Inevitably, there was a limited amount of investigation that could be safely undertaken in these circumstances. Ingress of water during the excavation of the trenches also made it difficult to identify features that may have been present.

### 4.3 General distribution of archaeological deposits

- 4.3.1 Archaeological features (including flint scatters) were found in the following trenches:

- **Land Parcel 6** - 3, 5, 7, 8, 9, 10, 11, 17, 27, 28, 32, 40, 41, 42, 49 and 48.
- **Land Parcel 7a** - 61, 68, 69, 67, 75, 76, 85, 79, 82, 89, 90, 91, 92, 93, 94, 95, 96, 97, 98, 99, 100, 101, 102, 103, 104, 105, 107 and 109.
- **Land Parcel 7b** - 120, 126 and 127.
- **Land Parcel 7c** - 138, 139, 141, 140, 149, 150, 151, 152, 159, 161, 162, 163, 164, 165, 166, 167, 168, 170, 174, 175, 176, 178, 179, 180, 181, 182, 183, 184, 185, 186, 187, 190, 191, 194, 196, 197, 198, 202, 207, 208, 213, 216, 223 and 226.
- **Land Parcel 8** - 229, 230, 234, 235, 237, 238, 239, 240, 241, 242 and 243.

- 4.3.2 The cropmarks identified in the aerial investigation and mapping report within these land parcels (Place Services 2019) were limited to possible ditched enclosures and associated ditches or trackways on the high promontories of land parcels 6 and 7a. Cropmark evidence from the surrounding fields however indicated a high density of archaeological activity in the immediate vicinity, particularly on the west and east.

- 4.3.3 In Land Parcel 6 a small cluster of truncated features were revealed in correlation with the mapped cropmark features on the high ground in the north-west of the parcel. These sat in relative isolation with better-preserved and denser activity recorded towards the valley base in the southern section of the site around Trenches 40 and 48.

- 4.3.4 A relatively dense cluster of large pits and enclosure ditches was recorded in relation to the cropmark features on the south facing slope of parcel 7a. The north facing slope revealed few archaeological features but an apparently *in situ* flint scatter was recorded concentrated around Trench 104 and extending into Trenches 103, 105 and 99. Concentrations of worked flint were also recovered from Trenches 97, 98 and 107, demonstrating that this activity was present along both sides of the valley base.

- 4.3.5 Archaeological features in parcel 7b were limited to a ditch in Trench 120 and discrete features in Trenches 126 and 127.

- 4.3.6 In land parcel 7c there was a small concentration of shallow features in the north-west corner around Trench 138. These were complemented by a reasonably large number of worked flints, although no *in situ* scatters were identified. The main concentration of activity was across the central and eastern section of this land parcel, where numerous ditches and discrete features were recorded, including a crouched inhumation in Trench 176.
- 4.3.7 The activity extended east across the modern field boundary into Land Parcel 8, where further ditches and pit clusters of a similar character and date to those in parcel 7c were revealed.

#### 4.4 Trenches 3-5 and 7-11 (Figs 3, 6 and 7)

- 4.4.1 Land Parcel 6 was wrapped around the north-east edge of Land Parcel 5, and had two northern projections, one on the north-west and the other on the north-east, both of which corresponded to dry valleys running in from the north.
- 4.4.2 Trenches 1-11 were located at the north-west end of Land Parcel 6 (Fig. 3). Trenches 1 and 2 were blank. Trenches 3-6 were located in the base of a small dry valley aligned roughly N-S and sloping down to the south. Trenches 7, 8, 9, 10 and 11 were positioned slightly to the east on an elevated promontory that also sloped gently to the south. Trenches 8, 9, 10 and 11 were also positioned to investigate a group of cropmarks thought possibly to indicate a driveway and an enclosure.
- 4.4.3 **Trench 3** was positioned at the lower end of the N-S aligned dry valley at its junction with a larger dry valley running from Land Parcel 5 to the west across Land Parcel 6 and continuing ESE across Land Parcel 7a. The permitted depth of excavation for this trench was limited to 1m below ground level, which was sufficient to reveal the natural geology (314) across the middle of the trench, but left colluvium in the base at the northern and southern ends (Fig. 6, deposits 311 and 326). A struck flint was recovered from the surface of natural 314. Although the colluvial deposits at either end were not excavated in detail due to their depth, several sherds of early post-medieval pottery (AD 1480-1600) were recovered from deposit 326 along with a medieval Lace Chape and an iron key. An environmental sample (Sample 102) from layer 326 produced charred remains of charcoal and wheat.
- 4.4.4 Near the centre of the trench was an irregular feature 313, broadly aligned N-S, which was at least 6m in length and measured in excess of 1.1m wide, extending beyond the western trench edge. It was up to 0.53m deep with steep irregular sides and an uneven base (Fig. 7, Section 304), and was filled with a grey silty clay (314/320) that contained several fragments of fired clay, occasional charcoal flecks and also a piece of worked flint. Given the topographical position and the orientation of the feature, it is probable that this was a gully formed by natural erosion of the underlying geology which then silted up, incorporating material from an adjacent area of domestic or industrial activity.
- 4.4.5 Deposit 313 was truncated by pit 316, which was sub-circular in plan, at least 0.6m in diameter and 0.4m deep with steep sides and an irregular base (Fig. 7, Section 304). It was filled with a sequence of naturally silted, grey and greyish brown deposits (317, 318 and 319) which contained some charcoal

flecks, but no finds. A similar pit, 321, lay less than 1m to the south. This was sub-circular in plan, 1.4m in diameter and was at least 0.43m deep, but was not bottomed (Fig. 7, Section 305). This pit contained two mixed deposits of silty clay, 323 and 322, which suggested deliberate backfill, and these incorporated fragments of CBM and two small sherds of Roman pottery.

- 4.4.6 North of feature 313 were three small sub-circular pits or postholes 304, 306 and 308 forming a roughly N-S line. Pits 304 and 306 were 1m apart, 306 and 308 around 2m apart. They all had steep sides but were shallow, varying from 0.08m to 0.22m deep, with slightly concave profiles and a single fill of greyish brown silty clay. Pit 308 was slightly deeper than the other two and was also disturbed by bioturbation. None of the pits produced any artefacts. A fourth similar pit, 310 lay 2m south of 308 and slightly west of the N-S line on the edge of feature 313, but was left unexcavated. All the features in this trench were overlain by up to 0.3m of colluvial subsoil.
- 4.4.7 **Trench 4** was north of Trench 3 within the dry valley, and was excavated to a depth of 2m. No archaeological features were found within this trench, but there was a deep sequence of colluvial and alluvial fills, of which colluvium 402 contained infrequent charcoal flecks and a little late Bronze Age or early Iron Age pottery, and alluvium 410 later prehistoric pottery.
- 4.4.8 **Trench 5** was located to the north of Trench 4, slightly further up the N-S aligned dry valley. Excavated to a depth of 2m it revealed a sequence of colluvial layers 1.67m deep, overlying buried soil horizons, 504 and 510. Colluvial layer 503 formed over the surface of deposit 504. It measured 0.5m thick and contained burnt flint and common charcoal and produced several small sherds of middle Bronze Age to middle Iron Age pottery. In the northern half of the trench, two possible stakeholes (506 and 508) penetrated the surface of deposit 503. They measured 0.08m and 0.05m in diameter and 0.09 and 0.15m deep respectively with near vertical straight sides. Both features contained a dark grey silty sand deposit with charcoal flecks. Two small scraps of later prehistoric pottery were recovered from deposit 507, the fill of stakehole 506.
- 4.4.9 The stakeholes were sealed beneath colluvial layers 502 and 501. Fragments of burnt flint and charcoal were recorded in deposit 502 and a fragment of Roman tegula and a scrap of Roman pottery from colluvium 501.
- 4.4.10 **Trench 7** was located north-east of Trench 5 at (c 23m aOD), the highest elevation trenched within Land Parcel 6. It revealed a single N-S aligned ditch (705) that measured 0.5m wide and 0.08m deep with a shallow concave profile (Fig. 7, Section 702), and was filled with 706, a single sterile deposit of silty sand.
- 4.4.11 **Trench 8** lay south of Trench 7 and east of Trench 5, and revealed a small pit. Pit 803 was sub-circular in plan and 1.12m wide and 0.32m deep with an uneven concave profile (Fig. 7, Section 800). It was filled with a deposit of greyish brown silty sand (804), which produced two sherds of Anglo-Saxon pottery. This deposit was sampled for environmental remains (Sample 12) but only produced a small flint with charred goosefoot seeds.
- 4.4.12 **Trench 9** was positioned to the south of Trench 8 and across the line of two parallel linear cropmarks aligned NNE-SSW. No trace of archaeological



features corresponding to the linear cropmarks was found, but the trench did contain a small pit. Pit 903 was circular in plan, 0.73m in diameter and 0.27m deep with steep sides and an uneven concave profile (Fig. 7, Section 900). It contained a single sterile fill of brownish grey silty sand. Sampling of this feature produced a poor flint in which the only identifiable fragment was a charred speedwell seed (Sample 13).

- 4.4.13 **Trench 10** was approximately 20m to the south of Trench 9, and also lay across the line of one of the parallel linear cropmarks and across a second cropmark possibly belonging to a rectilinear enclosure. At the western end the trench exposed a ditch on a WNW-ESE alignment. Ditch 1005 measured 0.7m wide and 0.28m deep and had a narrow concave base, and a single fill of sterile silty sand (1006). Towards the centre of the trench was a possible pit or ditch terminus (1003), which was 0.7m wide and 0.42m deep with steep sides and a flat base (Fig. 7, Section 1000), and contained a similarly sterile fill (1004).
- 4.4.14 The absence of ditches clearly corresponding to any of this group of cropmarks casts doubt upon whether these cropmarks do represent archaeological features. The position of 1003 correlates with one of the NNE-SSW linear cropmarks targeted by this trench, but insufficient of this feature was exposed to determine whether 1003 was part of this, or was unrelated. The alignment of ditch 1005 was the same as that of the north side of the possible cropmark enclosure plotted nearly 20m further north (Fig. 6), but no trace of the eastern arm of this cropmark feature was seen in the trench, so whether this is coincidence or not is uncertain.
- 4.4.15 **Trench 11** was positioned further down the slope and to the south of Trench 10. It revealed a ditch aligned NW-SE at its western end. Ditch 1106 was up to 1.46m wide and only 0.14m deep with a shelving somewhat irregular base (Fig. 7, Section 1101). It contained a naturally silted deposit of light brown silty clay (1107), which produced several sherds of medieval pottery dating to the 11th or 12th century. This feature was aligned along the contour of the valley side and closely matches the position of a footpath marked on the 19th century mapping. It is therefore perhaps a boundary defining the footpath or a remnant of the footpath itself.

## 4.5 Trenches 17, 20, 27, 28 and 32 (Figs 3, 8 and 9)

- 4.5.1 These trenches lay east of Trenches 7-11, and occupied the north-eastern part of Land Parcel 6 (Fig. 3). Trenches 12-24 ran along the south side of Land Parcel 6, following the base of the WNW-ESE dry valley, meeting the dry valley coming in from the NNE in Trenches 25 and 26, while Trenches 27-36 extended along the lower western slope and base of the dry valley running in from the NNE.
- 4.5.2 Trench 17 was positioned some way east of Trench 11, and halfway along the southern edge of Land Parcel 6. Trenches 27, 28 and 32 all lay within the base of the dry valley coming in from the NNE.
- 4.5.3 **Trench 17** revealed a sub-circular pit cut into the surface of colluvial layer 1701 and sealed beneath the ploughsoil. Pit 1703 had a concave profile and measured 1.02m in diameter and 0.16m deep (Fig. 9, Section 1700). It contained a deposit of reddish, grey- brown sandy silt (1704) that produced

10 sherds of late Bronze Age to early Iron Age pottery and a piece of worked flint. An environmental sample was taken from this feature (Sample 11) but produced only a few charcoal fragments.

- 4.5.4 **Trench 20** lay some 55m east of Trench 17. No archaeological features were found in this trench, but it contained two colluvial fills (2002 and 2003), a reddish-brown silty sand and a greyish-brown sandy silt respectively, and a struck flint was recovered from the latter.
- 4.5.5 **Trench 25** lay south-east of Trench 20 and south of Trench 27 at the junction of the two dry valleys. There were no archaeological features in this trench, but it did contain a deep sequence of deposits. At the base of the exposure were Pleistocene slopewash deposits 2510 and 2509, followed by a pale clayey silt (2508) that was followed by a light grey or greyish-brown buried soil (2507). This was overlain by a peaty, dark greyish brown clayey silt (2506) with a further buried soil (2505), this time a very dark brown clayey silt, overlying it. This was sealed by a sequence of colluvial deposits (2504-2502) below subsoil and topsoil. Environmental sample 103 was taken from deposit 2505, and samples 104 and 105) from deposit 2506. Only occasional charcoal came from Sample 103, but decayed wood, reed seeds and occasional insect remains were also noted in Samples 104 and 105, showing that this deposit had been waterlogged.
- 4.5.6 **Trench 27** was located to the north-east of the junction between the two dry valleys. A NE-SW aligned ditch was revealed in the south-east corner of the trench. Ditch 2703 measured 0.47m wide and 0.19m deep with steep sides and an irregular base (Fig. 9, Section 2700). It had a single sterile fill of light grey-orange clay sand. This ditch was cut into the natural geology 2702 and overlain by colluvial layer 2708, from which a struck flint was recovered. A thin grey colluvial sediment (2707) was also present at this horizon on the western, lower side of the trench. This was incorporated flecks of charcoal in varying concentrations, the densest of which were investigated as possible features but were concluded to be variations within the colluvial accumulation due to human activity upslope to the north-east or north-west.
- 4.5.7 **Trench 28** was positioned immediately to the north-west of Trench 27. In the deeper southern end of the trench a remnant buried soil (2803) that contained charcoal was recorded overlying the natural geology. This was overlain by colluvial layers, 2802, 2808 and 2805. Towards the northern end of the trench the natural topography rose upslope and here a possible ditch terminus or pit 2806 was recorded. The full extent of the feature was not exposed, but it was slightly irregular in shape with an irregular concave base, and was up to 1.15m wide and up to 0.65m deep towards the terminal end (Fig. 9, Section 2800). It contained a single light blueish-grey, clayey sand fill (2807) with charcoal, from which worked flint was recovered. On the opposite side of the trench was a very diffuse and irregular feature (2809), predominantly visible in the trench section (Fig. 9, Section 2801). Although it contained two fills with frequent flecks of charcoal throughout, the irregular appearance of this feature suggests that it was probably a tree-throw hole.
- 4.5.8 **Trench 29** lay north-east of Trench 28. No archaeological features were found in this trench, but a struck flint was recovered from the topsoil.

- 4.5.9 **Trench 32** was located approximately 50m to the north-east of Trench 27. Below the ploughsoil was a layer of colluvium 3201, from which a struck flint was recovered. At the north-west end of the trench was a curving arc of ditch. This ditch was not initially very clear and was removed along the deeper central part of the trench during machining, but was subsequently identified and recorded on the south-west side below the ploughsoil and cutting through colluvial layer 3201. The ditch was not evident on the north-east side of the trench, so did not form a circle. Ditch 3206 measured 0.75m wide and at least 0.31m deep and had steep sides and a flattish base (Fig. 9, Section 3202). Within the ditch were two naturally silted, sterile deposits 3207 and 3208. Although undated, its stratigraphic position suggests that it is likely to be medieval or later.
- 4.5.10 Ditch 3204 was recorded on the north-east side of the trench towards the south-east end running on a NW-SE alignment. It measured 0.56m wide and only 0.08m deep with a concave profile (Fig. 9, Section 3201) and had a single fill of light grey silty clay (3205). A sherd of Roman pottery was recovered from this deposit. This ditch was sealed beneath colluvial layer 3201 and was cut through probable slope deposit 3200.
- 4.5.11 **Trench 31** lay east of Trench 32, and like it, contained a sequence of colluvial and other layers. Among these were two buried soils (3103 and 3106), of which the first contained later prehistoric pottery and the second struck flint. Struck flint also came from colluvial deposit 3108.

## 4.6 Trenches 40- and 48-9 (Figs 3, 10 and 11)

- 4.6.1 This group of trenches lay south of Trenches 25 and 26 in the south-eastern end of Land Parcel 6, on the gently sloping, west-facing side of the dry valley (Fig. 3).
- 4.6.2 **Trench 40** revealed a large spread of burnt flints and charcoal in a deposit of dark grey sandy silt with occasional charcoal flecks (4005) (Fig. 11, Section 4000; Plate 1), sitting upon layer 4002, a yellowish brown sandy silt. It was interpreted as being within a shallow and uneven cut feature (4004), but it was more probably a spread of material that accumulated within a naturally occurring depression, as it extends beyond anything identifiable as a deliberate cut. Layer 4002 was interpreted as a buried land surface. Overall, the charcoal-rich deposit covered an area approximately 4.4m wide (north to south) and extending beyond the east and west edges of the trench, measuring up to 0.1m thick. No *in situ* burning was associated with this material, but based on the quantity and density of the charcoal and flint it probably represents rake-out material from an adjacent feature. No artefacts were found in this layer and an environmental sample (Sample 76) produced only charcoal and an indeterminate fragment of grain.
- 4.6.3 Deposit 4005 was sealed beneath 4003, a thin layer of light grey sandy silt with frequent charcoal flecks that extended across the southern two-thirds of the trench. The slightly gleyed appearance of this deposit suggests that it may have been either a leached colluvial deposit or alluvial in origin.
- 4.6.4 **Trench 41** was to the east of Trench 40, slightly further up the side of the valley. It contained a very shallow N-S aligned ditch. Ditch 4103 was 0.7m wide and 0.14m deep, with a single dark fill that was without finds. No

continuation on the projected line of this ditch was seen in Trench 45 to the south. Although the feature was undated, it matches the alignment of a short field boundary marked on 19th century mapping (Fig. 10), and although offset from this, probably represents this boundary.

- 4.6.5 **Trench 42.** Ditch 4200 was recorded at the western end of the trench on an ENE-WSW alignment. It measured 0.9m wide with a concave base, was 0.28m deep and was filled with a naturally silted, sterile deposit (4201).
- 4.6.6 A separate pit (4205) was partially exposed, extending beneath the south facing section of the trench (Fig. 11, Section 4201). It had steep sides and an uneven base and was at least 1.28m wide and 0.3m deep. The lower fill (4206) consisted of charcoal-rich clayey sand with patches of reddish brown burnt material (Plate 2). Only charcoal was produced from the sample recovered from this deposit (Sample 21). This was overlain by a mixed deposit (4207) of orange-brown, clayey sand with large patches of burnt sediment but no charcoal. No finds were recovered from these deposits, but they possibly represent dumping from a dismantled hearth, oven or similar structure. Although undated, it is possible that this was associated either with the briquetage found in Trench 49 to the south, or with the burnt flint spread in Trench 40 to the north.
- 4.6.7 **Trench 49** was located to the south of Trench 42, near the base of the dry valley slope. Pit 4903 was recorded towards the southern end of the trench, concealed beneath a pocket of colluvium numbered 4902 (Fig. 11, Section 4900; Plate 3). The pit measured 1.3m in diameter with near vertical sides and was at least 0.4m deep, although the base of the feature was not reached. Its lowest fill (4904/4907) comprised dark brown grey, silty sand and was overlain by a similar, slightly lighter deposit, 4905. The pit produced an impressive assemblage of finds comprising 653g of late Bronze Age pottery and 69 fragments of briquetage. A small flint of charcoal was produced by the sample (Sample 73) recovered from deposit 4904 and included a probable wheat grain.
- 4.6.8 The overlying colluvium, 4902 covered an area approximately 8m in length at the southern end of the trench and also contained a piece of briquetage. Deposit 4902 was a light yellowish grey sandy silt, similar to 4003 and also contained fragments of charcoal, flint and pottery.
- 4.6.9 **Trench 48** was situated at the southern end of the land parcel, adjacent to Hoford Road. Ditch 4803 was only partially exposed at the south-western end of the trench on a broadly E-W alignment. It was 1.7m wide with a broad concave profile 0.4m deep (Fig. 11, Section 4800), and was filled with a naturally silted deposit of silty sand, 4804, which contained sherds of late Saxon pottery and medieval or post-medieval roof tile. No continuation of this ditch was seen in Trench 51 to the west.
- 4.6.10 To the north-east of 4803 was an ovoid feature, 4805. It measured 0.66m wide and only 0.08m deep with an uneven base and a fill of greyish brown silty sand. This may have been a remnant patch of subsoil rather than an archaeological feature.
- 4.6.11 Ditch 4807 was 0.9m wide and 0.14m deep with an uneven concave profile (Fig. 11, Section 4803). It contained a single sterile fill of light greyish brown

silty sand. A third ditch, 4809 was recorded further to the north-east end of the trench. It was 1.49m wide and 0.3m deep with moderately steep sloping sides. It contained an initial deposit of dark, charcoal-rich, orange-brown silty sand (4810). This fill produced five fragments of post-medieval roof tile, animal bone and a residual sherd of possible late Bronze Age pottery. The ditch fill was overlain by a deposit of sterile orange-brown silty sand (4811).

## 4.7 Trenches 60-1, 67-9, 75-7 and 85 (Figs 4, 12 and 13)

- 4.7.1 This group of trenches were positioned on an elevated plateau, high on the south facing slope of the valley in Land Parcel 7a (Fig. 4). They were targeted on a series of cropmark features suggesting a rectilinear ditched enclosure, double-ditched on the south and east sides, and intersected by two ditches at right angles on NW-SE and SW-NE alignments. The trenches located ditches corresponding to most of the linear cropmarks, although the ditches were mostly offset from the cropmarks, being up to 2.5m further east, and mostly 1m further north, though there was more variation in the N-S direction.
- 4.7.2 **Trench 60** was positioned at the north-west edge of this group close to the Hoford Road, and targeted a large discrete cropmark (Fig. 4). No archaeological feature corresponding to the cropmark were found, nor any other features in this trench.
- 4.7.3 **Trench 61** lay east of Trench 60 and was targeted upon a NW-SE aligned cropmark. It revealed corresponding ditch 6107 which measured 1.52m wide and 0.4m deep with a wide concave profile (Fig. 13, Section 6102), and contained a single, sterile fill of naturally accumulated silty sand (6108).
- 4.7.4 Ditch 6109 was also revealed at the south-west end of the trench, running on a parallel alignment. It measured just 0.5m wide and 0.14m deep with a rounded base, and also contained a naturally silted sterile deposit of silty sand numbered 6110. A third ditch (6105), running ESE approximately 10m to the north-east of ditch 6107m was of very similar size, and also contained one similar sterile fill.
- 4.7.5 Feature 6103 was a small charcoal-filled pit north of ditch 6105. It is unclear if this was the result of deliberately dumped material or if in fact it represents the remains of a tree bole burnt *in situ*.
- 4.7.6 Trench 67 was located south-west of trench 61 and south of Trench 60 (Fig. 4) and revealed a single small pit towards the north end. Pit 6703 measured 0.34m in diameter with a rounded base, 0.07m deep. It was filled with a deposit of charcoal rich sandy clay and burnt stones. The environmental sample (Sample 87) recovered from deposit 6704 contained a small amount of charcoal and a small sherd of prehistoric pottery, possibly early Neolithic but more likely of later prehistoric date.
- 4.7.7 **Trench 68** was located to the south-east of Trench 61, targeting the north-east side of the rectilinear cropmark. It was also placed over a NW-SE aligned cropmark that relates to ditch 6107 and revealed a continuation of this feature. Ditch 6802 had a similar concave profile to 6107 and contained a primary deposit of silty sand (6803) overlain by a dark grey silty sand (6804) with frequent charcoal flecks.

- 4.7.8 At the north-east end of the trench, ditch 6805 was recorded in a NW-SE alignment, matching that of the enclosure cropmark. It measured 2.26m wide and 0.77m deep, with moderately sloped, straight sides and a narrow base (Fig. 13, Section 6802; Plate 4). It contained just a single identifiable fill (6806), comprising reddish brown sandy silt which produced two small sherds of Roman pottery and several pieces of worked flint.
- 4.7.9 Ditch 6811 was located approximately 4m to the north-east of 6805, on a parallel alignment. It measured 1.5m wide and was at least 0.6m deep, but the base was not revealed as it exceeded the permitted depth of excavation (Fig. 13, Section 6803). The upper fill of the ditch was a sterile, greyish brown sandy silt deposit, 6812. On the south-west side of the ditch it truncated a shallow ditch terminus or pit, 6809, which measured 1.3m wide and 0.43m deep with a rounded end terminating in the centre of the trench. It was filled with a sterile sandy silt deposit similar to 6812. This truncated a sterile deposit (6808) that had accumulated to the south-west. This deposit was confined to the area just north of ditch 6805, and it is possible that it was associated, perhaps representing upcast from the ditch later truncated by the ditches to the north.
- 4.7.10 **Trench 75** was positioned on the western side of the cropmark enclosure, and revealed a corresponding ditch on a parallel alignment offset 2m to the east. Ditch 7502 measured 0.68m wide and just 0.13m deep, and contained a single, brownish grey silty sand fill (7503) that did not produce any finds. The narrowness and shallowness of this ditch in comparison to the dimensions of the cropmark here suggests that the ditch had been significantly truncated by later ploughing.
- 4.7.11 **Trench 69** was positioned to investigate an apparent gap in the north-east corner of the cropmark enclosure. Excavated to a depth of 1m, a remnant of colluvium (6903) remained in the southern end of the trench covering an area of approximately 7.5m. This appeared to be partially sealing a NE-SW aligned linear feature, 6906. Due to its depth below ground level it was left unexcavated, but may have been a continuation of one of the ditches at the north-west end of Trench 77. No finds were recovered either from the surface of the fill or from the overlying colluvium.
- 4.7.12 Ditch 6904 was recorded immediately to the south of 6906 on a NW-SE alignment. It measured 0.39m wide and 0.09m deep with a concave profile and a fill of dark brown sandy silt, 6905. It was interpreted as cutting through colluvium 6903, but this relationship is uncertain, as it is possible that the thin colluvium allowed the dark deposit of 6905 to be visible through it. Three small scraps of late prehistoric pottery, a fragment of fired clay and some flint were attributed to fill 6905. Ditch 6904 was in line with larger ditch 6805 to the north-west.
- 4.7.13 Both ditch 6904 and colluvium 6903 were overlain by two further colluvial layers, 6902 and 6901 with a combined depth of almost 0.9m.
- 4.7.14 **Trench 77** was placed to the south of Trench 69 and targeted the eastern side of the cropmark enclosure along with part of the interior. Two parallel ditches were revealed at the eastern end of the trench, matching the position and orientation of the parallel cropmarks of the double-ditched enclosure. The eastern ditch (7714) measured 1m wide and 0.31m deep with shelving sides

and a pointed base (Fig. 13, Section 7704) and was filled with a sterile deposit of silty sand (7715). Approximately 3.5m to the west, ditch 7703 measured 1.6m wide and 0.5m deep, with sloping sides and a rounded base (Fig. 13, Section 7702). It contained two naturally silted fills of silty sand and gravel, 7704 and 7705, the later of which (7705) was initially interpreted as the fill of a recut given the number 7716, although it is probably simply an upper fill. No artefacts or dating evidence was recovered from either deposit.

- 4.7.15 At the north-west end of the trench four separate ditches were recorded, three (7708, 7710 and 7712) on broadly NE-SW alignments and narrower gully 7706 on an E-W alignment. The easternmost ditches (7710 and 7712) are illustrated (Fig. 13, Section 7703). The largest of these (7708) measured 1.04m wide and 0.23m deep, but they were all broadly similar in appearance, with shallow pointed profiles and sterile fills of brown gravelly sand. A short NE-SW aligned cropmark was mapped at the west end of the trench, and although offset several metres to the west, does correlate with the alignment of ditch 7708, but the plotted cropmark is only a fraction longer than the width of the trench, so does not explain its purpose.
- 4.7.16 **Trench 76** were located to the south-west of Trench 77 targeting the southern side of the enclosure and the area immediately to the south. Ditch 7607 was aligned NE-SE and coincides with the inner of the two cropmarks of the double-ditched enclosure, representing a continuation of ditch 7703. The ditch appeared to be somewhat truncated at this location, measuring just 0.7m wide and 0.22m deep, with a single sterile fill of brownish grey silty sand.
- 4.7.17 Ditch 7603 lay within the area defined by the cropmark enclosure, and was aligned NE-SW. It was 0.8m wide and 0.39m deep, and was filled with a dark brown, sandy gravel deposit (7604) that did not produce any finds (Fig. 13, Section 7600). This ditch ran parallel to a linear cropmark plotted 2m further west, and was probably the ditch indicated by this cropmark. The cropmark intersected with the inner of the double enclosure cropmarks, but was not plotted crossing the outer and more substantial cropmark or continuing south-west beyond the enclosure. The double ditches of the cropmark enclosure were confirmed on the eastern side of the enclosure, and although not tested by evaluation, were presumably also genuine on the south. The discovery of two parallel ditches in Trench 68 on the north suggest that there was a double boundary on this side as well, but no trace of a second ditch was found in Trench 75 on the west. The stratigraphy in Trench 68 on the north may indicate that the ditch circuits were consecutive rather than contemporary, but this would require further investigation to be certain.
- 4.7.18 **Trench 85** lay south of the cropmark enclosure, and contained a single ditch. Ditch 8503 was aligned NE-SW, was 0.71m wide and 0.15m deep with a single dark brown, sandy gravel deposit that did not produce finds. It ran on a very similar line to ditch 7603, and may have been a continuation of the same boundary.
- 4.7.19 **Trench 78.** Trench 78 lay south of Trench 77, and was also laid out to investigate the eastern side of the cropmark enclosure, but did not reveal any ditches corresponding to the double linear cropmarks. As the enclosure ditches that were found were narrower and shallower in the downslope

trenches, it seems likely that they had been completely eroded away in Trench 78.

- 4.7.20 **Trench 86** lay south of Trench 78 and was positioned south of the cropmark enclosure to cross a north-south linear cropmark that intersected with the outer enclosure cropmark boundary and ran south from it. No trace of a corresponding ditch was found within Trench 86, and this too may have been completely eroded away.

## 4.8 Trenches 90 and 101-2 (Figs 4, 14 and 15)

- 4.8.1 This group of trenches were situated in the base of the valley, at the western end of Land Parcel 7a (Fig. 4). Trenches 101 and 102 were on the southern side of the valley bottom, and Trench 90 a little further north on the northern side of the valley.

- 4.8.2 **Trench 101** revealed a complex sequence of large intercutting features. This was initially evident as the right-angled western corner of a large ditch running both north-east and south-east, further investigations demonstrated that it was also comprised of multiple intercutting pits.

- 4.8.3 A hand-excavated slot was dug across the south-western arm (Plate 5), and the earliest feature revealed was a circular pit or ditch terminus. Feature 10103 had very steep sides and a rounded base and was 0.49m wide and had been 0.89m deep, although its upper part had been truncated by later ditch 10105 (Fig. 15, Section 10100). It contained a deposit of blue grey clay (10104) that produced almost 300g of pottery dating to the 11th-12th centuries as well as bone, worked flint and shell and two iron objects, one of which was a knife blade fragment. Ditch 10105 was aligned north-west to south-east, and measured 1.63m wide and 0.57m deep, with a sloping SW side and a flattish base. Its fill of light brown-blue sandy silt (10106) produced several pieces of 13th century pottery, flint, bone, shell and some burnt stones. The north-east edge of the ditch was truncated away by a larger ditch on the same alignment (Fig. 15, Section 10100) Ditch 10107 was 2.34m wide and 1.08m deep with steep sides and a rounded base. It had a naturally silted lower fill (10108) of brownish grey, clay silt. This was overlain by thin layer of dark brown clay silt (10109) which was followed by a grey brown clay silt (10110). Layer 10108 produced several sherds of 19th century pottery and a broken clay pipe bowl dated to c 1820-1860, showing that this ditch was of post-medieval date. A small scrap of residual late Iron Age or Roman pottery was recovered from 10110, and worked flint and bone were also recovered from both 10108 and 10110. Ditches 10105 and 10107 both continued to the western corner and returned north-eastwards.

- 4.8.4 Cutting into the top of ditches 10105 and 10107 were two circular pits, 10111 and 10113. Both had shallow concave profiles and were of similar dimensions, approximately 1.4m in diameter and between 0.29m and 0.42m deep (Fig. 15, Section 10100). Pit 10111 was filled with a sterile naturally accumulated deposit of clayey sand (10112) and pit 10113 was apparently deliberately backfilled with a brown grey clay silt which produced post-medieval pottery, CBM fragments and some metalwork. Features 10116, 10117, 10118 and 10119 were pits truncated by ditch 10105, while 10115 and 10120 appeared to post-date the ditches, but none of these was excavated.



- 4.8.5 The 1st edition OS map, published in 1873 shows the corner of a field boundary that matches the location of ditches 10105 and 10107, although by the time the 2nd edition OS map was published in 1898 the NW-SE arm was no longer shown, and so had presumably become defunct. No continuation of these ditches was found in Trench 102 just to the north-east, but any continuation probably lay just beyond the end of this trench under its NW baulk.
- 4.8.6 Ditch 10105 contained only medieval pottery, although this may have been residual from earlier feature 10103, and ditch 10105 may have been considerably later, as is suggested by the fact that ditch 10107 closely follows its line. The line of pits cut by ditch 10107 presumably lay alongside earlier ditch 10105, and the later pits cutting ditch 10107 may represent the burial of rubbish along the former boundary when it went out of use.
- 4.8.7 **Trench 102** was located immediately to the north-east of Trench 101 but did not reveal any continuation of the large NE-SW aligned ditches. A small circular pit (10220) was partially revealed in the north-west corner of the trench (Fig. 15, Section 10205). It was filled with a deposit of dark brown silty clay (10221), with frequent charcoal and burnt clay fragments throughout. Two further similar pits containing burnt debris were also recorded in the trench. Pit 10218 was recorded in the south-west facing baulk (Fig. 15, Section 10204) and 10214 was located near the south-east end of the trench. Pit 10214 was ovoid in plan with steep sides and a slightly concave base, and measured 1.6m x 0.8m in plan and up to 0.41m deep (Fig. 15, Section 10203). It contained a mixed backfill, 10215, comprising silty clay with charcoal (Sample 15) and burnt clay throughout. This was overlain by a light brown silty clay deposit (10217) rich in charcoal (Sample 16). This was interpreted on site as the fill of a later recut (10216) but was more probably just a separate phase of infilling. Unusually, the charcoal in pit 10214 was almost entirely lime, but there was no artefactual dating.
- 4.8.8 At the south-west end of the trench were two broadly parallel, narrow linear features. Ditches 10208 and 10210 were respectively 0.58m and 0.48m wide and 0.28m and 0.22m deep, and both contained similar deposits of greyish brown silty clay. A single worked flint was recovered from deposit 10211, the fill of ditch 10210. A small posthole (10212) was recorded truncating the terminal end of ditch 10210, but on reflection this appears more likely to be an isolated patch of bioturbated sediment.
- 4.8.9 All the features recorded in this trench were cut into colluvial layers 10203 and 10204, interpreted as possibly of early Holocene date.
- 4.8.10 **Trench 90** was located to the north of Trench 102 and extended from the base of the valley, up the south facing slope. The south-west end of the trench was excavated to a depth of 2m below ground level revealing a deep sequence of colluvial deposits.
- 4.8.11 The earliest deposit at the base of the sequence was a probable Head deposit (9017), overlain by a fine slopewash deposit (9012) and a layer of redeposited Thanet sand (9010). Layer 9010 was then overlain by successive layers of colluvium or slopewash material represented by deposits 9009, 9008, 9007. In the lowest part of the trench at a depth of 1m below ground level, deposit 9007 is sealed beneath several layers of humic organic silt including 9006,

9005 and 9004, with a combined thickness of 0.37m. This formation of peat-like humic silt appears to be ubiquitous across the base of the valley, coinciding with the upper level of the water table. Overlying the peat was a probable slopewash layer (9003) which sealed layer 9004, followed by colluvium 9002 and 9001.

- 4.8.12 Whilst cleaning deposit 9005 a sherd of 19th century pottery and a fragment of post-medieval brick were recovered. However, the sediment fractions from the overlying deposit (9004) were radiocarbon dated and produced a combined date range of 1740-1620 cal BC (Beta-614821; 3370 ± 30 BP and Beta-614822; 3420 ± 30 BP). On balance, given the ground conditions and the soft nature of these deposits it is likely that the post-medieval finds were intrusive within the peat, especially as the peat in Trench 91 was also dated to the Bronze Age. The overlying slopewash layer 9003, contained several sherds of medieval pottery (c 1270-1350) which were probably derived from the activity around Trenches 93 and 94, to the east.
- 4.8.13 Towards the north-east end, at the more elevated end of the trench, the majority of the colluvial deposits had petered out. Cutting through the uppermost colluvium (9001) was a NW-SE aligned boundary ditch. Ditch 9013 measured approximately 2m wide and 0.38m deep with a broad concave profile (Fig. 15, Section 9002). It contained a deposit of brownish grey, silty clay (9014) that contained a flint flake. This ditch was recut along its south-west edge by ditch 9015. The fill of this feature (9016) was a sterile, reddish-brown silty clay.
- 4.8.14 Ditches 9013 and 9015 were broadly aligned with and close to a footpath recorded on 19th century mapping. Similar features were also recorded in Trenches 92, 96, 97, 98 and 107 to the south-east (Figs 4, 16 and 22) and are likely to be associated with the same historic footpath continuing along this contour of the valley.
- 4.8.15 **Trench 82** lay east of Trench 102 and south-east of Trench 90, and was positioned across the base of the valley on a NE-SW alignment (Fig. 14). Excavated to a depth of 2m it revealed a sequence of waterlogged colluvial layers. During excavation of the trench the presence of a possible pit and a ditch was highlighted by the machine watcher (Plate 6). Unfortunately, the rapid ingress of water led to the soft colluvial layers at the sides of the trench collapsing. It was therefore not possible to test these features further. The ditch was probably related either to a former watercourse or a footpath marked on 19th century historic maps.
- 4.8.16 A small sherd of post-medieval pottery was recovered from the hillwash (8201) directly below the ploughsoil and burnt flint was recorded in layer 8204, a pale olive sandy silt deposit approximately 1m below ground level.

## 4.9 Trenches 91-4 (Figs 4, 16 and 17)

- 4.9.1 This group of trenches were located on the lower, south facing slope of the valley east of Trench 82 (Fig. 4). Trenches 93 and 94 were positioned to target a rectilinear cropmark feature and Trenches 91 and 92 provided transects down the slope of the valley side (Plate 7).
- 4.9.2 **Trench 91** was the westernmost of the group and was orientated on a NNE-SSW alignment. The south end of the trench contained the deepest sequence

of colluvial fills, and was widened and deepened to 2m, revealing ten successive deposits. The northern part of the trench revealed a single sub-circular pit and a natural feature. Pit 9103 was approximately 0.8m in diameter and 0.27m deep, with moderately steep sides and a rounded base. There were two naturally accumulated fills (9104 and 9105), neither of which contained any finds. A linear soilmark (9106) ran ESE across the north end of the trench and was investigated, but proved to be irregular and was judged to be natural.

- 4.9.3 Pit 9103 was cut into layer 9113 (a possible head deposit) and was sealed beneath the subsoil and ploughsoil. At the base of the slope, layer 9113 was overlain by more than 2m of colluvium. These included redeposited Thanet Sand deposits, 9112 and 9110 which formed the earliest deposits at the base of the sequence. Overlying deposit 9110, was a possible buried soil layer 9109. It consisted of a brownish grey clay silt and measured 0.2m thick, with the upper horizon 1.05m below ground level. This was then overlain by successive peat deposits, 9108, 9120 and 9119 which together measured a combined thickness of 0.42m. The upper horizon of peat was defined by a thin layer of fine slopewash, 9107. This was in turn overlain by colluvium 9111 and the ploughsoil, 9100.
- 4.9.4 A series of radiocarbon dates, all paired dates using the soluble and insoluble fractions of the sediments, was obtained on the buried horizon and the overlying peat. The humic deposit 9109 gave dates of 3100-2935 cal BC (Beta- 614817; 4420 ± 30 BP) on the soluble fraction, and 3370-3110 cal BC (Beta-614818; 4540 ± 30 BP) on the insoluble fraction. These two dates fail an X<sup>2</sup>-T-test, but lie in the middle – late Neolithic period. The lowest deposit within the overlying peat, 9108, provided a combined date of 2140-1950 cal BC (Beta-614811; 3700 ± 30 BP and Beta-614812; 3630 ± 30 BP), dating from the early Bronze Age. The sample from 9119, the stratigraphic middle part of the peat, provided a date of 1870-1610 cal BC (Beta-614815; 3400 ± 30 BP) for the soluble fraction, and a date of 2140-1940 cal BC (Beta-614816; 3660 ± 30 BP) for the insoluble fraction. These dates do not pass an X<sup>2</sup> test, but again lie in the early Bronze Age. The upper, more silty peat deposit 9107 gave a combined date range of 970-820 cal BC (Beta-614819; 2750 ± 30 BP and Beta-614820; 2740 ± 30 BP) in the late Bronze Age. Although two of the four samples dated did not provide dates that passed the X<sup>2</sup> test, all four date ranges were in stratigraphic sequence, suggesting that a later Neolithic buried surface was overlain by peat that accumulated throughout the Bronze Age.
- 4.9.5 **Trench 92** lay east of Trench 91, and revealed a dense cluster of pits and ditches extending up to 10m south from the northern end of the trench. South of these, ditch 9212 was located near the centre of the trench on a NW-SE alignment. It was cut through the subsoil horizon and was filled with two deposits of naturally accumulated sandy silt (9213 followed by 9214). Some fragments of animal bone were recovered from fill 9213. This ditch was on much the same alignment and line as ditches 9013 recut as 9015 in Trench 90 to the north-west, and could represent a continuation of the same boundary.
- 4.9.6 Pit 9225 was the southernmost pit within the pit cluster, and was also the largest. Although only partially exposed in the trench it measured at least 2.2m

across and was in excess of 0.5m deep, though due to the depth of the adjacent baulk, the base of the pit was not reached (Fig. 17, Section 9206). Following an initial slumping of the sides represented by deposit 9244, the pit contained several episodes of deliberately dumped, charcoal rich silty clay (9226) which included several pieces of fired clay and a sherd of Roman pottery. This was overlain by a deposit of reddish brown silty clay (9228) with a final upper fill of greyish brown sandy silt (9227).

- 4.9.7 Pit 9207 lay immediately to the north of 9225 and also extended beyond the east edge of the trench. It had a slightly irregular plan and was 0.56m deep with a concave base (Fig. 17, Section 9201). The lower fill comprised reddish brown clay silt 9208, which was sterile. This was overlain by deposit 9209, which comprised a lower horizon of charcoal overlain by a dark brownish grey sandy silt. Several sherds of medieval pottery (c 1250-1350) were recovered from this deposit. The northern edge of the pit was truncated by shallow pit 2110 with sloping sides and a flat base, and with a single sterile fill (9211).
- 4.9.8 Pit 9221 was recorded on the western side of the trench, and was at least 1.39m wide and was 0.6m deep (Fig. 17, Section 9204). It had a single fill of naturally accumulated clay silt, 9222, from which a sherd of 12th century pottery was recovered. The upper part of the pit had been removed by ditch 9223, which was aligned NE-SW. The ditch was 0.69m wide and 0.26m deep with steep sides and a concave base, and was filled by sterile deposit 9224, a brownish grey sandy silt. On its south side ditch 9223 had an uncertain relationship with steep-sided pit 9232, but clearly truncated a cluster of intercutting pits at the northern end of the trench that included 9241, 9240, 9243, 9238, 9234, and 9242. Protruding from the western edge of the trench south of pit 9232, and opposite pit 9225, was pit 9230, which had sloping or shelving sides but was not bottomed (Fig. 17, Section 9204), and had no finds except for charcoal in its single exposed fill (9235). Along with other discrete pits south of the later ditch, comprising 9239 9233 and 9231, these form a concentrated pattern of activity with those north of the ditch, with surface finds of pottery dating the activity to between the 11th and 13th centuries. The precise function of these pits is, however, uncertain, as there was no consistent pattern of rubbish disposal or evidence for storage.
- 4.9.9 Ditch 9237 crossed the trench within the area of dense activity on a broadly E-W alignment, and although left unexcavated could be clearly seen truncating ditch 9223.
- 4.9.10 The archaeology in the northern part of the trench was dug into layer 9202 and sealed beneath colluvium 9204/9201. Two sherds of medieval (c 1270-1350) pottery were recovered from layer 9204. The southern end of the trench was excavated to a depth of 2m and revealed a deep sequence of colluvial deposits.
- 4.9.11 **Trench 93** was approximately 30m to the east of Trench 92 and was targeted upon two linear cropmarks that appeared to represent the north and south sides of a narrow cropmark enclosure open at the west end. No ditch was found corresponding to the southern linear cropmark, but the trench did reveal a ditch parallel to the northern cropmark some 2.5m north of its plotted position. Ditch 9306 was 1.57m wide and 0.67m deep with a V-profile, sloping sides leading to a narrow, rounded base (Fig. 17, Section 9301) A second

ditch was also seen in section parallel to 9306 and south of it, and was numbered 9304. This had steep sides and a concave base and was filled with sterile, naturally accumulated sandy silt (9305). Both ditches were cut into colluvial layer 9301. Based on the location of ditch 9304, it seems likely that it was a continuation of ditch 9237 in Trench 92 to the west.

- 4.9.12 The trench also revealed a cluster of pits sealed beneath colluvial layer 9301 further south. Towards the southern end of the trench, pit 9315 measured 0.75m in diameter and just 0.07m deep. It contained a sterile fill of sandy silt, 9316. Immediately to the north was a large irregular feature numbered 9317. This measured up to 4.6m across, and had an upper fill of greyish brown sandy silt which contained several sherds of 13th to 14th century pottery, but was not further investigated.
- 4.9.13 Further north pit 9314, similar in size to pit 9315, was partly exposed on the west side of the trench, and had a greyish brown sandy silt fill, but was not excavated. East and north-east of this was a group of smaller pits, four of which formed a roughly N-S line. Pit or posthole 9313 lay east of pit 9314, and was oval, measuring nearly 0.4m east-west and 0.25m north-south, but only 0.12m deep. It contained one sterile fill (9318). Pit 9309 was sub-circular in plan and was around 0.56m across and 0.35m deep with near-vertical sides and a flattish base (Fig. 17, Section 9302). It was filled by 9310, a deposit of brownish grey sandy silt that contained a sherd of medieval pottery. Small pit or posthole 9312 lay just south of 9309, and was about 0.23m in diameter, while oval pit 9308 lay 2.5m north of 9309, and measured 0.4m east-west and c 0.27m north-south. Both had similar greyish brown sandy silt fills to 9309, but neither feature was excavated. Pit 9311 was partly exposed just east of pit 909, and may have been of similar dimensions to it, but was again not excavated. Pit 9315 was also on the same alignment as the four smaller pits further north, and as it too contained medieval pottery could perhaps have been associated.
- 4.9.14 **Trench 94** lay east of Trench 93, and was targeted upon the east side of the narrow cropmark enclosure. At this end the cropmark also indicated an internal N-S division within the enclosure, with a narrow central gap suggesting an entrance (Fig. 16). Only one north-south ditch was found within the trench, and this lay 1m east of the plotted position of the internal cropmark division, but was continuous like the enclosure east end, whose plotted position was more than 3m further east. Ditch 9409 was 1.2m wide, but was not excavated. It cut a thin layer of colluvium surviving at the west end of the trench that was planned as 9403 (Fig. 16), and partly concealed pit 9404 just to the east of the ditch. This may, however, have been the lower interface of deposit 9401, a 0.4m thick colluvial layer present along the length of the trench.
- 4.9.15 Pit 9404 was a small sub-rectangular feature with vertical sides and a slightly concave base. It measured 1.5m x 0.72m in plan and 0.55m deep. In the base of the pit was a deliberate dump of material consisting of a dark grey, silty clay deposit with charcoal and fired clay fragments throughout (9407). This deposit was sampled and produced a flot containing wheat, barley, oat and several small legumes (Sample 18). It also had a large block of tufa placed in the base of the pit (Plate 9). Other finds from this deposit included several sherds of

13th century pottery, animal bone, a shaped lump of tufa and three residual sherds of Roman pottery. This was overlain by a sterile, orange brown silty clay, 9406.

- 4.9.16 Pit 9415 lay in the centre of the trench, and was almost circular in plan with a diameter of up to 2.6m and a depth of 0.96m (Fig. 17, Section 9402; Plate 8). The edges of the pit were near-vertical and in places slightly undercutting. At the base of the pit was a thin layer (9416) comprising dark grey silty clay with charcoal fragments, presumably dumped material. This was overlain by natural silting and episodes of slumping represented by deposits 9417, 9418 and 9419. These were sealed by fill 9421, a brownish grey, silty clay deposit with charcoal and lumps of partially fired or burnt clay throughout. It also contained charred remains of wheat and small legumes (Sample 28). The final fill (9422) was a dark grey silty clay deposit with occasional charred remains, a sample of which (Sample 29) produced bedstraw, speedwell and grass seeds. A small assemblage of 13th century pottery was recovered from deposits 9418, 9421 and 9422, and a small scrap of residual Roman pottery was also recovered from fill 9422.
- 4.9.17 Near to the east end, pit 9410 extended beyond the southern limit of the trench, but measured at least 4.7m x 3.4m in plan and was approximately 0.6m deep. It had steep, irregular sides leading down to an uneven base, and was filled by a sequence of naturally accumulated deposits: 9411, 9412 and 9413. Both 9412 and 9413 contained a relatively large assemblage of residual worked flint (19 pieces) including a high proportion of blades and bladelets. Although damaged and in poor condition, these presumably derived from an *in situ* scatter close to 9410.
- 4.9.18 On the basis of the evaluation trenches, it is difficult to determine whether the cropmark enclosure was genuine. Ditches 9306 on the north and 9409 on the east were at right angles, and could have been associated, although they were of very different dimensions, and neither was dated. No trace of a southern return was found, so on balance it seems unlikely that the enclosure was genuine, although medieval activity was clearly present in this area.

## 4.10 Trenches 95, 99 and 103-4 (Figs 4, 18 and 19)

- 4.10.1 This group of trenches were located south of Trenches 91-3 on the southern side of the valley near the base of the slope (Fig. 4). Unlike the opposite side of the valley, which continued to slope relatively steeply all the way to the bottom, these three trenches occupied a more gently sloping area that formed a slight plateau above the lowest and wettest part of the valley.
- 4.10.2 **Trench 103** was orientated NE-SW, perpendicular to the contour of the valley slope. At the north-east end, the trench was excavated to a maximum depth of 2m through colluvial and alluvial layers. No archaeological features were identified in the trench, but at the south-west end removal of the ploughsoil and a thin subsoil interface (10313) revealed a greyish olive, sandy silt deposit (10320) at a depth of approximately 0.4m.
- 4.10.3 Visible in the surface of deposit 10320 were numerous worked and burnt flints. The layer extended for 6m from the south-west end of the trench. A sample 1 square metre of this deposit was excavated to provide information on the depth of the deposit and the density of worked flint, and showed that 10320

was approximately 0.1m thick. Worked flints were found throughout deposit 10320 and were also present in the surface of underlying deposit 10315. Due to the movement of the flint through different deposits, all flints were numbered with context number 10312 but were given individual small find numbers and their positions were recorded three dimensionally. A total of 53 worked flints were recovered from Trench 103, including a broken end scraper and part of a backed bladelet.

- 4.10.4 At one point a diffuse concentration of charcoal was recorded within deposit 10320, which may represent later bioturbation.
- 4.10.5 At the north-east end of the trench a thin deposit of olive grey silt was recorded that appears to have been a continuation of 10320. In this location it was overlain by a thick humic deposit 10303 which was sealed by an oxidised orange red layer indicating an episode of *in situ* burning (Plate 10).
- 4.10.6 A discrete patch of dark grey brown silty sand (10325) lay below 10320, whose character and origin is uncertain (Fig. 19, Section 10304). Below 10320 were slopewash deposits 10315 and 10319. This general soil sequence was repeated all along the lowest lying, central portion of the valley bottom.
- 4.10.7 **Trench 104** was relocated to a position ESE of Trench 103 to expose the same contour of the slope on which deposit 10320 and its worked flints had been identified. Below topsoil and ploughsoil at a depth of 0.45m the trench revealed either a brown slightly sandy clay silt colluvium or slopewash deposit (10410) or a pale greyish olive sandy clay silt (10409, which overlay 10410 across much of the trench. In one area in the south-eastern part of the trench deposit 10409 was absent, and here layer 10413, a pale brownish grey silt with pebbles, had accumulated in its place. This deposit was interpreted as representing silting after an erosional event that had removed 10409. Deposit 10409 was up to 0.15m thick, and more generally 0.1m thick.
- 4.10.8 Deposit 10409 contained a concentration of worked flint and burnt flint both on the surface and throughout the depth of the deposit, and is interpreted as part of the same horizon as 10320. Surface collection of the visible flints suggested that the densest concentrations were in the south-east half of the trench and the first 6m of the trench at the north-west end (Plate 11). Excavation of three test pits, each 1m square, demonstrated that the flint was predominantly within deposit 10409, but in test pit ACB was also evident up to a depth of 0.1m within underlying deposit 10410. All worked flints recovered from this trench were assigned to context number 10402, except those from later features or truncations. Across the trench a total of 356 worked flints were identified, test pit ABA producing 114 worked flints, test pit ACB containing 94 worked flints and AFC yielding 61 worked flints. The assemblage included several cores, two microliths and a backed bladelet, suggesting a Mesolithic date.
- 4.10.9 Within test pit ACB near the centre of the trench, an irregular shaped feature was recorded cutting through deposit 10409 (Fig. 19, Section 10405; Plate 12). Feature 10407 measured 0.44m wide and 0.18m deep and extended approximately 0.8m in plan across the test pit. Its full extent was not exposed as it continued beyond the south-west edge of the sondage, beneath deposit 10405. It was filled with a brownish grey, sandy silt deposit (10408) with frequent charcoal flecks, burnt flint and pieces of worked flint. Due to the

diffuse character of the feature it is unclear if it was archaeological in origin or whether it derived from bioturbation of deposit 10409. It was sealed beneath deposit 10405 which appears to be a remnant of subsoil or an interface between the subsoil and upper surface of 10409. No significant charred remains were recovered from deposit 10408 (Samples 127,128).

- 4.10.10 Adjacent to 10407 was a NE-SW aligned narrow gully, 10403 that cut through layer 10405 (Fig. 19, Section 10405). It measured 0.48m wide and up to 0.34m deep with steep irregular sides and an uneven base. The two earlier fills, 10411 and 14012, were sterile sandy silts deposited by natural silting. These were overlain by 10404, a dark grey sandy silt containing oak charcoal (Sample 120) and burnt flint fragments throughout. Due to the mixed interface between 10404 and the underlying deposit 10412 it appears that deposit 10404 was either deliberately backfilled or perhaps washed into the gully during a period of flooding. Given that no *in situ* burning was evident within the trench, this deposit of burnt stones and charcoal was presumably derived from adjacent activity upslope to the south.
- 4.10.11 **Trench 99** lay east of Trench 104, and was orientated NW-SE, sloping diagonally across the side of the valley. The north-west end of the trench was excavated to a depth of 2m to expose the accumulated colluvium at the lower end of the trench. At the base of the sequence were Pleistocene deposits 9908, 9907 and 9906. At a depth of 1m below ground level these were overlain by alluvial deposit 9909 measuring 0.15m thick. Deposit 9909 was sealed beneath a layer of light bluish grey silty sand, 9905, which was also approximately 0.15m thick and was present along the entire length of the trench, overlying 9906 directly where 9909 was not present (Fig. 19, Section 9902). In the south-east end of the trench the surface of deposit 9905 was approximately 0.4m below ground level.
- 4.10.12 Similar in appearance to deposits 10320 and 10409, layer 9905 contained numerous pieces of struck flint and burnt flint fragments, almost all of which were concentrated in the south-east end of the trench. A test pit 1m square was excavated to examine the depth and density of the worked flints. Flints recovered from the surface of deposit 9905 and those excavated from test pit DAA were all assigned context number 9901 and were recorded three dimensionally. A total of 103 struck flints were recovered from this trench, and included blades, bladelets and blade-like flakes in similar proportions to those in Trenches 103 and 104, together with a crested blade, suggesting a Mesolithic date. A small sherd of middle Bronze Age to middle Iron Age pottery was also recovered from the surface of deposit 9905, but may be intrusive from the overlying deposit. Samples 140 and 143 were recovered from deposit 9905, and produced some charcoal, but no other charred remains were identified.
- 4.10.13 In the north-west end of the trench, 9905 was overlain by a dark humic deposit (9904) with a scorched surface defined by a 0.1m thick layer of oxidised sediment (9903). This was present to approximately halfway along the trench, petering out as the topography rose to the south.
- 4.10.14 **Trench 95** was situated to the north of Trench 99, at the base of the south facing valley slope. This trench was devoid of archaeological features but revealed the deep stratigraphy of colluvium and humic deposits seen



elsewhere along the valley bottom, together with a yet earlier humic deposit not clearly defined elsewhere.

4.10.15 At the base of the trench, between 1.48m and 1.83m were slopewash deposits 9507 and 9506. These were overlain by deposit 9505, a 0.2m thick layer of dark grey clay silt. Interpreted as a buried soil the sediment from this deposit was sampled for radiocarbon dating and produced a date of 8230-7240 cal BC for the soluble fraction (Beta-614813; 8870 ± 30 BP) and a date of 10500-9880 cal BC for the insoluble fraction (Beta-614814; 10290 ± 30 BP). These dates do not pass a X2 test, but suggest that the buried soil dates somewhere at the end of the late Glacial or very early Holocene period. Overlying this buried soil two B horizons 9504 and 9503 which were followed by peaty soil layers 9508 and 9502. The upper surface of 9502 (approximately 0.5m below ground level) was defined by a bright reddish brown band of burnt clay which incorporated some degraded fragments of bricks. This was sealed beneath the colluvium 9501, and the ploughsoil 9500.

## 4.11 Trenches 100, 105 and 109 (Figs 4, 20 and 21)

4.11.1 This group of trenches were located south-east of Trenches 99 and 104 in the south-east corner of Land Parcel 7a, on the lower slope of the southern side of the valley (Fig. 4).

4.11.2 **Trench 100** revealed a large recut boundary ditch running almost the entire length of the trench. Ditch 10003, the earlier phase of boundary, had a broad flat profile 2.1m wide and 0.37m deep (Fig. 21, Section 10000), and was filled with a deposit of dark reddish brown sandy silt (10004). This ditch was visible over a distance of approximately 10m from the north-west end of the trench, but beyond this was truncated by ditch recut 10005. The recut was 1.31m wide and 0.67m deep with steep sides and a narrow, rounded base. It was filled with a sequence of mixed, probably deliberately backfilled sterile deposits: 10006, 10007, 10008, 10009, 10010 and 10011. Although undated, the dark silty upper fills and crisp but irregular bioturbated edges suggest this was a relatively recent in date. Ditches 10003 and 10005 ran parallel to a historic field boundary marked on the 2nd edition OS map (Figs 4 and 20), and although lying 10m south of its digitised line, may represent this boundary or an associated field boundary.

4.11.3 At the south-east end of the trench the boundary ditch (here numbered 10019) truncated an irregular pit. Pit 10013 was 0.57m across and 0.29m deep, with steep and near-vertical sides and a pointed base (Fig. 21, Section 10002). It was filled with a mixed deposit of grey and orangey brown sandy silt (10018), from which a piece of worked flint was recovered. To the north-east of the pit was a small soilmark (10021) that was investigated as a possible pit, but was judged to be due to bioturbation.

4.11.4 Feature 10014 was recorded in plan but was not excavated; it was either a large tree-throw hole or a pit.

4.11.5 **Trench 105** was positioned to the south-west of Trench 100, and slightly further upslope. Below the ploughsoil and a thin subsoil at approximately 0.35m below ground level was deposit 10502, a compact light grey sandy silt. Deposit 10502 most resembles the flint bearing deposits recorded further to the west in Trenches 103, 104 and 99, but contained only a few worked flints,

so was removed by machine to expose the surface of 10504, a light-yellow brown, clay silt deposit overlying the natural geology, across much of the trench (Fig. 21, Section 10500). A moderate scatter of worked flints was recorded along the trench in the surface of deposit 10504 and were assigned the context number 10503. Flints were recovered by surface collection and from a 1m square test pit (CAA), resulting in a total assemblage of 61 worked flints. A fragment from a 17th century clay pipe stem was also recovered from 10503, but was presumably intrusive. No charred remains were recovered from sampling of these deposits (Samples 119, 139, 141).

- 4.11.6 **Trench 109** lay east of Trench 105 and south-east of Trench 100. Below the subsoil (10901) was 10902, a light brownish yellow sandy silt that may represent a reworked brickearth deposit. A total of 22 worked flints were identified along the surface of deposit 10902, and these were plotted with the GPS and attributed to context number 10901. Due to the sparsity of the material no further recovery of the flint was implemented.
- 4.11.7 At the south-east end of the trench layer 10902 was cut by a large irregular pit. Pit 10907 was not fully exposed within the trench, but measured up to 2.09m across and 0.53m deep (Fig. 21, Section 10901). It was filled with greyish brown, sandy silt (10908), from which two sherds of late Bronze Age or early Iron Age pottery and struck flints were recovered, and a single charred wheat grain and chaff fragments came from Sample 139. Due to the irregular nature of the feature, it is possible that this was a large tree-throw hole used for discarding waste.

## 4.12 Trenches 79, 89, 96-8 and 107 (Figs 4, 22 and 23)

- 4.12.1 This group of trenches were located south-east and north-east of Trench 94 in the east of Land Parcel 7a, on the lower, south facing slope of the valley (Fig. 4). Trench 97 was rotated from its original position by 90 degrees to provide a longer transect down the slope, aligned with Trench 88.
- 4.12.2 In the northern end of **Trench 96** was a sub-circular pit, 9606. It measured at least 0.94m in length, 0.5m wide and was up to 0.54m deep (Fig. 23, Section 9600). Filling the base of the pit was a dump of burnt material (9607) comprising reddish brown silty clay with charcoal and fired clay fragments throughout, including three fragments of a triangular oven brick of Iron Age (or early Roman) type. The charcoal in deposit 9607 comprised oak, elm, hazel and possible alder (Sample 42). This was overlain by a more sterile, brownish grey silty clay, 9604. The northern part of the pit was truncated by ditch 9603, which ran on an ENE-WSW alignment across the trench. Ditch 9603 was approximately 2m wide and 0.26m deep and so had a very wide, shallow profile. It was filled with a greyish brown, silty clay deposit (9605), with a lens of charcoal present along the south-west edge of the feature. Ditch 9603 may have continued eastwards as ditches 9709, 9806 and 10720.
- 4.12.3 Overlying deposit 9605 was a stony colluvium, 9601 and the ploughsoil, 9600. At the southern end of the trench was a more complex sequence of colluvial deposits which included 9609, a humic, buried soil horizon with a burnt upper surface (9608), a deposit sequence that appears to be present across all trenches in this part of the valley base. Due to flooding at the lower end of the

trench, these colluvial deposits could not be recorded in detail, but were in the adjacent Trench 97.

- 4.12.4 **Trench 97** was approximately 30m to the east of Trench 96. At the northern end it revealed ditch 9709 running ENE-WSW, which was not excavated as it was in line with ditch 9603, and was almost certainly a continuation. This was cut through colluvial deposit 9708=9711. A small scrap of late Bronze Age pottery was recovered from the surface of this colluvium.
- 4.12.5 The southern end of the trench was excavated to a depth of 2m, revealing several slopewash deposits believed to be of Pleistocene date. Approximately 0.7m below ground level, these deposits were overlain by pale olive, clayey silt layer 9703. This deposit extended around 18m northwards from the southern end of the trench. Between 9m and 18m from the southern end of the trench numerous worked flints were recovered from the surface of deposit 9703. These were all recorded three dimensionally and attributed to context number 9705 as a possible *in situ* scatter. A single test pit (EAA) was excavated in spits through the deposit to a depth of 0.25m to establish the depth and density of the flints (Fig. 23, Section 9703; Plate 13). A total of 102 worked flints were recovered from the trench, including a double microburin suggesting that the assemblage included a Mesolithic component. No significant charred remains were recovered from sampling undertaken during the excavation of the spits.
- 4.12.6 Overlying layer 9703 was a dark humic deposit (9702) with a burnt upper horizon, equivalent to layers 9609 and 9608 in Trench 96, which was recorded in detail.
- 4.12.7 **Trench 98** lay ENE of Trench 97 and revealed a similar sequence of deposits and features to both Trenches 96 and 97, with a slightly deeper sequence at the lower end. At the southern end of the trench deposit 9811 was overlain by colluvium 9810 and a small sherd of possibly early Iron Age pottery was found at the interface between these two deposits. Layer 9810 was then sealed by a light grey olive silt (9809/9803) which was present along much of the trench. A dark humic silt, 9805 had then formed over the surface of 9809/9803. As seen elsewhere along the valley base, the surface of deposit 9805 was burnt and oxidised forming a pinkish red horizon, here numbered 9808. Although deposit 9809/9803 appears stratigraphically to be the same layer as that seen further west across the valley base containing *in situ* flint scatters, only five pieces of worked flint were recovered from this horizon in Trench 98.
- 4.12.8 Ditch 9806 at the northern end of the trench was orientated ENE-WSW, and was in line with ditches 9709 and 9603, and was clearly a continuation of the same boundary. It contained a single fill brownish grey silty clay (9807) which produced 37 pieces of residual worked flint and a sherd of medieval pottery. These artefacts are most likely to be derived from colluvium 9802, through which the ditch was cutting, which also produced 13th century pottery.
- 4.12.9 **Trench 89** was located to the north of Trench 98, on a break of slope forming a slight plateau halfway up the south facing side of the valley. Excavated to a depth of 2m, the trench exposed several layers of Pleistocene slopewash. At a depth of 1.26m below ground level, these were overlain by colluvium 8903 which was approximately 0.4m thick.

- 4.12.10 Although ditches 8909 and 8911 were truncated during machining, they were both cut into colluvium 8903 at a depth of around 0.8m below ground, and had shallow concave profiles and were filled with identical deposits of light-yellow grey, sandy silt. Their similar character may indicate that they formed the corner of an enclosure, though there was no dating for this. A small circular pit, 8913 was also recorded at this horizon and was filled with a very similar deposit, 8914. A piece of worked flint was recovered from the fill of this pit. These features were sealed beneath colluvial layer 8902, and this and overlying subsoil 8901 both contained small sherds of later prehistoric pottery, while 8902 also contained burnt flint.
- 4.12.11 **Trench 107** was positioned to the east of Trench 98, against the eastern edge of Land Parcel 7a. It was excavated to a maximum depth of 2m and revealed a complex sequence of colluvial deposits and several phases of activity. The earliest deposits exposed were a succession of slopewash deposits. These were sampled in two parts of the trench, and in one part were labelled successively 10717, 10716 and 10709, and elsewhere 10714, 10713 and 10712. Numbers 10712 and 10709 were given to the interface between the underlying deposits and layer 10708 above.
- 4.12.12 Near the north-east end of the trench, slopewash deposit 10716 was cut by a pair of possible pits, 10700 and 10731. Pit 10700 was sub-circular in plan with a diameter of 0.83m and was 0.32m deep with a concave base. It appeared to have been deliberately backfilled with deposits 10701 and 10702, both of which contained charcoal throughout, while 10702 also contained some fragments of burnt clay, but produced little identifiable charred material from Sample 40. The upper fill of the pit was sterile, brown sandy silt deposit 10704. Because it was distinct from the underlying fills this was initially recorded as the fill of a later feature (10703) but was more probably a fill of pit 10700.
- 4.12.13 The adjacent pit, 10731 was much more irregular in plan and extended into the north-west baulk of the trench. It had a primary fill comprising sterile light grey sandy silt (10737), with a distinct dump of charcoal-rich silt (10732) overlying it and concentrated in the southern end of the feature. Given the irregular and meandering appearance of 10731 it is likely that this was a tree-throw hole. It is therefore also possible that adjacent pit 10700 was in fact a continuation of the same tree-throw hole, but had been truncated and separated during machining.
- 4.12.14 Approximately 2.5m to the south-west were pits 10729 and 10725. These were also cut through deposit 10716/10713 and were overlain by colluvium 10708. Pit 10725 was not fully exposed within the trench, but the exposed part was 0.9m wide and at least 0.22m deep with steep sides, though it was not bottomed (Fig. 23, Section 10707). It had a sterile lower fill of silty clay (10727) overlain by a mixed deposit (10726) consisting almost entirely of elm and hazel charcoal (Sample 135) and burnt silty clay. Pit 10729 was left unexcavated and had an upper fill of grey silty clay with occasional charcoal flecks.
- 4.12.15 Posthole 10723 was recorded approximately 2.5m to the south-west of pit 10725. Although not particularly clear, it appeared to be cutting through deposit 10712, a light grey slopewash deposit that elsewhere along the trench formed an interface between 10708 above and 10713 below. The posthole

measured 0.52m in diameter and was 0.91m deep with near vertical sides leading to a rounded base (Fig. 23, Section 10706). Deposit 10722 represented the backfilling of the posthole and consisted of a light grey sandy clay material. This surrounded the remnants of the post itself, which was identifiable as a very dark (almost black) humic deposit 10724 that measured 0.22m wide and 0.49m deep. The upper portion of the post-pipe was a grey silt (10728) that was evidently derived from the surrounding backfill. Environmental sample 133 from 10724 produced anaerobically preserved wood fragments demonstrating that this was actually the remains of the post. Whilst the feature is undated, its stratigraphic position would suggest that it was not a recent construction and highlights the potential for preservation on the site.

- 4.12.16 As a result of the machining, it was not possible to be certain which deposit sealed posthole 10723. However, all the other pits and the possible tree throw to the north-east were sealed beneath deposit 10708. This was an olive grey silt present across much of the trench and contained 29 pieces of worked flint, including a large blade potentially of late Upper Palaeolithic date. Other key finds from the assemblage include a large adze/axe sharpening flake and four cores. A single sherd of early Roman pottery was also found on the surface at this horizon, but as a single fragment it may have been moved during excavation.
- 4.12.17 Near the centre of the trench deposit 10708 was truncated by ditch 10718, recut as ditch 10720 (Fig. 23, Sections 10708/10705). Ditch 10718 was at least 1.13m wide and was 0.85m deep with a very steep side and a flattish base, while recut 10720 was about 1.20m wide and 0.97m deep, although due to settling of the fills the top of both ditches was filled by the overlying subsoil 10707. These were both orientated E-W and their projected line lay slightly north of ditch 9806 to the west, but were probably a continuation of the same boundary.

## 4.13 Trenches 113, 120 and 126-7 (Figs 4, 24 and 25)

- 4.13.1 Trench 113 lay in the western part of Land Parcel 7b, while Trenches 120, 126 and 127 were located towards the eastern end, more than 300m away from the nearest archaeological activity on Land Parcel 7a. All these trenches were positioned on the south facing slope of the valley, overlooking Land Parcels 7c and 8 to the south and south-east (Figs 4 and 5).
- 4.13.2 **Trench 113** contained buried soil 11303, from which both 11 struck flints and a sherd of later prehistoric (MBA-MIA) pottery were recovered. The flint was in good condition, and included two flakes from the same nodule, suggesting that it was little disturbed. Five blades suggest an early date, perhaps Mesolithic like the scatters in Land Parcel 7a to the west. Struck flints also came from the overlying colluvial layer 11302. The surrounding trenches did not produce any archaeological features, although evidence of activity further upslope was evident in burnt flint from colluvial layer 11001 in Trench 110. Probably Roman CBM was recovered from colluvial layer 11601 in Trench 116, and a scrap of unidentifiable pottery from colluvial layer 11602.
- 4.13.3 **Trench 120** exposed a single ditch orientated on a NE-SW alignment running downslope perpendicular to the orientation of the valley, and down the centre

of the trench. Ditch 12007 was 1m wide and 0.4m deep with steep straight sides and a rounded base (Fig. 25, Section 12001). It was filled with a single deposit of grey reddish brown, silty clay, 12008. A small piece of worked flint was recovered from the fill of this ditch.

- 4.13.4 The south-west end of the ditch appears to have been truncated during machining and presumably was not visible at this time, perhaps becoming shallower as the natural topography sloped down the valley side.
- 4.13.5 **Trench 126** lay nearly 100m east of Trench 120, and revealed the base of a small tree-throw hole (12604). It was approximately 0.35m in diameter and 0.07m deep with an uneven base and a single fill of dark brown sandy silt (12605). Several flint flakes were recovered from the fill.
- 4.13.6 **Trench 127** was located east of Trench 126 at the far eastern end of the parcel. Below ploughsoil and successive layers of colluvium a burnt pit was exposed (Plate 14). Pit 12706 was sub-ovoid in plan with its long axis aligned NW-SE, and measured 1.78m long, 1.1m wide and survived up to 0.5m deep, with sloping straight sides and a rounded base with a slight ridge in the middle (Fig. 25, Section 12702). The pit contained a charcoal-rich fill (12707) across the base and up the sides of the feature that was up to 0.2m thick. The inner face of this layer was a reddish-brown colour indicating oxidation and *in situ* burning, but no such evidence was visible at the interface with the natural. Overlying 12707 were several silty sand deposits with some charcoal (12708, 12710 and 12709), which had been deliberately deposited. These were overlain by another charcoal-rich band (12712), succeeded in turn by a final backfill of greyish brown silty sand (12711). Sample 132 was recovered from deposit 12707 and produced a charcoal rich flint of both hazel and apple/hawthorn. None of the fills produced finds.
- 4.13.7 The character of the burning does not suggest that this was a kiln or oven, in both of which more reddening of the edges of the feature occurs. It may suggest that the feature was filled with wood that was then set alight and which burnt rapidly, so that the heat did not last for long enough to redden the edges of the feature, but as the wood burnt down the surface of the resulting charcoal was exposed to the air and so was reddened, while the charcoal underneath remained black. Flash-firing of storage pits to remove adhering germinated grain sometimes produces a similar result, but in this case the environmental sample produced only charcoal.

#### 4.14 Trenches 138-9 and 141 (Figs 5, 26 and 27)

- 4.14.1 This group of trenches was located in the north-west corner of Land Parcel 7c, at the base of the slope which rose gently to the south and south-west (Fig. 5).
- 4.14.2 **Trench 138** was aligned NE-SW following the slope of the topography, and revealed several pits and a larger irregular feature. The features in Trench 138 were cut through a possible Head deposit (13804) which was present across much of the base of the trench, and were sealed beneath colluvial layers 13803 and 13802.
- 4.14.3 Pits 13813 and 13808 were revealed near the south-west end of the trench. Both extended beyond the limits of the trench, but appeared to be sub-circular in plan and around 0.3m deep, with flattish but uneven bases (Fig. 27, Section

- 13803). Pit 13813 was the earlier, and was filled with greyish blue clayey silt 13814, from which two small sherds of middle Bronze Age to middle Iron Age pottery and worked flint were recovered. It was truncated on its northern side by pit 13808. This later feature had sloping sides, and was filled with a very dark grey clay silt deposit (13809) rich in charcoal and burnt flint (Plate 15). Several worked flints were also found in this deposit, and environmental Sample 190 produced an indeterminate grain fragment as well as charcoal.
- 4.14.4 Pit 13806 was located 5.5m to the north-east of 13808. It was circular in plan with a shallow concave profile, 0.42m wide and 0.08m deep. It contained a deposit of light grey brown, silty clay with charcoal flecks and burnt flint. No finds were recovered from this feature, and environmental Sample 180 produced only a very little charcoal.
- 4.14.5 Immediately adjacent to pit 13806 was a large area of poorly defined disturbance. Recorded as a possible tree-throw hole (13810) the affected area measured 5.2m in length (NE-SW) and in excess of 2m wide although the overall shape in plan was very irregular. The sides of the feature were steep but uneven, as was the base, and the feature was 0.36m deep. Feature 13810 was filled by a mixed light yellow-brown and reddish brown silty clay (13811) with patches of sandy silt. Throughout the fill were moderately frequent charcoal flecks and some burnt stone fragments. An assemblage of 16 pieces of worked flint were recovered from this deposit, including an obliquely blunted microlith. Based upon the mixed character of the fill, these finds presumably arrived during deliberate backfilling.
- 4.14.6 **Trench 139** was positioned immediately to the east of Trench 138, and revealed further pits and tree-throw holes. The features were dug into colluvial layer 13902, which contained several worked flints, particularly towards the lower, north-east end of the trench.
- 4.14.7 Pit 13904 was revealed in the north-east end of the trench. It was only partially exposed but appeared to be oval in plan measuring up to 0.62m wide and 0.64m deep, with steep sides and a rounded base (Fig. 27, Section 13901). The two lower fills 13909 and 13906 were homogenous clean deposits of silty clay. The upper fill, 13905 was a mixed deposit of orangey grey, clay silt with burnt clay and charcoal flecks throughout, although little charred material was recovered through sampling (Sample 187). This clearly represents a dump of material and included an impressive assemblage of 59 worked flints, including a long blade of potentially late Upper Palaeolithic date and a microlith.
- 4.14.8 Ditch 13907 was orientated on a linear NW-SE alignment, and measured 0.34m wide and 0.24m deep with a concave base and steep sides (Fig. 27, Section 13903). It contained a single deposit of light orange-grey, silty sand (13908), which was without finds. No continuation of this ditch was seen in Trench 138 to the north-west, though its projected line was within the area of feature 13911, which may have truncated it.
- 4.14.9 Feature 13911 was an irregular tree-throw hole. Its lower fill (13912) was a mid grey-blue, clayey silt, with concentrations of charcoal fragments, and this was overlain by a light yellow, clayey silt 13913, which also contained a moderate amount of charcoal flecks. Worked flints were recovered from both deposits. These deposits were sampled (Samples 188 and 189 respectively) but failed to produce any significant charred remains.

- 4.14.10 **Trench 141** was located to the south-west of Trench 138, was orientated WNW-ESE and contained a pit and an irregular feature at the east end. Both 14109 and pit 14107 were apparently sealed beneath colluvium or possible buried soil 14104. This was a brownish grey silty sand with charcoal and burnt flint present throughout. It also contained a small sherd of middle Bronze Age to middle Iron Age pottery and four flint flakes of Neolithic or later date.
- 4.14.11 Pit 14107 was a small circular feature 0.36m in diameter and 0.12m deep with a sloping sides and a rounded base (Fig. 27, Section 14101). It had a fill (14108) of dark grey, clayey silt with charcoal flecks, some pottery fragments and several pieces of worked flint including a circular scraper of later Neolithic or early Bronze Age date. The pottery was tentatively dated as early Neolithic but could also be later prehistoric.
- 4.14.12 Cut 14109 north of pit 14107 was an irregular feature of potentially natural origins. It was at least 0.4m deep and contained a fill of light grey and brown clayey silt (14110) that produced an assemblage of 31 worked flints and two sherds of early Roman pottery. It is possible that this was the remains of a tree-throw hole, or perhaps a gully that had washed the artefacts through the underlying colluvium, especially given the mix of artefact types and date.

## 4.15 Trenches 140 and 162-168 (Figs 5, 28 and 29)

- 4.15.1 This cluster of trenches was located in the centre of the northern edge of Land Parcel 7c and only 40m south of the pond in Land Parcel 7b that marks the very base of the valley (Fig. 5). The trenches lay in and around a slight depression that formed the lowest point on Land Parcel 7c, from which the land sloped upwards to the east, south and west.
- 4.15.2 **Trench 140** lay at the north-west edge of the group, and revealed a large pond-like feature at its northern end (Plate 16). Originally identified during geoarchaeological work in the trench, the sides of the excavation became too unstable to allow further investigation and recording beyond photographs and a sketch section. Overall, feature 14003 was approximately 7m long (N-S) and up to 1.5m deep with steeply sloping sides demonstrating that it was not a natural feature. It was filled with dark grey, clay silt deposits 14007 and 14010/14004, both of which showed evidence of gleying and therefore suggest that the feature was waterlogged. No finds were recovered from this feature.
- 4.15.3 **Trench 163** lay south of Trench 140, and revealed several small linear features. The features in this trench cut through 16308, a fine slopewash deposit and were overlain by stabilisation layer 16302. Based on their similar appearance and fills they are likely to be broadly contemporary, perhaps forming part of a small enclosure or field system.
- 4.15.4 Ditch 16313 was aligned SW-NE, and was 0.58m wide and 0.1m deep with a shallow concave profile (Fig. 29, Section 16305). It was filled with sterile, greyish brown silty clay 16314. In the north-east corner of the trench ditch 16311 was aligned NW-SE at right angles to ditch 16313, and may have been associated. It measured 0.4m wide and 0.24m deep with steep sides and a rounded base. Its fill (16312) was similar to 16314, and contained worked flints.



- 4.15.5 Between these ditches on the west side of the trench ditch terminus 16309 was aligned roughly east-west. This ditch measured 0.63m wide and 0.24m deep and had steep sides and a rounded base (Fig. 29, Section 16302). It contained a deposit of light grey, clay silt (16310) which produced pieces of worked flint and pottery of either early Neolithic or middle Bronze Age to middle Iron Age date.
- 4.15.6 An irregular feature (16315) lay between ditches 16309 and 16311, and its fill (16316) also contained several pieces of worked flint and a tiny fragment of prehistoric pottery. This was probably a tree-throw hole.
- 4.15.7 **Trench 164** was located to the south-east of Trench 163 and revealed a ditch of similar dimensions to those in Trench 163, in this case aligned ENE-WSW. Ditch 16413 was up to 0.57m wide and 0.17m deep with steep sides and a concave base (Fig. 29, Section 16402). The ditch had a sterile fill of light grey silty clay and is therefore undated. It is, however, in line with ditch terminus 16309, and its similar character suggests that it is part of the same ditch system.
- 4.15.8 Pit 16410 was situated on the northern edge of ditch 16413 and was recorded as earlier than the ditch, although the overlap between them was slight (Fig. 29, Section 16402). The pit measured 0.82m wide and 0.19m deep. Its primary fill (16411) was overlain by a charcoal-rich deposit (16412) that consisted of grey brown silty clay with pieces of degraded fired clay throughout. No dating evidence was recovered, but Sample 177 from fill 16412 produced both charcoal and charred grain.
- 4.15.9 A large irregular soilmark was also partly exposed further east along the trench, and was judged to be a tree-throw hole, so was not excavated.
- 4.15.10 **Trench 162** lay south-east of Trench 140 and north-east of Trench 163, and revealed a ditch aligned NNE-SSW. The ditch was 1.5m wide with a dark yellowish brown sandy silt fill, but was not excavated. The projected line of this ditch just missed Trench 164, but a probable continuation of this ditch was seen in Trench 166 further south-west, and this ditch (16609) was excavated, and contained a piece of clay pipe.
- 4.15.11 **Trench 166** lay south of Trench 163, and revealed a ditch and a pond. Ditch 16609 was on a NNE-SSW alignment and crossed the northern part of the trench. It was 0.72m wide and 0.22m deep with steep sides and a flattish base (Fig. 29, Section 16602), and a clay pipe bowl dated 1780-1830 was recovered from single fill 16610. A probable continuation of this ditch was seen in Trench 162.
- 4.15.12 In the south-east corner of Trench 166 was a large cut interpreted as the remains of a pond. Due to the instability of the excavation edges it was not possible to record this feature in detail, but it measured approximately 12m wide (N-S) and 0.6m deep. It was filled with a greyish brown sandy clay sediment (16608), but did not provide any dating evidence. Although it lies some 10m further north-east, this pond may correspond to one marked on the 2nd edition OS map of 1898 against the eastern boundary of a field. If this is correct, the eastern field boundary would also be in line with ditches 16609 and 16205.

- 4.15.13 **Trench 165** lay east of Trench 164, and revealed a ditch aligned NNE-SSW directly beneath the ploughsoil. Ditch 16505 was just over 2m wide and 0.65m deep, and was filled with a dark grey brown humic deposit suggesting a relatively recent boundary. This was excavated by machine, and there were no finds. A continuation of this ditch was seen in Trench 168 to the south.
- 4.15.14 **Trench 168** contained a ditch of very similar proportions to ditch 16505 at its west end, running on an almost N-S alignment. Ditch 16806 was also excavated by machine and was filled with a dark greyish brown sandy silt, again without finds. Although it does not appear on historic mapping, it is parallel to the ditch crossing Trenches 162 and 166 to the west, and (allowing for the adjustment to the relative position of the 19th century map as discussed in relation to Trenches 162 and 166 above) is in line with a field boundary then existing to the south. It is likely that ditches 16505 and 16806 represent a former continuation of this boundary.
- 4.15.15 **Trench 167** lay south of Trench 164 and between Trenches 166 and 168, and below the topsoil and subsoil revealed two irregular features and a ditch cut into a sequence of colluvial deposits (16702-16704). Ditch 16707 was orientated ENE-WSW at the southern end of the trench, and was 3m wide and 0.58m deep with gently sloping sides and a flattish base. Allowing for the shift in the relative position of the 2nd edition OS map, ditch 16707 matches the position of a field boundary shown on this map marking the southern edge of an area of woodland marked as 'Highash Shaw', and whose western boundary was defined by the ditch crossing Trenches 162 and 166.
- 4.15.16 North of ditch 16707 two large irregular features (16713 and 16710) were partly exposed on the west side of the trench. Tree-throw hole 16713 was around 3m N-S and at least 1.6m E-W, and was 0.15m deep. Its single fill (16714) produced fired clay fragments, struck flint and animal bone. Tree-throw hole 13710 was centred around 11m north of 13713, and was also around 3m N-S and at least 1.36m E-W. The feature was 0.4m deep and had two fills, both of which produced a single flint flake.

## 4.16 Trenches 170 and 174-6 (Figs 5, 30 and 31)

- 4.16.1 Trenches 174, 170, 175 and 176 were located east of Trench 168 in the north-east corner of Land Parcel 7c (Fig. 5), at the lower end of the north facing valley slope.
- 4.16.2 **Trench 174** was located at the western edge of this group. It revealed a small pit, 17404 in the east facing section of the trench, measuring 0.4m wide and 0.3m deep sealed by topsoil and ploughsoil and cutting colluvial deposits (Fig. 31, Section 17400). It contained a deposit of yellow brown silt with charcoal-rich patches throughout and concentrated towards the base. No finds were recovered from this feature. (Sample 153) produced ring-porous charcoal including oak.
- 4.16.3 **Trench 170** was positioned to the north-east of Trench 174 in the wettest part of the site, and revealed a ditch aligned N-S. Ditch 17006 measured 1.41m wide and 0.3m deep with a broad uneven base, and was filled with a dark greyish brown silty clay (17007). Sample 174 was taken to assess waterlogged preservation, but although water flea was found, confirming that the deposit had held water for most of the time, there were few other

waterlogged remains. Although some small CBM fragments were identified in the fill, the waterlogged nature of the deposits meant they were too degraded and fragile for recovery.

- 4.16.4 **Trench 175** lay south of Trench 170 and revealed a complex concentration of pits and ditches, almost all of which were cut through slopewash deposit 17506 and were sealed by colluvial layer 17502. At the west end of the trench a short length of ditch aligned NNE-SSW, and possibly curving, was exposed, cut on the north by a later ditch aligned ENE-WSW. Ditch 17515 measured 0.8m wide and 0.32m deep with very steep sides and a flattish base (Fig. 31, Section 17503). It was filled with a deposit of blue grey silty clay (17510) suggestive of gleying, from which came a scrap of prehistoric pottery, animal bone and worked flint. Sample 178 was taken from the fill, but did not produce charred remains.
- 4.16.5 The northern end of ditch 17515 was truncated by WSW-ENE aligned ditch 17503. This was a steep-sided feature with a rounded base measuring 1.23m wide and 0.43m deep (Fig. 31, Section 17503). It contained a single fill of mottled brown-grey and orange silty clay (17504), and several pieces of worked flint and four sherds of middle Iron Age pottery were recovered from this naturally accumulated deposit.
- 4.16.6 At the very western end of the trench was a cluster of small pits: 17511, 17512, 17513 and 17514. These ranged between 0.45m and 0.66m in diameter, although none were fully exposed in plan, and all four pits had similar mid grey sandy silt fills suggesting that they were broadly contemporary, although the slightly gleyed appearance of these deposits, as with the fills of ditches 17515 and 17503, may indicate post-depositional changes caused by groundwater.
- 4.16.7 At the eastern end of the trench were a series of intercutting features. Stratigraphically, the earliest of these appears to have been ditch 17516, a N-S aligned feature visible in the lowest step of the trench cutting through deposit 17506 (Fig. 31, Section 17504; Plate 17). It measured 1.18m wide and at least 0.85m deep based on the exposed remains, but due to later truncations its overall original dimensions could not be determined, though the base of the feature was approximately 1.25m below the existing ground level. Ditch 17516 contained a sequence of naturally silted deposits commencing with 17517, a primary fill of dark grey silty clay. This was overlain by the dark blueish grey clay of 17518, a lighter grey clay deposit, 17519 and an upper fill of mottled orange and grey silty clay, 17526. The colour and gleyed appearance of these deposits indicate that water was frequently present. Deposit 17519 produced three flints including a fragment of a microdenticulate blade.
- 4.16.8 Two small pits, 17524 and 17527 cut through the upper fill of ditch 17516 (Fig. 31, Section 17504). These were 0.43m and 0.79m in diameter and 0.3m and 0.27m deep respectively, with steep sides and flat bases. Both had filled with similarly sterile, naturally silted deposits comprising greyish blue, sandy clays.
- 4.16.9 Also cutting through layer 17506 was a large irregular feature, 17521. It measured at least 4m across and up to 1.2m deep. The lowest fill 17522 was a highly mixed deposit of grey silty clay and orangey brown clay silt with small flecks of CBM and charcoal throughout (Fig. 31, Sections 17504 and 17505; Plate 18). This was clearly a deliberately backfilled deposit into the base of this large feature. Overlying this was a more slowly, naturally accumulated

deposit of mid grey silty clay (17531). The upper horizons were particularly diffuse, presumably a result of the feature being left open, but it appears that the very top filled with colluvium 17502 seen right across the trench.

- 4.16.10 The final feature at the east end of the trench was a large pit or perhaps a ditch terminus, 17520 (Fig. 31, Section 17505). It was recorded as cutting through colluvium 17502, but this was a tentative interpretation and the relationship between 17520 and this layer is highly bioturbated as a result of worm and root activity. The full extent of the feature was also not clear and it was not possible to excavate to the base of the feature due to its location in the trench. The visible portion measured 1.92m wide and 0.35m deep with an upper fill of greyish blue and orangey brown silty clay. No finds were recovered from this feature.
- 4.16.11 **Trench 176** was located to the east of Trench 175 and revealed several ditches and pits. Running ENE from the west end for much of the length of the trench was ditch 17611. It was up to 0.6m wide, but where sectioned was only 0.36m wide and 0.2m deep with steep sides and a rounded base (Fig. 31, Section 17602). The fill was a light grey clayey silt (17612), from which a single piece of worked flint was recovered.
- 4.16.12 Towards the east end of ditch 17611 it intersected with two diffuse linear features filled with sterile light grey silt. Feature 17613 was aligned NW-SE and 17616 orientated WNW-ESE, and they were approximately 0.32m wide by 0.19m deep and 0.43m wide and 0.12m deep respectively. These may be the remains of small ditches or gullies, but neither had distinct edges either in section or plan, and they may instead be natural variations in colluvium 17605, which was the deposit at the base of the trench through which the other features were cut.
- 4.16.13 Near the centre of the trench, west of feature 17613 and south of ditch 17611, was a shallow oval pit (17615) containing the remains of a crouched inhumation (17622). The pit measured 1.22m x 0.82m in plan and survived just 0.13m deep. The remains were particularly badly preserved and only a fragment of the mandible survived along with the large bones of one leg and one arm (Plate 20), but were sufficient to indicate that the body had been placed facing east with the head to the south. It was backfilled with light orangey grey, sandy silt 17621 which included five small sherds of possible early Neolithic or middle Bronze Age to middle Iron Age pottery and six flints, including a retouched flake found near the femur of the individual. It is however unclear if this flint was placed deliberately or incorporated as part of the backfill. Seven flints in good condition were recovered from the surface of deposit 17620 through which this pit was cut, so there is a good possibility that the flints were residual.
- 4.16.14 At the eastern end of the trench were two sub-circular pits backfilled with burnt debris. Pit 17604 was nearly 1m across and 0.34m deep with very steep sides and a flat base, and following primary silting (17605) was filled with a dump of orangey brown clayey sand (17606) with burnt stones and almost 2kg of fired clay fragments that appear to have come from an oven or similar structure (Plate 19). Sample 129 was taken from fill 17606 but produced only undiagnostic charcoal flecks. Pit 17607 was at least 0.5m across and 0.2m deep, and was filled by dark brown clay sand (17609) containing fragments of

fired clay and charcoal. Sample 130 indicated that the charcoal included oak and hazel.

#### **4.17 Trenches 149-50 and 152 (Figs 5, 32 and 33)**

- 4.17.1 This group of trenches were located south-west of Trenches 166 on the west edge of the evaluated area of Land Parcel 7c and at the base of a gently graded slope that rises to the west (Fig. 5).
- 4.17.2 **Trench 149** lay south of sterile trench 148, and was the northernmost of this group of trenches. It revealed a shallow colluvium (14902) overlying the natural geology 14904/14906. A small piece of late Bronze Age to early Iron Age pottery and a worked flint were recovered from the surface of 14904 at the interface with overlying colluvium 14902. This was truncated by a NE-SW aligned ditch. Ditch 14905 measured 0.74m wide and 0.14m deep and had steep sides and a concave base (Fig. 33, Section 14900). It contained a primary fill (14907) overlain by a gradually silted deposit of sandy silt (14908). Three sherds of Roman pottery were recovered from the upper fill.
- 4.17.3 **Trench 150** was located immediately to the south of Trench 140 and contained two ditches. Ditch 15005 was orientated NNW-SSE, and was 0.73m wide and 0.13m deep (Fig. 33, Section 15001), while 15003 was 0.85m wide and 0.23m deep (Fig. 33, Section 15000). Both had shallow concave profiles and gently sloping sides, and were filled with yellowish brown sandy silt (fills 15004 and 15006 respectively), both of which contained worked flint.
- 4.17.4 **Trench 152** was approximately 70m to the south of Trench 150 and revealed multiple ditches and pits. Pits 15213 and 15209 extended beyond the southern limit of the trench but were broadly circular in plan. Pit 15213 was 1.06m across and 0.28m deep, and contained a sterile fill of orangey brown sandy clay (15214) that was presumably derived from the surrounding geology. Adjacent pit 15209 was larger, measuring 1.2m across and 0.43m deep with steeply sloping sides and a rounded base (Fig. 33, Section 15204), and had a more distinct, dark brown, sandy clay fill (15210), from which a little worked flint was recovered. Sample 179 of fill 15210 only contained a small amount of charcoal, so the dark colour presumably indicates former organic content.
- 4.17.5 Ditch 15204 was aligned NE-SW, and measured up to 1.33m wide and 0.35m deep with a broad, slightly concave profile. It was filled with homogenous deposits of sandy clay 15205 and 15215. The upper fill, 15205 contained several pieces of worked flint.
- 4.17.6 Ditch 15211 was just over 9m to the east of 15204, on a parallel alignment. It had steep sides and a flat base measuring 0.7m wide and 0.26m deep (Fig. 33, Section 15205). It contained a sterile fill of greyish brown, sandy clay, 15212.
- 4.17.7 Ditch 15206 was only partially visible at the eastern end of the trench, but appeared to be aligned NW-SE. It was at least 1.24m wide and 0.38m deep with slightly irregular sides leading to a flattish base (Fig. 33, Section 15203). It was filled with two deposits of sterile, silty sand (15207 and 15208).

## 4.18 Trenches 178-9, 182-4 and 187 (Figs 5, 34 and 35)

- 4.18.1 This group of trenches were located east of Trenches 149 and 150 in the eastern half of Land Parcel 7c (Fig. 5). In this location the ground sloped gently downwards to the north.
- 4.18.2 **Trench 178** revealed numerous ditches on a variety of different alignments. At the west end of the trench ditch 17805 was aligned NW-SE and measured 0.58m wide and 0.16m deep with a shallow concave base (Fig. 35, Section 17801). It contained a light greyish brown fill (17806) that produced several sherds of pottery dating from the 12-13th centuries. Adjacent ditch 17803 was aligned roughly N-S, and had a similar profile and dimensions to 17805, but was filled with a dark reddish brown silty sand fill (17804). Five small sherds of Iron Age pottery were recovered from this ditch.
- 4.18.3 Ditch 17813/17815 appears to terminate within the trench but was in fact slightly over-machined and was visible in both sections of the excavation. It measured approximately 0.6m wide and 0.3m deep with naturally accumulated fills. Dating evidence in the form of some small scraps of late prehistoric pottery was recovered from fills 17816 and 17817 whilst cleaning the south facing section of the trench.
- 4.18.4 Ditch 17820 was a large NE-SW aligned feature. It was 1.2m wide and at least 0.28m deep with a fill of orangey brown sandy clay (17821) that included fired clay and charcoal fragments, and small sherds of middle Bronze Age to middle Iron Age pottery. Based on the position and alignment of this ditch it is likely that it continued into Trench 182 where it was recorded as ditch 18203 (Figs 5 and 34).
- 4.18.5 At the east end of the trench was a sub-circular pit, 17807. It measured up to 1.25m in diameter and 0.4m deep with vertical straight sides leading to a flat base. It contained a sequence of mixed and varied deposits that indicate it was deliberately backfilled after use (Fig. 35, Section 17802; Plate 21). Deposit 17811 was an orangey grey, silty clay that contained several sherds (73g) of middle Iron Age pottery. This was overlain by deposit 17809, a dark grey silty clay and by 17808, a greyish brown silty clay. These fills also produced several sherds of Iron Age pottery and fired clay fragments were present throughout the pit. Some charred wheat grain was recovered from Sample 131 taken from fill 17808.
- 4.18.6 **Trench 179** lay east of Trench 178, and revealed a small ditch at the southern end of the trench. Ditch 17905 was 1.18m wide and 0.49m deep with steep sides and a rounded base (Fig. 35, Section 17902). It was filled with two deposits of natural accumulated silty clay (17908 and 17909). No dating evidence was recovered from either. Based on its location, ditch 17905 may have been a continuation of 18005 in Trench 180 to the east (Fig. 5).
- 4.18.7 **Trench 182** lay south-west of Trench 178, and revealed a single ditch at the west end. Ditch 18203 was orientated NE-SW, and was 1.18m wide and 0.3m deep with sloping sides and a flat base. It contained a single fill (18204) which produced a struck flint. The projected line of this ditch to the north-east matches the position of ditch 17820, which is of similar dimensions, so despite having a slightly different orientation this ditch may be a continuation.

- 4.18.8 **Trench 183** was located to the east of Trench 182. Near the centre of the trench was a broadly E-W aligned ditch. Ditch 18303 measured 1.8m wide and 0.4m deep with an irregular profile (Fig. 35, Section 18300). It was filled by 18304, a greyish brown silty sand with flecks of fired clay and charcoal as well as some 20 sherds (80g) of middle Iron Age pottery and worked flint. It appears to have truncated a NNE-SSW aligned ditch, 18305 that ran in from the south. This earlier feature was 0.68m wide and 0.2, deep with a sterile fill of greyish brown silty sand (18306). No continuation of ditch 18305 was seen in Trench 188 to the south, nor of a continuation on the projected line of ditch 18303 in Trench 184, although it is possible that ditch 18303 had turned and was continuing SSE as ditch 18416.
- 4.18.9 Approximately 2m to the north of ditch 18303 a small pit was partly exposed on the west side of the trench. The exposed part of pit 18307 was 0.8m wide and 0.4m deep with steep sides and a rounded base. Filling the pit was brownish grey sandy silt 18308 containing some sherds of Iron Age pottery. This pit and the adjacent ditches were cut through an early colluvial layer, (18301).
- 4.18.10 **Trench 184** was located immediately to the east of Trench 183. Towards the southern end of the trench was irregular pit 18419. Due to the similarities with the underlying geology it was difficult to ascertain the extent of this pit, but it was 0.24m deep, and was filled with a reddish-brown silt clay (18420) that produced some sherds of middle Bronze Age to middle Iron Age pottery. Pit 18419 was also truncated on the north-east edge by ditch 18416, which was 2.15m wide and 0.43m deep with gently sloping sides and a flat base (Fig. 35, Section 18406). It was filled with two naturally silted deposits (18417 overlaid by 18418), the earlier of which produced an assemblage of middle Iron Age pottery, bone and flint. No continuation of ditch 18416 was seen on the projected line in Trench 178 to the north-west.
- 4.18.11 Ditch 18421 cut across ditch 18416 on a NE-SW alignment. It was 0.88m wide and 0.21m deep with a shallow concave profile and a fill of reddish brown silty (18422) that included a small quantity of late Bronze Age or early Iron Age pottery. No continuation of ditch 18421 was seen in Trench 188 to the south-west.
- 4.18.12 At the northern end of the trench was ditch 18412. Truncated during machining, the ditch was evident in both edges of the trench cutting colluvium 18401, and was on an ESE-WNW alignment. It had steep sides and a rounded base, and was filled with two deposits of naturally accumulated silt (18413 and 18414), neither of which produced any finds.
- 4.18.13 **Trench 187** lay south of Trench 182 and south-west of Trench 1833, and revealed a single large pit, only part of which lay within the trench. Pit 18706 appeared to be circular in plan and at least 2.28m in diameter. It had gently sloping sides and was excavated to a depth of 0.38m but could not be bottomed as it continued more than 1m below ground level. The excavated fill comprised greyish brown sandy clay, 18707. No artefacts were recovered from this feature and no charcoal was observed during excavation.

## 4.19 Trenches 151, 180-1, 185-6, 190-1, and 196 (Figs 5, 36 and 37)

- 4.19.1 These trenches were on the east side of Land Parcel 7c, south of Trenches 175 and 176, east of Trenches 179, 184 and 189, and adjacent to Land Parcel 8 (Fig. 5). They occupied a slight plateau on the north-facing side of the valley.
- 4.19.2 **Trench 180** lay east of Trench 179, and below topsoil and subsoil 18001 revealed two ditches and a large pit. Ditch 18006 ran WSW-ENE across the western end of the trench, possibly turning southwards at the west end. It measured 0.54m wide and 0.17m deep with steep sides and a rounded base, and contained a lower fill of dark blueish grey silty clay (18007) overlain by greyish brown sandy clay (18008). Both deposits were devoid of finds. Less than 1m to the south of this was a ditch of similar dimensions and profile on an east-west orientation, turning northwards at the east end (Fig. 37, Section 18001). Ditch 18004 contained single fill of reddish grey, silty clay (18005) that produced a piece of worked flint.
- 4.19.3 The western end of ditch 18004 was truncated by a large pit. Pit 18009 was only partly exposed within the trench, but appeared to be sub-rectangular. It measured 2.61m from east to west and at least 1m north-south, and was 0.72m deep with sloping sides and a flattish base (Fig. 37, Section 18004). It contained a single fill of light-yellow brown, silty sand (18010) which produced a several sherds of early Roman pottery a small residual scrap of prehistoric pottery, some animal bone and fragments of CBM.
- 4.19.4 Ditch 18011 was observed in the section of the trench cutting through deposit 18001. It measured 1.2m wide and 0.22m deep and had steep sides and a flattish base. There was only one fill, a light brown silty sand with occasional charcoal flecks (18012), and there were no finds.
- 4.19.5 **Trench 181** lay east of Trench 180, and revealed a single shallow ditch or gully aligned NNW-SSE whose north end appeared to terminate within the trench. Ditch 18103 measured 0.32m wide and 0.07m deep and had a sterile fill of greyish brown sandy silt. It was initially thought to be a naturally eroded gully due to the slightly irregular shape in plan, but the fill (18104) is very similar to that in features in adjacent trenches, so this feature may be archaeological in origin.
- 4.19.6 **Trench 185** was positioned to the south of Trench 180 and revealed several ditches on various alignments and five discrete features. The discrete features ran roughly north-south along the trench, and were numbered 18503, 18505, 18507, 18509 and 18511 from south to north, spaced between 3.2m and 5m apart. The southernmost and northernmost (18503 and 18511) were only partly within the trench, the other three were small, subcircular pits or postholes 0.45-0.48m across and 0.14-0.24m deep (see 18507, Fig. 37, Section 18502). The exposed part of 18511 was 0.35m across and 0.13m deep, while pit 18503 was 0.7m in diameter and 0.11m deep. All five features were filled with similar deposits of brownish grey, clay silt. Deposit 18508 which filled pit 18507 also contained a few fragments of charcoal and fired clay and produced a scrap of later prehistoric pottery.
- 4.19.7 Ditch 18516 crossed the trench between pits 18507 and 18509 on a NW-SE orientation. It was 1.06m across and 0.27m deep with straight, gently sloping



sides and a rounded base. The ditch fill (18517) was of brownish grey clayey silt, and included some small flecks of fired clay and charcoal. Ditch 18518 was approximately 6m to the north of 18516 and was orientated WNW-ESE. It was 1.5m wide and 0.29m deep with gently sloping sides and a flattish base (Fig. 37, Section 18507), and was predominantly filled with a deposit of greyish brown silty clay (18519) that included charcoal flecks, fired clay fragments, some animal bone and a piece of decorated early Roman pottery. In the top of the ditch was a distinct deposit of dark grey silty clay (18521), which contained more charcoal and some burnt stone. Due to the distinct nature of this deposit, it was recorded as the fill of a possible recut (18520).

- 4.19.8 At the northern end of the trench were two parallel ditches on a NE-SW alignment. Ditch 18513 measured 1.07m wide and 0.42m deep and had steep sides and a rounded base. The lower fill was naturally silted greyish brown silty clay (18514), and was overlain by a light greyish brown silty clay with a thin lens of charcoal at the base (18515). This produced burnt flint, fragments of CBM, worked flint and four sherds of 11th-12th century pottery. Based on the nature of this deposit this would appear to reflect a phase of deliberate backfilling and disuse of the ditch.
- 4.19.9 Ditch 18522 was 0.3m to the north-west of 18513, and terminated at the south-west end within the trench. This ditch was planned but was not excavated; its upper fill was a light grey sandy silt and there were no finds on its surface.
- 4.19.10 No continuations of any of the ditches in this trench were seen on their projected lines in adjacent trenches to the east or south-east, except for ditch 18516, with which supposedly natural feature 15121 to the south-east was in line.
- 4.19.11 **Trench 186** was immediately to the east of Trench 185 and revealed a similar range of features. At the north-east end of the trench were three small pits or postholes very close together: 18607, 18609 and 18611. They were between 0.18m and 0.27m in diameter and up to 0.07m deep with sterile fills of naturally silted material (Fig. 37, Section 18602).
- 4.19.12 Ditch 18605 lay south-west of the pits or postholes, and was on a NW-SE alignment. It was 1.43m wide and 0.35m deep with a stepped profile (Fig. 37, Section 18606) and was filled with a deposit of gravel and large flint nodules (18606), from which several sherds of middle Bronze Age to middle Iron Age pottery were recovered. This was recut by ditch 18613, a steep-sided feature with a rounded base that was 0.69m wide and 0.33m deep. In the base of the ditch was a sterile naturally silted deposit (18614), which was overlain by a dark brownish grey silty sand (18615) whose darker colour was indicative of a more organic origin. Fill 18615 also included charcoal flecks and some scraps of pottery suggesting deliberate dumping.
- 4.19.13 Ditch 18603 further south-west also ran on the same NW-SE alignment but was slighter, being 0.65m wide and 0.2m deep with a concave profile. It was filled with a naturally silted deposit of light greyish brown sandy silt (18604) that was devoid of artefacts. Between ditches 18613 and 18603 was a linear soilmark (18616) on a NNW-SSE alignment that was investigated but was judged to be of natural origin.

- 4.19.14 **Trench 190** was positioned south of Trench 185 and south-west of Trench 186 and revealed two ditches at the north-east end. Ditch 19003 ran SW-NE and measured 0.64m wide and only 0.09m deep. It was filled with a yellowish brown sandy silt deposit (19004) which produced a single piece of worked flint.
- 4.19.15 Ditch 19005 was a very large boundary ditch measuring 2.92m wide and 1m deep. Unusually, it contained a single homogenous fill (19006) comprising yellowish brown, sandy silt. This deposit would have accumulated slowly over a long period of time and included several sherds of pottery and some pieces of worked flint. This appears to have continued in Trench 151 as ditch 15108.
- 4.19.16 **Trench 151** was relocated east of Trench 190 and south of Trench 186, having been moved from its original position for the site compound. At the southern end of the trench was shallow ditch 15115, which was aligned roughly E-W. This measured 1m wide and 0.22m deep with a concave profile, and was filled with orange-brown sandy clay (15116) similar to the surrounding natural geology, but from which early Roman pottery and several pieces of fired clay including some possible oven fragments were recovered. This feature was truncated to the south by a possible pit or ditch terminus 15119 with a greyish brown, sandy clay fill (15120) that contained late Iron Age to early Roman pottery and CBM fragments.
- 4.19.17 North of this was ditch 15113 running NW-SE, which was largely truncated away by similarly orientated ditch 15108 on the north-east side. Ditch 15108 was 2.42m wide and 0.67m deep with steep sides and a flattish base (Fig. 37, Section 15101). Primary fills 15109 and 15110 consisted of brownish grey silty sand and gravelly sand respectively. These were overlain by naturally silted fill brownish grey sandy silt (15111) and a final upper fill (15112) of similar but darker material. A large assemblage of 51 sherds of middle Iron Age pottery was recovered from ditch fill (529g) along with several pieces of fired clay and a charred wheat grain (Sample 196). A few fragments of animal bone were also found in deposit 15111. It is likely that ditch 15108 was the continuation of 19005 on the same line to the north-west.
- 4.19.18 Almost 1.5m to the north of ditch 15108 was a shallow pit that was partly exposed on the west side of the trench. Pit 15106 measured 1.5m wide and 0.2m deep with a slightly concave base (Plate 23). It contained a dark brownish grey sandy clay (15107) with a thin lens of charcoal towards the base, from which Sample 194 produced charred remains of wheat and oat (Sample 194). Fill 15107 also produced pieces of pottery and some fired clay. The pottery was predominately of middle Iron Age but also included some residual sherds of earlier material and a sherd of late Iron Age or early Roman pottery. A narrow soilmark 15121 was seen towards the north end of the trench, and was tested but was believed to be of natural origin, although it is close to the line of ditch 18516 in Trench 185 to the north-west.
- 4.19.19 **Trench 191** was located to the east of Trench 151, and below topsoil and colluvium 19101 revealed two or more ditches. At the northern end of the trench was a large ditch aligned NE-SW. Ditch 19111 measured 2.4m wide and 1.12m deep with sloping sides and a pointed base (Fig. 37, Section 19104; Plate 22). The primary fill (19112), a dark greyish brown silty gravel, produced a small quantity of CBM. This was overlain by a slowly silted

yellowish brown sandy clay (19113) which contained Roman pottery, CBM fragments and some charred wheat (from Sample 195). In the north-east facing section a small recut (19114) was observed truncating deposit 19113. Ditch 19114 was 0.5m wide and 0.32m deep with a rounded profile. It was filled with sterile deposit 19115, the result of natural silting.

- 4.19.20 Feature 19103 lay south of this, and was orientated WSW-ENE. This measured up to 1m wide and 0.18m deep with a shallow concave profile and a sterile fill of greyish brown silty clay (19104). Adjacent to this immediately to the north, and running parallel, was linear feature 19105, which was around 0.5m wide and 0.16m deep. Feature 19105 was judged to be of natural origin, and it was uncertain if feature 19103 was also a shallow hollow in the natural containing natural silting. Nearly 3m further south was ditch 19107, which ran more nearly east-west. Measuring 1.14m wide and 0.36m deep, ditch 19107 also had a single, sterile fill (19108).
- 4.19.21 At the southern end of the trench ditch 19109 was recorded cutting through the colluvial/slopewash deposit 19101. The ditch was 0.98m wide and 0.22m deep with a wide flattish base (Fig. 37, Section 19103). It was filled with a greyish brown silty sand (19110) that included a small scrap of Roman pottery. This feature may be a continuation of ditch 15115 to the west, whose dimensions were very similar, and which also contained Roman finds.
- 4.19.22 **Trench 196** was positioned to the south of Trench 191 and revealed several intercutting ditches at its eastern end, all cut into colluvial layer 19611. Ditch 19612 was aligned NNE-SSW and entered the trench from the south, but was truncated by ditch 19615 to the north. Ditch 19612 was 1.18m wide and 0.22m deep with a broad concave profile, and was filled with greyish brown sandy silt 19613. An early Neolithic leaf-shaped arrowhead and a small end-and-side scraper were the only finds from this feature.
- 4.19.23 Feature 19608 was a small ditch or gully west of 19608, running in from the south on an ENE-WSW alignment, and was also truncated by ditch 19615 at the north-east end. It had a shallow concave profile and a naturally silted fill (19609), from which a very little later prehistoric pottery was recovered.
- 4.19.24 Ditch 19615 was a slightly sinuous ditch aligned E-W, measuring 0.97m wide and 0.5m deep. It had a primary fill (19616) overlain by a naturally silted upper fill (19617), neither of which contained finds. The same ditch was excavated and recorded further to the west as ditch 19602. In this location it contained just a single fill (19603) which produced both late Bronze Age to middle Iron Age pottery and worked flint. The ditch was truncated on its northern edge by curvilinear ditch 19604. This measured 0.9m wide and up to 0.46m deep with a concave profile, and was filled with greyish brown sandy silt 19605 that produced middle Bronze Age to middle Iron Age pottery, animal bone and a large fragment of fired clay that appears to have been part of a perforated plate from an oven or pottery kiln. On its north side ditch 19604 also truncated another ditch. Ditch 19606 was aligned roughly east-west, and measured 0.62m wide and 0.4m deep. It had a single fill of greyish brown sandy silt (19607) which contained several sherds of Roman pottery and some pieces of worked flint.

## 4.20 Trenches 194, 197-8 and 202 (Figs 5, 38 and 41)

- 4.20.1 This group of trenches were located south-west of Trench 190 near the centre of Land Parcel 7c on a relatively level area of the site, above the north-facing slope of the east-west valley to the north (Fig. 5).
- 4.20.2 **Trench 194** was situated at the north-east edge of this group, and contained two narrow ditches or gullies cut into colluvium 19401. Ditch 19403 was orientated NNE-SSW, and measured 0.39m wide and 0.37m deep with a steep-sided concave profile and a sandy silt fill (19404). At the south-west end of the trench, ditch 19405 was recorded in both sides of the trench, and was on a NW-SE alignment. It was 0.5m wide and 0.3m deep, had steep sides and a flattish base and was filled with a sandy clay deposit (19406). Neither feature produced any finds.
- 4.20.3 **Trench 198** was south-west of Trench 194 and was laid out on the same NE-SW orientation. It contained two ditches and a large irregular pit. Ditch 19806 was exposed at the very south-west end of the trench, and ran in from the west on an ENE-WSW alignment, terminating within the trench. It contained a naturally silted deposit of silty clay and was devoid of any finds.
- 4.20.4 North of this ditch 19805 crossed the trench on a broadly E-W alignment. This ditch was 0.9m wide and 0.34m deep, and matches a field boundary marked on the 1st edition OS map. It appears to have continued in Trench 197 to the west, where it was recorded as ditch 19702. No finds were recovered from 19806, the single fill of ditch 19805, nor from the slot cut into 19702.
- 4.20.5 Ditch 19805 truncated a large irregular pit on its north side. Pit 19804 measured 3.7m in length and at least 1.38m wide, extending beyond the edge of the trench. The steep-sided irregular cut was 0.74m deep and filled with mixed sandy silt deposits 19808, 19809 and 19812 (Fig. 41, Section 19801). No dating evidence was recovered from the feature but it may perhaps have been either an extraction pit or a particularly large tree-throw hole that was deliberately backfilled.
- 4.20.6 **Trench 197** lay west of Trench 198, and revealed a broadly east-west ditch and a posthole. Ditch 19702 was 1.55m wide and 0.56m deep with a bowl-shaped profile (Fig. 41, Section 19700), and was probably a continuation of ditch 19805, although the line of its projected continuation was offset to the south of 19805 by more than 1m. Further north along the trench a small posthole was identified. Posthole 19704 was 0.3m in diameter and 0.09m deep with a rounded base. It was filled with deposit 19705, a greyish brown clayey silt with occasional charcoal flecks but no finds. No other postholes were recorded in the vicinity.
- 4.20.7 **Trench 202** lay south of Trenches 197 and 198, and contained a small pit and a tree-throw hole. Pit 20204 was not fully revealed within the trench, but the exposed part was 0.38m across and 0.34m deep, and was filled with a mixed deposit (20203) indicating a deliberate phase of backfilling, but did not contain any artefacts.

## 4.21 Trenches 159, 161, 207-8 and 213 (Figs 5, 39 and 41)

- 4.21.1 This group of trenches was located west, south-west and south of Trenches 197, 198 and 202 on the west edge of Land Parcel 7c, and close to the south

end of the land parcel (Fig. 5). They revealed a sparse distribution of ditches, pits and possible postholes.

- 4.21.2 **Trench 159** lay on the west edge of the group, and was orientated NW-SE. It revealed an irregularly shaped pit. Pit 15903 had steep sides and measured a depth of 0.46m. Within the pit was a dark grey brown sandy silt that produced worked flint.
- 4.21.3 **Trench 161** lay south-east of Trench 159, and was on the same orientation. It revealed a pair of pits, 16103 and 16105 (Fig. 41, Section 16100) . Pit 16105 was a small circular pit only 0.21m across and 0.06m deep with a sterile fill of dark grey brown sandy silt. It was truncated to the north by 16103, a large ovoid pit 1.26m in length. It was just 0.07m deep and contained a fill of light brownish grey sandy silt (16104) with charcoal and burnt flint that was sampled ((Sample 193). The fill produced an assemblage of finds including several small sherds of middle Bronze Age pottery and three worked flints, including a discoidal core of later Neolithic date.
- 4.21.4 In **Trench 207**, which lay east of Trench 159, a possible posthole was recorded in the west section of the trench close to its south end. Posthole 20703 was 0.48m across and 0.4m deep with very steep sides, stepped on the north side, and a pointed base (Fig. 41, Section 20701). The sole fill (20704) was a sterile deposit of silty sand.
- 4.21.5 **Trench 208** was positioned east of Trench 207, and revealed a small undated ditch aligned NE-SW. Ditch 20803 was 0.37m wide and 0.26m deep with a single fill of naturally silted material. No continuation of this ditch was seen on its projected line in Trench 212 to the south-west.
- 4.21.6 **Trench 213** lay south of Trench 208 and revealed a large E-W aligned ditch at its south end. Ditch 21303 measured 1.18m wide and 0.16m deep with a wide flat base (Fig. 41, Section 21300). It was filled by deposit 21304, an orangey grey sandy clay that contained a small quantity of worked flint and a sherd of medieval (c 1270-1350) pottery. Given the alignment of this ditch, it is surprising that it was not observed in Trench 212 to the west, or 214 to the east.

## 4.22 Trenches 216, 223 and 226 (Figs 5, 40 and 41)

- 4.22.1 These trenches were located east and south-east of Trench 213 at the south end of Land Parcel 7c, close to the Muckingford Road (Fig. 5).
- 4.22.2 **Trench 223** lay south of Trench 213 and revealed a ditch aligned NNW-SSE at its south end. The ditch (22303) measured 0.68m wide and 0.32m deep and had steep sides and a sloping base (Fig. 41, Section 22300). It contained a naturally silted fill of orangey brown silty sand that was without finds.
- 4.22.3 **Trench 226** was positioned in the south-east corner of the field and contained a small pit. Pit 22603 was 0.84m in diameter and 0.19m deep with steep sides leaving to a flat base. The fill (22604) comprised mid greyish brown, sandy clay and also included a fragment of CBM.
- 4.22.4 **Trench 216** was approximately 65m to the north of Trench 226. It revealed the terminus of a ditch aligned NW-SE. Ditch 21603 was 1.35m wide and 0.62m deep and contained a gravelly primary fill (21603) overlain by a

secondary fill (21605) of sandy clay silt (Fig. 41, Section 21600). This feature was devoid of finds.

## 4.23 Trenches 229-30 and 233-5 (Figs 5, 42 and 43)

- 4.23.1 Trenches 229, 230, 233, 234 and 235 were positioned at the northern end of Land Parcel 8 (Fig. 5). This section of the site was on the north facing side of the valley and sloped gently downwards to the north.
- 4.23.2 **Trenches 229 and 230** exposed a group of ditches. Two of these (ditches 22903 and 23010) were at right angles, ditch 22903 being aligned WSW-ENE and ditch 23010 NNW-SSE. Although 22903 was broad and 23010 narrow, they were both shallow with concave profiles and contained lines of animal long bones placed along their bases (Fig. 43, Section 22900; Plate 24). The bones were given context numbers 22905 and 23011 respectively. The ditches were then each filled with a deposit of greyish brown, silty clay (respectively 22904 and 23012), but it is unclear if this was a deliberately backfill or something that accumulated naturally. A fragment of post-medieval brick was recovered from the surface of deposit 22904.
- 4.23.3 At the eastern end of Trench 230 were two further ditches, also on ENE-WSW alignments. Ditch 23005 was 0.43m wide and 0.11m deep and had steep sides and a flat base. It contained a sterile yellowish brown sandy silt deposit (23006). Ditch 23005 appears to have been recut on the south-west side by ditch 23008. This larger ditch had a similar profile but measured 0.62m wide and 0.14m deep (Fig. 43, Section 23002). Its fill (23009) was a dark brown sandy silt that produced a small amount of animal bone and nine worked flints, including four blades.
- 4.23.4 **Trench 234** lay south of Trench 229, and revealed a cluster of small pits at the north-west end of the trench. Pits 23414, 23419 and 23412 were all circular in plan with near-vertical sides and flat bases. Pit 23421 was only 0.06m deep and was cut by pit 23412 (Fig. 43, Section 23402), while 23412 was 0.20m deep, but 23419 and 23414 were both approximately 0.4m deep (Fig. 43, Section 23404; Plate 25). All of pits 21312, 21319 and 21321 were filled with a similar deposit of mid grey silty clay. Pit 23414 had three fills, and a large sherd of middle Bronze Age to middle Iron Age pottery was recovered from 23415, the primary fill of the pit.
- 4.23.5 Immediately to the south was a narrow ditch aligned ENE-WSW and with a line of bones visible in its fill. Ditch 23417 was left unexcavated but was clearly of the same type and function as those recorded in Trenches 229 and 230.
- 4.23.6 In the south-east end of the trench was a large natural depression, which was numbered 23408. It measured 6.95m wide (N-S) and up to 0.35m deep with a slightly concave base, and was filled with a sequence of naturally silted deposits: 23409, 23410 and 23411 (Fig. 43, Section 23400). Whilst 23409 was a light grey silty clay, the final upper fill 23411 was a dark grey silty clay with orange mottling and frequent small stones. Deposit 23410 formed an interface between these two and contained a small amount of middle Bronze Age to middle Iron Age pottery and flint.
- 4.23.7 **Trench 235** lay immediately to the east of Trench 234 and again exposed a large silty clay depression, here numbered 23506, which was clearly a

continuation of 23408. Although not fully excavated, one of the earlier fills, 23507 still produced a sherd of Roman pottery, animal bone and pieces of fired clay including oven fragments. Although sampled (Sample 75) it did not produce any charred remains. In both trenches the feature appears to have been left to silt up naturally and was probably frequently wet. It is however unclear how the depression was created in the first place as it appears to be entirely natural, but the alignment, which was not running downslope, means that it is unlikely to have eroded naturally.

- 4.23.8 Some way south of the large depression was a ditch, also on an E-W alignment. Ditch 23503 measured 1.65m wide and 0.55m deep and had steep straight sides and a flat base (Fig. 43, Section 23500). It was predominantly filled with deposit 23504, a grey, clayey silt that included both pottery and flint. The pottery comprised a sherd of possible Beaker and a second, less diagnostic, prehistoric sherd. This was overlain by a thin deposit of yellowish grey silt (23505).
- 4.23.9 **Trench 233**, situated north of Trench 235, revealed two features that were probably the remains of tree-throw holes. Feature 23302 produced five pieces of worked flint in varying condition, while feature 23306 was devoid of finds.

## 4.24 Trenches 237-243 (Figs 5, 44 and 45)

- 4.24.1 This group of trenches were positioned in the southern end of Land Parcel 8 (Fig. 5). Although a large rectilinear cropmark had been identified immediately to the east of these trenches, outside of the site boundary, only a few discrete cropmarks had been recorded within the site, all of them within areas containing services, and so excluded from evaluation (WSI Q, fig. 8).
- 4.24.2 **Trenches 237 and 238** lay south and south-west of Trench 235 respectively, and revealed a large E-W aligned ditch. In Trench 237 this was excavated and recorded as ditch 23703. In this trench the ditch was partially revealed running along the western two-thirds of the trench, at which point it appeared to turn northwards. The full width of the ditch was not exposed within the trench except where it turned, where it was about 2m wide. Where excavated further west it measured at least 1.34m wide and 0.55m deep with a sloping slightly concave north edge (Fig. 45, Section 23700). It was filled with a relatively homogenous deposit of brown sandy silt (23704) that produced an assemblage of middle Iron Age pottery, animal bone, struck flint and fragments of structural fired clay. A sample was also recovered from deposit 23704, but no charred remains were identified. This ditch continued westwards across Trench 238 as ditch 23811, whose full width was 2.2m, but was not excavated.
- 4.24.3 Truncating ditch 23811 was the end of NW-SE aligned ditch 23806 (Plate 26), which measured 0.88m wide and 0.27m deep with sloping sides and a rounded base (Fig. 45, Section 23801). Its dark grey brown, silty clay fill (23807) included a reasonable assemblage of early Roman pottery (AD43-70) and a fragment of a possible Langton Down style brooch, a type dated AD25-60. The ditch either ended or turned eastwards after 7.3m, but appeared to continue southwards as ditch 23808 after a gap of only 1.4m. This ditch was not excavated, but several large sherds of early Roman pottery (AD43-120) were also recovered from its surface. Ditch 23808 continued SSE beyond the

end of the trench, and was probably the same as ditch 23905 in Trench 239 to the south, which was on a very similar alignment and line.

- 4.24.4 A further ditch crossed the trench less than 0.5m to the north of east-west ditch 23811 on a broadly parallel alignment. Ditch 23809 measured 0.66m wide and 0.21m deep with a rounded profile, and had one naturally accumulated fill (23810) that did not produce any finds.
- 4.24.5 **Trench 239** lay south of Trench 238, and revealed a ditch running SSE at the northern end and a pit or ditch terminus at the south end. Ditch 23905 appeared to be the continuation of 23808 to the north, which contained Roman pottery, and so ditch 23905 was not further investigated.
- 4.24.6 Large pit or ditch terminus 23904 was only partly revealed within the southern end of the trench, but measured at least 1.35m wide and 0.5m deep and had steep straight sides and a flattish base. It was filled with a deposit of greyish brown, silty clay (23904) which produced a small amount of Iron Age pottery and worked flint. Some charred wheat also came from environmental Sample 39.
- 4.24.7 **Trenches 242 and 240** were located to the south and east of Trench 239. At the western end of Trench 242 were several ditches aligned NE-SW. The westernmost, ditch 24210, was only partly revealed within the trench, and was not excavated. Less than 1m south-east of this were ditches 24205, 24207 and 24203, the middle of which (24207, terminated at its NE end within the trench. The relationship between ditch 24207 and 24203 was not established, as the edges of these ditches only just met. These ditches were of varying size, ditch 24203 being just 0.59m wide and 0.07m deep, ditch 24207 1.05m wide and only 0.2m deep, while ditch 24205 was 2.6m wide and at least 0.27m deep with steep sides, but was not bottomed (Fig. 45, Section 24201). All of these ditches were filled with naturally silted greyish brown, silty sand, and a reasonable assemblage (331g) of early Roman pottery was recovered from 24206, the fill of ditch 24205.
- 4.24.8 A N-S ditch (24209) was partly exposed at the eastern end of Trench 242, but was not further investigated.
- 4.24.9 The southern end of Trench 240 contained a broad soilmark on the same NE-SW alignment as the ditches in Trench 242, and on much the same line, suggesting that the separate ditches had all merged here. Investigation confirmed the presence of several ditches on broadly NE-SW alignments: 24003, 24005 and 24007 (Fig. 45, Section 24000). These three ditches were respectively 0.16m, 0.32m and 0.38m deep, and appeared to be recut successively on the south-east side, although several sherds of early Roman pottery came from deposit 24006, the fill of 25005, whereas 24007, the light brown sandy silt fill of ditch 24008, produced Iron Age pottery and some worked flints.
- 4.24.10 At least two of these ditches appear to continue into **Trench 243**, where ditches 24303 and 24305 were revealed on a NE-SW alignment at the northern end of the trench. Ditch 24303 was 1.2m wide and 0.3m deep with sloping sides and base tapering to a point (Fig. 45, Section 24300), and had a single fill of greyish brown silty clay (24304) which produced both pottery (now lost) and some pieces of worked flint. The adjacent ditch, 24305 was



only 0.34m wide and 0.09m deep, and was filled with 243006, a similar but sterile deposit of silty clay.

- 4.24.11 **Trench 241** was located to the east of Trench 243 and revealed a small NW-SE aligned ditch on a broadly perpendicular orientation to ditches 24203 and 24205. Ditch 24103 was 0.6m wide and 0.11m deep with steep shallow sides and a broad flattish base. It contained a deposit of greyish brown, sandy silt (24104) which produced a small amount of Saxo-Norman pottery and some worked flint.

## 4.25 Finds summary

- 4.25.1 **Prehistoric pottery.** The evaluation produced 393 sherds of prehistoric pottery weighing 2606g from across 39 trenches. Due to the predominance of small body sherds much of the assemblage could only be dated to the middle Bronze-Age to middle Iron Age based on fabric, although diagnostic late Bronze Age, early Iron Age and middle Iron Age material was also found. Six contexts produced possible early Neolithic material and a probable Beaker sherd was also found.
- 4.25.2 **Late Iron Age and Roman pottery.** An assemblage of some 246 sherds of late Iron Age and Roman pottery was recovered from the evaluation. The material was predominantly dated to the early Roman period and no definitely later groups were identified. With the exception of two imported vessels and one sherd from the Verulamium industry, the pottery is likely to have been manufactured locally within the south Essex/Thameside region.
- 4.25.3 Although the pottery was recovered from across the site, there was a distinct concentration of features in Land Parcel 8 that contained pottery of these periods, and it is from these that the majority of the assemblage came. This is also where the sherd size and general condition of the pottery was best preserved, suggesting that it had not travelled far from its primary point of deposition.
- 4.25.4 **Medieval and post-medieval pottery.** A total of 123 sherds of medieval and post-medieval pottery weighing 1447g were recovered from 31 contexts. A range of pottery from perhaps the early/mid Anglo-Saxon period through to the 19th century was identified. Most of it however is medieval and comprises ordinary domestic wares.
- 4.25.5 **Fired clay.** A large quantity of fired clay amounting to 270 fragments weighing 4553g was recovered from across the site. Only one fragment can be dated as Roman, and that is the perforated plate from context 19605. Three fragments of possible triangular brick were also recorded from context 9607 and these can be dated to the Iron Age or early Roman periods.
- 4.25.6 **Ceramic building materials.** A total of 23 fragments of CBM weighing 4232g was recovered from the evaluation. The assemblage contains one whole brick and several large fragments of brick of 19th century date and has a high mean fragment weight of 200g as a result. The assemblage includes two pieces of Roman date, but otherwise consists overwhelmingly of late medieval/post-medieval material.
- 4.25.7 **Briquetage.** Briquetage from salt production was found in three fills of a single pit (4903) in Trench 49, and a scrap in the overlying colluvium. Some 70

pieces were found, weighing 339g, but as this comes from only one half of the pit, which was not bottomed, the assemblage in the pit is probably substantially larger. They were found alongside reasonable quantities of late Bronze Age pottery, and a late Bronze Age date for the briquetage is therefore assumed.

- 4.25.8 **Clay pipe.** Only six sherds were recovered, but include an early stem fragment of late 17th century date, a bowl of late 18th or early 19th century date and another of mid-19th century date.
- 4.25.9 **Metals and Glass.** A total of 14 metal objects (19 fragments) were recovered from 7 contexts across 5 trenches. Most of the metalwork comprises iron objects including nails, a knife blade and a key, but also includes two copper alloy objects and two fragments of lead alloy. One of the copper alloy objects is a 1st century AD Roman brooch, the other a lace tag or chape of post-medieval date, and the iron objects are probably all of post-medieval or modern date. A single piece of post-medieval wine bottle glass was recovered from Trench 101.
- 4.25.10 **Worked Stone.** A single piece of roughly squared tufa was recovered from a medieval pit in Trench 94.
- 4.25.11 **Flint.** A substantial assemblage of 1321 worked flints was recovered during the fieldwork. The largest and most significant component of the worked flint assemblage comes from a series of *in situ* or minimally disturbed Mesolithic flint scatters located within a number of trenches on the valley floor in Land Parcel 7a, but there was also evidence for widespread prehistoric activity from residual flintwork recovered from cut features and material from topsoil, subsoil and colluvial deposits across the evaluated area. The residual material includes a proportion of Neolithic and early Bronze Age material, but the assemblage does not appear to include any coherent assemblages of later prehistoric date from individual features or deposits.

## 4.26 Environmental summary

- 4.26.1 **Charred plant remains and charcoal.** Most of the flots were of poor quality, but there were some exceptions, although most of the richer charcoal samples were not dated, including a pit with a rich deposit of pure lime charcoal in Trench 102. Some of these were associated with burnt flint or fired clay, suggesting industrial activity of some sort. Two later Iron Age pits in Trenches 151 and 178 did however contain charred plant remains that included cereals, and wheat, legumes and bedstraw were found in medieval pits in Trench 94.
- 4.26.2 **Waterlogged plant and insect remains.** Samples were generally of very poor quality, though rush seeds were found in samples from Trench 25 and sedge seeds from Trench 97, and there were also rare insect remains in these peaty samples. Sample 174 from a ditch in Trench 170 contained water flea, a useful indicator of permanent waterlogging. Molluscan remains were rare and very small.
- 4.26.3 **Animal bone.** A total of 441 animal bone fragments, weighing 4.731kg, was recovered by hand excavation from 29 contexts. Only 9.2% of the assemblage was identifiable, and this was dominated by Equid bones from just three features in adjacent trenches, all ditches containing bones along the base. One of these ditches contained a post-medieval CBM fragment, and the

preservation of the bones in these features may be due to their relatively recent date.

- 4.26.4 **Human remains.** The remains of one adult individual were revealed as a crouched inhumation burial in a sub-oval pit. The individual was crouched, lying on the right side with the head to the south. The individual was less than 25% complete and highly fragmented, and the sex of the individual could not be determined. The elements comprised mandibular and maxillary dentition (including 17 teeth), fragments of the humerii, right radius and ulna shaft, right hand, fragmented right femur shaft, tibia and fibula shaft.
- 4.26.5 **Marine Shell.** Oyster shells were recovered from medieval features in Trench 101.

## 5 Discussion

---

### 5.1 Reliability of field investigation

- 5.1.1 The layout of trenches provided a good overall coverage of the site. However, it was necessary to omit 19 trenches from the scope of works due to various constraints on site, reducing the available area for investigation. Whilst it was possible to reposition some trenches and maintain a coverage in excess of 4% in the accessible areas, there remains a reasonably large section of Land Parcel 7b that could not be accessed. Due to the large lake and protected margins of surrounding habitat, almost half of Land Parcel 7b was inaccessible during this phase of evaluation. Whilst no trenches were planned for the area occupied by the lake, satellite imagery shows that this only developed since 2010 and the potential for significant archaeological remains around the edges of the lake remains unknown.
- 5.1.2 There were significant variations in geology across the different land parcels and the varied topography also meant that archaeological horizons were present at different depths. Inevitably this created a challenging situation for the identification of archaeological features. Most features were recognisable during the initial machine excavation of the trenches, particularly in the south of the site where they were cut into gravelly head deposits and the Taplow Gravels. Other features were identified during subsequent revisits to trenches after long periods of weathering, and the detailed recording of sediments carried out by the geoarchaeologists on site meant that some trenches were revisited several times, providing further opportunities to identify features not previously visible. Consequently, the reliable identification of features was only really hampered by the ground conditions towards the base of the valley where the ingress of groundwater was a particular challenge. Not only did it reduce visibility, but some trenches were rendered unsafe to enter following the collapsing of the sides and so detailed cleaning and hand excavation was not possible. This issue was, however, limited to small handful of trenches, and overall there was a positive correlation between waterlogged trenches and low densities of archaeological activity, so the impact of this should not be overstated. The main impact of this is likely to be on the identification of *in situ* flint scatters, as these require both favourable weathering of deposits and an opportunity to examine deposits in detail.
- 5.1.3 Relatively few cropmark features were present within this site, and the correspondence between these and below-ground archaeological features was variable. In Land Parcel 6, the cropmarks targeted by Trenches 9 and 10 produced no corresponding features, while in contrast, the cropmark enclosure in Land Parcel 7a targeted by Trenches 61, 68 and 75-78 and 86 did mostly reveal corresponding ditches, although Trenches 77 and 86 on the south-east were blank. This is probably due to truncation by later agriculture and erosion, as the surviving ditches in adjacent trenches were much slighter than those further north and west. Only parts of the narrow rectilinear enclosure to the south of this targeted by Trenches 93 and 94 proved to correspond to archaeological features, and there were no cropmarks corresponding to the large pits found to its east. The reason here may be the

varying character of the underlying deposits and the depth of overlying colluvium.

- 5.1.4 A significant number of ditches and discrete archaeological features were revealed, most notably in Land Parcels 7c and 8, that did not show up as cropmarks. The explanation for this lack of reliability is both topographical and geological. Due to the valley that runs through the centre of this site, the only place where the soils are sufficiently shallow to produce reliable cropmarks is on the more elevated portions of the site. Whilst the archaeological horizon across the majority of Land Parcels 7c and 8 was quite shallow, the features found here did not generate cropmarks because there was insufficient contrast between their fills and the underlying head deposits or the shallow colluvium through which they were cut, and with which they silted up.
- 5.1.5 The identification of significant archaeological remains not previously known about attests to the value of the investigation, but while the association of ditched enclosures or field systems with discrete features such as pits and postholes is unsurprising, there was also a significant amount of activity whose focus and form was less clear, consisting either of scattered pits, small groups of postholes and a burial or of surface flint scatters. Further evidence of derived activity was also evident as residual artefacts in colluvial layers and in ploughsoils. Sites of types represented by remains like these are intrinsically difficult to identify through evaluation and even harder to define in terms of extent, character, function and significance.

## 5.2 Interpretation

- 5.2.1 **Late Upper Palaeolithic.** Activity during this period is demonstrated by two long blades, one from Trench 107 and another from Trench 139. In the case of Trench 107, the remainder of the flint assemblage was also notable for the presence of several unusually large blades that could be also indicative of flint working from this period. The survival of late Upper Palaeolithic *in situ* flint scatters is very rare, but radiocarbon dating of a possible buried soil in Trench 91 to either the LUP or early Mesolithic period, while not associated with artefacts, suggests that preserved horizons of this period may survive within the valley bottom on the site. Given the nature of the topography, there is good potential for further remains of this date to be present within the site boundary.
- 5.2.2 **Mesolithic.** Mesolithic activity on the site was evident from a substantial assemblage of flint, the vast majority of which was recovered from Trenches 97, 98, 99, 103, 104, 105, 107 and 109. The flint horizons are not deeply buried, and the presence of later pottery or other finds on some of their surfaces shows that later material has been worm-sorted down to these horizons. It is possible that some of the gaps or areas of lower density in the flint horizons may be due to truncation, although the overwhelmingly fresh character of the material argues that the assemblages from these trenches are either *in situ* or are little disturbed. No attempt at refitting has been made on the small percentage of the material that was recovered at this stage, although two flakes from the same core were noted among the small assemblage from Trench 113.
- 5.2.3 Even within the trenches and the surviving horizons, there appear to have been areas of greater concentration, probably indicating that the large area

covered by the flint horizons consists of a number of separate episodes of flintworking, some probably overlapping in space. Based on the limited number of microliths from the sampled assemblage the activity has been dated to the later Mesolithic period, although the presence of larger flint blades (and two microliths from tree-throw holes or natural hollows elsewhere on the site) suggests an early and a middle Mesolithic component as well. Fragments of burnt flint were present throughout the assemblage, suggesting that hearths or bonfires were also associated with the scatters. Insufficient of the concentrations of flint were recovered to determine whether the scatters represent long phases of occupation, but the extent of the scatters across both sides of the valley would suggest that the site was repeatedly visited.

- 5.2.4 Whilst there was evidently a focus of activity in Land Parcel 7a, contemporary flintwork was found more widely across the site. Trench 113 to the east of the main focus in Land Parcel 7b produced a small scatter of flints of similar character on a buried land surface, and at the north-western end of Land Parcel 7c natural features (including tree-throw holes) 13810, 13911 and 14109 all produced flint in sufficient quantities to suggest that activity had continued into this area. Trenches 176 and 230 at the north ends of Land Parcels 7c and 8 respectively also yielded flints consistent with a Mesolithic date. Some of the few diagnostic pieces from tree-throw holes or other natural deposits suggest a middle or even an early Mesolithic date, indicating that the Mesolithic presence in the east-west valley crossing the site may indicate visits spanning much or all of the period.
- 5.2.5 There is a clear focus of later Mesolithic activity of regional significance that has been preserved along the base of the valley in Land Parcel 7a, and Mesolithic activity of various phases appears to have extended further down the valley bottom across the adjacent parts of Land Parcels 7b, 7c and 8.
- 5.2.6 **Early Neolithic.** A small handful of features and deposits bearing either diagnostic flintwork or pottery of possible early Neolithic date were identified across the site. Some of this material occurred residually alongside later finds, and due to the lack of diagnostic sherds much of the pottery tentatively dated as early Neolithic may also be attributable to a later date.
- 5.2.7 Pits 6703 and 14107 contained possibly early Neolithic pottery, although the latter also contained a circular scraper more usually given a late Neolithic/early Bronze Age date. Ditch 19612 produced a fine leaf-shaped arrowhead and a side scraper, but there were no other finds, and these could be residual in a later feature. Similarly, the Neolithic microdenticulate blade in ditch 17516 was the only find from this feature, and may also have been residual in such a large feature. While no features of definitely early Neolithic date have been identified, features of this period other than ceremonial monuments tend to be small pits, often occurring as isolated examples or in small numbers, which are often missed by trial trenching. The pattern of early Neolithic activity at the neighbouring site of Mucking was of similarly scattered features and finds (Evans *et al.* 2016, 66-70).
- 5.2.8 The other major characteristic of early Neolithic activity is surface scatters, as for instance found at the Eton Rowing Course (Allen *et al.* 2013). While there is no evidence of middens, flintwork of the early Neolithic shares many of the characteristics of later Mesolithic flintwork, and given the limited sample of the

scatters that was recovered, it is also possible that some part of the area of scatters is of early Neolithic rather than Mesolithic date.

- 5.2.9 The evaluation has demonstrated the presence of early Neolithic material on the site, and the potential for features and other settlement evidence in the vicinity of the excavated trenches.
- 5.2.10 **Late Neolithic and early Bronze Age.** Diagnostic finds of these period were very few, and no features can certainly be attributed to either period. Only a single Beaker sherd of early Bronze Age date was recovered, and this came from a ditch in Trench 235 that also contained another sherd believed to be later. Diagnostic flints of the late Neolithic/early Bronze Age included an end scraper from Trench 98, two hard-hammer small scrapers from topsoil in Trenches 138 and 139 and a Levallois core from a pit in Trench 161. There was a wider scatter of hard-hammer struck flakes that could be of the late Neolithic/early Bronze Age, but were more likely of later Bronze Age date.
- 5.2.11 A number of pits containing only small numbers of undiagnostic flint flakes were identified in Land Parcel 6, and without diagnostic tools or scientific dating it is impossible to say if some of these were of these periods. Radiocarbon dating of features without contemporary artefactual dating in the LTC evaluations to the west and south of the site has, however, revealed both pits and ditches of these periods (OCA 2020a, 34; OCA 2021a, 40).
- 5.2.12 Burnt flint and charcoal was recovered in quantity from a hollow upon a buried soil (4004) in Trench 40. Recent radiocarbon dating has demonstrated that such spreads may be of late Neolithic or early Bronze Age date, as for example at the Eton Rowing Course (Allen *et al.* 2013, 398 and 451-454), but could equally be of later date.
- 5.2.13 No evidence of any monuments of these periods has been indicated by the evaluation. Even more so than in the early-middle Neolithic, however, the character of domestic features of the late Neolithic and early Bronze Age is of scattered (and often single) pits, which are only fortuitously found in evaluation. The finds from the site demonstrate a human presence in these periods, and contemporary features may well survive between the excavated trenches.
- 5.2.14 **Later Bronze Age and Iron Age.** No diagnostic middle Bronze Age features, or indeed pottery or flint was identified from the site. There are, however, virtually no flint tool types diagnostic of the middle Bronze Age, and some of the pottery attributed to a broader middle Bronze Age to middle Iron Age date may belong to this period.
- 5.2.15 An undated extensive spread of burnt flint and charcoal on a buried land surface in Trench 40 has been mentioned above, and equally large assemblages of burnt flint were recovered from a ditch in Trench 104 and a pit in Trench 138, the last cutting a pit that contained later prehistoric pottery. All of these lie on the lower slopes or in the base of the east-west valley, classic locations for burnt mounds. Burnt mounds are characteristic of the later Bronze Age (though can be earlier), and any or all of these could date to the middle or late Bronze Age. That in Trench 40 could potentially be associated with the cropmark enclosure 150m to the west in Land Parcel 5, and dated by evaluation to the middle Bronze Age (Fig. 2; OCA 2020a, 34).

- 5.2.16 The clearest evidence for late Bronze Age activity was a large assemblage of pottery discovered in pit 4903, which was accompanied by 69 fragments of briquetage, mainly from vessels but also including one pedestal. As this represents less than half of the pit fills (as only one half was dug, and this was not bottomed), there was clearly a substantial assemblage in this pit. The briquetage demonstrates that the site was involved in the production or distribution of salt, and the presence of at least one pedestal does suggest that salt production, rather than simply transportation or consumption, was carried out on site, despite it being several km from the current shoreline. A pit partly revealed in Trench 42 to the north, which contained much brunt clay and charcoal, may (although undated) have been associated with this, as may the burning in Trench 40 north of that. A similar mixture of late Bronze Age vessels and pedestals was found at Mucking (Brudenell 2016a), and in North Kent in pits at Cobham Golf Course, which Champion argued were involved in secondary drying, crystallisation and moulding of the salt (Champion in Booth *et al.* 2011, 216-8).
- 5.2.17 A single residual sherd of late Bronze Age pottery was recovered from ditch 4809 and a decent assemblage of late Bronze Age or possibly early Iron Age pottery was recovered from pit 1704. Groups of late Bronze Age or early Iron Age sherds, but thought more likely to be late Bronze Age, also came from a colluvial layer in Trench 4, from a pit in Trench 109, from a layer in Trench 149, and (less certainly) from a ditch in Trench 184.
- 5.2.18 These features and finds indicate that late Bronze Age activity, even if limited, appears to have been focussed primarily on the west side of the site along the lower contours of the valley slope, primarily in Land Parcel 6 but also extending eastwards into Land Parcel 7a and southwards into Land Parcel 7c. It is possible that this pattern is partly the result of preservation factors, as more truncation and erosion is generally evident on higher ground. Either way, this pattern of dispersed activity mirrors the evidence from the opposite (northern) side of the valley in Land Parcel 5, where later Bronze Age or early Iron Age pottery was also found in scattered features and colluvial deposits (OCA 2020a).
- 5.2.19 Whether the pottery in Trenches 184 and 196 was late Bronze Age or early Iron Age, this area was certainly a focus for Iron Age activity, as there was pottery of early or middle Iron Age date from a concentration of pits, postholes and ditches spread across Trenches 151, 175, 178, 183, 184 and 237. Despite the generally poor preservation of environmental remains, the majority of charred grains and in particular, wheat was recovered from these features. It would appear that, from the early Iron Age onwards, and possibly starting earlier, the northern part of Land Parcel 7c became the focus of a settlement, though whether this was open or enclosed is unclear, as despite a predominantly NW-SE or NE-SW orientation, ditches could not generally be traced between trenches. This may reflect an interrupted ditch system, examples of which are more common in the later Bronze Age, or may indicate that the ditches belonged to small enclosed areas within an open settlement layout. Whilst these trenches form the nucleus of the activity, the surrounding trenches (176, 180, 185, 196, 234, 235, 239 and 240) also yielded material that could be middle Iron Age in date, perhaps indicating an expansion of the settled area over time into Land Parcel 8. Some features in this area contained



fabrics common in the late Iron Age-early Roman periods, but mostly in association with Roman pottery, so whether a distinct late Iron Age phase of activity existed is unclear.

- 5.2.20 An outlier to this concentration was a single pit in Trench 96 (in the valley bottom in Land Parcel 7a), which contained fragments of a triangular oven brick or loomweight, a type characteristic of the Iron Age period, though persisting into the early Roman period.
- 5.2.21 **Roman.** A relatively small area of Roman activity was identified in the eastern portion of the site in Land Parcel 8 and extending across into Land Parcel 7c. This was represented principally by ditched enclosures yielding a concentrated and well-preserved assemblage of early Roman pottery and a fragment of a 1st century AD brooch. The nature of the settlement is difficult to determine due to the limited remains and the poor preservation of environmental and faunal remains. The pottery assemblage was dominated by vessels produced in the local region, with only two imported vessels. Although evaluation did not include any of the cropmark enclosure just east of Land Parcel 8, nor (due to recent services) the surrounding discrete cropmarks, the concentration of Roman activity here may indicate that the cropmark enclosure was Roman, and that the revealed activity was peripheral to this.
- 5.2.22 One of the most significant finds was a fragment of perforated plate or pedestal from Trench 196, providing evidence for pottery production nearby. No further kiln furniture and no pottery wasters were recovered from the site, but a previous phase of evaluation at Hornsby Lane, approximately 2.5km to the north-west, revealed two pottery kilns and none of the surrounding trenches and features produced wasters or other related material (OCA 2020b). This therefore demonstrates that these activities can be relatively circumscribed in area, and so difficult to locate through evaluation alone. As Trench 196 lay on the edge of the evaluated area, the kiln may have lain to the south-east outside the evaluated area.
- 5.2.23 Roman pottery production is well established in the area with numerous kilns recorded within several kilometres of the site at Orsett Cock (Carter 1998), Hornsby Lane (OCA 2020b), Gun Hill (Drury and Rodwell 1973) and Mucking (Lucy and Evans 2016). Another six were also identified approximately 500m to the north of the site in 1955 but were subsequently destroyed before they could be recorded (Barton 1962, 57-104). The excavated examples are broadly dated to the mid-2nd to 3rd centuries, so it is interesting to note that the Roman activity on parcels 7c and 8 appears to come to an end in the 2nd century.
- 5.2.24 Although seemingly more nucleated, the Roman activity on the site overlaps with the middle Iron Age focus. Some pottery in fabrics common to the late Iron Age and early Roman period was found, but this was primarily in association with clearly Roman pottery, so there is no clear evidence for an independent late Iron Age phase of activity, or for continuous settlement from the middle Iron Age into the Roman period on the site.
- 5.2.25 It does however appear that most of the ditches containing Roman pottery follow a NE-SW or NW-SE alignment, forming a broader field system that mirrors the orientation of the cropmarks to the east and west of the site. The

orientation of these boundaries may well have originated in the later prehistoric period, and it is possible that a system of sorts may have become fossilised then, and have continued in use into the early Roman period, whether or not there was continuous settlement activity from Iron Age to Roman periods.

- 5.2.26 Roman finds including CBM and pottery were also recovered from Trenches 5, 32 and 48 in Land Parcel 6, from Trenches 68, 92, 93, 94, 101 and 107 in Land Parcel 7a, Trench 116 in Land Parcel 7b and from Trenches 141 and 149 on the west edge of the evaluation in Land Parcel 7c. The ditches of the cropmark enclosure investigated in Land Parcel 7a contained virtually no finds, the latest finds associated being two small sherds of Roman pottery from Trench 68. While this enclosure had clearly been significantly truncated, and three of the trenches that contained Roman finds (Trenches 92-94) were downslope of this, the paucity of finds is difficult to reconcile with a Roman date, even for a purely agricultural enclosure, and it is perhaps more likely that it is of later date, and that the Roman sherds are residual, along with the few later prehistoric sherds also found associated with it. The other trenches that contain Roman finds are otherwise very scattered, and most likely reflect a broad background of material eroded from upslope, or from manuring onto fields from settlements outside the evaluated area.
- 5.2.27 **Medieval.** Early to middle Saxon activity was limited to two sherds of pottery from a pit in Trench 8 on the elevated northern part of the site. Very few features were recorded in this location and the handful of features that were present are undated. This part of the site occupies a prominent position, and the remains of an undated rectilinear cropmark was also recorded at the crest of the hill. Whether this activity was exclusively early to middle Saxon in date cannot be determined. These features were located at the edge of a plateau that extends to the north and could easily represent activity peripheral to a settlement beyond the site boundary to the east and north. A Saxon settlement was found near Linford some 800m to the east (Barton 1962, 57-104), and a Saxon cemetery overlying the Orsett causewayed enclosure some 800m to the north-west (Hedges and Buckley 1978, 219-308).
- 5.2.28 Limited evidence for late Saxon activity was demonstrated by ditch 4803, which produced several sherds of pottery dated c 900-1050.
- 5.2.29 During the 11th to 13th centuries a distinct phase of activity was identified in Land Parcel 7a. This was primarily focussed in Trenches 92, 93, 94 with a second focus or perhaps peripheral activity also present in Trenches 101 and 84 and consisted of multiple pits. The function of these pits is uncertain and may represent a variety of different activities including storage and waste disposal. The pottery assemblage includes a large number of cooking vessels indicative of a domestic setting and the accompanying environment samples show that oat, wheat, barley and legumes were being processed on the site. Although no evidence of any structures was identified the combined evidence would strongly suggest that a dwelling of some sort would have been present in the vicinity.
- 5.2.30 Trenches 92-94 had been positioned to investigate a rectilinear cropmark feature. Only parts of this proved to correspond to ditches, and these were stratigraphically later than the pit clusters and appear to be entirely unrelated.

The double-ditched cropmark enclosure lay immediately to the north of Trenches 92-94, and it is therefore possible that this was related, perhaps being a stock enclosure adjacent to an open settlement on the lower ground closer to the base of the valley. It is unclear whether the valley had a permanent stream running through it, or whether this was only seasonal, but this seems a plausible interpretation of the limited evidence. The constraints on site prevented trenches from being located to the west of Trench 101, adjacent to the Hoford Road, and alternatively this area could have been an alternative or additional location for settlement.

- 5.2.31 Few medieval finds were recovered from features elsewhere on the site and were probably associated with individuals undertaking agricultural activities as they lack a focus of associated features.
- 5.2.32 **Post-medieval.** Only a handful of post-medieval finds, whether pottery or CBM, were recovered from the site. As with the later medieval findspots, these were probably distributed during agricultural activities. One significant event attributed to this period was the widespread burning evidenced on the surface of the humic soil in Land Parcel 7a. The burnt horizon is quite thick in places, and would have required repeated or sustained land clearance to create it, perhaps suggesting that this area was used repeatedly as the place to dump and burn vegetation from wider land clearance. Finds of brick and pottery from the underlying humic soil suggest this took place in the 19th century, or perhaps even later.
- 5.2.33 Further evidence for intensification and expansion of agricultural practices was provided by the unusual bone-lined drains in Trench 229, 230 and 234. They were loosely date to the 19th century and their apparently haphazard arrangement appears to indicate a localised attempt to improve the ground conditions. The 1st edition Ordnance Survey map does indeed show this portion of the site to be an area of woodland. Presumably these features were put in place when it was decided to reclaim this corner of the field for agricultural purposes.
- 5.2.34 **Undated Features.** Many of the features on the site contained no dating evidence to indicate which phase of activity they belonged to. On the whole it is reasonable to assume that many of these are attributable to dated phases of activity that took place in the immediate vicinity, on a broad basis. For example, there was clearly a late Bronze Age-Iron Age and then early Roman focus in the east of Land Parcel 7c. Given the amount of activity here and the level of truncation, it is reasonable to assume that the undated features are likely to have originated during the earlier phases.
- 5.2.35 The large double-ditched enclosure on Land Parcel 7a provided no reliable dating evidence. It was also not possible to determine if the two ditches were actually contemporary or representative of two separate phases of enclosure. It is tempting with isolated and undated enclosures such as this to assume they were used as stock enclosures, as this can help explain the lack of waste that would be generated in a domestic or industrial setting. This is especially the case in this instance where there appeared to be few internal features. The prominent location of this enclosure, with commanding views to the south and south-west, however seems a waste if this was simply a stock enclosure.

- 5.2.36 The crouched inhumation in Trench 176 did contain sherds of possibly early Neolithic or later prehistoric pottery and a piece of worked flint. These were not, however, grave goods, and thus do not date the burial. An attempt to radiocarbon date the remains was unfortunately unsuccessful due to a lack of collagen. However, the residual finds and the form of the burial with the individual in a crouched position would suggest a date in the Bronze Age or Iron Age.
- 5.2.37 **Features of geological and natural origin.** The site contained a number of discrete sub-circular features categorised as natural in origin, either with or without finds. The vast majority of these were probably tree-throw holes. In earlier prehistory tree-throw holes were sometimes used as shelters during hunting trips, or as repositories for large quantities of finds, and in later periods sometimes contain significant groups of finds, enabling a history of deforestation to be charted.

## 5.3 Evaluation objectives and results

- 5.3.1 **Aims i-iii.** This evaluation established the presence of archaeological remains from the late Upper Palaeolithic through to the post-medieval period. The only clear breaks in activity appear to have been during the early Bronze Age and middle to late Roman periods. Whilst a number of areas were without archaeological features, the nature of the prehistoric activity on the site with its unenclosed and dispersed character means it remains difficult to be confident about establishing areas where remains are likely to be absent.
- 5.3.2 Where present the cropmarks on the site have proven to be reliable. However, the areas of the site without cropmarks have not consistently been without archaeological remains. Although the alignments of the cropmarks can in some instances be extrapolated to help determine the extent of these features. The lack of reliability in the cropmarks derives from a combination of varying depths of colluvium and overburden and also the type of archaeology encountered. The large numbers of discrete features and dispersed flint scatters are inevitably not going to be indicated by cropmarks but constitute a significant proportion of the remains encountered.
- 5.3.3 **Aim iv.** This evaluation has shown the archaeological remains to be present in varying complexity across the site. The variations in complexity have been shown to be the result of either settlement density leading to multiple intercutting features or areas where the topography has allowed for deeper sequences and successive phases of archaeology to develop below colluvium. No complex structures or buildings were encountered during the evaluation but given the range of activity recorded on the site, these should not be ruled out. At the very least pottery kilns, salt-production sites or other industrial areas may well be present. Whilst the *in situ* flint scatters represent both vertically and horizontally complex remains.
- 5.3.4 **Aims v-vi.** The evaluation has established the date of the remains present, the state and preservation of the archaeological artefacts and has provided a good indication about the potential for information about the economy, status and past inhabitants of the site.
- 5.3.5 **Aim vii.** Paleoenvironmental samples were recovered and have demonstrated the state of preservation and level of potential for environmental

information. Overall, the remains recovered from the site were either poorly preserved or produced limited.

- 5.3.6 **Aim xiii.** The evaluation was conducted within the parameters and objectives of the revised East of England Research Framework (Medlycott 2011) and takes account of the aims and objectives of the Greater Thames Estuary Historic Environment Research Framework.
- 5.3.7 **Aim xiv.** The targeting of apparently blank areas has shown that the cropmarks do not provide an accurate representation of the archaeological remains present on this site.
- 5.3.8 **Aim xv.** The evaluation has shown that sites of Mesolithic date do exist on the lower terraces of the valley slopes. The extent of these has been broadly defined and they are predominantly later Mesolithic in date, although there is also evidence for late Upper Palaeolithic, early and middle Mesolithic activity. The assemblage recovered, although large, represents only a small proportion of the material present, and so is insufficient to characterise these sites in detail, but both extensive surface scatters and groups of flint in tree-throw holes and natural hollows are represented.
- 5.3.9 **Aims xvi-xviii.** The depth of the colluvial sequences overlying the Pleistocene geology has been established across much of the site. Buried soil horizons and artefact scatters have also been recognised within these colluvial layers along with the potential for further well-preserved remains. Much of the colluvium is of later prehistoric or later date, although slopewash deposits of much earlier, LUP (late Upper Pleistocene) or early Holocene date have also been recorded. A preserved organic deposit has also been identified and dated to the late Neolithic to late Bronze Age, although environmental preservation is not good.
- 5.3.10 **Aims xix-xx.** Although lacking reliable dating, evidence for dispersed Neolithic and Bronze Age activity has been identified across the site. No burial monuments or cemeteries of this date were identified.
- 5.3.11 **Aim xxi.** The evaluation has shown that the majority of the later prehistoric and Roman activity was focused in the east of the site, although late Bronze Age activity appears to be concentrated in the west in Land Parcel 6 and on the west side of Land Parcel 7c. The late Bronze Age evidence included an assemblage of briquetage, and the presence of a pedestal within this suggests that aspects of salt processing were carried out on the site.
- 5.3.12 The double-ditched rectilinear cropmarks produced little to no dating evidence, while only elements of the smaller rectilinear enclosure appear to be genuine, and the dating appears to be post-14th century and probably post-medieval.
- 5.3.13 **Aim xxii.** Further evidence for pottery production was provided by a single piece of Roman kiln furniture, but no kilns were revealed.
- 5.3.14 **Aims xxiii-xxiv.** No evidence for Roman roads or trackways was revealed and no driveways were identified. The ditches targeted by Trench 9 were not identified. A possible trackway dating to the late medieval or post-medieval period does appear to run along the northern side of the valley as defined by the ditches that run from Trench 90 through to Trench 107 and is later marked on historic mapping.

- 5.3.15 **Aim xxv.** Evidence for medieval settlement was revealed close to the Hoford Road in Trenches 92-94 and 101. It is possible that the double-ditched enclosure just upslope of this was related to this, although not dated. No buildings were recorded, but there was sufficient evidence for domestic activities to suggest it was present nearby.
- 5.3.16 **Aim xxvi.** No trenching was carried out in the vicinity of these buildings.

## Appendix A Trench Tables

Trench 1							
General description						Orientation	E - W
Trench devoid of archaeology. Located on top of dry valley slope. Consists of ploughsoil directly overlying sandy gravel natural to NW and ploughsoil overlying colluvium to SE.						Length (m)	30
						Width (m)	2
						Avg. depth (m)	0.34
Context No.	Type	Fill Of	Width (m)	Depth (m)	Description	Finds	Date
100	Layer			0.34	Ploughsoil. Mid greyish brown sandy silt with frequent pebbles		
101	Layer			0.2	Subsoil. Dark yellowish brown sandy silt colluvial subsoil with frequent pebbles. Only present to east of trench		
102	Layer				Natural. Light yellowish and reddish brown sandy gravel changing to light yellowish brown fine grained clayey silt brickearth-type deposit to East of trench		
Trench 2							
General description						Orientation	NE - SW
Trench devoid of archaeology. Consists of ploughsoil and subsoil overlying colluvial deposits and the natural geology of sand and gravels. Trench shortened to avoid ecological exclusion zone.						Length (m)	20
						Width (m)	2
						Avg. depth (m)	0.4
Context No.	Type	Fill Of	Width (m)	Depth (m)	Description	Finds	Date
200	Layer			0.32	Ploughsoil. Mid greyish brown sandy silt with frequent pebbles		
201	Layer			0.12	Subsoil. Dark yellowish brown sandy silt with frequent pebbles		
202	Layer			0.38	Other Layer. Dark yellowish brown sandy silt with frequent pebbles and infrequent charcoal, brick fragments, CBM and pottery. Possible post-med/modern dumped deposit		
203	Layer			0.06	Buried soil. Pale grey sandy silt. Similar to grey deposits in main dry valley base		
204	Layer				Natural. Light yellowish brown fine grained clayey silt brickearth-type natural		

Trench 3							
General description					Orientation	NE - SW	
Trench revealed a total of five pits, one of which was left unexcavated. It also contained a colluvial layer containing post-medieval material including pottery, nails and an iron key. It was located at base of dry valley slope and consisted of ploughsoil on top of colluvial subsoil, overlying sandy gravel and fine grained slope deposit natural.					Length (m)	30	
					Width (m)	2	
					Avg. depth (m)	0.5	
Context No.	Type	Fill Of	Width (m)	Depth (m)	Description	Finds	Date
300	Layer			0.34	Ploughsoil. Mid greyish brown sandy silt with frequent pebbles		
301	Layer			0.3	Colluvial Layer. mid yellowish brown sandy silt with frequent pebbles		
302	Layer			0.35	Other Layer. Dark greyish brown clayey silt with frequent charcoal and pebbles. Likely modern, contains Iron nail, key and pottery. Possible dumped deposit. Recorded in Section 306 as context 326.		
303	Layer				Natural. Light yellowish brown fine grained clayey silt with patches of sandy gravel		
304	Cut		0.46	0.08	Pit. Steep sides, flat base of oval-shaped discrete		
305	Fill	304	0.46	0.08	Primary Fill. Mid grey brown, some orange mottling, silty clay fill of pit, some small stones		
306	Cut		0.32	0.11	Pit. Steep rounded sides, rounded base.		
307	Fill	306	0.32	0.11	Primary Fill. Mid grey brown silty clay fill, common small stones		
308	Cut		0.58	0.22	Pit. Steep irregular sides with irregular base. Bioturbated		
309	Fill	308	0.58	0.22	Primary Fill. Mid grey brown silty clay, some stones.		
310	Unexc feature		0.3		Pit. Rounded squarish discrete, mid grey brown fill with some stones.		
311	Layer			0.09	Colluvial Layer. Firm mid red brown gravelly sand with silt.		
312	Layer			0.08	Colluvial Layer. Firm mid red yellow clay sand with some light red yellow mottling.		



313	Cut		1.1	0.53	Natural Feature. Steep sides irregular base of natural layer		
314	Layer		1.1	0.53	Natural. Light grey with orange mottling silty clay	Flint	
315	Layer		0.4	0.14	Colluvial Layer. Mid grey brown with orange mottling common stones		
316	Cut		0.6	0.44	Pit. Steep sided, irregular base		
317	Fill	316	0.6	0.2	Primary Fill. Mid grey sandy silt some stones		
318	Fill	316	0.16	0.15	Primary Fill. Mid mixed grey brown silty clay slumping		
319	Fill	316	0.5	0.24	Secondary Fill. Mid brown sandy silt frequent stones		
320	Fill	313	1.8	0.2	Secondary Fill. Mid mixed yellow brown and grey brown sandy clay, compact. Duplication of 313.	FC	
321	Cut		1.4	0.43	Pit. Cut of pit, cuts colluvium, not bottomed.		
322	Fill	321	1	0.1	Deliberate Backfill. Chaotic mix, light grey clay patches, mid grey brown silty clay, mid red patches. frequent stones.		
323	Fill		1.4	0.3	Tertiary Fill. 1.26 length Colluvium like fill of pit mid grey brown compact silty clay, frequent stones, occasional CBM/Daub.	Flint, Pot	Roman
324	Layer		0.09	0.04	Other Layer. Charcoal rich rooting. Dark black brown sandy silt, loose, no inclusions.		
325	Layer		0.6	0.2	Colluvial Layer. Light grey silty clay, compact, frequent stones. not based. Same as 326.		
326	Layer			0.45	Colluvial Layer. Firm olive brown Sandy silt contains charcoal. Same as 325.	Pot, Cu, Fe, A. Bone	c 1480-1600
327	Layer			0.8	Colluvial Layer. Firm mid yellowish brown Sandy silt.	Pot	c 1480-1600

#### Trench 4

General description						Orientation	N-S
Trench located towards top of dry valley slope. Consists of ploughsoil overlying a stony colluvium that overlies a colluvial layer containing prehistoric pottery and charcoal. This overlies a light yellowish brown fine grained slope deposit.						Length (m)	30
						Width (m)	6
						Avg. depth (m)	1.5
Context No.	Type	Fill Of	Width (m)	Depth (m)	Description	Finds	Date

400	Layer			0.35	Ploughsoil. Mid greyish brown sandy silt with frequent pebbles		
401	Layer			1.15	Colluvial Layer. Mid to dark yellowish brown sandy silt with frequent pebbles and infrequent charcoal and pottery		
402	Layer			0.3	Colluvial Layer. Mid to light yellowish brown slightly clayey sandy silt with moderately frequent pebbles and infrequent charcoal and pottery	Pot	LBA-EIA
403	Layer				Natural. Mottled, light yellowish brown clayey silt with frequent pebbles		
404	Layer			0.34	Colluvial Layer. Dark greyish brown sandy silt. Colluvial topsoil, very frequent inclusions (>50%) rounded and angular stones 1-5cm. Moderate compaction. Clear boundary.		
405	Layer			0.32	Colluvial Layer. Dark yellowish brown sandy silt. Colluvium. Very frequent inclusions (>50%) rounded and angular stones 1-7cm. Moderate compaction. Diffuse boundary.		
406	Layer			0.16	Colluvial Layer. Dark yellowish brown sandy silt. Frequent inclusions (>30%) rounded and angular stones 1-5cm. Loose. Diffuse boundary.		
407	Layer			0.22	Colluvial Layer. Dark yellowish brown clayey silt with fine grained sand. Frequent (>30%) rounded and angular stones 1-4cm. Loose. Diffuse boundary.		
408	Layer			0.2	Colluvial Layer. Dark yellowish brown sandy silt. Frequent inclusions (>30%) of rounded stones 1-4cm. Loose. Diffuse boundary.		
409	Layer			0.24	Colluvial Layer. Dark yellowish brown clayey silt with fine grained sand. Frequent (>30%) inclusions rounded and angular stones 1-5cm. Loose. Clear boundary.		

410	Layer			0.18	Alluvial Layer. Dark yellowish brown clayey silt with fine grained sand. Common (20%) inclusions rounded and angular stones at top and base of context, 1-5cm. Moderate compaction. Diffuse boundary.	Pot	MBA-MIA
411	Layer			0.2	Alluvial Layer. Dark yellowish brown clayey silt with fine grained sand. Very rare inclusions (<10%) small rounded and angular stones 1-4cm. Moderate compaction. Diffuse boundary.		
412	Layer			0.14	Alluvial Layer. Dark yellowish brown clayey silt with fine grained sand. Common inclusions small rounded stones 1-4cm. Some colour "bleaching" towards northern base of context - appears paler in some areas. Moderate compaction. (Hill wash?)		
413	Layer			0.12	Colluvial Layer. Firm mid greyish yellow clayey sand mottled with a pale grey yellow clay sand.		
414	Layer			0.2	Other Layer. Dark yellowish brown clayey silt, no inclusions, 0.2m thickness. From augering at S401.		
415	Layer			0.2	Other Layer. Dark yellowish brown clayey silt, some pale yellowish "lens' " / "banding" in part of auger core, slightly granular texture throughout. Rare inclusions of small rounded stones 1-4cm diameter Some small manganese flecks within. From augering.		

#### Trench 5

General description					Orientation	NE-SW	
Trench revealed a deep sequence of colluvium and two small stakeholes (one containing prehistoric pottery). The trench was located towards top of dry valley slope.					Length (m)	20	
					Width (m)	6	
					Avg. depth (m)	1.28	
Context No.	Type	Fill Of	Width (m)	Depth (m)	Description	Finds	Date

500	Layer			0.25	Ploughsoil. Mid greyish brown sandy silt		
501	Layer			0.55	Colluvial Layer. mid yellowish brown sandy silt with frequent pebbles	CBM, Pot	Roman
502	Layer			0.32	Colluvial Layer. Light greyish brown sandy silt containing pebbles, pottery, charcoal and burnt flint		
503	Layer			0.55	Colluvial Layer. Mid yellowish brown clayey silt with infrequent pebbles, burnt flint and pottery but moderately frequent charcoal	Pot	MBA-MIA
504	Layer			0.15	Other Layer. Light greenish brown clayey silt. Fine grained slope deposit		
505	Cut		0.56	0.2	Natural Feature. Possible pit tested, found to be natural feature in 501. Not visible in plan or section. 1 small pot fragment found said to be in colluvial fill 501.		
506	Cut		0.1	0.09	Stakehole. Steep sided, pointed base stake hole		
507	Fill	506	0.1	0.09	Secondary Fill. Mid grey with black flecks silty sand fill where stake post would have been	Pot	MBA-MIA
508	Cut		0.05	0.15	Stakehole. Vertical sided slightly pointed base, cut of stakehole		
509	Fill	508	0.05	0.15	Secondary Fill. Dark grey black silty sand fill		
510	Layer			0.1	Buried soil. Firm brownish grey slightly clayey silt with rare charcoal.		

### Trench 6

General description						Orientation	NE-SW
Trench consists of ploughsoil on top of colluvium which overlies a dark yellowish brown layer containing charcoal and pottery						Length (m)	30
						Width (m)	2
						Avg. depth (m)	1
Context No.	Type	Fill Of	Width (m)	Depth (m)	Description	Finds	Date
600	Layer			0.3	Ploughsoil. Mid greyish brown sandy silt		
601	Layer			0.4	Colluvial Layer. Light yellowish brown sandy silt		
602	Layer				Colluvial Layer. Dark yellowish brown clayey silt containing charcoal and pottery		

<b>Trench 7</b>							
General description					Orientation	NE-SW	
Trench revealed one gully N-S. Consists of ploughsoil and subsoil overlying possible Pleistocene aeolian and gravelly head deposits. Towards the south-west end of the trench the head deposit is overlain by a brick earth deposit. only visible in this end of the trench.					Length (m)	30	
					Width (m)	2	
					Avg. depth (m)	0.5	
Context No.	Type	Fill Of	Width (m)	Depth (m)	Description	Finds	Date
700	Layer			0.28	Ploughsoil. Mid greyish-brown sandy silt		
701	Layer			0.18	Subsoil. Mid yellowish brown sandy silt		
702	Layer			0.12	Natural. Light yellowish brown sandy silt. Possible Pleistocene aeolian deposit		
703	Layer			0.25	Natural. Mid yellowish brown, slightly clayey sandy silt. Possible Pleistocene aeolian deposit		
704	Layer			0.1	Natural. Mid reddish brown, slightly clayey sandy silt with frequent pebbles. Possible Head deposit.		
705	Cut		0.5	0.08	Ditch		
706	Fill	705	0.5	0.08	Other Fill. Light grey compacted silty sand		
<b>Trench 8</b>							
General description					Orientation	NW-SE	
Trench revealed a single pit, consisted of ploughsoil and subsoil overlying natural geology of silty sand.					Length (m)	30	
					Width (m)	2	
					Avg. depth (m)	0.42	
Context No.	Type	Fill Of	Width (m)	Depth (m)	Description	Finds	Date
800	Layer			0.35	Ploughsoil. Mid greyish brown sandy silt.		
801	Layer			0.12	Subsoil. Mid reddish brown silty sand.		
802	Layer				Natural. Mid reddish yellowish brown silty sand.		
803	Cut		1.12	0.37	Pit		
804	Fill	803	1.12	0.32	Other Fill. Mid greyish brown silty sand and gravel	Pot	c 400-750
<b>Trench 9</b>							
General description					Orientation	E-W	
					Length (m)	30	
					Width (m)	2	

Trench revealed a single pit. Consists of ploughsoil and subsoil overlying natural geology redeposited sandy terrace gravels, possibly redeposited Thanet Sand and sandy terrace gravels						Avg. depth (m)	0.4
Context No.	Type	Fill Of	Width (m)	Depth (m)	Description	Finds	Date
900	Layer			0.3	Ploughsoil. Mid greyish-brown sandy silt	Fe	Mod
901	Layer			0.15	Subsoil. Mid yellowish brown sandy silt		
902	Layer			0.12	Other Layer. Light yellowish brown sandy gravel.		
903	Cut		0.73	0.24	Pit		
904	Fill	903	0.73	0.27	Other Fill. Mid brownish grey silty sand and gravel		
905	Layer			0.21	Natural. Light yellowish brown, pinkish sandy gravel		
906	Layer			0.04	Natural. Light yellowish brown sandy silt		
907	Layer			0.07	Natural. Pale grey silty sand with frequent pebbles		
908	Layer			0.15	Natural. Light yellowish brown fine sand with angled reddish brown sand and stony laminations		
909	Layer				Natural. Mid reddish brown to light yellowish brown sandy gravel. Terrace gravel.		

### Trench 10

General description						Orientation	E-W
Trench revealed one ditch ESE-WNW and one ditch terminus N-S. One natural feature investigated. Trench consists of ploughsoil and subsoil overlying natural geology of silty sand and gravel.						Length (m)	30
						Width (m)	2
						Avg. depth (m)	0.38
Context No.	Type	Fill Of	Width (m)	Depth (m)	Description	Finds	Date
1000	Layer			0.2	Ploughsoil. Mid greyish-brown silty sand		
1001	Layer			0.16	Subsoil. Light greyish-brown silty sand		
1002	Layer				Natural. Light reddish-brown and mid reddish-brown silty sand		
1003	Cut		0.77	0.42	Ditch		
1004	Fill	1003	0.77	0.42	Primary Fill. Mid brownish grey friable coarse sand		
1005	Cut		0.7	0.28	Ditch		
1006	Fill	1005	0.7	0.28	Secondary Fill. Mid greyish brown silty sand and gravel		
1007	Cut				Natural Feature		

<b>Trench 11</b>							
General description					Orientation		E-W
Trench revealed a single ditch. It consisted of ploughsoil and colluvium overlying natural geology of possible redeposited River terrace gravels and Thanet sand.					Length (m)		30
					Width (m)		2
					Avg. depth (m)		0.79
Context No.	Type	Fill Of	Width (m)	Depth (m)	Description	Finds	Date
1100	Layer			0.35	Ploughsoil. Mid greyish-brown sandy silt.		
1101	Layer			0.44	Colluvial Layer. Mid reddish brown sandy silt.		
1102	Layer			0.18	Natural. Mid reddish brown-greyish brown sandy silt. Redeposited River terrace gravels?		
1103	Layer			0.13	Natural. Mid greyish brown silty sand. Redeposited River terrace gravels?		
1104	Layer			0.09	Natural. Light reddish brown silty sand. Redeposited River terrace gravels.		
1105	Layer				Natural. Light yellowish green silty sand. Redeposited Thanet sand?		
1106	Cut		1.46	0.14	Ditch. Irregular ditch orientated NW-SE		
1107	Fill	1106	1.46	0.14	Primary Fill. Light brownish silty clay with some pieces of pottery	Pot	c 1050-1200?
<b>Trench 12</b>							
General description					Orientation		N-S
Trench devoid of archaeology. Consists of ploughsoil overlying natural geology of two possible river terrace gravels and Thanet sand deposit.					Length (m)		30
					Width (m)		2
					Avg. depth (m)		0.45
Context No.	Type	Fill Of	Width (m)	Depth (m)	Description	Finds	Date
1200	Layer			0.32	Ploughsoil. Mid greyish brown sandy silt.		
1201	Layer			0.25	Natural. Light reddish brown silty sand. Redeposited River terrace gravels?		
1202	Layer			0.12	Natural. Dark reddish brown silty sand. Redeposited River terrace gravels?		
1203	Layer				Natural. Light greenish yellow silty sand.		

					Redeposited Thanet sand?		
<b>Trench 13</b>							
General description					Orientation	E-W	
Trench devoid of archaeology. Consists of ploughsoil and colluvium overlying natural geology of Pleistocene aeolian deposit, redeposited River terrace gravels and Thanet sand.					Length (m)	30	
					Width (m)	2	
					Avg. depth (m)	0.75	
Context No.	Type	Fill Of	Width (m)	Depth (m)	Description	Finds	Date
1300	Layer			0.3	Ploughsoil. Mid greyish brown sandy silt.		
1301	Layer			0.45	Colluvial Layer. Mid reddish brown slightly clayey and sandy silt.		
1302	Layer			0.17	Natural. Mid greyish brown moderately clayey and sandy silt. Pleistocene aeolian deposit?		
1303	Layer			0.1	Natural. Dark reddish brown sandy silt. Redeposited River terrace gravels?		
1304	Layer				Natural. Light yellowish green silty sand. Redeposited Thanet sand?		
<b>Trench 14</b>							
General description					Orientation	E-W	
Trench devoid of archaeology. Consists of ploughsoil and subsoil overlying natural geology of silty sand.					Length (m)	30	
					Width (m)	2	
					Avg. depth (m)	0.42	
Context No.	Type	Fill Of	Width (m)	Depth (m)	Description	Finds	Date
1400	Layer			0.3	Ploughsoil. Dark grey silty sand		
1401	Layer			0.11	Subsoil. Orangey brown silty sand		
1402	Layer				Natural. light reddish brown sandy gravel		
<b>Trench 15</b>							
General description					Orientation	N-S	
Trench devoid of archaeology. Consists of ploughsoil and subsoil overlying natural of sandy silt and gravel. Middle of the trench contains redeposited gravel, within a gravel fan. These overlie possible head deposit.					Length (m)	30	
					Width (m)	2	
					Avg. depth (m)	0.5	
Context No.	Type	Fill Of	Width (m)	Depth (m)	Description	Finds	Date
1500	Layer			0.3	Ploughsoil. Mid greyish brown sandy silt		



1501	Layer			0.2	Colluvial Layer. Mid reddish brown sandy silt		
1502	Layer			0.14	Natural. Light yellowish brown very sandy silt. Pleistocene aeolian deposit		
1503	Layer			0.04	Colluvial Layer. Dark yellowish brown very sandy silt with frequent pebbles		
1504	Layer			0.12	Colluvial Layer. Mid greyish brown very sandy silt gravel fan		
1505	Layer			0.16	Natural. Slightly greenish yellowish brown silty sand with frequent pebbles. Possible head deposit		

### Trench 16

General description					Orientation	E-W	
Trench devoid of archaeology. Consists of ploughsoil and colluvium overlying natural geology of silty sand.					Length (m)	30	
					Width (m)	2	
					Avg. depth (m)	0.52	
Context No.	Type	Fill Of	Width (m)	Depth (m)	Description	Finds	Date
1600	Layer			0.45	Ploughsoil. Mid greyish brown sandy silt.		
1601	Layer			0.11	Colluvial Layer. Mid reddish brown sandy silt.		
1602	Layer			0.14	Natural. Light reddish brown silty sand. Pleistocene aeolian deposit?		
1603	Layer			0.08	Natural. Mid reddish brown silty sand. Pleistocene aeolian deposit?		

### Trench 17

General description					Orientation	E-W	
Trench revealed one pit. Consists of ploughsoil and colluvium overlying natural geology of sandy silt.					Length (m)	30	
					Width (m)	2	
					Avg. depth (m)	0.3	
Context No.	Type	Fill Of	Width (m)	Depth (m)	Description	Finds	Date
1700	Layer			0.3	Ploughsoil. Mid greyish brown sandy silt.		
1701	Layer			0.27	Colluvial Layer. Mid reddish brown sandy silt.		
1702	Layer				Natural. Mid yellowish brown silty sand.		

					Pleistocene aeolian deposit.		
1703	Cut		1.02	0.16	Pit		
1704	Fill	1703	1.02	0.16	Deliberate Backfill. Mottled reddish greyish brown silty sand.	Flint, Pot	LIA-ER

### Trench 18

General description					Orientation	E-W	
Trench devoid of archaeology. Consists of ploughsoil and subsoil overlying natural of silty sand.					Length (m)	30	
					Width (m)	2	
					Avg. depth (m)	0.5	
Context No.	Type	Fill Of	Width (m)	Depth (m)	Description	Finds	Date
1800	Layer			0.3	Ploughsoil. Mid greyish-brown silty sand		
1801	Layer			0.55	Subsoil. Mid reddish-brown silty sand		
1802	Layer				Natural. Dark reddish-brown sand		

### Trench 19

General description					Orientation	N-S	
Trench devoid of archaeology. Consists of ploughsoil and subsoil overlying natural of silty sand.					Length (m)	30	
					Width (m)	2	
					Avg. depth (m)	0.8	
Context No.	Type	Fill Of	Width (m)	Depth (m)	Description	Finds	Date
1900	Layer			0.2	Ploughsoil. Mid greyish-brown silty sand		
1901	Layer			0.6	Colluvial Layer. Mid reddish-brown silty sand		
1902	Layer				Natural. Mid to light yellowish-red grey silty sand		

### Trench 20

General description					Orientation	NE-SW	
Trench devoid of archaeology. Consisted of ploughsoil and subsoil overlying a colluvial layer and natural geology of silty sand. Pottery was recovered from the colluvium.					Length (m)	30	
					Width (m)	2	
					Avg. depth (m)	0.6	
Context No.	Type	Fill Of	Width (m)	Depth (m)	Description	Finds	Date
2000	Layer			0.3	Ploughsoil. Mid greyish-brown silty sand		
2001	Layer			0.3	Colluvial Layer. Mid reddish-brown silty sand		

2002	Layer				Natural. Mid yellowish-red silty sand		
2003	Layer		3.75	0.26	Colluvial Layer. Firm mid greyish brown sandy silt	Flint	

Trench 21							
General description					Orientation		NW-SE
Trench devoid of Archaeology. Consists of ploughsoil and subsoil overlying natural geology of silty sand. 2 chalk bands visible at lower levels within trench					Length (m)		30
					Width (m)		2
					Avg. depth (m)		0.7
Context No.	Type	Fill Of	Width (m)	Depth (m)	Description	Findings	Date
2100	Layer			0.2	Ploughsoil. Mid greyish-brown slightly clayey silt		
2101	Layer			0.5	Colluvial Layer. Mid yellowish brown mottled with light grey sandy silt		
2102	Layer				Colluvial Layer. Dark yellowish brown clayey silt		
2103	Layer			0.11	Colluvial Layer. Mid yellowish brown mottled with light grey. Slightly clayey silt.		
2104	Layer			0.35	Colluvial Layer. Light greyish brown slightly clayey silt mottled by calcific bands.		
2105	Layer			0.28	Colluvial Layer. Light yellowish brown silty sand, mottled with light grey and Calcific sediment.		
2106	Layer			0.08	Other Layer. Mid yellowish brown slightly clayey silt mottled by abundant manganese		
2107	Layer			0.09	Other Layer. Mid greyish yellowish brown, slightly silty sand		
2108	Layer			0.23	Other Layer. Mid yellowish brown clayey silt, mottled with abundant manganese specks		
2109	Layer			0.1	Other Layer. Darker mid yellowish brown silty sand		
2110	Layer			0.2	Colluvial Layer. Light greyish brown clayey		

					silt mottled with mid yellowish brown		
2111	Layer			0.12	Colluvial Layer. Mottled Sandy clay. Lt grey yellow timid red yellow.		
2112	Layer			0.16	Colluvial Layer. Mid grey yellow clay sand		
2113	Layer			0.25	Colluvial Layer. Light grey yellow clay sand		
2114	Layer			0.08	Colluvial Layer. Light grey yellow chalky clay		
2115	Layer			0.18	Colluvial Layer. Light red yellow slightly clayey sand		
2116	Layer			0.12	Colluvial Layer. Mid grey red slightly clayey sand		
2117	Layer			0.03	Colluvial Layer. Light grey yellow chalky clay		
2118	Layer			0.47	Colluvial Layer. Light red yellow slightly clayey sand with 1cm bands of mid grey yellow clay sand.		

### Trench 23

General description					Orientation	E-W	
Trench devoid of Archaeology. Consists of ploughsoil and subsoil overlying natural geology of silty sand.					Length (m)	30	
					Width (m)	2	
					Avg. depth (m)	0.45	
Context No.	Type	Fill Of	Width (m)	Depth (m)	Description	Finds	Date
2300	Layer			0.25	Ploughsoil. Mid greyish-brown silty sand		
2301	Layer			0.2	Subsoil. Light greyish-brown silty sand		
2302	Layer				Natural. Mid reddish-brown silty sand		

### Trench 24

General description					Orientation	N-S	
Trench devoid of archaeology. Consisted of ploughsoil and colluvial subsoil overlying the natural geology. A single natural feature was tested.					Length (m)	30	
					Width (m)	2	
					Avg. depth (m)	0.75	
Context No.	Type	Fill Of	Width (m)	Depth (m)	Description	Finds	Date
2400	Layer			0.3	Ploughsoil. Light greyish-brown silty sand		
2401	Layer			0.4	Subsoil. Mid reddish-brown silty sand		
2402	Layer				Natural. Light reddish-grey silty Sand		

2403	Cut		0.7	0.13	Natural Feature. Light grey silty sand		
<b>Trench 25</b>							
General description					Orientation	NW-SE	
Trench contains ploughsoil, subsoil, colluvium deposits overlying Thanet sands. It also contained a buried soil horizon similar to that in Trench 26. Palaeochannel deposits to the western end of trench.					Length (m)	30	
					Width (m)	2	
					Avg. depth (m)	0.7	
Context No.	Type	Fill Of	Width (m)	Depth (m)	Description	Finds	Date
2500	Layer			0.3	Ploughsoil. Dark greyish yellowish brown very slightly clayey silt		
2501	Void						
2502	Layer				Subsoil. Mid greyish brown sandy silt		
2503	Layer			0.43	Colluvial Layer. Pale yellowish brown mottled with mid reddish brown slightly clayey silt, Freq flecks of charcoal and ceramic. To North western end of trench.		
2504	Layer			0.12	Colluvial Layer. Olive greenish brown mottled with mid reddish brown slightly clayey silt		
2505	Layer			0.14	Other Layer. Very dark brown slightly clayey silt. Peaty soil		
2506	Layer			0.19	Other Layer. Dark greyish brown clayey silt		
2507	Layer			0.11	Buried soil. Light grey heavily mottled with mid greyish brown sediment, slightly clayey silt.		
2508	Layer			0.35	Other Layer. Pale greenish grey mottled with mid yellowish brown clayey silt		
2509	Layer				Other Layer. Banded silts and sand in base of trench. Pleistocene slope deposit.		
2510	Layer				Other Layer. Pleistocene slope deposit		
<b>Trench 26</b>							
General description					Orientation	NE-SW	
					Length (m)	30	

Trench devoid of archaeology. Consisted of ploughsoil overlying two deposits of colluvium and a buried soil deposit. Grey deposit with flint at NE end.					Width (m)	6	
					Avg. depth (m)	1.8	
Context No.	Type	Fill Of	Width (m)	Depth (m)	Description	Finds	Date
2600	Layer			0.35	Ploughsoil. Mid greyish-brown sandy silt, varies throughout trench to a slightly clayey silt		
2601	Layer			0.55	Colluvial Layer. light yellowish brown slightly clayey silty sand, mottling of dark yellow in North part of trench		
2602	Layer			0.28	Colluvial Layer. Mid grey mottled with mid reddish brown and mid yellowish brown. Sandy silt		
2603	Layer			0.21	Colluvial Layer. Dark greyish brown mottled with mid reddish brown. Slightly clayey sandy silt		
2604	Layer			0.2	Buried soil. Very dark blackish brown sandy silt		
2605	Layer			0.2	Colluvial Layer. Light-mid grey mottled with light-mid yellowish brown. Slightly clayey silt		
2606	Layer			0.12	Colluvial Layer. Pale greyish brown slightly clayey silt with mid yellowish brown mottling		
2607	Layer			0.27	Colluvial Layer. Mid greyish brown slightly clayey silt with mottling of mid yellowish brown		
2608	Layer			0.05	Colluvial Layer. Mid greyish brown, subtle mottling of mid yellowish brown. Slightly clayey sand		
2609	Layer			0.16	Other Layer. Light olive brown mottled with mid yellowish brown. Sandy silt		
2610	Layer			0.27	Colluvial Layer. Firm dark grey brown clay sand		
2611	Layer			0.23	Colluvial Layer. Firm light grey yellow Sandy clay		
2612	Layer			0.5	Colluvial Layer. Firm light red yellow Sandy clay		

2613	Layer			0.15	Colluvial Layer. Soft light red yellow Sandy clay		
2614	Layer			0.13	Other Layer. Mineral Palaeosol. Dark brown mottled slightly sandy silt, mottled with light yellowish brown sediment		
<b>Trench 27</b>							
General description					Orientation	NE-SW	
Trench revealed a linear ditch. It comprised plough soil and subsoil and colluvium overlying a natural of mid yellowish red sandy clay.					Length (m)	30	
					Width (m)	6	
					Avg. depth (m)	1.15	
Context No.	Type	Fill Of	Width (m)	Depth (m)	Description	Finds	Date
2700	Layer			0.35	Ploughsoil. Mid greyish-brown silty sand		
2701	Layer			0.55	Subsoil. Mid greyish-red silty sand		
2702	Layer				Natural. Mid yellowish-red sandy clay		
2703	Cut		0.47	0.19	Ditch. Linear ditch (10m+ in length) located towards SW end of TR27		
2704	Fill	2703	0.47	0.19	Secondary Fill. Firm light greyish orange clayey sand with inclusions of naturally-occurring flint		
2705	Cut		0.28	0.16	Natural Feature. Irregular natural feature located to the north central of TR27.		
2706	Fill	2705	0.28	0.16	Secondary Fill. Firm light grey silt		
2707	Layer				Colluvial Layer. Chalky mid yellowish white layer, possibly from rooting		
2708	Layer				Colluvial Layer. Very compacted light orange grey colluvial layer.	Flint	
2709	Layer				Other Layer. Very firm light grey brown silty clay layer on north bulk of Tr 27 in the centre of the trench.		
2710	Cut		0.17	0.02	Natural Feature. Irregular natural feature in the N part of Tr 27.		
2711	Fill	2710	0.17	0.02	Secondary Fill		

<b>Trench 28</b>							
General description					Orientation	N-S	
Trench consists of ploughsoil on top of subsoil and numerous layers of colluvium at various points of the trench. At the northern end, the colluvial layers (2805) and (2808) overly a clayey silt natural. At the southern end the colluvium (2802) overlies a buried soil or land surface which overlies a clayey silt natural. In the middle of the trench a possible ditch terminus [2806] extends into the eastern section (drawing #2800).					Length (m)	30	
					Width (m)	6	
					Avg. depth (m)	0.65	
Context No.	Type	Fill Of	Width (m)	Depth (m)	Description	Finds	Date
2800	Layer			0.3	Ploughsoil. Mid greyish brown sandy silt		
2801	Layer			0.24	Subsoil. Mid yellowish brown sandy silt		
2802	Layer			0.2	Colluvial Layer. Mid reddish brown sandy silt present at southern end of trench		
2803	Layer			0.8	Buried soil. Light blueish grey sandy silt with moderately frequent charcoal flecks and iron mottling present at Southern end of trench		
2804	Layer				Natural. Light orangish brown clayey silt with patches of blueish grey		
2805	Layer			0.28	Colluvial Layer. Light yellowish orange clayey silt with patches of blueish grey present at northern end of trench		
2806	Cut		1.15	0.65	Ditch. Possible ditch terminus present towards northern end of trench along Eastern section edge		
2807	Fill	2806	1.15	0.65	Secondary Fill. Light/pale blueish grey clayey sand with small patches of yellowish orange and relatively frequent flecks of charcoal inclusions.	Flint	
2808	Layer				Colluvial Layer		
2809	Cut				Pit		
2810	Fill	2809			Secondary Fill		
2811	Fill	2809			Secondary Fill		
<b>Trench 29</b>							
General description					Orientation	N-S	
					Length (m)	30	
					Width (m)	6	



Trench devoid of archaeology. Consisted of ploughsoil and subsoil overlying a colluvium layer on top of the natural geology of sand and gravels						Avg. depth (m)	1.79
Context No.	Type	Fill Of	Width (m)	Depth (m)	Description	Finds	Date
2900	Layer			0.24	Ploughsoil. dark brown grey silt sand	Flint	
2901	Layer			0.15	Subsoil. mid yellow brown silt sand		
2902	Layer			1.68	Colluvial Layer. Mid yellow brown sand silt		
2903	Layer				Natural. mid yellow brown sands and gravel		

<b>Trench 30</b>							
General description						Orientation	NE-SW
Trench devoid of archaeology. Consisted of ploughsoil and subsoil overlying the natural geology of sand						Length (m)	30
						Width (m)	2
						Avg. depth (m)	0.6
Context No.	Type	Fill Of	Width (m)	Depth (m)	Description	Finds	Date
3000	Layer				Natural		
3001	Layer			0.4	Colluvial Layer. Light yellowish, slightly mottled clayey sand. OCC worked flint flakes. Debitage	Flint	
3002	Layer			0.25	Subsoil. Mid reddish brown sandy silt		
3003	Layer				Ploughsoil. Dark reddish brown silt		
<b>Trench 31</b>							
General description						Orientation	E-W
Trench consists of plough soil, subsoil of colluvium overlying upper bleached horizon, upper slope deposits, lower bleached horizons and slope deposits with Pleistocene deposits						Length (m)	30
						Width (m)	6
						Avg. depth (m)	2
Context No.	Type	Fill Of	Width (m)	Depth (m)	Description	Finds	Date
3100	Layer				Natural. Light yellowish brown, light bluish grey and white sandy silt		
3101	Layer		6	0.2	Colluvial Layer. Mid brownish grey sandy clayey silt		
3102	Layer		6	0.2	Colluvial Layer. Light reddish brown and light brownish grey sandy clayey silt.		
3103	Layer			0.25	Ploughsoil. Mid brownish grey clayey silt		

3104	Layer		6	0.2	Buried soil. Mixed mid brownish grey and light greyish brown sandy clayey silt	Pot	MBA-MIA
3105	Layer		6	0.15	Buried soil. Soft light grey fine sandy silt		
3106	Layer		6	0.1	Buried soil. Soft light grey and light greenish grey silt	Flint	
3107	Layer		2	0.5	Colluvial Layer. Soft mixed light grey and mid orange red clay silt		
3108	Layer		2	0.15	Colluvial Layer. Soft mixed light grey and light brownish red sandy silt	Flint	
3109	Layer		2	0.1	Buried soil. Soft light bluish grey fine sandy silt		
3110	Layer		2		Colluvial Layer. soft mid to dark brownish red with light brownish grey clay silt		
3111	Layer		2	0.45	Other Layer. Firm light brownish red and light brownish grey clayey silt. Slope deposit.		
3112	Layer		2	0.35	Colluvial Layer. Firm light brownish grey and light brownish grey sandy silt. Slope deposit.		
3113	Layer		2	0.1	Other Layer. Soft light greyish brown and mid bluish grey sandy silt. Bleached slope deposit.		

### Trench 32

General description					Orientation	NW-SE	
Trench revealed two ditches, each partially truncated by machining. Consisted of Ploughsoil, subsoil overlaying a colluvial layer and a clayey sand natural. Excavated to a depth of 2m.					Length (m)	30	
					Width (m)	6	
					Avg. depth (m)	0.4	
Context No.	Type	Fill Of	Width (m)	Depth (m)	Description	Finds	Date
3200	Layer		6	0.87	Other Layer. Soft mixed mid yellowish brown and light brownish grey sandy clayey silt. Pleistocene slope deposit.		
3201	Layer				Colluvial Layer. Light reddish brown, slightly mottled, clayey silt	Flint	
3202	Layer				Subsoil. Med reddish brown, sandy silt		

3203	Layer				Ploughsoil. Dark reddish brown silt.		
3204	Cut		0.56	0.08	Ditch. N-S aligned ditch		
3205	Fill	3204	0.56	0.08	Primary Fill. Light brownish grey, silty clay, moderate	Pot	Roman
3206	Cut		0.75	0.31	Ditch. Cut of a curvilinear ditch locate in the W side of Trench 32.		
3207	Fill	3206		0.09	Primary Fill. Mod yellowish grey, silty-sand, moderate. Most likely natural redeposit.		
3208	Fill	3206	0.75	0.24	Secondary Fill. Mid brownish grey, silty-clay, moderate. Most likely the result of a natural sedimentation process.		
3209	Cut		2	0.91	Ditch. Poss boundary/enclosure ditch. Machine dug, recorded in section		
3210	Fill	3209	2	0.91	Primary Fill. Mid grey brown, silty- clay, moderate. Machine dug, no inclusions noted on section		
3211	Layer		2	0.4	Other Layer. Soft mixed light yellowish brown and light brownish grey sandy clayey silt. Pleistocene slope deposit		
3212	Layer		2	0.3	Other Layer. Soft mixed mid brownish grey and light yellowish brown lenses of sandy clayey silt. Pleistocene slope deposit.		

### Trench 33

General description					Orientation	NW-SE	
Trench consists of ploughsoil on top of colluvium which overlies a buried iron mineralised soil. Below this is a grey palaeosol, on top of slope deposit/ Thanet sand					Length (m)	30	
					Width (m)	6	
					Avg. depth (m)	0.75	
Context No.	Type	Fill Of	Width (m)	Depth (m)	Description	Finds	Date
3300	Layer			0.3	Ploughsoil. Mid greyish-brown silty sand		
3301	Layer			0.2	Subsoil. Mid reddish-brown silty sand		
3302	Layer				Natural. Light to mid greyish-brown silty sand		

3303	Layer				Colluvial Layer		
3304	Layer				Other Layer. Palaeosol		
3305	Layer			0.12	Buried soil. Sampled, charcoal rich		
<b>Trench 34</b>							
General description					Orientation	NNE-SSW	
Plough soil and a colluvial subsoil overlaying a mid orangish brown natural.					Length (m)	30	
					Width (m)	2	
					Avg. depth (m)		
Context No.	Type	Fill Of	Width (m)	Depth (m)	Description	Finds	Date
3400	Layer				Natural. Mid orangish brown.		
3401	Layer				Subsoil. Mid reddish brown, sandy silt.		
3402	Layer				Ploughsoil. Dark reddish brown.		
<b>Trench 35</b>							
General description					Orientation	E-W	
Trench located at base of dry valley slope. Consists of ploughsoil overlying subsoil which overlies fine grained clayey silt brickearth-type deposit					Length (m)	30	
					Width (m)	2	
					Avg. depth (m)	0.66	
Context No.	Type	Fill Of	Width (m)	Depth (m)	Description	Finds	Date
3500	Layer			0.35	Ploughsoil. Mid greyish brown sandy silt		
3501	Layer			0.28	Subsoil. Light yellowish brown sandy silt colluvial subsoil		
3502	Layer				Natural. Light yellowish brown, slightly reddish clayey silt. Fine grained brickearth-type deposit		
<b>Trench 36</b>							
General description					Orientation	E-W	
Trench located at base of dry valley slope. Consists of ploughsoil overlying subsoil which overlies fine grained clayey silt brickearth-type deposit					Length (m)	30	
					Width (m)	2	
					Avg. depth (m)	0.4	
Context No.	Type	Fill Of	Width (m)	Depth (m)	Description	Finds	Date
3600	Layer			0.32	Ploughsoil. Mid greyish brown sandy silt		
3601	Layer			0.08	Subsoil. Light yellowish brown sandy silt colluvial subsoil		
3602	Layer				Natural. Light yellowish brown, slightly reddish, clayey silt. Fine gained brickearth-type deposit		

<b>Trench 39</b>							
General description					Orientation		NE-SW
Trench devoid of archaeology. Consists in a ploughsoil and subsoil overlying the natural geology of sandy clay.					Length (m)		30
					Width (m)		2.1
					Avg. depth (m)		0.4
Context No.	Type	Fill Of	Width (m)	Depth (m)	Description	Finds	Date
3900	Layer			0.15	Ploughsoil. Dark blackish brown, silty clay.		
3901	Layer			0.22	Subsoil. Mid orangey brown, sandy clay.		
3902	Layer				Natural. Light orangey brown, clayey sand.		
<b>Trench 40</b>							
General description					Orientation		N-S
Trench revealed a spread of burnt flint and charcoal potentially representing part of a burnt mound. Consists of ploughsoil and subsoil overlying natural of sand and gravel. under burnt mound deposit in centre of trench, possible eroded land surface.					Length (m)		30
					Width (m)		2
					Avg. depth (m)		0.4
Context No.	Type	Fill Of	Width (m)	Depth (m)	Description	Finds	Date
4000	Layer			0.3	Ploughsoil		
4001	Layer			0.05	Subsoil		
4002	Layer				Natural		
4003	Layer			0.05	Other Layer. thin light grey layer		
4004	Cut		4.4	0.52	Other Cut. Cut for possible burnt mound		
4005	Fill	4004		0.5	Other Fill. Possible burnt mound		

<b>Trench 41</b>							
General description					Orientation		E-W
Small ditch revealed at the eastern end. Consisted of ploughsoil and subsoil overlying the natural geology of sand and gravel.					Length (m)		30
					Width (m)		2
					Avg. depth (m)		0.55
Context No.	Type	Fill Of	Width (m)	Depth (m)	Description	Finds	Date
4100	Layer			0.32	Ploughsoil. Mid brown grey silty sand		
4101	Layer			0.23	Subsoil. mid red brown silty sand		
4102	Layer				Natural. mid red yellow sand and gravel		
4103	Cut		0.7	0.14	Ditch		
4104	Fill	4103			Secondary Fill. Dark grey brown silt		

<b>Trench 42</b>							
General description					Orientation		E-W
Trench revealed a ditch and a pit towards western end of trench. Consists of ploughsoil and subsoil overlying natural of silty clay.					Length (m)		30
					Width (m)		2
					Avg. depth (m)		0.6
Context No.	Type	Fill Of	Width (m)	Depth (m)	Description	Finds	Date
4200	Cut		0.9	0.28	Ditch		
4201	Fill	4200	0.9	0.28	Primary Fill. Mid greyish brown silty sand with charcoal inclusions		
4202	Layer			0.27	Ploughsoil. Mid greyish brown sandy silt		
4203	Layer			0.43	Subsoil. Mid yellowish brown silty sand		
4204	Layer				Natural. Mid brown orangish silty clay		
4205	Cut		0.3	0.3	Pit. Pit containing 2 burnt fills.		
4206	Fill	4205	0.3	0.3	Primary Fill. Mottled dark grey clayey sand with patches of light grey and orange and charcoal inclusions.		
4207	Fill	4205	0.3	0.2	Secondary Fill. Bright orangish brown clayey sand. Possible burnt fill as indicated by colour.		
4208	Layer			0.12	Colluvial Layer. Pale grey sandy silt layer only present to very west end of trench. Underlies colluvium but on top of natural		
<b>Trench 43</b>							
General description					Orientation		N-S
Trench devoid of archaeology. Consists of ploughsoil overlying natural geology of silty sand.					Length (m)		30
					Width (m)		2
					Avg. depth (m)		0.36
Context No.	Type	Fill Of	Width (m)	Depth (m)	Description	Finds	Date
4300	Layer			0.36	Ploughsoil. Mid greyish brown sandy silt.		
4301	Layer				Natural. Mid reddish brown silty sand.		
<b>Trench 44</b>							
General description					Orientation		NW-SE
Trench devoid of archaeology. Consists of ploughsoil and subsoil overlying natural of silty sand and gravel.					Length (m)		30
					Width (m)		2

						Avg. depth (m)	0.8
Context No.	Type	Fill Of	Width (m)	Depth (m)	Description	Finds	Date
4400	Layer			0.18	Ploughsoil. Dark blackish brown, silty clay.		
4401	Layer			0.35	Subsoil. Mid greyish brown, sandy clay.		
<b>Trench 45</b>							
General description					Orientation		E W
Trench devoid of archaeology, consists of ploughsoil and subsoil overlying the natural geology of sand and gravel					Length (m)		30
					Width (m)		2
					Avg. depth (m)		0.7
Context No.	Type	Fill Of	Width (m)	Depth (m)	Description	Finds	Date
4500	Layer			0.3	Ploughsoil. Dark grey brown sandy silt.		
4501	Layer			0.3	Subsoil. light reddish brown, sandy silt.		
4502	Layer				Natural. Reddish brown sandy gravel		
<b>Trench 46</b>							
General description					Orientation		E-W
Trench devoid of archaeology. Consists of ploughsoil overlying four deposits of colluvium					Length (m)		30
					Width (m)		2
					Avg. depth (m)		1
Context No.	Type	Fill Of	Width (m)	Depth (m)	Description	Finds	Date
4600	Layer			0.25	Ploughsoil. Mid grey brown sandy silt		
4601	Layer			0.18	Colluvial Layer. Dark reddish brown sandy silt	Flint, Pot	MBA-MIA
4602	Layer				Natural. Dark reddish brown clayey sand		
4603	Void						
4604	Void						
4605	Layer			0.08	Buried soil. Dark yellow brown silty sand with elements of clay		
4606	Layer			0.09	Colluvial Layer. Light yellow brown bleached clay sand.		
4607	Layer			0.41	Colluvial Layer. Mid yellow brown clay sand		
4608	Layer			0.54	Colluvial Layer. Mid yellow brown clay sand		
4609	Layer			0.26	Colluvial Layer. Mid yellow clay sand		
4610	Layer			0.2	Colluvial Layer. Mid yellow brown clay sand		

					with white calcium flecks and flint		
4611	Layer			0.44	Colluvial Layer. dark yellowish brown silty sand, mottled in patches to a dark blackish brown		
4612	Layer			0.14	Natural. Light greyish brown slightly silty sand		
<b>Trench 47</b>							
General description					Orientation		E-W
Trench devoid of archaeology. Consisted of ploughsoil overlying subsoil colluvium. Below this a weathered colluvium or brickearth deposit. Another brickearth deposit below overlying natural silt and silty sand. Thanet sand reached at depth of 2.3m in augering.					Length (m)		30
					Width (m)		2
					Avg. depth (m)		0.6
Context No.	Type	Fill Of	Width (m)	Depth (m)	Description	Finds	Date
4700	Layer			0.3	Ploughsoil. Mid greyish brown sandy silt		
4701	Layer			0.2	Colluvial Layer. Dark reddish brown sandy silt	Pot	MBA-MIA
4702	Layer			0.7	Colluvial Layer. Mid yellowish brown sandy silt. Weathered colluvium		
4703	Layer			0.25	Natural. Mid reddish brown silty sand. Brickearth-like deposit		
4704	Layer			0.36	Natural. Light reddish brown slightly clayey silty sand. Pleistocene aeolian deposit.		
4705	Layer			0.2	Natural. Mid yellowish brown silty sand. Pleistocene aeolian deposit		
4706	Layer			0.9	Natural. Mid greyish brown silty sand. Varies in depth from 0.25m upslope (east) to 0.9m downslope (west). Pleistocene aeolian deposit		
4707	Layer			0.4	Natural. Mid greyish brown sandy silt. Varies in depth from 0.15m upslope (east) to 0.4m downslope (west). Pleistocene aeolian deposit		
4708	Layer				Natural. Light greenish brown to blueish grey fine silty sand. Thanet Sand		



4709	Layer			0.5	Natural. Mid reddish brown sandy silt. Pleistocene aeolian deposit		
<b>Trench 48</b>							
General description					Orientation		E-W
Trench revealed several ditches and a pit. Consists of ploughsoil and subsoil overlying natural geology of silty sand and gravel.					Length (m)		30
					Width (m)		2
					Avg. depth (m)		0.48
Context No.	Type	Fill Of	Width (m)	Depth (m)	Description	Finds	Date
4800	Layer				Ploughsoil		
4801	Layer				Subsoil		
4802	Layer				Natural		
4803	Cut		1.7	0.4	Ditch		
4804	Fill	4803	1.7	0.4	Other Fill. Greyish brown silty sand.	Pot	c 900-1050
4805	Cut		1.8	0.08	Pit.		
4806	Fill	4805	1.8	0.08	Other Fill. Mid greyish brown, silty sand		
4807	Cut		0.9	0.14	Ditch.		
4808	Fill	4807		0.14	Other Fill. Light greyish brown, silty sand		
4809	Cut		1.46	0.3	Ditch		
4810	Fill	4809		0.15	Secondary Fill. Dark orange brown silty sand. Charcoal rich and with cbm and bone	CBM, Pot, A. Bone	C15th-C19th
4811	Fill	4809		0.15	Secondary Fill. Light orange brown silty sand with heavy stone inclusions.		
4812	Layer				Subsoil. Mid orange brown silty sand		
4813	Layer		0.8	0.36	Subsoil. mid yellowish brown, sandy silt loose. Frequent natural flint stones and 2 sherds of pottery. Same as (4812)	Pot	Roman
<b>Trench 49</b>							
General description					Orientation		N-S
Trench revealed a single pit, sealed beneath a shallow colluvium, this was overlain by subsoil and ploughsoil. The natural geology comprised silty sand with some gravel.					Length (m)		30
					Width (m)		2
					Avg. depth (m)		0.55
Context No.	Type	Fill Of	Width (m)	Depth (m)	Description	Finds	Date
4900	Layer		2.2	0.25	Ploughsoil		
4901	Layer		2.2	0.18	Subsoil		

4902	Layer		2	0.13	Colluvial Layer. Firm-friable light yellow grey sandy silt.	Flint, Bq	
4903	Cut		1.5	0.4	Pit. Oval, almost vertical sides, base not excavated.		
4904	Fill	4903	1.1	0.3	Secondary Fill. Firm-friable dark brown grey silty sand.	Pot, Bq, A. Bone	LBA
4905	Fill	4903	1.2	0.28	Secondary Fill. Firm-friable mid brown grey silty sand.	Flint, Pot, Bq, A. Bone	LBA
4906	Layer				Natural. Light yellowish brown sandy silt		
4907	Fill	4903	1.1	0.3	Duplicate of 4904	Pot, Bq	LBA

Trench 50							
General description					Orientation		E-W
Trench devoid of archaeology. Consists of ploughsoil and subsoil overlying brickearth like deposits and banded silty sand natural, stony and Thanet sand					Length (m)		30
					Width (m)		6
					Avg. depth (m)		1.2
Context No.	Type	Fill Of	Width (m)	Depth (m)	Description	Findings	Date
5000	Layer			0.27	Ploughsoil. Mid greyish brown sandy silt	Flint	
5001	Layer			0.2	Colluvial Layer. Mid reddish brown sandy silt		
5002	Layer			0.4	Colluvial Layer. Mid to dark reddish brown sandy silt		
5003	Layer			0.06	Other Layer. Mid brown sandy silt. Possible stabilisation horizon or buried soil		
5004	Layer			0.28	Natural. Mid reddish brown silty sand with light yellowish to whitish irregular planar laminations		
5005	Layer			0.1	Natural. Mid reddish brown silt sand with bands of granular pebbles running along slope gradient.		
5006	Layer			0.17	Natural. Mottled, light reddish to yellowish brown silty sand. Possible redeposited or weathered Thanet Sand		
5007	Layer			0.23	Buried soil. Mid greyish brown sandy silt		

5008	Layer			0.19	Colluvial Layer. Light reddish brown sandy silt. Slope deposit		
5009	Layer			0.15	Natural. Mid greyish brown silty sand. Possible redeposited or weathered Thanet Sand		
5010	Layer			0.62	Natural. Mid yellowish brown medium to fine silty sand		
5011	Layer			0.52	Natural. Mid yellowish brown fine to medium silty sand gravel		
5012	Layer			0.8	Natural. Mid yellowish brown medium to coarse clayey sand		
5013	Layer				Natural. Mid to light greenish brown and dark greenish brown fine. Silty sand with light blueish grey fine sandy patches. Thanet Sand		
5014	Layer			0.14	Natural. Dark to mid greyish brown silty sand with frequent granules and small to large pebbles		

#### Trench 51

General description					Orientation	N-S	
Trench devoid of archaeology. Below the ploughsoil and subsoil was an alluvial deposit or possibly a gleyed colluvium containing flecks of charcoal and some scraps of pottery. This was overlying the natural geology of silty clay.					Length (m)	30	
					Width (m)	2	
					Avg. depth (m)	0.4	
Context No.	Type	Fill Of	Width (m)	Depth (m)	Description	Finds	Date
5100	Layer			0.3	Ploughsoil. Mid greyish-brown silty sand		
5101	Layer			0.22	Subsoil. Mid reddish-brown silty sand		
5102	Layer				Natural. Light greyish-brown silty sand		
5103	Layer		10	0.2	Alluvial Layer. Mid greyish-brown Silty sand	Flint	

#### Trench 57

General description					Orientation	E-W	
Trench located on south-west facing slope. Trench devoid of archaeology. Contains topsoil covering colluvium layers and head deposit. The colluvium covers the slope - not bottomed.					Length (m)	30	
					Width (m)	2.1	
					Avg. depth (m)	0.9	
Context No.	Type	Fill Of	Width (m)	Depth (m)	Description	Finds	Date

5700	Layer		2.1	0.4	Topsoil. Mid grey brown, heavily disturbed topsoil silty clay, friable		
5701	Layer		2.1	0.33	Colluvial Layer. Mid greyish brown sandy silt with rounded pebbles. Firm.		
5702	Layer		2.1	0.25	Colluvial Layer. Dark yellowish brown sandy silt. Firm		
5703	Layer			0.2	Other Layer. Reddish brown coarse sand with abundant rounded pebbles. Loose.		

### Trench 58

General description					Orientation	N-S	
Trench devoid of archaeology. Trench consisted of a topsoil of mid grey brown silty sand with a gravelly natural					Length (m)	30	
					Width (m)	2.1	
					Avg. depth (m)	0.5	
Context No.	Type	Fill Of	Width (m)	Depth (m)	Description	Finds	Date
5800	Layer		2.1	0.5	Topsoil. Mid grey brown, silty sand, friable, with modern debris and rooting inclusion		
5801	Layer		2.1	0.1	Natural. Mid yellowish orange, silty sand with gravel patches, firm		

### Trench 59

General description					Orientation	E-W	
Trench devoid of archaeology. Topsoil overlays natural substrate of silty gravel					Length (m)	30	
					Width (m)	2.1	
					Avg. depth (m)	0.4	
Context No.	Type	Fill Of	Width (m)	Depth (m)	Description	Finds	Date
5900	Layer		2.1	0.4	Topsoil. Mid grey brown silty sand with pebbles and grass rooting inclusions		
5901	Layer		2.1		Natural. Mid yellow orange silty gravel, friable		

### Trench 60

General description					Orientation	NE-SW
					Length (m)	30
					Width (m)	2.1

Trench located at west/south facing slope. Trench devoid of archaeology. Consists of a topsoil covering a yellow sand (Head?).						Avg. depth (m)	0.37
Context No.	Type	Fill Of	Width (m)	Depth (m)	Description	Finds	Date
6000	Layer		2.1	0.37	Ploughsoil. Mid grey brown, silty clay, friable		
6001	Layer		2.1		Natural. Mid orange yellow. Silty sand with gravel, friable		
6002	Void						
<b>Trench 61</b>							
General description						Orientation	N-S
Trench located at the top of a south facing slope. Trench contained one pit and three ditches. Trench consists of topsoil covers a possible head deposit - sandy gravel.						Length (m)	30
						Width (m)	2.1
						Avg. depth (m)	0.5
Context No.	Type	Fill Of	Width (m)	Depth (m)	Description	Finds	Date
6100	Layer		2.1	0.5	Ploughsoil. Mid grey brown silty clay, friable		
6101	Layer		2.1	0.1	Colluvial Layer. Light orangey brown, gravel with silty patches		
6102	Layer			0.05	Other Layer. Reddish brown coarse sand with abundant rounded pebbles and cobbles.		
6103	Cut		0.51	0.08	Tree Throw		
6104	Fill	6103	0.51	0.08	Secondary Fill. Dark grey charcoal sandy silt with inclusions of flint stone 2cm in size.		
6105	Cut		0.52	0.14	Ditch		
6106	Fill	6105			Secondary Fill		
6107	Cut				Ditch		
6108	Fill	6107			Secondary Fill		
6109	Cut				Ditch		
6110	Fill	6109			Secondary Fill		
<b>Trench 62</b>							
General description						Orientation	E-W
Trench located at south facing slope. Trench devoid of archaeology and contains a Head deposit covered by colluvium and topsoil.						Length (m)	30
						Width (m)	2.2
						Avg. depth (m)	0.6
Context No.	Type	Fill Of	Width (m)	Depth (m)	Description	Finds	Date
6200	Layer			0.4	Ploughsoil. Dark greyish brown sandy silt with rounded pebbles. Friable.		
6201	Layer			0.2	Colluvial Layer. Mid greyish brown sandy silt		

					with rare rounded pebbles. Friable.		
6202	Layer			0.1	Other Layer. Reddish brown silty sand with common rounded pebbles. Not bottomed. Head.		
<b>Trench 63</b>							
General description					Orientation		N-S
Trench devoid of archaeology. Possible colluvium layer					Length (m)		30
					Width (m)		2.1
					Avg. depth (m)		0.5
Context No.	Type	Fill Of	Width (m)	Depth (m)	Description	Finds	Date
6300	Layer		2.1	0.45	Ploughsoil. Mid grey brown silty sand, friable		
<b>Trench 64</b>							
General description					Orientation		E-W
Trench devoid of archaeology, located on the top of the south/west facing slope. Trench contains a redeposited Thanet Sand covered by clayey Head deposit, stony colluvium and topsoil.					Length (m)		30
					Width (m)		2.1
					Avg. depth (m)		1
Context No.	Type	Fill Of	Width (m)	Depth (m)	Description	Finds	Date
6400	Layer		2.1	0.28	Ploughsoil. Dark grey brown, silty clay, friable		
6401	Layer		2.1	0.1	Colluvial Layer. Mid grey brown sand with rounded pebbles.		
6402	Layer			0.11	Other Layer. Strong brown sandy clay with common rounded pebbles. Firm.		
6403	Layer			0.25	Other Layer. Strong brown clay with common rounded pebbles. Firm.		
6404	Layer			0.08	Other Layer. Mid yellow fine sand. Loose.		
<b>Trench 65</b>							
General description					Orientation		NW-SE
Trench devoid of archaeology. Natural geology of sandy gravel overlain by a silty clay topsoil					Length (m)		30
					Width (m)		2.1
					Avg. depth (m)		0.28
Context No.	Type	Fill Of	Width (m)	Depth (m)	Description	Finds	Date
6500	Layer		2.1	0.23	Ploughsoil. Very dark greyish brown sandy silt with rounded pebbles. Friable.		
6501	Layer		2.1		Natural. Reddish brown coarse sand with		

					rounded pebbles. Loose.		
<b>Trench 66</b>							
General description					Orientation	E-W	
Trench devoid of archaeology. Natural of silty sand overlain by ploughsoil					Length (m)	30	
					Width (m)	2.1	
					Avg. depth (m)	0.4	
Context No.	Type	Fill Of	Width (m)	Depth (m)	Description	Finds	Date
6600	Layer		2.1	0.33	Topsoil. Mid grey brown, silty sand, friable, with modern debris throughout		
6601	Layer		2.1		Natural. Mid yellowish orange, silty sand, friable with gravel inclusions		
<b>Trench 67</b>							
General description					Orientation	N-S	
Trench located at south facing slope. Topsoil covering a colluvium layer and reddish head deposit. Pit recorded in the northern part of the trench. Dug into head and possibly colluvium.					Length (m)	30	
					Width (m)	2.1	
					Avg. depth (m)	0.48	
Context No.	Type	Fill Of	Width (m)	Depth (m)	Description	Finds	Date
6700	Layer		2.1	0.4	Ploughsoil. Mid grey brown silty clay, friable		
6701	Layer		2.1	0.06	Colluvial Layer. Mid orangey brown, silty clay, friable		
6702	Layer		2.1		Natural. Mid yellow orange, silty sand and gravel. Firm		
6703	Cut		0.34	0.07	Pit. Shallow pit		
6704	Fill	6703	0.34	0.07	Primary Fill. Heavy present of charcoal with rare burnt stones	Pit	Neo or MBA-MIA
<b>Trench 68</b>							
General description					Orientation	N-S	
Trench located at the top of South facing slope. Trench contains stony Head deposit and topsoil. Ditch 6802 located at s end, ditch 6805 in centre. Layer 6807 next to ditch 6805 cut by pit 6809, which is cut by ditch 6811. Ditch 6811 not bottomed due to 1m limit.					Length (m)	30	
					Width (m)	2.1	
					Avg. depth (m)	0.34	
Context No.	Type	Fill Of	Width (m)	Depth (m)	Description	Finds	Date
6800	Layer		2.1	0.3	Ploughsoil. Dark greyish brown sandy silt with rounded pebbles. Friable.		
6801	Layer		2.1		Other Layer. Yellowish red coarse sand with		

					rounded pebbles. Loose.		
6802	Cut		1.2	0.26	Ditch. cut of ditch containing 2 fills		
6803	Fill	6802	1.2	0.26	Primary Fill. Primary fill of ditch 6802		
6804	Fill	6802	1.2	0.14	Tertiary Fill. tertiary fill of ditch 6802		
6805	Cut		2.26	0.77	Ditch. Steep sided v shape ditch		
6806	Fill	6805	2.26	0.77	Primary Fill. Mid brown sandy silt full of gravel and some flints	Flint, Pot	Roman?
6807	Cut		2.3	0.2	Natural Feature. VOID - cut not necessary for layer 6808		
6808	Layer		2.3	0.2	Colluvial Layer. Mid grey brown silty sand frequent stones		
6809	Cut		1.3	0.43	Pit. Steep cut of pit, flat base		
6810	Fill	6809	1.3	0.43	Primary Fill. Mid grey brown sandy silt frequent stones		
6811	Cut		1.55	0.6	Ditch. Steep cut of ditch, not based		
6812	Fill	6811	1.55	0.6	Primary Fill. Mid grey brown sandy silt frequent stones		

### Trench 69

General description					Orientation	N-S	
Trench located on the top of a south facing slope. One ditch excavated and one unexcavated ditch, both recorded. Topsoil covering Holocene colluvium recorded. A fine silt recorded at the base - possibly weathered/redeposited Thanet sand but more likely remnant colluvium that seals the north-east corner of the cropmark enclosure. 1 linear present at the south end of trench					Length (m)	30	
					Width (m)	2.1	
					Avg. depth (m)	0.92	
Context No.	Type	Fill Of	Width (m)	Depth (m)	Description	Finds	Date
6900	Layer		2.1	0.45	Ploughsoil. Very dark greyish brown sandy silt with rounded pebbles. Friable.		
6901	Layer		2.1	0.25	Colluvial Layer. Strong brown sandy silt with rare rounded pebbles. Friable.		
6902	Layer		2.1	0.2	Colluvial Layer. Strong brown sandy silt with rare rounded pebbles. Friable.		
6903	Layer		2.1	0.05	Other Layer. Yellowish brown silt. Loose. Present at base of trench in the south-east end. Not bottomed.		



6904	Cut		0.39	0.09	Ditch		
6905	Fill	6904	0.39	0.09	Primary Fill. Mid dark greyish brown, sandy silt	FC, Flint, Pot	MBA-MIA
6906	Unexc feature		1.7		Ditch. Greyish brown sandy silt. Sealed beneath 6906, full width not revealed.		

<b>Trench 70</b>							
General description					Orientation		N-S
Trench located at the south facing slope. Trench devoid of archaeology. Consists of topsoil dark brown grey Sandy silt topsoil covering strong brown Holocene slopewash.					Length (m)		30
					Width (m)		2
					Avg. depth (m)		0.63
Context No.	Type	Fill Of	Width (m)	Depth (m)	Description	Finds	Date
7000	Layer		2.1	0.39	Ploughsoil. Very dark greyish brown sandy silt with rounded pebbles. Friable		
7001	Layer		2.1	0.35	Colluvial Layer. Strong brown clayey silt. Homogeneous and firm.		
7002	Layer			0.18	Colluvial Layer. Strong brown clayey silt. Homogeneous and firm.		
7003	Layer			0.7	Other Layer. Light brown sandy silt with calcite inclusions. Stoneless. Soft.		
7004	Layer			0.04	Other Layer. Light brownish yellow sandy silt. Loose.		
7005	Layer			0.2	Other Layer. Yellow fine sand. Loose.		
<b>Trench 71</b>							
General description					Orientation		E-W
Trench located on the facing slope. Trench devoid of archaeology. Consists of topsoil covering subsoil/colluvium and sand.					Length (m)		30
					Width (m)		2
					Avg. depth (m)		0.6
Context No.	Type	Fill Of	Width (m)	Depth (m)	Description	Finds	Date
7100	Layer		2.1	0.31	Topsoil. Mid grey brown, silty clay, friable, with modern debris inclusions throughout.		
7101	Layer		2.1	0.22	Colluvial Layer. orangey brown, silty sand, friable		

7102	Layer		2.1		Natural. Mid orangey yellow, silty sand with gravel inclusions, friable.		
<b>Trench 72</b>							
General description					Orientation	NE-SW	
Trench devoid of archaeology. Natural geology of silty gravel overlain by a silty clay ploughsoil.					Length (m)	30	
					Width (m)	2.1	
					Avg. depth (m)	0.3	
Context No.	Type	Fill Of	Width (m)	Depth (m)	Description	Finds	Date
7200	Layer		2.1	0.3	Ploughsoil. Mid grey brown silty clay, friable.		
7201	Layer		2.1		Natural. Mid yellowish orange, gravel with silty patches. Firm		
<b>Trench 74</b>							
General description					Orientation	NW-SE	
Trench located at west facing, gentle slope. Trench devoid of archaeology and contains a fine colluvium covered by a stony colluvium with ploughsoil formed on the top.					Length (m)	30	
					Width (m)	2.1	
					Avg. depth (m)	0.8	
Context No.	Type	Fill Of	Width (m)	Depth (m)	Description	Finds	Date
7400	Layer			0.33	Ploughsoil. Very dark greyish brown silt sand with rounded pebbles. Friable.		
7401	Layer			0.18	Colluvial Layer. Greyish brown silty sand with rounded pebbles. Friable.		
7402	Layer			0.2	Colluvial Layer. Mid brown silt sand with rare rounded pebbles. Friable.		
7403	Layer			0.09	Other Layer. Strong brown fine sand with olive patches of sand. Loose. Stoneless.		
<b>Trench 75</b>							
General description					Orientation	E-W	
Trench located at the south/west facing slope. Trench contains one ditch and consists of topsoil covers sandy gravel head deposit.					Length (m)	30	
					Width (m)	2.1	
					Avg. depth (m)	0.5	
Context No.	Type	Fill Of	Width (m)	Depth (m)	Description	Finds	Date
7500	Layer		2.1	0.5	Ploughsoil. Mod grey brown, silty clay, friable		

7501	Layer		2.1		Other Layer. Mid yellow orange, silty sand, gravel. Head deposit. Not bottomed.		
7502	Cut		0.68	0.13	Ditch		
7503	Fill	7502	0.68	0.13	Primary Fill. Mid brown grey, loose silty sand, frequent pebbles		
7504	Layer		0.62	0.08	Remnant Topsoil. Dark greyish brown, loose clay silt		

### Trench 76

General description						Orientation	N-S
Trench contained a single ditch. The trench comprised a stony Head deposit overlain by ploughsoil near the top of a south facing slope.						Length (m)	30
						Width (m)	2.1
						Avg. depth (m)	0.35
Context No.	Type	Fill Of	Width (m)	Depth (m)	Description	Finds	Date
7600	Layer		2.1	0.5	Ploughsoil. Mid grey brown, silty clay, friable		
7601	Layer		2.1		Natural. Mid yellowish orange silty sand gravel, friable		
7602	Void						
7603	Cut		0.8	0.39	Ditch		
7604	Fill	7603	0.8	0.39	Primary Fill. Dark grey, sandy gravel		
7605	Void						
7606	Void						
7607	Cut		0.7	0.22	Ditch		
7608	Fill	7607	0.7	0.22	Secondary Fill. Mid brown greyish silty sand with stone inclusions		

### Trench 77

General description						Orientation	NW-SE
Trench located on the top of the south facing slope. Contains topsoil covering a possible gravelly Head deposit. Ditches cut the Head deposit.						Length (m)	30
						Width (m)	2.1
						Avg. depth (m)	0.5
Context No.	Type	Fill Of	Width (m)	Depth (m)	Description	Finds	Date
7700	Layer				Topsoil. Dark brown silt	Flint	
7701	Layer				Subsoil. Mid-Dark brownish grey silt		
7702	Layer				Natural. Mid orangish brown silt, extremely gravel rich		
7703	Cut		1.6	0.5	Ditch. Straight sided ditch, oriented N-S.		

7704	Fill	7703		0.4	Primary Fill. Mid-Dark yellowish brown silty sand, loose compaction. Gravel rich.		
7705	Fill	7703		0.1	Secondary Fill. Dark brown silty sand, extremely gravel rich.		
7706	Cut		0.64	0.14	Ditch. Shallow ditch orientated W-E		
7707	Fill	7706	0.64	0.14	Primary Fill. Mid brown coarse sand with gravel		
7708	Cut		1.04	0.23	Ditch. Large ditch orientated		
7709	Fill	7708		0.23	Primary Fill. Gravel		
7710	Cut		0.92	0.19	Ditch. Ditch		
7711	Fill	7710	0.92	0.19	Primary Fill. Gravel		
7712	Cut		0.53	0.19	Ditch. Ditch		
7713	Fill	7712	0.53	0.19	Primary Fill		
7714	Cut		1	0.31	Ditch. Linear feature, shallow u-shaped profile.		
7715	Fill			0.31	Primary Fill. Mid-dark greyish brown silty sand, gravel rich.		
7716	Cut		1.5	0.5	Ditch		

### Trench 78

General description					Orientation	NW-SE	
Trench devoid of archaeology. Consists of a topsoil of dark brownish grey silty sand Subsoil reddish brown sandy silt including gravel					Length (m)	30	
					Width (m)	2	
					Avg. depth (m)	0.51	
Context No.	Type	Fill Of	Width (m)	Depth (m)	Description	Finds	Date
7800	Layer		2.1	0.4	Ploughsoil. Mid grey brown silty sand, with rotten potato and rooting inclusions		
7801	Layer		2.1	0.1	Colluvial Layer. reddish brown sandy silt including gravel		
7802	Layer		2.1		Natural. light reddish yellow, silty sand with gravel inclusions		

### Trench 79

General description					Orientation	E-W	
Trench located at south facing slope. Topsoil dark brown grey silty sand covering layers of Holocene colluvium and Pleistocene slopewash. A possible tree throw recorded under colluvium. Trench extended to max depth of 2m on 04.08.2021					Length (m)	30	
					Width (m)	6	
					Avg. depth (m)	0.72	
Context No.	Type	Fill Of	Width (m)	Depth (m)	Description	Finds	Date

7900	Layer			0.31	Ploughsoil. Dark greyish brown sandy silt. Common rounded pebbles. Friable.		
7901	Layer			0.25	Colluvial Layer. Greyish brown sandy silt with common rounded pebbles. Firm.	Pot	MBA-MIA
7902	Layer		0.16		Colluvial Layer. Mid brown silt. Homogeneous and firm. Very rare rounded pebbles.		
7903	Layer			0.32	Colluvial Layer. Strong brown clayey silt. Homogeneous and firm. Stoneless.		
7904	Layer			0.2	Other Layer. Strong brown sandy silt. Homogeneous and firm. Stoneless.		
7905	Layer			0.26	Other Layer. Yellowish brown silt. Homogeneous and firm. Stoneless.		
7906	Layer			0.51	Other Layer. Pale brown silt. Homogeneous and firm with calcite inclusions. Stainless.		
7907	Fill	7909			Secondary Fill. Possible tree throw	FC, Flint	
7908	Fill	7909			Secondary Fill. Possible tree throw		
7909	Cut				Tree Throw		

<b>Trench 80</b>							
General description					Orientation	N-S	
Trench devoid of archaeology, consists of topsoil dark brown grey silty sand Subsoil brownish red Sandy silt					Length (m)	30	
					Width (m)	2	
					Avg. depth (m)	0.68	
Context No.	Type	Fill Of	Width (m)	Depth (m)	Description	Finds	Date
8000	Layer			0.3	Ploughsoil. Dark greyish brown sandy silt with rounded pebbles. Friable.		
8001	Layer			0.2	Colluvial Layer. Strong brown clayey silt. Firm.		
8002	Layer				Other Layer. Pale brown silty sand. Not bottomed.		

<b>Trench 81</b>							
General description					Orientation		E-W
Trench devoid of archaeology. Topsoil sits on top of a colluvium layer. Natural not reached					Length (m)		30
					Width (m)		2
					Avg. depth (m)		0.6
Context No.	Type	Fill Of	Width (m)	Depth (m)	Description	Finds	Date
8100	Layer		2.1	0.28	Ploughsoil. Mid grey brown silty clay, friable		
8101	Layer		2.1	0.2	Colluvial Layer. Mid red brown, silty clay. Firm		
8102	Layer			0.05	Other Layer. Pale brown silty sand with calcite inclusions. Not bottomed		
<b>Trench 82</b>							
General description					Orientation		N-S
Trench located at the base of South facing slope. The lowermost deposits contained homogeneous and oxidised sand followed by a possible stabilisation covered by slopewash. The upper sequence contained humic peaty soil covered by colluvium. Archaeology present in the form of a pit and possible ditch, but sides collapsing and flooded around it					Length (m)		30
					Width (m)		6
					Avg. depth (m)		0.34
Context No.	Type	Fill Of	Width (m)	Depth (m)	Description	Finds	Date
8200	Layer			0.3	Ploughsoil. Dark greyish brown sandy silt with rounded pebbles. Friable.		
8201	Layer			0.2	Colluvial Layer. Dark grey silty clay. Firm. Oxidised.	Pot	c 1580-1800
8202	Layer			0.36	Buried soil. Black humic silt. Stoneless. Soft.		
8203	Layer			0.22	Buried soil. Dark grey silt. Soft. Stoneless.		
8204	Layer			0.17	Colluvial Layer. Pale olive silt. Firm.	Flint	
8205	Layer			0.08	Other Layer. Mid grey clayey silt. Firm.		
8206	Layer			0.3	Other Layer. Olive grey clayey silt. Firm. Stoneless.		
8207	Layer			0.21	Other Layer. Light brownish grey silty sand. Loose. Stoneless.		
8208	Layer			0.27	Other Layer. Light brownish grey sand. Loose. Stoneless.		
8209	Layer				Other Layer. Grey sand with rounded pebbles. Loose.		
<b>Trench 84</b>							
General description					Orientation		E-W

Trench devoid of archaeology, consists of ploughsoil, dark grey sand, and subsoil, medium brown grey silty sand with gravel possibly colluvial layer. A Head deposit and Pleistocene slopewash recorded at the base.					Length (m)	30	
					Width (m)	2	
					Avg. depth (m)	0.38	
Context No.	Type	Fill Of	Width (m)	Depth (m)	Description	Finds	Date
8400	Layer			0.3	Ploughsoil. Dark greyish brown sandy silt with rounded pebbles. Friable		
8401	Layer			0.08	Colluvial Layer. Mid greyish brown sandy silt with rounded pebbles.		
8402	Layer			0.44	Other Layer. Mid yellow clayey sand. Rounded pebbles at the base. Firm.	Flint, Pot	PH
8403	Layer			0.12	Other Layer. Light yellow sand. Oxidised. Very rare rounded pebbles. Soft.		
<b>Trench 85</b>							
General description					Orientation	SE-NW	
Trench contained one ditch. Trench consists of ploughsoil of dark grey sand, subsoil of reddish brown silty sand mixed with gravel, natural of yellow red marbled sand with patches of Thanet Sand					Length (m)	30	
					Width (m)	2	
					Avg. depth (m)	0.47	
Context No.	Type	Fill Of	Width (m)	Depth (m)	Description	Finds	Date
8500	Layer			0.36	Ploughsoil. Very dark grey brownish silty sand with very frequent flint stone inclusions between 1cm to 5cm in size		
8501	Layer			0.23	Colluvial Layer. Dark brown silty sand with very frequent flint stone inclusions ranging from 1cm to 5cm in size		
8502	Layer				Other Layer. Mid yellowish red sand with patches of frequent flint stones 1cm to 5cm in size		
8503	Cut		0.71	0.15	Ditch. Shallow ditch running north to south.		
8504	Fill	8503	0.71	0.15	Secondary Fill. Mid brown stony silty sand, with very frequent flint stones ranging from 1cm to 5cm in size		
8505	Layer			0.1	Natural. Olive yellow fine sand. Yellowish mottling.		
<b>Trench 86</b>							

General description						Orientation	E-W
Trench devoid of archaeology, consisting of ploughsoil of dark grey sand, subsoil of reddish brown silty sand mixed with gravel, natural of yellow red marbled sand						Length (m)	30
						Width (m)	2
						Avg. depth (m)	0.55
Context No.	Type	Fill Of	Width (m)	Depth (m)	Description	Finds	Date
8600	Layer			0.4	Ploughsoil. Very dark greyish brown sandy silt with rounded pebbles.		
8601	Layer			0.17	Other Layer. Reddish brown coarse sand with abundant rounded pebbles. Loose.		
8602	Layer			0.2	Natural. Yellow sand. Stoneless.		
<b>Trench 87</b>							
General description						Orientation	NE - SW
Trench located on south facing slope. Topsoil covering colluvium. A weathered Thanet Sand recorded at the base.						Length (m)	30
						Width (m)	2
						Avg. depth (m)	0.55
Context No.	Type	Fill Of	Width (m)	Depth (m)	Description	Finds	Date
8700	Layer			0.3	Ploughsoil. Very dark greyish brown sandy silt with rounded pebbles. Friable		
8701	Layer			0.23	Colluvial Layer. Mid yellowish brown sandy silt with rare rounded pebbles. Friable.		
8702	Layer			0.2	Other Layer. Mid yellow fine sandy silt. Homogeneous and loose. Stoneless.		
8703	Layer			0.13	Other Layer. Olive fine sand with yellow mottling. Loose. Stoneless.		
8704	Void						
<b>Trench 88</b>							
General description						Orientation	N - S
Trench devoid of archaeology. Consists of topsoil, dark brownish grey silty sand Subsoil reddish brown sandy silt						Length (m)	30
						Width (m)	2
						Avg. depth (m)	1
Context No.	Type	Fill Of	Width (m)	Depth (m)	Description	Finds	Date
8800	Layer			0.32	Topsoil. Dark greyish brown sandy silt		
8801	Layer			0.18	Subsoil. Mid brown sandy silt leading to a light olive brown colour		



					towards lower boundary of context.		
8802	Void						
8803	Layer			0.6	Colluvial Layer. Mid orangey brown silty sand with common charcoal smudges		
8804	Layer			0.12	Colluvial Layer. Mid brown sandy silt		
8805	Layer			0.13	Colluvial Layer. Light mottled whiteish yellowy orange sand		
8806	Layer			0.41	Other Layer. Mid orangey bluey green mottled sandy silt		
<b>Trench 89</b>							
General description						Orientation	W/E
Trench revealed two ditches and one pit. The lowermost deposit a possible weathered/redeposited Thanet Sand covered by slopewash (possibly Holocene - prehistoric pot recorded) and stony colluvium.						Length (m)	30
						Width (m)	6
						Avg. depth (m)	2
Context No.	Type	Fill Of	Width (m)	Depth (m)	Description	Finds	Date
8900	Layer			0.3	Topsoil. Dark greyish brown sandy silt		
8901	Layer			0.24	Colluvial Layer. Mid greyish brown sandy silt	FC, Flint, Pot	MBA-MIA
8902	Layer			0.26	Colluvial Layer. Pale yellowish brown sandy silt, due to leeching	Flint, Pot	MBA-MIA
8903	Layer			0.46	Colluvial Layer. Mid orangey brown clayey silt	CBM, FC, Flint	Pmed
8904	Layer			0.2	Colluvial Layer. Mid orangey greyish brown clayey silt	Flint	
8905	Layer			0.66	Other Layer. Light orangey brown slightly clayey Thanet sand with light yellowish brown lenses.		
8906	Layer			0.5	Other Layer. Mid yellow brown sandy silt. Firm. Recorded in auger		
8907	Layer			0.45	Other Layer. Mid brown silty sand. Very rare fine pebbles.		
8908	Layer			0.15	Other Layer. Brown silty sand with common small pebbles. Not bottomed. Recorded in auger		
8909	Cut		0.7	0.12	Ditch. C/o ditch running NW-SE		
8910	Fill	8909		0.1	Secondary Fill. Light yellowish grey sandy		

					silt, friable, no inclusion visible.		
8911	Cut		0.44	0.14	Ditch. C/o ditch running NE-SW		
8912	Fill	8911		0.14	Secondary Fill. Light yellowish grey sandy silt, friable, no inclusion visible.		
8913	Cut		1	0.2	Pit. C/o pit		
8914	Fill	8913		0.2	Secondary Fill. Light greyish brown sandy silt, loose with gravel inclusion.		

<b>Trench 90</b>							
General description					Orientation	NE - SW	
Trench revealed a recut boundary ditch at the NE end. The deeper south-west end contained numerous layers of colluvium including a dark humic deposit containing CBM.					Length (m)	30	
					Width (m)	2	
					Avg. depth (m)	1.8	
Context No.	Type	Fill Of	Width (m)	Depth (m)	Description	Finds	Date
9000	Layer			0.28	Ploughsoil. Very loose dark grey brown silty clay.		
9001	Layer			0.22	Colluvial Layer. Moderately compact dark grey brown sandy silt. Common rounded pebbles.		
9002	Layer			0.09	Colluvial Layer. Mid greyish brown sandy silt. Firm. Common rounded pebbles.		
9003	Layer			0.04	Other Layer. Dark grey silt/clay. Mottled. Stoneless. Firm.	Pot	c 1270-1350?
9004	Layer			0.09	Other Layer. Dark brown humic silt. Soft. Stoneless.	C14	1750-1620 cal BC
9005	Layer			0.14	Other Layer. Black humic silt. Soft and stoneless.	Pot, CBM	c 1820-1900
9006	Layer			0.14	Other Layer. Very dark reddish brown humic silt. Stoneless and soft.		
9007	Layer			0.2	Other Layer. Light greyish brown clayey silt. Homogeneous and firm.		
9008	Layer			0.08	Other Layer. Pale olive silt. Firm and homogeneous. Stoneless.	Flint	
9009	Layer			0.26	Other Layer. Dark grey clayey silt. Firm and		

					homogeneous. Slightly mottled.		
9010	Layer			0.16	Other Layer. Light olive sandy silt with few rounded pebbles.		
9011	Layer			0.16	Colluvial Layer. Mid greyish brown sandy silt mottled with orangish brown sandy silt		
9012	Layer			0.26	Other Layer. Yellowish brown silty sand. Oxidised		
9013	Cut		1.94	0.38	Ditch. Curved linear running NE-SW angling at a 180 degree bend.		
9014	Fill	9013	1.94	0.34	Secondary Fill. Moderately compact mid blue grey silty clay, frequent moderately sized pebbles to northern edge of ditch.	Flint	
9015	Cut		0.92	0.33	Ditch. Recut of curved linear [9013].		
9016	Fill	9015	0.92	0.33	Secondary Fill. Moderately compact mid red brown silty clay, no inclusions.		
9017	Layer			0.5	Other Layer. Yellowish red mid to coarse sand with rounded pebbles. Friable.		

### Trench 91

General description					Orientation	N-S	
Trench revealed a single small pit. It comprised ploughsoil and subsoil overlying stony colluvial layers onto a humic organic deposit that was recorded in the southern end of the trench. A redeposited and oxidised sand recorded at the base. Natural geology not reached.					Length (m)	30	
					Width (m)	2	
					Avg. depth (m)	1.5	
Context No.	Type	Fill Of	Width (m)	Depth (m)	Description	Finds	Date
9100	Layer				Topsoil. Bark blackish brown sandy silt, with common rounded and sub angular pebbles		
9101	Layer				Subsoil. Mid brownish orange clayey silt, that leeches into colluvium below (9102)		
9102	Layer				Colluvial Layer. Light yellowish to white sand with small charcoal fleck inclusions	Flint	
9103	Cut		0.83	0.27	Pit. Steep sided pit, pointed base. Circular.		
9104	Fill	9103	0.2	0.11	Primary Fill. Mid yellow grey brown friable silty clay. Primary fill of		

					slumping on either side of pit		
9105	Fill	9103	0.83	0.27	Secondary Fill. Mid grey brown friable silty clay.		
9106	Cut		0.9	0.05	Natural Feature. Irregular shape, shallow cut. Mid grey brown layer, friable clay filled with small stones		
9107	Layer			0.1	Other Layer. Dark grey mottled silt/ clay. Firm. Homogeneous. Stoneless	C14	970-820 cal BC
9108	Layer			0.42	Other Layer. Black to reddish black humic silt.	C14	2140-1950 cal BC
9109	Layer			0.2	Other Layer. Mid grey silt/clay. Homogeneous and firm.	C14	3330-2920 and 3370-3100 cal BC
9110	Layer			0.65	Other Layer. Pale olive silt. Homogeneous and firm		
9111	Layer			0.4	Colluvial Layer		
9112	Layer			0.4	Other Layer. Light brown sandy silt. Friable. Homogeneous. Recorded in auger		
9113	Layer			0.3	Other Layer. Mid brown sand with flint gravel. Not bottomed. Recorded in auger		
9114	Layer			0.1	Colluvial Layer. Mottled orangey light grey sandy silt		
9115	Layer				Buried soil. Mid reddish brown silty organic layer		
9116	Layer				Colluvial Layer. Light whitish yellow silt, small sparse charcoal smudges		
9117	Layer			0.4	Other Layer. Mid brown sand silt. Homogeneous and firm.		
9118	Layer			0.5	Other Layer. Light yellow brown silty sand. Homogeneous and firm.		
9119	Layer				Buried soil. Mid reddish brown peat 0.63- 0.76m	C14	2140-1940 and 1870-1610 cal BC
9120	Layer			0.1	Buried soil. Black peat 0.76-0.90		
9121	Layer		6	0.44	Topsoil. Dark greyish brown sandy silt loam		
9122	Layer		6	0.36	Other Layer. Dark greyish brown sandy silt		
9123	Layer		6	0.16	Other Layer. Dark yellowish brown clayey silt. Possible buried soil.		
9124	Layer		2	0.36	Other Layer. Peaty layer		

9125	Layer		6	1.26	Alluvial Layer. Lenses of silt and sand alluvial material		
9126	Layer		6		Natural. Mid to light coarse sandy silt. Thanet sand.		
<b>Trench 92</b>							
General description					Orientation	NE-SW	
Trench consists of ploughsoil, subsoil and colluvial layers overlying humic peat deposit in SW end of the trench. Redeposited Thanet sand recorded at the base.					Length (m)	30	
					Width (m)	2	
					Avg. depth (m)	1.5	
Context No.	Type	Fill Of	Width (m)	Depth (m)	Description	Finds	Date
9200	Layer			0.29	Ploughsoil. Dark greyish brown silty sand.		
9201	Layer			0.3	Colluvial Layer. Mid Reddish brown clayey silt		
9202	Layer				Natural. Mid reddish yellow silty clay		
9203	Layer				Other Layer. Pale olive sandy silt. Firm. Stoneless		
9204	Layer			0.39	Colluvial Layer. Mid grey brown sandy silt. Common rounded and subrounded pebbles. Same as 9201.	Pot	c 1270-1350
9205	Layer		0.3	0.3	Other Layer. Black organic silt	Flint	
9206	Layer			0.28	Other Layer. Pale olive clayey silt. Oxidised. Not bottomed		
9207	Cut		1.04	0.56	Pit		
9208	Fill	9207	1.04	0.26	Primary Fill. Firm mid reddish brown clayey silt		
9209	Fill	9207	0.79	0.32	Deliberate Backfill. Soft dark brownish grey sandy silt	Pot	c 1250-1350?
9210	Cut		0.79	0.07	Pit		
9211	Fill	9210	0.79	0.07	Primary Fill. Firm mid greyish brown sandy silt		
9212	Cut		1.27	0.37	Ditch. NW-SE		
9213	Fill	9212	1.27	0.14	Primary Fill. Soft mid whiteish grey sandy silt	A. Bone	
9214	Fill	9212	1.27	0.14	Secondary Fill. Soft dark greyish brown sandy silt		
9215	Unexc feature		1		Pit. Intercutting pits	Flint	
9216	Layer			0.22	Other Layer. Light brown silt. Oxidised. Recorded in auger.		
9217	Layer			0.4	Other Layer. Mid yellowish brown clayey		

					silt. Possibly same as 9406. Recorded in auger		
9218	Layer			0.23	Other Layer. Mid brown silt/clay with white leaching. Recorded in auger		
9219	Layer			0.37	Other Layer. Mid brown silty sand. Stoneless. Recorded in auger		
9220	Layer			0.4	Other Layer. Mid brown sand with rare flint gravel and coarse sand. Recorded in auger		
9221	Cut		1.39	0.6	Pit. Mid yellowish brown.		
9222	Fill	9221	1.39	0.6	Primary Fill. Mid yellowish brown	Pot	c 1050-1150?
9223	Cut		0.69	0.26	Ditch. NE-SW		
9224	Fill	9223	0.69	0.26	Primary Fill. Dark brownish grey firm sandy silt		
9225	Cut		2.2	0.54	Pit		
9226	Fill	9225	1.43	0.54	Primary Fill. Dark brownish grey with frequent charcoal lenses.	Pot, FC, A. Bone	c 1100-1300?
9227	Fill	9225		0.3	Secondary Fill. mid greyish brown sandy silt.		
9228	Fill	9225	1.43	0.54	Tertiary Fill. mid reddish brown silty clay		
9229	Fill	9225	1.43	0.54	Other Fill. Firm dark sandy clay		
9230	Unexc feature		1.2		Pit. Round pit, mid grey fill seen on surface		
9231	Unexc feature		0.6		Pit. Mid grey fill, discrete		
9232	Unexc feature		0.2		Other Cut. Sub oval mid greyish brown feature adjacent to [9223]		
9233	Unexc feature		0.8		Other Cut. Mid greyish brown sub oval connected to possible linear shape		
9234	Unexc feature		1.5		Other Cut. Large pit shape attached to ditch [9221], mid grey brown fill, frequent stone inclusions		
9235	Fill		1.6		Tertiary Fill. Fill of 9230, partially excavated by machine Mid greyish brown sandy silt, moderate, mid red inclusions, possibly degraded CBM, charcoal inclusions, medium stones occ.		
9236	Fill		0.6		Secondary Fill. Fill of 9232, partially excavated		

					by machine, mid brownish grey sandy silt, moderate, charcoal inclusions freq.		
9237	Unexc feature		0.5		Ditch. E-W running linear, appears to be the same as [9306]. Mid to dark greyish brown sandy silt, freq small to mid stones. Appears to truncate 9223	Pot	c 1050-1150?
9238	Unexc feature		1.2		Pit. Small pit in N end of trench, appears to truncate [9234] charcoal rich mid greyish brown sandy silt fill	Pot	c 1100-1350
9239	Unexc feature		0.3		Pit. Small rectangular pit at far N edge of trench, only 1 quarter visible, mid grey sandy silt fill with occasional stones		
9240	Unexc feature		0.5		Other Cut. Area of redeposited natural butting larger feature Light brownish grey silty sand		
9241	Unexc feature		0.4		Pit. Small pit with red clay inclusion in centre, possibly daub Light to mid greyish brown sandy silt fill with frequent charcoal inclusions	A. Bone	
9242	Unexc feature		0.3		Pit. Small pit at far N end of trench, mid brownish grey sandy silt fill with redeposited natural and occasional stones, possibly truncated by 9234		
9243	Unexc feature		1.1		Ditch. Pit or possible ditch. Perhaps same as 9234. heavily truncated Light greyish brown sandy silt fill with frequent small stones		
9244	Fill	9225		0.12	Primary Fill. mid greyish brown sandy silt		
<b>Trench 93</b>							
General description					Orientation	N-S	
The lowermost deposit recorded in the trench is a possible a Head deposit covered by slopewash and stony colluvium. Archaeology covered by colluvium					Length (m)	30	
					Width (m)	2	
					Avg. depth (m)	1	
Context No.	Type	Fill Of	Width (m)	Depth (m)	Description	Finds	Date
9300	Layer			0.29	Topsoil. Dark greyish brown sandy silt	Pot	Roman

9301	Layer			0.2	Colluvial Layer. Mid brown sandy silt		
9302	Layer			0.16	Other Layer. Mid blackish brown sandy silt slopewash		
9303	Layer			0.38	Other Layer. Mid orangey brown with lenses of dark yellowish brown silty sand head		
9304	Cut		1	0.52	Ditch. Only identified in trench section.		
9305	Fill	9304	0.1	0.52	Secondary Fill. Mid greyish brown sandy silt, similar to colluvium (9301)		
9306	Cut		1.57	0.67	Ditch. Cut of linear ditch, runs E-W, steep sides, concave base.		
9307	Fill	9306	1.57	0.67	Secondary Fill. Mid brownish grey sandy silt, mod to compact, frequent small sub-rounded and sub angular stones. No finds, very similar to colluvium.		
9308	Unexc feature				Pit. Small pit situated below ditch 9304, mid grey brown sandy silt fill, occ. small sub rounded stone inclusions.		
9309	Cut		0.56		Pit. Cut of pit, vertical sides, irregular base, heavy bioturbation from rooting.		
9310	Fill	9309	0.56		Secondary Fill. mid brownish grey sandy silt, moderate, grass root inclusions and small sub rounded stones	Pot	c 1100-1350
9311	Unexc feature		0.26		Pit. Small pit centre of trench, directly E of 9309, mid greyish brown fill with occasional small rounded stones		
9312	Unexc feature		0.25		Pit. Small pit in centre of trench, directly S of 9309, mid greyish brown fill, occasional small rounded stones		
9313	Cut	9313	0.25	0.13	Pit. Small pit/posthole in centre of trench, 1m south of 9312. Vertical N and W sides, steep S side. rounded concave base.		
9314	Unexc feature		0.60		Pit. small pit in centre of trench against W side, directly W of 9313, mid to dark greyish brown sandy silt, occasional		



					small to mid rounded and sub angular stones.		
9315	Cut		0.78	0.07	Pit. Small circular pit in S end of trench, gradual incline of sides, irregular base.		
9316	Fill	9315	0.78	0.07	Secondary Fill. mid greyish brown, sandy silt, friable, occasional small rounded stone inclusions.		
9317	Unexc feature		5		Pit. length >1.95M, large irregularly shaped pit, wider at S end, tapers toward. Fill is mid greyish brown sandy silt, occasional medium sub angular and rounded stone inclusions. Multiple pot finds on surface, Possible Roman date.	Pot	c 1250-1350?
9318	Fill	9313	0.25	0.13	Secondary Fill. Friable mid greyish brown sandy silt, occasional small rounded stones, no finds.		

#### Trench 94

General description					Orientation	E-W	
Trench consists of ploughsoil, subsoil and colluvial layers overlying a sandy clay natural. East end contained one large pit which was excavated, in the centre another large pit which was excavated, the west end contained an excavated small midden and an unexcavated ditch.					Length (m)	30	
					Width (m)	2	
					Avg. depth (m)	0.8	
Context No.	Type	Fill Of	Width (m)	Depth (m)	Description	Finds	Date
9400	Layer			0.3	Ploughsoil. Dark greyish brown sandy silt.		
9401	Layer			0.38	Subsoil. Mid reddish brown clayey silt with gravels.		
9402	Layer				Colluvial Layer. Pale yellow to light yellowish brown silt (sandy)	Pot	c 1200-1300?
9403	Layer			0.1	Colluvial Layer. Highly compact, Light grey silty clay, very frequent moderate rounded pebbles throughout. Same as 9405 and 9408?		
9404	Cut		0.72	0.55	Pit. Irregular rounded with very steep edges, base not fully excavated. Fully excavated the base later.		

9405	Layer		0.72	0.13	Colluvial Layer. Highly compact light blue grey silty clay. Same As 9403		
9406	Fill	9404	0.72	0.15	Other Fill. Highly compact light orange brown silty clay. Probably redeposited natural.		
9407	Fill	9404	0.72	0.2	Deliberate Backfill. Moderately friable dark blackish grey silty clay.	Pot, FC, Stone	c 1200-1300?
9408	Layer			0.04	Other Layer. Pale yellow silt. Firm		
9409	Unexc feature		1.2		Ditch. Unexcavated ditch running N-S. Mid grey fill full of small to medium stones. Concreted silty clay		
9410	Cut		3.8	0.6	Pit. Steep near vertical sides, uneven concave base, truncated by rooting.		
9411	Fill	9410			Primary Fill. Slumping, redeposited natural, yellow brown sandy clay, compact		
9412	Fill	9410			Secondary Fill. Mid reddish brown sandy clay, pebble inclusions, friable	Flint	Mesolithic
9413	Fill	9410			Tertiary Fill. Light mid grey brown sandy silt, friable. Frequent Pebble inclusions	Flint	Mesolithic
9414	Layer		6		Natural. Compact mid yellow brown sandy clay, in frequent mixed pebble inclusions		
9415	Cut		2.35	0.96	Pit. Very steep, almost vertical sided cut of large pit with mostly flat base		
9416	Fill	9415	1.17	0.12	Primary Fill. Dark grey silty clay, some stones		
9417	Fill	9415	0.42	0.27	Primary Fill. Mid grey brown and yellow mottled silty clay - slumping		
9418	Fill	9415	1.41	0.36	Secondary Fill. Mid grey brown silty clay, some stones	Pot	c 1200-1300?
9419	Fill	9415	0.78	0.23	Secondary Fill. Mid grey brown silty clay occasional stones		
9420	Fill	9415	0.84	0.45	Secondary Fill. Mid brownish grey silty clay, frequent stones		
9421	Fill	9415	1.01	0.22	Secondary Fill. Mid brown grey silty clay,	Pot, FC	c 1200-1300?

					some stones and frequent burnt clay		
9422	Fill	9415	2.2	0.2	Tertiary Fill. Dark grey silty clay, frequent stones	Pot	c 1200-1300?
<b>Trench 95</b>							
General description					Orientation		E-W
Trench contains topsoil overlaying a peaty soil. A fine colluvium recorded below the peaty soil with possible buried soil in the lower sequence.					Length (m)		30
					Width (m)		2.1
					Avg. depth (m)		0.32
Context No.	Type	Fill Of	Width (m)	Depth (m)	Description	Finds	Date
9500	Layer			0.3	Ploughsoil. Very dark greyish brown sandy silt. Common rounded pebbles. Friable.	Flint	
9501	Layer			0.28	Colluvial Layer. Dark greyish brown sandy silt with rounded pebbles. Firm.		
9502	Layer			0.19	Burnt mound deposit. Black humic silt. Burnt clay and brick fragments occasional. Soft.		
9503	Layer			0.15	Buried soil. Brownish grey silt. Firm. Stoneless.		
9504	Layer			0.15	Other Layer. Grey olive clayey silt. Firm. Stoneless.		
9505	Layer			0.2	Buried soil. Dark grey clayey silt. Firm. Stoneless.	C14	10500-9880 and 8230-7840 cal BC
9506	Layer			0.15	Other Layer. Light grey clayey silt. Firm. Stoneless.		
9507	Layer			0.2	Other Layer. Light grey oxidised clayey silt. Firm. Stoneless.		
9508	Layer			0.3	Buried soil. Very dark reddish black humic silt. Soft.		
<b>Trench 96</b>							
General description					Orientation		N-S
Trench located at south facing slope. Contains layer of slopewash covered by humic / peaty soil with evidence for vegetation burning. Trench revealed ditch and pit.					Length (m)		30
					Width (m)		2
					Avg. depth (m)		1
Context No.	Type	Fill Of	Width (m)	Depth (m)	Description	Finds	Date
9600	Layer			0.24	Ploughsoil. Mid grey brown silty clay with frequent stone inclusions.		

9601	Layer			0.5	Colluvial Layer. Mid brownish grey with orange mottling silty clay with frequent small stone inclusions.		
9602	Layer			0.12	Natural. Light yellow brown silty clay, no inclusion visible.		
9603	Cut		1.33	0.26	Ditch. NE-SW linear with very steep sides leading to a shallow concave U-shaped base.		
9604	Fill	9606	1.35	0.25	Secondary Fill. Moderately compact mid blue grey silty clay.		
9605	Fill	9603	0.81	0.14	Deliberate Backfill. Moderately compact dark grey brown silty clay.	Flint	
9606	Cut		0.94	0.54	Pit. Circular/oval pit with moderate sloping sides into a concave U-shaped base.		
9607	Fill	9606	0.94	0.54	Deliberate Backfill. Highly compact mixed light reddish brown/light grey silty clay.	FC, Flint	
9608	Layer			0.2	Buried soil. Reddish brown humic silt. Soft.		
9609	Layer			0.4	Buried soil. Black humic silt. Red burnt clay and charcoal.		
9610	Layer			0.13	Other Layer. Brownish grey silt. Stoneless. Bioturbated.		
9611	Layer			0.25	Other Layer. Olive silt. Oxidised and bioturbated. Firm		
9612	Layer			0.2	Other Layer. Olive grey sandy silt. Firm and stoneless. Oxidised.		
9613	Layer			0.2	Other Layer. Grey olive sandy silt. Firm and stoneless. Calcite inclusions.		
9614	Layer		2.6	0.42	Colluvial Layer. Mid greyish brown silty clay. with some stones. Same as 9601.		

### Trench 97

General description	Orientation	N-S
The lowermost deposit recorded in the trench is a possible redeposited Thanet Sand covered by a mixed humic deposit with burnt sediments and flints. A Holocene colluvium covered the humic deposit. Flint scatter EAA excavated, with 5 spits. 2 ditches found, only 1 excavated.	Length (m)	30
	Width (m)	2
	Avg. depth (m)	1

Context No.	Type	Fill Of	Width (m)	Depth (m)	Description	Finds	Date
9700	Layer			0.22	Ploughsoil. Very dark grey brown sandy silt. Common flint pebbles. Rooting	Flint	
9701	Layer			0.13	Subsoil. Dark greyish brown sandy silt. Common rounded flint. Firm		
9702	Layer			0.26	Other Layer. Very dark greyish brown silt/clay. Mixed. Charcoal, burnt clay inclusions.		
9703	Layer			0.1	Other Layer. Pale olive silt/clay. Mottled.	Flint	Mesolithic
9704	Layer			0.19	Other Layer. Light grey silt/clay. Mottled		
9705	Layer				Other Layer. Flint scatter event.	Flint	Mesolithic
9706	Layer			0.62	Other Layer. Light brown sandy silt. Stoneless. Soft. Calcite inclusions.		
9707	Layer			0.35	Other Layer. Light brown silty sand. Soft. Stoneless. Calcite inclusions.		
9708	Layer			0.27	Other Layer. Light grey silt. Slightly sandy/ clayey. Mottled.		
9709	Unexc feature		1.3		Ditch. Unexcavated linear, same as [10720].		
9710	Cut		0.55	0.17	Voided. Natural feature		
9711	Layer			0.27	Mid to dark greyish brown sand silt. Same as 9708.	Pot	LBA?
9712	Layer			0.3	Colluvial Layer. Light grey silt. Stoneless and soft.	A. Bone	
9713	Layer			0.3	Other Layer. Mid brown clayey silt. Homogeneous and firm. Stoneless.		
9714	Layer			0.3	Other Layer. Strong brown clayey silt. Homogeneous and firm. Stoneless.		
9715	Layer			0.3	Other Layer. Light brown clayey silt with calcite inclusions. Soft.		
9716	Layer			0.3	Other Layer. Mid yellowish brown silty sand. Soft.		
9717	Layer			0.2	Other Layer. Mid brown silty sand with rare pebbles.		
9718	Layer				Natural. Yellow to olive fine sand. Stoneless. Firm		

<b>Trench 98</b>							
General description					Orientation		N-S
Trench located on the south facing slope. Trench contains a continuation of a ditch at the northern end and colluvial layers at the bottom. Contains topsoil, colluvium, peaty soil (northern part) grey silt layer with flints and oxidised slopewash.					Length (m)		30
					Width (m)		2
					Avg. depth (m)		1
Context No.	Type	Fill Of	Width (m)	Depth (m)	Description	Findings	Date
9800	Layer			0.3	Ploughsoil. Dark greyish brown sandy silt. Very rare rounded pebbles. Friable.		
9801	Layer			0.19	Colluvial Layer. Mid yellowish brown. Clayey silt Firm.		
9802	Layer			0.3	Other Layer. Pale yellowish brown. Clayey silt. Firm. Rare rounded pebbles.	Pot, Flint	c 1200-1300?
9803	Layer			0.25	Other Layer. Light grey olive silt. Compact. Very rare rounded pebbles. Same as 9809.		
9804	Layer			0.25	Buried soil. Mid brownish grey clayey silt. Reddish iron mottling. Rare rounded pebbles. Firm.		
9805	Layer			0.2	Buried soil. Black humic peaty soil recorded in the southern part of the trench.		
9806	Cut		1.4	0.37	Ditch		
9807	Fill	9806	1.4	0.37	Secondary Fill. Mid brownish grey silty clay.	Pot, Flint	c 1200-1300? Mesolithic
9808	Layer			0.12	Other Layer. Black humic silty. Burnt clay and bricks fragments occasionally. Soft.		
9809	Layer			0.28	Other Layer. Light bluish grey, silty- sand. Occasional charcoal and iron mottled.	Flint	Mesolithic ?
9810	Layer			0.3	Other Layer. Light yellowish grey, silty - sand. Occasional iron mottled and charcoal.	Flint	Neo/EBA
9811	Layer			0.18	Other Layer. Probably natural. Light grey yellow, silty-sand.	Pot	EIA
<b>Trench 99</b>							
General description					Orientation		NW-SE
					Length (m)		30

Ploughsoil and peaty soil with leached layer covering fine colluvium and a possible buried soil.					Width (m)	6	
					Avg. depth (m)	0.43	
Context No.	Type	Fill Of	Width (m)	Depth (m)	Description	Finds	Date
9900	Layer			0.4	Ploughsoil. Mid greyish brown silt.	Flint	
9901	Layer				Other Layer. Flint scatter event.	Flint, Pot	Mesolithic
9902	Layer		6	0.1	Subsoil. Firm dark greyish brown organic clay		
9903	Layer		6	0.1	Other Layer. Soft light pinkish yellow silt		
9904	Layer		6	0.05	Other Layer. Dark grey to black silt		
9905	Layer		6	0.25	Alluvial Layer. Light bluish grey silty sand		
9906	Layer		6	0.15	Other Layer. Very light yellowish brown and light bluish grey medium sand		
9907	Layer		2	0.25	Other Layer. Friable light bluish grey and light yellowish brown medium sand		
9908	Layer		2	0.6	Other Layer. Soft light greyish brown clayey silt		
9909	Layer			0.15	Alluvial Layer. Light bluish grey silty sand,		

<b>Trench 100</b>							
General description					Orientation	E-W	
Trench consists of ploughsoil overlaying colluvial layers. Trench contains two ditches and two pits.					Length (m)	30	
					Width (m)	2.1	
					Avg. depth (m)	0.49	
Context No.	Type	Fill Of	Width (m)	Depth (m)	Description	Finds	Date
10000	Layer			0.39	Ploughsoil. Dark greyish brown topsoil/ploughshares, silt with trace clay, firm, rare inclusions small stones, chalk and manganese. Boundary clear but very uneven.		
10001	Layer			0.07	Subsoil. Pale grey silt with trace clay. Soft. Very rare inclusions of chalk and charcoal, mottled with reddish yellow (Small patches) iron mineralisation, boundary clear but very uneven.	Flint	

10002	Layer				Colluvial Layer. Light pinkish grey clayey silt, moderately firm, mottled with reddish yellow small frequent patches iron mineralisation, and also small patches of pale grey silt. Some evidence for rooting/pedoturbation.		
10003	Cut		2.1	0.37	Ditch. Wide linear ditch running almost entire length of trench		
10004	Fill	10003	1.01	0.37	Secondary Fill. Dark reddish brown soft sandy silt. May be same as 10012		
10005	Cut		1.31	0.67	Ditch. Recut of ditch 10003. Linear		
10006	Fill	10005	0.5	0.24	Secondary Fill. Mid reddish brown sandy silt, soft with small sub-rounded stones.		
10007	Fill	10005	0.47	0.2	Secondary Fill. Mid grey brown soft sandy silt		
10008	Fill	10005	0.38	0.24	Secondary Fill. Light brownish yellow silty sand, friable. Possibly side collapse. Same as 10009.		
10009	Fill	10005	0.68	0.42	Secondary Fill. Light brownish yellow friable silty sand. Same as 10008		
10010	Fill	10005	1.1	0.42	Secondary Fill. Mid greyish brown soft sandy silt.		
10011	Fill	10005	0.73	0.2	Secondary Fill. Light reddish grey soft sandy silt. Final silting		
10012	Fill	10003	0.5	0.35	Secondary Fill. Dark reddish brown soft sandy silt.		
10013	Cut		0.57	0.29	Pit		
10014	Unexc feature		2.69		Pit. Unexcavated pit. Dark reddish brown clayey silt		
10015	Void						
10016	Void						
10017	Void						
10018	Fill	10013	0.57	0.29	Secondary Fill. Mid grey with mottles patches of orangish brown sandy silt, no inclusion visible.	Flint	
10019	Cut		1.9	0.46	Ditch		
10020	Fill	10019		0.46	Secondary Fill. Mid greyish brown with		



					patches of light grey and orange		
10021	Cut		0.12	0.14	Natural Feature. Possible tree throw		
10022	Fill	10021		0.14	Other Fill. Mid greyish brown sandy silt, moderate, no inclusion visible.		
<b>Trench 101</b>							
General description						Orientation	NNW-SSE
Trench contains 2 ditches and 8 pits. Trench contains gravelled natural overlain by subsoil and plousoil						Length (m)	30
						Width (m)	6
						Avg. depth (m)	0.6
Context No.	Type	Fill Of	Width (m)	Depth (m)	Description	Finds	Date
10100	Layer			0.36	Ploughsoil. Dark grey clayey silt		
10101	Layer			0.2	Subsoil. Firm light greyish brown		
10102	Layer				Natural. Mid reddish brown clayey sand		
10103	Cut		0.49	0.89	Pit		
10104	Fill	10103	0.49	0.4	Primary Fill. Dark blueish grey firm clayey silt	Pot, Fe, Flint, A. Bone	c 1050-1200?
10105	Cut		1.63	0.57	Ditch		
10106	Fill	10105	1.63	0.57	Primary Fill. Firm mixed blueish yellow clayey silt	Pot, Flint, A. Bone	c 1200-1300?
10107	Cut		2.34	1.08	Ditch		
10108	Fill	10107	2.34	0.39	Primary Fill. Firm mid brownish grey clayey silt	Pot, Fe, Flint, clay pipe, A. Bone	c 1820-1900
10109	Fill	10107	1.79	0.12	Secondary Fill. Soft dark brownish grey clayey silt		
10110	Fill	10107	1.47	0.52	Tertiary Fill. Firm mid greyish brown clayey silt	CBM, Flint, A. Bone	Pmed
10111	Cut		1.32	0.41	Pit		
10112	Fill	10111	1.32	0.41	Deliberate Backfill. Soft mid reddish brown clayey sand		
10113	Cut		1.42	0.29	Pit		
10114	Fill	10113	1.42	0.29	Primary Fill. Soft dark brownish grey clayey silt	Pot, CBM, Fe	c 1550-1800?
10115	Unexc feature		3.32		Pit. Large unexcavated pit. Mixed dark and mid brown soft sandy silt		
10116	Unexc feature		1.15		Pit. Unexcavated pit. Mid yellowish brown clayey silt		

10117	Unexc feature		1.67		Pit. Unexcavated pit. Soft dark brownish grey clayey silt		
10118	Unexc feature		1.16		Pit. Unexcavated pit. Light blueish grey soft sandy silt		
10119	Unexc feature		1.31		Pit. Unexcavated pit. Firm dark reddish brown clayey silt		
10120	Unexc feature		3.25		Pit. Large unexcavated pit. Soft dark brownish grey sandy silt		

### Trench 102

General description					Orientation	NW-SE	
Trench revealed a pair of ditches and three pits. It consisted of ploughsoil and subsoil overlying colluvial layers. The natural geology was not reached except in a 2m test pit at the NW end					Length (m)	30	
					Width (m)	6	
					Avg. depth (m)	0.36	
Context No.	Type	Fill Of	Width (m)	Depth (m)	Description	Finds	Date
10200	Layer			0.2	Ploughsoil. Dark greyish brown sandy silt. Firm. Rooting. Very rare mid pebbles.		
10201	Layer			0.1	Subsoil. Mid yellow brown sandy silt. Firm. Very rare small pebbles.		
10202	Layer			0.09	Other Layer. Mid grey silt. Yellowish mottling. Stoneless. Very rare charcoal flecks.		
10203	Layer			0.12	Colluvial Layer. Light grey brown silt, slightly clayey.	Flint	
10204	Layer			0.3	Other Layer. Mid brown silty clay. Firm and homogeneous. Very rare small pebbles.		
10205	Layer			0.12	Other Layer. Brownish white. Clayey silt. Laminated. Stoneless		
10206	Layer			0.14	Other Layer. Light yellowish brown silty sand. Cracked upper boundary filled with white clay/silt.		
10207	Layer			0.7	Natural. Mid brown sand. With coarse sand inclusions and very rare small pebbles. Not fully excavated.		
10208	Cut		0.58	0.28	Ditch		
10209	Fill	10208	0.58	0.28	Deliberate Backfill	Flint	
10210	Cut		0.48	0.22	Ditch		
10211	Fill	10210		0.22	Deliberate Backfill		
10212	Cut		0.2	0.12	Posthole. Bioturbation		

10213	Fill	10212		0.12	Secondary Fill. Light brown sandy silt. Diffuse irregular edges		
10214	Cut		0.8	0.41	Pit. Elongated oval running NE - SE. Very steep sides with concave U-shaped base.		
10215	Fill	10214	0.8	0.41	Deliberate Backfill. Friable dark blackish grey silty clay. Very frequent moderately sized charcoal and Burnt clay inclusions.	Flint	
10216	Cut		0.74	0.15	Pit. Oval put with steep Eastern side and a more sloping western edge, concave flat bottomed base.		
10217	Fill	10216	0.74	0.15	Deliberate Backfill. Firm light grey brown silty clay with frequent charcoal inclusions.		
10218	Cut			0.31	Pit. Recorded in section.		
10219	Fill	10218		0.31	Deliberate Backfill. Recorded in section.		
10220	Cut		0.61	0.21	Pit. Circular with sloping southern side, flat bottom base. Northern edge and top of pit removed by machine.		
10221	Fill	10220	0.61	0.21	Deliberate Backfill. Friable dark grey brown silty clay with frequent charcoal throughout.		

### Trench 103

General description					Orientation	NE-SW	
Trench, devoid of archaeological features. It consisted of ploughsoil and colluvial layers with a deposit containing worked flint at the southern end. A Pleistocene slopewash recorded in the lower sequence.					Length (m)	30	
					Width (m)	2	
					Avg. depth (m)	0.45	
Context No.	Type	Fill Of	Width (m)	Depth (m)	Description	Finds	Date
10300	Layer		2	0.35	Topsoil. Firm dark brownish grey clayey silt		
10301	Layer		2	0.1	Other Layer. Dark greyish brown clayey silt		
10302	Layer		2	0.2	<i>In situ</i> Burning. Mid brownish red clay silt. Dumped burnt material.		
10303	Layer		2	0.07	Buried soil. Very dark grey/blackish peaty organic silt		

10304	Layer		2	0.36	Alluvial Layer. Dark bluish grey clay silt		
10305	Layer		2	1.39	Alluvial Layer. Lenses of greyish alluvial silts and sand		
10306	Layer		2	0.32	Alluvial Layer. Gravel basal channel fill		
10307	Layer		2		Natural. Thanet Sands		
10308	Layer		2		Other Layer. Dark greyish brown and dark brownish grey sandy silt. Buried soil?		
10309	Layer		2		Colluvial Layer. Light brownish grey sandy silt. Colluvium?		
10310	Layer		2		Colluvial Layer. Light reddish brown clayey sand. Colluvial or head deposit?		
10311	Layer		2		Colluvial Layer. Light yellowish grey fine sandy silt. Leached colluvium?		
10312	Layer				Other Layer. Flint scatter event.	Flint	Mesolithic
10313	Layer			0.1	Other Layer. Brownish grey clayey silt. Firm. Stoneless.		
10314	Layer			0.1	Other Layer. Pale olive silt. Firm. Homogeneous and Stoneless.		
10315	Layer			0.13	Other Layer. Strong brown clayey silt. Layer with flints.		
10316	Layer			0.27	Other Layer. Light grey clayey silt. Oxidised. Firm. Stoneless.		
10317	Layer			0.7	Other Layer. Light grey sandy silt. Mottled. Calcite inclusions. Soft.		
10318	Layer			0.2	Other Layer. Light grey silty sand. Oxidised. Soft. Calcite inclusions.		
10319	Layer			0.2	Other Layer. Mid brown slightly sandy clayey silt. Stoneless and firm.		
10320	Layer			0.1	Other Layer. Grey olive sandy silt. Mottled. Firm. Stoneless.		
10321	Layer			0.14	Other Layer. Light brown sandy silt. Rare yellowish mottling. Firm. Calcite inclusions.		
10322	Layer			0.4	Other Layer. Mid silty sand. Soft.		
10323	Layer			0.4	Other Layer. Mid brown sandy silt. Very rare rounded pebbles.		

10324	Layer				Natural. Yellowish brown sand. Redeposited or weathered Thanet Sand?		
10325	Layer			0.07	Other Layer. Dark grey brown silty deposit visible in corner of test pit. Appears to be bioturbation, dark through mineral rather than charcoal.		
<b>Trench 104</b>							
General description						Orientation	E - W
Trench consists of ploughsoil, fine colluvium with flints and fine Pleistocene slopewash. A possible erosional gully and three test pits recorded.						Length (m)	30
						Width (m)	2
						Avg. depth (m)	0.42
Context No.	Type	Fill Of	Width (m)	Depth (m)	Description	Finds	Date
10400	Layer		2	0.33	Ploughsoil. Very loose dark grey brown silty clay.	Flint	
10401	Layer			0.11	Subsoil. Friable mid buff brown silty clay.	Flint	
10402	Layer				Other Layer. Flint scatter event.	Flint	Mesolithic
10403	Cut		0.48	0.34	Ditch. Present in flint grid ACB.		
10404	Fill	10403	0.48	0.24	Deliberate Backfill. Mid blackish grey sandy silt.	Flint	
10405	Layer			0.05	Subsoil. Remnant subsoil/ Interface with underlying deposits that survived in plan after machining.		
10406	Void						
10407	Cut		0.44	0.18	Other Cut. Gully.		
10408	Fill	10407	0.44	0.18	Primary Fill. Mid brownish grey sandy silt.		
10409	Layer			0.15	Colluvial Layer. 0.35-0.4m. Pale brown slightly clayey silt, very fine. Soft. Mottled with mid reddish yellow iron mineralisation (Small but frequent patches) likely indicating changing water levels over time. Changes to mid grey somewhere between 6-15m from NW extent of trench.		
10410	Layer			0.44	Colluvial Layer. Mid brown slightly sandy clayey silt. Firm.		

10411	Fill	10403	0.3	0.08	Primary Fill. Mid brownish grey sandy silt.		
10412	Fill	10403	0.28	0.28	Deliberate Backfill. Mod reddish grey- Light yellowish grey sandy silt.		
10413	Layer				Other Layer. Pale brownish grey silt. Common pebbles. Irregular in shape. Possibly a erosional feature filled with colluvium.		
10414	Void						

### Trench 105

General description					Orientation	E - W	
Trench devoid of archaeology. Trench consists of ploughsoil and fine colluvium with worked flints.					Length (m)	30	
					Width (m)	2	
					Avg. depth (m)	0.71	
Context No.	Type	Fill Of	Width (m)	Depth (m)	Description	Finds	Date
10500	Layer			0.26	Ploughsoil. Very loose dark grey brown silty clay.		
10501	Layer			0.1	Subsoil. Mid greyish brown sandy silt. Firm.		
10502	Layer			0.15	Other Layer. Highly compact light grey sandy silt. Pale yellowish mottling.		
10503	Layer				Other Layer. Flint scatter event.	Flint, Pipe	Mesolithic C17th
10504	Layer			0.1	Colluvial Layer. Light yellowish brown clayey silt.		
10505	Layer			0.22	Natural. Mid brownish yellow silty clay, compact.		

### Trench 106

General description					Orientation	N-S	
Trench consists of ploughsoil covering colluvial layers. A possible stabilisation layer recorded below colluvium. Pleistocene slopewash recorded at the base. Excavated to a depth of 2m.					Length (m)	30	
					Width (m)	6	
					Avg. depth (m)	0.6	
Context No.	Type	Fill Of	Width (m)	Depth (m)	Description	Finds	Date
10600	Layer			0.3	Ploughsoil. Very greyish brownish grey sandy silt with rounded pebbles.		
10601	Layer			0.24	Colluvial Layer. Mid yellowish brown sandy silt with rare rounded pebbles. Firm.		

10602	Layer			0.43	Colluvial Layer. Strong brown clayey silt with very rare rounded pebbles. Firm.		
10603	Layer			0.35	Colluvial Layer. Strong brown sandy silt. Homogeneous and firm. Stoneless.		
10604	Layer			0.22	Buried soil. Mid brown silt. Homogeneous and firm. Rare manganese staining. Stoneless.		
10605	Layer			0.48	Other Layer. Pale brown silt with white calcite inclusions. Stoneless and firm.		

### Trench 107

General description		Orientation	NE-SW
Trench located at south facing slope. 3 pits, two ditches and posthole excavated, archaeology section numbers 10705-10708. Topsoil covering Holocene colluvium was recorded. A possible buried soil was sealed by colluvium. Oxidised slopewash layers and sandy gravel (Head deposit) recorded at the base of the sequence.		Length (m)	30
		Width (m)	6
		Avg. depth (m)	0.8

Context No.	Type	Fill Of	Width (m)	Depth (m)	Description	Finds	Date
10700	Cut		0.83	0.25	Pit. Sub oval pit, steep concave sides, rounded base.		
10701	Fill	10700	0.83	0.09	Primary Fill. Slumping, light yellowish brown sandy silt with occasional dark black streaks, no inclusions.		
10702	Fill	10700	0.7	0.15	Secondary Fill. Dark black sandy silt, friable, occasional flints.	Flint	
10703	Cut		0.32	0.12	Pit. Recut of pit vertical N side, moderate incline on S side, rounded concave base.		
10704	Fill	10703	0.32	0.12	Deliberate Backfill. Backfill, mid yellowish brown sandy silt, friable.		
10705	Layer				Other Layer. Flint scatter event.	Flint	Mesolithic
10706	Layer			0.3	Ploughsoil. Mid greyish brown		
10707	Layer			0.26	Colluvial Layer. Mid greyish brown sandy silt with rare rounded pebbles. Firm.	Flint	
10708	Layer				Other Layer. Light grey/olive silt. Firm. Oxidised.	Flint, Pot	Mesolithic E. Roman
10709	Layer			0.37	Other Layer. Mid yellowish red slightly	Flint	Mesolithic

					clayey silt. Firm and stoneless.		
10710	Layer			0.12	Buried soil. Mid brown silt. Very rare rounded pebbles. Firm		
10711	Layer			0.12	Buried soil. Brownish grey clayey silt. Firm.		
10712	Layer				Colluvial Layer. Light grey silty. Yellowish mottling. Firm.		
10713	Layer			0.6	Other Layer. Mid grey, oxidised clayey silt. Firm and stoneless.		
10714	Layer			0.18	Other Layer. Mid grey oxidised sandy silt. Soft. Stoneless.		
10715	Layer			0.08	Other Layer. Reddish brown coarse sand silt with abundant rounded pebbles. Loose.		
10716	Layer			0.3	Other Layer. Light grey slightly sandy silt. Oxidised. Stoneless.		
10717	Layer			0.13	Other Layer. Mid grey sandy silt. Oxidised. Firm. Stoneless.		
10718	Cut				Ditch. E-W linear with gradually sloping sides into concave U-shaped base.		
10719	Fill	10718			Secondary Fill. Moderately compact mid brown grey silty clay.		
10720	Cut				Ditch. E-W linear, steep sided with concave U-shaped base.		
10721	Fill	10720			Deliberate Backfill. Highly friable mid buff brown silty clay.		
10722	Fill	10723	0.52	0.91	Deliberate backfill. Moderately compact light grey sandy clay, rare orangey streaks throughout.	Flint	Mesolithic
10723	Cut		0.52	0.91	Posthole. Circular, near vertical sides, concave U-shaped base.		
10724	Fill	10723	0.22	0.49	Post-pipe. Extremely friable very dark reddish black silty sand.		
10725	Cut		0.9	0.22	Pit. Irregular circular pit, very steep sides, concave flat bottomed base.		
10726	Fill	10725	1	0.4	Deliberate Backfill. Moderately compact light blue grey silty clay.		



10727	Fill	10725	1	0.45	Secondary Fill. Moderately friable light grey brown silty clay.		
10728	Fill	10723	0.22	0.61	Other Fill. Moderately friable light grey brown silty clay.		
10729	Unexc feature		1	1.5	Ditch. Terminus of linear ditch running NW-SE.		
10730	Layer				Natural. Highly compact light orange brown silty clay.		
10731	Cut		0.63	0.21	Pit. Or Tree throw		
10732	Fill	10731		0.21	Secondary Fill. Dark charcoal rich silt		
10733	Layer			0.2	Other Layer. Mid brown clayey silt. Homogeneous and firm.		
10734	Layer			0.6	Other Layer. Mid brown sandy silt with very rare rounded pebbles. Firm.		
10735	Layer			0.12	Other Layer. Dark brown mid sand with rounded pebbles. Soft.		
10736	Fill	10720		0.26	Secondary Fill. Dark grey silty clay		
10737	Fill	10731		0.15	Primary Fill. Light grey sandy silt.		

#### Trench 108

General description					Orientation		
					Length (m)		
					Width (m)		
					Avg. depth (m)		
Context No.	Type	Fill Of	Width (m)	Depth (m)	Description	Finds	Date

#### Trench 109

General description					Orientation		E-W
Flints present. Tree bole located at the eastern end of the trench, excavated and sampled. Trench contains topsoil over a possible remnant of peaty soil and Pleistocene slopewash in the lower section.					Length (m)		30
					Width (m)		2.1
					Avg. depth (m)		0.3
Context No.	Type	Fill Of	Width (m)	Depth (m)	Description	Finds	Date
10900	Layer		2.1	0.3	Ploughsoil. Mid grey brown, silty clay, friable	Flint	
10901	Layer				Other Layer. Flint scatter event.	Flint	Mesolithic
10902	Layer		6	0.2	Other Layer. Soft to friable light brownish yellow sandy silt. Bleached brickearth horizon?	Flint	Mesolithic
10903	Layer		6	0.35	Other Layer. Soft light brownish grey clayey sandy silt. Early		

					Holocene slope deposits?		
10904	Layer		2	0.45	Other Layer. Soft to friable light brownish grey and light yellowish brown silty sand.	Flint	Mesolithic
10905	Layer		2	0.55	Other Layer. Soft to friable light brownish yellow and mid brownish red medium silty sand. Pleistocene slope deposit?		
10906	Layer		2	0.1	Other Layer. Soft light greyish brown fine silty sand. Pleistocene slope deposit?		
10907	Cut		2.09	0.53	Pit		
10908	Fill	10907	2.09	0.53	Primary Fill. Mid brown greyish sandy silt.	Flint, pot	LBA-EIA
10909	Layer			0.2	Subsoil. Light greyish brown sandy clayey silt.		

<b>Trench 110</b>							
General description					Orientation		N-S
Trench devoid of archaeology. Trench consists of topsoil dark brown grey silty sand Subsoil brownish red Sandy silt					Length (m)		30
					Width (m)		2
					Avg. depth (m)		0.36
Context No.	Type	Fill Of	Width (m)	Depth (m)	Description	Finds	Date
11000	Layer				Ploughsoil. Dark grey sandy silt		
11001	Layer		2.1		Colluvial Layer. Light-med yellowish brown, sandy silt. Common inclusions of small stones (rounded and angular) 1-4cm diameter. Moderate compaction. Some flint present, possibly burnt (white). Boundary very diffuse, only really apparent by feel rather than visually. Rooting throughout.		
11002	Layer				Other Layer. Light-med yellowish brown, clayey silt with very fine sand. Firm (like cutting through cheddar with a plastic spoon). Very rare inclusions, small stones up to 2cm diameter. Minimal rooting. Boundary very diffuse - by feel only.		

11003	Layer				Other Layer. Light yellowish brown clayey silt. Firm. Stoneless		
11004	Layer				Other Layer. Pale brown sandy silt. Calcite inclusions. Soft. Stoneless.		
<b>Trench 111</b>							
General description					Orientation	E-W	
Trench devoid of archaeology. Consists of topsoil dark brown silty sand and subsoil overlying a colluvial layer. Pleistocene geology not exposed at the 1m depth. Followed by colluvial layer mixed with gravel					Length (m)	30	
					Width (m)	2	
					Avg. depth (m)	1	
Context No.	Type	Fill Of	Width (m)	Depth (m)	Description	Finds	Date
11100	Layer			0.3	Ploughsoil. Grey brown sandy silt		
11101	Layer			0.2	Subsoil. Mid reddish brown, sandy silt		
11102	Layer			0.5	Colluvial Layer. reddish brown silty sand		
<b>Trench 112</b>							
General description					Orientation	NW-SE	
Trench devoid of archaeology. Consists of topsoil dark brownish grey silty sand Subsoil reddish brown sandy silt					Length (m)	30	
					Width (m)	2	
					Avg. depth (m)	0.41	
Context No.	Type	Fill Of	Width (m)	Depth (m)	Description	Finds	Date
11200	Layer				Topsoil		
11201	Layer			0.2	Colluvial Layer. Mid greyish brown sandy silt with rounded pebbles. Friable.		
11202	Layer			0.36	Colluvial Layer. Strong brown clayey silt. Firm and homogeneous. Stoneless.		
11203	Layer			0.17	Colluvial Layer. Light-med yellowish brown, clayey silt. No inclusions, rooting throughout.		
11204	Layer				Alluvial Layer. Light greyish brown sandy silt. Stoneless. Firm.		
<b>Trench 113</b>							
General description					Orientation	NE-SW	
Trench devoid of archaeology. Trench consisted of ploughsoil and two layers of colluvium over palaeosol and earlier colluvium. Natural Pleistocene material in base of trench					Length (m)	30	
					Width (m)	6	
					Avg. depth (m)	1	
Context No.	Type	Fill Of	Width (m)	Depth (m)	Description	Finds	Date

11300	Layer		6	0.33	Ploughsoil. Friable dark greyish brown sandy silt		
11301	Layer		6	0.27	Colluvial Layer. Soft to friable dark yellowish brown clayey sandy silt		
11302	Layer		6	0.35	Colluvial Layer. Soft to friable mid yellowish brown clayey silt	Flint	Mesolithic?
11303	Layer		6	0.35	Buried soil. Soft light yellowish brown clayey silt	Flint, Pot	Mesolithic MBA-MIA
11304	Layer		6	0.4	Colluvial Layer. Soft light brownish grey and light reddish yellow clayey silt		
11305	Layer		6	0.4	Natural. Soft light greyish brown clayey silt		
11306	Layer			0.5	Other Layer. Strong brown clay silt. Stoneless. Homogeneous and firm.		
11307	Layer			0.2	Other Layer. Strong brown silty sand with rounded pebbles. Soft.		

#### Trench 114

General description					Orientation		
					Length (m)		
					Width (m)		
					Avg. depth (m)		
Context No.	Type	Fill Of	Width (m)	Depth (m)	Description	Finds	Date

#### Trench 115

General description					Orientation		NW-SE
Trench devoid of archaeology. Trench consists of topsoil over lays colluvium and a possible Pleistocene slopewash. No archaeology found					Length (m)		30
					Width (m)		5.5
					Avg. depth (m)		2

Context No.	Type	Fill Of	Width (m)	Depth (m)	Description	Finds	Date
11500	Layer			0.26	Ploughsoil. Dark greyish brown sandy silt. Common rounded pebbles. Friable		
11501	Layer			0.14	Colluvial Layer. Mid greyish brown sandy silt. friable. Common rounded pebbles.		
11502	Layer			0.25	Colluvial Layer. Mid yellowish brown sandy silt. Firm. Common rounded pebbles.		
11503	Layer			0.25	Colluvial Layer. Mid yellowish brown sandy silt. Common rounded pebbles. Firm.		

11504	Layer			0.54	Other Layer. Strong brown clayey silt. Firm and homogeneous. Stoneless.		
11505	Layer			0.14	Other Layer. Strong brown clayey silt. Firm and homogeneous. Stoneless.		
11506	Layer			0.4	Other Layer. Pale yellowish brown silt. Firm. Stoneless.		
11507	Layer			0.35	Other Layer. Yellowish grey mottled silt. Soft. Stoneless		
11508	Layer			0.17	Other Layer. Dark yellow brown silty sand. Mottled. Stoneless		
11509	Layer			0.05	Other Layer. Light yellow brown clayey silt. Friable. Stoneless		
11510	Layer			0.3	Other Layer. Mid greyish brown clay silt. Rare rounded pebbles. friable		
11511	Layer			0.14	Other Layer. Mid orange brown clayey sand. Friable.		
11512	Layer			0.08	Other Layer. Light yellow brown silty sand. Friable Few subangular pebbles. Not fully excavated.		
11513	Layer			0.1	Colluvial Layer. Mid yellow brown sandy silt. Firm and homogeneous. Stoneless		

### Trench 116

General description	Orientation	NE-SW
Trench devoid of archaeology. Topsoil and colluvium sit on sandy natural.	Length (m)	30
	Width (m)	5.5
	Avg. depth (m)	1

Context No.	Type	Fill Of	Width (m)	Depth (m)	Description	Findings	Date
11600	Layer			0.32	Topsoil. Very dark greyish brown sandy silt. Rare rounded pebbles. Rooting		
11601	Layer			0.4	Colluvial Layer. Mid yellowish brown sandy silt common rounded pebbles. Firm.	CBM	Roman?
11602	Layer			0.2	Colluvial Layer. Mid yellowish brown clayey silt. Homogeneous and firm. Stoneless	Pot	
11603	Layer			0.31	Colluvial Layer. Mid brown clayey silt. Firm		

					and homogeneous. Stoneless.		
11604	Layer			0.42	Colluvial Layer. Mid brown yellow. Silt. Homogeneous and firm. Stoneless.		
11605	Layer			0.2	Other Layer. Mid grey with yellow mottling. Silt. Firm.		
11606	Layer			0.28	Natural. Mid greyish brown silty clay. Pleistocene Slopewash?.		

### Trench 117

General description					Orientation	N-S	
Trench contains no visible archaeology. Topsoil and stony colluvium cover a silty colluvium at the base					Length (m)	30	
					Width (m)	2.1	
					Avg. depth (m)	0.8	
Context No.	Type	Fill Of	Width (m)	Depth (m)	Description	Finds	Date
11700	Layer			0.35	Topsoil. Dark greyish brown sandy silt with rounded pebbles. Friable		
11701	Layer			0.28	Colluvial Layer. Mid yellowish brown sandy silt with common pebbles.		
11702	Layer			0.2	Colluvial Layer. Mid yellowish brown sandy silt. Rare pebbles. Firm.		
11703	Layer			0.17	Colluvial Layer. Mid yellowish brown silt. Very rare pebbles. Firm.		

### Trench 118

General description					Orientation	NE SW	
Trench devoid of archaeology. Consists of topsoil covers a greyish brown sandy silt colluvium and strong brown clayey silt colluvium.					Length (m)	30	
					Width (m)	2	
					Avg. depth (m)	1	
Context No.	Type	Fill Of	Width (m)	Depth (m)	Description	Finds	Date
11800	Layer			0.3	Topsoil. Dark greyish brown sandy silt with rounded pebbles. Rooting. Friable.		
11801	Layer			0.3	Colluvial Layer. Mid greyish brown sandy silt with rounded pebbles. Firm.		
11802	Layer			0.12	Colluvial Layer. Yellowish brown sandy silt. Firm.		
11803	Layer			0.26	Colluvial Layer. Strong brown clayey silt.		

					Homogeneous and firm. Stoneless.		
<b>Trench 120</b>							
General description					Orientation	NE-SW	
Trench contains one ditch. It was located on the south facing slope and consisted of ploughsoil overlaying colluvium and redeposited Thanet Sand.					Length (m)	30	
					Width (m)	6	
					Avg. depth (m)	0.6	
Context No.	Type	Fill Of	Width (m)	Depth (m)	Description	Finds	Date
12000	Layer			0.31	Ploughsoil. Very dark greyish brown sandy silt. Firm. Common rounded pebbles.		
12001	Layer			0.22	Colluvial Layer. Mid greyish brown sandy silt. Firm. Common rounded pebbles.		
12002	Layer			0.16	Colluvial Layer. Mid greyish brown. Firm sandy silt. Very rare rounded pebbles.		
12003	Layer			0.58	Other Layer. Strong brown clayey silt. Firm and homogeneous. Stoneless		
12004	Layer			0.15	Other Layer. Strong brown clayey silt. Firm. Common manganese oxides.		
12005	Layer			0.39	Other Layer. Yellow brown silty sand. Friable.		
12006	Layer			0.14	Other Layer. Light grey silty sand. Mottled		
12007	Cut		1	0.35	Ditch. C/o ditch		
12008	Fill	12007		0.35	Secondary Fill. Mid brown ditch fill	Flint	
<b>Trench 121</b>							
General description					Orientation	SW-NE	
Trench devoid of archaeology. Consisted of ploughsoil overlying Subsoil and colluvium.					Length (m)	30	
					Width (m)	2	
					Avg. depth (m)	0.6	
Context No.	Type	Fill Of	Width (m)	Depth (m)	Description	Finds	Date
12100	Layer			0.32	Ploughsoil. Dark greyish brown sandy silt		
12101	Layer			0.27	Other Layer. Mid reddish brown clayey silt		
12102	Layer			0.36	Other Layer. Light yellowish slightly clayey silt		
<b>Trench 122</b>							

General description						Orientation	N-S
Trench devoid of archaeology. Trench consisting of ploughsoil, subsoil and colluvium overlying the natural geology.						Length (m)	30
						Width (m)	2
						Avg. depth (m)	1
Context No.	Type	Fill Of	Width (m)	Depth (m)	Description	Finds	Date
12200	Layer		2	0.25	Ploughsoil. Friable mid brownish grey sandy silt		
12201	Layer		2	0.3	Subsoil. Friable light greyish brown sandy silt		
12202	Layer		2	0.25	Colluvial Layer. Soft light brownish grey and light brownish red clayey silt		
12203	Layer		2		Natural. Soft to friable light brownish grey and light yellowish brown fine sandy silt		
12204	Layer		2	0.4	Natural. Firm to stiff mid brownish red silty clay. Head deposit.		
12205	Layer		2		Natural. Friable light greyish green fine sand. Thanet sand		
12206	Layer			0.81	Other Layer. Light greyish green fine sand with frequent reddish brown mottling.		
12207	Layer			0.33	Other Layer. Mid yellowish brown silty sand		
12208	Layer			0.21	Other Layer. Mid greyish yellowy brown silty sand mottled with small mid reddish oxidised specks		
12209	Layer			0.75	Other Layer. Mid orangey yellow silty sand with oxidised specks of sediment		
12210	Layer				Other Layer. Mid greyish brown silty sand. At 2.95m visible, however depth unknown due to auger stopped at this depth.		
<b>Trench 123</b>							
General description						Orientation	N-S
Trench devoid of archaeology. Trench consisting of ploughsoil, subsoil and colluvium overlying the natural. OSL sample						Length (m)	30
						Width (m)	2
						Avg. depth (m)	1
Context No.	Type	Fill Of	Width (m)	Depth (m)	Description	Finds	Date
12300	Layer		2	0.35	Topsoil. Friable mid brownish grey sandy silt		
12301	Layer		2	0.25	Subsoil. Friable mid reddish brown sandy silt		



12302	Layer		2	0.2	Colluvial Layer. Friable mid brownish grey silty sand	Flint	
12303	Layer		2	0.25	Buried soil. Soft mid greyish brown sandy silt		
12304	Layer		2		Natural. Mixed light brownish red sandy clay and light yellowish brown medium sand		

### Trench 125

General description		Orientation	NE- SW
Trench devoid of archaeology. Consists of ploughsoil overlying colluvium and a possible weathered/ redeposited Thanet Sand recorded at the base.		Length (m)	30
		Width (m)	2
		Avg. depth (m)	1

Context No.	Type	Fill Of	Width (m)	Depth (m)	Description	Finds	Date
12500	Layer			0.34	Ploughsoil. Dark greyish brown sandy silt with occasional rounded pebbles. Rooting. Friable	Flint	
12501	Layer			0.26	Colluvial Layer. Mid greyish brown sandy silt with rare rounded pebbles. Firm		
12502	Layer			0.25	Colluvial Layer. Mid yellowish brown sandy silt. Very rare rounded pebbles. Firm	Pot	MBA-MIA
12503	Layer			0.31	Colluvial Layer. Strong brown clayey silt. Homogeneous and firm. Stoneless.		
12504	Layer			0.4	Other Layer. Light grey silty sand. Oxidised. Calcite accumulation throughout.		
12505	Layer			0.25	Other Layer. Light grey silty sand. Oxidised.		
12506	Layer			0.44	Other Layer. Mid yellowish brown sandy silt. Very rare small pebbles. Firm.		
12507	Layer			0.16	Other Layer. Pale brown sandy silt with rare calcite accumulation. Firm.		
12508	Layer			0.36	Other Layer. Pale brown silt. Firm. Very rare small pebbles.		
12509	Layer			0.15	Other Layer. Pale olive sandy silt. Oxidised. Soft		

### Trench 126

General description		Orientation	NNW-SSE
		Length (m)	30

Trench revealed a small tree throw hole containing worked flint flakes. This was overlain by colluvium, subsoil and ploughsoil.						Width (m)	2.2
						Avg. depth (m)	0.85
Context No.	Type	Fill Of	Width (m)	Depth (m)	Description	Finds	Date
12600	Layer			0.26	Topsoil. Dark grey brown sandy and with rounded pebbles.		
12601	Layer			0.4	Colluvial Layer. Mid greyish brown sandy silt with occasional rounded pebbles. Firm		
12602	Layer			0.28	Colluvial Layer. Mid brown clayey silt. Homogeneous and firm. Stoneless		
12603	Layer			0.1	Colluvial Layer. Strong brown clayey silt. Homogeneous and firm. Stoneless.		
12604	Cut		0.33	0.07	Pit. Irregular base, steep sides, sub rectangular pit with additional rounded rectangular protrusions in top profile.		
12605	Fill	12604	0.33	0.07	Secondary Fill. Friable dark blackish brown sandy silt with frequent shattered flint inclusions around 1-2 cubic centimetres.		

### Trench 127

General description						Orientation	N-S
Trench consisting of ploughsoil covering colluvium. Suspected pit or tree bole investigated. The lowermost sequence consists of gravel and laminated sand. Geoarch section 12700 and 12701 recorded. Trench revealed an elongated pit or tree bole NW-SE aligned, cutting natural (12704), showing an <i>in situ</i> burning activity.						Length (m)	30
						Width (m)	2
						Avg. depth (m)	1
Context No.	Type	Fill Of	Width (m)	Depth (m)	Description	Finds	Date
12700	Layer			0.3	Topsoil. Dark greyish brown sandy silt		
12701	Layer			0.16	Colluvial Layer. Mid greyish brown sandy silt		
12702	Layer			0.22	Other Layer. Mid yellowish brown silty sand		
12703	Layer			0.45	Other Layer. Dark yellowish orangey laminated silty sand		
12704	Layer			0.76	Natural. Light yellowish brown sand with frequent lamination bands of oxidisation or dark yellowish brown sand.		
12705	Layer			0.1	Other Layer. Reddish brown silty clay.		

12706	Cut		1.78	0.5	Pit. Cut of elongated oval pit or tree bole showing evidences of <i>in situ</i> burning activity. the lower fill (12707) contains very frequent burnt stones. Occ small roots were found throughout the feature.		
12707	Fill	12706	1.1	0.2	Other Fill. Dark bluish black, silty-sand, friable. Very frequent small burnt stones and charcoal flecks incl.		
12708	Fill	12706	1.1	0.2	Other Fill. Mid grey brown, silty-sand, friable		
12709	Fill	12706	1.1	0.1	Other Fill. Mid brownish red, silty-sand, friable.		
12710	Fill	12706		0.2	Secondary Fill. Light yellowish brown, sand.		
12711	Fill	12706	1.1	0.3	Other Fill. Mid grey brown, silty sand with a lens of charcoal. Occ. small stones		
12712	Fill	12706		0.08	Deliberate Backfill. Charcoal rich deposit.		

### Trench 129

General description						Orientation	E-W
Trench situated on South facing slope. Trench devoid of archaeology. Trench consists of topsoil, dark brownish grey silty sand covering colluvium layers. A possible weathered Thanet Sand recorded at the base.						Length (m)	30
						Width (m)	6
						Avg. depth (m)	1
Context No.	Type	Fill Of	Width (m)	Depth (m)	Description	Finds	Date
12900	Layer			0.33	Ploughsoil. Dark greyish brown sandy silt. Friable.		
12901	Layer			0.19	Colluvial Layer. Mid greyish brown sandy silt. Occasional rounded pebbles. Firm.		
12902	Layer			0.2	Colluvial Layer. Mid greyish brown sandy silt. Firm.	Flint	
12903	Layer			0.34	Colluvial Layer. Strong brown clayey silt. Firm.		
12904	Layer			0.2	Other Layer. Grey silty sand. Mottled. Soft		

### Trench 132

General description						Orientation	E-W
Trench located on S/W facing slope. Trench devoid of archaeology and consists of topsoil covering Holocene colluvium. The lower sediments consists of a reddish Head						Length (m)	30
						Width (m)	2
						Avg. depth (m)	1

deposit with pebbles. A possible <i>in situ</i> solid bedrock recorded at the base.							
Context No.	Type	Fill Of	Width (m)	Depth (m)	Description	Finds	Date
13200	Layer			0.3	Ploughsoil. Dark greyish brown sandy silt with rounded pebbles. Friable.		
13201	Layer			0.15	Colluvial Layer. Mid greyish brown sandy silt with rounded pebbles. Firm.		
13202	Layer			0.24	Colluvial Layer. Mid yellowish brown slightly silty sand. Soft.		
13203	Layer			0.31	Colluvial Layer. Mid reddish brown sandy clay/silt. Compact.		
13204	Layer			0.13	Other Layer. Mid reddish brown silty sand. Compact.		
13205	Layer			0.24	Other Layer. Mid yellowish red silty sand. Rare pebbles. Soft.		
13206	Layer			0.27	Other Layer. Dark yellowish red sand. Iron pans present. Compact.		
13207	Layer			0.2	Other Layer. Yellow sand. Soft.		
13208	Layer			0.26	Natural. Pale yellow sand. Reddish iron pans throughout. Soft.		

### Trench 133

General description					Orientation	N-S	
Trench devoid of archaeology. Consists of topsoil brownish grey Sandy silt Subsoil medium reddish brown clayey silt					Length (m)	30	
					Width (m)	2	
					Avg. depth (m)	1.5	
Context No.	Type	Fill Of	Width (m)	Depth (m)	Description	Finds	Date
13300	Layer			0.32	Ploughsoil. Mid greyish brown slightly clayey silt		
13301	Layer			0.24	Colluvial Layer. Dark yellowish brown slightly clayey silt		
13302	Layer			0.33	Other Layer. Mid yellowish brown silty clay		
13303	Layer			0.12	Colluvial Layer. Light/pale yellowish brown with mottled patches of light greenish brown clayey silt		
13304	Layer			0.11	Other Layer. Mid yellowish brown sandy silt		
13305	Layer			0.18	Other Layer. Dark brownish yellow firm silty sand. Rare rounded pebbles.		

13306	Layer			0.55	Other Layer. Reddish brown coarse sand. Abundant rounded pebbles.		
13307	Layer			0.4	Other Layer. Mid grey oxidised clay. Band of coarse sand.		
13308	Layer			0.18	Other Layer. Strong brown coarse sand.		
13309	Layer			0.24	Other Layer. Reddish brown coarse sand. Abundant, moderately sorted rounded pebbles.		
13310	Layer			0.24	Other Layer. Yellow coarse sand. Dark red and yellow lamination-oxidation. Not fully excavated.		

### Trench 137

General description					Orientation		N-S
Trench devoid of archaeology. Topsoil overlying 2 colluvium, a thin head deposit occasionally cut by organic context below. Thanet sand with mixed organic context from above.					Length (m)		30
					Width (m)		2
					Avg. depth (m)		0.85
Context No.	Type	Fill Of	Width (m)	Depth (m)	Description	Finds	Date
13700	Layer			0.28	Ploughsoil. Dark greyish yellowish brown slightly clayey silt		
13701	Layer			0.15	Colluvial Layer. Light yellowish brown mottled with mid yellowish brown slightly sandy silt		
13702	Layer			0.33	Colluvial Layer. Pale yellowish brown mottled with a light yellowish brown. Slightly clayey silt		
13703	Layer			0.04	Other Layer. Pale greyish mottled with mid yellowish brown sandy silt. Thin Head deposit		
13704	Layer			0.06	Other Layer. Dark blackish brown slightly clayey sand. Organic deposit that is also mixed within the natural Thanet sand		
13705	Layer			0.07	Natural. Thanet sand. Light olive mottled with mid yellowish brown. Sand. Mixed within context if organic sediment (13704)		

### Trench 138

General description					Orientation		N-S
					Length (m)		30

Trench revealed 1 small pit, 1 tree throw within a deposit and 2 burnt/charcoal rich pits. A large quantity of flints towards N end of trench Consists of topsoil and sub soil (may be the same, top soil undergone bleaching?) 2 colluviums overlying a thin head deposit. Thanet sand at base.						Width (m)	2.1
						Avg. depth (m)	0.22
Context No.	Type	Fill Of	Width (m)	Depth (m)	Description	Finds	Date
13800	Layer		2.1	0.22	Ploughsoil. Pale greyish brown silt	Flint	
13801	Layer		2.1	0.12	Subsoil. Mid greyish brown slightly clayey silt		
13802	Layer		2.1	0.23	Colluvial Layer. Pale greyish yellow mottled with light yellowish brown. Slightly clayey silt with common manganese flecks		
13803	Layer			0.28	Colluvial Layer. Pale yellowish brown mottled with mid yellowish brown. Slightly clayey silt		
13804	Layer			0.08	Other Layer. Mid yellowish brown mottled with light grey. Silty sand. Possible head deposit?		
13805	Layer			0.2	Natural. Mid yellowish brown mottled with mid reddish brown. Slightly Silty sand. Thanet sand?		
13806	Cut		0.42	0.08	Pit. Shallow concave base with gentle to moderate sloping sides. Top profile is flat.		
13807	Fill	13806	0.42	0.08	Other Fill. Friable light grey brown silty clay. <5% charcoal and heat affected flint inclusions. No dateable evidence recovered. Sample taken.		
13808	Cut		1	0.33	Pit		
13809	Fill	13808	1	0.34	Other Fill. Dark grey black, clayey silt. Burnt pit containing high concentration of fire cracked flint.	FC, Flint	
13810	Cut		1.22	0.36	Natural Feature. Irregular deposit with steep to moderate sloping sides, slightly stepped towards NE.		
13811	Fill	13810	1.22	0.36	Other Fill. Friable mottled light yellow and light red brown silty clay/sandy silt. 5% flint	Flint	Mesolithic

					and <5% charcoal. Significant amount of flint recovered.		
13812	Layer				Colluvial Layer. Friable light red brown silty clay/sandy silt. Is not present in Geo section 13800. Probably same as 13804		
13813	Cut		0.9	0.23	Pit		
13814	Fill	13813	0.9	0.23	Primary Fill. Medium grey blue clayey silt with occasional subangular stone inclusions.	Flint, Pot	MBA-MIA

### Trench 139

General description					Orientation		N-S
Trench has revealed a concentration of flints at the northern end, a small pit close to the mid of trench, a very thin gully in E-W direction (also at the mid of the trench), and a tree throw at the southern end with a high concentration of flints. Consists of ploughsoil and subsoil overlying colluvial layers and natural geology of sandy clay.					Length (m)		30
					Width (m)		2.1
					Avg. depth (m)		0.5
Context No.	Type	Fill Of	Width (m)	Depth (m)	Description	Finds	Date
13900	Layer			0.34	Ploughsoil. Mid greyish brown slightly clayey silt	Flint	
13901	Layer			0.26	Colluvial Layer. Light yellowish brown mottled with a mid yellowish brown. Occasional light grey mottling in lower part of context. Slightly clayey silt.	Flint	
13902	Layer			0.14	Colluvial Layer. Mid yellowish brown mottled with light grey. Clayey silt.	Flint	
13903	Layer				Other Layer. Light white grey, sandy silt. Located in the NE end of the trench.	Flint	
13904	Cut		1.1	0.64	Pit		
13905	Fill	13904	1.1	0.28	Primary Fill. Dark yellowish grey. Sandy silt.	Flint	
13906	Fill	13904	1.1	0.17	Secondary Fill. Light yellowish grey, sandy silt.	Flint	
13907	Cut		0.34	0.24	Ditch		
13908	Fill	13907	0.34	0.24	Secondary Fill. Light yellowish grey. Sandy silt.		
13909	Fill	13904	1.1	0.15	Other Fill. Colluvial fill. Mid red brown, silty sand with pebble inclusions.		

13910	Layer				Natural. Light blueish grey with orange mottling, silty clay, compact		
13911	Cut		0.76	0.54	Tree Throw. Irregular tree throw with two fills		
13912	Fill	13911	0.76	0.3	Primary Fill. Mid grey blue, clayey silt.	Flint	Mesolithic
13913	Fill	13911	0.76	0.26	Secondary Fill. Mid white yellow, clayey silt.	Flint	Mesolithic

#### Trench 140

General description					Orientation		N-S
Trench revealed one possible pond like feature, covered by colluvium layers. The lower section consists of redeposited fluvial sand and gravel. Thanet Sand recorded at the base.					Length (m)		30
					Width (m)		6
					Avg. depth (m)		2
Context No.	Type	Fill Of	Width (m)	Depth (m)	Description	Finds	Date
14000	Layer		6	0.35	Ploughsoil. Dark greyish brown clayey silt		
14001	Layer		6	0.2	Colluvial Layer. Pale grey clayey silt with pale yellowish mottling. Firm.		
14002	Layer		6	0.18	Colluvial Layer. Mid yellowish brown sandy silt. Very rare pebbles and chalk. Firm.		
14003	Cut		2.75	1	Pond. Pond at N end of trench		
14004	Fill	14003	2.75	1	Other Fill. Soft dark to light bluish grey clayey sandy silt, same as 14010	Flint, A. Bone	
14005	Layer		2	0.15	Alluvial Layer. Soft to firm light grey clayey silt with frequent light brownish red oxidized lenses	Flint	
14006	Layer		6	0.4	Alluvial Layer. Soft mixed lights in grey and white sandy silt with very frequent light brownish red oxidized lenses		
14007	Layer		6	0.1	Other Layer. Dark grey clayey silt. Homogeneous and stoneless. Firm.		
14008	Layer		6	0.38	Other Layer. Mid reddish brown mid to coarse sand with rounded gravel. Loose.		
14009	Layer				Natural. Olive fine sand. Loose.		
14010	Layer			0.32	Other Layer. Dark grey clayey silt. Soft. Same		



					as the possible fill of pond 14004		
14011	Layer			0.21	Other Layer. Yellowish grey mid to coarse sand with gravel. Loose.		
14012	Layer			0.25	Colluvial Layer. Strong brown clayey silt. Homogeneous and firm. Stoneless.		

### Trench 141

General description					Orientation		NW-SE
Trench revealed single pit and a natural water channel covered by a colluvium layer. Consists of ploughsoil and subsoil overlying natural geology of colluvium.					Length (m)		30
					Width (m)		2
					Avg. depth (m)		0.6
Context No.	Type	Fill Of	Width (m)	Depth (m)	Description	Finds	Date
14100	Layer			0.35	Ploughsoil. Mid greyish-brown silty sand	Flint	
14101	Layer			0.15	Subsoil. Soft to friable light greyish brown clayey sandy silt. Same as 14103	Flint	
14102	Layer				Natural. Light yellowish red sandy clay		
14103	Layer			0.15	Subsoil. Soft to friable light greyish brown clayey sandy silt. Same as 14101		
14104	Layer			0.2	Buried soil. Brittle/friable light brownish grey silty sand with frequent manganese concentrations.	Flint, Pot	MBA-MIA
14105	Layer			0.1	Other Layer. Mixed light brownish grey and light brownish red medium sandy gravel. Late Pleistocene to early Holocene slope deposit		
14106	Layer			0.05	Other Layer. Friable light grey medium sand		
14107	Cut		0.44	0.12	Pit		
14108	Fill	14107	0.44	0.12	Primary Fill. Compact, medium blackish grey, clay silt, occasional pot and worked flint	Flint, Pot	LNeo/EBAE. Neo or MBA-MIA
14109	Cut		1.2	0.4	Natural Feature		
14110	Fill	14109	1.2	0.4	Primary Fill. Light yellowish grey silty clay	Flint, Pot	Mesolithic E. Roman

### Trench 142

General description					Orientation		E-W
Trench devoid of archaeology. Consisted of ploughsoil and subsoil					Length (m)		30
					Width (m)		2.1

						Avg. depth (m)	0.65
Context No.	Type	Fill Of	Width (m)	Depth (m)	Description	Finds	Date
14200	Layer			0.32	Ploughsoil. Dark greyish brown silt few flint pebbles		
14201	Layer			0.22	Subsoil. Brown slightly clayey silt stone free		
14202	Layer				Natural. Mid brown orange clayey sand with gravel inclusions		
<b>Trench 143</b>							
General description					Orientation		E-W
Trench devoid of Archaeology. Ploughsoil overlaying a layer of subsoil, covering natural					Length (m)		30
					Width (m)		2
					Avg. depth (m)		0.5
Context No.	Type	Fill Of	Width (m)	Depth (m)	Description	Finds	Date
14300	Layer			0.25	Ploughsoil. Mid greyish-brown silty sand		
14301	Layer			0.2	Subsoil. Mid reddish-brown silty sand	Flint	
14302	Layer				Natural. Light yellowish red silty sand		
<b>Trench 144</b>							
General description					Orientation		N-S
Trench devoid of Archaeology. Ploughsoil overlaying a layer of subsoil, covering natural					Length (m)		30
					Width (m)		2
					Avg. depth (m)		0.5
Context No.	Type	Fill Of	Width (m)	Depth (m)	Description	Finds	Date
14400	Layer			0.3	Ploughsoil. Mid greyish-brown silty sand		
14401	Layer			0.2	Subsoil. Mid reddish-brown silty sand		
14402	Layer				Natural. Light yellowish grey sand		
<b>Trench 145</b>							
General description					Orientation		NW-SE
Trench devoid of Archaeology. Topsoil overlaying two colluvial contexts, on top of reworked Thanet sand					Length (m)		30
					Width (m)		2
					Avg. depth (m)		0.6
Context No.	Type	Fill Of	Width (m)	Depth (m)	Description	Finds	Date
14500	Layer			0.25	Ploughsoil. Dark greyish brown slightly clayey silt		
14501	Layer			0.23	Colluvial Layer. Pale reddish brown, slightly clayey silt		

14502	Layer			0.2	Colluvial Layer. Mid yellowish brown slightly clayey silty sand		
14503	Layer			0.3	Other Layer. Dark yellowish brown with light yellowish mottling. Silty sand. Possible reworked Thanet sand?		
<b>Trench 146</b>							
General description					Orientation		N-S
Trench devoid of Archaeology and consisted of ploughsoil, Holocene colluvium and Pleistocene Head deposit covering weathered Thanet Sand.					Length (m)		30
					Width (m)		6
					Avg. depth (m)		0.45
Context No.	Type	Fill Of	Width (m)	Depth (m)	Description	Finds	Date
14600	Layer			0.35	Ploughsoil. Mid greyish-brown silty sand	Flint	
14601	Layer			0.1	Colluvial Layer. Mid reddish brown sandy silt. Firm.		
14602	Layer				Other Layer. Reddish brown clayey sand with abundant rounded pebbles. Compact.		
14603	Layer			1	Natural. Light olive fine to mid sand with yellow red mottling and iron pans. Loose.		
<b>Trench 147</b>							
General description					Orientation		N-S
Trench devoid of Archaeology and consisted of ploughsoil covering a gravelly Head deposit. Thanet Sand recorded on at the base.					Length (m)		30
					Width (m)		6
					Avg. depth (m)		0.45
Context No.	Type	Fill Of	Width (m)	Depth (m)	Description	Finds	Date
14700	Layer			0.24	Ploughsoil. Mid greyish brown silt. Common inclusions of stones 1-5cm rounded and angular. Bou dark clear.		
14701	Layer		6	0.6	Subsoil. Light brown w/reddish yellow hue, silt with trace clay. Loose. Rare inclusions rounded and angular stones 1-4cm. Boundary clear.		
14702	Layer		6	1.25	Natural. Light bluish greenish grey fine sand with very frequent light yellowish red oxidised lenses. Thanet Sands?		

14703	Layer		6	0.3	Colluvial Layer. 0.32-0.62m. Light brown w/reddish yellow hue. Sandy silt. Mottled in parts w/reddish brown. Gravel terrace. Boundary diffuse.		
14704	Layer		6	0.16	Colluvial Layer. 0.62-0.78m. Light yellowish brown mottled w/reddish brown. Silty sand. Gravel terrace/deposit. Very firm. Boundary clear.		
14705	Layer			0.36	Colluvial Layer. 0.84-1.2m. Reddish yellow sand w/heavy gravel deposits/ gravel terrace. Very firm. Boundary diffuse.		
14706	Layer			0.22	Colluvial Layer. Mid-dark red sand mottled with yellowish red. Gravel deposit/terrace. Firm. Boundary clear.		

#### Trench 148

General description					Orientation	N-S	
Trench devoid of Archaeology and Trench devoid of Archaeology and consisted of ploughsoil covering a gravelly Head deposit. Thanet Sand recorded on at the base.					Length (m)	30	
					Width (m)	6	
					Avg. depth (m)	0.5	
Context No.	Type	Fill Of	Width (m)	Depth (m)	Description	Finds	Date
14800	Layer			0.3	Ploughsoil. Firm mid greyish brown clayey silt		
14801	Layer			0.15	Colluvial Layer. Soft light greenish grey sandy silt.		
14802	Layer			0.45	Natural. Soft light greyish green silty sand. Thanet Sands.		
14803	Layer			0.15	Colluvial Layer. Soft mid greyish brown sandy silt		
14804	Layer			0.3	Other Layer. Compact light brownish grey medium sandy gravel.		
14805	Layer				Natural. Soft light pinkish grey fine silty sand. Thanet Sands		

#### Trench 149

General description					Orientation	NE-SW
Trench revealed one linear running ENE-WSW. Consists of ploughsoil and subsoil overlying a shallow colluvium and the natural geology.					Length (m)	30
					Width (m)	2
					Avg. depth (m)	0.56

Context No.	Type	Fill Of	Width (m)	Depth (m)	Description	Finds	Date
14900	Layer			0.25	Ploughsoil. Dark greyish-brown silty sand		
14901	Layer			0.2	Subsoil. Light greyish-brown silty sand	Flint	
14902	Layer			0.18	Colluvial Layer. Light reddish-grey silty sand		
14903	Void						
14904	Layer				Other Layer. Pale grey yellow silty sand with gravel pockets. Same as 14906	Flint, Pot	LBA-EIA
14905	Cut		0.27	0.15	Ditch		
14906	Layer				Natural. Light yellowish grey Sandy silt with inclusions of manganese and iron fragments. Same as 14904		
14907	Fill	14905	0.5	0.21	Primary Fill. Primary fill consisting of gravel and P. Grit	Pot	Roman
14908	Fill	14908	0.27	0.15	Tertiary Fill. Light yellowish grey Sandy silt		

<b>Trench 150</b>							
General description					Orientation		E-W
Trench revealed 2 linears running SSE-NNW and SSW-NNE. Consists of ploughsoil and subsoil overlying natural geology					Length (m)		30
					Width (m)		2.1
					Avg. depth (m)		0.45
Context No.	Type	Fill Of	Width (m)	Depth (m)	Description	Finds	Date
15000	Layer		2.1	0.25	Ploughsoil. Mid brown grey Sandy silt	Flint	
15001	Layer		2.1	0.15	Subsoil. Mid orange brown silty sand		
15002	Layer		2.1	0.05	Natural. Mixed gravel patches with mid yellow orange silty sand		
15003	Cut		0.85	0.23	Ditch.		
15004	Fill	15003	0.85	0.23	Secondary Fill.	Flint	
15005	Cut		0.73	0.13	Ditch		
15006	Fill	15005	0.73	0.13	Secondary Fill. Mid-pale yellowy brown sandy silt	Flint	
15007	Cut		1.05	0.14	Natural Feature. Mid greyish brown clayey sand, loose friable compaction.		
<b>Trench 151</b>							
General description					Orientation		N-S

Trench revealed 4 ditches, 2 natural gullies and pit. Consists of ploughsoil overlying sandy clay head deposit.						Length (m)	30
						Width (m)	2
						Avg. depth (m)	0.3
Context No.	Type	Fill Of	Width (m)	Depth (m)	Description	Finds	Date
15100	Layer			0.3	Ploughsoil. Dark brownish grey clayey silt with occasional sub-angular flint fragments and rounded pebbles.		
15101	Layer				Natural. Head deposit. Mid yellowish and reddish brown sandy clay, compact with frequent patches of gravel.		
15102	Void						
15103	Void						
15104	Void						
15105	Void						
15106	Cut		2	0.2	Pit. Shallow pit. Heavy presence of charcoal along with some pieces of pottery. Few inclusions in the form of rounded pebbles		
15107	Fill	15106	2	0.2	Secondary Fill. Dark brownish grey sandy clay, heavy presence of charcoal	FC, Flint, Pot	MIA?
15108	Cut		2.42	0.67	Ditch. NW-SE		
15109	Fill	15108	0.39	0.09	Primary Fill. Dark brownish grey silty sand		
15110	Fill	15108	0.62	0.14	Primary Fill. Compact mid greyish brown gravelly sand		
15111	Fill	15108	1.89	0.2	Secondary Fill. Compact light brownish grey sandy silt	Flint, Pot, A. Bone	MIA
15112	Fill	15108	2.16	0.47	Secondary Fill. Soft dark greyish brown sandy silt	FC, Flint, Pot	MIA
15113	Cut		0.58	0.21	Ditch. NW-SE		
15114	Fill	15113	0.58	0.21	Secondary Fill. Soft dark reddish brown sandy silt		
15115	Cut		1	0.22	Ditch. Linear running E-W. Moderately sloped concave sides, somewhat clear break of slope at base.		
15116	Fill	15115	1	0.22	Secondary Fill. Friable mid brown orange sandy clay. <5% small gravel inclusions. Pot and CBM finds.	FC, Flint, Pot	E.Roman
15117	Cut		0.14	0.06	Natural Feature. Small gully running E-W.		

					Shallow, concave base with moderately sloped sides.		
15118	Fill	15117	0.14	0.06	Other Fill. Friable mid grey orange sandy clay. No inclusions or finds.		
15119	Cut		0.98	0.11	Ditch. Terminus of linear running E-W. Moderately sloped concave sides with slight break of slope at base. Base somewhat irregular.		
15120	Fill	15119	0.98	0.11	Secondary Fill. Friable mid grey brown sandy clay. <5% small gravel inclusions. Pot and CBM finds.	FC, Flint, Pot	LIA-ER
15121	Cut		0.2	0.08	Natural Feature. Natural gully, Light yellowish brown sandy silt.		

### Trench 152

General description					Orientation	E-W	
Trench revealed 3 linears and 2 pits Consists of ploughsoil and subsoil over two colluvial layers					Length (m)	30	
					Width (m)	2	
					Avg. depth (m)	0.45	
Context No.	Type	Fill Of	Width (m)	Depth (m)	Description	Finds	Date
15200	Layer			0.32	Ploughsoil. Mid greyish brown clayey sandy silt	Flint	
15201	Layer			0.13	Colluvial Layer. Friable very light reddish brown sandy silt		
15202	Layer				Other Layer. Mid brownish red sandy clay. Head deposit		
15203	Layer			0.27	Other Layer. Friable light yellowish brown slightly sandy silt. Possible colluvium/slopewash.		
15204	Cut		1.33	0.35	Ditch		
15205	Fill	15204	1.33	0.14	Tertiary Fill. Light yellow-white sandy clay, hardened	Flint	
15206	Cut		1.24	0.38	Ditch		
15207	Fill	15206	1.24	0.12	Secondary Fill. Mid yellow brown with Common rounded gravel and occasional sub rounded pebbles.		
15208	Fill	15206	1.17	0.26	Secondary Fill. Firm Sandy silt Light yellow brown.		
15209	Cut		1.2	0.43	Pit		

15210	Fill	15209	1.2	0.43	Deliberate Backfill. Dark brown-orange sandy clay, compact		
15211	Cut		0.7	0.26	Ditch		
15212	Fill	15211	0.7	0.26	Secondary Fill. Mid greyish brown Sandy clay, firm		
15213	Cut		1.06	0.28	Pit		
15214	Fill	15213	1.06	0.28	Tertiary Fill. Mid orange-brown sandy clay, compact		
15215	Fill	15204	0.76	0.1	Tertiary Fill. Mid orange-brown silty clay, compact		

### Trench 153

General description						Orientation	N-S
Trench consists of ploughsoil and colluvium overlying sandy clay head deposit. Trench revealed two natural features one of which was excavated.						Length (m)	30
						Width (m)	2
						Avg. depth (m)	0.36
Context No.	Type	Fill Of	Width (m)	Depth (m)	Description	Finds	Date
15300	Layer			0.36	Ploughsoil. Dark grey clayey silt		
15301	Layer			0.18	Colluvial Layer. Dark reddish brown clayey silt		
15302	Layer				Natural. Head deposit. Mid reddish brown sandy clay.		
15303	Cut	15303	2.26	0.14	Natural Feature. Soft light brownish grey sandy silt.		
15304	Unexc feature		1.87		Natural Feature. Rooting. Dark greyish brown clayey silt mixed with light blueish grey clayey silt		

### Trench 154

General description						Orientation	NW-SE
Trench consists of ploughsoil and colluvium overlying sandy clay head deposit. Trench devoid of archaeology.						Length (m)	30
						Width (m)	2
						Avg. depth (m)	0.37
Context No.	Type	Fill Of	Width (m)	Depth (m)	Description	Finds	Date
15400	Layer			0.34	Ploughsoil. Dark grey clayey silt		
15401	Layer			0.21	Colluvial Layer. Dark reddish brown clayey silt		
15402	Layer				Natural. Mid reddish brown sandy clay		
15403	Cut		1.02	0.13	Natural Feature. Soft light brownish grey sandy silt		



<b>Trench 155</b>							
General description					Orientation		E-W
Trench devoid of archaeology. Consists of ploughsoil and colluvium overlying natural geology of sandy clay.					Length (m)		30
					Width (m)		2
					Avg. depth (m)		0.34
Context No.	Type	Fill Of	Width (m)	Depth (m)	Description	Finds	Date
15500	Layer			0.34	Ploughsoil. Dark grey clayey silt		
15501	Layer			0.15	Colluvial Layer. Light greyish brown clayey silt		
15502	Layer				Natural. Mid reddish brown sandy clay		
<b>Trench 156</b>							
General description					Orientation		N-S
Trench devoid of archaeology. Consists of ploughsoil and colluvium overlying sandy clay head deposit. Natural features recorded in trench.					Length (m)		30
					Width (m)		2
					Avg. depth (m)		0.23
Context No.	Type	Fill Of	Width (m)	Depth (m)	Description	Finds	Date
15600	Layer			0.36	Ploughsoil. Dark grey clayey silt		
15601	Layer			0.24	Colluvial Layer. Light greyish brown clayey silt		
15602	Layer				Natural. Mid reddish brown sandy clay		
15603	Cut		0.79	0.11	Natural Feature. Soft dark greyish brown sandy silt		
15604	Cut		0.31	0.19	Natural Feature. Natural gully		
15605	Fill	15604	0.31	0.19	Other Fill. Mid reddish brown sandy clay, moderately compact with rare rounded pebbles.		
15606	Cut		0.32	0.16	Other Cut. Natural gully		
15607	Fill	15606	0.32	0.16	Other Fill. Mid reddish brown sandy clay with rare rounded pebbles.		
<b>Trench 157</b>							
General description					Orientation		NE-SW
Trench devoid of archaeology. Consists of ploughsoil and colluvium overlying natural geology of sandy clay.					Length (m)		30
					Width (m)		2
					Avg. depth (m)		0.36
Context No.	Type	Fill Of	Width (m)	Depth (m)	Description	Finds	Date
15700	Layer			0.36	Ploughsoil. Dark grey clayey silt	Flint	

15701	Layer			0.18	Colluvial Layer. Mid greyish brown clayey silt		
15702	Layer				Natural. Mid reddish brown sandy clay		
<b>Trench 158</b>							
General description					Orientation		E-W
Trench devoid of archaeology. Consists of ploughsoil and colluvium overlying natural geology of sandy clay. Natural feature recorded.					Length (m)		30
					Width (m)		2
					Avg. depth (m)		0.34
Context No.	Type	Fill Of	Width (m)	Depth (m)	Description	Finds	Date
15800	Layer			0.34	Ploughsoil. Dark grey clayey silt		
15801	Layer			0.24	Colluvial Layer. Light greyish brown clayey silt		
15802	Layer				Natural. Mid reddish brown sandy clay		
15803	Cut		0.83	0.17	Natural Feature. Soft light greyish brown clayey silt		
<b>Trench 159</b>							
General description					Orientation		NW-SE
Trench revealed single pit. Consists of ploughsoil and colluvium overlying sandy clay head deposit.					Length (m)		30
					Width (m)		2
					Avg. depth (m)		0.37
Context No.	Type	Fill Of	Width (m)	Depth (m)	Description	Finds	Date
15900	Layer			0.37	Ploughsoil. Dark grey clayey silt		
15901	Layer			0.18	Colluvial Layer. Light greyish brown clayey silt		
15902	Layer				Natural. Mid reddish brown sandy clay		
15903	Cut		1.47	0.46	Pit		
15904	Fill	15903	1.47	0.45	Secondary Fill. Dark brownish grey sandy silt, moderately compact with occasional sub-rounded stones.	Flint	
<b>Trench 160</b>							
General description					Orientation		NW-SE
Trench devoid of archaeology. Consists of ploughsoil and colluvium overlying natural geology of sandy clay. Natural feature recorded.					Length (m)		30
					Width (m)		2
					Avg. depth (m)		0.32
Context No.	Type	Fill Of	Width (m)	Depth (m)	Description	Finds	Date
16000	Layer			0.32	Ploughsoil. Dark grey clayey silt		
16001	Layer			0.18	Colluvial Layer. Mid greyish brown clayey silt		

16002	Layer				Natural. Mid reddish brown sandy clay		
16003	Cut		1.12	0.12	Natural Feature. Likely tree bowl. Soft mid greyish brown sandy silt.		
<b>Trench 161</b>							
General description					Orientation	NW-SE	
Trench revealed two pits. Consists of ploughsoil and colluvium overlying natural geology of sandy clay.					Length (m)	30	
					Width (m)	2	
					Avg. depth (m)	0.29	
Context No.	Type	Fill Of	Width (m)	Depth (m)	Description	Finds	Date
16100	Layer			0.29	Ploughsoil. Dark grey clayey silt		
16101	Layer			0.21	Colluvial Layer. Light yellowish brown clayey silt		
16102	Layer				Natural. Head deposit. Mid reddish brown sandy clay		
16103	Cut		1.26	0.28	Pit		
16104	Fill	16103	1.26	0.28	Secondary Fill. Soft light brownish grey sandy silt	Flint, Pot	MBA-MIA
16105	Cut		0.21	0.06	Pit		
16106	Fill	16105	0.21	0.06	Secondary Fill. Compact dark greyish brown sandy silt		
<b>Trench 162</b>							
General description					Orientation	NW-SE	
Trench revealed one ditch running NNE-SSE. Consists of topsoil overlying a thin organic subsoil. Underlying this two slopewash layers and several Pleistocene deposits. At the base of section a possible redeposited fluvial sand deposit.					Length (m)	30	
					Width (m)	6	
					Avg. depth (m)	2	
Context No.	Type	Fill Of	Width (m)	Depth (m)	Description	Finds	Date
16200	Layer		6	0.25	Ploughsoil. Firm mid greyish brown sandy silty clay	Flint	
16201	Layer		6	0.05	Subsoil. Firm mid reddish brown clayey silt		
16202	Layer		6	0.3	Alluvial Layer. Soft light bluish grey clayey sandy silt		
16203	Layer		6	0.1	Alluvial Layer. Soft light greyish brown and light reddish brown silt	Flint	
16204	Layer		6		Alluvial Layer. Soft light brownish grey medium sand		
16205	Cut		1.5		Ditch. Linear running NE-SW. Only recorded in plan		
16206	Fill	16205	1.5		Primary Fill. Dark yellowish brown, sandy		

					silt, friable. Inclusions of iron staining and modern organics		
16207	Layer			0.08	Other Layer. Soft light yellowish red sandy silt		
16208	Layer			0.4	Other Layer. Soft light pinkish grey and mid yellowish red silty sand		
16209	Layer			0.28	Other Layer. Soft light brownish grey silty sand		
16210	Layer			0.15	Other Layer. Soft light greyish brown silty sand. Slope deposit.		
<b>Trench 163</b>							
General description						Orientation	NS
Trench revealed 3 linears and a tree throw. Trench located on the north facing slope. Contains Holocene colluvium cut by 3 ditches and a tree throw. The lower sequence consists of a Pleistocene slopewash/fluvial deposits. Thanet Sand recorded at the base.						Length (m)	30
						Width (m)	6
						Avg. depth (m)	1.8
Context No.	Type	Fill Of	Width (m)	Depth (m)	Description	Finds	Date
16300	Layer			0.35	Ploughsoil. Brownish grey sandy silt. Firm.		
16301	Layer			0.1	Colluvial Layer. Mid yellowish brown sandy silt. Firm and stoneless. Manganese staining recorded.		
16302	Layer			0.29	Colluvial Layer. Strong brown clay silt. Manganese staining common. Firm and stoneless.		
16303	Layer			0.35	Other Layer. Yellowish brown sandy silt with calcite inclusions. Soft.		
16304	Layer			0.3	Other Layer. Dark yellowish brown clayey/silty sand with calcite inclusions. Soft.		
16305	Layer			0.22	Other Layer. Greyish brown coarse sand with abundant rounded pebbles. Loose.		
16306	Layer			0.08	Other Layer. Red coarse sand. Loose.		
16307	Layer				Natural. Olive fine sand. Loose.		
16308	Layer			0.17	Colluvial Layer. Strong brown clayey silt. Firm and stoneless.	Flint	
16309	Cut		0.67	0.24	Ditch		
16310	Fill	16309	0.67	0.24	Secondary Fill. Friable, medium whitish grey, clay silt, occasional pot and worked flint,	Flint, Pot	E. Neo or MBA-MIA

					moderate charcoal flecks		
16311	Cut		0.4	0.24	Ditch		
16312	Fill	16311	0.4	0.24	Primary Fill. Soft, mid greyish brown, sandy clay	Flint	
16313	Cut		0.58	0.1	Ditch		
16314	Fill	16313	0.58	0.1	Primary Fill. Soft, medium brownish grey, clay silt, occasional rounded stones		
16315	Cut		0.6	0.19	Tree Throw		
16316	Fill	16315	0.6	0.19	Primary Fill. Soft light greyish brown sandy clay	Flint, Pot	E. Neo or MBA-MIA

### Trench 164

General description					Orientation	E-W
Trench revealed A ditch and pit recorded in the western part of the trench. A large tree throw recorded in the middle of the trench. Consists of ploughsoil covering brick earth type deposits and slopewash deposits, a possible fluvial and possible reworked Thanet Sand.					Length (m)	30
					Width (m)	6
					Avg. depth (m)	0.62

Context No.	Type	Fill Of	Width (m)	Depth (m)	Description	Finds	Date
16400	Layer			0.28	Ploughsoil. Dark greyish brown, moderate clayey silt		
16401	Layer			0.16	Subsoil. Light yellowish brown mottled with mid reddish brown oxidised sediment. Slightly clayey silt.		
16402	Layer			0.18	Other Layer. Mid reddish brown mottled with mid grey. Silty clay		
16403	Layer			0.2	Other Layer. Light whiteish sediment mottled with a mid-reddish brown. Highly calciferous sediment.		
16404	Layer			0.24	Other Layer. Light yellowish brown mottled by mid reddish brown clayey silt		
16405	Layer			0.1	Other Layer. Mid greyish brown, clayey silt. 5% reddish brown mottling		
16406	Layer			0.14	Other Layer. Mid yellowish brown mottled with mid reddish brown, clayey sand.		
16407	Layer			0.06	Other Layer. Light olive sandy silt. Mid reddish-brown infill of worming voids.		
16408	Cut		4	0.24	Tree Throw		

16409	Fill	16408	4	0.1	Primary Fill. Compact, mixed medium greyish blue, silty clay, occasional small sub-angled stones		
16410	Cut		0.82	0.19	Pit		
16411	Fill	16410	0.82	0.11	Primary Fill. Soft, medium greyish brown, silty clay, occasional charcoal flecks		
16412	Fill	16410	0.75	0.08	Secondary Fill. Soft, medium greyish brown, silty clay, frequent charcoal flecks and baked clay pieces		
16413	Cut		0.57	0.17	Ditch		
16414	Fill	16413	0.57	0.17	Primary Fill. Soft, medium whitish grey, silty clay, occasional charcoal flecks		
16415	Fill	16408	0.43	0.13	Secondary Fill. Base not fully excavated		
16416	Fill	16408	1.35	0.25	Tertiary Fill. Base not fully excavated		

### Trench 165

General description					Orientation	NW-SE	
Trench revealed one linear at NW end of trench. Consisted of topsoil overlying peaty buried soil, similar to peaty deposit in 7a area. Later of fine alluvium and gravel recorded at the base.					Length (m)	0.3	
					Width (m)	6	
					Avg. depth (m)	0.6	
Context No.	Type	Fill Of	Width (m)	Depth (m)	Description	Finds	Date
16500	Layer			0.26	Ploughsoil. Soft to slightly firm mid greyish brown clayey sandy silt	Flint	
16501	Layer			0.23	Buried soil. Soft to slightly firm dark bluish grey and dark reddish brown clayey silt. Probably alluvial in origin.	Flint	
16502	Layer			0.25	Alluvial Layer. Soft light greyish green clayey silty sand with frequent light yellowish red and light brownish red lenses. Redeposited brickearth or possibly Thanet Sands?	Flint	
16503	Layer			0.17	Alluvial Layer. Weakly cemented dark yellowish red and light greenish grey silty sandy gravel		
16504	Layer				Alluvial Layer. Friable light greenish grey and mid greyish brown		

					medium sand. Top of Thanet Sands?		
16505	Cut		4.4	0.65	Ditch. Unexcavated modern N-S boundary ditch. Section only recorded as sketch/photo		
16506	Fill	16505	4.4	0.65	Primary Fill. Fill of modern boundary ditch. Section only recorded as sketch/photo		
<b>Trench 166</b>							
General description						Orientation	NS
Trench revealed a pond with a modern ditch running into it. Trench located within a shallow valley. Consists of ploughsoil covering Holocene colluvium and a possible redeposited fluvial sand and gravel. Thanet Sand recorded at the base.						Length (m)	30
						Width (m)	6
						Avg. depth (m)	0.34
Context No.	Type	Fill Of	Width (m)	Depth (m)	Description	Finds	Date
16600	Layer			0.34	Ploughsoil. Mid brownish grey. Sandy silt. Firm. Rooting.		
16601	Layer			0.12	Colluvial Layer. Mid yellowish brown sandy silt. Firm. Very rare pebbles and manganese staining.		
16602	Layer			0.17	Colluvial Layer. Strong brown clayey silt. Firm. Occasional manganese staining.		
16603	Layer			0.13	Colluvial Layer. Strong brown clayey silt. Firm and stoneless.		
16604	Layer			0.24	Other Layer. Grey to red sand with abundant gravel. Loose.		
16605	Layer			0.12	Other Layer. White chalky silt. Post-depositional accumulation of calcite.		
16606	Layer				Natural. Dark olive grey fine sand. Soft.		
16607	Cut			0.6	Pond. Modern. High water table/ground water. Machine dug. Sketch sec. Sub oval, mod concave sides, flat base. Width unknown as not allowed in trench due to water. Length 12m		
16608	Fill	16607		0.6	Secondary Fill. Machine excavated. Due to high water table section was sketched. Friable mid brownish green. Sandy clay with rare pebbles.		

16609	Cut		0.72	0.22	Ditch		
16610	Fill	16609	0.72	0.22	Primary Fill. Dark grey brown clayey silt, loose with occasional small stones.	Pipe	c 1780-1830
<b>Trench 167</b>							
General description						Orientation	N-S
Trench revealed two tree throws and 1 modern ditch. Trench located on the north facing slope. Consists of ploughsoil covering colluvial layers and a possible head deposit. Ditch cutting the colluvial layers recorded.						Length (m)	30
						Width (m)	2
						Avg. depth (m)	0.62
Context No.	Type	Fill Of	Width (m)	Depth (m)	Description	Finds	Date
16700	Layer			0.32	Ploughsoil. Dark grey brown, firm silty clay		
16701	Layer			0.16	Subsoil. Mid yellowish brown, friable sandy silt.		
16702	Layer			0.14	Colluvial Layer. Strong brown clayey silt. Stoneless and firm.		
16703	Layer			0.18	Colluvial Layer. Strong brown clayey silt with manganese staining. Firm.		
16704	Layer			0.13	Colluvial Layer. Strong brown clayey silt. Firm and stoneless.		
16705	Layer				Other Layer. Yellowish red sand with rounded pebbles and cobbles.		
16706	Layer			0.3	Other Layer. Pale grey clayey silt with pale yellowish mottling. Firm.		
16707	Cut		3	0.46	Ditch. Vertical sides. Cuts colluvial layers.		
16708	Layer			0.33	Other Layer. Pale grey clayey silt. Firm Very rare pebbles.		
16709	Layer			0.3	Other Layer. Pale grey clayey silt with pale yellowish mottling. Firm.		
16710	Cut		1.36	0.4	Tree-throw hole. Sub semi-circular. Irregular base with stepped, gently sloping sides. Quarter section against bulk.		
16711	Fill	16710	0.86	0.3	Other Fill. Friable mid grey brown silty clay. <5% small gravel inclusions. One flint flake recovered.	Flint	
16712	Fill	16710	1.12	0.26	Other Fill. Friable mottled light yellow brown and light grey brown silty clay. <5% small gravel inclusions.	Flint	



					One flint flake recovered from surface.		
16713	Cut		1.61	0.15	Tree-throw hole.		
16714	Fill	16713	1.61	0.15	Other Fill. Light brownish grey with yellow mottling, silty clay, firm	FC, Flint, A. Bone	C15th-C17th
16715	Fill	16707	3	0.46	Secondary Fill. Light brownish grey, clayey silt, firm		

### Trench 168

#### General description

Trench revealed one linear at west end. Consists of ploughsoil, thin layer of leached which increases in depth from east to west, and 3 layers of slopewash, overlying gravelly head deposits. Very water logged

#### Orientation

E-W

#### Length (m)

30

#### Width (m)

6

#### Avg. depth (m)

0.3

Context No.	Type	Fill Of	Width (m)	Depth (m)	Description	Finds	Date
16800	Layer		6	0.3	Ploughsoil. Dark greyish brown sandy clayey silt		
16801	Layer		6	0.11	Other Layer. Pale grey silt with pale yellowish mottling. Leached slopewash		
16802	Layer		6	0.22	Other Layer. Soft light reddish brownish grey clayey silt. Slopewash.		
16803	Layer		6	0.26	Other Layer. Soft light brownish grey with whitish calcified lenses and frequent mid greenish yellowish red mottling. Decalcified slopewash.		
16804	Layer		6	0.25	Other Layer. Soft light brownish grey sandy silt. Slopewash.		
16805	Layer				Natural. Mid orangish brown, gravelly sand. Same as 16808		
16806	Cut		2.2	0.6	Ditch. NE-SW oriented modern ditch		
16807	Fill	16806	2.2	0.6	Primary Fill. Dark greyish brown sandy silt friable modern fill		
16808	Layer				Other Layer. Gravel head deposit. Same as 16805		

### Trench 169

#### General description

Trench devoid of archaeology. Consists of ploughsoil and subsoil above alluvial deposits, on top of Thanet sand and banded sands and gravels.

#### Orientation

N-S

#### Length (m)

30

#### Width (m)

6

#### Avg. depth (m)

1

Context No.	Type	Fill Of	Width (m)	Depth (m)	Description	Finds	Date
16900	Layer		6	0.3	Ploughsoil. Dark greyish brown clayey silt		
16901	Layer		3	0.2	Subsoil. Mid brownish grey clayey silt with moderate mid brownish red oxidized patches.		
16902	Layer		3	0.15	Alluvial Layer. Mid brownish red clayey silt with moderate dark greyish blue, light brownish grey lenses.		
16903	Layer		3	0.35	Alluvial Layer. Light yellowish grey clayey silt, with frequent calcareous lenses.		
16904	Layer				Other Layer. Light greyish brown and light reddish orange sand lenses.		
16905	Layer				Other Layer. Waterlogged banded sands and gravels. Channel fill. Unable to record in depth due to trench edge collapse.		

#### Trench 170

##### General description

Trench revealed a single linear in the middle of the trench. Trench comprises two linear features and one possible natural feature cut into alluvium. a possible Pleistocene siltwash and gravelly Head deposit recorded in the auger. Archaeology is sealed by ploughsoil

##### Orientation

E-W

Length (m)

30

Width (m)

2

Avg. depth (m)

0.49

Context No.	Type	Fill Of	Width (m)	Depth (m)	Description	Finds	Date
17000	Layer		2	0.3	Ploughsoil. Mid greyish brown clayey silt	Flint	
17001	Layer		2	0.19	Subsoil. Reddish brown silty clay. Firm.		
17002	Layer		2	0.26	Alluvial Layer. Pale grey silty clay with pale yellowish mottling. Soft.	Flint	
17003	Layer			0.26	Other Layer. Pale yellowish grey silty clay. Soft.		
17004	Layer			0.25	Other Layer. Mid grey sandy clayey silt. Soft. Slightly mottled.		
17005	Layer				Other Layer. Mid yellowish grey coarse sand with gravel. Loose.		
17006	Cut		1.41	0.3	Ditch		
17007	Fill	17006	1.41	0.3	Primary Fill. Firm, dark greyish brown, silty clay		

<b>Trench 171</b>							
General description					Orientation		N-S
Trench devoid of archaeology. Consists of ploughsoil overlying natural alluvial clay.					Length (m)		30
					Width (m)		2
					Avg. depth (m)		0.7
Context No.	Type	Fill Of	Width (m)	Depth (m)	Description	Finds	Date
17100	Layer		2	0.35	Ploughsoil. Dark greyish brown clayey silt		
17101	Layer		2	0.35	Buried soil. Very dark brown clayey silt with very rare rounded pebbles. Firm Peaty soil		
17102	Layer			0.38	Alluvial Layer. Firm light brownish grey silty clay with frequent light yellowish red mottling		
17103	Layer			0.07	Other Layer. Mid grey clayey silt. Yellowish mottling and calcite inclusions recorded.		
<b>Trench 172</b>							
General description					Orientation		NS
Trench devoid of archaeology. Consists of ploughsoil and subsoil overlying natural of gravels and coarse sand					Length (m)		30
					Width (m)		2
					Avg. depth (m)		0.8
Context No.	Type	Fill Of	Width (m)	Depth (m)	Description	Finds	Date
17200	Layer			0.35	Ploughsoil. Soft to slightly firm mid brownish grey clayey sandy silt		
17201	Layer			0.2	Other Layer. Firm and compact light brownish red sandy clay. Pleistocene slope deposit.		
17202	Layer			0.25	Other Layer. Firm and compact mid brownish red sand clay with gravel. Pleistocene slope deposit.		
17203	Layer			0.2	Other Layer. Soft to friable light greyish green and light yellowish red clayey sand. Reworked Thanet Sands? Slope deposit?		
17204	Layer			0.2	Colluvial Layer. Soft to friable light greyish brown clayey sandy silt.		
17205	Layer				Other Layer. Compact to moderately cemented light greyish brown clayey sandy gravel.		

					Pleistocene slope deposit?		
<b>Trench 173</b>							
General description					Orientation		E-W
Trench devoid of archaeology. Consists of 2 colluvium layers present below ploughsoil and subsoil, present in the east and while one disappears in the middle of the trench. Natural ground pattern.					Length (m)		30
					Width (m)		6
					Avg. depth (m)		1.4
Context No.	Type	Fill Of	Width (m)	Depth (m)	Description	Finds	Date
17300	Layer		6	0.3	Ploughsoil. Dark greyish brown, sandy clayey silt with rounded pebbles. Friable.		
17301	Layer		6	0.17	Subsoil. Mid reddish brown, silty clay with very rare rounded pebbles. Firm	CBM, FC	C15th-C17th
17302	Layer		6	0.29	Colluvial Layer. Strong brown clayey silt. Firm and stoneless.		
17303	Layer		6	0.65	Colluvial Layer. Strong brown sandy clay/silt. Firm and stoneless.		
17304	Layer		2	0.05	Other Layer. Dark yellowish red coarse sand and clay with common pebbles and calcite inclusions. Compact.		
17305	Layer		6	0.05	Other Layer. Mid greyish brown, clayey sand with rounded pebbles. Firm		
17306	Cut				Natural Feature. Natural ground pattern; Mid brownish orange silty sand, loose, no inclusion visible		
17307	Layer				Other Layer. White grey chalky silt with fine sand and clay. Porous.		
<b>Trench 174</b>							
General description					Orientation		N-S
Trench revealed 1 pit recorded in geo section. Trench located at the north facing slope. Consists of ploughsoil covering series of Holocene colluvium and a possible old land surface. Pleistocene slopewash recorded in the lower section.					Length (m)		30
					Width (m)		6
					Avg. depth (m)		0.5
Context No.	Type	Fill Of	Width (m)	Depth (m)	Description	Finds	Date
17400	Layer			0.25	Ploughsoil. Dark grey brown clayey silt		
17401	Layer			0.2	Colluvial Layer. Mid yellowish brown clayey silt. Firm.		

17402	Layer			0.15	Colluvial Layer. Light yellow greyish clayey silt with charcoal flecks	Flint	
17403	Layer				Colluvial Layer. Strong brown clayey silt. homogeneous and firm. Stoneless.	Flint	
17404	Cut		0.4	0.3	Pit. A possible pit recorded in the geoarch section. Cuts a fine colluvium. V-shape.		
17405	Fill	17404	0.4	0.3	Deliberate Backfill. Mid yellowish brown silt mixed with charcoal. Firm.		
17406	Layer			0.21	Colluvial Layer. Light greyish yellow slightly sandy clayey silt. Manganese staining common. Firm.		
17407	Layer			0.15	Colluvial Layer. Mid yellowish brown clayey sandy silt. Firm and stoneless.		
17408	Layer			0.2	Other Layer. Mid brown silt with chalky lenses. Soft. Stoneless.		
17409	Layer			0.3	Other Layer. Mid yellowish brown silty sand with gravel. Soft.		
17410	Layer			0.24	Other Layer. Greyish red sand with common gravel. Loose.		
17411	Layer				Natural. Olive fine sand. Loose		

### Trench 175

General description					Orientation	E-W	
Trench revealed 2 linears and 4 possible pits at the east end, and complex archaeology at the west end including one large curvilinear ditch, possibly cut by 3 pits and 1 large feature of unknown formation and function. Consists of Ploughsoil and subsoil overlying colluvial layer which overlay natural geology.					Length (m)	30	
					Width (m)	2	
					Avg. depth (m)	0.67	
Context No.	Type	Fill Of	Width (m)	Depth (m)	Description	Finds	Date
17500	Layer		6	0.25	Ploughsoil. Mid grey brown slightly clayey silt		
17501	Layer		6	0.1	Subsoil. Mid yellowish brown slightly clayey silt with rare surrounded pebbles. Overlying colluvial deposit 17502		
17502	Layer		6	0.32	Colluvial Layer. Pale yellowish brown mottled occasionally with mid reddish brown specks (3%). Abundant manganese flecks	Flint	

17503	Cut		1.23	0.43	Ditch		
17504	Fill	17503		0.43	Primary Fill. Moderate mid brownish grey silty clay	Flint, Pot, A. Bone	MIA
17505	Layer			0.14	Colluvial Layer. Light grey mottled with a mid yellowish brown. Worming present with topsoil infill.		
17506	Layer			0.33	Colluvial Layer. Mid reddish brown clayey silt. Decalcified with decalcified bands towards base of context. Worming with topsoil infill and calcific sediment in vertical infill structure.	Flint	
17507	Layer			0.22	Other Layer. Head deposit. Mid yellowish brown mottled with light grey sediment. Clayey sand. Common sub angular pebbles held within matrix.		
17508	Layer			0.38	Natural. Pale olive green with a mid reddish brown (oxidised) upper boundary. Clayey sand. Calcific bands present from decalcification. Abundant sub angular pebbles and stones. Common large natural flints.		
17509	Cut		0.8	0.32	Ditch. Same as 17515		
17510	Fill	17509			Secondary Fill. Bluey - grey silty clay of moderate compaction	FC, Flint, Pot, A. Bone	PH
17511	Unexc feature		0.61		Pit. Mid grey, sandy silt.		
17512	Unexc feature		0.66		Pit. Mid grey, sandy silt.		
17513	Unexc feature		0.45		Pit. Mid grey, sandy silt.		
17514	Unexc feature		0.62		Pit. Mid grey, sandy silt.		
17515	Cut		0.8	0.32	Ditch. Same as 17509		
17516	Cut		1.18	0.85	Ditch. Possible ditch present pieces of worked flint and animal bone		
17517	Fill	17516	0.17	0.97	Tertiary Fill. Dark brown silty clay mottled with patches of reddish brown sandy silt		
17518	Fill	17516	1.18	0.45	Secondary Fill. Dark greyish blue silty clay		

17519	Fill	17516	1.1	0.39	Secondary Fill. Mid greyish blue silty clay	Flint, A. Bone	Early Neolithic
17520	Cut		1.92	0.32	Pit. Possible pit/ditch/ditch terminus		
17521	Cut		5.4	1.2	Pit		
17522	Fill	17521	5.4	0.6	Other Fill. Light orange brown with grey and white mottling, clayey silt, friable. Crushed CBM, charcoal and flint inclusions.		
17523	Fill	17520	1.92	0.32	Primary Fill		
17524	Cut		0.43	0.3	Pit. Possible pit circular in plan no inclusions no finds		
17525	Fill	17524	0.43	0.3	Primary Fill. Mid greyish blue sandy clay no inclusions no finds		
17526	Fill	17516	0.35	0.37	Secondary Fill. Light blueish grey silty clay mottled with orange mineral deposits		
17527	Cut		0.79	0.3	Pit. Possible pit sib-oval in plan. No inclusions no finds		
17528	Fill	17527	0.79	0.3	Primary Fill. Light blueish grey with orange mineral deposits no inclusions no finds		
17529	Layer		5.25	0.42	Other Layer. Silty clay light brownish grey presented no inclusions. Mottled with calcification deposits. Same as 17507.		
17530	Layer		1.18	0.05	Other Layer. Same as 17507.		
17531	Layer		2.43	0.28	Other Layer. Dark Orangey brown sandy clay. No inclusions present. Same as 17508.		

### Trench 176

General description					Orientation	E-W	
Trench revealed two small pits with burnt material at E end. In centre of trench there was a crouch burial. Also pale linear features at centre. Colluvium in base of trench contained flints. This was overlain by ploughsoil and subsoil.					Length (m)	30	
					Width (m)	2	
					Avg. depth (m)	0.6	
Context No.	Type	Fill Of	Width (m)	Depth (m)	Description	Finds	Date
17600	Layer		2	0.3	Ploughsoil. Mid greyish brown clayey silt	Flint	
17601	Layer		2	0.13	Subsoil. Mid yellowish brown sandy silt with dark greyish brown manganese patches		

17602	Layer		2	0.1	Colluvial Layer. Pale yellowish grey with mottling. Firm. Manganese staining common.		
17603	Layer		6	0.37	Colluvial Layer. Strong brown clayey silt. Firm and stoneless. Recorded in auger.		
17604	Cut		1	0.34	Pit		
17605	Fill	17604		0.08	Primary Fill. Orange brown clay sand		
17606	Fill	17604	0.92	0.56	Deliberate Backfill. Mid red, orange brown, clay sand. Burnt stone, and small flecks of charcoal	FC, Flint	
17607	Cut		0.5	0.2	Pit		
17608	Void						
17609	Fill	17607	0.5	0.15	Primary Fill. Charcoal rich deposit. Clay sand	FC	
17610	Fill	17607	0.48	0.05	Secondary Fill. Dark reddish brown clay sand with occ charcoal.		
17611	Cut		0.36	0.2	Ditch. Cut of narrow ditch running e-w		
17612	Fill	17611	0.36	0.2	Secondary Fill. Fill of ditch	Flint	
17613	Cut		0.32	0.19	Natural Feature. Possible ditch		
17614	Fill	17613	0.32	0.19	Secondary Fill. Light grey silt	Flint	
17615	Cut		0.82	0.13	Grave Cut. Crouched burial		
17616	Cut		0.43	0.12	Natural Feature. Possible ditch		
17617	Fill	17616	0.43	0.12	Secondary Fill. Light orangish white, sandy silt.	Flint	
17618	Layer			0.28	Other Layer. Pale brown sandy silt. Firm and stoneless.		
17619	Layer			0.18	Other Layer. Pale reddish brown clayey sand with rounded pebbles. Soft.		
17620	Layer				Natural. Olive sand. Loose with rounded pebbles. Recorded in the auger.	Flint	Mesolithic?
17621	Fill	17615	0.82	0.13	Grave Fill. Light Bluish grey silty sand. Firm	Flint, Pot	E. Neo or MBA-MIA
17622	Fill	17615			Skeleton. Crouched burial. N/S orientation, poor condition.		
17623	Group				Burial Group. Group for crouched burial [17615] sk1622		



<b>Trench 177</b>							
General description					Orientation		N-S
Trench devoid of archaeology. Trench contains a reworked river terrace gravel - head deposit with ploughsoil formed in the top of the later.					Length (m)		30
					Width (m)		2
					Avg. depth (m)		0.6
Context No.	Type	Fill Of	Width (m)	Depth (m)	Description	Finds	Date
17700	Layer			0.3	Ploughsoil. Dark brownish grey, sandy silt		
17701	Layer			0.19	Other Layer. Dark orangish brown, clayey sand		
17702	Layer			0.05	Natural. Mid orange brown, clayey sand, patches of gravel		
17703	Cut				Natural Feature. Unexcavated natural feature		
17704	Layer			0.1	Subsoil. Soft light reddish brown and light greyish brown sandy clayey silt. Subsoil.		
<b>Trench 178</b>							
General description					Orientation		E-W
Trench revealed 4 ditches and 1 pit. Trench contains a possible head deposit covered by ploughsoil.					Length (m)		30
					Width (m)		2
					Avg. depth (m)		0.62
Context No.	Type	Fill Of	Width (m)	Depth (m)	Description	Finds	Date
17800	Layer			0.32	Ploughsoil. Dark grey brown, friable silty clay		
17801	Layer			0.3	Subsoil. Mid orange brown, friable silty clay		
17802	Layer			0.2	Other Layer. Mid grey brown, friable silty clay, small pebbles patches	FC, Flint	
17803	Cut		0.55	0.1	Ditch. Shallow linear feature, u-shaped profile.		
17804	Fill	17803	0.55	0.1	Secondary Fill. Dark reddish brown silty sand.	Pot	IA
17805	Cut		0.58	0.16	Ditch. Shallow linear feature, oriented NE-SW.	FC	
17806	Fill	17805	0.58	0.16	Secondary Fill. Light greyish brown silty sand with small black iron? inclusions.	Pot	c 1100-1250?
17807	Cut		1.14	0.4	Pit. Sub circular pit, sheer sides.		
17808	Fill	17807	1.14	0.15	Secondary Fill. Top fill of pit. Mid-pale greyish brown silty clay.	FC, Pot	IA

17809	Fill	17807	1.15	0.1	Secondary Fill. Mid-dark grey, moderately charcoal and ceramic rich	Pot	IA
17810	Fill	17807	1.1	0.1	Secondary Fill. Mid greyish orange silty clay.		
17811	Fill		1.15	0.24	Secondary Fill. Mid greyish brown silty clay	FC, Pot	IA
17812	Layer				Natural. Dark brownish red sandy clay with gravel. Head deposit		
17813	Cut		0.3	0.1	Ditch. Truncated ditch base, originally excavated as terminus. Same as [17815] and [17818].		
17814	Fill	17813	0.3	0.1	Primary Fill. Pale greyish yellow silty sand, firm-hard compaction.		
17815	Cut		0.6	0.3	Ditch. Continuation of ditch 17813, oriented NE-SW.	FC	
17816	Fill	17815	0.3	0.16	Secondary Fill. Pale-mid grey silty clay with occasional-regular ceramic inclusions.		
17817	Fill	17815	0.6	0.15	Secondary Fill. Mid-dark reddish brown silty clay with occasional ceramic inclusions.	Pot	MBA-MIA
17818	Cut		0.5	0.2	Ditch. Probable continuation of cut [17813] + [17815] visible in oblique section against bulk.		
17819	Fill	17818	0.5	0.2	Secondary Fill. Mid-dark reddish brown silty clay layer forming fill of [17818]. Extends beyond cut to the east, overlying fill (17821) of cut [17820].		
17820	Cut		1.2	0.28	Ditch. Straight ditch oriented NE-SW.		
17821	Fill	17820	1.2	0.28	Secondary Fill. Mid-pale brownish grey silty clay.	FC, Pot	MBA-MIA

**Trench 179**

General description					Orientation	N-S	
Trench revealed 1 linear feature at south end. Consists of plough soil overlying sub soil overlaying colluvial overlaying 2 gravel deposits and natural					Length (m)	30	
					Width (m)	6	
					Avg. depth (m)	1.65	
Context No.	Type	Fill Of	Width (m)	Depth (m)	Description	Finds	Date
17900	Layer			0.33	Ploughsoil. Mid buff brown silt w/trace clay,		

					very firm. Rare inclusions chalk, small pebbles and charcoal. Boundary clear se end, more diffuse nw.		
17901	Layer			0.35	Subsoil. Mid buff brown silt, slight clayey w/trace sand. V rare inclusions chalk and small stones up to 1cm. Firm. Boundary clear.		
17902	Layer			1.72	Natural. Thanet sand. Pale olive grey with yellow banding and mottling.		
17903	Layer			0.22	Colluvial Layer. Mid reddish brown silty sand, colluvial deposit w/v. Frequent inclusions pebbles, natural and burnt flint. V firm. Thins out slightly to NW side. Boundary clear se, diffuse nw.		
17904	Layer			0.23	Colluvial Layer. Yellowish red sand, mottled w/darker red patches. Common inclusions 10-15% golf ball size stones rounded and angular. Frequent chalk, natural and burnt flint. Firm. Boundary clear.		
17905	Cut		1.18	0.49	Ditch		
17906	Layer			0.14	Other Layer. Gravel head deposit/River terrace. Varying degrees of sand and clay churning throughout. Top of deposit darker greyish red, changing to reddish yellow with greyish yellow streaks toward bottom - bleaching/colour leaching? Ranges from v firm to moderate depending on stone cluster proximity. Boundary clear.		
17907	Layer			0.24	Other Layer. Bright reddish yellow sand with bands of light reddish yellow. Gravel head deposit/River terrace. Slopes concavely between s17900 and 17901. Loose. Pink clay		

					lens at base. Boundary clear.		
17908	Fill	17905	0.2	0.84	Primary Fill. Moderate yellow/grey brown silty clay. Occasional sub angular stones and dark blackish brown streaks.		
17909	Fill	17905	1.17	0.29	Secondary Fill. Mid yellowish grey, clayey silt, moderate. Occasional small sub rounded stones		
17910	Layer				Colluvial Layer. Mid yellowish brown clayey silt, moderate. Hill wash truncated by ditch. Same as 17902		

<b>Trench 180</b>							
General description					Orientation	E-W	
Trench revealed a pit, 2 linears running NE-SW and one linear running N-S. Consists of a ploughsoil covering a sandy gravel Head deposit derived from possible river terrace.					Length (m)	30	
					Width (m)	2	
					Avg. depth (m)	0.4	
Context No.	Type	Fill Of	Width (m)	Depth (m)	Description	Finds	Date
18000	Layer		2.1	0.3	Ploughsoil. Mid brown grey Sandy silty with occasional Stones		
18001	Layer			0.1	Other Layer. Mid orange brown silty sand with rounded pebbles.		
18002	Layer		2.1	0.05	Natural. Mid red orange silty sand with gravel inclusions.		
18003	Layer				Colluvial Layer. Double number of 18002. Moderately friable mid reddish brown silty sand, heavy concentration of small rounded pebbles throughout.		
18004	Cut		0.47	0.19	Ditch. Linear ditch with NE-SW alignment, steep sides leading to a concave U-shaped base.		
18005	Fill	18004	0.47	0.19	Secondary Fill. Light reddish grey silty clay, extremely compact with infrequent small rounded pebbles throughout. Possible worked flint recovered.	Flint	
18006	Cut		0.54	0.19	Ditch. WSW-ENE running linear, steep sides leading to a concave U-shaped base.		

18007	Fill	18006	0.39	0.06	Secondary Fill. Moderately compact dark blue grey silty clay.		
18008	Fill	18006	0.54	0.17	Deliberate Backfill. Moderately friable mid reddish grey sandy clay.		
18009	Cut		7.25	0.72	Pit		
18010	Fill	18009	7.25	0.72	Secondary Fill	Pot, A. Bone	Roman
18011	Cut		1.2	0.22	Ditch. Ditch running N/S. Over machined.		
18012	Fill	18011	1.2	0.22	Secondary Fill. Light white/yellowish brown, silty sand.		

### Trench 181

General description					Orientation	N-S	
Trench revealed a single natural gully. Consisted of ploughsoil overlying Head deposit and river terrace gravel.					Length (m)	30	
					Width (m)	2	
					Avg. depth (m)	0.45	
Context No.	Type	Fill Of	Width (m)	Depth (m)	Description	Finds	Date
18100	Layer		2.1	0.3	Ploughsoil. Mid brown grey Sandy silt		
18101	Layer		2.1	0.1	Other Layer. Mid brown orange silty sand. Occurring only at northern corner of the trench.		
18102	Layer		2.1	0.05	Other Layer. Head deposit. Mid orange red silty sand with gravel patches		
18103	Cut		0.32	0.07	Ditch		
18104	Fill	18103		0.07	Other Fill. Mid greyish brown sandy silt, soft with occasional small rounded pebbles.		

### Trench 182

General description					Orientation	E-W	
Trench revealed a single NE-SW aligned ditch. Consists of ploughsoil and Pleistocene Head deposit derived from possible river terrace.					Length (m)	30	
					Width (m)	2	
					Avg. depth (m)	0.6	
Context No.	Type	Fill Of	Width (m)	Depth (m)	Description	Finds	Date
18200	Layer			0.34	Ploughsoil. Dark brown grey, friable silty clay		
18201	Layer			0.26	Other Layer. Strong brown, friable silty clay, slightly sandy.		
18202	Layer				Natural. Mid red brown, loose sand with occasional gravels		
18203	Cut		1.18	0.3	Ditch		

18204	Fill	18203		0.3	Tertiary Fill. Mid red brown loose silty sand with rare small unsorted sub-rounded gravels	Flint	
<b>Trench 183</b>							
General description					Orientation		N-S
Trench revealed a ditch, a gully and a pit. Consists of ploughsoil covering a Head deposit and possible river terrace gravel and sand.					Length (m)		30
					Width (m)		2
					Avg. depth (m)		0.5
Context No.	Type	Fill Of	Width (m)	Depth (m)	Description	Finds	Date
18300	Layer			0.3	Ploughsoil. Dark brownish grey, sandy silt		
18301	Layer			0.11	Other Layer. Strong brown, clayey sandy silt. Firm. Very rare rounded pebbles.	Pot	IA
18302	Layer			0.06	Other Layer. Red coarse sand. Loose.		
18303	Cut		1.8	0.4	Ditch.		
18304	Fill	18303	1.8	0.4	Secondary Fill. Mid greyish yellow silty sand, firm with occasional charcoal flecks and CBM fragments.	Flint, Pot	MIA
18305	Cut		0.68	0.2	Ring Gully.		
18306	Fill	18305	0.68	0.2	Other Fill. Light greyish brown silty sand, firm, no inclusion visible.		
18307	Cut			0.4	Pit		
18308	Fill	18307		0.4	Secondary Fill. Mid brownish grey sandy silt, soft with occasional rounded pebbles and sub-angular flint fragments.	Pot	IA
<b>Trench 184</b>							
General description					Orientation		N-S
Trench revealed 1 large ditch running NW-SE and 2 running SW-NW. Trench consists of ploughsoil that covers Holocene colluvium in which archaeological features are cut in. Pleistocene Head deposit and river gravel recorded in the lower section.					Length (m)		30
					Width (m)		6
					Avg. depth (m)		0.4
Context No.	Type	Fill Of	Width (m)	Depth (m)	Description	Finds	Date
18400	Layer			0.32	Ploughsoil. Dark greyish brown, friable silty clay		
18401	Layer			0.08	Colluvial Layer. Mid reddish grey, friable silty clay	FC	
18402	Layer				Other Layer. Mid reddish grey (strong brown) loose sandy silt with pebble patches.		

18403	Void						
18404	Void						
18405	Void						
18406	Void						
18407	Void						
18408	Layer			0.21	Other Layer. Mid brown clayey sandy silt. Compact. Abundant poorly sorted pebbles.		
18409	Layer			0.4	Other Layer. Red coarse sand. Loose.		
18410	Layer			1	Other Layer. Dark reddish coarse sand with silt. Moderately sorted rounded pebbles. Compact.		
18411	Layer				Natural. Olive fine sand. Loose.		
18412	Cut		0.75	0.35	Ditch. Possible ditch. Recorded only in geoarch section. Moderately sloping sides and rounded base. West/East orientation.		
18413	Fill	18412	0.75	0.05	Tertiary Fill. Mid brown silt. Firm		
18414	Fill	18412	0.75	0.3	Secondary Fill. Pale brown silt. Firm		
18415	Layer				Other Layer. VOIDED		
18416	Cut		2.15	0.43	Ditch		
18417	Fill	18416	2.15	0.4	Secondary Fill. mid greyish brown silty clay	FC, Flint, Pot, A. Bone	MIA
18418	Fill	18416	1.45	0.1	Tertiary Fill. Orangey brown silty clay		
18419	Cut			0.24	Pit		
18420	Fill	18419		0.24	Deliberate Backfill. Reddish brown silty clay	Pot	MBA-MIA
18421	Cut		0.88	0.21	Ditch		
18422	Fill	18421	0.88	0.21	Secondary Fill. Reddish brown silty clay	Pot	LBA-EIA

### Trench 185

General description					Orientation	N-S	
Trench revealed several ditches and discrete features including pits. Trench comprised ploughsoil covering a possible reworked river terrace gravel - Head deposit.					Length (m)	30	
					Width (m)	2	
					Avg. depth (m)	0.44	
Context No.	Type	Fill Of	Width (m)	Depth (m)	Description	Finds	Date
18500	Layer			0.3	Ploughsoil. Dark greyish brown clayey silt.		
18501	Layer			0.14	Subsoil. Mid reddish brown silty clay with very rare pebbles.		

18502	Layer				Natural. Mid reddish brown sandy clay and gravel.		
18503	Cut		0.7	0.11	Pit		
18504	Fill	18503	0.7	0.11	Primary Fill. Compact, light brownish grey, clay silt, mod small subangular stones		
18505	Cut		0.45	0.14	Pit		
18506	Fill	18505	0.45	0.14	Primary Fill. Compact, light brownish grey, clay silt, frequent small subangular stones, v. Occ. Charcoal		
18507	Cut		0.48	0.21	Pit		
18508	Fill	18507	0.48	0.21	Primary Fill. Compact, med brownish grey, clay silt, mod flecks of CBM, occ charcoal flecks	Pot	MBA-MIA
18509	Cut		0.47	0.24	Pit		
18510	Fill	18509	0.47	0.24	Primary Fill. Compact, med brownish grey, clay silt, frequent medium rounded stones and pea gravel at base		
18511	Cut		0.35	0.11	Pit		
18512	Fill	18511	0.35	0.11	Primary Fill. Compact, medium brownish grey, clay silt, moderate small sub-rounded stones		
18513	Cut		1.07	0.42	Ditch		
18514	Fill	18513	1.07	0.42	Primary Fill. Firm, mid greyish brown silty clay		
18515	Fill	18513	0.65	0.17	Primary Fill. Firm, light greyish brown, silty clay	Pot, FC, Flint	c 1050-1200?
18516	Cut		1.06	0.27	Ditch		
18517	Fill	18516	1.06	0.27	Primary Fill. Compact, medium brownish grey, clay silt, moderate small rounded stones, very occasional CBM fragments and charcoal flecks	FC	
18518	Cut		1.5	0.29	Ditch		
18519	Fill	18518	1.5	0.29	Primary Fill. Firm, Mid greyish brown, silty clay	FC, A. Bone, Pot	E.Roman
18520	Cut		0.27	0.12	Ditch. Possible Re-cut of [18518]		
18521	Fill	18520	0.27	0.12	Primary Fill. Firm, dark greyish brown silty clay		
18522	Unexc feature		0.83		Ditch. Light grey sandy silt deposit.		

### Trench 186

General description	Orientation	NE-SW
---------------------	-------------	-------



Trench revealed 3 possible postholes aligned E-W, and three linears. Trench located on the top of north facing slope and consists of ploughsoil covering a possible Head deposit.						Length (m)	30
						Width (m)	2
						Avg. depth (m)	0.36
Context No.	Type	Fill Of	Width (m)	Depth (m)	Description	Finds	Date
18600	Layer			0.28	Ploughsoil. Dark greyish brown clayey silt.		
18601	Layer			0.08	Other Layer. Mid reddish brown silty clay. Possible colluvium. Recorded in patches at the top of the gravel.		
18602	Layer				Other Layer. Mid reddish brown sandy clay and gravel. Head deposit.		
18603	Cut		0.64	0.2	Ditch. NW-SE linear ditch		
18604	Fill	18603	0.2	0.64	Secondary Fill. Light greyish brown sandy silt, soft with moderate medium stones.		
18605	Cut		1.37	0.2	Ditch. Truncated by 18613		
18606	Fill	18605	1.37	0.2	Primary Fill. Mid orange brown, silty sand. Frequent stone inclusions.	Pot	MBA-MIA
18607	Cut		0.27	0.06	Posthole. Shallow posthole orientated NE-SW		
18608	Fill	18607	0.27	0.06	Primary Fill. Light brownish silty clay with fee inclusions		
18609	Cut		0.25	0.04	Posthole. Shallow posthole over excavated		
18610	Fill	18609	0.26	0.04	Primary Fill. Mid greyish brown, silty clay with rare rounded stones		
18611	Cut		0.18	0.07	Posthole		
18612	Fill	18611	0.18	0.07	Primary Fill. Mid greyish brown, silty clay no inclusions		
18613	Cut		0.69	0.35	Ditch		
18614	Fill	18613	0.4	0.18	Secondary Fill. Light whitish brown, silty sand.		
18615	Fill	18613	0.61	0.17	Tertiary Fill. Dark greyish brown, silty sand.		
18616	Cut		1.32	0.33	Natural Feature. Linear natural feature.		
<b>Trench 187</b>							
General description						Orientation	NE-SW
Trench revealed 1 large pit. Consists of Ploughsoil overlaying a fine brickearth-like deposit and gravelly Head deposit with frequent clusters/bands of stones Inc flint.						Length (m)	30
						Width (m)	2
						Avg. depth (m)	0.6
Context No.	Type	Fill Of	Width (m)	Depth (m)	Description	Finds	Date

18700	Layer				Natural. Light yellowish brown, slightly gravel, clayey sand.		
18701	Layer				Subsoil. Mid orangish brown, clayey silt. Frequent small/med size stones and flint		
18702	Layer				Ploughsoil. Dark reddish brown, sandy silt. Frequent small stones		
18703	Layer			0.16	Colluvial Layer. Mid yellowish brown clayey silt with very rare rounded to subangular pebbles. Compact.		
18704	Layer			0.17	Other Layer. Dark red sandy clay with abundant rounded pebbles. Compact.		
18705	Void						
18706	Cut		1.5	0.38	Pit. Sub circular, continues beyond L.O.E. Gradual concave sides, base unknown as not bottomed.		
18707	Fill	18706	1.5	0.38	Secondary Fill. Single fill. Firm mid greyish brown. Silty clay, occ small-med stones.		

### Trench 188

General description					Orientation	E-W	
Trench devoid of archaeology. Subsoil appears to vary in depth across the trench, suggesting an uneven surface					Length (m)	30	
					Width (m)	2	
					Avg. depth (m)	0.64	
Context No.	Type	Fill Of	Width (m)	Depth (m)	Description	Finds	Date
18800	Layer			0.35	Ploughsoil. Dark brownish grey, sandy silt		
18801	Layer			0.12	Subsoil. Mid orange brown, clayey sand		
18802	Layer			0.06	Natural. Pale brown, clayey sand, patches of gravel		

### Trench 189

General description					Orientation	N-S	
Trench devoid of archaeology. Consisted of ploughsoil, 3 layers of colluvium over redeposited Thanet sand with convoluted bedding. Then Natural Thanet sand.					Length (m)	30	
					Width (m)	6	
					Avg. depth (m)	0.54	
Context No.	Type	Fill Of	Width (m)	Depth (m)	Description	Finds	Date
18900	Layer			0.34	Ploughsoil. Mid greyish brown slightly clayey silt		

18901	Layer			0.19	Colluvial Layer. Mid yellowish reddish brown sandy silt		
18902	Layer			0.43	Colluvial Layer. Dark yellowish brown slightly clayey sandy silt.		
18903	Layer			0.42	Colluvial Layer. Dark reddish yellowish brown mottled in places with light yellowish sediment silty sand with occasional areas of clayey sand, possible burrow infill.		
18904	Layer			0.55	Other Layer. Mid yellowish brown mottled with light reddish yellow and light olive sediment. Silty sand. Redeposited Thanet Sand Convoluted bedding structure		
18905	Layer			0.1	Natural. Dark yellowish brown mottled with light grey and mid yellow sediment. Sand		

#### Trench 190

General description					Orientation	NE-SW	
Trench revealed 2 ditches, one NE -SW and one NW-SE. Plough furrows across length of trench.					Length (m)	30	
					Width (m)	2	
					Avg. depth (m)	0.39	
Context No.	Type	Fill Of	Width (m)	Depth (m)	Description	Finds	Date
19000	Layer			0.29	Ploughsoil. Dark greyish brown clayey silt.		
19001	Layer			0.1	Colluvial Layer. Mid reddish brown clayey silt.		
19002	Layer				Other Layer. Mid reddish brown sandy clay and gravel. Head deposit.		
19003	Cut		0.64	0.09	Ditch. Shallow ditch running NE-SW		
19004	Fill	19003	0.64	0.09	Secondary Fill. Mid yellowish brown sandy silt, soft with rare small stones.		
19005	Cut		1.1	0.4	Ditch. Cut of ditch running NW/SE		
19006	Fill	19005	1.12	0.4	Secondary Fill. Mid yellowish brown sandy silt with frequent stone inclusions.	FC	

#### Trench 191

General description					Orientation	NNE-SSW
					Length (m)	30
					Width (m)	2

Trench revealed 4 ditches, natural gully and potential agricultural feature. Consists of ploughsoil overlying colluvium and clayey silt head deposit.					Avg. depth (m)	0.32	
Context No.	Type	Fill Of	Width (m)	Depth (m)	Description	Finds	Date
19100	Layer			0.32	Ploughsoil. Dark greyish brown sandy silt		
19101	Layer			0.3	Colluvial Layer. Mid yellowish brown sandy silt. Deposit occurs only in southern part of the trench.		
19102	Layer				Natural. Light yellowish brown clayey sand. Head deposit		
19103	Cut		1	0.18	Plough Furrow		
19104	Fill	19103	1	0.18	Other Fill. Mid greyish brown silty clay, friable		
19105	Cut		0.5	0.16	Natural Feature		
19106	Fill	19105	0.5	0.16	Other Fill. Mid greyish brown silty clay, friable		
19107	Cut		1.14	0.36	Ditch. 1m section of linear feature. Moderately sloping concave sides. No obvious break of slope at base.		
19108	Fill	19107	1.14	0.36	Secondary Fill. Friable mid orange brown silty sand. 5-10% small to medium gravel inclusions. <5% charcoal. No finds recovered.		
19109	Cut		0.98	0.22	Ditch. Linear feature running E-W. Moderately sloped concave sides with somewhat clear break of slope at base.		
19110	Fill	19109	0.98	0.22	Secondary Fill. Friable mid grey brown silty sand. <5% charcoal inclusions. No finds.	Pot	Roman
19111	Cut		2.4	1.12	Ditch		
19112	Fill	19111	0.83	0.2	Primary Fill. Dark greyish brown gravelly silt, very compact, no inclusion visible.		
19113	Fill	19111	2.4	1.12	Secondary Fill. Mid yellowish brown sandy clay, compact with occasional stone inclusion.	FC, Pot	E.Roman
19114	Cut		0.5	0.32	Ditch. Recut of 19111?		
19115	Fill	19114	0.5	0.32	Secondary Fill. Mid greyish brown sandy clay, moderately compact, no inclusion visible.		

<b>Trench 192</b>							
General description					Orientation		E-W
Trench devoid of archaeology. Consisted of ploughsoil and subsoil overlying the natural geology of clay.					Length (m)		30
					Width (m)		2
					Avg. depth (m)		0.5
Context No.	Type	Fill Of	Width (m)	Depth (m)	Description	Finds	Date
19200	Layer			0.32	Ploughsoil. Dark, grey brown, friable clay		
19201	Layer			0.18	Subsoil. Mid orange brown, friable silty clay		
19202	Layer				Natural. Light grey brown, firm silty clay		
<b>Trench 193</b>							
General description					Orientation		N-S
Trench devoid of archaeology. Consists of ploughsoil and colluvium overlying silty clay head deposit.					Length (m)		30
					Width (m)		2
					Avg. depth (m)		0.35
Context No.	Type	Fill Of	Width (m)	Depth (m)	Description	Finds	Date
19300	Layer			0.35	Ploughsoil. Dark greyish brown clayey silt.		
19301	Layer			0.14	Colluvial Layer. Mid yellowish brown clayey silt with rare rounded pebbles.		
19302	Layer				Natural. Mid reddish brown silty clay with rare rounded pebbles.		
19303	Cut		0.96	0.45	Natural Feature. Mid greyish brown clayey silt, soft with rare rounded pebbles.		
<b>Trench 194</b>							
General description					Orientation		NE-SW
Trench revealed two ditches. Consists of ploughsoil and colluvium overlying natural geology of silty clay.					Length (m)		30
					Width (m)		2
					Avg. depth (m)		0.29
Context No.	Type	Fill Of	Width (m)	Depth (m)	Description	Finds	Date
19400	Layer			0.29	Ploughsoil. Dark grey clayey silt		
19401	Layer			0.23	Colluvial Layer. Light yellowish brown clayey silt.		
19402	Layer				Natural. Head deposit. Mid reddish brown sandy clay with gravel inclusions		
19403	Cut		0.39	0.39	Ditch. N-S		
19404	Fill	19403	0.39	0.39	Secondary Fill. Soft light brownish grey sandy silt.		

19405	Cut		0.5	0.3	Ditch		
19406	Fill	19405	0.5	0.3	Secondary Fill. Mid greyish brown clayey silt, no inclusion visible, frequent bioturbation traces.		
<b>Trench 195</b>							
General description					Orientation	N-S	
Trench devoid of archaeology. Consists of ploughsoil and colluvium overlying natural geology of silty clay.					Length (m)	30	
					Width (m)	2	
					Avg. depth (m)	0.26	
Context No.	Type	Fill Of	Width (m)	Depth (m)	Description	Finds	Date
19500	Layer			0.26	Ploughsoil. Dark brownish grey clayey silt, soft with moderate sub-angular flint fragments and rounded pebbles.		
19501	Layer			0.2	Colluvial Layer. Mid yellowish brown clayey silt, soft with rare rounded pebbles.		
19502	Layer				Natural. Head deposit. Mid reddish brown silty clay with occasional patches of gravel, soft.		
19503	Void						
<b>Trench 196</b>							
General description					Orientation	E-W	
Trench revealed 5 ditches, one potential pit and natural feature. Consists of ploughsoil and colluvium overlying natural geology of silty clay.					Length (m)	30	
					Width (m)	2	
					Avg. depth (m)	0.25	
Context No.	Type	Fill Of	Width (m)	Depth (m)	Description	Finds	Date
19600	Layer		2	0.25	Ploughsoil. Dark Greyish Brown loam.		
19601	Layer		2		Natural. Mid orangish brown moderately compact silty clay with occasional patches of gravel.		
19602	Cut		1.08	0.46	Ditch		
19603	Fill	19602	1.08	0.46	Secondary Fill. Mid greyish brown sandy silt, friable.	Flint, Pot	LBA-MIA
19604	Cut		1.4	0.46	Ring Ditch		
19605	Fill	19604	1.4	0.46	Secondary Fill. Mid greyish brown sandy silt, friable	FC, Pot, A. Bone	MBA-MIA
19606	Cut		0.62	0.4	Ditch		
19607	Fill	19606	0.62	0.4	Secondary Fill. Mid grey-brown sandy silt, friable	Flint, Pot	E.Roman

19608	Cut		0.3	0.29	Ditch		
19609	Fill	19608	0.3	0.29	Secondary Fill. Mid greyish brown sandy silt, friable.	Pot	MBA-MIA
19610	Cut				Natural Feature. Tree throw		
19611	Layer			0.09	Colluvial Layer. Light yellowish brown clayey silt with rare small pebbles.		
19612	Cut		1.18	0.42	Ditch		
19613	Fill	19612	1.1	0.15	Primary Fill. Mid greyish brown sandy silt, compact	Flint	Early Neolithic
19614	Fill	19612	1.18	0.27	Secondary Fill. Light yellowish brown sandy silt, friable.		
19615	Cut		0.97	0.39	Ditch		
19616	Fill	19615	0.98	0.07	Primary Fill. Light grey clayey sand with occasional stones.		
19617	Fill	19615	0.97	0.53	Secondary Fill. Mid greyish brown sandy silt with moderate gravel inclusion.		

### Trench 197

General description					Orientation	N-S
Trench revealed single ditch and potential posthole. Consists of ploughsoil overlying colluvium and silty clay head deposit.					Length (m)	30
					Width (m)	2
					Avg. depth (m)	0.3

Context No.	Type	Fill Of	Width (m)	Depth (m)	Description	Finds	Date
19700	Layer			0.3	Ploughsoil. Dark brownish grey clayey silt with occasional rounded pebbles and sub-angular flint fragments.		
19701	Layer				Natural. Head deposit. Mid reddish brown silty clay with rare gravel inclusion.		
19702	Cut			0.56	Ditch		
19703	Fill	19702			Secondary Fill. Mid brownish grey with orange mottling silty clay, soft.	A. Bone	
19704	Cut		0.3	0.09	Posthole		
19705	Fill	19704	0.3	0.09	Deliberate Backfill. Mid greyish brown clayey silt, compact.		
19706	Layer			0.3	Colluvial Layer. Mid greyish brown clayey silt with rare rounded pebbles.		

### Trench 198

General description					Orientation	NE-SW
---------------------	--	--	--	--	-------------	-------

Trench revealed ditch, potential ditch terminus and quarry pit. Consists of ploughsoil and colluvium overlying natural geology of silty clay.						Length (m)	30
						Width (m)	2
						Avg. depth (m)	0.3
Context No.	Type	Fill Of	Width (m)	Depth (m)	Description	Finds	Date
19800	Layer		2	0.3	Ploughsoil. Dark brownish grey clayey silt		
19801	Layer			0.19	Colluvial Layer. Mid yellowish brown clayey silt with rare rounded pebbles.		
19802	Layer				Natural. Medium yellowish to reddish silty clay with patches of yellow silty sand - possible head deposit.		
19803	Void						
19804	Cut		1.38	0.74	Pit. Quarry pit		
19805	Cut	19805			Ditch		
19806	Cut		0.38	0.52	Ditch. Ditch terminus, no finds retrieved		
19807	Fill	19806	0.38	0.52	Secondary Fill. Mid brown sandy clay with occasional rounded small pebbles.		
19808	Fill	19804	1.07	0.14	Secondary Fill. Dark brownish grey clayey silt with mixed patches of yellow sand, moderately compact.		
19809	Fill	19804	0.92	0.42	Secondary Fill. Mid brownish grey sandy silt, moderately compact.		
19810	Fill	19805	0.9	0.34	Secondary Fill. Mid greyish brown silty clay, moderately compact with occasional chalk flecks and small sub-angular stones.		
19811	Void						
19812	Fill	19804	0.76	0.47	Primary Fill. Mid yellowish brown silty sand, moderately compact with gravel inclusion.		
<b>Trench 199</b>							
General description						Orientation	N-S
Trench devoid of archaeology. Consists of ploughsoil and colluvium overlying natural geology of silty clay.						Length (m)	30
						Width (m)	2
						Avg. depth (m)	0.3
Context No.	Type	Fill Of	Width (m)	Depth (m)	Description	Finds	Date
19900	Layer			0.3	Ploughsoil. Mid brownish grey clayey silt, soft with moderate sub-angular flint		



					fragments and rounded pebbles.		
19901	Layer			0.2	Colluvial Layer. Mid yellowish brown clayey silt, soft with rare rounded pebbles.		
19902	Layer				Natural. Head deposit. Mid reddish brown silty clay with occasional rounded pebbles and flint fragments.		

<b>Trench 200</b>							
General description					Orientation		E-W
Trench consists of ploughsoil overlying colluvial layer and silty clay head deposit. Trench devoid of archaeology.					Length (m)		30
					Width (m)		2
					Avg. depth (m)		0.32
Context No.	Type	Fill Of	Width (m)	Depth (m)	Description	Finds	Date
20000	Layer			0.32	Ploughsoil. Dark grey clayey silt		
20001	Layer			0.19	Colluvial Layer. Light greyish brown clayey silt		
20002	Layer				Natural. Head deposit. Mid reddish brown sandy clay with gravel inclusions		
<b>Trench 201</b>							
General description					Orientation		N-S
Devoid of archaeology. Consists of ploughsoil overlying colluvium and fine grained head deposit.					Length (m)		30
					Width (m)		2
					Avg. depth (m)		0.25
Context No.	Type	Fill Of	Width (m)	Depth (m)	Description	Finds	Date
20100	Layer		2	0.22	Ploughsoil. Dark greyish brown sandy silt		
20101	Layer		2	0.18	Colluvial Layer. Mid yellowish brown sandy silt		
20102	Layer				Natural. Light yellowish to reddish brown sandy clay with patches of rounded to sub angular pebbles. Fine grained head deposit		
<b>Trench 202</b>							
General description					Orientation		W-E
Trench revealed single small pit. Consists of ploughsoil and subsoil overlying natural geology of silty clay.					Length (m)		30
					Width (m)		2

						Avg. depth (m)	0.29
Context No.	Type	Fill Of	Width (m)	Depth (m)	Description	Finds	Date
20200	Layer			0.29	Ploughsoil. Dark grey clayey silt		
20201	Layer			0.19	Colluvial Layer. Light greyish brown clayey silt.		
20202	Layer				Natural. Light reddish brown sandy clay		
20203	Cut		1.41	0.38	Tree Throw. Irregular in plan. Compact dark brownish grey mixed with mid yellowish brown clayey silt.		
20204	Cut	20204	0.38	0.34	Pit		
20205	Fill	20204	0.38	0.34	Deliberate Backfill. Mid greyish brown mottled with mid reddish brown silty clay, moderately compact, no inclusion visible.		

### Trench 203

General description	Orientation	N-S
Trench consists of ploughsoil and colluvium overlying silty clay head deposit.	Length (m)	30
	Width (m)	2
	Avg. depth (m)	0.3

Context No.	Type	Fill Of	Width (m)	Depth (m)	Description	Finds	Date
20300	Layer			0.3	Ploughsoil. Dark brownish grey clayey silt		
20301	Layer			0.19	Colluvial Layer. Mid greyish brown clayey silt		
20302	Layer				Natural. Mid reddish brown silty clay with gavel inclusion.		
20303	Void						

### Trench 204

General description	Orientation	E-W
Trench devoid of archaeology. Consists of ploughsoil and colluvium overlying natural geology of silty clay.	Length (m)	30
	Width (m)	2
	Avg. depth (m)	0.32

Context No.	Type	Fill Of	Width (m)	Depth (m)	Description	Finds	Date
20400	Layer		2	32	Ploughsoil. Dark brownish grey clayey silt with occasional rounded pebbles and flint fragments.		
20401	Layer			20	Colluvial Layer. Mid yellowish brown clayey silt with rare rounded pebbles.		

20402	Layer				Natural. Light reddish brown clayey silt - possible head deposit		
<b>Trench 205</b>							
General description					Orientation	N-S	
Trench devoid of archaeology. Consists of ploughsoil and colluvium overlying a clayey sand head deposit.					Length (m)	30	
					Width (m)	2	
					Avg. depth (m)	0.26	
Context No.	Type	Fill Of	Width (m)	Depth (m)	Description	Finds	Date
20500	Layer			0.26	Ploughsoil. Dark brownish grey clayey silt		
20501	Layer			0.16	Colluvial Layer. Light greyish brown clayey silt		
20502	Layer				Natural. Mid reddish brown clayey sand with frequent gravel inclusions.		
20503	Cut		1.3	0.4	Tree Throw. Mid greyish brown clayey silt, soft.		
<b>Trench 206</b>							
General description					Orientation	E-W	
Trench devoid of archaeology. Consists of ploughsoil and colluvium overlying sandy clay head deposit.					Length (m)	30	
					Width (m)	2	
					Avg. depth (m)	0.3	
Context No.	Type	Fill Of	Width (m)	Depth (m)	Description	Finds	Date
20600	Layer		2	0.25	Ploughsoil. Dark greyish brown clayey silt with occasional rounded pebbles.		
20601	Layer		2	0.17	Colluvial Layer. Light greyish brown clayey silt		
20602	Layer				Natural. Mid reddish brown sandy clay with occasional gravel inclusion.		
20603	Cut		0.6	0.1	Natural Feature. Light greyish brown clayey silt, rare stone inclusion.		
<b>Trench 207</b>							
General description					Orientation	NW-SE	
Trench consists of ploughsoil and colluvium overlying a natural geology of silty clay. One potential posthole against east bulk, one natural feature in northern half.					Length (m)	30	
					Width (m)	2	
					Avg. depth (m)	0.22	
Context No.	Type	Fill Of	Width (m)	Depth (m)	Description	Finds	Date
20700	Layer			0.22	Ploughsoil. Dark grey clayey silt		

20701	Layer			0.18	Colluvial Layer. Light greyish brown clayey silt		
20702	Layer				Natural. Head deposit. Light reddish brown sandy clay		
20703	Cut		0.48	0.4	Posthole		
20704	Fill	20703	0.48	0.4	Secondary Fill. Friable mid grey brown silty sand. <5% charcoal, no finds.		
20705	Cut				Natural Feature. Mid greyish brown sandy silt.		

### Trench 208

General description					Orientation	E-W	
Trench consists of ploughsoil and colluvium overlying sandy clay head deposit. Trench revealed single ditch.					Length (m)	30	
					Width (m)	2	
					Avg. depth (m)	0.32	
Context No.	Type	Fill Of	Width (m)	Depth (m)	Description	Finds	Date
20800	Layer			0.32	Ploughsoil. Dark grey clayey silt.		
20801	Layer			0.23	Colluvial Layer. Light yellowish brown clayey silt		
20802	Layer				Natural. Head deposit. Mid reddish brown sandy clay with gravel inclusions.		
20803	Cut		0.37	0.26	Ditch. NE-SW		
20804	Fill	20803	0.37	0.26	Secondary Fill. Soft light brownish grey clayey silt.		
20805	Cut		1.31	0.23	Tree-Throw hole. Mid brownish grey sandy silt, moderately compact.		

### Trench 209

General description					Orientation	NW-SE	
Trench consists of ploughsoil and colluvium overlying sandy clay head deposit. Trench devoid of archaeology.					Length (m)	30	
					Width (m)	2	
					Avg. depth (m)	0.22	
Context No.	Type	Fill Of	Width (m)	Depth (m)	Description	Finds	Date
20900	Layer			0.23	Ploughsoil. Dark grey clayey silt		
20901	Layer			0.13	Colluvial Layer. Light greyish brown clayey silt.		
20902	Layer				Natural. Light reddish brown sandy clay.		

### Trench 210

General description					Orientation	E-W
					Length (m)	30

Trench consists of ploughsoil overlying clayey sand head deposit. Trench devoid of archaeology.						Width (m)	2
						Avg. depth (m)	0.3
Context No.	Type	Fill Of	Width (m)	Depth (m)	Description	Finds	Date
21000	Layer			0.3	Ploughsoil. Dark grey clayey silt		
21001	Layer			0.08	Colluvial Layer. Mid yellowish brown clayey silt.		
21002	Layer				Natural. Mid reddish brown clayey sand.		
<b>Trench 211</b>							
General description						Orientation	NE-SW
Trench consists of ploughsoil and colluvium overlying a silty gravel head deposit. Trench devoid of archaeology.						Length (m)	30
						Width (m)	2
						Avg. depth (m)	0.37
Context No.	Type	Fill Of	Width (m)	Depth (m)	Description	Finds	Date
21100	Layer			0.37	Ploughsoil. Dark grey clayey silt		
21101	Layer			0.1	Colluvial Layer. Light greyish brown clayey silt		
21102	Layer				Natural. Head deposit. Dark reddish brown silty gravel with sandy clay patches.		
<b>Trench 212</b>							
General description						Orientation	NW-SE
Trench devoid of archaeology. Consists of ploughsoil and colluvium overlying sandy clay head deposit.						Length (m)	30
						Width (m)	2
						Avg. depth (m)	0.3
Context No.	Type	Fill Of	Width (m)	Depth (m)	Description	Finds	Date
21200	Layer			0.3	Ploughsoil. Dark grey clayey silt		
21201	Layer			0.12	Colluvial Layer. Light greyish brown clayey silt.		
21202	Layer				Natural. Mid reddish brown sandy clay		
<b>Trench 213</b>							
General description						Orientation	NE-SW
Trench revealed single ditch. Consists of ploughsoil and colluvial layer overlying sandy clay head deposit.						Length (m)	30
						Width (m)	2
						Avg. depth (m)	0.33
Context No.	Type	Fill Of	Width (m)	Depth (m)	Description	Finds	Date
21300	Layer			0.33	Ploughsoil. Dark grey clayey silt		

21301	Layer			0.19	Colluvial Layer. Light yellowish brown clayey silt		
21302	Layer				Natural. Mid reddish brown sandy clay		
21303	Cut		1.18	0.35	Ditch. 1m section of linear feature. Moderately sloped sides with mostly flat base. Clear break of slope at base.		
21304	Fill	21303	1.18	0.35	Secondary Fill. Friable mid orange grey silty clay. <5% small gravel inclusions. Some finds recovered.	Pot, Flint	c 1270-1350

### Trench 214

General description					Orientation	W-E	
Trench devoid of archaeology. Consists ploughsoil and colluvium overlying silty clay head deposit.					Length (m)	30	
					Width (m)	2	
					Avg. depth (m)	0.3	
Context No.	Type	Fill Of	Width (m)	Depth (m)	Description	Finds	Date
21400	Layer			0.31	Ploughsoil. Dark brownish grey clayey silt, soft with moderate sub-angular flint fragments and rounded pebbles.		
21401	Layer			0.18	Colluvial Layer. Mid yellowish brow clayey silt, soft with rare rounded pebbles.		
21402	Layer				Natural. Head deposit. Mid reddish to yellowish silty clay with frequent patches of gravel.		

### Trench 215

General description					Orientation	NNE-SSW	
Trench devoid of archaeology. Consists of ploughsoil and colluvium overlying silty clay head deposit.					Length (m)	30	
					Width (m)	2	
					Avg. depth (m)	0.25	
Context No.	Type	Fill Of	Width (m)	Depth (m)	Description	Finds	Date
21500	Layer			0.25	Ploughsoil. Dark brownish clayey silt, soft with moderate sub-angular flint fragments and rounded pebbles.		
21501	Layer			0.25	Colluvial Layer. Mid yellowish brow clayey silt, soft with rare rounded pebbles.		
21502	Layer				Natural. Mid reddish to yellowish brown silty clay		

					with frequent patches of gravel.		
<b>Trench 216</b>							
General description					Orientation	E-W	
Trench revealed single ditch terminus. Consists of ploughsoil and colluvium overlying a silty sand head deposit.					Length (m)	30	
					Width (m)	2	
					Avg. depth (m)	0.32	
Context No.	Type	Fill Of	Width (m)	Depth (m)	Description	Finds	Date
21600	Layer			0.32	Ploughsoil. Dark grey clayey silt		
21601	Layer			0.12	Colluvial Layer. Light greyish brown clayey silt		
21602	Layer				Natural. Light brownish yellow and red silty sand with frequent gravel inclusions		
21603	Cut		1.35	0.64	Ditch		
21604	Fill	21603	1.35	0.5	Primary Fill. Dark brownish grey sandy gravel, moderately compact.		
21605	Fill	21603	1.35	0.12	Secondary Fill. Mid greyish brown sandy clayey silt, moderately compact with occasional sub-angular pebbles.		
<b>Trench 217</b>							
General description					Orientation	NW-SE	
Trench consists of ploughsoil and colluvium overlying sandy clay head deposit. Trench devoid of archaeology.					Length (m)	30	
					Width (m)	2	
					Avg. depth (m)	0.3	
Context No.	Type	Fill Of	Width (m)	Depth (m)	Description	Finds	Date
21700	Layer			0.29	Ploughsoil. Dark grey clayey silt		
21701	Layer			0.15	Colluvial Layer. Light yellowish brown clayey silt		
21702	Layer				Natural. Head deposit. Mid reddish brown sandy clay		
<b>Trench 218</b>							
General description					Orientation	E-W	
Trench devoid of archaeology. Consists of ploughsoil and colluvium overlying sandy clay head deposit.					Length (m)	30	
					Width (m)	2	
					Avg. depth (m)	0.3	
Context No.	Type	Fill Of	Width (m)	Depth (m)	Description	Finds	Date

21800	Layer			0.33	Ploughsoil. Dark grey clayey silt		
21801	Layer			0.14	Colluvial Layer. Light greyish brown clayey silt		
21802	Layer				Natural. Mid reddish brown sandy clay		
<b>Trench 219</b>							
General description					Orientation	NNE-SSW	
Trench devoid of archaeology. Consists of ploughsoil and colluvial layer overlying sandy clay head deposit.					Length (m)	30	
					Width (m)	2	
					Avg. depth (m)	0.25	
Context No.	Type	Fill Of	Width (m)	Depth (m)	Description	Finds	Date
21900	Layer			0.25	Ploughsoil. Dark brownish grey clayey silt, soft with moderate sub-angular flint fragments and rounded pebbles.		
21901	Layer			0.25	Colluvial Layer. Mid yellowish brow clayey silt, soft with rare rounded pebbles.		
21902	Layer				Natural. Head deposit. Mid reddish brown sandy clay with frequent patches of gravel.		
<b>Trench 220</b>							
General description					Orientation	WNW-ESE	
Trench devoid of archaeology. Consists of ploughsoil and colluvial layer overlying sandy clay head deposit.					Length (m)	30	
					Width (m)	2	
					Avg. depth (m)	0.3	
Context No.	Type	Fill Of	Width (m)	Depth (m)	Description	Finds	Date
22000	Layer			0.3	Ploughsoil. Mid brownish grey clayey silt, soft with moderate sub-angular flint fragments and rounded pebbles.		
22001	Layer			0.2	Colluvial Layer. Mid yellowish brow clayey silt, soft with rare rounded pebbles.		
22002	Layer				Natural. Head deposit. Mid yellowish brown sandy clay with occasional patches of gravel.		
<b>Trench 221</b>							
General description					Orientation	N-S	
Trench devoid of archaeology. Consists of ploughsoil and colluvium overlying silty sand head deposit.					Length (m)	30	
					Width (m)	2	



						Avg. depth (m)	0.3
Context No.	Type	Fill Of	Width (m)	Depth (m)	Description	Finds	Date
22100	Layer			0.3	Ploughsoil. Dark brownish grey clayey silt with occasional sub-angular flint fragments and rounded pebbles.		
22101	Layer			0.24	Colluvial Layer. Mid yellowish brown clayey silt with rare rounded pebbles.		
22102	Layer				Natural. Mid red and yellow silty sand with frequent patches of gravel.		
<b>Trench 222</b>							
General description						Orientation	NW-SE
Trench consists of ploughsoil and colluvium overlying sandy clay head deposit. Trench devoid of archaeology.						Length (m)	30
						Width (m)	2
						Avg. depth (m)	0.3
Context No.	Type	Fill Of	Width (m)	Depth (m)	Description	Finds	Date
22200	Layer			0.3	Ploughsoil. Dark grey clayey silt		
22201	Layer			0.25	Colluvial Layer. Light greyish brown clayey silt		
22202	Layer				Natural. Mid reddish brown sandy clay		
<b>Trench 223</b>							
General description						Orientation	NE-SW
Trench revealed single ditch. Consists of ploughsoil and colluvium overlying sandy clay head deposit.						Length (m)	30
						Width (m)	2
						Avg. depth (m)	0.3
Context No.	Type	Fill Of	Width (m)	Depth (m)	Description	Finds	Date
22300	Layer			0.3	Ploughsoil. Dark grey clayey silt		
22301	Layer			0.29	Colluvial Layer. Light greyish brown clayey silt		
22302	Layer				Natural. Mid reddish brown sandy clay with gravel inclusions		
22303	Cut		0.68	0.61	Ditch. 1m section of linear feature. Moderate/steep concave slopes sides with clear break of slope at base.		
22304	Fill	22303	0.68	0.61	Secondary Fill. Friable mid orange brown silty sand. 5-10% small gravel inclusions. No finds.		

<b>Trench 224</b>							
General description					Orientation		WNW-ESE
Trench devoid of archaeology. Consists of ploughsoil and colluvium layer overlying silty clay head deposit.					Length (m)		30
					Width (m)		2
					Avg. depth (m)		0.26
Context No.	Type	Fill Of	Width (m)	Depth (m)	Description	Finds	Date
22400	Layer			0.26	Ploughsoil. Dark brownish grey clayey silt, soft with moderate sub-angular flint fragments and rounded pebbles.		
22401	Layer			0.23	Colluvial Layer. Mid yellowish brow clayey silt, soft with rare rounded pebbles.		
22402	Layer				Natural. Head deposit. Mid yellowish to reddish brown silty clay with frequent patches of gravel.		
<b>Trench 225</b>							
General description					Orientation		NNE-SSW
Trench devoid of archaeology. Consists of ploughsoil and colluvium overlying silty clay head deposit.					Length (m)		30
					Width (m)		2
					Avg. depth (m)		0.33
Context No.	Type	Fill Of	Width (m)	Depth (m)	Description	Finds	Date
22500	Layer			0.33	Ploughsoil. Dark brownish grey clayey silt, soft with moderate sub-angular flint fragments and rounded pebbles.		
22501	Layer			0.2	Colluvial Layer. Mid yellowish brow clayey silt, soft with rare rounded pebbles.		
22502	Layer				Natural. Head deposit. Mid reddish to yellowish brown silty clay with occasional gravel inclusion and patches of compact yellow silty sand.		
<b>Trench 226</b>							
General description					Orientation		W-E
Trench revealed single pit. Consists of ploughsoil and colluvium overlying sandy clay head deposit.					Length (m)		30
					Width (m)		2
					Avg. depth (m)		0.3
Context No.	Type	Fill Of	Width (m)	Depth (m)	Description	Finds	Date

22600	Layer			0.3	Ploughsoil. Dark brownish grey clayey silt with occasional rounded pebbles and sub-angular flint fragments.		
22601	Layer			0.2	Colluvial Layer. Mid yellowish brown clayey silt with rare rounded pebbles.		
22602	Layer				Natural. Mid reddish to yellowish brown sandy clay with frequent patches of gravel.		
22603	Cut		0.84	0.39	Pit. Small sub circular pit		
22604	Fill	22603	0.84	0.39	Secondary Fill. Mid grey brown sandy clay 1%> stone inclusions		

### Trench 227

General description					Orientation	E-W	
Trench devoid of archaeology. Consists of ploughsoil and colluvium overlying sandy clay head deposit.					Length (m)	30	
					Width (m)	2	
					Avg. depth (m)	0.3	
Context No.	Type	Fill Of	Width (m)	Depth (m)	Description	Finds	Date
22700	Layer			0.32	Ploughsoil. Dark grey clayey silt		
22701	Layer			0.19	Colluvial Layer. Light greyish brown clayey silt		
22702	Layer				Natural. Mid reddish brown sandy clay with gravel.		

### Trench 228

General description					Orientation	NE-SW	
Trench consists of ploughsoil and colluvium overlying sandy clay head deposit. Trench devoid of archaeology.					Length (m)	30	
					Width (m)	2	
					Avg. depth (m)	0.3	
Context No.	Type	Fill Of	Width (m)	Depth (m)	Description	Finds	Date
22800	Layer			0.32	Ploughsoil. Dark grey clayey silt		
22801	Layer			0.12	Colluvial Layer. Light greyish brown clayey silt		
22802	Layer				Natural. Mid reddish brown sandy clay with gravel inclusions		
22803	Cut		0.39	0.06	Natural Feature. Light brownish grey sandy silt		

### Trench 229

General description					Orientation	N-S
					Length (m)	30

Trench revealed two bone lined ditches or land drains. It consisted of ploughsoil and subsoil overlying Pleistocene gravel deposits. The northern end of the trench was excavated to a depth of 2m.					Width (m)	6	
					Avg. depth (m)	0.41	
Context No.	Type	Fill Of	Width (m)	Depth (m)	Description	Finds	Date
22900	Layer			0.21	Ploughsoil. Mid brown clayey silt		
22901	Layer			0.1	Subsoil. Mid - light brown greyish silty clay		
22902	Layer				Natural. Mid to light brown orange silty clay		
22903	Cut		0.93	0.2	Other Cut. Cut is of a possible land drain/boundary made with animal bones		
22904	Fill	22903	0.94	0.2	Primary Fill. Light grey mottled with patches of brownish orange	CBM, Flint	C15th-C19th
22905	Placed Deposit	22903			Other Structure. Linear Bone structure, possibly a land drain/boundary	A. Bone	
22906	Layer			0.18	Alluvial Layer. Plastic yellowish brown mottled grey clayey silt.		
22907	Layer			0.11	Alluvial Layer. Light grey mottled white and yellow slightly clayey silt, possible inclusion of tufa.		
22908	Layer			0.33	Other Layer. Light greyish brown sandy and clayey silt. FLUVIAL DEPOSIT		
22909	Layer			0.3	Other Layer. Brownish grey silty sand, weakly structured		
22910	Layer			0.19	Other Layer. Grey mottled brown clayey sand with frequent mainly rounded flint pebbles (20%).		
22911	Layer			0.06	Natural. Strong brown sand, wavey contact		
22912	Placed Deposit		0.15		Other Structure. Linear structure comprised of animal bone, possibly a land drain or boundary. Running north to south.	Flint, A. Bone	Mesolithic

<b>Trench 230</b>		
General description	Orientation	E - W
Trench revealed two ditches and a bone-lined land drain. Consists of ploughsoil and subsoil overlying a possible buried soil and a natural geology of Pleistocene sand and gravel.	Length (m)	30
	Width (m)	6
	Avg. depth (m)	1

Context No.	Type	Fill Of	Width (m)	Depth (m)	Description	Findings	Date
23000	Layer			0.3	Topsoil. Dark greyish brown clayey silt	Flint	
23001	Layer				Natural. 0.3 to 0.55mBGL yellowish brown clayey silt. Possible Brick Earth Type deposit.		
23002	Layer			0.25	Natural. 0.55 to 0.8m, soft pale brown mottled brown and yellow sandy clay. WEATHERED BEDROCK	Flint	Mesolithic?
23003	Layer			0.78	Natural. 0.8 to 1.58m silty sand, light brown with common pale green and yellowish red mottles. Rate straight clayey silt lenses. PLEISTOCENE		
23004	Layer			0.07	Natural. 1.58 to 1.65m not bottomed, brownish grey sandy gravel. THANET SAND FORMATION		
23005	Cut		0.4		Ditch. Ditch running NE SW		
23006	Fill	23005			Secondary Fill. Mid yellowish brown soft sandy silt. Secondary silting	Flint	
23007	Fill	23005			Secondary Fill. Dark orangey brown soft sandy silt. Secondary backfill. Flint found		
23008	Cut		0.65		Ditch. NE-SW running ditch.		
23009	Fill	23008			Secondary Fill. Dark blackish brown soft sandy silt. Secondary backfill	Flint A. Bone	
23010	Cut		0.8	0.2	Other Cut. Cut of field drain with fill of bones		
23011	Placed Deposit	23010		0.1	Primary Fill. Primary deposit of animal bones in field drain	A. Bone	
23012	Fill	23010		0.1	Secondary Fill. Fill of field drain		
23013	Layer			0.1	Buried soil. Grey mottled brown slightly sandy silt		
23014	Layer			0.18	Alluvial Layer. Grey mottled white and yellow silt.		

### Trench 231

General description	Orientation	N-S
Trench devoid of archaeology. Consisted of ploughsoil and subsoil overlying Pleistocene deposits. Excavated to a depth of 2m at the northern end.	Length (m)	30
	Width (m)	6
	Avg. depth (m)	0.4

Context No.	Type	Fill Of	Width (m)	Depth (m)	Description	Finds	Date
23100	Layer			0.3	Ploughsoil. Dark grey brown sandy silt		
23101	Layer			0.1	Subsoil. grey brown sandy silt		
23102	Layer			0.4	Natural. grey silty fluvial deposit overlying Pleistocene gravels		

### Trench 232

General description					Orientation	N-S
Trench consists of ploughsoil and subsoil overlying a sandy clay natural. Trench devoid of archaeology.					Length (m)	30
					Width (m)	2
					Avg. depth (m)	0.6

Context No.	Type	Fill Of	Width (m)	Depth (m)	Description	Finds	Date
23200	Layer		1.8	0.25	Ploughsoil. Dark brown/grey clayey silt.		
23201	Layer		1.8	0.35	Subsoil. Medium grey/brown clayey silt.		
23202	Layer		1.8		Natural. Pale yellow/grey silty clay.		

### Trench 233

General description					Orientation	E-W
Trench revealed several small tree throw holes, some of which produced worked flint. Trench consisted of ploughsoil and subsoil overlying the natural geology.					Length (m)	30
					Width (m)	2
					Avg. depth (m)	0.33

Context No.	Type	Fill Of	Width (m)	Depth (m)	Description	Finds	Date
23300	Layer		2	0.24	Ploughsoil. Light grey brown silty clay.		
23301	Layer		2	0.13	Subsoil. Mid orangey brown silty clay.		
23302	Layer		2		Natural. Light yellow brown silty clay.	Flint	
23303	Cut		1.06	0.34	Natural Feature. Probable tree bole. Steep sides with concave U-shaped base.		
23304	Fill	23303	0.97	0.34	Other Fill. Very friable light yellow brown silty clay. Change in natural soil.		
23305	Fill	23303	0.38	0.13	Other Fill. Very friable light grey brown sandy clay. Change in the natural.		
23306	Cut		0.78	0.9	Natural Feature. Cut of tree bole.		

### Trench 234

General description					Orientation	N-S
---------------------	--	--	--	--	-------------	-----

Trench revealed two pits and a large E-W aligned hollow. Consisted of ploughsoil and subsoil overlying the natural geology of sandy gravels. Trench excavated to a depth of 2m at the northern end.					Length (m)	30	
					Width (m)	6	
					Avg. depth (m)	0.5	
Context No.	Type	Fill Of	Width (m)	Depth (m)	Description	Finds	Date
23400	Layer			0.26	Ploughsoil. Dark greyish brown silt, rare stone inclusions		
23401	Layer		0.18		Subsoil. Light yellowish brown silt. Subsoil derived from FINE GRAINED SLOPE DEPOSIT/BE TYPE DEPOSIT		
23402	Layer			0.4	Natural. Light yellowish brown mottled strong brown slightly clayey silt		
23403	Layer			0.2	Natural. Light grey silt, mottled strong brown with light grey lines		
23404	Layer			0.15	Natural. Brown slightly clayey and sandy silt, frequent matrix supported flint pebbles and cobbles (30%). PLEISTOCENE DEPOSIT		
23405	Layer			0.2	Natural. Light grey clayey fine sand with abundant flint pebbles and cobbles (70%). PLEISTOCENE DEPOSIT		
23406	Layer			0.13	Natural. Light brownish grey silty sand with abundant flint pebbles and cobbles (50%). PLEISTOCENE DEPOSIT		
23407	Layer			0.17	Natural. Light yellowish the sand with frequent (30-45%) flint pebbles, cobbles and nodules <300mm (45%). PLEISTOCENE DEPOSIT		
23408	Cut		6.95	0.35	Natural Feature. Cut of Natural linear, over 1.8m length. Gentle straight uneven sides, Concave base.		
23409	Layer		6.95	0.17	Alluvial Layer. Mid to light reddish yellow silty clay with light grey silty clay inclusions. Compact. Fills cut 23408, not a fill itself. Possibly Natural 23407 with higher quantities of leached grey clay.		
23410	Layer		7	0.15	Alluvial Layer. Light grey sandy clay with	Flint Pot	MBA-MIA

					occasional red clay inclusions. Moderate. No stones.		
23411	Layer		5.5	0.28	Alluvial Layer. Mid to dark grey sandy clay. frequent stone/gravel and red clay inclusions. Friable.	FC, Flint	
23412	Cut		1.2	0.4	Natural Feature. Irregular shaped tree bowl. Shallow on some edges, steep on others, irregular base.		
23413	Fill	23412	1.2	0.4	Primary Fill. Friable light grey blue with some orange mottling, silty clay.	Flint	
23414	Cut		1.02	0.47	Pit. Sheer sided, sub-circular pit.		
23415	Fill	23414			Primary Fill. Mixed fill of natural (23402) and mid grey silty clay (23416).	Pot	MBA-MIA
23416	Fill	23414	1.02	0.41	Secondary Fill. Mid grey silty clay.	Flint	
23417	Unexc feature		0.16		Ditch. Land drain using animal bones in its construction.		
23418	Fill	23414	0.35	0.05	Tertiary Fill. Orangey brown silty clay.		
23419	Cut		0.67	0.41	Pit		
23420	Fill	23419		0.41	Secondary Fill. mid grey sandy silt		
23421	Cut		0.51	0.06	Pit		
23422	Fill	23421		0.06	Secondary Fill. mid grey sandy silt		

### Trench 235

General description					Orientation	N-S	
Trench revealed a large E-W aligned hollow at the northern end and a ditch at the southern end. Consisted of ploughsoil and subsoil overlying the natural geology.					Length (m)	30	
					Width (m)	2	
					Avg. depth (m)	0.4	
Context No.	Type	Fill Of	Width (m)	Depth (m)	Description	Finds	Date
23500	Layer				Ploughsoil. Dark greyish brown silty clay, friable.		
23501	Layer				Subsoil. Mid to dark brown silty clay.		
23502	Layer				Natural. Pale to mid yellowish grey silty clay.		
23503	Cut		1.65	0.55	Ditch. Oriented E-W.		
23504	Fill	23503	1.35	0.4	Primary Fill. Mid grey clayey silt, iron rich.	FC Flint Pot	Beaker-MIA
23505	Fill	23503	1.65	0.17	Secondary Fill. Pale grey clayey silt.		
23506	Cut		7.2		Natural Feature. Not bottomed.		



23507	Fill	23506			Secondary Fill. Mid greyish brown, silty clay. It contains so many flecks of mineral iron.	FC Flint Pot A. Bone,	LBA-MIA
23508	Fill	23506			Secondary Fill. Mid greyish brown, silty clay. Friable texture.		
<b>Trench 236</b>							
General description					Orientation		N-S
Trench devoid of archaeology. Consists of ploughsoil and subsoil overlying the natural geology.					Length (m)		30
					Width (m)		2
					Avg. depth (m)		0.5
Context No.	Type	Fill Of	Width (m)	Depth (m)	Description	Finds	Date
23600	Layer			0.21	Topsoil. Dark greyish brown silt, PLOUGH SOIL		
23601	Layer			0.1	Subsoil. Brown silt		
23602	Layer			0.29	Natural. Light yellowish brown silt		
23603	Layer			0.15	Natural. Brown clayey sandy silt (silt loam) with abundant flint pebbles and rare cobbles. PLEISTOCENE HEAD DEPOSIT		
<b>Trench 237</b>							
General description					Orientation		E-W
Trench revealed a large E-W aligned ditch and a smaller N-S aligned feature. Consisted of ploughsoil and subsoil overlying the natural geology.					Length (m)		30
					Width (m)		2
					Avg. depth (m)		0.4
Context No.	Type	Fill Of	Width (m)	Depth (m)	Description	Finds	Date
23700	Layer			0.27	Topsoil. Dark brown, sandy silt		
23701	Layer			0.22	Colluvial Layer. Mid brown gravelly silt		
23702	Layer				Natural. Dark greyish brown, sandy gravel		
23703	Cut		1.34	0.51	Ditch		
23704	Fill	23703	1.34	0.51	Primary Fill. Mid Brown, sandy silt	FC Flint Pot A. Bone	MIA
23705	Cut		0.35	0.26	Natural Feature		
23706	Fill	23705	0.35	0.26	Primary Fill. Mid greyish brown, sandy silt		
<b>Trench 238</b>							
General description					Orientation		N-S
					Length (m)		30

Trench revealed a large E-W aligned ditch and two further ditches containing Roman pottery. Trench consisted of ploughsoil and subsoil overlying the natural geology of sandy gravel. Excavated to a depth of 2m at the northern end.					Width (m)	6	
					Avg. depth (m)	0.4	
Context No.	Type	Fill Of	Width (m)	Depth (m)	Description	Finds	Date
23800	Layer			0.2	Topsoil. Dark brownish grey silt, almost stone free.		
23801	Layer			0.6	Natural. Strong brown, becoming brownish yellow slightly clayey silt, stone free. SLOPE DEPOSIT/BRICK EARTH TYPE DEPOSIT		
23802	Layer			0.3	Natural. 0.6 to 0.9m BGL Greyish brown sandy silty clay with abundant 60% subang. to rounded flint pebbles. HEAD DEPOSIT		
23803	Layer			0.2	Natural. Light brownish grey gravelly silty sand, inclusions of rounded to sub-angular and nodular flint <100mm. HEAD DEPOSIT/ FLUVIAL SANDY GRAVEL		
23804	Layer			0.4	Natural. Irregularly stratified light brown mottled yellow sand with lenses of grey silty clay and brown gravelly sand, cryoturbated? PLEISTOCENE FLUVIAL SAND		
23805	Layer			0.5	Natural. Weakly stratified olive grey and reddish brown (fe-staining) mainly coarse sand with common sub-angular to rounded flint pebbles and cobbles <100mm. PLEISTOCENE FLUVIAL GRAVELLY SAND		
23806	Cut		0.88	0.27	Ditch		
23807	Fill	23806	0.88	0.27	Deliberate Backfill.	FC Cu Pot	AD25-60
23808	Unexc feature				Ditch.	Pot	AD43-120
23809	Cut		0.66	0.26	Ditch		
23810	Fill	23809	0.66	0.26	Deliberate Backfill. Mid greyish brown, silty clay.		
23811	Unexc feature				Ditch. Same as 23703		

<b>Trench 239</b>							
General description					Orientation		NW-SE
Trench revealed one ditch and one pit. Consists of ploughsoil and subsoil overlying natural sandy clay.					Length (m)		30
					Width (m)		2
					Avg. depth (m)		0.4
Context No.	Type	Fill Of	Width (m)	Depth (m)	Description	Finds	Date
23900	Layer			0.3	Ploughsoil. Dark greyish brown, silty clay. Friable texture.		
23901	Layer			0.1	Subsoil. Mid brown, silty clay. Friable texture.		
23902	Layer				Natural. Light orangey brown, sandy clay.		
23903	Cut		1.4	0.5	Pit.		
23904	Fill	23903	1.4	0.5	Secondary Fill. Orangey brown sandy silt	FC Flint Pot	IA?
23905	Unexc feature				Ditch.		
<b>Trench 240</b>							
General description					Orientation		N-S
Trench revealed a couple of ditches with, roughly, NE-SW orientation. Consists of ploughsoil and subsoil overlying natural geology of sandy clay.					Length (m)		30
					Width (m)		2
					Avg. depth (m)		0.42
Context No.	Type	Fill Of	Width (m)	Depth (m)	Description	Finds	Date
24000	Layer			0.31	Ploughsoil. Dark greyish brown, silty clay. Friable texture.		
24001	Layer			0.11	Subsoil. Mid brown, silty clay. Friable texture.	Pot	Roman
24002	Layer				Natural. Light orangey brown, sandy clay with so many and large patches of pebbles.		
24003	Cut		1.08	0.16	Ditch. Ditch or pit		
24004	Fill	24003	1.08	0.16	Secondary Fill. Light yellowish brown soft sandy silt		
24005	Cut		1.43	0.32	Ditch. Linear ditch		
24006	Fill	24005	1.43	0.32	Secondary Fill. Mid yellowish brown soft sandy silt	Flint Pot	E.Roman
24007	Cut		1.4	0.38	Ditch. Linear ditch		
24008	Fill	24007	1.4	0.38	Secondary Fill. Dark yellowish brown soft sandy silt	Pot	IA
24009	Cut				Natural Feature. Possible tree throw. No finds		
<b>Trench 241</b>							

General description						Orientation	N-S
Trench consists of ploughsoil and brickearth derived subsoil overlying a sandy gravel natural Head Deposit. Trench revealed one NW-SE gully.						Length (m)	30
						Width (m)	2
						Avg. depth (m)	0.55
Context No.	Type	Fill Of	Width (m)	Depth (m)	Description	Finds	Date
24100	Layer		1.8	0.25	Ploughsoil. Dark greyish brown sandy silt.		
24101	Layer		1.8	0.2	Other Layer. Light yellowish brown sandy silt. Brickearth deposit		
24102	Layer		1.8		Natural. Mixed light yellowish brown and mid reddish brown sandy gravel. Head Deposit		
24103	Cut		0.6	0.11	Ditch		
24104	Fill	24103	0.6	0.11	Primary Fill. Dark grey/brown sandy silt.	Pot Flint	c 1050-1150?
<b>Trench 242</b>							
General description						Orientation	E-W
Trench revealed a single trench N-S aligned at the eastern end and two ditches at the western end, both aligned NW-SE. Consists of ploughsoil and subsoil overlying natural geology of sandy clay.						Length (m)	30
						Width (m)	2
						Avg. depth (m)	0.6
Context No.	Type	Fill Of	Width (m)	Depth (m)	Description	Finds	Date
24200	Layer			0.35	Ploughsoil. Dark greyish brown, silty clay. Friable texture.		
24201	Layer			0.2	Subsoil. Mid brown, silty clay. Friable texture.		
24202	Layer				Natural. Light orangey brown, sandy silt with some gravelly patches (pebbles).		
24203	Cut		0.59	0.07	Ditch		
24204	Fill	24203	0.59	0.07	Primary Fill. Loose mid brown greyish sandy silt with occasional rounded flint stone inclusions, approximately 25mm in size.		
24205	Cut		1.53	0.25	Ditch		
24206	Fill	24205			Primary Fill. Mid brown moderately compacted silty sand with inclusions of frequent rounded flint stones approximately 25mm - 80mm	A. Bone Pot	Early Roman
24207	Cut		1.05	0.2	Ditch		
24208	Fill	24207			Primary Fill. Mid brown silty sand with moderate compaction.		
24209	Unexc feature		0.8		Ditch. Grey brown silty clay		

24210	Unexc feature				Ditch. Grey brown silty clay		
<b>Trench 243</b>							
General description					Orientation		NE-SW
Trench revealed two parallel ditches at the north-east end. Consisted of ploughsoil and subsoil overlying the natural geology.					Length (m)		30
					Width (m)		2
					Avg. depth (m)		0.5
Context No.	Type	Fill Of	Width (m)	Depth (m)	Description	Finds	Date
24300	Layer			0.23	Ploughsoil. Dark greyish brown, friable silty clay		
24301	Layer			0.18	Subsoil. Mid reddish brown, friable silty clay		
24302	Layer				Natural. Light reddish brown, moderate silty clay. Patches of pebbles in mid greyish brown, loose sandy silt		
24303	Cut		1.2	0.38	Ditch		
24304	Fill	24303	1.2	0.38	Primary Fill. Mid greyish brown, moderate silty clay		
24305	Cut		0.34	0.09	Ditch		
24306	Fill	24305	0.34	0.09	Primary Fill. Light greyish brown, moderate silty clay		
<b>Trench 244</b>							
General description					Orientation		NW-SE
Trench devoid of archaeology. Consists of ploughsoil and subsoil overlying geology of sandy clay.					Length (m)		30
					Width (m)		2
					Avg. depth (m)		0.38
Context No.	Type	Fill Of	Width (m)	Depth (m)	Description	Finds	Date
24400	Layer			0.3	Ploughsoil. Dark greyish brown, silty clay. Friable texture.		
24401	Layer			0.08	Subsoil. Mid reddish brown, silty clay. Friable texture.		
24402	Layer				Natural. Orangey brown sandy clay		

### B.1 Prehistoric Pottery

By Alex Davies

#### Introduction

B.1.1 The evaluation produced 393 sherds of prehistoric pottery weighing 2606g from 64 contexts across 39 trenches (Table 1). The overall mean sherd weight was 6.8g. Many contexts could only be spot-dated to the middle Bronze Age-middle Iron Age, based on flint fabrics on body sherds with little or no recognisable form. Six contexts produced possibly early Neolithic flint-tempered body sherds, but none were diagnostic. A single probable Beaker sherd was found, likely to be residual as probable later prehistoric pottery was found in the same context (23504). Diagnostic late Bronze Age, early Iron Age and middle Iron Age material was also found. This report does not consider late Iron Age material, which is dealt with alongside the Roman pottery, below.

#### Methodology

B.1.2 Pottery from each context was scanned with spot-dates given based on the latest material present. Any clearly earlier (residual) pottery was noted. Fabrics were recorded in order of their approximate frequency in any one context. The two most common inclusion types were noted, using the following fabric codes:

- FI - Flint
- Gr - Grog
- Qg - Glauconitic sand (can include quartz sand)
- Qs - Quartz sand
- Sh - Shell (all voids, could include limestone or other calcareous material)

B.1.3 The grade of the fabric was also recorded with a number suffix, ranging from 1 (fine) to 4 (very coarse).

B.1.4 All the data that was recorded is presented in Table 1. There is no additional data or metadata.

#### Fabrics

B.1.5 Most of the contexts comprised formless, undecorated body sherds that can only be dated by fabric. Prehistoric fabrics in the region are particularly undiagnostic as calcined flint is the dominate inclusion during most of prehistory, with the late Neolithic to early Bronze Age (inclusive) the only periods where other inclusions apart from flint dominate, in this case grog. For example, at Mucking, c 1.5km to the north-east of the site, flint was the dominate local fabric during the middle and late Bronze Age, being steadily replaced with quartz sand through the Iron Age. Flint still remained popular well into the middle Iron Age, with sand only becoming dominant around the second century BC. Shell (mostly degraded) was a minor component throughout later prehistory (Barrett 1988; Brown 1998; Brudenell 2016a; 2016b). The ubiquitous use of flint has led to wide spot dates for many of the contexts as featureless body sherds

dominated the assemblage. Twenty-nine contexts were broadly dated to the middle Bronze Age-middle Iron Age based on predominantly flint tempered body sherds, with occasional sandy and shell-tempered sherds. There may be scope to refine the dating of some based on contextual associations, and these are discussed below.

### **Early Neolithic**

- B.1.6 Six contexts produced possibly early Neolithic pottery: 6704, 14108, 15107, 16310, 16316, 17621. This totalled 14 sherds (58g). All of these were featureless body sherds in a flint fabric that differed to the material that was spot-dated to the later prehistoric period, as the flint inclusions are larger and more sporadically distributed within the fabric (poorly sorted). As no particularly diagnostic early Neolithic sherds were present, however, and the fabric is still similar to later prehistoric types, some or all of these six contexts might date to the middle Bronze Age to middle Iron Age. Context 15107, for example, also produced later prehistoric and late Iron Age or Roman material, and the possible early Neolithic sherd is either of later date or is residual. Associated worked flint was found in contexts 16310, 16316 and 17621, but no assemblage was diagnostically Neolithic, so this does not assist dating.
- B.1.7 Context 6704 is the fill of a seemingly isolated, charcoal-rich pit 6703. Context 14108 is also from a seemingly isolated pit, 14107. Context 16316 is the fill of a tree throw hole. These are contexts that would be expected for the early Neolithic, although also possible for the Bronze Age or Iron Age. Context 16310 is a ditch fill, and context 17621 is the fill of a grave. These are less common early Neolithic contexts, perhaps making it less likely that the pottery is of this date, or that the sherds are residual. Nevertheless, the material from both contexts should be considered as possible early Neolithic.

### **Beaker**

- B.1.8 A single 1g sherd of probable Beaker pottery was found in context 23405. This is the only prehistoric grog tempered sherd from the evaluation and is thin-walled and well-fired but undecorated. A 4g flint tempered sherd was found in the same context that is probably not from a Beaker, meaning the Beaker sherd in 23405 is probably residual.

### **Late Bronze Age**

- B.1.9 No certain middle Bronze Age pottery was present. All of the prehistoric pottery in Trench 49 was late Bronze Age, as was context 4810, the only context in Trench 48 to produce prehistoric pottery. No other clearly late Bronze Age pottery came from the site. The pottery from these two trenches totals 56 sherds (676g), having a mean sherd weight of 12.1g, nearly twice that of the assemblage as a whole. The only featured sherd in this group is a fingertipped rim from a shouldered or carinated jar in context 4904, which typologically could instead belong to the early Iron Age, but all of the pottery is hard-fired and thin-walled, which is characteristic of the late Bronze Age. All but one of the sherds contains medium-grade flint inclusions found thought the later prehistoric period in the area; the exception is one sandy sherd. The material in Trench 49 was associated with the briquetage from the site, and this corresponds with the late Bronze Age date.

### **Late Bronze Age – early Iron Age**

- B.1.10 Five contexts were spot-dated to the late Bronze Age-early Iron Age (402, 1704, 10904, 14904, 18422), and two to the late Bronze Age-middle Iron Age (19603,

23507). This pottery is mainly in medium-grade flint tempered fabrics with some sandy material, and included sherds that are morphologically unlikely to date to the middle Bronze Age but whose date cannot be further refined. These are mainly shouldered vessels, except for an upright rim from a bowl in context 402.

## **Iron Age**

- B.1.11 A single sherd has been tentatively spot-dated to the early Iron Age. This was the only sherd in context 9811, and is phased to the period as it is probably red-coated, possibly with haematite.
- B.1.12 Eight contexts were spot-dated to the middle Iron Age: contexts 15107, 15111, 15112, 17504, 17811, 18303, 18417 and 23704. This totals 117 sherds (936g) with a mean sherd weight of 8g. Flint and sandy fabrics are about equal, and material with glauconitic sand is found in contexts 15111 and 15112. Glauconitic sand is particularly diagnostic of the middle Iron Age in the region (e.g. Mucking fabric S2: Brudenell 2016b, 367). Sherds in this glauconitic sandy fabric was associated with middle Iron Age burnished globular bowls in context 15112, and one of these bowls had external carbonised residue. The other contexts spot-dated to the middle Iron Age include globular, S-profile and/or slack-sided vessels, all middle Iron Age forms. Many of these are burnished.
- B.1.13 The material in context 15107 is mainly datable to the middle Bronze Age to middle Iron Age, but includes a possible early Neolithic sherd and a wheel-thrown sherd in a leached shell fabric dating to the late Iron Age or Roman period. The middle Iron Age activity in this trench appears therefore to continue into later periods. Other late Iron Age or Roman pottery is dealt with in a separate report, below.
- B.1.14 The trenches producing middle Iron Age pottery were together in the south-eastern part of the site, within an area of c 2ha. Other trenches in this area producing prehistoric pottery include 176, 180, 183, 185, 196, 234, 235, 239 and 240. The prehistoric pottery from these trenches all has spot-date ranges that include the middle Iron Age, and it is possible that all of the pottery in these trenches is middle Iron Age.
- B.1.15 Seven contexts were spot-dated only broadly to the Iron Age: contexts 17804, 17808, 17809, 18301, 18308, 23904 and 24008. These are featureless body sherds that included appreciable numbers of sandy sherds, making them more likely to be Iron Age than later Bronze Age. Other contexts in Trenches 178 and 183 date to the middle Iron Age making it likely that at least these are also middle Iron Age in date.

## **Prehistoric**

- B.1.16 Pottery in two contexts could only be dated to the prehistoric period: contexts 8402 and 17510. The sherds in context 8402 have an unusual combination of flint and grog in the fabric, and that from 17510 is very small and abraded.

## **Retention**

- B.1.17 All the pottery has further research potential and should be retained.



Context	Count	Weight (g)	Fabric	Spot-date	Comment
402	10	52	FI2, Qs2, FIQs2	LBA-EIA	Small upright rim from a bowl
410	4	4	FI2	MBA-MIA	Small and abraded
503	6	22	FI2	MBA-MIA	
507	2	7	FI2	MBA-MIA	
1704	28	100	FI1, Qs2	LBA-EIA	Sample 11. Prob x2 shouldered bowls, and ovoid vessel. More likely LBA?
3104	1	7	FI2	MBA-MIA	
4601	3	5	FI2	MBA-MIA	Small and abraded
4701	2	1	FI2	MBA-MIA	Small and abraded
4810	1	23	Qs2	LBA?	Formless body sherd but thin-walled and hard fired like Tr49
4904	23	301	FI2	LBA	x3 sherds sample 73. Fingertipped rim from shouldered or carinated jar. In same thin walled hard fired as rest of Tr 49.
4905	19	276	FI2	LBA	Formless body sherds, but thin-walled and hard fired suggests LBA
4907	13	76	FI2	LBA?	Formless body sherds but thin-walled and hard fired suggests LBA
6704	1	3	FI3 (poorly sorted)	E Neo or MBA-MIA	Sample 87. Small sherd, possible shoulder. Poorly sorted fabric so poss E Neo, but broad spot date including MBA-MIA
6905	3	5	FI2, Sh2(voids)	MBA-MIA	
7901	2	15	FI2	MBA-MIA	
8402	3	6	FIGr2	Prehistoric	Combination of flint and grog gives a very wide spot-date
8901	3	20	FI2	MBA-MIA	
8902	2	1	FI2	MBA-MIA	Very small and abraded
9711	1	7	FI2	MBA-MIA	Well-fired. LBA?
9811	1	5	FI2	EIA?	Probably red-coated, but not certain
9901	1	5	FI2	MBA-MIA	Small find 135. 5
10908	2	10	FI2	LBA-EIA	Slight shoulder, so prob LBA-EIA
11303	3	14	FI2, Qs2	MBA-MIA	A sandy sherd, so more likely IA, but just 1 sherd
12502	2	2	FI2	MBA-MIA	Small and abraded
13814	2	6	FI1	MBA-MIA	
14104	1	4	FI2	MBA-MIA	Appears basically the same as MBA-MIA, but given the possibility of 14104 it could be E Neo - only a small sherd

Context	Count	Weight (g)	Fabric	Spot-date	Comment
14108	2	15	FI3 (poorly sorted), FI2	E Neo or MBA-MIA	Poorly sorted coarse fabric in one sherd which looks different to the rest of MBA-MIA, which could be E Neo. But only two small sherds so uncertain and could be MBA-MIA
14904	4	29	FI2	LBA-EIA	Probable shouldered jar, hard fired, probably LBA. But broken at shoulder so not completely sure
15107	9	77	FI2, Sh2(voids), FI3(poorly sorted), Qs2	MIA?	x2 sherds from sample 194. A mixed bag - 1 sherd of poorly sorted flint that could be E Neo; most of the context spot-datable to MBA-MIA, but 1 sherd of wheel-thrown shell(voids) fabric - LIA/R. The rest of the context is earlier
15111	8	28	FI2, Qg1	MIA	
15112	51	529	Qs1, Qg1, FI2, Sh2(voids)	MIA	Burnished globular bowls, one with external carbonised residue
16104	4	15	FI2	MBA-MIA	
16310	4	6	FI3 (poorly sorted)	E Neo or MBA-MIA	Poorly sorted coarse fabric that could be E Neo, but small abraded sherds so could be MBA-MIA
16316	1	1	FI3 (poorly sorted)	E Neo or MBA-MIA	Poorly sorted coarse fabric that could be E Neo, but small abraded sherd so could be MBA-MIA
17504	4	58	Qs2, FI2	MIA	Burnished S-profile jar, with line of decoration
17510	1	1	FI2	Prehistoric	Very small and abraded
17621	5	27	FI3 (poorly sorted)	E Neo or MBA-MIA	Inc sample 184. Poorly sorted coarse fabric which looks different to the rest of MBA-MIA, and could be E Neo.
17804	5	8	Qs2, FI2	IA	Probably IA as mainly sand, but could be earlier
17808	12	71	FI2, Qs2	IA	Inc 3 sherds in sample 131. Probably IA as sand, but could be earlier
17809	10	45	Qs2, FI2	IA	Probably IA as mainly sand, but could be earlier
17811	12	73	Qs2, FI2	MIA	Burnished everted rim, prob MIA but could be EIA
17817	1	1	FI2	MBA-MIA	
17821	3	4	FIQs2	MBA-MIA	
18010	1	4	FI2	MBA-MIA	

Context	Count	Weight (g)	Fabric	Spot-date	Comment
18301	2	36	Qs2	IA	Sandy so prob IA, but just body and base sherd. Could be earlier
18303	20	80	Qs2	MIA	Burnished round-bodied and sandy
18308	2	4	Qs2	IA	
18417	7	36	FI2, Qs2	MIA?	Burnished sherd prob from a slack sided vessel, but could be angular EIA
18420	6	32	FI2	MBA-MIA	
18422	8	46	FI2, Qs1, Qs2	LBA-EIA	A prob angular bowl, and a prob fingertip
18508	1	4	FI2	MBA-MIA	
18606	7	8	FI2, Qs2	MBA-MIA	
19603	10	53	FI2, Qs2	LBA-MIA	Slight shoulder, so prob not MBA. Slight enough that it could be MIA
19604	2	12	FI2	MBA-MIA	
19605	5	16	FI2, Qs2, Sh2(voids)	MBA-MIA	
19609	2	2	FIQs2	MBA-MIA	Small and abraded
23410	4	8	FI2	MBA-MIA	
23415	1	62	FI2	MBA-MIA	
23504	2	5	FI2, Gr1	Beaker-MIA	1 small quite fine, thin walled and well fired grog tempered sherd that could be Beaker. The other sherd is very abraded flint tempered that could be virtually any prehistoric date. Possible that context is Beaker, but the grog sherd is likely residual in a probably later context?
23507	14	69	FI2	LBA-MIA	Slight shoulder, so prob not MBA. Slight enough that it could be MIA
23704	6	55	Qs2	MIA	Globular bowl with slight everted neck
23904	3	7	FIQs2, FI2	IA?	Sample 39. Sand so more likely IA, and a possible IA slight beaded rim, but uncertain. Could be earlier
24008	14	98	FI2, FI3, Sh2(voids), Qs2, Qs1	IA	Range of fabrics. Burnished fine sandy sherd so prob IA
Unstratified	1	4	FI2	MBA-MIA	Base sherd with slightly protruding 'foot'. But small sherd and not diagnostic to period
	<b>375</b>	<b>2536g</b>			

Table 1: Quantification and spot dates of Prehistoric pottery

## B.2 Late Iron Age and Roman Pottery

By Kate Brady

### Introduction

B.2.1 Some 246 sherds of late Iron Age and Roman pottery, weighing 2546g, were recovered from the evaluation (Table 2). Context-groups were sorted into fabrics and each fabric group quantified by sherd count and weight in grammes. Fabrics were assigned codes devised by the Essex County Council Field Archaeology Unit (cf. Biddulph *et al.* 2015). Forms were identified by rim and quantified by minimum number of vessels (MV) and estimated vessel equivalents (EVE), which measure the surviving percentage of the rim circumference (thus, 0.25 EVE equals 25%). Forms codes were taken from Going's Chelmsford typology (Going 1987). Forms and fabrics are quantified in Tables 2 and 3.

Fabric	Description	Count	Weight (g)	MV	EVE
BSW	Black-surfaced wares	21	200	4	0.29
EGSW	East Gaulish samian ware (LGF SA)	1	3	1	0.03
ESH	Early shell-tempered ware	35	279	1	0.05
GRF	Fine grey wares	13	83	1	0.11
GROGF	Fine grog-tempered ware (SOB GT)	31	297	2	0.13
STOR	Storage jar fabrics	13	579		
GRS	Sandy grey wares	30	413	1	0.15
MICW	Miscellaneous Iron Age coarse wares	58	344	5	0.19
NGWF	North Gaulish fine whiteware	24	194	1	0.48
RED	Miscellaneous red wares	13	139		
UPOT	Unidentified pottery	5	4		
UWW	Un sourced white-ware	1	5	1	0.1
VRW	Verulamium region white-ware (VER WH)	1	6		
<b>Total</b>		<b>246</b>	<b>2546</b>	<b>17</b>	<b>1.53</b>

Table 2: Quantification of late Iron Age and Roman fabrics (codes in brackets from Tomber and Dore 1998)

Form	Description	BSW	EGSW	GROGF	MICW	NGWF	GRS/GRF	UWW	Total EVE
B	Bowl/dish		0.03						0.03
G	Jar	0.11			0.1				0.21
G3	Bead-rim jar				0.03				0.03
G5	Lid-seated jar	0.03							0.03
G17	Necked jar	0.07		0.13					0.2
H	Beaker						0.15		0.15
H7	Butt-beaker					0.48			0.48
J	Flagon						0.11	0.1	0.21
	Jar/bowl	0.05			0.06				0.11
<b>Total EVE</b>		<b>0.26</b>	<b>0.03</b>	<b>0.13</b>	<b>0.19</b>	<b>0.48</b>	<b>0.26</b>	<b>0.1</b>	

Table 3: Quantification by EVE of Roman pottery forms

## **Assemblage composition**

- B.2.2 Four context-groups, representing 24.2% of the assemblage by sherd count (11% by weight), were spot-dated to the late Iron Age period. These were recovered from Trenches 17, 151, and 196. Contexts 15116 (ditch 15115) and 15120 (ditch 15119) contained shell-tempered pottery (ESH) dating from the early 1st to mid-2nd century AD along with a small number of sherds in miscellaneous late Iron Age fabrics. Context 15116 also contained a small amount of grog-tempered pottery of 1st century AD date. Context 19607 (ditch 19606) contained sherds solely in miscellaneous late Iron Age fabrics (most of which were flint- and sand-tempered). Only two rims were recovered, one from a barrel-shaped jar (CB) and one from a jar/bowl of indeterminate form. Both were recovered from ditches in Trench 151.
- B.2.3 Some 65% of the assemblage by sherd count belonged to context-groups spot-dated to the early Roman period (c AD 43-100). The pottery was recovered from ten contexts recorded in Trenches 141, 180, 185, 191, 235, 238, 240 and 242. The largest amount was recovered from Trenches 238 and 240.
- B.2.4 A relatively large group was recovered from context 23807 and 23808 (two interventions into the same ditch (23806)). Pottery diagnostic of the period from this group included a flagon in unsourced whiteware (UWW) (type J3) and another in fine greyware (GRF) (type J1) along with a North Gaulish butt beaker in fine whiteware (NGWF) (type H7/CAM 113). A body sherd from what is almost certainly a jar in fine greyware (GRF) (type G16) also indicates an early Roman date. Body sherds in sandy greywares were found alongside sherds in Roman black-surfaced ware (BSW) and late Iron Age to Roman grog tempered wares (GROGC/ GROGF) and early shell tempered ware (ESH). Overall, a date for deposition within the period AD 43-70 is likely for this group.
- B.2.5 Activity at this time is supported by the presence of a lid-seated jar from context 18519 (Trench 185) paralleled at Mucking (Type A) and dating to the last half of the 1st century AD, and by grog-tempered jars (GROGF) (Thompson type B1/B1-4) from context 24206 (Trench 242). A butt-beaker in sandy greyware (GRS) came from context 24006 in Trench 240. A single body sherd in Verulamium region white-ware was also recorded from 24206, and although this fabric is found up until AD 160, here it was with other sherds dating to AD 43-70.
- B.2.6 A small proportion of the assemblage, 7.6% by sherd count, was from context-groups that could not be dated closely within the Roman period (c AD 43-410). This material was collected from Trenches 3, 5, 32, 48, 68, 92, 93, 94, 149, 178 and 191. The pottery typically comprised undiagnostic sherds in coarse wares (BSW, GRS and RED). All were body sherds and none could be identified to form.

## **Discussion**

- B.2.7 The assemblage spans the late Iron Age and early Roman periods, with the emphasis on the early Roman period. It is possible that some of the pottery was deposited in the late Iron Age. However, it is notable that no relatively large groups containing pottery of late Iron Age tradition exclusively were recovered and that most grog-tempered and early shell-tempered ware was associated with Roman-period fabrics, suggesting that deposition was of early Roman date. No groups were dated with certainty to after the early Roman period.

- B.2.8 Much of the pottery is likely to have been manufactured fairly locally, with the zone of production in the south Essex/ Thameside region on at sites such as Mucking, and the lid seated jar (type G5/ Mucking type A, Lucy and Evans 2016) that was recovered is a staple of this industry. Products of the Verulamium industry were present, but only as a single whiteware body sherd.
- B.2.9 Two vessels were imported; a fine whiteware butt-beaker from North Gaul, and a bowl/dish in samian ware from east Gaul. Both were imported during the early Roman period.
- B.2.10 The condition of the assemblage is mixed. It has a mean sherd weight (weight divided by sherd count) of 9.9g and a mean EVE or 'completeness' value (EVE divided by MV) of 0.08 EVE, which is indicative of a fairly fragmentary assemblage, although some medium-sized sherds were also present. A large portion (0.48 EVE) of a fineware beaker, for instance, was found in context 23807 and the sherds of this vessel were in good condition. However, some context-groups consisted of little more than crumbs weighing less than 1g.
- B.2.11 While the assemblage was distributed across the evaluation area, pottery deposition was concentrated in the south-eastern area of the evaluation and this included a significant proportion of material of early Roman date. Trenches 191, 235, 238, 239, 240 and 242 contained relatively large amounts of pottery by sherd count, while the 'best-preserved' pottery – that is, pottery with high MSWs and above-average mean EVE values – was recorded in Trenches 238 and 242. This suggests that deposition was concentrated in this south-eastern area and that the pottery in this area had been deposited comparatively rapidly after initial breakage. Trenches in this area targeted a concentrated area of features, which may have provided a focus of settlement. Elsewhere, the distribution of pottery was sparser and the pottery in poorer condition, suggesting that these areas were more peripheral to areas of use and that the pottery had undergone multiple episodes of redeposition.

### **Recommendations for retention**

- B.2.12 This assemblage has the potential to inform future research through re-analysis and thus it is recommended that all the pottery is retained. This follows the advice set out in the 'Standard for Pottery Studies in Archaeology' (PCRG *et al.* 2016).

## B.3 Medieval Pottery

By John Cotter

### Introduction and methodology

- B.3.1 A total of 123 sherds of medieval and post-medieval pottery weighing 1447g was recovered from 31 contexts. Ordinary domestic wares were recovered. A range of pottery from perhaps the early/mid Anglo-Saxon period through to the 19th century was identified. Most of it, however, is medieval.
- B.3.2 All the pottery was scanned during the present assessment and spot-dates were provided for each context. Each context group was quantified by sherd count and weight and recorded on a spot-dating spreadsheet. The pottery is mostly in a very fragmentary and abraded condition, but some fresh sherds are also present.
- B.3.3 The context spot-date is the date-bracket during which the latest pottery types or fabrics are estimated to have been produced or were in general circulation. Comments on the range of fabrics were recorded, usually with mention of vessel form (jugs, bowls etc.) and any other attributes worthy of note (eg. decoration etc.). Fabric codes referred to are those of the Museum of London (MoLA 2014a). Where appropriate, these are cross-referenced to the fabric codes used by Essex County Council (Cotter 2000, 12-13). The range of pottery is described in some detail in the spreadsheet (Table 4) and is therefore only dealt with in summary in the further text below.

### Description

Context	Spot-date	Count	Weight (g)	Comments
326	c 1480-1600	7	212	Essex early post-medieval redware (Fabric 40EA). Fresh sherds incl wide bowl with flanged rim; a thumbled base from drinking jug/cup with glz int on floor; a large rounded jug/jar base in reduced fabric with Dutch-style pulled foot (fabric as London PMRE)
327	c 1480-1600	2	10	Bos PMRE
804	c 400-750	2	40	Anglo-Saxon organic-tempered ware (CHAF). Probably 1 vessel? Body sherds
1107	c 1050-1200?	7	82	Early medieval coarseware cpot (cooking pot)-type sherds. 1x Early med shelly (EMSH, c 1050-1150). 3 joining bos from grey coarse sandy ware with much angular flint (mostly under 1mm) with faint grooving/banding on shoulder - possibly early medieval flint-tempered ware (EMFL, c 970-1100) or an Essex sandy F13/20 hybrid with much flint (c 1150-1200?). 1x fresh sagging base from cpot in shelly-sandy ware with moderate flint (London early medieval sand- and shell-tempered ware EMSS. c 1000-1150? Or an early SSWX shelly-sandy ware = London Fabric SSWX/Essex Fabric 12C, from c 1100+)? Fabrics need further research

Context	Spot-date	Count	Weight (g)	Comments
4804	c 900-1050	8	82	Late Saxon-Norman - but Ctx includes 2x joining frags (15g) CBM/tile - thin - incl 1 fresh face & a v rough sanded underside (or lens of sandy clay) in orange sandy fabric - poss a medieval flat roof tile(? c 1170+) but might be a flake from a larger Roman tile?? (extracted, not included in totals here. Intrusive?). 1x bo in fine grey ?Roman sandyware (6g) or less likely Thetford-type ware (THET, c 900-1100). 8 sherds (1 vess) from fresh jar in late Saxon shelly ware with typical everted plain rim (London Fabric LSS, c 900-1050)
8201	c 1580-1800	1	4	Bo black-glazed redware (PMBL)
9003	c 1270-1350?	8	62	Bos from 1 jug. Weathered. No definite glaze surviving. Fine oxidised orange-brown, fairly soft, powdery fabric with much fine mica & poss fine glauconite? Joining bos from lower wall with traces of white slip linear decoration - chevrons - and a bo from the corrugated/rilled neck. Probably Mill Green ware (MG, c 1270-1350, or related). Less likely fine London-type ware (LOND)?
9005	c 1820-1900	1	53	Yellow ware bowl rim with banded slip dec incl mocha dec (YELL SLIP)
9204	c 1270-1350	2	16	Weathered. 1x Mill Green jug bo (MG) with traces of white slip line dec under decayed clear glz (similar to sherd in 9003 but with some coarse rounded quartz). 1x base Mill Green coarse ware (MG COAR)
9209	c 1250-1350?	2	26	1x bo Essex-type shelly-sandy ware (SSWX, c 1100-1350). 1x fresh sagging base from cook pot in MG COAR fabric variant with sparse dissolved shell inclusions and sparse flint (variant seen on other LTC sites in Essex (eg Orsett LTC3020)
9222	c 1050-1150?	1	4	Worn bo shelly ware with fine matrix (early medieval shelly ware EMSH?)
9226	c 1100-1300?	7	38	Bos. Shelly SSWX & 1x worn EMSH
9237	c 1050-1150?	1	2	Worn bo shelly ware with fine matrix (early medieval shelly ware EMSH?). Thin-walled
9238	c 1100-1350	1	4	1x bo cspot Essex-type shelly-sandy ware (SSWX, c 1100-1350). Poss wheel-turned (WT)?
9310	c 1100-1350?	1	8	1x basal bo cspot shelly-sandy ware, slightly gritty (SSWX?)
9317	c 1250-1350?	5	75	1x large fresh conical bowl with developed horizontal rim (form like Essex greyware F20 bowls) in grey shelly-sandy SSWX (poss WT?). 4x small bos/scraps incl shellyware & 2x MG COAR-related cspot fabric with sparse shell and sparse-moderate flint
9402	c 1200-1300?	1	12	Cspot simple everted rim fine shelly fabric as in 9418. Poss joins? Worn



Context	Spot-date	Count	Weight (g)	Comments
9407	c 1200-1300?	10	95	2x fresh joining jug neck/shoulder coarse sandy oxidised (early?) London SOWX/Essex F21 jug with horiz band white slip dec on shoulder under a patchy greenish glz (less likely London LCOAR). 3x hard grey sandyware RCWX/Essex F20 incl 2 squared cspot rims (2 vess, 1 developed c 1250+?). Bos fine shelly ware with sparse shell (MG-related?)
9418	c 1200-1300?	4	84	All shelly ware types. Incl large fresh ?WT cspot with short squared rim in the v fine/silty (MG-related?) light orange-brown fabric with sparse-moderate voided shell and fine mica (otherwise almost inclusion-free) rim & form poss from c 1200/25. 1x thickened everted cspot rim in same fabric as latter (similar to EMSH, see rim in 9402). 2x coarse sandy-shelly SSWX
9421	c 1200-1300?	3	12	2x fine shelly-silty JOINS 9418. 1x small bo in coarser fabric - almost MG COAR (or F21 with rounded quartz & sparse flint, poss rare shell?)
9422	c 1200-1300?	1	72	Large fresh ?WT cspot with short squared rim in the v fine/silty (MG-related?) fabric. JOINS rim in 9418
9802	c 1200-1300?	2	12	1 vess. Sagging cspot base in coarser fabric - almost MG COAR (or F21 with rounded quartz & sparse-moderate coarse flint, poss rare shell?). Probably JOINS 9421
9807	c 1200-1300?	1	2	Bo fine shelly as in 9418
10104	c 1050-1200?	17	298	A group of early medieval-looking fabrics all with varying levels of shell inclusions. Definitely medieval as includes sagging bases from cspots & a large fresh rim sherd from a large cspot with a sub-squared/collared or squared beaded rim on steeply everted neck in a soft dark brown fabric with grey core, sparse-moderate shell and moderate coarse inclusions of grey-brown grog (like Roman grog), sparse coarse quartz & rare flint - form looks very medieval (poss turntable finished) with soapy surfaces - fabric probably Essex early medieval grog-tempered ware (EMGRX, c 1050-1200). Other cspot sagging bases in a fine silty-sandy fabric, some oxidised orange-brown - poss a developed type of London EMSH (c 1050-1150)? some of these are similar to medieval fabrics found around the Hoo Peninsula/Medway estuary in N Kent (eg Kent Fabric EM22 c 1125-1200/50?). These fabrics need more research. No developed 13C-style shelly-sandy wares in this ctx

Context	Spot-date	Count	Weight (g)	Comments
10106	c 1200-1300?	6	68	Shelly wares. Incl sub-squared rim from large cspot in light orange fine silty fabric with moderate shell (MG-related? But probably earlier - from c 1175/1200+?). 2x sandy bos SSWX. 3x worn Essex early medieval grog-tempered ware (London Fabric code EMGRX) incl cspot rim (JOINS 10104, see below) & probably a sagging base from a cspot
10108	c 1830-1900	3	6	1x transfer-printed ware (TPW) dish rim. Developed Creamware (CREA DEV) dish rim. 1x bo grey sandy medieval SSWX
10113	c 1550-1800?	4	16	1x bo post-medieval redware (PMR) with glz int/ext. 3x small bos med shelly wares incl fine MG-related fabric c 1200-1300?
17806	c 1100-1250?	6	20	All low-sand shelly wares (1-2 vess) incl grey sagging base from small cspot. Poss South Essex shell-temp ware (SEMS, c 1100-1300 = Essex F12A/B)? Or EMSH (c 1050-1150)??
18515	c 1050-1200?	4	16	Bos shelly EMSH (1 vess?). Abraded
21304	c 1270-1350	1	6	Fresh bo MG jug with broad white slip-painted dec under clear glaze
24104	c 1050-1150?	4	10	Scrappy bos shelly ware (2 vess, mostly grey/black). EMSH?
<b>TOTAL</b>		<b>123</b>	<b>1447</b>	

Table 4. Description of post-Roman pottery by context

## Discussion

- B.3.4 The pottery comprises ordinary domestic wares typical of this part of south Essex and ranges in date from the early/mid Saxon period through to the 19th century. Medieval wares of the 11th to 14th century, however, predominate.
- B.3.5 Context (804) produced two sherds from a single vessel in early- to mid-Saxon organic-tempered ware (Fabric code CHAF). This ware has a broad date range in south-east England (mainly c 400-750 AD) and shows little or no typological change during the period. Some occupation of this date is therefore attested here.
- B.3.6 A typical cooking pot rim in late Saxon shelly ware (LSS) was recovered from Context (4804) and dates the context to c 900-1050.
- B.3.7 Other 11-12th and early 13th-century fabrics here – particularly the shelly wares and related silty-sandy fabrics (which usually have some shell also) require further research at some future date. This is usually due to their poor and fragmentary condition (often undiagnostic body or base sherds) but also due to their sometimes hybrid characteristics – making positive identification to known fabrics uncertain and therefore allowing only approximate spot-dates to be assigned to the contexts containing them.
- B.3.8 Early medieval shelly ware (EMSH, c 1050-1150) is reasonably common (as on other sites in south Essex). Rarer fabrics probably include early medieval flint-tempered ware (EMFL, c 970-1100) and Essex-type early medieval grog-tempered ware (EMGRX, 1050-1200). The latter can sometimes be confused with Roman period

grog-tempered wares but a large fragment from a distinctive medieval-looking cooking pot rim in this fabric (from 10104) makes its identification here fairly certain. Other silty-sandy greyware fabrics, from the same context as the latter, were noted to have similarities to some medieval fabrics on the north-west Kent side of the Thames estuary. Later shelly wares are represented by Essex-type shelly-sandy ware (SSWX, c 1100-1350), mainly as cooking pots and at least one wide bowl.

- B.3.9 High medieval wares (13-14C) are present in a few contexts in the form of glazed and slip-decorated jug sherds in Mill Green ware (MG, c 1270-1350). Mill Green ware was produced at Ingatestone in central Essex and had a wide distribution in Essex and the Thames estuary area. Mill Green coarse ware (MG COAR), mainly used for cooking vessels, occurs here too, together with a few glazed jug sherds in Essex sandy orange wares (SOWX, c 1200-1550).
- B.3.10 Early post-medieval pottery (c 1480-1600) occurs in a couple of contexts including a small group of vessels in Essex-type early post-medieval redware (Essex Fabric 40EA) from Context (326). A single sherd of local black-glazed redware (PMBL) dates to around 1580-1800. The latest pottery present comprises three sherds of commonplace 19th-century tablewares including transfer-printed ware (TPW).

#### **Recommendations regarding the conservation, discard and retention of material**

- B.3.11 This assemblage has potential to inform research through further analysis. Further work will be needed to positively identify some of the early medieval coarsewares and to research possible connections with north-west Kent. It should all therefore be retained and would benefit from detailed cataloguing and reporting at some future date - along with material from any subsequent formal excavations in this area.

## B.4 Flint

By Lawrence Billington

### Introduction

- B.4.1 A substantial assemblage of 1321 worked flints and almost 35kg of unworked burnt flint was recovered by the trial trenching. The largest and most significant component of the worked flint assemblage derived from a series of *in situ*/minimally disturbed Mesolithic flint scatters located within a restricted number of trenches on the valley floor in Land Parcel 7a, but there was also evidence for widespread prehistoric activity from residual flintwork recovered from cut features and material from topsoil, subsoil and colluvial deposits across the evaluated area.
- B.4.2 This report provides a brief overview and characterisation of the assemblage. Followings some general comments on the provenance, raw material and condition of the assemblage as a whole, the flint from each land parcel is described separately, and the report is concluded by a general discussion. A basic quantification of the assemblage by land parcel is provided in Table 5.

Type/Land Parcel	LP 6	LP 7a	LP 7b	LP 7c	LP 8	Unprovenanced	Totals
Chip		181		19			200
Irregular waste	1	31		29	3	2	66
Flake	38	403	12	168	27	5	653
Blade	4	122	6	41	8	2	183
Bladelet	2	73	1	17	1		94
Blade-like flake	2	25	1	16			44
Core tablet		2		2			4
Crested blade/flake		7		2	1		10
Axe/adze sharpening flake		1					1
Microburin		1					1
End scraper		4		1			5
Side scraper				1			1
Circular scraper				2			2
End and side scraper				1			1
Burin		1		1			2
Microlith		3		2			5
Backed blade		1					1
Leaf-shaped arrowhead				1			1
Misc. retouched	1	1					2
Serrated blade				1			1
Notched flake		1					1
Edge trimmed flake				2			2
Irregular core				1	1		2
Single platform flake core	1	2		1			4

Type/Land Parcel	LP 6	LP 7a	LP 7b	LP 7c	LP 8	Unprovenanced	Totals
Two platform flake core				1			1
Multiple platform flake core		2		1			3
Single platform blade/let core		7		2			9
Two platform blade/let core	1			1			2
Multiple platform blade/let core		1					1
Opposed platform blade/let core		5		1			6
Keeled core		2					2
Discoidal core		1		1			2
Core fragment					1		1
Minimally worked core		2		2			4
Core on flake		2		1			3
Hammerstone				1			1
<b>Total worked</b>	<b>50</b>	<b>881</b>	<b>20</b>	<b>319</b>	<b>42</b>	<b>9</b>	<b>1321</b>
Unworked burnt flint weight (g)	5518	12653	275	15909	389	92	34835

Table 5. Basic quantification of flint by land parcel

## Methodology

- B.4.3 The assemblage was catalogued directly onto an Excel spreadsheet and the artefacts were classified according to a system of broad artefact/debitage types based on standard definitions for post-glacial lithic assemblages from southern Britain (e.g. Bamford 1985, 72-77; Healey 1983, 48-9; Butler 2005; Ballin 2021). Additional information on selected non-metric attributes of the material (including extent of dorsal cortex coverage, breakage and condition) was also recorded using standard classifications and terminology, alongside free text notes where appropriate. No detailed technological or metric analysis has been undertaken at this stage. A full copy of the resulting catalogue is retained in the project archive.

## Provenance and recovery

- B.4.4 Overall the flint assemblage derived from 88 of the trenches excavated across Land Parcels 6, 7a, 7b, 7c and 8 and was recovered from a diverse range of contexts. The assemblage is quantified by simplified context type in Table 6, and Table 7 shows a breakdown of flint from these context types from each of the land parcels.
- B.4.5 The most significant element of the worked flint assemblage are the relatively large numbers of flints (755, 57.2% of the assemblage) derived from *in situ*/minimally disturbed scatters encountered in a small number of trenches, mostly in Land Parcel 7a (classified as 'Other layer' in Tables 6 and 7). This material was largely recovered

from silt rich layers overlying or representing the eroded surface of Pleistocene deposits on the valley floor and were sampled through surface collection (with the location of individual finds usually being three-dimensionally recorded), accompanied, in most cases, by the excavation of a small number of 1mx1m test pits, which were carefully hand excavated by spit, with individual finds three-dimensionally located and with a programme for sieving for the recovery of smaller pieces. Differences in the intensity of sampling strategies in different trenches should be borne in mind when interpreting differences in the composition and character of the flint assemblages from these *in situ* scatters, especially in terms of the much greater proportion of smaller pieces from excavation of the test pits when compared to surface collection.

B.4.6 The remainder of the assemblage was generally either recovered during hand excavation of excavated features or through collection of material from topsoil, subsoil and colluvial deposits. Further details and discussion of the provenance of the material from each Land Parcel are provided below.

Context type	Worked flint		Unworked burnt flint	
	Count	%	Weight, g.	%
Alluvium	13	1.0	295.7	0.8
Buried soil	23	1.7	1033.6	3.0
Colluvium	71	5.4	345.7	1.0
Feature	338	25.6	29231	83.9
Natural	15	1.1	250.3	0.7
Other layer	755	57.2	3362.9	9.7
Subsoil	24	1.8	15.2	0.0
Topsoil	65	4.9	208.2	0.6
Unstratified	17	1.3	92.4	0.3
<b>Total</b>	<b>1321</b>	<b>100.0</b>	<b>34835</b>	<b>100.0</b>

Table 6. Basic quantification of flint by simplified context type

Land Parcel	Context type	Worked		Unworked burnt	
		Count	%	Weight, g.	%
LP 6	Alluvium	2	4.0		0.0
	Buried soil	6	12.0	739	13.4
	Colluvium	31	62.0	181	3.3
	Feature	7	14.0	4591	83.2
	Natural	1	2.0		0.0
	Subsoil		0.0	7	0.1
	Topsoil	2	4.0		0.0
	Unstratified	1	2.0		0.0
	Sub-total	50	100.0	5518	100
LP 7a	Colluvium	13	1.5	33	0.3
	Feature	102	11.6	9251	73
	Other layer	741	84.1	3363	27
	Subsoil	11	1.2		0
	Topsoil	8	0.9	6	0
	Unstratified	6	0.7		0
	Sub-total	881	100.0	12653	100

Land Parcel	Context type	Worked		Unworked burnt	
		Count	%	Weight, g.	%
LP 7b	Buried soil	11	55.0	199	72
	Colluvium	7	35.0		0
	Feature	1	5.0	76	28
	Topsoil	1	5.0		0
	Sub-total	20	100.0	275	100
LP 7c	Alluvium	6	1.9	296	1.9
	Buried soil	6	1.9	96	0.6
	Colluvium	20	6.3	132	0.8
	Feature	206	64.6	15174	95
	Natural	7	2.2		0
	Other layer	10	3.1		0
	Subsoil	13	4.1	8	0.1
	Topsoil	50	15.7	202	1.3
	Unstratified	1	0.3		0
	Sub-total	319	100.0	15909	100
LP 8	Alluvium	5	11.9		0
	Feature	22	52.4	138	36
	Natural	7	16.7	250	64
	Other layer	4	9.5		0
	Topsoil	4	9.5		0
	Sub-total	42	100.0	389	100
Unprovenanced	Unstratified	9		92	

Table 7. Basic quantification of flint by simplified context type and land parcel

## Raw materials and condition

B.4.7 The entire assemblage is made up of flint. Variation in the character of surviving cortical surfaces and the colour and texture of the flint hint at a variety of sources, but there was no material with the kind of fresh unweathered cortex that would suggest procurement direct from the parent chalk. Most common were the kind of rounded, abraded thin cortical surfaces typical of cobbles collected from fluvial gravels, but pieces struck from nodular pieces, often with thermally fractured surfaces, were also present. Bullhead flint – readily identifiable on the basis of its green/grey cortex with underlying orange band - was a minor but persistent feature of the assemblage, with 19 pieces identified, all from the two largest assemblages from Land Parcels 7a and 7c. Sources of flint would have been available relatively locally, including on the extensive gravel terraces to the east of the evaluated area, whilst the contact between the Thanet sands and the chalk, where the Bullhead flint originates, is located little more than 1.5km south of the site.

B.4.8 As discussed in more detail in relation to individual contexts/assemblages below, the condition of the assemblage was varied and bore a close and generally predictable relationship to its depositional context. The vast majority of the flintwork derived from the *in situ*/minimally disturbed scatters in Land Parcel 7a could be described as in 'good' or 'fresh' condition, with damage limited to occasional minor edge damage and with good preservation of even very thin, feathered edges. At the other extreme, material from topsoil and subsoil deposits was often in 'moderate' or 'worn' condition, with worn edges and more frequent, sometimes severe, edge damage. The material

from cut features was much more variable – some was in good condition analogous to the flint from the scatters, whilst other flints were in notably poorer condition. Given that most of the flintwork from features seems to be residual, these differences probably reflect differences in the depositional pathways which led to their incorporation into the features, with the fresher material probably often reflecting the direct incorporation of material previously contained in well-preserved *in situ* scatters into the fills of later features cut through them.

- B.4.9 Cortication ('patination') was very rare, although light to moderate cortication (generally a light blue sheen/clouding) was recorded on a very few pieces: it does not appear to be of chronological significance. Potentially slightly more common was a subtle mineral staining, only obvious when recent breaks or chips on some pieces revealed the original colour of the flint, but this too appears to have been rare.

### **Land Parcel 6**

- B.4.10 A total of 50 worked flints and 5518g of unworked bunt flint were recovered from Land Parcel 6 (Table 5), deriving from 16 trenches (Trenches 3, 17, 20, 27, 28, 29, 30, 31, 32, 33, 40, 42, 46, 49, 50 and 51). The majority of the worked flint was derived from colluvial deposits (31 pieces/62%), recovered in low densities (1-10 pieces per trench) from Trenches 20, 27, 30, 31, 32, 46 and 49. This material was made up exclusively of irregular waste and unretouched removals, and although blades and bladelets were present in small numbers (six pieces), many of the removals were simple hard-hammer struck flakes consistent with a later Neolithic or Bronze Age date, and the flint gives the impression of a mixed, multi-period assemblage. A broken flake and a lightly burnt single platform flake core were also recovered from an alluvial deposit in Trench 51 (5103).
- B.4.11 In Trenches 31 and 33, flints were recovered from probable buried soils associated with or sealed by these colluvial deposits, but only in very small numbers. In Trench 33 a bulk sample (121) of buried soil 3305 produced eight small fragments of unworked burnt flint (73g), whilst a larger assemblage of burnt flint (627g) and six flakes, none in very fresh condition, were collected from buried soils 3104/3106. A single flake was also recovered from the surface of the natural geology in Trench 3 (314).
- B.4.12 Aside from these buried soils, an extensive spread of burnt flint and charcoal-rich sediment (4005) in Trench 40, possibly lying within a shallow hollow (4004), was bulk sampled, producing a large assemblage of heavily burnt flint (4550g) consisting of small fractured chunks: very few measure in excess of 50mm in maximum dimension and none display any traces of having been worked prior to heating.
- B.4.13 Several other cut features in Land Parcel 6 produced small quantities of worked and/or burnt flint (pits 321, 1704, 4205 and 4903 and ditch 2806); the worked flint consisted entirely of unretouched flakes, recovered in low densities (one to three pieces pre context) and is likely to represent residual material. A further three worked flints and a single unworked burnt flint were recovered from topsoil and subsoil deposits.

### **Land Parcel 7a**

- B.4.14 A total of 881 worked flints and 12653g of unworked burnt flint were recovered from Land Parcel 7a, making up almost exactly two thirds (66.7%) and just over a third (36.3%) respectively of the total numbers of worked and burnt flint recovered from



the evaluation as a whole (Table 5). The flint was recovered from 24 trenches (Trenches 68, 69, 77, 79, 82, 84, 89, 90, 91, 92, 94, 95, 96, 97, 98, 99, 100, 101, 102, 103, 104, 105, 107 and 109), with the vast majority of worked flint derived from sampling of *in situ*/minimally disturbed scatters in the south-east corner of this land parcel, and much smaller numbers derived from cut features, topsoil/subsoil deposits and other contexts (Table 7).

### Lithic scatters (Table 8)

B.4.15 The lithic scatters were identified as lying within a series of silt-rich deposits, often sealed by colluvial deposits, preserved across the valley floor, with significant flint assemblages deriving from these contexts in Trenches 97, 98, 99, 103, 104, 105, 107 and 109 (Table 8). The numbers of flints recovered for these trenches varied significantly, partly depending on the intensity of sampling/collection in the different trenches, but also clearly relating to real differences in the density of lithic material across the area. The material from each of the trenches summarised in Table 8 is discussed individually below, but in general terms the flintwork from these contexts were comparable in terms of their very good, fresh condition - suggesting they derive from *in situ* or at least minimally disturbed scatters - and are overwhelmingly dominated by Mesolithic material, reflected very clearly in the high blade index of all of the assemblages (see Table 8; blade index =blades and bladelets as a percentage of all unretouched removals) and the presence of diagnostically Mesolithic types (e.g. microliths, micro-burin, axe/adze sharpening flake) and a dearth of typologically later retouched forms.

Trench	97	98	99	103	104	105	107	109
<b>Contexts</b>	<b>9703, 9705</b>	<b>9802, 9809, 9810</b>	<b>9901</b>	<b>10312</b>	<b>10402</b>	<b>10503</b>	<b>10705, 10708, 10709</b>	<b>10901, 10902, 10908</b>
Chip	7		14	16	127	9		1
Irregular waste	6		1	2	7	2	1	1
Flake	47	1	46	22	143	30	14	14
Blade	23	2	17	6	33	11	4	4
Bladelet	9		16	4	27	6	3	
Blade-like flake	4	1	5		6	1	1	
Core tablet					1		1	
Crested blade/flake	3		1		1			1
Axe/adze sharpening flake							1	
Microburin	1							
End scraper		1	1	1		1		
Burin					1			
Microlith				1	2			
Backed blade					1			
Notched flake					1			
Single platform flake core							1	
Multiple platform flake core						1	1	

Trench	97	98	99	103	104	105	107	109
Contexts	9703, 9705	9802, 9809, 9810	9901	10312	10402	10503	10705, 10708, 10709	10901, 10902, 10908
Single platform blade/let core				1	3			
Multiple platform blade/let core							1	
Opposed platform blade/let core	1				1		1	1
Keeled core								
Discoidal core			1					
Minimally worked core	1		1					
Core on flake					2			
<b>Total worked</b>	<b>102</b>	<b>5</b>	<b>103</b>	<b>53</b>	<b>356</b>	<b>61</b>	<b>29</b>	<b>22</b>
Unworked burnt weight, g.	712.5	0	76.9	23	2330.5	136.6	0	32.9
Blade index (% of removals)	37.2	50	38.8	31.25	28.4	35.4	29.2	21.1

Table 8. Flint from major lithic scatters in Land Parcel 7a

- B.4.16 In Trench 97, surface collection and the excavation of a single 1m by 1m test pit (EAA) recovered a total of 102 worked flints and 712g of unworked burnt flint from deposits 9703 and 9705, with the majority of the worked flint deriving from the test pit (78 pieces) and the surface finds deriving from close by, in the southern half of the trench. This assemblage is dominated by unretouched removals, with a high proportion of blades and bladelets (blade index of 37.2%) and including several partly crested blades. Cores were restricted to a single opposed platform blade core and a minimally worked cobble fragment. Retouched tools were entirely absent but a double (medial) microburin (the characteristic by-product of Mesolithic microlith manufacture) was recovered as a surface find (SF 148) within the cluster of finds in the southern half of the trench.
- B.4.17 In Trench 98, analogous deposits to those recorded in Trench 97 produced only a very small quantity of worked flint, five pieces, but including two fine blade fragments of probable Mesolithic date. Also present is a broad end scraper (SF 483), which although not strongly diagnostic, is perhaps more likely to be of Neolithic or early Bronze Age date.
- B.4.18 An assemblage of 103 worked flints and 77g of unworked burnt flint was recovered from silt layer 9901 in Trench 99, with 53 flints collected from the surface of the south-eastern end of the trench and 50 worked flints coming from a 1m by 1m test pit (DAA) excavated within this area of surface finds. The assemblage has a high blade index of 38.8%, and includes a large number of narrow bladelets and a part crested blade. The only cores present are, however, flake cores - a minimally worked core and an elongated keeled/discoidal core which may in fact represent a failed/preform core

tool. The only retouched tool form is a very fine end scraper made on a large blade (68mm long; SF 517).

- B.4.19 Layer/scatter 10312 in Trench 103 produced a total of 53 worked flints, through surface collection (29 pieces) and the excavation of a single 1m by 1m test pit (24 pieces; test pit BAA). This scatter seemed to have a relatively low density of finds compared to some of the other scatters but had a comparably high blade index (31.3%) and produced a blade core and two retouched tools. The tools consisted of a broken end scraper, with minimal distal retouch applied to a primary (decortication) flake (SF 400), and a broken narrow-blade microlith – the medial portion of a narrow bladelet (10mm long, 7mm wide) fully backed along its left lateral edge (test pit BAA; SF 398).
- B.4.20 Trench 104 produced the largest individual assemblage from the flint scatters investigated in Land Parcel 7a, with 356 worked flints and 2331g of unworked burnt flint deriving from layer 10402. The distribution of surface finds suggests two main clusters of flints located in the western and eastern ends of the trench, with three test pits each 1m by 1m being excavated at various points along the trench: ABA (114 worked flints), ACB (94 worked flints) and AFC (61 flints). At 28.4%, the overall blade index of the assemblage from this trench was slightly lower than those from some of the other larger scatters in Land Parcel 7a (see Table 8) but this partly relates to the large number of small broken fragments in the assemblage, reflecting the high proportion of this material collected during careful hand excavation of the test pits (note also the relatively high proportion of chips). Six cores were present, including three single platform and one opposed platform blade/let cores, and rejuvenation/core maintenance flakes, including a core tablet and a partly crested blade, were also recovered. Retouched tools were rare, with five pieces accounting for 2.2% of the assemblage (excluding chips) but were dominated by diagnostically Mesolithic types. Two microliths were recovered: a very small micro-scalene triangle/four-sided piece (SF 8; retouched on all three sides and across the base, left lateralised, 13mm long x 6mm wide) and the broken medial segment of a bladelet with backing along its left lateral edge (SF 263, ABA; 29mm long x 9mm wide). A third piece, classed here as a backed bladelet, could also be classed as a microlith: the proximal portion of the bladelet is fully backed along its left lateral edge (SF 17; 17mm long x 9mm wide). Also present is a probable burin on a break, made on a flawed, partly cortical flake (SF 222, ABA), and a flake fragment bearing two closely set notches on one edge (SF 291, ABA).
- B.4.21 A total of 61 worked flints alongside 17g of unworked burnt flint, were recovered from analogous contexts in Trench 105. Here, a single test pit (CAA) excavated in the western end of the trench produced 26 flints, with the remaining 35 worked flints being collected as surface finds. The assemblage is again dominated by unretouched removals, including many small fragments, and has a high blade index of 35.4%. The only core recovered is a small multiple platform flake core (21.2g) and the only tool is a large core trimming flake with some minimal abrupt retouch at its distal end, forming a convex scraper edge.
- B.4.22 A small but distinctive assemblage of 29 worked flints was recovered from equivalent layers in Trench 107. The surface density of flint in this trench appears to have been relatively low, and no test pits were excavated - with the collection of material exclusively through surface collection probably accounting for the predominance of larger pieces (including four cores). This flintwork includes a high proportion of the

kind of small regular blades and bladelets that are a feature of the scatters across the evaluated area (blade index of 29.2%), but does include several unusually large blades, including one complete blade measuring 110mm long by 24mm wide (SF 315). This piece bears traces of platform faceting and it is possible that it belongs to a late Upper Palaeolithic industry. No retouched tools were present, but a significant find is a large axe/adze sharpening flake; this appears to be a 'primary' sharpening flake in that it does not carry the scar of a previous transverse removal, and was struck to create a broad cutting edge, which would have measured some 77mm wide. The four cores recovered from this trench include two somewhat irregular/minimally worked flake cores alongside a multiple platform blade/let core and a fine opposed platform blade/bladelet core.

B.4.23 Surface collection of artefacts from the silt deposits in Trench 109, immediately to the east of Trench 104, produced 22 worked flints. This small assemblage included a high proportion of blades and bladelets (blade index 32.9%) including a partly crested blade and a relatively large blade (75mm long) struck from an opposed platform core and carrying clear traces of use along one lateral edge. No retouched tools were found, and the only core was a fairly minimally reduced opposed platform blade/let core.

### Other contexts

B.4.24 A relatively small assemblage of worked flint, 102 pieces, derived from cut features in Land Parcel 7a, alongside a substantial assemblage of 9251g of unworked burnt flint (Table 9). The worked flints derived from 18 separate features/interventions in 14 trenches. The majority of these features produced very small quantities of flint (one to four pieces), and in most cases this is very likely to represent residual material, but somewhat larger assemblages of flintwork were recovered from three features: pit 9410 (19 flints), ditch 9806 (37 flints) and ditch 10403 (17 flints).

Trench	Cut	Feature type	Chip	Irregular waste	Flake	Blade	Bladelet	Blade-like flake	Single platform flake core	Single platform blade/let core	Opposed platform blade/let core	Keeled core	Total worked	Unworked burnt wt, g.
67	6703	Pit												123.7
68	6805	Ditch			2							1	3	
69	6904	Ditch						1					1	
77	7710	Ditch												30.9
79	7909	Tree Throw	1		1	2							4	
90	9013	Ditch			1								1	
92	9215	Pit						1					1	
94	9410	Pit	1		13	5							19	
94	9415	Pit												4.7
96	9603	Ditch			1			1					2	

96	9606	Pit			1							1	
98	9806	Ditch		5	18	6	4	2	1		1	37	6
100	10013	Pit								1		1	
101	10103	Pit			1							1	
101	10105	Ditch	2	1								3	24.1
101	10107	Ditch	1		2	1						4	
102	10208	Ditch			1							1	32.5
102	10214	Pit				1						1	9
102	10216	Pit											1.6
104	10403	Ditch	1	1	12	2	1					17	8946.2
104	10407	Other Cut											72.5
107	10700	Pit			1							1	
107	10723	Posthole			2		2					4	

Table 9. Flint from cut features in Land Parcel 7a

B.4.25 The assemblage from pit 9410 (Trench 94) is made up exclusively of unretouched removals, including a relatively high proportion of blades and bladelets, and the relatively poor condition of this material strongly suggest it is residual, probably ultimately deriving from the disturbance of scatters analogous to the *in situ*/minimally disturbed scatters in this land parcel described above. The slightly larger assemblage of 37 worked flints from ditch 9806 are in somewhat better condition, but this too seem likely to represent residual material derived from disturbance of *in situ* scatters in this trench and has a high blade index (33.3%) and includes a fine opposed platform blade core. The flintwork from ditch 10403 also seems likely to derive ultimately from the relatively dense scatters of flint recorded in this trench (see above), although it includes few distinctive pieces. More significant is the very large quantity of unworked burnt flint derived from this feature – 8946g – made up of small heavily featured chunks, none of which showed clear signs of prior working.

B.4.26 The remainder of the flintwork from Land Parcel 7a derived from poorly stratified contexts including colluvial deposits (13 pieces; Trenches 82, 89, 91, 102, 107), the topsoil (eight pieces; Trenches 77, 95, 97, 99, 104 and 109) and subsoils (11 pieces; Trenches 100 and 104). Little of this material is distinctive, but blade-based pieces are well-represented and they include a very large proximal blade portion from the topsoil of Trench 99 and two single platform blade/bladelet cores, from the subsoil of Trench 100 and a colluvial deposit in Trench 82 (8204).

### Land Parcel 7b

B.4.27 In contrast to Land Parcel 7a, a very small assemblage of 20 worked flints and 275g of unworked burnt flint was recovered from Land Parcel 7b (Table 7), most of which derived from colluvial deposits and a buried soil in Trench 113, with a very small number of flints coming from features and poorly stratified (topsoil/colluvial) deposits in Trenches 120, 123, 125, 126, 127 and 129.

B.4.28 A total of 16 worked flints were recovered from Trench 113, five from colluvial deposit 11302 and eleven from buried soil 11303. Despite their different depositional contexts the flint from both contexts was in comparable, good/fresh condition and the presence of two flakes from the colluvium which seem very likely to derive from the same nodule of material also suggests that much of this flintwork has witnessed minimal disturbance. The worked flint is made up entirely of unretouched removals but includes a high proportion of blades/bladelets (five pieces: 31.2%) and seems in

general terms to be comparable to the *in situ*/minimally disturbed scatters investigated in land Parcel 7a.

### **Land Parcel 7c**

- B.4.29 A total of 319 worked flints and 15909g of unworked burnt flints was recovered from Land Parcel 7c. Few of the worked flints derive from the kind of *in situ*/minimally disturbed scatters sampled in Land Parcel 7a, with the majority deriving from the fills of cut features and poorly stratified deposits including topsoil and colluvial deposits (Table 7).
- B.4.30 Small quantities of flint were recovered from two possible buried soil deposits identified in this land parcel. In Trench 141, deposit 14104 produced four simple hard-hammer struck flakes likely to be of Neolithic or later date. These were not in fresh condition and seem likely to have experienced a degree of post-depositional disturbance. Two flakes were also recovered from buried soil 16501 in Trench 165, alongside a small quantity of burnt flint (96g).
- B.4.31 A small assemblage of possible *in situ* flintwork was collected from 'natural' deposit 17620 (Trench 176). The seven worked flints from this context are in fresh condition and include a broken blade and a possible burin (a broad blade-like flake that has had potential burin spalls removed from its proximal end). This material is consistent with a Mesolithic date.
- B.4.32 Almost two thirds of the worked flint from Land Parcel 7c and a substantial quantity of unworked burnt flint derived from cut features (Table 10). The worked flint derived from a total of 36 features, many of which produced only very small quantities of material. The most substantial and significant assemblages derived from natural features 13810, 13911, 14109, all found in trenches in the very northern part of the land parcel, which produced what appear to represent essentially single-period Mesolithic assemblages. As discussed below, flintwork was also recovered from topsoil and colluvial deposits in Trenches 138 and 139, and some of this is likely to be broadly contemporary with the material from these features.
- B.4.33 The 16 worked flints from natural feature 13810 are generally in good/fresh condition. They include several blades alongside flakes which clearly derive from a blade-based technology, and the only retouched tool is the broken proximal portion of a microlith, a slender obliquely blunted point (left lateralised; >21mm long and 11mm wide), with some possible impact damage at its tip.
- B.4.34 An assemblage of 59 worked flints was recovered from tree-throw hole 13911. This was dominated by unretouched removals, alongside a minimally worked irregular core, and had a very high proportion of blades and bladelets (blade index 40.8%) and includes the distal portion of very large blade (119mm long and 44mm wide) This piece qualifies as a 'long blade' (grosse Klinge) and may be of late Upper Palaeolithic date, a possibility strengthened by its corticated/lightly mineral-stained condition, contrasting with some of the fresher material from this feature. A single microlith was only retouched tool; in very fresh condition this is a slender bladelet (45mm long by 9mm wide), fully backed along one lateral edge (right hand side) with its proximal end having an inverse oblique truncation accompanied by additional ancillary inverse retouch. This is an unusual form, and although in plan the resulting form is akin to an elongated scalene triangle, the character of the inverse retouch at its proximal end suggests an affiliation with inverse basally-retouched points of 'middle Mesolithic;' Honey Hill type (Saville 1981a, 1981b; Reynier 2005; Cooper and Jarvis 2017).

- B.4.35 The 31 worked flints recovered from natural feature 14109 were less distinctive and the only retouched tool was a simple edge trimmed and utilised flake, but it included a reasonably high proportion of blades and bladelets (blade index 29.2%) consistent with a Mesolithic date.
- B.4.36 The remaining 95 flints from cut features in Land Parcel 7c were derived from 35 individual interventions/features in 19 trenches and were thinly distributed (one to eight flints per feature). Collectively, the flintwork from these features had a significantly lower proportion of blades and bladelets than the essentially single-period Mesolithic assemblages from elsewhere on the site (blade index 12%), suggesting that this material includes a greater proportion of later, Neolithic and Bronze Age material. This is also suggested by the character of the simple hard-hammer struck flakes that feature strongly among this material and, more significantly, by the character of the small number of retouched tools recovered from some of these features. Ditch 19612 (Trench 196) produced only two flints, but both were tools, consisting of an earlier Neolithic leaf-shaped arrowhead and a small end and side scraper. A fine, extensively worked, circular scraper of probable later Neolithic or early Bronze Age date was recovered alongside a small piece of irregular waste and non-cortical flake from pit 14107 (Trench 141). The distal end of a serrated blade/microdenticulate, with fine, closely set notches along both lateral edges, was recovered from ditch 17516. Such serrated pieces are found in both Mesolithic and Neolithic assemblages but are especially common in many earlier Neolithic assemblages. Other distinctive pieces include a discoidal/Levallois-like core – probably of later Neolithic date (Ballin 2011) - from pit 16103 (Trench 161), where it was found alongside a chip and a broken fully cortical flake.
- B.4.37 Despite the presence of later, Neolithic and Bronze Age, flintwork among this material, there is an absence of substantial coherent assemblages, and it seems likely that the vast majority of this material is residual flintwork caught up incidentally in the fills of later features. The burnt flint was similarly thinly distributed, with the signal exception of a pit (13808) in Trench 138, close to natural feature 13810 (see above), which produced only small assemblage of eight worked flints (all simple flakes and not in fresh condition) alongside a very large amount of unworked burnt flint, with some 11,200g coming from the residues of a bulk sample (sample 190).
- B.4.38 The remaining flintwork from Land Parcel 7c derived from poorly stratified deposits including topsoil, subsoil, and alluvial and colluvial deposits. In most cases it occurred in very low densities and did not include any distinctive/diagnostic elements. More substantial assemblages of worked flint were, however, recovered from topsoil deposits in Trenches 138 (16 pieces) and 139 (21 pieces), whilst colluvial deposits in Trench 139 (layers 13901, 13902 and 13903) produced a further ten worked flints. As noted above, some of the flints from these deposits are likely to be contemporary with those from natural features in Trenches 138 and 139. The assemblage is dominated by unretouched removals, with blades and bladelets well-represented but at levels somewhat lower than that seen in the single-period Mesolithic assemblages from the site (blade index 22.9%), suggesting a major later, Neolithic/Bronze Age, contribution to this material, probably including the only two retouched tools recovered, both scrapers made on small hard-hammer struck flake blanks (one each from the topsoil of Trench 138 and 139). Both flake cores (three pieces) and blade/bladelet cores (two pieces) are also present in this assemblage from these deposits – emphasising its chronologically mixed character.

Trench	Fill of	Context type	Chip	Irregular waste	Flake	Blade	Bladelet	Blade-like flake	Core tablet	Crested blade/flake	Circular scraper	End and side scraper	Microlith	Leaf arrowhead	Serrated blade	Edge trimmed flake	Irregular core	Single platform blade/let core	Discoidal core	Minimally worked core	Total worked	Burnt unworked wt., g.
138	13808	Pit			7			1													8	13300
138	13810	Natural Feat	1	3	9	2							1								16	3.2
138	13813	Pit			1																1	
139	13904	Pit			2	1		1													4	25.1
139	13911	Tree Throw	9	4	24	13	7	4	1				1				1				64	33
140	14003	Pond			2																2	44.5
141	14107	Pit		1	1						1										3	
141	14109	Natural Feat	2	3	16	5	2	1								1				1	31	30.4
150	15003	Ditch	1		6	1												1			9	
150	15005	Ditch																		1	1	
151	15106	Pit	1																		1	
151	15108	Ditch			3																3	
151	15115	Ditch			1																1	
151	15119	Ditch			1																1	17.2
152	15204	Ditch			3																3	12.5
159	15903	Pit		1				1													2	2.3
161	16103	Pit	1		1														1		3	44.5
162	16205	Ditch																				4.9
163	16309	Ditch			2																2	
163	16311	Ditch				1															1	0.7
163	16315	Tree Throw		1	5	1		1													8	
167	16710	Tree Throw			2																2	
167	16713	Tree Throw			1																1	
175	17503	Ditch		2	2	1															5	30
175	17509	Ditch			2																2	
175	17516	Ditch			2									1							3	



Trench	Fill of	Context type	Chip	Irregular waste	Flake	Blade	Bladelet	Blade-like flake	Core tablet	Crested blade/flake	Circular scraper	End and side scraper	Microolith	Leaf arrowhead	Serrated blade	Edge trimmed flake	Irregular core	Single platform blade/let core	Discoidal core	Minimally worked core	Total worked	Burnt unworked wt., g.
176	17604	Pit						1													1	1355
176	17611	Ditch				1															1	
176	17613	Ring Ditch			1					1											2	
176	17615	Grave Cut	1		1	1	1	1								1					6	
176	17616	Other Cut			1	1															2	9.4
178	17807	Pit																				70.8
180	18004	Ditch			1																1	
182	18203	Ditch		2																	2	43.2
184	18416	Ditch			1																1	
185	18513	Ditch		1	2																3	118.2
185	18520	Ditch																				20
190	19003	Ditch																				9.1
196	19602	Ditch			3																3	
196	19606	Ditch			4																4	
196	19612	Ditch										1		1							2	
213	21303	Ditch			1																1	

Table 10. Flint from cut features in Land Parcel 7c

## Land Parcel 8

- B.4.39 Trenches in Land Parcel 8 produced a total of 42 worked flints and 389g of unworked burnt flint, thinly distributed across contexts in nine trenches (Trenches 229, 230, 233, 234, 235, 237, 239, 240, 241). The worked flint is overwhelmingly dominated by unretouched removals (with one core, one core fragment and no retouched tools), and largely derived from the fills of cut features where it seems likely to represent residual material (Table 7).
- B.4.40 A total of 22 worked flints were recovered from eleven cut features (mostly ditches: features/interventions 22903, 23005, 23008, 23412, 23414, 23503, 23506, 23703, 23903, 24005, 24103) most of which produced one to three flints, with the exception of ditch 23008 which produced nine flints including four fine blades. A small number of flints, in good condition and perhaps representing minimally disturbed scatters, were recovered from layer 22912 in Trench 229, comprising four unretouched removals including a partly crested blade almost certainly of Mesolithic date, and from 23002, the 'natural' in Trench 230, comprising seven unretouched removals including a single blade. Five pieces, including an irregular flake core, were also recovered from alluvial deposit 23410 in Trench 234 and four pieces including two blades from the topsoil of Trench 230.

## Discussion

- B.4.41 Even considering the extensive scale of the trial trenching, the flint assemblage can be regarded as relatively large, and clearly indicates the potential of the area for the recovery of substantial and regionally significant lithic assemblages. The most significant element of the flint assemblage is clearly the material recovered from deposits found preserved on the lower south side and the valley floor in Land Parcel 7a. These silt layers were widely recognised in this part of the site, with significant flint assemblages coming from Trenches 97, 98, 99, 103, 104, 105 107 and 109. Although none of the assemblages from these trenches could be considered large (with the largest coming from Trenches 97, 99 and 104, with 102, 103 and 356 worked flints respectively), the recovered material derives from fairly minimal sampling of the flint bearing deposits. By way of example, the surface collection carried out in Trench 99 indicates that the main scatter of flint covers at least an area of approximately 20m<sup>2</sup>. Given that 50 flints were recovered from a single test pit 1m square excavated within this scatter (Test Pit DAA) it is possible that full excavation of this deposit, within the confines of the trench alone, could produce around 1000 worked flints. Larger quantities are likely from further excavation in the area of Trench 104, where the density of worked flints from an individual test pit reached 114 (Test Pit ABA).
- B.4.42 Although at this stage it has not been possible to undertake any concerted attempts at refitting to examine the spatial integrity of the scatters, and with observations clearly based only on a very partial sample of material, the condition and composition/character of the assemblages from these deposits do suggest that they represent coherent, essentially *in situ* scatters within which artefacts have seen minimal horizontal displacement. Equally importantly, the flintwork from the scatters from each of the trenches give every impression of very largely representing chronologically unmixed assemblages, as suggested by the few strictly diagnostic forms - all of Mesolithic date - coupled with the very high proportions of blade-based material. Whilst this this need not indicate that each of the scatters/assemblages from the trenches represent single episodes of activity (an issue which can only be resolved through further, more extensive excavation), it does strongly imply that

material from these deposits is overwhelmingly Mesolithic in date. This said there is, of course, potential for both earlier and later material to be present in these scatters as a minority element and the possibility of an earlier, late glacial/late Upper Palaeolithic presence is hinted at by the presence of a large blade with faceted platform preparation from Trench 107, whilst later material may include a scraper from Trench 98.

- B.4.43 In terms of characterising and dating the Mesolithic activity represented by these scatters, the relatively small size of the individual assemblages renders any interpretations tentative. In general terms, however, the assemblages seem broadly typical of Mesolithic scatters from elsewhere across Southern and Eastern England, and more locally from the few comparable sites in Essex (see below), in terms of attesting to large scale flintworking, with all stages of core reduction represented and with a small and restricted tool kit dominated by microliths alongside occasional scrapers and burins, with a single sharpening flake from a transverse axe/adze attesting to the use/maintenance of core tools. The presence of burnt flint (both worked and unworked) indicates that many of the scatters may have included hearths/fire settings, and overall the scatters probably attest to relatively short-lived occupations.
- B.4.44 In terms of chronology, the scatters yielded very few microliths/allied forms, consisting of three microliths, and a backed bladelet. Two of the microliths and the backed bladelet were recovered from Trench 104: the backed bladelet and one of the microliths are simple pieces with straight backing along one lateral edge and fall into the category of narrow straight backed bladelets whilst the third microlith is a very small scalene triangle with a narrow squared off base – which could thus also be classed as a four-sided piece. In very broad terms, the narrow backed bladelet (as distinct from bilaterally backed late Mesolithic ‘rod’ microliths, cf. Griffiths 2014) are of a kind common throughout the later part of the Mesolithic of Southern Britain (i.e. c 7000-4000 BC), and include some examples with very late (5th millennium cal BC) radiocarbon dates, such as those from Lydstep, South Wales (Jacobi 1980a, fig. 4.25; Hedges *et al.* 1989). The small scalene triangle is more distinctive and belongs to the groups of very small microliths often argued to belong to the final two millennia of the period (e.g. Barton and Roberts 2004) and can be compared to the series of small triangular microliths from Broxbourne site 105, Hertfordshire (Switsur and Jacobi 1979, fig. 7; Jacobi 1994), associated with a radiocarbon date straddling the late 7th and earlier 6th millennium cal BC. Aside from Trench 104, the only other scatter to produce a microlith was that from Trench 103, again a fragment of a probable narrow backed bladelet. Notwithstanding that a larger sample of microlithic forms would be required to provide a confident date in typological terms, the forms are entirely consistent with a broad later Mesolithic date.
- B.4.45 Aside from the scatters in Land Parcel 7a, very small quantities of potentially *in situ*/minimally disturbed flint in fresh condition were recovered from buried soils in Trench 113 (Land Parcel 7b), and the ‘natural’ substrate in Trench 176 (Land Parcel 7c) and Trench 229 (Land Parcel 8). These were all very small assemblages, in themselves of limited significance, but suggest the potential for preservation of *in situ* scatters elsewhere in the evaluated area.
- B.4.46 The high proportion of blade-based material analogous to that from the main scatters in Land Parcel 7b deriving from other contexts right across the evaluated area, including the fills of cut features, colluvial deposits and topsoils/subsoils, strongly

suggest that Mesolithic activity was widely distributed across other parts of the evaluated area, although the potential and significance of this material - poorly stratified and invariably mixed with later flintwork, is low. The most significant traces of Mesolithic activity not associated with the scatters in Land Parcel 7b were several assemblages from tree-throw holes/natural features in the northern part of Land Parcel 7c (features 13810, 13911, 14109). Although small, these appear to represent relatively coherent Mesolithic assemblages. The mechanism for their incorporation into the natural features is unclear. It is possible that they were deliberately deposited into 'open' natural features; alternatively these features may have incorporated material from surrounding surface scatters that have subsequently been truncated, so that the only surviving material occurs in topsoil/subsoil and colluvial deposits and within the fills of these features. Two microliths were recovered from them: an unusual backed point with proximal inverse retouch from 13911 and a broken obliquely blunted point from feature 13810. As described above, the inversely retouched backed point may find its closest affinities with 'middle Mesolithic' Honey Hill type microliths forms – as yet poorly dated but probably belonging to a period covering the very late 9th and 8th millennia cal BC (Cooper and Jarvis 2017; Conneller *et al.* 2016), whilst the obliquely blunted point is a form and size most readily associated with Early (e.g. Deepcar type) or 'middle' Mesolithic assemblages and probably pre-dates the 7th millennium BC (Reynier 2005; Conneller *et al.* 2016). Whilst the small number of microliths again encourages caution, this provides hints that the Mesolithic activity at the site may have extended over a considerable timescale incorporating the early/middle and late parts of the period.

- B.4.47 The Mesolithic scatters revealed by the evaluation are of considerable regional significance. As with many other parts of Eastern England, until recent years the record of Mesolithic activity in Essex was dominated by assemblages collected under uncontrolled or *ad hoc* conditions, as surface finds or from poorly documented investigation of better-preserved sites (see Jacobi 1980b, 1996). In recent years this has begun to change as developer-funded excavations have investigated several sites where relatively undisturbed Mesolithic flint scatters have been preserved under the alluvial deposits of the lower Thames valley, most notably at Tank Hill Road, Purfleet (Leivers *et al.* 2007), and Dagenham (Champness *et al.* 2015), which bear comparison with well-preserved late Upper Palaeolithic and Mesolithic sites known from tributaries of the Thames further to the west, in Hertfordshire and Middlesex (e.g. Lewis and Rackham 2011). In the context of the very small number of high integrity Mesolithic sites yet sampled in the county, the potential of the scatters revealed by the evaluation are of considerable potential in terms of representing well preserved scatters which further investigation and detailed analyses would be able to characterise in considerable detail, providing important evidence for the chronology and organisation of Mesolithic settlement and land use in this landscape, and new insights with which to better interpret the poorly stratified assemblages of flintwork which make up the bulk of the record of Mesolithic activity in Eastern England.
- B.4.48 Although the flint assemblage from the evaluation does include a proportion of later, Neolithic and early Bronze Age material, at this stage there do not appear to be any major, coherent, assemblages of later prehistoric date from individual features/deposits. As noted above, there is little indication of such material in the *in situ* scatters sampled across the area (although depending on the geomorphological history of the valley sediments there may be potential for preservation of later prehistoric scatters in some locations) and no features of this date associated with significant flint assemblages were identified. Nonetheless, the presence of Neolithic-

early Bronze Age flintwork as a component of the material recovered from topsoils, subsoils and colluvial deposits, and as a residual element from later features does indicate activity across the site and includes some diagnostic/distinctive artefacts – most notably the leaf shaped arrowhead from ditch 19612 (Trench 196). In this context the potential for features associated with episodes of Neolithic and early Bronze Age activity, such as pits, could be expected to be present in some parts of the site.

## B.5 Fired Clay

By Kirsty Smith

### Introduction

B.5.1 A large quantity of fired clay amounting to 272 fragments weighing 4560g was recovered from Trenches 3, 4, 15, 69, 79, 89, 92, 94, 96, 138, 151, 167, 173, 175, 176, 178, 184, 185, 190, 191, 196, 234, 235, 237, 238 and 239. The assemblage consists of small and medium sized fragments, with the majority poorly preserved and abraded with a mean fragment weight of 16.8g. Only one fragment can be dated as Roman, and that is the perforated pedestal from context 19605. Three fragments of possible triangular oven brick were also recorded from context 9607 and these can tentatively be dated to the later Iron Age or early Roman period. The rest of the assemblage of fired clay is more fragmentary and cannot be dated due to an absence of diagnostic material. The assemblage is summarised in Tables 11 and 12 below and has been more fully recorded on an Excel spreadsheet in accordance with guidelines set out by the Archaeological Ceramic Building Materials Group (ACBMG 2007), which whilst not specifically for fired clay provide appropriate guidance. Fabrics were characterised on the basis of macroscopic features supplemented by the use of x20 hand lens for finer constituents.

### Fabrics

B.5.2 The fired clay was made from two different fabrics. The first was an orange coarse quartz sand (code Qc for quartz/coarse). This fabric had quartz grits up to 0.5mm long and red iron oxide grits up to 0.5mm long. A smaller proportion were made from this coarse material but also had cream clay pellets up to 7mm long and cream laminations. A second type was much finer, and this comprised a fine silty clay fabric within few inclusions (code AS for argillaceous/smooth/silty). The site is underlain by a bedrock of Thanet Sand with superficial bands of head clay and Boyn Hill Sand and Gravel. The local clay deposits are probably weathered from a mixture of the head clays and gravels, producing some variation.

### Description

B.5.3 The majority of the fired clay was undiagnostic amorphous fragments which were up to 25mm long. The indeterminate fragments accounted for 198 out of a total of 270 fragments. These fragments had no distinctive features and no original surfaces.

B.5.4 Around 25% of the fragments (68), but almost half the weight (2136g) had evidence of a burnt blackened surface or grey discolouration indicating proximity to a heat source. This category had a higher mean fragment weight of 31.4g and a handful of these fragments had one or more rough surfaces surviving.

B.5.5 The majority of the fired clay is probably structural in origin from oven or hearths of a domestic character or for crop processing. Structures may have been set into a natural clay surface and burnt *in situ*.

B.5.6 Only four fragments may be portable oven or hearth furniture, and these comprise the perforated plate or pedestal from context 19605 and three fragments of possible triangular bricks from context 9607.

B.5.7 The perforated plate from context 19605 has a thickness of 79mm and is 70+mm wide and 86+mm long. It forms the edge of flat plate with rounded edge in cross

section more bulbous at the top. It was made from an orange/cream coarse quartz sand with quartz grits up to <0.5mm and chalk grits up to 2mm long. This plate has a flattish upper surface which has been shaped with finger marks. The bottom surface is rough but is abraded and incomplete. The plate has a semi-circular perforation in the middle 36mm diameter (50%) complete. It also has one roughly curved edge with a rounded lip towards the upper surface which may have formed part of a vent. The vent hole would have a complete diameter of around 130mm. This plate would have formed part of the suspended floor of a pottery kiln and is Roman in date.

- B.5.8 Three probable triangular brick fragments were recorded from context 9607. The fragments were 30-50mm thick and up to 61mm wide. One appears to be part of a corner of a triangular brick and the other two may also have been part of the edge of the same brick, although none of the fragments joined. One has an organic impression 5mm wide and 41mm deep. Each fragment has a burnt grey core but there are also some areas of surface burnt grey. These fragments may be middle Iron Age to early Roman in date.

Context	Count	Weight (g)	Fabric	Form	Comments
320	37	96	Qc	Indet	
402	2	7	Qc	Indet	
1511	2	15	Qc	Indet	
6905	1	6	AS	Indet	
7907	33	92	Qc	Indet	
8901	2	11	AS	Indet	
9226	5	16	Qc	Indet	
9407	7	136	Qc	Indet	
9407	35	759	Qc	Indet	
9421	2	4	Qc	Indet	
9607	3	290	AS	Triangular brick	Three large frags. Possibly all part of the same triangular brick
13809	3	10	Qc	Indet	
15107	4	46	Qc	Indet	
15112	4	14	Qc	Indet	
15116	4	87	Qc	Structure - oven?	
15120	1	16	Qc	Indet	
16714	2	2	AS	Indet	Half of each burnt black
17301	1	2	Qc	Indet	
17510	2	35	Qc	Indet	
17606	56	1796	Qc	Structure - oven?	Around 20% show signs of burning on one or more surfaces.
17609	1	4	Qc	Indet	
17802	3	16	Qc	Indet	
17806	6	36	Qc	Indet	
17808	4	56	Qc	Indet	
17811	4	42	Qc	Indet	Burnt dark red
17816	6	9	Qc	Indet	
17821	2	13	Qc	Indet	One burnt black on one side

Context	Count	Weight (g)	Fabric	Form	Comments
18401	1	4	Qc	Indet	
18417	3	9	Qc	Indet	
18515	3	6	Qc	Indet	
18517	2	24	Qc	Indet	Large frag has burning on one rough surface
18519	2	10	Qc	Indet	
19006	4	18	Qc	Indet	Amorphous frags - burning on largest
19113	3	62	Qc	Indet	Large frag has burning on one rough surface
19605	1	406	Qc	Perforated plate	Has half of a circular perforation in the middle 36mm diam. Has one curving edge of a circular or oval vent hole. Upper surface has been roughly shaped and has finger marks. Lower part of the plate is discoloured dark brown
23411	1	19	Qc	Indet	burnt black
23504	2	15	Qc	Indet	burnt black
23507	2	13	Qc	Indet	
23507	2	70	Qc	Structure - oven?	
23704	6	183	Qc	Structure - oven?	Large frags all have dark grey burning on the inside
23807	3	24	Qc	Indet	
23904	3	56	Qc	Indet	One frag burnt black
Unstratified	2	5	Qc	Indet	
<b>Total</b>	<b>272</b>	<b>4560</b>			

Table 11: Summary of fired clay assemblage

Form	Nos	Weight (g)
Indeterminate	198	1701
Perforated plate	1	406
Structure - oven?	68	2136
Triangular bricks (kiln furniture)	3	290
<b>Total</b>	<b>270</b>	<b>4533</b>

Table 12: Summary of fired clay by form

## Conclusion

- B.5.9 The majority of the fired clay was recovered from ditches and pits with a handful of fired clay received from colluvial layers and natural features. Around half the weight of the assemblage consists of moderate to large fragments that were burnt or discoloured. In terms of function, the fired clay is most likely to derive from domestic oven or hearth structures, crop processing ovens or pottery kilns.
- B.5.10 Trenches 3 and 15 were located at the north-western edge of the site and the fired clay from Trench 3 came from a natural feature. Fired clay was also recorded in Trenches 69, 79, 89, 92, 94 and 96 located south-east of Hoford Road. These trenches were located close to a rectilinear enclosure recorded from the aerial



photographic survey and encountered in Trenches 68, 75, 76, 77, 78. Most of the fired clay from these trenches was amorphous except for three fragments of triangular brick from pit 9606 in Trench 96 (context 9607). It is possible these may have been used for a long period of time as they are worn and may have continued to be used after breaking. Triangular perforated bricks are commonly described as loomweights, but an association with oven structure and burnt debris has been observed at many sites and an alternative function as oven or hearth furniture has been suggested (Poole 1995). As portable items they are commonly discarded in pits or ditches, but occasionally have been found in ovens or pottery kilns or discarded with kiln debris. Clear evidence for use as pedestals in salt working was found at East Kent Access (Poole 2015), but most were probably used in a domestic setting. Triangular perforated bricks occur throughout the Iron Age and continued in use at least into the early Roman period and possibly even into the middle or late Roman period at some sites.

- B.5.11 Another cluster of features containing fired clay were pits and ditches within the southern part of the site (Trenches 151, 167, 173, 175, 176, 178, 184, 185, 190, 191, 196) and south-eastern part of the site (Trenches 234, 235, 237, 238 and 239). Most of the fired clay from these trenches was undiagnostic and undatable apart from the large and significant fragment of kiln furniture from the fill (19605) of ditch 19604. This is a perforated plate which would have formed the suspended floor in a Roman pottery kiln. The perforations would have allowed the hot air to rise from the lower firing chamber to the upper chamber containing the pottery to be fired. It was suggested at Orsett Cock that the floors of the upper chambers of the kilns were probably 'solid clay floors with vents' (Major 1988, 70) though no actual examples were found, only a small number of broken fragments with perforations. The four kilns at Orsett Cock were dated to the late 2nd to the 4th century AD (Carter, 1998, 62). The presence of this kiln structure strongly suggests there may be Roman pottery kilns in the vicinity of Trench 196, especially given the good state of preservation of this plate.
- B.5.12 A number of Roman pottery kilns have been recorded within several kilometres the site. Six bottle neck shaped structures were found during quarry works 500m north of Trench 196 in 1955. These structures were destroyed by gravel extraction before they could be recorded (Barton 1962, 57-104). Six Roman kilns were recorded during the Mucking excavations located 1.3km north-east of the site (Jones and Rodwell 1973, 13-47). Three Roman pottery kilns were recorded at Gun Hill located 1.7km south-west of the site (Drury and Rodwell 1973, 48-112). As mentioned above, four pottery kilns were recorded at Orsett Cock in 1976 located 2.6km north-west of Trench 196 (Carter 1998). This site appears to have been a regional area for pottery production on a large scale during the Roman period. It is possible that a number of smaller fragments of fired clay may have come from the inner linings of pottery kilns.

## **Recommendations**

- B.5.13 The assemblage is moderate in size but contains a significant quantity of fragments of fired oven or kiln debris. This together with the Roman perforated plate and Iron Age/Roman triangular bricks makes this a significant assemblage. There is substantial evidence of Roman kilns in the vicinity of the site as excavations at Linford, Mucking, Gun Hill and Orsett Cock have indicated. This suggests there may be further Roman kilns in the area of the site and further excavations should mitigate for the possibility of encountering the structures and associated kiln furniture.

B.5.14 The smaller undiagnostic, indeterminate elements can be discarded but the possible oven fragments, perforated plate and triangular bricks should be retained for further research potential.

## B.6 Ceramic Building Material

By Kirsty Smith

### Introduction

B.6.1 A total of 23 fragments of ceramic building material (CBM) weighing 4232g was recovered from Trenches 5, 48, 89, 90, 101, 116, 173 and 229. The assemblage contains one whole brick and several large fragments of brick and has a high mean fragment weight of 200g as a result. The assemblage includes two pieces of Roman date, but otherwise consists overwhelmingly of later medieval/post-medieval material. The assemblage has been fully recorded on an Excel spreadsheet in accordance with guidelines set out by the Archaeological Ceramic Building Materials Group (ACBMG 2007). The record includes quantification, and details of fabric type, form, surface finish, markings and evidence of use/reuse (mortar, burning etc). Fabrics were characterised on the basis of macroscopic features supplemented by the use of x20 hand lens or binocular microscope at x25 for finer constituents and have been assigned Museum of London fabric codes (MoLA 2014b & c). The assemblage is summarised by number, weight, date, fabric and form in Table 13.

### Fabrics

B.6.2 Six different MOLA fabric types were observed within the assemblage. The assemblage was compared to the MOLA fabric series held at Oxford Archaeology and associated catalogues of the fabric series (MoLA 2014a & b). The fabrics included:

- MoL3060: an orange fine silty fabric. Occ quartz <0.2mm; moderate fine black iron oxides <0.1mm (contexts 501, 11601)
- MoL2271: an orange red sandy fabric. Hard, well fired fabric with fine texture, occasional coarse quartz <0.6mm, occasional calcium carbonate and red iron oxide <0.5mm, occasional muscovite mica <0.05mm (context 4804)
- MoL2276: an orange moderately fine silty fabric. Hard, well fired fine texture with few visible inclusions, occasional quartz <0.6mm, occasional calcium carbonate and red iron oxide <0.5mm (contexts 4810, 10113, 17301)
- MoL3033: an orange-red fine sandy, with occasional dark red iron oxide inclusions <5mm (contexts 4810, 8903, 10110)
- MoL3034: an orange-red fine sandy, with occasional dark red iron oxide inclusions <5mm (context 10113)
- MoL3042: Maroon with fine yellow speckling, occasional sandy lenses, quartz <0.6mm and occasional calcium carbonate inclusions <1.5mm. Black iron oxides up to 6mm long (context 22904)
- MoL3047: a fine sandy red-orange fabric, moderate quartz <0.4mm, dark red iron oxides <6.0mm, fine quartz moulding sand <0.1mm on outside surface (context 9005)

### Roman tile

B.6.3 Roman tile comprised one fragment of tegula (47g) from context 501 and a flat tile fragment (13g) 13mm thick from context 11601. Both fragments were probably made

from fabric MoL3060 as they contained fine black iron oxides. The tegula was 17mm thick and 62mm+ wide and the flange was incomplete. It may have originally had a rectangular flange profile with a curved internal base angle (profile A1) with a finger groove alongside the flange on the flat section of the tile. There was no cutaway surviving.

- B.6.4 The tegula fragment comes from a colluvial layer in Trench 5 at the north-western end of the site. The flat tile also comes from a colluvial layer in Trench 116 in the central part of the site. It is possible these fragments of tile fragment may well be associated with nearby Roman settlements, although the small amount may indicate that the fragments represent incidental discard, probably as a result of agricultural practices.

### **Medieval - post-medieval CBM**

- B.6.5 Medieval - post-medieval roof tile was recorded in Trenches 48, 101 and 173. Post-medieval brick was recorded in Trenches 48, 89, 90, 101 and 229.
- B.6.6 Roof tile (10 fragments, 318g) was made from MoL2276 and included two fragments of peg tile and six fragments of flat tile. The peg tile and roof tile measured 12-15mm thick, with an average of 13mm. The peg tile from context 17301 had two partial square peg holes (one per tile) and one flat tile had two rough edges and a corner. One of the peg holes was 8mm wide along one of the edges of the hole, the other hole was incomplete. The six fragments of flat roof tile from contexts 4810 and 10113 had only four rough edges and no corners. The flat tile almost certainly originated as peg tile. The peg tile from context 17301 can be dated to the late 15th-17th century based on the fabric and the square peg holes, which tend to be restricted to the late medieval to early post-medieval period. The flat tile from contexts 4810 and 10113 has a broad date of the late 15th to the 19th century. Two fragments (14g) of highly abraded roof tile made from fabric MoL2271 were recorded in context 4804. This fabric dates from the medieval and post-medieval period.
- B.6.7 Brick (11 fragments, 3854g) was all hand made with rough surfaces, with some creasing of the edges. One brick (2698g) was complete from context 9005 and was made from fabric MoL3047 with fine quartz moulding sand <0.1mm on outside. This brick was 66mm (3 inches) thick, 110mm (4½ inches) wide and 230mm (9 inches) long. It has a small frog in the top surface, which was 116mm long, 30mm wide and 6mm deep. The sides of the brick were quite straight compared to the other bricks and so it may have been made using a metal mould, indicating a probably 19th century date.
- B.6.8 A brick fragment (573g) from context 22904 was maroon in colour with fine yellow speckling which characterises fabric MoL3042. This fragment was 62mm (2½ inches) thick and 104mm (4¼ inches) wide and 89mm+ long. It had one end edge and two rough side edges. This fabric is dated to the 15th-19th century, but this brick is more likely to date to towards the end of this broad date range.
- B.6.9 Brick from three contexts (4810, 8903, 10110) was made from fabric MoL3033 and was heavily abraded and were mostly amorphous scraps. Only the brick from 10110 had edges and this included one worn end edge and two very abraded side edges. This brick did not have any complete dimensions. Three fragments of heavily abraded brick from context 10113 were made from fabric MoL3034. These fragments had only one side edge and one surface on two different pieces. These fragments can only be given a broad post-medieval date as they have few diagnostic elements.

Context	Count	Weight (g)	Spot date	Form	Fabric	Comments
501	1	47	Roman	MoL3060?	Tegula	Flange Type A1, finger groove next to flange. No cutaway
4804	2	14	Med-Pmed	MoL2271	Roof (flat)	
4810	5	186	LC15-CL19	MoL2276	Roof (flat)	Four rough edges. Flat tiles
4810	3	45	Pmed	MoL3033	Brick	
8903	1	6	Pmed	MoL3033	Brick	
9005	1	2698	Pmed: (prob 19th)	MoL3047	Brick	Complete brick. Has a basic handmade frog 116mm long, 30mm wide and 6mm deep on top surface. Sides quite straight - metal mould?
10110	2	346	Pmed	MoL3033	Brick	
10113	3	186	Pmed	MoL3034	Brick	
10113	1	33	LC15-CL19	MoL2276	Roof (flat)	
11601	1	13	Roman?	MoL3060?	Flat (RB)	
17301	2	85	LC15-C17	MoL2276	Roof (peg)	Two partial square peg holes.
22904	1	573	C15-19	MoL3042	Brick	
<b>Total</b>	<b>23</b>	<b>4232</b>				

Table 13: Summary of CBM assemblage by number, weight, date, form and fabric

## Conclusions

- B.6.10 The two Roman fragments of tile were both recorded from colluvial layers (501, 11601) and therefore it is difficult to pinpoint exactly where the material may have come from. Given the large number of Roman settlements in the vicinity of the site it is surprising that more Roman material was not represented in the assemblage.
- B.6.11 The majority of post-Roman assemblage can only be dated broadly to the post-medieval period, and it comprises amorphous heavily abraded fragments of brick and flat roof tile. There appears to be a small grouping of post-medieval brick and tile from Trenches 48, 90 and 101, which are trenches located either side of Hoford Road. This includes the whole brick with a small frog from context 9005, which may date to the 19th century. It is possible these fragments may have originated from a house located near this road. However, the late 19th century OS maps do not show any buildings in this vicinity.
- B.6.12 The two fragments of peg tile from the subsoil in Trench 173 can be dated to the late 15th-17th century based on the presence of the square holes. These fragments were

located in Trench 173 located south of Highash Shaw. The nearest building to this on the later 19th century maps is Becksland Farm located 300m south-west of Trench 173. This farm may be shown on the 1777 Map of Essex and therefore the peg tile may have originated from this farm. A large fragment of later post-medieval brick was recovered from a ditch in Trench 229. The later 19th century maps do not show any buildings in the vicinity of this trench.

### **Recommendations**

- B.6.13 The fragment of Roman tegula should be retained as it may relate to Roman settlement in the vicinity of the site. The complete brick from context 9005 should be retained along with the large fragment of brick from context 229. The early post-medieval peg tile with square holes from context 17301 should also be retained. The post-Roman assemblage provides supplementary dating evidence and tentative evidence of post-medieval structures in the vicinity of the site. The material has little additional intrinsic research value and in general, the archive record should be sufficient in any wider research encompassing the site or the material.

## B.7 Briquetage

By Alex Davies

### Introduction

B.7.1 Briquetage from salt production was found in three contexts (4904, 4905, 4907) in Trench 49 along with a tiny scrap in context 4902. Some 70 pieces were found, weighing 339g (Table 14). None of the pieces are particularly intrinsically datable, although contexts 4904, 4905 and 4907 were associated with reasonable quantities of late Bronze Age pottery, and a late Bronze Age date for the briquetage is entirely in keeping with the morphology of the assemblage. Similar late Bronze Age material has been found at Mucking nearby (Barford 1988; 2016).

### Methodology

B.7.2 All the information recorded is presented on Table 14. There is no further data or metadata. The main reports used for comparison were those upon the large assemblages from London Gateway (Poole 2012) and the A2 (Morris 2012), and vessel coding and types followed those used in these reports.

### Fabrics

B.7.3 Fabrics were coded using the same method as the prehistoric pottery. Fabrics were recorded in order of their approximate frequency in any one context. The two most common inclusion types were noted, using the following fabric codes:

- FI - Flint
- Qs - Quartz sand
- Ve - Vegetal (grass/chaff voids)

B.7.4 The grade of the fabric was also recorded with a number suffix, ranging from 1 (fine) to 4 (very coarse).

B.7.5 All but one of the sherds are in a fine vegetal and sand fabric (VeQs1). This appears broadly the same as the briquetage fabric found at LTC Land Parcel 37, just over 1km to the south-east (OCA 2021b). It is similar to fabric B at Mucking, in which the majority of the late Bronze Age briquetage there was made, although flint was also present in the Mucking fabric (Barford 2016). The material in fabric VeQs2 is pink/red in colour, with some grey tones.

B.7.6 A single sherd is in sand and flint fabric QsFI2. This was more like to the associated pottery fabrics, and the colour of this piece is a lighter orange than the pink/red that characterises the rest of the briquetage. It is a rim sherd from context 4905. This may be pottery, although it has a pressed or pinched rim similar to that found at London Gateway (Poole 2012, fig. 8.2.1, 3, 5, 13, 17), and is of open flared form (form V2: Poole 2012, 5) making it more likely that it is a piece of briquetage vessel.

### Forms and function

B.7.7 Sherds from vessels dominate the assemblage, and where diagnostic most of these are of open, flared form, indicating that they belong to evaporation vessels or containers (form V2: Poole 2012, 5; or R1-2: Morris 2012, 237). Two vessel forms are slightly closed bowls, one with a slight bead rim (form R4: Morris 2012, 237). The

vessel sherds are 6-13mm thick and have an occasional cream-coloured veneer (salt residue). At least one curved base is also present.

- B.7.8 A single pedestal piece was found, in context 4905. This is by far the largest piece of briquetage, weighing 67g. This is of form PD3/PD16, conforming to Poole's (2012, 8) medium sized group as it has a diameter of *c* 70mm, and survives to a height of 70mm although neither of the ends are present.
- B.7.9 A less usual piece was found in context 4904. This is flat with one side curving vertically upwards to an internal length of 7mm. The curving side has a surface on the top showing that it is not a broken base sherd from a vessel comparable to others illustrated from the assemblages at London Gateway (Poole 2012) or the A2 (Morris 2012). These sites are, however, later than LTC7L as they include Iron Age and Roman material. The fragment might be an incurving rim from a rectangular trough. It is similar to late Bronze Age pieces described as 'angles' at Mucking (Barford 2016, fig. 3.34.11). Alternatively, it may be from a very shallow tray or dish. A cream-coloured veneer is present on the internal and external surface.
- B.7.10 Three very small pieces (6g) of possible structural material were found in context 4907. A 15g hand-squeezed lump (Poole 2012, 11) is also present.

Context	Count	Weight (g)	Fabric	Comment
4902	1	2	VeQs1	?Vessel body sherd
				11x (59g) from vessels: 6-12mm thick. 1x rim – V2 flared vessel (Poole 2012) or R1 (Morris 2012). 1x curved base. 2x cream veneer. 1x (15g) from trough/tray/'angle' (?) 10mm thick base, 7mm internal wall. Cream veneer on internal and external surface. 1x (8g) uncertain curving piece. Could be vessel base or tray/angle
4904	13	82	VeQs1	Inc. some from sample 73
				12x (71g) from vessels: 7-13mm thick. 4x rims – 2x V2 flared vessel (Poole 2012) or R1-2 (Morris 2012) – one pinched rim in fabric QsFI2; 2x R4 closed bowls with slightly bead rim (Morris 2012). 1x body sherd with cream veneer. 1x (67g) pedestal PD3/PD16 (Poole 2012): <i>c</i> 70mm diameter, surviving to 70mm. Only outer surface, no ends. 1x (4g) miscellaneous
4905	14	142	VeQs1, QsFI2	
				38x (90g) from vessel: 8-12mm. All body sherds, 4x with cream veneer. 1x (15g) hand squeezed lump (Poole 2012) 3x (6g) miscellaneous, structural material or very abraded vessel sherds
4907	42	113	VeQs1	
	<b>70</b>	<b>339g</b>		

Table 14: Quantification of briquetage by context

## Discussion

- B.7.11 The assemblage of briquetage found in Trench 49 is modest, meaning only limited information can be gleaned from it. Vessels dominate, although a pedestal was also found. The pedestal and the presence of cream-coloured veneer suggests that at least some of the assemblage derives from salt production itself, rather than being simply containers or moulds used in the transportation of processed salt, although



moulds are likely to also be present in the group. No certain structural material was discovered, although the significance of this is uncertain given the limited area the evaluation trench sampled. Contexts 4904, 4905 and 4907 are fills of pit 4903 that was not bottomed; context 4902 is a colluvial layer. The deposit in pit 4903 does not contain material from an oven or hearth structure, but this might be found elsewhere in the area nearby. By way of comparison, at London Gateway, vessels comprised 59% of the assemblage, pedestals and related pieces (furniture) totaled 11%, and oven structure amounted to 17% (Poole 2012).

## **Recommendations**

- B.7.12 The assemblage should be retained and reconsidered alongside any further material, should excavation take place. Bronze Age briquetage is not common and any further excavation should carefully consider the possibility of early saltworking. For example, evaporating hearths might be present that are ephemeral and slight. Any features that could related to saltworking should be fully excavated and fired clay sampled from *in situ* structures in addition to collection of other briquetage.

## B.8 Clay Pipe

By John Cotter

### Introduction and methodology

- B.8.1 Six pieces of clay pipe weighing 20g were recovered from three contexts. Given the small amount this has not been separately catalogued, and is fully described below.
- B.8.2 For the London area, pipe bowls are assigned form codes based on Atkinson and Oswald's (1969) London pipes typology with bowl types assigned to an abbreviated code (eg. AO22).

### Description

- B.8.3 Context (10108) Spot-date: c 1820-1860. Description: 4 pieces (weight 8g). Fresh, broken bowl profile (3 joining pieces) from a standard 19th-century spurred pipe bowl (AO28). The bowl has vertical ribbed decoration with moulded oakleaf seams, front and back. The spur bears the maker's initials 'I/S' in relief. A short length of stem still attached. Also, 1x fresh slender 19th-century stem fragment in a whiter clay than the bowl.
- B.8.4 Context (10503) Spot-date: First half of the 17th century. Description: 1 piece (weight 4g). Early style 'chunky' stem fragment (length 49mm). Large stem bore diameter (3mm). Fairly abraded.
- B.8.5 Context (16610) Spot-date: c 1780-1830. Description: 1 piece (weight 8g). Complete pipe bowl (AO27) with a spur of squared outline. The rim has a slight internal bevel ('bottered') where knife-trimmed or smoothed-off with the finger – particularly at the front where the wall is quite thick. The mould seam is untrimmed and prominent. Moulded decoration similar in style to the bowl in (10108) (a common 19th-century style) with vertical ribbing and oakleaf seams front and back. The spur bears the maker's initials 'P/B' in relief. Stub of stem still attached. Good condition apart from slight chip to the rim.

### Recommendations regarding the conservation, discard and retention of material

- B.8.6 The pipes here have potential for further study. Further research may allow the makers to be identified (probably London or Essex) and the bowls to be dated more precisely. They should therefore be retained.

## B.9 Metals

By Anni Byard

### Introduction and methodology

- B.9.1 A total of 14 metal objects (19 fragments) weighing 408.4g were recovered from 7 contexts across 5 trenches. Most of the metalwork comprises iron (10 objects, 403.3g), plus two copper alloy objects (3.2g) and two fragments of lead alloy (1.9g). The material is mostly post-medieval / modern in date except for the remains of a 1st century AD Roman brooch.
- B.9.2 All the metalwork was scanned during the present assessment and where possible assigned to a century or broad period date. Objects were quantified by type count and weight by context and recorded in an excel spreadsheet with a summary of the assemblage presented in Table 15 below.

### Results

- B.9.3 Trench 3 produced four iron objects and one of copper alloy, all from context 326. The iron comprises two nails and the oval head of a key, probably dating to the post-medieval or early modern period (c 1600-1900). A small copper alloy lace tag / lace chape recovered from the same context is likely of late medieval or early post-medieval date (c 1500-1800).
- B.9.4 Trench 9 yielded a single heavy iron disc of uncertain function but probably of modern date. No attachments, rivets or piercings were visible.
- B.9.5 Trench 101 produced six iron objects from four contexts. Context 10104 produced a fragment of a probable later medieval or post-medieval knife blade plus a heavily corroded and encrusted bar-shaped object of uncertain use. Context 10108 produced a single nail fragment while context 10114 produced a bent nail or other fitting and two corroded fragments of an encrusted iron sheet/s of uncertain function or date.
- B.9.6 Trench 238 produced a single copper alloy object, now in four pieces. The object is part of the head and bow of a Roman brooch, probably a Langton Down style brooch dating from c AD 25-60. This is the earliest metal object recovered during the evaluation. Langton Down brooches are found across south-east England.

Context	Material	Count	Frag count	Weight	Use	Date	Description
326	Cu alloy	1	1	1	Dress	Med	Lace chape. Rolled, tapering cone, open at wider end. c AD 1200-1600
326	Fe	2	2	15.5	Nail	PM / Mod	Two nails, one retains round head. PM / Emod
326	Fe	1	1	13.1	Key	PM / Mod	Oval loop and part of hollow shank from a key.
900	Fe	1	1	268	Query	Mod	Heavy circular, convex disc, no holes / attachment seen. 1/2 lb weight; Machinery? Lid? Needs x-ray
10104	Fe	1	3	20.1	Query	Query	Encrusted and corroded thin shaped bar object

Context	Material	Count	Frag count	Weight	Use	Date	Description
10104	Fe	1	1	8.4	Knife	Med / PM?	Probable knife blade fragment, Med / PM?
10108	Fe	1	1	4	Nail	Query	Nail shank fragment
10114	Fe	1	1	12.7	Nail	Query	S-shaped (angular) nail
10114	Fe	2	2	61.5	Query	Query	Two corroded and encrusted double sheeted fragments, uncertain use or date
23807	Cu alloy	1	4	2.2	Brooch	1st C AD	Possible Langton Down style brooch, very fragmentary, only part of tubular spring casing and top of bow survives, AD 25-60
Unstratified	Pb alloy	2	2	1.9	Waste	Query	Two linear droplets of lead, undatable.

Table 15: Metalwork assemblage

### Recommendations regarding the conservation, discard and retention of material

- B.9.7 The Roman brooch fragment should be retained. Otherwise, the archive record should be sufficient for any wider research encompassing the site or the material, therefore isolated nails and objects of post-medieval / modern date could be disposed of after they have been x-rayed.

## **B.10 Glass**

By Anni Byard

### **Introduction**

B.10.1 The evaluation yielded a single piece of glass weighing 26.4g.

### **Results**

B.10.2 A single shard of olive-green wine bottle glass was recovered from Trench 101, context 10110. The shard dates from the later 18th to early 19th century.

### **Recommendations regarding the conservation, discard and retention of material**

B.10.3 The glass is of recent date and has been catalogued as part of this report. This record is therefore sufficient, and the glass does not need to be retained and can be discarded.

## B.11 Worked Stone

By Ruth Shaffrey

### Results and Discussion

- B.11.1 A single large piece of tufa is the only stone that was retained. This was found in the basal fill (9407) of a medieval pit. It appears to have been roughly shaped into an approximate block measuring 23 x 27 x 9cm (3451g). One surface of this block is slightly dished and smoothed in places. As the nature of tufa is to be very open textured with large holes, this rock would not have been suited to any sort of grinding or food processing anything that would break down into small particles. It may have been part of a surface, which also results in wear.
- B.11.2 It is not easy to say where the tufa came from, but it forms around springs and in streams.

### Recommendations regarding the conservation, discard and retention of material

- B.11.3 The stone should be retained.

### C.1 Environmental Samples

By Richard Palmer

#### Introduction

- C.1.1 Eighty-eight bulk samples were recovered from a variety of deposits across the evaluation primarily for the retrieval and assessment of charred plant remains and the recovery of any bones or artefacts. Selected deposits were also sampled for the recovery of waterlogged plant remains, to provide material suitable for pollen and soil analysis if warranted (soil monoliths) and for Optically Stimulated Luminescence dating (OSL). These are reported separately.
- C.1.2 A single inhumation was also excavated on site and several samples were taken from both the grave fill and the locations of individual skeletal elements.

#### Method

- C.1.3 The bulk samples, except for sample 142, were processed in their entirety at Oxford Archaeology using a modified Siraf-type water flotation machine. The flots were collected in a 250µm mesh and residues in a 500µm mesh and dried. The residue fractions were sorted by eye and with the aid of a magnet while the flot material was sorted using a low power (x10) binocular microscope to extract cereal grains and chaff, smaller seeds and other quantifiable remains. As a peaty, potentially waterlogged deposit, sample 142 was sub-sampled and 2 buckets processed as above with an additional 1L processed for the assessment of waterlogged material (see report by Cook, below).
- C.1.4 Charcoal identifications were made using a high power (x50 to x400) microscope to identify diagnostic features.
- C.1.5 Nomenclature for identified species follows Stace (2010). Cereal and chaff identifications are made with reference to Jacomet (2006) and charcoal identifications with reference to Schweingruber (1990).
- C.1.6 Samples taken from the inhumation were wet sieved to 2mm and the residues dried and sorted by eye with any extracted material considered as part of the osteological assessment.

#### Results

- C.1.7 Sample size and flot abundance data is presented in Table 16. Many of the samples contained the burrowing mollusc *Cecilioides acicula* which has not been quantified in the table since it is likely to be intrusive. Identified charcoal is listed in Table 18 and the inhumation samples summarised in Table 17.
- C.1.8 **Trench 3.** Sample 102 from colluvial layer 326 produced a small flot. Charcoal fragments are common, and the recovered grains are wheat (*Triticum* sp.). A copper alloy fragment/object was recovered from the residue.
- C.1.9 **Trench 8.** Sample 12 from fill 804 of pit 803 produced a small flot. Charred goosefoot seeds (*Chenopodium* sp.) are present. No artefacts were recovered from the residue.

- C.1.10 **Trench 9.** Sample 13 from fill 904 of pit 903 produced a small flot. The majority of the flot consists of modern roots and other plant debris but a probable charred speedwell seed (*Veronica* sp.) is present. The possible recorded grain is a single specimen that whilst mostly intact cannot be identified further. No artefacts were recorded from the residue.
- C.1.11 **Trench 17.** Sample 11 from fill 1704 of pit 1703 produced a small flot. The recovered charcoal was mostly hand-collected from the residue which also produced some pottery.
- C.1.12 **Trench 26.** Sample 85 from buried soil 2604 produced a poor flot with a small number of charcoal fragments. No artefacts were recovered from the residue.
- C.1.13 Sample 86 from layer 2614 produced a small flot. Apart from charcoal a likely charred speedwell seed was identified. No artefacts were recovered from the residue.
- C.1.14 **Trench 33.** Sample 121 from buried soil 3305 produced a poor flot. The recorded charcoal was mostly hand-recovered from the residue along with some burnt flint.
- C.1.15 **Trench 40.** Sample 76 from fill 4005 of cut 4004 produced a small flot. Charcoal is the dominant component of the flot and recorded grain consists of an indeterminate fragment. A large quantity of burnt flint was recovered from the residue.
- C.1.16 **Trench 42.** Sample 21 from fill 4206 of pit 4205 produced a modest charcoal-dominated flot. Flint and fired clay were recovered from the residue.
- C.1.17 **Trench 48.** Sample 197 from fill 4806 of pit 4805 produced a poor flot and no artefacts were recovered from the residue.
- C.1.18 **Trench 49.** Sample 73 from fill 4904 of pit 4903 produced a small flot. Some of the charcoal is of ring-porous type and a probable wheat grain is also present. Pottery and fired clay were recovered from the residue.
- C.1.19 **Trench 67.** Sample 87 from fill 6704 of pit 6703 produced a poor flot. The charcoal includes at least one twig fragment and burnt flint and pottery were recovered from the residue.
- C.1.20 **Trench 79.** Two samples were taken from tree-throw hole 7909 (samples 199 and 198) from fills 7907 and 7908 respectively. Both samples produced poor flots with small quantities of charcoal and most of the volume consisting of modern roots and fine sediment. Flint was recovered from the residues of both samples with a large quantity of fired clay also recovered from fill 7907, sample 105.
- C.1.21 **Trench 90.** Sample 27 from layer 9008 produced a poor flot and no artefacts were recovered from the residue.
- C.1.22 **Trench 92.** Sample 4 from colluvial layer 9204 produced a poor flot and no artefacts were recovered from the residue.
- C.1.23 **Trench 94.** Sample 18 from fill 9407 of pit 9404 produced a modest flot. The charred grain is a mix of cereals with wheat, barley (*Hordeum vulgare*) and oat (*Avena* sp.) all represented. Charred seeds of bedstraw (*Galium* sp.) are also present along with several small legumes. Pottery and fired clay were recovered from the residue.
- C.1.24 Two fills (9421 and 9422) of pit 9415 were sampled (samples 28 and 29 respectively). Sample 28 is the larger and more diverse of the two flots with wheat and small



legumes present in both. Charred bedstraw, speedwell and grass (Poaceae) seeds are present in sample 28 along with some fragments of rachis. Burnt flint and fired clay were recovered from sample 28 and pottery was recovered from sample 29.

- C.1.25 **Trench 95.** Sample 118 from layer 9505 produced a poor flot with the recorded charcoal being hand-recovered from the residue which contained no artefacts.
- C.1.26 **Trench 96.** Sample 42 from fill 9607 of pit 9606 produced a large charcoal-dominated flot. Preliminary identifications of the charcoal indicate a mix of diffuse- and ring-porous types present with oak (*Quercus* sp.), elm (*Ulmus* sp.) and hazel (*Corylus avellana*) being noted as present. Alder (*Alnus* sp.) is also possibly present but not confidently confirmed. Flint and fired clay were recovered from the residue.
- C.1.27 **Trench 97.** Five samples (142, 144, 145, 147 and 151) were taken from the gridded excavation of flints in layer 9705. All of the flots were poor in terms of charred material with most of the volumes being made up of rooting. Sample 142 in particular appears to contain now dried anaerobically preserved wood with possible seeds and wood fragments present in several other samples. A subsample for this context was taken from sample 142 for processing and assessment of the anaerobically preserved material and is reported separately. Flint was recovered from sample 142 but no artefacts were recovered from the others.
- C.1.28 **Trench 99.** Two samples (140 and 143) were taken from layer 9901. The flots are heavily dominated by modern roots and moderate quantities of charcoal. No artefacts were recovered from the residues of either sample.
- C.1.29 Subsoil layer 9902 was also sampled (146) producing a flot mostly comprising modern roots and no artefacts were recovered.
- C.1.30 **Trench 101.** Sample 23 from fill 10104 of pit 10103 produced a poor flot consisting of charcoal, some of which is of ring-porous type, and a couple of wheat grains. Bone was recovered from the residue.
- C.1.31 **Trench 102.** Sample 15 from fill 10215 of pit 10214 produced a charcoal-dominated flot. Preliminary identification of some of the charcoal seems to suggest the assemblage is dominated by lime (cf *Tilia* sp.) but further analysis and verification would be needed to confirm this. The charcoal is friable, which supports the observations made under the microscope but also hinders identification. Burnt flint was recovered from the residue and undiagnostic fired clay was noted as present in the finer fractions.
- C.1.32 Sample 16 from fill 10217 of pit 10216 produced a charcoal-dominated flot. As with sample 15 initial assessment of the charcoal suggests an almost purely lime assemblage, subject to further analysis and verification. Also mirroring sample 15, burnt flint was recovered from the residue and fired clay was noted for the finer fractions.
- C.1.33 **Trench 103.** Three samples (95, 122 and 137) were taken from the gridded excavation of flints in layer 10312. All flots are poor, mainly consisting of modern roots, and no artefacts were recovered from the residue.
- C.1.34 **Trench 104.** Three samples (35, 46 and 59) were taken from gridded excavation of flints in layer 10402. The flots were poor, consisting mostly of modern roots and fine sediment. No artefacts were recovered from the residues.

- C.1.35 Sample 120 from fill 10404 of ditch 10403 produced a large charcoal-rich flot. The charcoal appears to consist of both ring-porous and diffuse-porous types, but actual identification is likely to be hindered by preservation. Oak was identified but several other fragments were highly vitrified obscuring internal structures, and exterior encrusting also extended to the internal structure. Large quantities of burnt flint were recovered from the residue along with a little fired clay.
- C.1.36 Two samples (127 and 128) were taken as part of the gridded excavation of flints in fill 10408 of cut 10407 (a possible gully). Both flots are small and the charred material is mostly charcoal. A significant portion of the charcoal in 127 is <2mm on one plane so the diagnostic fragment count is smaller than Table 16 indicates. No artefacts were recovered from the residue of either sample.
- C.1.37 **Trench 105.** Three samples (119, 138 and 141) were taken from the gridded excavation of flints in layer 10503. The flots were generally poor with most of the measured volumes consisting of modern roots and fine sediment. Apart from a small quantity of flint recovered from sample 141 the residues produced no artefacts.
- C.1.38 **Trench 107.** Sample 40 from fill 10702 of pit 10700 produced a poor flot of <2mm unquantified charcoal flecks and some burnt flint was extracted from the residue.
- C.1.39 Sample 91 from buried soil 10710 produced a poor flot and no artefacts were recovered from the residue.
- C.1.40 Sample 92 from buried soil 10711 produced a poor flot and no artefacts were recovered from the residue.
- C.1.41 Sample 93 from layer 10708 produced a poor flot and no artefacts were recovered from the residue.
- C.1.42 Sample 133 from fill 10724 of posthole 10723 produced a flot with no charred material. The recovered material appears to be preserved wood fragments that were dried anaerobically. Similar material was also extracted from the residue.
- C.1.43 Sample 134 is from fill 10722 of posthole 10724, and also contains wood fragments along with occasional charcoal fragments. No artefacts were recovered from the residue.
- C.1.44 Sample 135 from fill 10726 of pit 10725 produced a charcoal-rich flot. The charcoal is a mix of ring-porous and diffuse-porous types with both elm and possible hazel being identified. No artefacts were recovered from the residue.
- C.1.45 Sample 136 from fill 10727 of pit 10725 produced a poor flot with a single charred dock seed (*Rumex* sp.). No artefacts were recovered from the residue.
- C.1.46 **Trench 109.** Sample 139 from fill 10908 of pit 10907 produced a poor flot. A single charred wheat grain is present along with some indeterminate chaff fragments. No artefacts were recovered from the residue.
- C.1.47 **Trench 113.** Five samples (54 -58) were taken through a sequence of colluvial layers (11301, 11302 and 11304) and buried soil layers (11303) down to the natural (11305) in this trench. All of the flots are poor, usually consisting of undiagnostic charcoal flecks. A single possible indeterminate grain was recovered from layer 11304, sample 57 and a possible grain fragment may be present in buried soil layer 11303, sample 56. Burnt flint was recovered from sample 56 and the rest of the residues produced no artefacts.

- C.1.48 **Trench 127.** Sample 132 from fill 12707 of pit 12706 produced a large charcoal-rich flot. Several of the fragments measure up to 30mm in at least one axis and the assemblage appears to consist mainly of diffuse-porous types. Assessment identified hazel and apple/hawthorn (Maloideae). Burnt flint was extracted from the residue.
- C.1.49 **Trench 138.** Sample 180 from fill 13807 of pit 13806 produced a small flot with a modest quantity of charcoal. No artefacts were recovered from the residue.
- C.1.50 Sample 190 from fill 13809 of pit 13808 produced a modest flot. Apart from charcoal an indeterminate grain fragment is also present. Flint was recovered from the residue.
- C.1.51 **Trench 139.** Sample 187 from fill 13905 of pit 13904 produced a poor flot and a little flint was recovered from the residue. Fired clay is noted as being present but was not recovered.
- C.1.52 Two samples (188 and 189) were taken from fills (13912 and 13913) of tree-throw hole 13911. Both flots were poor, consisting mainly of modern roots and both residues produced flint.
- C.1.53 **Trench 140.** Sample 152 is from context 14010 which is described as a layer but may be the same as fill 14004. The flot is poor, with most of the charcoal being hand-collected from the residue, which produced no artefacts.
- C.1.54 **Trench 141.** Sample 148 from layer 14106 produced a poor flot of modern roots and the residue produced a small amount of fired clay.
- C.1.55 **Trench 151.** Sample 194 from fill 15107 of pit 15106 produced a small flot, whose volume is bulked out by a large quantity of modern roots. The charred grain is a mix of wheat and oat, and several glume base fragments were also identified. Flint and pottery were recovered from the residue.
- C.1.56 Sample 196 from fill 15112 of ditch 15108 produced a small flot with most of the recorded volume being roots. A singular charred wheat grain was identified along with some glume base fragments. Pottery and flint were recovered from the residue.
- C.1.57 **Trench 152.** Sample 179 from fill 15210 of pit 15209 produced a poor flot and the residue produced no artefacts.
- C.1.58 **Trench 161.** Sample 193 from fill 16104 of pit 16103 produced a small charcoal-common flot with pottery recovered from the residue.
- C.1.59 **Trench 164.** Sample 177 from fill 16412 of pit 16410 produced a modest flot. Charcoal is the dominant component, and the identified grain is wheat. No artefacts were recovered from the residue.
- C.1.60 **Trench 174.** Sample 153 from fill 17405 of pit 17404 produced a modest flot. Charcoal appears mostly of ring-porous type with oak being identified. No artefacts were recovered from the residue.
- C.1.61 **Trench 175.** Sample 178 from fill 17510 of ditch 17509 produced a poor, modern root-filled flot and no artefacts were recovered from the residue.
- C.1.62 Colluvial layers 17505 and 17506 were sampled (191 and 192 respectively). Both flots were poor with charred material consisting of undiagnostic charred flecks. The recorded charcoal in 191 was hand-recovered from the residue with flint also being recovered from the residues of both samples.

- C.1.63 **Trench 176.** Sample 129 from fill 17606 of pit 17604 produced a poor flot containing undiagnostic charcoal flecks. Burnt flint and fired clay were recovered from the residue.
- C.1.64 Sample 130 from fill 17609 of pit 17607 produced a large charcoal-rich flot. The charcoal appears to be predominantly of ring-porous type with oak identified and hazel also present. No artefacts were recovered from the residue.
- C.1.65 Samples 181 – 186 were taken during excavation of human remains recorded as Sk.17622. Details of these samples are recorded in Table 17.
- C.1.66 **Trench 178.** Two samples (131 and 155) were taken from pit 17807. Sample 131 from fill 17808 produced a modest flot. Identified grain is wheat and the presence of several weed seeds was recorded. Damage to the surface textures of the weed seeds means that identifications were not undertaken at this stage. Pottery was recovered from the residue. Sample 155 from fill 17809 produced a poor flot and no artefacts were recovered from the residue.
- C.1.67 **Trench 191.** Sample 195 from fill 19113 of ditch 19111 produced a generally poor flot with most of the volume consisting of modern roots. Wheat is present and pottery was recovered from the residue.
- C.1.68 **Trench 234.** Sample 74 from fill 23416 of pit 23414 produced a poor flot consisting of modern roots and undiagnostic charcoal fragments. No artefacts were recovered from the residue.
- C.1.69 **Trench 235.** Sample 75 from fill 23507 of ditch 23506 produced a poor flot mainly consisting of modern roots. Pottery was recovered from the residue.
- C.1.70 **Trench 237.** Sample 64 from fill 23704 produced a poor flot and no artefacts were recovered from the residue.
- C.1.71 **Trench 238.** Sample 41 from fill 23807 of ditch 23806 produced a poor flot. Wheat was identified and pottery was recovered from the residue.
- C.1.72 **Trench 239.** Sample 39 from fill 23904 of pit 23903 produced a small flot with most of the volume consisting of modern roots. The charred grain is damaged but likely to be wheat and one or two specimens of charred dock and goosefoot seeds (*Chenopodium* sp.) were also identified. Pottery and a small fragment of animal bone were recovered from the residue and the presence of small undiagnostic fired clay fragments was also noted.
- C.1.73 **Trench 240.** Sample 43 from fill 24006 of ditch 24005 produced a poor flot with the only charred material of note being an indeterminate grain fragment and a few charcoal fragments. Pottery was recovered from the residue and the presence of small undiagnostic fired clay fragments was noted.
- C.1.74 **Trench 242.** Sample 38 from fill 24206 of ditch 24205 produced a poor flot with the only recordable charred material consisting of some charcoal fragments. Pottery and bone were recovered from the residue.
- C.1.75 **Trench 243.** Sample 72 from fill 24304 of ditch 24303 produced a poor flot and no artefacts were recovered from the residue.

## Discussion

- C.1.76 Recovery of charred plant remains from samples taken from across the excavated area was generally poor with either limited material or poor preservation, but this was not true of all samples. A large proportion of the flots contain either few or no charred material, but since charred plant remains are well-preserved in a small number of samples, where they are absent or scarce it is unlikely to be purely as a result of post-depositional conditions. It is likely that activities which would lead to significant charred assemblages were occurring only in small selected areas. Several of the samples were collected from grids excavated for flints and these were, not unexpectedly, usually unproductive in terms of charred plant remains.
- C.1.77 The most productive features in terms of plant remains were a set of medieval pits in Trench 94 where wheat was recovered in good quantity with also some evidence for oat and barley. Small legumes were also present in these three features along with several common crop contaminants.
- C.1.78 Outside Trench 94, cereal recovery was often limited to small numbers of wheat grains or indeterminate grain fragments and other charred plant remains were similarly sparse.

## Charcoal

- C.1.79 Charcoal is present to some degree in most of the samples across the site. Preservation appears to be variable with some samples having heavily encrusted charcoal, with exterior staining extending to the internal structure. Material from sample 120 also showed a much higher level of vitrification in comparison to other samples where identification was undertaken. Barring sample 120, charcoal identification was not significantly hindered by preservation and the difficulties experienced in charcoal identification from samples 15 and 16 (Trench 102) are attributed to taxon-specific preservation factors, as discussed below.
- C.1.80 Species diversity is variable between samples and there is taxonomic diversity within some samples as well. Initial assessment seems to suggest that some features are either heavily dominated by a single wood type or exclusively contain a single taxon but given the small number of fragments assessed per sample further analysis would be needed to confirm.
- C.1.81 The presence of elm (Samples 42 and 135) could be potentially of interest if prehistoric, relating to the topic of elm declines. Unfortunately, there is currently no dating for the relevant features so the significance of the elm charcoal cannot be fully determined at this stage.
- C.1.82 Two features that appear to contain only lime (Samples 15 and 16) are significant because lime charcoal is usually soft and friable and rarely survives archaeologically; this also causes difficulty in identification as clean planes are hard to achieve. At this stage the identification of lime is provisional and will need further verification to confirm.
- C.1.83 The presence of elm and possibly lime in this taxonomically diverse assemblage indicates that even without considering anaerobically preserved material and pollen the area could provide samples with potential to contribute to the topic of Holocene woodland change.

C.1.84 Two samples were taken specifically with the aim of providing material suitable for radiocarbon dating. These were sample 121, which includes about 5-10 fragments of potentially identifiable charcoal and sample 151, which includes identifiable charcoal but the only taxon identified at the present time is oak. If radiocarbon dating is required, further identification work would be needed to identify short-lived material if present.

### Recommendations for retention/disposal

C.1.85 The flots warrant retention until all works on site are complete. Further work on the flots would not be expected at this stage unless material is required for radiocarbon dating. The material, particularly the charcoal has potential to be of scientific interest and would be viable for further work as part of the future analysis of the site. Flots with potential for further work and those of scientific interest should be retained in the archive whilst flots with no material can be discarded as part of the final deposition process.

Sample no.	Context no.	Feature/Deposit	Trench	Date	Sample vol. (L)	Flot vol. (ml)	Charcoal >2mm	Grain	Chaff	Weeds	Other Charred	Molluscs
4	9204	9204	92	Med	16	25	+					
11	1704	1703	17	LBA-EIA/ERB	31	20	+++					
12	804	803	8	Sax	8	10	++			+		
13	904	903	9		6	25	+	+		+		
15	1021 5	10214	102		36	125	++++					
16	1021 7	10216	102		34	125	++++					
18	9407	9404	94	RB or Med	24	50	+++	+++		+	+	
21	4206	4205	42		18	55	+++					
23	1010 4	10103	101	EMed	35	12	++	+				
27	9008	9008	90		8	5	++					
28	9421	9415	94	Med	30	100	+++	+++	+	++	++	+
29	9422	9415	94	RB or Med	27	30	++	++			+	
35	1040 2	10402	104		32	12	+					+
38	2420 6	24205	242	ERB	33	25	++					
39	2390 4	23903	239	IA?	32	50	++	+		+		
40	1070 2	10700	107		5	5						
41	2380 7	23806	238	ERB	33	20	++	+				+
42	9607	9606	96		29	150	++++					
43	2400 6	24005	240	ERB	33	25	+	+				
46	1040 2	10402	104		32	25	++					+
54	1130 1	11301	113		5	5						

Sample no.	Context no.	Feature/Deposit	Trench	Date	Sample vol. (L)	Flot vol. (ml)	Charcoal >2mm	Grain	Chaff	Weeds	Other Charred	Molluscs
55	1130 2	11302	113		6	5						
56	1130 3	11303	113	MBA-MIA	29	25	+					
57	1130 4	11304	113		5	3	+	+				
58	1130 5	11305	113		5	4	+					
59	1040 2	10402	104		33	50	+					+
64	2370 4	23703	237	MIA	19	16	+					
72	2430 4	24303	243		9	25	+					
73	4904	4903	49	LBA	12	25	+++	+				
74	2341 6	23414	234		36	25						
75	2350 7	23506	235	LBA-MIA/RB	26	25	+					
76	4005	4004	40		20	25	+++	+				+
85	2604	2604	26		33	8	++					
86	2614	2614	26		22	25	++			+		
87	6704	6703	67	ENeo or BA-MIA	5	10	++					+
91	1071 0	10710	107		10	14	+			+		
92	1071 1	10711	107		8	5	+			+		
93	1070 8	10708	107	ERB	13	10	++					+
95	1031 2	10312	103		32	14	+					++
102	326	326	3	EPMed	29	25	+++	++				
118	9505	9505	95		14	14	+					
119	1050 3	10503	105		32	50	++					
120	1040 4	10403	104		32	100	++++					
121	3305	3305	33		31	10	++					
122	1031 2	10312	103		32	10	+					++
127	1040 8	10407	104		24	25	+++					+
128	1040 8	10407	104		8	14	++					
129	1760 6	17604	176		15	10						
130	1760 9	17607	176		21	250	++++					
131	1780 8	17807	178	IA	30	50	+++	++	+	+		

Sample no.	Context no.	Feature/Deposit	Trench	Date	Sample vol. (L)	Flot vol. (ml)	Charcoal >2mm	Grain	Chaff	Weeds	Other Charred	Molluscs
132	1270 7	12706	127		21	200	++++			+		+
133	1072 4	10723	107		8	375						
134	1072 2	10723	107		26	18	+					
135	1072 6	10725	107		9	90	++++					
136	1072 7	10725	107		16	5	++			+		
137	1031 2	10312	103		32	25						++
138	1050 3	10503	105		32	50	++					
139	1090 8	10907	109		18	14	++	+	+			
140	9901	9901	99	MBA-MIA	36	60	++					
141	1050 3	10503	105		29	20	++					
142	9705	9705	97		17	150	+					+
143	9901	9901	99	MBA-MIA		50	+++					
144	9705	9705	97		32	75	++					
145	9705	9705	97		27	50	+					
146	9902	9902	99		28	25	++					
147	9705	9705	97		32	50	+			+		
148	1410 6	14106	141		3	12	+					
151	9705	9705	97		32	30						
152	1401 0	14010	140		8	2	++					
153	1740 5	17404	174		5	50	+++					
155	1780 9	17807	178	IA	6	14	++					
177	1641 2	16410	164		16	50	+++	+				+
178	1751 0	17509	175	Pre	16	10	+					
179	1521 0	15209	152		16	25	+				+	
180	1380 7	13806	138		5	14	+++					+
187	1390 5	13904	139		18	30	+					
188	1391 2	13911	139		14	5	+					
189	1391 3	13911	139		18	5						
190	1380 9	13808	138		40	50	+++	+				++



Sample no.	Context no.	Feature/Deposit	Trench	Date	Sample vol. (L)	Flot vol. (ml)	Charcoal >2mm	Grain	Chaff	Weeds	Other Charred	Molluscs
191	1750 5	17505	175		6	1	+					
192	1750 6	17506	175		5	5						
193	1610 4	16103	161	MBA-MIA	32	18	+++					+
194	1510 7	15106	151	MIA?	32	50	+	++	+	+		
195	1911 3	19111	191	RB	32	50	++	+				+
196	1511 2	15108	151	MIA?	32	25	+	+	+			
197	4806	4805	48		8	5	+					
198	7908	7909	79		16	25	++					+
199	7907	7909	79		16	50	+					

Table 16: Assessment of bulk samples

Key: +=present (up to 5 items), +=frequent (5-25), +++=common (25-100), ++++=abundant

Sample no.	Context no.	Cut	Volume (L)	Element	Notes
181	17621	17615	45	Grave fill	Brown sandy clay loam
182	17621	17615	9	Skull	Brown sandy clay loam
183	17621	17615	4	Chest	Brown sandy clay loam
184	17621	17615	7	Pelvis	Brown sandy clay loam
185	17621	17615	6	Feet	Brown sandy clay loam
186	17621	17615	11	Grave base	Brown sandy clay loam

Table 17: Summary of skeletal samples

Sample no	Context no	15	16	42	130	132	135	153
		10215	10217	9607	17609	12707	10726	17405
Taxon	Common name							
Maloideae	Apple/Hawthorn					9		
<i>Ulmus</i> sp.	Elm			1			4	
<i>Quercus</i> sp.	Oak			3	8		1	10
<i>Alnus</i> sp.	Alder			2(cf)				
<i>Corylus avellana</i>	Hazel			2(cf)	1	1	3(cf)	
<i>Tilia</i> sp.	Lime	10(cf)	10(cf)					
	Indet/Unid			2	1		2	

Table 18: Summary of charcoal identifications

## C.2 Waterlogged Plant Remains

By Sharon Cook

### Introduction

C.2.1 A total of seventeen samples, mostly of 10 or 20 litres, were taken from peaty deposits encountered within the evaluation to assess the extent of anaerobic preservation. In particular, the aim of this assessment is to characterise the condition and abundance of waterlogged plant remains (WPR), insects and molluscs. The samples came from a series of alluvial and peaty layers within Trenches 25, 91, 92, 162 and 170.

### Method

C.2.2 One litre of each sample was processed using the wash over method. The flots and residues were collected in 250µm meshes and kept wet to facilitate preservation. The flot material was scanned using a low power (x10-x40) binocular microscope to identify any plant and other quantifiable remains, while a subsample of each residue was scanned to identify the potential for mineralisation. Any additional sediment was retained pending the result of this assessment.

C.2.3 Identification of wild plant remains is with reference to the Digital Seed Atlas of the Netherlands (Cappers *et al.* 2012) and by comparison with modern reference material. Classification and nomenclature of plant material follows Stace (2010).

### Results

C.2.4 A summary of the samples is presented in Table 19 and the result of the assessment in Table 20.

C.2.5 The flots produced from samples taken from sequential deposits within Trenches 162 and 170 are small with no plant remains that could be categorically identified as anaerobically preserved (waterlogged). The volumes comprise mainly fine roots with a modern appearance together with small woody fragments which are likely to be fragments from larger roots. The samples from Trenches 25, 91 and 92, by contrast, appeared to be more organic and the flots produced were larger. After inspection, however, plant remains proved to be infrequent. Flecks of charred plant material, particularly charcoal are present within several flots but are <2mm and not suitable for further identification. The only seeds are occasional goosefoots (*Chenopodium* sp.) with a modern appearance. The few snails in the flots are of very small size, <2mm.

C.2.6 **Trench 25.** Samples 103, 104 and 105 from layers 2505 and 2506 produced flots containing small soft and degraded woody fragments in a peaty matrix together with occasional small charcoal fragments. Occasional seeds from rushes (*Juncus* sp.) are present in samples 104 and 105.

C.2.7 **Trench 91.** Samples 5, 6 and 10 from buried soil 9119 and layers 9109 and 9108 respectively contain very little except for occasional fine roots and fragments of very degraded wood in what were well-humified peaty deposits.

C.2.8 **Trench 92.** Sample 3 from dark organic silty clay deposit 9205 produced a flot which is very similar to those from Trench 91 samples.

C.2.9 **Trench 97.** Sample 142 from Trench 97 was a brown silty loam deposit but the flot is similar in appearance to those from Trench 25 and includes rare seeds from sedges

(*Carex* sp.). The sample was taken from what was thought to be a flint scatter and additional sediment was also processed for flint retrieval and to assess and charred plant macrofossils (Palmer, *Infra*).

- C.2.10 **Trench 162.** Samples 164, 165, 166, 167, 168, 169 and 170 came from sequential layers in Trench 162 which include colluvium (slopewash), Pleistocene deposits and, at the base of the section, a possible redeposited fluvial sand deposit. After processing all produced small or tiny flots containing almost no plant remains and no evidence of waterlogging.
- C.2.11 **Trench 170.** Samples 173 and 174 came from alluvial deposit 17002 and primary ditch fill 17007 respectively. While larger in volume than those from Trench 162, the flots were also poor in plant remains. The presence of water flea (*Daphnia* sp.) ephippia within the flot of sample 174 shows that this feature had held water previously.

### Discussion and conclusions

- C.2.12 The samples have proved to be poor in identifiable waterlogged plant material. The organic silty clays within Trenches 91 and 92 are well humified but show at least semi-permanent waterlogging of this area, however the poor condition of the woody fragments and the lack of seeds or other environmental indicators means that no further interpretation is possible. This is also the case with the samples from Trenches 25 and 97, where the only identifiable seeds are those of rushes and sedges confirming the wet/damp conditions. There is little evidence of waterlogged preservation of plant material in the samples from Trenches 162 and 170, although water flea ephippia demonstrate that the ditch in Trench 170 held water.
- C.2.13 Where charcoal fragments are present, their small size together with the presence of *Cecilioides acicula* and fine roots suggests that they have potentially been moved through the soil by bioturbation. The goosefoot seeds are in extremely good condition and appear to be modern.
- C.2.14 The presence of water flea (*Daphnia* sp.) ephippia within the flot of sample 174 shows that this area has been under water previously. Ephippia are dormant eggs produced to cope with unfavourable conditions by waiting to develop and hatch when conditions become more favourable (Pietrzak & Slusarczyk 2006). They are likely to indicate fluctuations in the aquatic environment such as periodic drying and as such on this site are likely to indicate seasonal flooding, with the ephippia ‘resting’ over the dry period to resume development later.

### Recommendations

- C.2.15 The samples have proved to be poor in identifiable plant remains and insects. No further analysis of the samples is proposed and the material may be disposed of prior to archive deposition of the project.

Sample	Context	Depth	Feature Type	Soil Description
3	9205	0.80	Layer	Dark greyish brown silty clay
5	9119	1.00	Buried soil	Dark greyish brown silty clay
6	9109	1.20	Layer	Dark greyish brown silty clay
10	9108		Layer	Dark greyish brown silty clay
103	2505	1.20	Layer	5YR 4/2 dark reddish grey clay loam
104	2506	1.35	Layer	5YR 5/3 reddish brown silt loam
105	2506		Layer	5YR 3/3 dark reddish brown silt loam
142	9705		Layer	10YR 6/3 pale brown silt loam

164	16203	0.70	Layer	10YR 5/4 yellowish brown sandy clay loam
165	16207		Layer	7.5YR 6/4 light brown sandy clay
166	16208		Layer	10YR 5/6 yellowish brown silty clay
167	16209		Layer	10YR 5/6 yellowish brown sandy clay
168	16210		Layer	7.5YR 4/6 strong brown sandy clay loam
169	16204		Layer	10YR 5/8 yellowish brown clay
170	16202	0.50	Layer	10YR 6/6 brownish yellow sandy clay
173	17002	0.48	Layer	10YR 5/2 greyish brown clay with orange staining
174	17007	0.80	Ditch fill	10YR 5/4 yellowish brown clay loam

Table 19. Details of the contexts sampled for waterlogged remains

Sample No	Context No	Sample Vol (L)	Flot Vol (ml)	Wood	Insect	Fruit/Nut	Seeds	Mineralised	Charred	Molluscs	Other	Notes
3	9205	1	50	+++								Fine roots and small woody frags. Peaty appearance.
5	9119	1	10	+								Small flot. Occasional fine roots and small degraded woody frags.
6	9109	1	10	++					++			Small flot. Occasional fine roots and degraded woody frags Occasional charcoal c 2mm.
10	9108	1	20	+								Occasional fine roots and small degraded woody frags
103	2505	1	2	++					++			Tiny flot. Occasional fine roots and degraded woody frags Occasional charcoal <2mm.
104	2506	1	18	+++	+		++		++			Occasional fine charcoal and abundant degraded small woody fragments. Occasional <i>Juncus</i> seeds. Rare insect frags. Peaty.
105	2506	1	30	++++	++		++		++			Occasional fine charcoal mainly <2mm and abundant small woody frags. Occasional <i>Juncus</i> seeds. Rare insect frags. Peaty.
142	9705	1	38	++++	+		+		++			Occasional fine roots and abundant degraded wood. Occasional charcoal <2mm. Occasional <i>Carex</i> sp. seeds. Rare

Sample No	Context No	Sample Vol (L)	Flot Vol (ml)	Wood	Insect	Fruit/Nut	Seeds	Mineralised	Charred	Molluscs	Other	Notes
												insect fragments. Peaty.
164	16203	1	1	+			+		?	+		Tiny flot. Occasional fine roots and small degraded wood, ?root. Molluscs all <2mm. <i>Ceciliodes</i> also present. Rare <i>Chenopodium</i> sp. Small flecks of ?charred material.
165	16207	1	1	+					?			Tiny flot. Occasional fine roots and small degraded wood frags. Small flecks ?charred material.
166	16208	1	<1									Tiny flot. Occasional fine roots.
167	16209	1	<1									Tiny flot. Occasional fine roots.
168	16210	1	<1									Tiny flot. Occasional fine and woody root frags.
169	16204	1	<1									Tiny flot. Occasional fine and woody root frags.
170	16202	1	<1							+		Tiny flot. Occasional fine roots. Rare molluscs.
173	17002	1	1				+		++			Small flot. Occasional fine and woody root frags. Charcoal <2mm. Single <i>Chenopodium</i> sp.
174	17007	1	5	+			++		+	++	++	Flot is mainly fine roots and small degraded woody frags (<2mm) probably root. Rare <i>Chenopodium</i> sp. Occasional molluscs all <2mm. <i>Daphnia</i> ephippia. Occasional charcoal <2mm.

Table 20. Assessed remains within the waterlogged samples

Key: + 1-4, ++ 5-24, +++ 25-49, ++++ 50-99, +++++ 100+

## C.3 Animal Bone

By Adrienne Powell

### Introduction

- C.3.1 A total of 434 animal bone fragments, weighing 4.731kg, was recovered by hand excavation from 29 contexts. Residues from three environmental samples produced a further 7 fragments (7g), none of which were identifiable.
- C.3.2 The material has been recorded on a 'by context' basis: for each context, or bag, the number of fragments identifiable to taxon has been recorded, as well as the number of specimens for each taxon providing ageing, sexing or biometric data. The presence of butchery, burning or pathology was noted and the overall condition of the bone in each context has been graded on a scale of 1 = excellent, to 5 = very poor, just identifiable as 'bone'. Conjoining fragments from recently broken specimens were counted as one.

### Description

- C.3.3 Few contexts produced more than a single identifiable fragment (Table 21) and the overall proportion of identifiable bone is only 9.2%. Most of the bone is, however, in moderate condition with low levels of surface etching and abrasion. Bone from the most productive contexts, 22905 and 23011, whilst having reasonable surface preservation, tends to be powdery and brittle.
- C.3.4 Butchered specimens and burnt bone were present in two contexts each, whereas dog gnawing was noted in four contexts.
- C.3.5 Equid bones were the most frequent in the assemblage due to their prevalence in the two contexts 22905 and 23011, of which 22905 is believed to be post-medieval in date. The equid specimens from 22905 may represent a single individual as they include paired right and left scapulae. Large mammal vertebrae and ribs present may also be equid; one of these vertebrae exhibits the only pathological case noted, showing an area of inflammation on the centrum as well as ossification of the ventral ligament. In contrast, 23011 contained at least three individuals, represented by three left scapulae. The remains included adjoining P<sub>2</sub> and P<sub>3</sub> from one animal and an M<sub>1</sub> or M<sub>2</sub> from a second; the teeth came from elderly animals with the P<sub>2</sub>, in particular, being worn down to the root. One specimen, a cranial fragment of an axis vertebra, showed fine cutmarks suggesting disarticulation.
- C.3.6 A further notable equid specimen from the undated linear feature 22912 was a metacarpal, the size and robustness of which suggests a possible post-Medieval date.
- C.3.7 Other species are present in small numbers only. Sheep/goat bones are the most common but only slightly more so than those of cattle; pig is only represented by a single specimen.
- C.3.8 No ageable jaws were recovered but ageable epiphyses were present in cattle, sheep/goat and equid specimens and cattle and equids also produced a small sample of measurable bones.

C.3.9 This assemblage demonstrates the survival of bone on the site and that any future excavations are likely to recover material suitable for addressing questions of animal husbandry and site economy.

**Recommendations regarding the conservation, discard and retention of material**

C.3.10 The assemblage has not been fully recorded and should be retained until completion of the project and incorporated into subsequent faunal analyses.

Context	Sample	Count	Weight (g)	Cattle	Sheep/goat	Pig	Equid	Total NISP
326		3	22		2	1		3
4810		6	33	1	2			3
4904		4	15					0
4904	73	3	5					0
4905		2	16		1			1
9213		2	6					0
9226		3	6					0
9421		2	1					0
9712		6	61					0
10104	23	1	<1					0
10104		5	2					0
10106		1	<1					0
10108		1	85	1				1
10110		4	55				1	1
14004		8	38					0
15111		1	3					0
16714		5	<1					0
17504		3	24	1				1
17510		10	14					0
17519		1	30	1				1
18010		14	20					0
18417		2	5					0
18519		8	31	1				1
19605		5	2					0
19703		3	73					0
22905		188	2789	2	1		7	10
22912		1	174				1	1
23009		2	11				0	0
23011		125	1107		4		13	17
23507		18	108				1	1
23704		1	<1					0
24206	38	3	2					0
<b>Total</b>		<b>441</b>	<b>4738</b>	<b>7</b>	<b>10</b>	<b>1</b>	<b>23</b>	<b>41</b>

Table 21: Identifiable animal bone assemblage summary

## C.4 Human Remains

By Annsofie Witkin

### Introduction and provenance

- C.4.1 A poorly-preserved skeleton (17622) was recovered from a sub-oval pit (17615) within Trench 176 (Plate 20). The pit was 0.13m deep, 0.82m wide and 1.22m long. The individual was crouched, lying on the right side with the head to the south. Pottery fragments were also recovered above the cranium.
- C.4.2 An attempt was made to obtain a radiocarbon date but not enough collagen survived to produce a successful result.

### Osteological analysis and results

- C.4.3 The analysis was carried out in accordance with the published guidelines set out by Brickley and McKinley (2004) and updated by Mitchell and Brickley (2017).
- C.4.4 The individual was less than 25% complete and highly fragmented. The elements comprised mandibular and maxillary dentition (including 17 teeth), fragments of the humeri, right radius and ulna shaft, right hand, fragmented right femur shaft, tibia and fibula shaft. The condition of the bone surfaces was graded as a four, after McKinley (2004, 16), meaning that they were all affected by post-mortem erosive action, although the general profile had been maintained.
- C.4.5 The sex of the individual could not be determined as no diagnostic indicators survived. Age could only be estimated from the right first molar using dental attrition (Miles 1962). The estimate suggested an adult aged between 24 and 30 years. The age estimation was based on a single tooth. The wear on the molars may not be bilaterally uniform as various pathological lesions such as caries and abscesses may cause one side of the mouth to be favoured during mastication. The age estimate must therefore remain tentative, and it is sufficient to say that this individual was aged over 18 years.
- C.4.6 A number of pathological lesions was present on the dentition. Two small carious lesions were present on two teeth from the anterior dentition. Caries is formed when the enamel is destroyed by acid producing bacteria found in dental plaque (Hillson 1996: 269). Calculus deposits were also recorded on the teeth. The deposits were generally small but a medium sized deposit was also observed on the right lateral maxillary incisor (Brothwell 1981: 155). Calculus comprises mineralised plaque and is commonly situated on the dentition near the salivary ducts (Hillson 1996, 255-256). Lastly, linear enamel hypoplasia was observed on the anterior dentition in the form of a horizontal line. This refers to a period of growth arrest that is multi-causal, including nutritional deficiency and periods of childhood illness (Roberts and Manchester 1995: 58). The period of non-specific stress occurred when the individual was aged between 3 and 4.9 years old (Primeau *et al.* 2015: 386).



## C.5 Shell

By Rebecca Nicholson

### Introduction

- C.5.1 A small quantity of shell in fair-poor condition, was recovered by hand from Trench 101. The shells came from medieval pit fill 10104 (37g) and medieval ditch fill 10106 (30g).
- C.5.2 The shell is all European flat oyster (*Ostrea edulis* L.), with 2 left and one right valve in 10104 and two left valves in 10106. In every case the left valves are too incomplete to measure and, in the case of those from 10104 has internal blisters and flattened heels, the latter indicative of growth on a hard surface. One of the valves from 10106 has an elongated and angled hinge which suggests exposure to strong currents such as might be found in a tidal channel.
- C.5.3 One of the valves from 10106 has a crude subrectangular perforation, measuring 19.5 x 14.3 mm in the middle of the shell. The same shell is stained orange internally, a colour which may derive from the surrounding soil. The cause of the perforation is unclear. Similar holes have been documented on oyster shells from a range of sites and dates and no consistent explanation has been found for them. Without any cut marks, it is not certain that the perforation was either deliberate or occurred before the shell was discarded.
- C.5.4 The oyster shells probably derive from kitchen waste from a nearby settlement, being widely available in the medieval period.

### Recommendations regarding the conservation, discard and retention of material

- C.5.5 The few shells have no further research value and retention in the archive is not considered necessary.

## C.6 Radiocarbon dating

by Rebecca Nicholson

### Introduction

- C.6.1 Twelve samples were dated by Accelerator Mass Spectrometry (AMS) at the Beta Analytic radiocarbon dating laboratory. All were paired subsamples taken from peaty sediment, with dates obtained on both the humic (alkali soluble) and humin (alkali insoluble) fractions, so for the six submitted samples of bulk peat twelve radiocarbon determinations were obtained. The samples of peat came from monolith samples 7, 8, 24 and 116. Contexts and depths (in mm) from the top of the respective monoliths are given in Table 22.
- C.6.2 The aim of dating the organic sediments in monolith samples 7 and 8 was to clarify the chronology of the peat and basal interface deposit in the base of the valley and ascertain how these deposits relate to the flint scatter. The upper part of the peat profile in many trenches appeared disturbed/bioturbated and produced some recent (19th/20th century) finds. However, in Trench 91 there was clear bedding with intercalation of humified peat and humic silt, which it was hypothesised might indicate an earlier date for the lower part of the sequence in this location. The peat overlies humic silt interface layer 9109 which it was thought could be contemporary with the flint scatters in Trench 103 or possibly of later date.
- C.6.3 The aim of dating the sample from monolith 24 (Trench 90) was to obtain a second date on the base of the peat to compare to the equivalent date from Trench 91. Monolith 166, from Trench 95, was subsampled in order to date a brown, more organic looking sediment within the pale leached horizon in the base of the valley.
- C.6.4 In addition to the samples listed above, a sample of human bone (right femur shaft) from SK 17622 was submitted for AMS radiocarbon dating to the Scottish Universities Environmental Research Centre (SUERC). Unfortunately this sample failed to provide collagen of sufficient quantity and quality to produce a date.
- C.6.5 The reported results (Table 22) are conventional radiocarbon ages (Stuiver and Polach 1977) and were corrected for total fractionation effects and calibration was performed using OxCal 4.4.4 and INTCAL20 (Bronk Ramsey 2009 with 2021 update, Reimer *et al.* 2020). They are presented below with the end points rounded outwards to 10 years following the recommendations of the 1977 International Radiocarbon conference. Reported results are accredited to ISO/IEC 17025:2005 Testing Accreditation PJLA #59423 standards and all chemistry was performed in the Beta Analytic laboratory. When counting statistics produce sigmas lower than +/- 30 years, a conservative +/- 30 BP has been cited for the result. The reported  $\delta^{13}\text{C}$  values were measured separately in an IRMS (isotope ratio mass spectrometer) and are not the AMS  $\delta^{13}\text{C}$  which would include fractionation effects from natural, chemistry and AMS induced sources. All are within the acceptable range for the material.
- C.6.6 The reliability of the dates obtained from the peat and organic sediment were tested using a  $\chi^2$  test on the paired samples (see Tables 23-28). Measurements on both fractions proved to be statistically consistent in three cases and a weighted mean value has been calculated for each pair using the R\_combine facility in OxCal prior to calibration.

- C.6.7 The paired results failed the  $\chi^2$  test for three of the paired samples: monolith 7 (9119) at 320-330mm, monolith 8 (9108) at 60-70mm and monolith 116 (9505) 240-250mm, so in these cases the derived mean, although calculated, is not statistically valid and the full range of both fractions should be cited.
- C.6.8 The upper, more silty, part of the peat in Trench 91 (context 9107) dates to the late Bronze Age, 970-820 cal. BC, and the lower part of the peat (context 9108) dates to the early Bronze Age in this location, at 2140-1950 cal. BC. While the sample from middle of the peat (context 9119), which was dark and well humified, failed to produce a statistically consistent mean date, the dates were all early Bronze Age and stratigraphically in sequence with the other two sets. Both alkali soluble and insoluble fractions from the underlying humic silt interface layer 9109 produced Neolithic determinations, spanning 3370-2920 cal. BC. The base of the peat in Trench 90 (monolith 24) dates to 1750-1620 cal. BC, slightly later than the inception of peat formation in Trench 91.
- C.6.9 The % carbon recovered from the darker lens within the pale soil in the base of a valley (monolith 116 (9505) at 240-250mm), contained a very low ( ~ 0.01%) proportion of carbon after combustion of the alkali insoluble (humin) fraction and this means that the resulting radiocarbon determination may reflect very minor amounts of contamination due to natural carbon migration within the sedimentary profile. In dynamic environments the alkali soluble (humic) fraction may migrate due to water movement, and this can also lead to erroneous dating, typically a younger than expected date. The true age for the organic lens at the base of the valley sampled in monolith 166 has therefore not been established but it seems likely to be either early Holocene or late Glacial, or reflect a period of transition, although an earlier date cannot be ruled out.

Lab. Ref.	Sample	Context	Depth from top of monolith	Material	Fraction dated	$\delta^{13}\text{C}$ (‰)	Radiocarbon Age (BP)	Calibrated date BC (at 95.4%)
Beta - 614819	7	9107	130-140mm	Peat	Alkali soluble	-29.7	2750 +/- 30	990-810 (95.4%)
Beta - 614820	7	9107	130-140mm	Peat	Alkali insoluble	-27.0	2740 +/- 30	980-950 (2.6%) 940-810 (92.8%)
Beta - 614815	7	9119	320-330mm	Peat	Alkali soluble	-28.6	3400 +/- 30	1870-1850 (2%) 1770-1610 (93.4%)
Beta - 614816	7	9119	320-330mm	Peat	Alkali insoluble	-27.3	3660 +/- 30	2140-1940 (95.4%)
Beta - 614811	8	9108	60-70mm	Peat	Alkali soluble	-29.1	3700 +/- 30	2200 - 2160 (9.6%) 2150 - 2010 (82.4%) 2000 - 1970 (3.4%)
Beta - 614812	8	9108	60-70mm	Peat	Alkali insoluble	-27.6	3630 +/- 30	2050 - 1890 (84.5%) 2130 - 2080 (10.9%)
Beta - 614817	8	9109	280-290mm	Peat	Alkali soluble	-29.1	4420 +/- 30	3330-3230 (14.9%) 3180-3160 (1.8%) 3110-2920 (78.7%)
Beta-614818	8	9109	280-290mm	Peat	Alkali insoluble	-27.0	4540 +/- 30	3370-3260 (33.9%) 3250-3100 (61.5%)
Beta - 614821	24	9004	100-110mm	Peat	Alkali soluble	-29.8	3370 +/- 30	1750-1540 (95.4%)
Beta - 614822	24	9004	100-110mm	Peat	Alkali insoluble	-27.7	3420 +/- 30	1880-1840 (8%) 1820-1800 (1.5%) 1780-1620 (86.0%)
Beta - 614813	116	9505	240-250mm	Organic sediment	Alkali soluble	-27.6	8870 +/- 30	8230 - 7940 (90.4%) 7900 - 7840 (5%)
Beta - 614814	116	9505	240-250mm	Organic sediment	Alkali insoluble	-24.7	10290 +/- 30	10500 - 10440 (7.1%) 10430 - 10400 (0.9%) 10380 - 10350 (1.5%) 10310 - 10280 (1.2%) 10230 - 9920 (83.6%) 9910 - 9880 (1.1%)

Table 22: Radiocarbon sample details and calculated age ranges

Sample id, context and depth location	Fraction dated	From (cal BC)	To (cal BC)	%	From (cal BC)	To (cal BC)	%
LTC7L21 7 (9107) 130-140mm	alkali soluble	920	834	68.3	981	817	95.4
LTC7L21 7 (9107) 130-140mm	alkali insoluble	907	833	68.3	971	813	95.4
R_Combine (2745±22 BP)		910	830	68.3	970	820	95.4

Table 23: Results of paired  $\chi^2$  tests on peat samples from monolith 7 at 130-140mm (end points of the combined calibrated date are rounded out by 10 years)

Sample id, context and depth location	Fraction dated	From (cal BC)	To (cal BC)	%	From (cal BC)	To (cal BC)	%
LTC7L21 7 (9119) 320-330mm	alkali soluble	1739	1631	68.3	1866	1615	95.4
LTC7L21 7 (9119) 320-330mm	alkali insoluble	2131	1973	68.3	2137	1948	95.4
R_Combine (3533±22BP)		1920	1770	68.3	1950	1770	95.4

X-Test fails at 5% - X2-Test: df=1 T=37.539(5% 3.8)

Table 24: Results of paired  $\chi^2$  tests on peat samples from monolith 7 at 320-330mm (end points of the combined calibrated date are rounded out by 10 years)

Sample id, context and depth location	Fraction dated	From (cal BC)	To (cal BC)	%	From (cal BC)	To (cal BC)	%
LTC7L21 8 (9108) 60-70mm	alkali soluble	2138	2036	68.3	2199	1980	95.4
LTC7L21 8 (9108) 60-70mm	alkali insoluble	2032	1946	68.3	2130	1896	95.4
R_Combine (3665±22BP)		2130	1970	68.3	2140	1950	95.4

Table 25: Results of paired  $\chi^2$  tests on peat samples from monolith 8 at 60-70mm (end points of the combined calibrated date are rounded out by 10 years)

Sample id, context and depth location	Fraction dated	From (cal BC)	To (cal BC)	%	From (cal BC)	To (cal BC)	%
LTC7L21 8 (9109) 280-290mm	alkali soluble	3099	2935	68.3	3322	2921	95.4
LTC7L21 8 (9109) 280-290mm	alkali insoluble	3362	3111	68.3	3368	3102	95.4
R_Combine (4481 ±22BP)		3330	3100	68.3	3340	3030	95.4

X-Test fails at 5% - X2-Test: df=1 T=7.999(5% 3.8)

Table 26: Results of paired  $\chi^2$  tests on peat samples from monolith 8 at 280-290mm (end points of the combined calibrated date are rounded out by 10 years)

Sample id, context and depth location	Fraction dated	From (cal BC)	To (cal BC)	%	From (cal BC)	To (cal BC)	%
LTC7L21 24 (9004) 100-110mm	alkali soluble	1733	1617	68.3	1743	1542	95.4
LTC7L21 24 (9004) 100-110mm	alkali insoluble	1751	1636	68.3	1873	1622	95.4
R Combine (3395 ±22BP)	1736	1740	1630	68.3	1750	1620	95.4

Table 27: Results of paired  $\chi^2$  tests on peat samples from monolith 24 at 100-110mm (end points of the combined calibrated date are rounded out by 10 years)

Sample id, context and depth location	Fraction dated	From (cal BC)	To (cal BC)	%	From (cal BC)	To (cal BC)	%
LTC7L21 116 (9505) 240-250mm	alkali soluble	8192	7953	68.3	8221	7844	95.4
LTC7L21 116 (9505) 240-250mm	alkali insoluble	10468	9989	68.3	10492	9884	95.4
R Combine (9674±22BP)		9240	9150	68.3	9250	8920	95.4

X-Test fails at 5% - X2-Test: df=1 T=1105.820(5% 3.8)

Table 28: Results of paired  $\chi^2$  tests on peat samples from monolith 116 at 240-250mm (end points of the combined calibrated date are rounded out by 10 years)

## C.7 Geoarchaeology

By Elizabeth Stafford

### Introduction

- C.7.1 The geoarchaeological component of the evaluation comprised the targeted recording and sampling of the deep sedimentary sequences exposed in the trenches to supplement standard archaeological recording. One of the principal objectives of the evaluation trenching was to investigate the archaeological potential of the Holocene colluvial/alluvial sequences contained within valley locations, to identify whether features and/or artefact scatters are preserved within or beneath the sedimentary stack and if any *in situ* buried soils/land surfaces can be detected. The evaluation also intended to provide preliminary information on the nature, depth, and distribution of the Holocene facies in advance of a second phase of purposive test-pitting intended to evaluate the potential of the underlying Pleistocene/Palaeolithic sedimentary sequences.
- C.7.2 The area under investigation has been previously reviewed as part of the scheme-wide Palaeolithic and Quaternary Deposit Model (PQDM) (Wenban-Smith and Bates 2020). It falls partially within the very southern part of zone PQ-14 (Southfields, Land Parcel 6) and the eastern part of PQ-15 (Brook Farm Channel, Land Parcels 6, 7a-c and 8). Zone PQ-14, considered to be of low to moderate Palaeolithic potential, is largely characterised by the presence of fluvial Terrace Gravels of unknown age capping the higher ground, beyond the current area of investigation. The Brook Farm Channel of Zone PQ-15 is located across the majority of the LPs reported upon in this evaluation. This E-W valley-like landform connects the Mar Dyke Basin in the west with the Thames Channel in the south-east and may have acted as a drainage exit for the Mar Dyke during the Pleistocene. Little extant sub-surface data was available for PQ-15 prior to the current investigation, with the assumption the valley was probably infilled with a mixture of poorly-sorted flint gravel mixed with clay/silt/sand. The Palaeolithic potential was assessed as uncertain.
- C.7.3 The majority of the area across Land Parcels 6, 7a-c and 8 is characterised geologically by Thanet Sand Formation (TSF) bedrock, although the Lambeth Group is mapped by the BGS in the very eastern part of LP6. Topographically, elevations vary considerably. A major E-W aligned valley (Valley A, the Brook Farm Channel) dissects the area, flanked by relatively steep slopes and areas of higher ground beyond. The base of this valley is generally dry and managed by a series of drainage ditches, although the water table is high and tends to hold water during wet periods. A large pond is located in the base of the valley immediately east of Land Parcel 7a. Two smaller N-S aligned dry valleys (Valleys B and C) originate from the higher ground in Land Parcel 6 (PQ-14) connected to Valley A in the south, and a further minor N/S valley is located in Land Parcel 7c (Valley D). The BGS maps Head deposits within all four valleys and a small swathe of alluvium along the basal axis of Valley A (falling within Land Parcel 7a). No Terrace Gravels are mapped within the LPs but are present on the higher ground immediately north of Land Parcel 6.

### Method

- C.7.4 The trenches were initially excavated to a maximum of 1m BGL, or less than that where clear Pleistocene deposits or bedrock were exposed, or where archaeological scatters and features were detected.

- C.7.5 A selection trenches in the valley locations and on the higher ground where Pleistocene Head or brickearth-type deposits dominated were excavated to a maximum of c 2m BGL to investigate the sedimentary sequences. Augering was also carried out in the base of some trenches to ascertain the depth of the sequences to bedrock, and in some cases where poor ground conditions precluded excavation to 2m. The trenches in the base of the valleys, particularly in Land Parcels 7a and 7c frequently became flooded and unstable after heavy rain. In these conditions the base of the excavations were not entered for health and safety reasons and recorded from either ground level or the 1m stepped edge.
- C.7.6 Due to the large number of trenches and programme restrictions, it was not possible to carry out deeper excavations in all trenches, the selection of trenches was intended to cover a representative selection. Where buried soils/peat deposits were identified, the full length of the trench was deepened to examine the surface for archaeological remains, rather than one or more sondages to record only their sedimentary characteristics/geoarchaeological potential.
- C.7.7 The recording of the sediments comprised the detailed geoarchaeological logging of one of more 1-2m wide sections in each of the trenches, the number depending on the complexity of the sequences. Each section was allocated a section number and located relative to the National Grid and Ordnance Datum. The sediment sequences were recorded from ground surface on a geoarchaeological log proforma with each layer allocated a unique context number. Preliminary interpretations of associated depositional processes were also recorded on the logs.
- C.7.8 Sediment recording followed Historic England guidelines (2015) and following (Jones *et al.* 1999) typically included a description of texture, compaction, colour, clast size and abundance, bedding structures and other inclusions (eg. charcoal), post-depositional features (eg. rooting, mottling, mineralisation), and the nature of sediment contacts (eg abrupt, diffuse, irregular).
- C.7.9 Sampling of the sediment sequences was carried out in accordance with Historic England guidelines (2011) and was targeted to allow for representative colluvial and/or alluvial sequences from each valley through 10L bulk samples (mainly to assess for the preservation of waterlogged plant remains (WPR) and molluscs) and monoliths. Priority was given to any artefact rich contexts where larger bulk samples up to 40 litres were also recovered for assessment of charred plant remains (CPR) and recovery of micro-artefacts (see Palmer, Appendix C.1 this report). Along with the monoliths, OSL samples were also taken from these sequences to allow for further analysis and dating should this be required. Where sampling was carried out, the log proforma was accompanied by a measured section drawing on permatrace marking the position of the samples.
- C.7.10 Following the completion of fieldwork, the lithological information from the logs was entered into geological modelling software (Rockworks17) to allow the identification and broad correlation of a series of sediment facies. This enabled the creation of digital transects illustrating the key deep trench profiles across the main valley sequences and the location of corresponding samples and associated archaeological finds/features (Transects 1-14, Table 29, Figs 46-59).



## Results

C.7.11 The total number of trenches subject to ge archaeological recording numbered 123, comprising 186 individual profiles (Table 29). A summary of the profiles includes in the transects is presented in Table 30 and the sampled sequences in Table 31.

LP	No, profiles recorded	No, Trenches recorded	Select ge archaeological transects
6	44	26	Transects 1-6 (Figs 46-51)
7a	43	28	Transects 7-8 (Figs 52-53)
7b	21	16	Transects 9-10 (Figs 54-55)
7c	57	42	Transects 11-14 (Figs 56-59)
8	21	11	
<b>Total</b>	<b>186</b>	<b>123</b>	

Table 29: Summary of ge archaeological profiles

LP	Transect	Trench	Section	Easting	Northing	GL (m OD)	Total depth (m BGL)
6	1	3	303	565818.39	180035.37	16.56	0.79
6	1, 3	3	306	565813.36	180014.34	14.79	0.97
6	1	4	400	565828.88	180073.29	18.68	2.00
6	1	5	502	565834.29	180096.04	19.17	1.92
6	2	7	700	565884.80	180121.45	21.58	0.78
6	2	7	701	565893.20	180134.08	22.23	0.53
6	2	8	800	565876.37	180079.10	21.50	0.47
6	2	9	901	565877.68	180038.98	20.39	1.00
6	2	10	1001	565869.29	180012.83	19.03	0.46
6	3	11	1100	565868.85	179988.42	15.71	1.00
6	3	13	1300	565910.73	179972.59	15.63	1.00
6	3	15	1502	565954.62	179955.72	14.95	0.82
6	3	17	1701	566006.17	179941.73	13.45	1.00
6	3	21	2100	566073.53	179914.96	12.67	2.02
6	3	21	2101	566062.33	179918.63	12.77	2.10
6	3, 5	25	2500	566131.98	179909.89	11.96	1.97
6	3	25	2501	566150.23	179896.23	13.16	1.99
6	5	26	2600	566136.91	179924.20	12.12	1.71
6	5	26	2601	566143.96	179932.39	12.23	1.80
6	5	26	2602	566143.79	179938.43	12.29	1.95
6	5	28	2800	566159.91	179974.72	13.10	1.00
6	5	28	2803	566155.03	179962.48	12.92	1.90
6	4	31	3100	566228.13	180031.41	14.78	1.94
6	4	31	3101	566222.54	180037.31	14.81	2.10
6	4	32	3204	566186.30	180033.30	14.76	2.00
6	4	32	3205	566197.58	180024.60	14.37	2.05
6	4	33	3300	566247.34	180037.10	14.83	2.00
6	5	40	4001	566126.24	179846.90	11.82	0.60
6	5	40	4002	566126.20	179866.36	12.25	0.81

LP	Transect	Trench	Section	Easting	Northing	GL (m OD)	Total depth (m BGL)
6	5	4	4003	566126.09	179855.82	11.96	0.78
6	6	46	4600	566197.00	179744.97	14.63	2.28
6	6	46	4601	566215.87	179752.07	16.31	2.23
6	6	47	4700	566184.81	179755.48	13.88	2.30
6	6	47	4701	566164.29	179751.31	12.55	3.80
6	6	50	5000	566159.60	179738.51	12.18	4.04
6	6	50	5001	566148.12	179734.66	11.81	4.74
7a	7	90	9000	566215.03	179569.76	8.42	1.70
7a	7	90	9001	566220.51	179574.62	8.98	2.20
7a	7, 8	91	9101	566258.34	179538.26	8.18	1.50
7a	7, 8	91	9102	566261.54	179544.30	8.91	1.66
7a	8	91	9103	566270.51	179556.85	10.99	2.00
7a	8	91	AH9101	566258.69	179532.09	7.90	3.90
7a	8	91	AH9102	566256.48	179527.50	7.64	3.14
7a	8	91	AH9103	566254.02	179523.01	7.49	2.32
7a	7	92	9200	566284.47	179528.70	8.11	1.36
7a	7	95	9500	566311.72	179512.66	7.63	1.83
7a	7	96	9601	566359.31	179509.56	8.09	1.13
7a	7	97	9700	566393.26	179510.42	8.05	0.80
7a	7	97	9701	566390.93	179502.94	7.21	1.70
7a	8	103	10300	566244.17	179500.91	9.05	2.80
7a	8	103	10301	566252.93	179512.97	7.96	1.60
7a	8	103	10302	566254.19	179515.82	7.81	1.92
7a	8	103	AH10300	566252.55	179519.98	7.33	3.50
7b	9	110	11000	566523.36	179550.33	12.51	1.00
7b	9	113	11300	566608.35	179491.23	10.67	2.90
7b	9	115	11500	566645.05	179467.77	11.16	2.00
7b	9	116	11600	566670.39	179439.58	10.10	2.00
7b	9	117	11700	566685.71	179427.66	9.97	1.00
7b	9	118	11800	566714.32	179427.21	11.55	0.98
7b	9	120	12000	566728.00	179389.75	9.77	1.86
7b	10	122	12200	566825.09	179407.53	15.41	3.00
7b	10	122	12201	566833.78	179391.56	13.30	1.00
7b	10	123	12300	566875.50	179401.47	12.51	1.00
7b	9	125	12500	566760.65	179363.87	9.39	2.14
7b	10	127	12700	566849.22	179349.68	10.29	1.89
7b	10	127	12701	566843.03	179369.80	11.36	1.05
7b	9	129	12900	566778.37	179349.81	8.91	1.41
7b	9	132	13200	566840.42	179325.03	9.04	0.70
7b	9	132	13202	566828.10	179325.01	8.79	0.90
7b	10	133	13300	566864.81	179334.56	9.74	1.12
7b	9, 10	133	13301	566867.77	179314.42	8.84	1.99
7c	11	138	13800	566577.01	179339.64	7.38	1.13
7c	11	139	13900	566597.00	179326.78	7.40	0.63

LP	Transect	Trench	Section	Easting	Northing	GL (m OD)	Total depth (m BGL)
7c	11, 12	140	14000	566676.31	179298.58	6.72	1.94
7c	11, 12	140	14001	566675.62	179281.80	6.95	1.28
7c	11, 12	140	14002	566675.47	179276.73	7.05	1.06
7c	14	141	14100	566529.89	179313.71	9.47	1.10
7c	14	145	14500	566551.41	179263.80	10.47	0.98
7c	14	146	14600	566577.16	179233.99	10.27	1.95
7c	14	147	14700	566613.23	179196.25	9.48	2.00
7c	14	147	14701	566606.68	179203.11	9.74	2.00
7c	14	148	14800	566643.79	179169.33	8.65	1.80
7c	11	162	16200	566714.49	179276.26	6.65	1.84
7c	12	163	16300	566679.72	179233.76	7.98	1.76
7c	12	163	16301	566674.89	179250.90	7.87	1.70
7c	11	165	16500	566757.78	179244.38	6.03	1.00
7c	12	166	16600	566687.68	179208.91	7.62	1.30
7c	11	169	16900	566800.72	179209.38	6.15	2.00
7c	11, 13	170	17000	566834.62	179200.42	6.25	1.34
7c	11	171	17100	566876.28	179197.60	6.27	0.77
7c	12, 14	172	17200	566705.87	179146.94	9.10	1.05
7c	12	172	17201	566703.03	179167.57	8.62	0.95
7c	13	175	17501	566837.89	179160.96	7.71	1.74
7c	13	175	17502	566821.01	179162.60	7.60	0.74
7c	12, 14	177	17700	566737.33	179129.16	9.11	0.74
7c	14	178	17808	566777.81	179129.68	8.88	0.65
7c	14	178	17809	566760.13	179128.20	8.94	0.74
7c	13, 14	179	17900	566807.79	179130.13	8.63	1.54
7c	13	179	17901	566807.29	179134.28	8.60	1.81
7c	13	179	17902	566812.00	179116.02	8.80	0.74
7c	14	181	18101	566882.19	179125.77	8.57	0.45
7c	13	184	18402	566800.56	179094.10	9.42	2.34
7c	13	184	18404	566802.74	179073.93	9.92	0.78
7c	13	189	18900	566807.85	179055.33	10.05	2.06
	<b>Total</b>	<b>104</b>					

Table 30: Geoarchaeological transect locations

LP	Trench	Bulk	Monolith	OSL	Total
6	3	1			1
	4		1	4	5
	25	3	1		4
	26	2	4	9	15
	33	2	1		3
	40	1	1		2
	46		2	3	5
	50		1	2	3
7a	90	1	1	2	4
	91	4	2		6
	92	2	2		4
	95	1	3	5	9
	97		1		1
	103		1	3	4
	107	3	2	4	9
7b	113	5	5	4	14
	115		1	3	4
	123		1	2	3
7c	140	1			1
	141	1	2	1	4
	162	7		7	14
	170	2		2	4
	174	1			1
	175	2			2
8	230		1		1
	<b>Total</b>	<b>39</b>	<b>33</b>	<b>51</b>	<b>123</b>

Table 31: Summary of geoarchaeological samples

C.7.12 Overall, several broad sediment facies were recorded across the site. The results are presented below and are discussed in relation a series of composite transects incorporating key trench sequences.

- I. **Topsoil** - modern sandy ploughsoils
- II. **Made ground** – recent dumped deposits and disturbance associated with ground/vegetation clearance and levelling. Mixed deposits, frequently containing poorly sorted gravel, redeposited natural strata and debris. Mainly recorded in the valley base in Land Parcels 6 and 7a
- III. **Burnt deposits** - of probably recent origin associated with Unit II in Land Parcel 7a
- IV. **Colluvial ploughwash** – Later prehistoric and historic colluvium derived from arable agriculture. Soils eroded from upslope. Mid grey brown sandy silts with variable often poorly sorted clast content and reworked artefactual material., a product of rill and gully erosion and sheetwash. The composition reflects erosion of bedrock and Pleistocene drift geology immediately

upslope eg. deep very stony and bedded ploughwash was recorded downslope of the terrace gravels in Land Parcel 6 (Valley C), whereas elsewhere the colluvium appeared more homogenous, stone-free and massive, derived from brickearth-type slope deposits and reworked TSF.

- V. **Buried soils** – Intermittent variable dark grey to grey, generally thin beds of sandy silt located at the base of the ploughwash or weathered (sometimes bleached) horizons within the top of the fine-grained slope deposits (**Unit IX**). In the valley base they are more organic and sealed beneath peat sequences.
- VI. **Organic silt/clay and peat** – prehistoric (radiocarbon dated) wetland deposits dating from the early Neolithic to late Bronze Age (Trench 91, Land Parcel 7a). Located in the base of Valley A (Land Parcels 7a, 7c) and Valley B (Land Parcel 6). The top of the sequence is located relatively close to the surface. The upper levels have been subject to significant recent disturbance and churning probably due to vegetation clearance and levelling activities.
- VII. **Alluvium** – Relatively localised thin deposits of stoneless silt-clay, oxidised orange brown and mottled, sometimes gleyed blue grey, particularly associated with recent pond deposits in Land Parcel 7c.
- VIII. **Pale grey to white and/silts** - localised polygenetic deposits located towards the foot slopes and base of Valleys A and B, frequently below peat/organic Unit VI. In places, overlying fine-grained slope deposits (Unit IX), this unit appeared leached (E horizon?) and may be a product of incipient podzolization. However, some of these deposits, particularly in Land Parcel 7a appeared more calcareous closely resembling marl. In a small number of deeper profiles, a grey horizon within these deposits was tentatively identified as a possible stabilisation horizon.
- IX. **Sand silt (slopewash-brickearth)** – Sheetwash (?), pale yellowish brown and strong brown sands and silts, generally stone free or with limited clast content, gravel stringers. Brickearth type deposits potentially of both Pleistocene, late Glacial-early Holocene date derived from erosion of loess and/or Thanet Sand. In places sands appeared laminated/bedded.
- X. **Gravelly Head deposits** – variable, dense, cold climate Pleistocene solifluction deposits dominated by poorly sorted flint gravel and a sandy and/or clay matrix.
- XI. **Sand and gravel** – Loose, coarse grained Pleistocene fluvial terrace gravel, possibly reworked from higher upslope.
- XII. **Thanet Sand bedrock**

C.7.13 Where possible it is useful to make the distinction between later Holocene colluvium (hillwash/ploughwash) and Pleistocene-early Holocene slope deposits, which together are grouped as 'Head' by the BGS and during geotechnical investigations. However, it is recognised that this is not always possible in the field, particularly with earlier Holocene prehistoric sequences, deposits that derive from reworked Thanet Sand, or those that present as reddish brown argillic horizons (reworked tertiary? solution residue? or remnant Bt horizons). Key archaeological horizons may occur at the interface between the base of the Holocene colluvium and the earlier slope deposits/bedrock, where artefact scatters (LUP, Mesolithic/Neolithic, Bronze Age) may be preserved, sometimes in association with buried soils. Buried soils (and artefact scatters) may also occur within the Holocene colluvium.

## Land Parcel 6, Transects 1-6

- C.7.14 The sequences in Land Parcel 6 are represented in Transects 1-6 (Figs 46-51), and their locations are shown on Fig. 3. Here the bedrock geology is Thanet Sand Formation (TSF), but this was rarely recorded with certainty given the difficulty with separating it from the thick sands-silts of the overlying slope deposits (Unit IX) which is derived in part from erosion of TSF. Bedrock was recorded on the higher ground in the vicinity of Trenches 11 and 13 (Fig. 48, Transect 3) at depths of less than 1m BGL and was tentatively identified by augering at between 1.8 and 3.4m BGL in Trench 47 (Fig. 51, Transect 6).
- C.7.15 Fluvial sand and gravel deposits (possibly reworked) were noted on the higher ground in the vicinity of Trenches 8, 9 and 10 (Fig. 47, Transect 2) immediately below a colluvial subsoil at less than 0.5m BGL (Plate 27). Archaeological features were cut into the surface of the sand and gravel.
- C.7.16 Thick yellowish brown and strong sand-silt slope deposits (Unit IX) of probable Pleistocene age formed a large part of the sediment sequences exposed in Land Parcel 6. In places these deposits were quite sandy and appeared finely laminated/bedded on the slopes of Valleys A and B, Trenches 17, 21, 25 (Fig. 48, Transect 3), 31, 32 (Fig. 49, Transect 4), and 50 (Fig. 51, Transect 6). The deposits contained frequent evidence of weathering, carbonate and Fe leaching and re-precipitation down profile.
- C.7.17 Thick colluvial ploughwash deposits (Unit IV) were present within the thin deeply incised N-S Valley C in the eastern part of Land Parcel 6, extending to a maximum depth of 1.66m BGL in Trench 4. Here the colluvium was notably stoney and bedded, probably incorporating elements of reworked Terrace Gravel from the deposits capping the higher ground to the north. At the base of the colluvium in Trenches 4 (Plate 28) and 5 a possible buried soil was recorded (Fig. 46, Transect 1). In Trench 5 stakeholes [506] and [508] were located within the colluvial sequences at c 1.2m BGL, associated with later prehistoric pottery. The underlying colluvium (503) also produced several small sherds of middle Bronze Age to middle Iron Age pottery. In Trench 3 to the south, pit 321 within the upper part of the colluvium at c 1m BGL contained CBM and fragments of Roman pottery (Fig. 46, Transect 1).
- C.7.18 Elsewhere in Land Parcel 6 the colluvium appeared a little thinner but reached a depth of 1.18m BGL in Trench 25 (Fig. 48, Transect 3) and 1.55m BGL in Trench 31 (Fig. 49, Transect 4) in Valley B. In Trench 33 at the base of the colluvium at 1.68m BGL was a possible weathered horizon containing burnt flint and charcoal (Plate 29)
- C.7.19 In the base of Valley B, in Trenches 28, 26, and 25 (Plate 30; Fig. 50, Transect 5) pale sandy silts (Unit VIII) were overlain by organic silts and peat (Unit VI), which were sampled in Trenches 26 and 25. These sequences were stratigraphically very similar to those encountered in Land Parcel 7a (see below) but appeared locally disturbed/truncated, despite being buried at a depth of c 1m BGL beneath colluvium. Consequently, it was decided that radiocarbon dating and palaeoenvironmental work should be focused on better preserved sequences in Land Parcel 7a.

### **Land parcel 7a, Transects 7-8**

- C.7.20 The sequences in Land Parcel 7a are represented in Transects 7 and 8 (Figs 52 and 53) and their locations are shown in Fig. 4. Here the bedrock geology is Thanet Sand Formation (TSF). The higher areas of Land Parcel 7a generally comprise slope deposits similar to those described for Land Parcel 6. Geoarchaeological work focused on clarifying the deep sediments on the lower slopes and in the base of Valley A where several *in situ* (or little disturbed) flint scatters were recorded.
- C.7.21 The TSF bedrock was rarely seen and only tentatively identified at a depth of just over 2.6m BGL beneath fine grained-slope deposits (Unit IX) in in auger hole AH9101, between Trenches 91 and 103(Fig. 53, Transect 8).
- C.7.22 The base of Valley A in Land Parcel 7a appeared to be filled with these slope deposits and thick deposits of Unit VIII, here appearing as a marl-like deposit beneath a sequence of organic/peat deposits (Unit VI). A darker grey, slightly humic horizon in Trench 95 (Fig. 52, Transect 7, Context 9505; Plate 31) within the marl was radiocarbon dated to either the late Glacial using the insoluble sediment fraction at 10500-9880 cal BC (Beta-614814; 10290 ± 30 BP) or to the early Holocene period using the soluble fraction at 8230-7840 cal BC (Beta-614813; 8870 ± 30 BP). The base of the overlying organic deposits in Trench 91 (Fig. 53, Transect 8, Context 9109) was radiocarbon dated to the middle-late Neolithic at 3340-2920 cal BC (Beta-614817; 4420 ± 30 BP and Beta-614818; 4540 ± 30 BP). The uppermost peat deposit in Trench 91 (Fig. 53, Transect 8, context 9107) appears to have accumulated into the late Bronze Age, giving a radiocarbon date range of 970-820 cal BC (Beta-614819; 2750 ± 30 BP and Beta-614820; 2740 ± 30 BP; see Nicholson, Appendix C.6 this report and Plate 32) The base of the organic sequence, interpreted as a possible buried soil horizon, could be traced some way upslope in several trenches, and in Trench 103 was associated with *in situ* flint scatters of predominantly later Mesolithic date (Fig. 53, Transect 8).
- C.7.23 Across much of Land Parcel 7a the upper parts of the organic complex (Unit VI) appeared mixed, bioturbated, rooted and disturbed, with frequent post-medieval and more recent finds along with extensive areas of burning (Plate 10). The sequence in Trench 91, however appeared more intact and exhibited some intercalated bedding of organic silts and more humified peat (contexts 9107, 9119, 9120, 9108 and 9109, Plate 32).
- C.7.24 The sequence was sealed by relatively shallow depths of colluvial ploughwash and ploughsoils to c 0.5-0.75m BGL, although here the more recent finds would suggest this was of more recent date than elsewhere, possibly a result of ground levelling an infill. Localised deposits of made ground were also present overlying the organic deposits in the auger holes between Trenches 91 and 103 (Fig. 53, Transect 8).

### **Land Parcel 7b, Transects 9-10**

- C.7.25 The sequences in Land Parcel 7b are represented in Transects 9 and 10 (Figs 54 and 55) and their locations are shown on Fig. 4. Here the bedrock geology is Thanet Sand Formation (TSF). The site area was largely located on higher ground above the extant pond on the northern slopes of Valley A. Consequently, the majority of the deposits encountered consisted of colluvial ploughwash (Unit IV) overlying fine-grained slope deposits (Unit IX). Possible TSF bedrock was encountered in Trench

125, 129, 132 and 133 (Fig. 54, Transect 9) and Trench 122 (Fig. 55, Transect 10) in the eastern part of the land parcel. However, Land Parcel 7b is notable for the presence of coarse fluvial sand and gravel at depth (Unit XI). This was recorded in Trench 133 at 1.37m thick, to a depth of 1.89m BGL overlying TSF (Plate 33). Gravelly Head deposits were also note towards the base of the sequences in Trenches 113, 115, 120 and 127.

- C.7.26 The colluvial ploughwash was of variable thicknesses across the site. A possible buried soil was noted in Trench 113 (Fig. 54, Transect 9) at 0.86m BGL which produced struck flints and later prehistoric (MBA-MIA) pottery (11303), and further buried soils were recorded in Trench 120 at 1.28m BGL (Fig. 54, Transect 9) and Trench 123 (Fig. 55, Transect 10). Probably Roman CBM was recovered from colluvial layer 11601 in Trench 116, and pottery from colluvial layer 11602 (Fig. 54, Transect 9).

### **Land Parcel 7c, Transects 11-14**

- C.7.27 The sequences in Land Parcel 7c are represented in Transects 11 - 14 (Figs 56-59) and their locations are shown on Fig. 5. Here the bedrock geology is Thanet Sand Formation (TSF). The site was located on the south side of Valley A, sloping up from c 6m OD in the north at the edge of the extant pond, to a plateau at c 10m OD in the south. A shallow SW-NE aligned valley originates in the central part of the site, joining valley A to the NE.
- C.7.28 The TSF bedrock was recorded frequently across the higher ground in this land parcel largely due to the fact that several trenches were excavated up to 2m BGL to examine the pre-Holocene sequences (Fig. 57, Transect 12 Trench 163; Fig. 58, Transect 13 Trenches 175, 179, 184 and 189; Fig. 59, Transect 14 Trenches 146, 147, 148 and 179). The sequence was fairly consistent with coarse grained fluvial sand and gravel (Unit IX; Plate 34) overlain by gravelly Head (Unit X) and fine grained sand and silt slopewash (brickearth-type) deposits (Unit IX). Colluvial ploughwash (Unit IV) was present on the slopes but generally averaged 0.5m thick and in places was recorded more of subsoil layer.
- C.7.29 Variation in the sediment sequences was noted in the lower lying areas to the north adjacent to the extant pond (Fig. 56, Transect 11). Here a sequence similar to that on Land Parcel 7a was recorded. In Trenches 165, 169 and 170 the deposits included Unit VIII overlain by organic/peat deposit of Unit IV. Unlike Land Parcel 7a there were no burnt deposits or 'colluvium' (levelling deposits) and the sequence appeared to extend to beneath the current peaty topsoil. However, some of these trenches suffered from severe flooding and edge collapse after heavy rain and had to be recorded from the edge of excavation very rapidly. A significant depth of sandy deposits correlated with Unit IX was recorded in Trench 162 where there was question as to whether they represented the TSF or fluvial deposition and for this reason the opportunity was taken after discussion with the LTC Palaeolithic archaeologist to extract a full sequence of OSL samples (Fig. 56, Transect 11).
- C.7.30 The edge of a large undated pond-like feature [14003] infilled with gleyed bluish grey alluvial silty clay was located in Trench 140 (Plate 16). Unfortunately, the sides of the excavation became too unstable to allow further investigation.



## Land Parcel 8

- C.7.31 Land parcel 8 lay immediately east of 7c. This was a comparatively small area with fewer trenches and sequences here were unexceptional and very similar to 7c They largely comprise bodies and sand and silt correlated with Unit IX, which overlay gravelly Head (Unit X) and fluvial sand and gravel (Unit XI). TSF bedrock was not generally encountered.
- C.7.32 In the south on the higher ground, the gravelly Head and the sand and gravel were mainly encountered within 0.5m BGL or less, overlain by ploughsoils and subsoil. Trench 238 was extended to 2m BGL. Here, brickearth type deposits (Unit IX) extended to 0.6m BGL followed by gravelly Head and then sand and gravel to 2m BGL.
- C.7.33 South of Trenches 135 and 136, Unit IX thickened downslope. In Trench 231 the top of the fluvial gravel was reached at 1.7m BGL or more. The colluvial ploughwash deposits, however, remained relatively shallow up to 0.50m in thickness. No organic peat or alluvial sequences were noted in Land Parcel 8 towards the valley base.

## Discussion and conclusions

- C.7.34 Geoarchaeological investigations undertaken throughout Land Parcels 6, 7a-c and 8 focussed on the sedimentary sequences contained within four valleys (A-D). The largest, Valley A, is aligned E-W and is the equivalent of the Brook Farm Channel (Wenban Smith and Bates 2020, Zone PQ-15) and runs across the majority of the Land Parcels reported upon in this evaluation. This E-W valley-like landform connects the Mar Dyke Basin in the west with the Thames Channel in the south-east and may have acted as a drainage exit for the Mar Dyke during the Pleistocene. Little extant sub-surface data was available for PQ-15 prior to the current investigation, with the assumption the valley was probably infilled with a mixture of poorly-sorted flint gravel mixed with clay/silt/sand. The Palaeolithic potential was assessed as uncertain. The remaining three valleys (B-D) are smaller, aligned N-S, and feed into main valley A.
- C.7.35 The bedrock across the majority of the area is the Thanet Sand Formation which was recorded as such when clearly recognised. However, there was some ambiguity in many trenches regarding the nature of the fine-grained slope deposits which frequently resembled the TSF, particularly in Land Parcel 6 where the deposits appeared laminated/bedded. OSL samples were taken in several trenches to clarify this at a later date if required as part of the Palaeolithic investigations. As expected, most of the Pleistocene deposits comprised fine-grained slope deposits, although especially on higher ground these may be better described as brickearth-type deposits. Gravelly Head was noted in many trenches at depth. However coarser sand and gravel deposits, frequently clast supported with rounded, moderately sorted cobbles and pebbles were also encountered that may represent remnants of Terrace Gravel not mapped by the BGS. This gravel occurred almost at surface in the higher areas of Land Parcels 6, 7c and 8 as well as being buried at depth under slope deposits towards the base of the valleys. Key late Glacial and Holocene sequences were investigated in the base of Valley A (Land Parcel 7a: Trenches 90, 91, 92, 95, 96, 97, 98, 99 and 103) and Valley B (Land Parcel 6: Trenches 25 and 26) related to the development of wetland environments and peat formation. Similar sequences appeared to extend into Land Parcel 7c (eg. Trenches 165, 169, 170 and 171) but

poor ground conditions precluded detailed investigation. However, in Land Parcel 7a the upper parts of the sequence had been disturbed by levelling and infill activity.

- C.7.36 The best-preserved sequences in trenches that were accessible at depth prior to flooding were located in Land Parcel 7a and were sampled in Trenches 95 and 91. A series of radiocarbon dates have established that the sequence begins in the late Glacial or early Holocene, with peat formation commencing in the early Neolithic at 3340-3030 cal BC and continuing into the late Bronze Age to 970-820 cal BC. The peat was quite humified and dominated by degraded woody fragments and roots, and contained only sparse assemblages of waterlogged plant remains and occasional insect remains (see Cook, this report).
- C.7.37 Further work may be carried out to assess the preservation of diatoms, ostracods and pollen. This is particularly relevant for the earlier underlying marl-like deposits, to ascertain whether they are water-lain or represent a leached sub-facies of the underlying fine-grained slope deposits. It is almost certain that processes related to weathering, fluctuating groundwater and down-valley drainage through the TSF and Pleistocene sands and silts have produced a complex of post-depositional transformations involving leaching, re-precipitation of carbonates and Fe panning. Locally ash-grey layers take on the appearance of incipient podzolization. In the valley base, however, the late Glacial to early Holocene marl-like deposits may be related to wetland development, which it is important to characterise given the close proximity of *in situ* or little disturbed Mesolithic flint scatters.
- C.7.38 The deeper colluvial ploughwash sequences investigated in the valley locations were generally unexceptional, and as they were mainly derived from the TSF bedrock and overlying Pleistocene slope deposits they frequently appeared homogenous and decalcified. More stoney bedded colluvium was noted in Valley C at the eastern end of Land Parcel 6, probably derived from the erosion of Terrace Gravels upslope. Sporadic buried soils were noted however in numerous trenches, at the base of the colluvium, at the interface with the underlying fine-grained slope deposits, on occasion associated with burnt flint, worked flint and charcoal. Based on artefactual dating and occasional features the colluvium is likely to date from the later prehistoric and historic periods.

## Appendix D      References

---

- ACBMG, 2007 *Ceramic building material, minimum standards for recovery, curation, analysis and publication*
- Allen, T, Barclay, A, Cromarty, A- M, Anderson-Whymark, H, Parker, A, Robinson, M, and Jones, G, *Opening the wood, making the Land; The Archaeology of a Middle Thames Landscape, Mesolithic, Neolithic and Bronze Age*, Vol 1, Oxford: Oxford Archaeological Unit. Thames Valley Landscapes Monograph 38
- Atkinson, D and Oswald, A, 1969 London clay tobacco pipes, *Journal of the British Archaeological Association* **32**, 171-227
- Atkinson, M and Preston, S J, 2015 Heybridge: A late Iron Age and Roman settlement. Excavations at Elms Farm 1993-5. Volume 2, *Internet Archaeology* **40**, <https://doi.org/10.11141/ia.40.1>
- Ballin, T B, 2011 The Levallois-like approach of Late Neolithic Britain: a discussion based on finds from the Stoneyhill Project, Aberdeenshire. In Saville, A. *Flint and Stone in the Neolithic Period*. Oxford: Oxbow Books, 37-61
- Ballin, T B, 2021 *Classification of Lithic Artefacts from the British Late Glacial and Holocene Periods*. Oxford, Archaeopress
- Bamford, H M, 1985 *Briar Hill. Excavation 1974–1978*, Northampton Development Corporation Archaeological Monograph **3**. Northampton: Northampton Development Corporation
- Barford, P, 1988, Salt production equipment (briquetage), in D Bond *Excavation at the North Ring, Mucking, Essex*, East Anglian Archaeology 43, 39-41
- Barford, P, 2016, Fired clay, in C Evans, G Appleby, and S Lucy, with Appleby, J and Brudenell, M, 2016 *Lives in the Land. Mucking Excavations by Margret and Tom Jones, 1965-1978: Prehistoric, Context and Summary*, Oxbow Books, 196-8
- Barrett, J C, 1988 Pottery, in D Bond *Excavation at the North Ring, Mucking, Essex*, East Anglian Archaeology **43**, 25-37
- Barton, N and Roberts, A, 2004 The Mesolithic Period in England: Current Perspectives and New Research. In Saville, A. (ed.) *Mesolithic Scotland and its Neighbours*. Society of Antiquaries of Scotland. Edinburgh, 339- 358
- Barton, K J, 1962 Settlements of the Iron Age and Pagan Saxon periods at Linford, Essex, *Trans Essex Archaeol Soc*, Vol 1-2, 57-104
- Biddulph, E, Compton, J, and Martin, T S, 2015 The late Iron Age and Roman pottery, in Atkinson and Preston 2015, <http://dx.doi.org/10.11141/ia.40.1.biddulph1>

- Booth, P, Champion, T, Foreman, S, Garwood, P, Glass, H, Munby, J and Reynolds, A, 2011 *On track: the archaeology of High Speed 1 Section 1 in Kent*. Oxford
- Bond, D, 1988 *Excavation at the North Ring, Mucking, Essex*. Essex County Council: East Anglian Archaeology Report No. **43**
- Brickley, M and McKinley, J I (eds), 2004 *Guidelines to the Standards for Recording Human Remains*, IFA Paper No. 7, British Association for Biological Anthropology and Osteoarchaeology (BABAO) and IFA
- British Geological Survey, 2019 *Geology of Britain Viewer*. Retrieved from <http://mapapps.bgs.ac.uk/geologyofbritain/home.html>
- Bronk Ramsey, C, 2009 Bayesian analysis of radiocarbon dates, *Radiocarbon* **51**(1), 337–360
- Brothwell, D R, 1981 *Digging up bones*. Oxford, Oxford University Press
- Brown, N, 1998 Earlier Iron Age pottery, in G A Carter *Excavations at the Orsett 'Cock' Enclosure, Essex, 1976*, East Anglian Archaeology **86**, 88-9
- Brudenell, M, 2016a Late Bronze Age Pottery, in C Evans, G Appleby and S Lucy, with J Appleby and M Brudenell *Lives in the Land. Mucking Excavations by Margret and Tom Jones, 1965-1978: Prehistoric, Context and Summary*, Oxbow Books, 158-88
- Brudenell, M, 2016b Middle Iron Age Pottery, in C Evans, G Appleby and S Lucy, with J Appleby and M Brudenell *Lives in the Land. Mucking Excavations by Margret and Tom Jones, 1965-1978: Prehistoric, Context and Summary*, Oxbow Books, 365-93
- Butler, C, 2005 *Prehistoric Flintwork*. Tempus. Stroud
- Cappers, R T J, Bekker R M and Jans, J E A, 2012 *Digital Seed Atlas of the Netherlands*. Groningen Archaeological Studies **4**. 2nd Edition, Barkhuis Publishing, Eelde, The Netherlands
- Carter, G A, 1998 *Excavations at the Orsett 'Cock' Enclosure, Essex, 1976*, East Anglian Archaeology **86**
- Champness, C, Donnelly, M, Ford, B M and Haggart, A, 2015 'Life at the floodplain edge: Terminal Upper Palaeolithic and Mesolithic flint scatters and early prehistoric archaeology along the Beam River Valley Dagenham', *Essex Archaeol. Hist.* **6**, 5-45
- Chartered Institute for Archaeologists (CIfA), 2014a *Standard and Guidance for Archaeological Evaluation*
- Chartered Institute for Archaeologists (CIfA), 2014b *Standard and guidance for the creation, compilation, transfer and deposition of archaeological archives*

- Conneller, C, Bayliss, A, Milner, N and Taylor, B, 2016 The Resettlement of the British Landscape: Towards a chronology of Early Mesolithic lithic assemblage types. *Internet Archaeology* **42**
- Cooper, L P and Jarvis, W, 2017 Making and breaking microliths: A Middle Mesolithic site at Asfordby, Leicestershire. *Proc Prehist Soc* **83**, 43-96
- Cotter, J P, 2000 *Post-Roman Pottery from Excavations in Colchester 1971-1985*, Colchester Archaeological Report **7**
- Drury, P J and Rodwell, W J, 1973 Excavations at Gun Hill, West Tilbury. *Trans Essex Archaeol Soc* **5**, 48-112
- Evans, C, Appleby, G and Lucy, S with Appleby, J and Brudenell, M, 2016 *Lives in the Land. Mucking Excavations by Margret and Tom Jones, 1965-1978: Prehistoric, Context and Summary*. CAU Landscape Archives Series (No.2/Mucking 6)
- Going, C J, 1987 *The Mansio and other sites in the south-eastern sector of the Caesaromagus: The Roman pottery*, CBA Res Rep **62**, London
- Griffiths, S, 2014 Points in Time: The Mesolithic-Neolithic transition and the chronology of late rod microliths in Britain. *Oxford Journal of Archaeology* **33 (3)**, 221-243
- Hamerow, H, 1993 *Excavations at Mucking vol.2: the Anglo-Saxon settlement*. English Heritage
- Healey, E, and Robertson-Mackay, R, 1983 The lithic industries from Staines causewayed enclosure and their relationship to other Earlier Neolithic industries in southern Britain. *Lithics—The Journal of the Lithic Studies Society* **4**, 1-27
- Hedges, J and Buckley, D, 1978 Excavations at a Neolithic Causewayed Enclosure, Orsett, Essex, 1975. *Proc Prehist Soc* **44**, 219-308
- Hedges, R E M, Housley, R A, Law, I A and Bronk, C R, 1989 Radiocarbon dates from the Oxford AMS system: Archaeometry datelist 9. *Archaeometry* **31 (2)**, 207-234
- Highways England, 2017 *LTC EIA Scoping Report: online document HE540039-CJV-GEN-GEN-REP-ENV-00001*
- Hillson, S, 1996 *Dental Anthropology*. Cambridge, Cambridge University Press
- Historic England, 2011, *Environmental Archaeology: A Guide to the Theory and Practice of Methods, from Sampling and Recovery to Post-excavation*
- Historic England, 2015, *Geoarchaeology: Using an earth sciences approach to understand the archaeological record*

- Jacobi, R M, 1980a The Early Holocene settlement of Wales, in J.A. Taylor (ed.), *Culture and environment in prehistoric Wales*. Oxford: British Archaeological Reports (British Series) 76, 131-206
- Jacobi, R M, 1980b The Mesolithic of Essex, in Buckley, D. G. (ed.) *Archaeology in Essex to AD 1500*, Council for British Archaeology Research Report **34**, 14-25
- Jacobi, R, 1994 Mesolithic radiocarbon dates: a first review of some recent dates, in N. Ashton and A. David (eds.) *Stories in Stone*. Lithic Studies Society Occasional Paper **4**, 192-198
- Jacobi, R M, 1996 The Late Upper Palaeolithic and Mesolithic in Essex, in O. Bedwin (ed.) *The Archaeology of Essex; Proceedings of the Writtle Conference* Chelmsford: Essex County Council, 10-14
- Jacomet, S, 2006. *Identification of cereal remains from archaeological sites*. Basel University, Basel
- Jefferies, R and Lucy, S, 2016 Romano-British pottery, in S. Lucy and C. Evans, *Romano-British settlement and cemeteries. Mucking excavations by Margaret and Tom Jones, 1965-1978*, Oxford, 154-199
- Jones, A P, Tucker, M E and Hart, J K, 1999, Guidelines and Recommendations, in *The description and analysis of Quaternary stratigraphic field sections*, Technical Guide No. 7. (eds A. P. Jones, M. E. Tucker and J. K. Hart), Quaternary Research Association: London, 27-76
- Jones, M U and Rodwell, W J, 1973 The Romano-British Pottery Kilns at Mucking, *Trans Essex Archaeol Soc* **5**, 13-47
- Leivers, M, Barnett, C and Harding, P, 2007 'Excavation of Mesolithic and Neolithic flint scatters and accompanying environmental sequences at Tank Hill Road, Purfleet, 2002', *Essex Archaeol. Hist.* **38**, 1-44
- Lewis, J S C with Rackham, J, 2011 *Three Ways Wharf, Uxbridge: A Late Glacial and Early Holocene hunter-gatherer site in the Colne Valley*. Museum of London Monograph **51**. London
- Linford Methodist Church, 2000 *Linford's History*  
<http://www.linfordmethodistchurch.co.uk/annivbook.htm#EARLY%20HISTORY%20OF%20LINFORD>
- Lucy, S and Evans, C, 2016 *Romano-British Settlement & Cemeteries, Mucking Excavations by Margaret and Tom Jones 1965-1978*. CAU Landscape Archives Series (No.3/Mucking 5)
- Major, H, 1998 Kiln Furniture, in G A Carter, *Excavations at the Orsett 'Cock' Enclosure, Essex, 1976*. East Anglian Archaeology 86, 70
- Medlycott, M ed., 2011 *Research and Archaeology Revisited: A Revised Framework for the East of England*. East Anglian Archaeology Occasional Paper 24: Association of Local Government Archaeological Officers

- McKinley, J I, 2004. Compiling and skeletal inventory: disarticulated and co-mingled remains. In M. Brickley and J. I. McKinley (eds.), *Guidelines to the Standards for Recording Human Remains*, IFA Paper No. 7, BABAO, 14-7
- Miles, A E W, 1962 Assessment of the ages of a population of Anglo-Saxons from their dentitions. *Proceedings of the Royal Society of Medicine* **55**, 881-6
- Mitchell, P D and Brickley, M (eds.), 2017 *Updated guidelines to the standards for recording human remains*. Chartered Institute for Archaeologists (CIfA) and BABAO
- MoLA, 2014a London medieval and post-medieval pottery codes, Museum of London Archaeology, <http://www.mola.org.uk/medieval-and-post-medieval-pottery-codes> (Accessed 11 Jan 2019)
- MoLA, 2014b London medieval and post-medieval ceramic building material codes, Museum of London Archaeology, <https://www.mola.org.uk/medieval-and-post-medieval-ceramic-building-materials-fabric-dating-codes> (Accessed 23 Nov 2021)
- MoLA, 2014c London Roman ceramic building materials: fabrics, dating, groups, sources and distribution codes, Museum of London Archaeology, <https://www.mola.org.uk/roman-ceramic-building-materials-fabrics-dating-fabric-groups-sources-and-distribution-codes> (Accessed 23 Nov 2021)
- Morris, E, 2012, Briquetage, in T Allen, M Donnelly, A Hardy, C Hayden, C and K Powell, *A Road Through the Past: Archaeological discoveries on the A2 Pepperhill to Cobham road-scheme in Kent*, Oxford Archaeology Monograph **16**, 228-45
- Oxford Archaeology, 2005 East Tilbury and Linford, Essex, Archaeological Evaluation Report, unpublished report
- Oxford Archaeology, 2016 Neolithic, Bronze Age and Modern activity at Bata Fields, East Tilbury, Essex, Excavation Report, unpublished report
- Oxford Archaeology, 2020a *Lower Thames Crossing Scheme-wide Written Scheme of Investigation for Trial Trenching south of the River Thames, V. 3*
- Oxford Archaeology, 2020b *Lower Thames Crossing Scheme-wide Written Scheme of Investigation for Trial Trenching north of the River Thames V.5*
- Oxford Archaeology, 2021 Lower Thames Crossing Detailed Written Scheme of Investigation Q for Trial Trenching of Land Parcels 6-8 and 131-134, Document Number: HE540039-BAL-GEN-GEN-REP-HER-00050, Version 1.1
- Oxford Cotswold Archaeology (OCA), 2020a *Lower Thames Crossing Archaeological Evaluation Report for Trial Trenching of Land Parcel 5, Brook Farm, Chadwell St Mary, Essex*. Oxford: Oxford Cotswold Archaeology

- Oxford Cotswold Archaeology (OCA), 2020b *Lower Thames Crossing Archaeological Evaluation Report for Trial Trenching of Land Parcel 3, Hornsby Lane, Orsett Heath, Essex*. Oxford: Oxford Cotswold Archaeology
- Oxford Cotswold Archaeology (OAC), 2021a *Lower Thames Crossing Archaeological Evaluation Report for Trial Trenching of Land Parcels 6, 8, 9, 10 and 36, Land between East and West Tilbury, Essex*. Oxford: Oxford Cotswold Archaeology
- Oxford Cotswold Archaeology (OCA), 2021b *Lower Thames Crossing Archaeological Evaluation Report for Trial Trenching of Land Parcel 37, Land at East Tilbury, Essex*. Oxford: Oxford Cotswold Archaeology
- Palmer, J J, 2019 *Open Domesday*. <https://opendomesday.org/place/>: University of Hull
- PCRG, SGRP, MPRG, 2016 *A standard for pottery studies in archaeology*, Prehistoric Ceramics Research Group, Study Group for Roman Pottery, and the Medieval Pottery Research Group
- Pietrzak, B and Slusarczyk, M, 2006 The fate of ehippia – Daphnia dispersal in time and space, *Polish Journal of Ecology* **54(4)**, 709-714
- Place Services, 2019 *Lower Thames Crossing Aerial Investigation and Mapping Report, Essex County Council*
- Poole, C, 1995 Loomweights versus oven bricks, in Cunliffe, B, 1995 *Danebury: an Iron Age hillfort in Hampshire Volume 6 A hillfort community in perspective*, CBA Res. Rep. **102**, 285-6
- Poole, C, 2012 Briquetage and Fired Clay, Specialist Report 8, in E Biddulph, S Foreman, E Stafford, A Stansbie and R Nicholson, *London Gateway: Iron Age and Roman salt making in the Thames Estuary. Excavations at Stanford Wharf Nature Reserve, Essex*, online specialist report: <https://library.thehumanjourney.net/909/>
- Poole, C, 2015 Fired Clay and Briquetage, in Andrews, P, Booth, P, Fitzpatrick, A P and Welsh, K, *Digging at the Gateway: Archaeological landscapes of south Thanet The Archaeology of East Kent Access Phase II Volume 2: The Finds and Environmental Reports*, Oxford Wessex Archaeology Monograph No. **8**, 289-323
- Potter, T W, 1974 An Iron Age Site at Rainbow Wood, Thurrock, Essex. *Essex Archaeology and History* **6**, 1-12
- Primeau, C, Arge, S O, Boyer, C and Lynnerup, N 2015 A test of inter and intra-observer error for an atlas method of combined histological data for the evaluation of enamel hypoplasia, *Journal of Archaeological Science: Reports*, **2**, 384-388



- Reimer, P, Austin, W, Bard, E, Bayliss, A, Blackwell, P, Bronk Ramsey, C, Butzin, M, Cheng, H, Edwards, R, Friedrich, M, Grootes, P, Guilderson, T, Hajdas, I, Heaton, T, Hogg, A, Hughen, K, Kromer, B, Manning, S, Muscheler, R, Palmer, J, Pearson, C, van der Plicht, J, Reimer, R, Richards, D, Scott, E, Southon, J, Turney, C, Wacker, L, Adolphi, F, Büntgen, U, Capano, M, Fahrni, S, Fogtmann-Schulz, A, Friedrich, R, Köhler, P, Kudsk, S, Miyake, F, Olsen, J, Reinig, F, Sakamoto, M, Sookdeo, A, & Talamo, S, 2020 The IntCal20 Northern Hemisphere radiocarbon age calibration curve (0–55 cal kBP), *Radiocarbon*, **62**
- Reynier, M J, 2005 *Early Mesolithic Britain: Origins, development and directions*. British Archaeological Reports (British Series) No. **393**
- Roberts, C and Manchester, K, 2005 *The Archaeology of Disease*. Third Edition. Stroud, Sutton Publishing
- Saville, A, 1981a Mesolithic Industries in Central England: an exploratory investigation using microlith typology. *Archaeological Journal* **138**, 49-71
- Saville, A, 1981b Honey Hill, Elkington. A Northants Mesolithic site. *Northamptonshire Archaeology* **16**, 1-13
- Schofield, T, 2010 *Mill House Farm, Chadwell St Mary, Essex, Archaeological Evaluation*, Archaeological Solutions Ltd
- Schweingruber, F H, 1990 *Microscopic Wood Anatomy; Structural variability of stems and twigs in recent and subfossil woods from Central Europe*. 3rd edition. Birmensdorf, Eidgenössische Forschungsanstalt WSL
- Sheridan, J A, 2008 Towards a fuller, more nuanced narrative of Chalcolithic and Early Bronze Age Britain 2500-1500 BC, *Bronze Age Review* **1**, 57-78, <http://repository.nms.ac.uk/401>
- Smoothy, M D, 1993 *Horndon-Coalhouse Fort (Tilbury) Gas pipeline, Archaeological report, Linford H-CHF93*.
- Stace, C, 2010 *New Flora of the British Isles*, 3rd Edition. Cambridge: CUP
- Stuiver, M and Polach, H A, 1977 Reporting of <sup>14</sup>C data, *Radiocarbon* **19**, 355–363
- Switsur, V R and Jacobi, R M, 1979 A Radiocarbon Chronology for the Early Postglacial Stone Industries of England and Wales, in Berger, R. and Suess, H. E. (eds.) *Radiocarbon Dating: Proceedings of the ninth international Conference Los Angeles and La Jolla 1976*. London: University of California Press, 41-68
- Tomber, R and Dore, J, 1998 *The National Roman fabric reference collection: a handbook*, MoLAS Monograph **2**, London
- website, Map of Essex, 2019 (original 1777)). <https://map-of-essex.uk/>

Wenban-Smith, F, and Bates, M, 2020, *Lower Thames Crossing, Palaeolithic and Quaternary Deposit Model (PQDM), and Preliminary Assessment of Archaeological Potential*, Client Report



**PINS Planning Inspectorate**

**RAMS Risk Assessment Method Statement**

**SMC Scheduled monument consent**

**TDR Trusted Digital Repository**

**UKIC United Kingdom Institute for Conservation**

**WSI Written Project of Investigation. A detailed method statement for archaeological work**

**WSL – Western Southern Link**

**The Western Southern Link (WSL) is an alternative for Short List Routes 2, 3 and 4 to the**

**south of the River Thames.**

## Appendix F Site Summary

---

Site name:	Lower Thames Crossing Land Parcels 6-8, Land West of Linford, East Tilbury, Essex
Site code:	LTC7T21
Grid Reference	NGR 566625, 179242
Type:	Evaluation
Date and duration:	13th July to 18th October 2021.
Area of Site	33.05 ha.

### Location of archive:

The archive from LTC7T21 (Land Parcels 6,7 and 8) will form part of the overall trial trenching scheme archive. This will be deposited in a repository consistent with the standards required by the Museums and Galleries Commission following completion of the archaeological phase of this project. This may either be with the local receiving museum in Thurrock or, if no such repositories are available, with a repository for the whole project designated by LTC. LTC retain the overall responsibility for the successful deposition of the project archive.

Currently, the archive is held at Oxford Archaeology's head office, Janus House, Osney Mead, Oxford, Oxfordshire, OX2 0ES. Oxford Archaeology will store the archive for LTC for a maximum period of 2 years following the completion of the project. If the storage of the archive at OA's office extends past this period, an extension to the storage period and final deposition timetable will be reviewed by OA and LTC and agreed with the major stakeholders.

### Summary of Results:

Oxford Cotswold Archaeology was commissioned by Balfour Beatty to undertake a trial trench evaluation of land parcels 6, 7 and 8 covered by WSI Q of the Lower Thames Crossing Pre-Enabling Works. These land parcels are located directly west of Linford with the county of Essex and Thurrock unitary authority (NGR 566625 179242). A total of 224 trenches were dug and recorded between 13th July and 18th October 2021.

The evaluation recorded a variety of archaeological activity, with the earliest evidence represented by at least two possible late Upper Palaeolithic flint blades. These were recovered from amongst a much more substantial assemblage of later Mesolithic flint artefacts that were identified as surface scatters across Trenches 97, 98, 99, 103, 104, 105, 107, 109 and 113, in the fills of tree-throw holes and natural features in Trenches 138, 139 and 141 and residually in features in Trenches 176 and 234 further east. Mesolithic activity was concentrated towards the base of the valley, most clearly in Land Parcel 7a, but also extending eastwards across Land Parcel 7b and the north ends of Land Parcels 7c and 8. Together these indicate an occupation area of regional importance.

It is possible that an element of the extensive flint scatters may prove to be of early Neolithic date, as the flint technology is very similar, but no diagnostic pieces of this date have yet been found in association with them. Evidence for early Neolithic activity was otherwise indicated by a small number of features and deposits bearing either flintwork or pottery of possible early Neolithic date. These were widely dispersed across the site and tended to occur without any clear focus. This pattern continued into the later Neolithic and early Bronze Age with the recovery of occasional flintwork and a single sherd of possible Beaker pottery recovered from a later feature.

No certainly middle Bronze Age features or finds were identified, although several undated concentrations of charcoal and burnt flint were found that may represent burnt mounds, which are typically of middle or late Bronze Age date. A small number of features dated to the late Bronze Age were recorded including a pit in Land Parcel 6 which produced a large assemblage of pottery and numerous fragments of briquetage. Activity that is more likely of late Bronze Age than early Iron Age date was concentrated in the western part of the site. The main focus of Iron Age settlement, in contrast, was in the east of the site across Land Parcels 7c, where a number of trenches revealed a concentration of pits, ditches and postholes that continued and developed into the middle Iron Age, extending into Land Parcel 8.

Pottery of late Iron Age/early Roman fabrics tended to be associated with definitely early Roman pottery, making identification of a separate late Iron Age phase uncertain. In the early Roman period,

activity was concentrated in Land Parcel 8, overlapping with the area of Iron Age settlement. A perforated kiln plate indicates the presence of a kiln nearby. Ditches of early Roman date followed two predominant orientations, suggesting a field or enclosure system, and these also mirror the lines of some Iron Age ditches, suggesting a degree of continuity of field or enclosure boundaries. The proximity of the Roman activity to the cropmark enclosure just east of the evaluated part of Land Parcel 8 may indicate that the enclosure was also of Roman date.

Early to middle Anglo-Saxon evidence was limited to two sherds of pottery from a pit in the northern part of Land Parcel 6. Several undated features were recorded in the vicinity including a rectangular enclosure previously identified as a cropmark, which may indicate a broader focus of activity contemporary with the pit. A little distance to the south-east was a ditch dating to the Saxo-Norman period.

In the centre of Land Parcel 7a, and extending across several trenches in the valley bottom, was a spread of pits dating from the 11th to 13th centuries. Although no structural evidence was directly associated with these, the assemblage of pottery and environmental remains suggest a domestic setting and perhaps the presence of a farmstead. It is possible that the double-ditched enclosure evident as a cropmark just to the north of these, which was confirmed but not dated by the evaluation, was a stock enclosure associated with this domestic activity.

Several post-medieval boundary ditches were located by the evaluation, some also marked on historic maps. Among other undated features was a crouched inhumation recorded in Trench 176, which contained residual finds of prehistoric pottery and flint, but for which insufficient collagen remained to obtain a radiocarbon date. Although crouched burials are found at several periods in prehistory and into the early Roman period, the burial is most likely to be later Bronze Age or Iron Age in date.

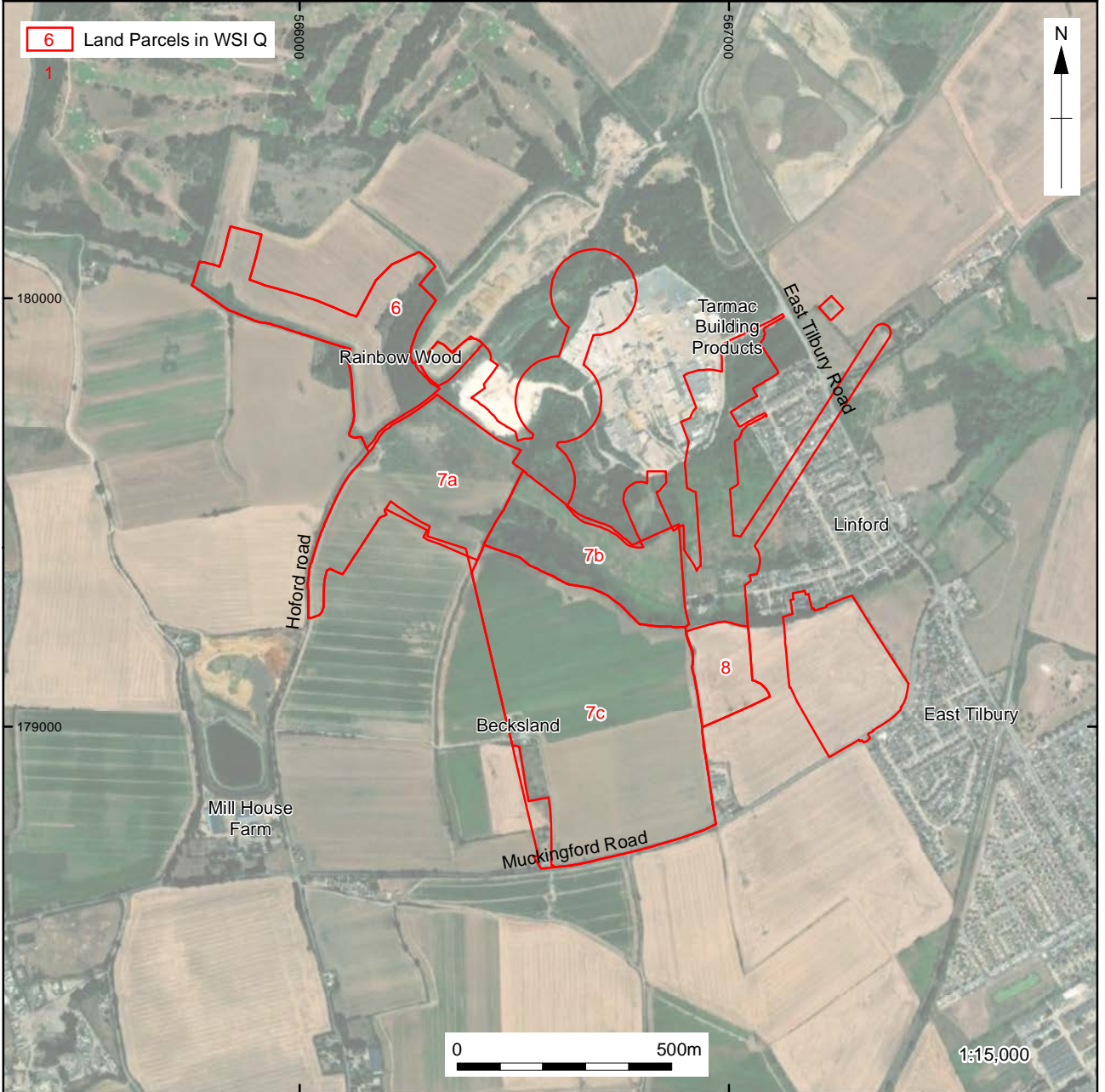
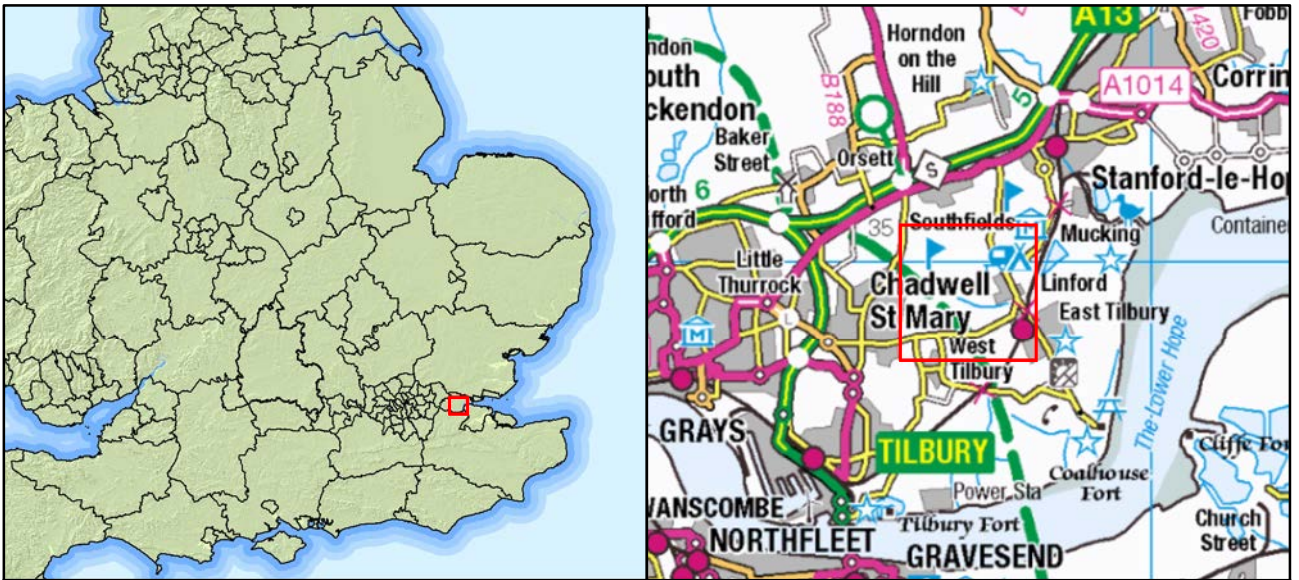

\\10.0.10.86\Projects\IL TCEV\_Lower\_Thames\_Crossing\1010\Geomatics\03 GIS Projects - LTC7L21\Figures\TC7L21\_Report\_Fig 1.mxd\* caroline.souday\*20/12/2021

Source: Esri, Maxar, GeoEye, Earthstar Geographics, CNES/Airbus DS, USDA, USGS, AeroGRID, IGN, and the GIS User Community  
 Contains Ordnance Survey data © Crown copyright and database right 2016

Figure 1: Site location

X:\IL\TCEV\_Lower\_Thames\_Crossing\010\Geomatics\03 GIS Projects - LTC7L21\Figures\LTC7L21\_ReportV2\_Fig2.mxd\caroline.souday\21/12/2021

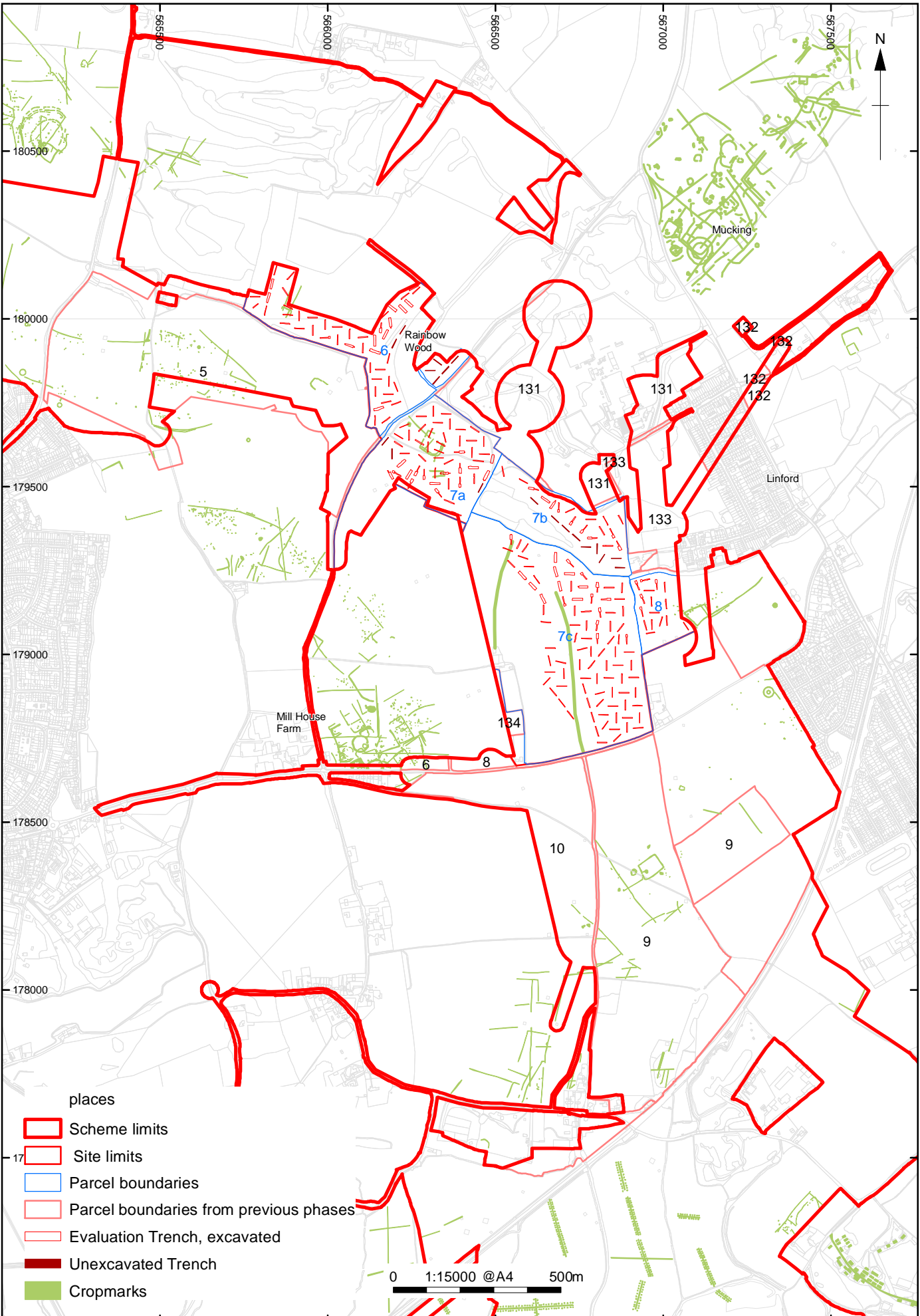

Contains Ordnance Survey data © Crown copyright and database right 2020, provided by client

Figure 2 : Trench layout and cropmark features, Land Parcels 6, 7a/b/c and 8



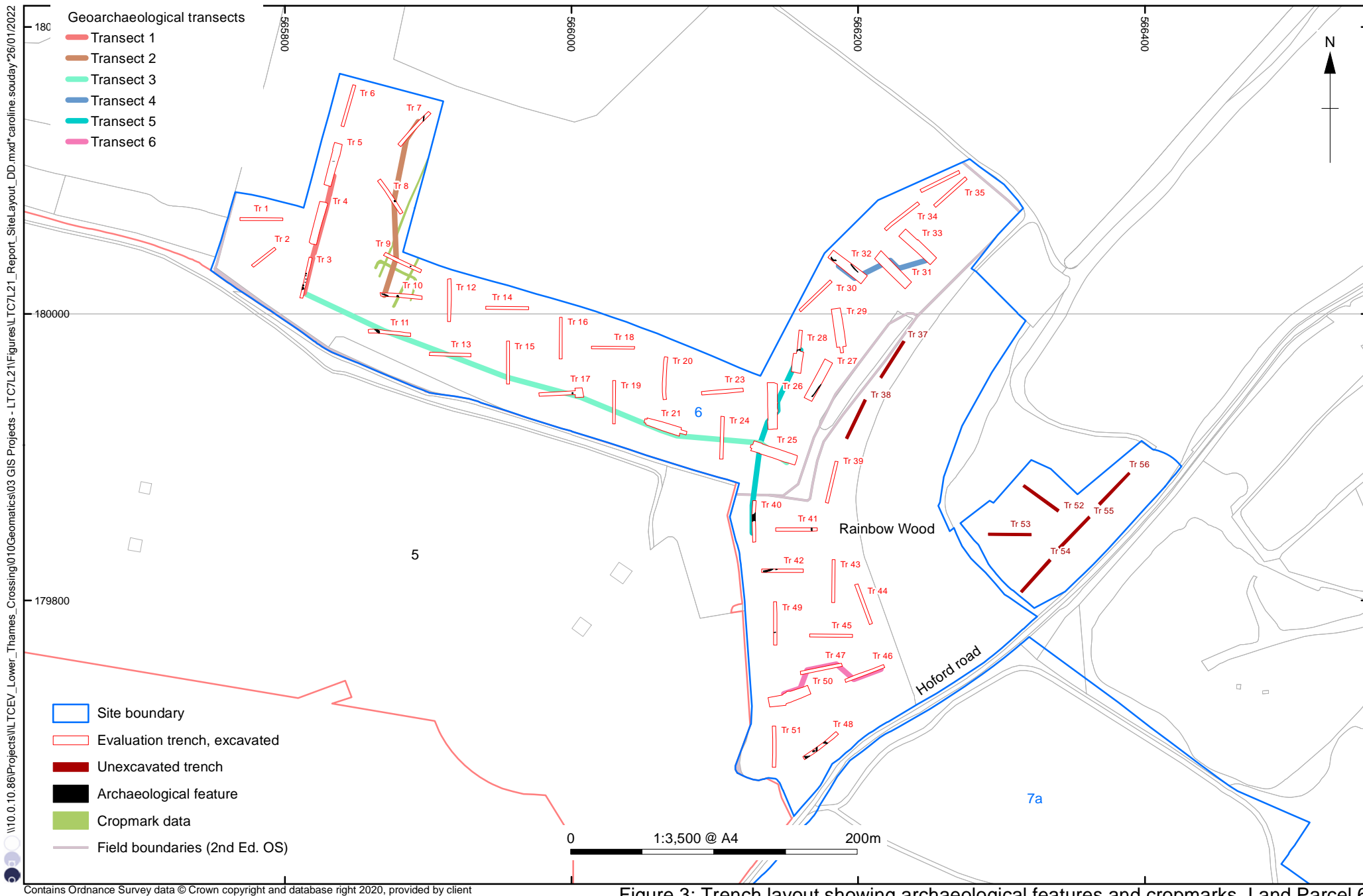

Figure 3: Trench layout showing archaeological features and cropmarks, Land Parcel 6

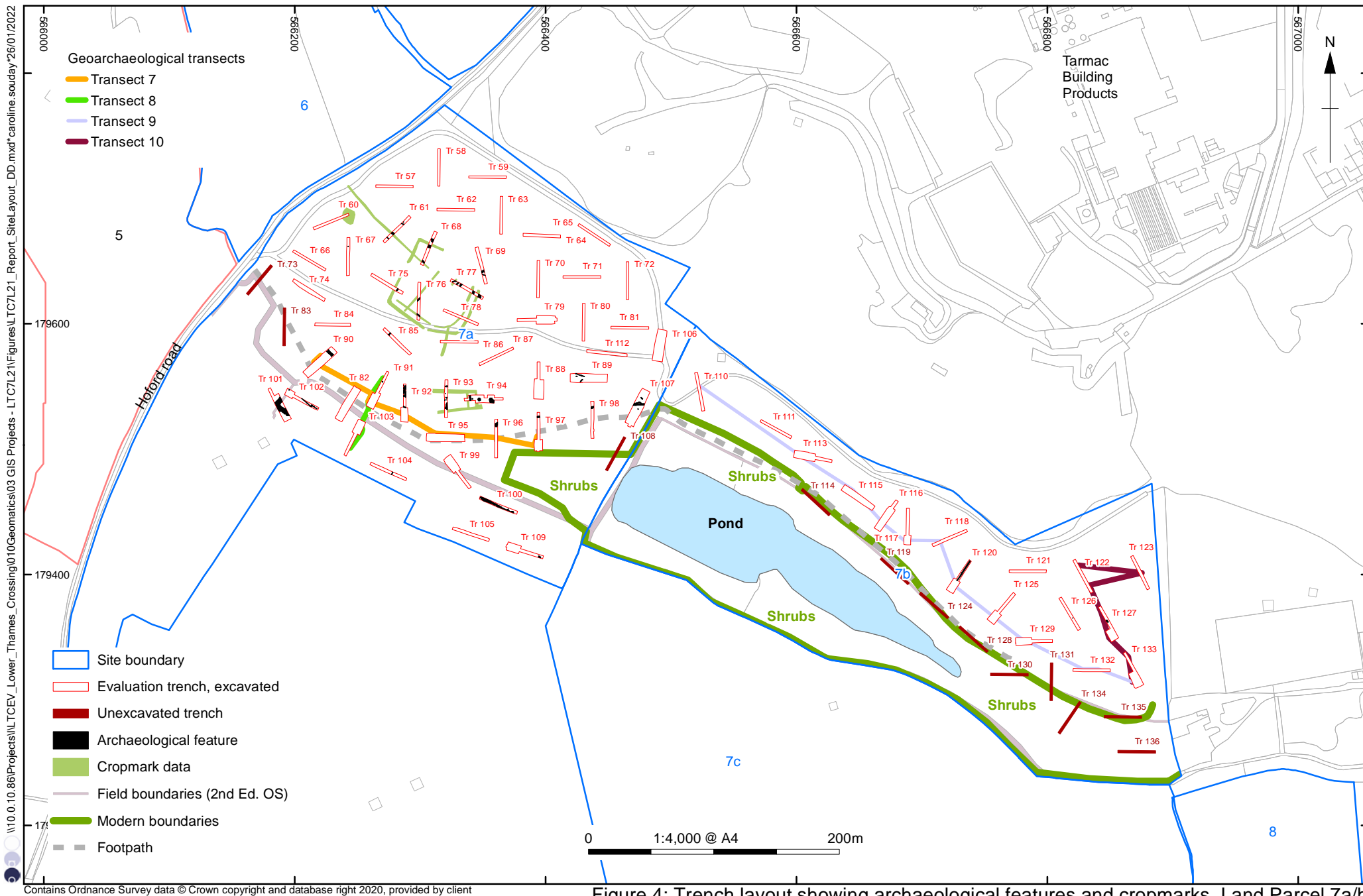

Figure 4: Trench layout showing archaeological features and cropmarks, Land Parcel 7a/b

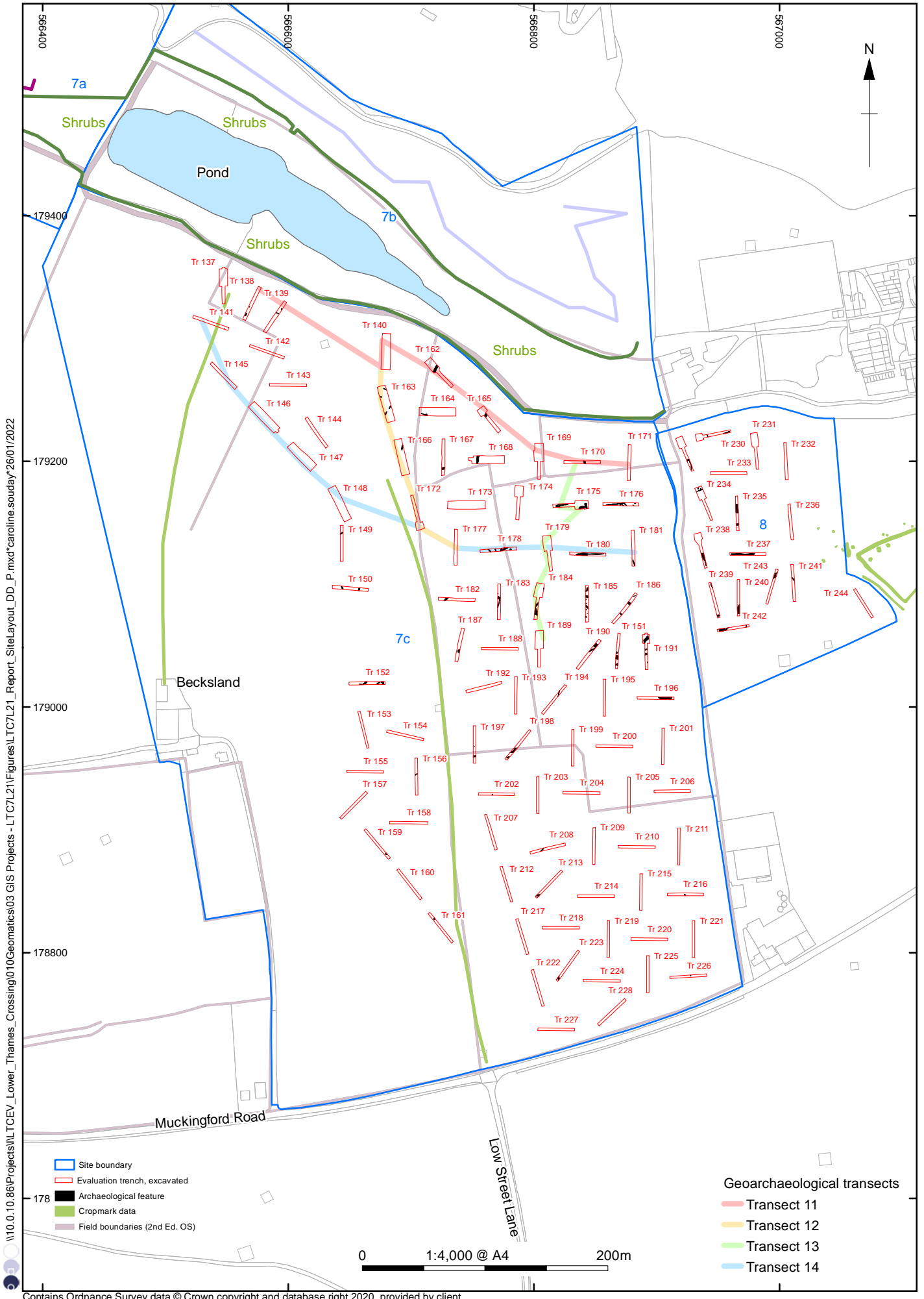
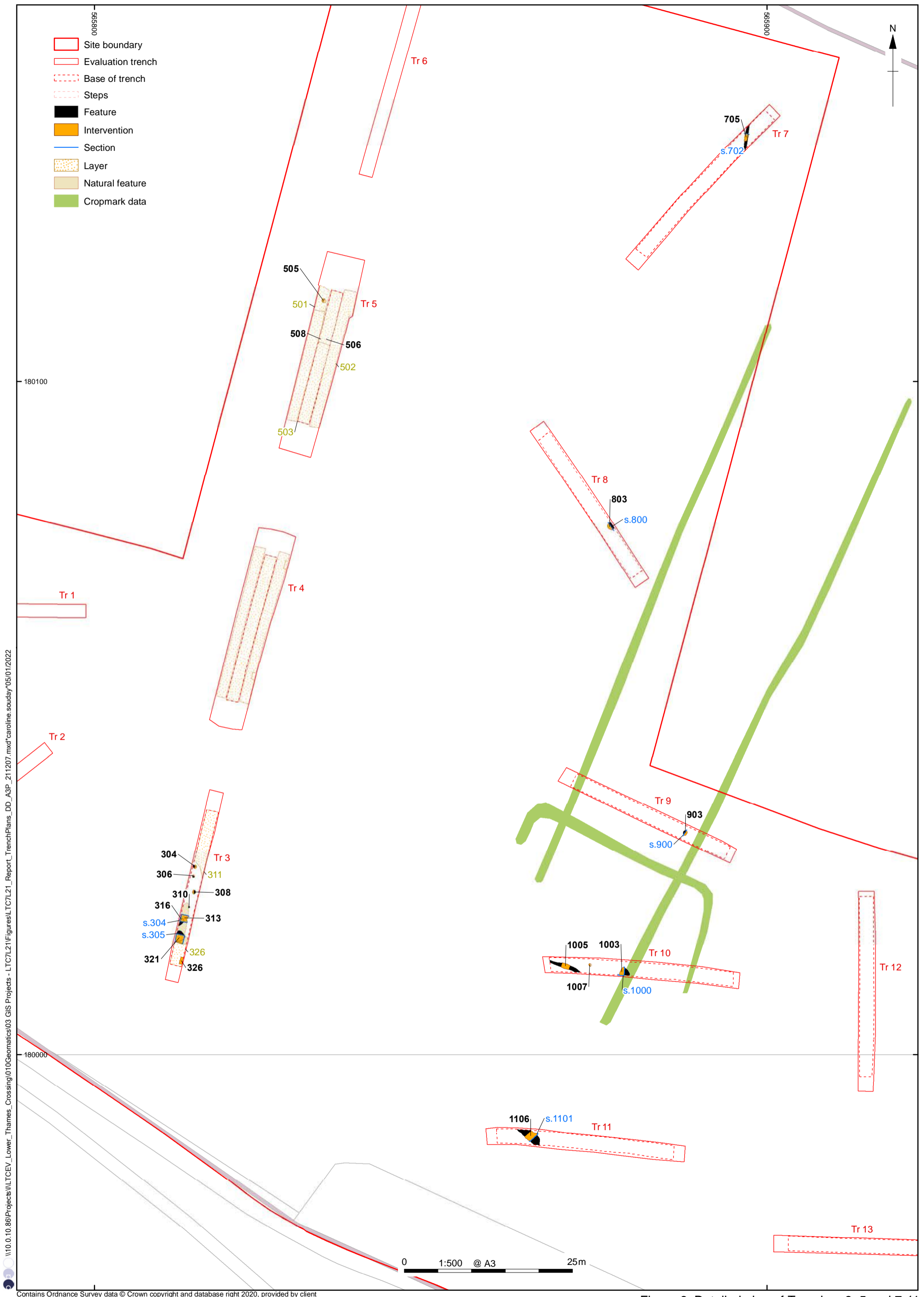

Figure 5: Trench layout showing archaeological features and cropmarks, Land Parcels 7c and 8



I:\10.0.10.86\Projects\Lower\_Thames\_Crossing\010\Geomatics\03 GIS Projects - L7C7L2\1\Figures\L7C7L21\_Report\_TrenchPlans\_DD\_A3P\_211207.mxd\*caroline.souday\*05/01/2022

Contains Ordnance Survey data © Crown copyright and database right 2020, provided by client

Figure 6: Detailed plan of Trenches 3, 5 and 7-11

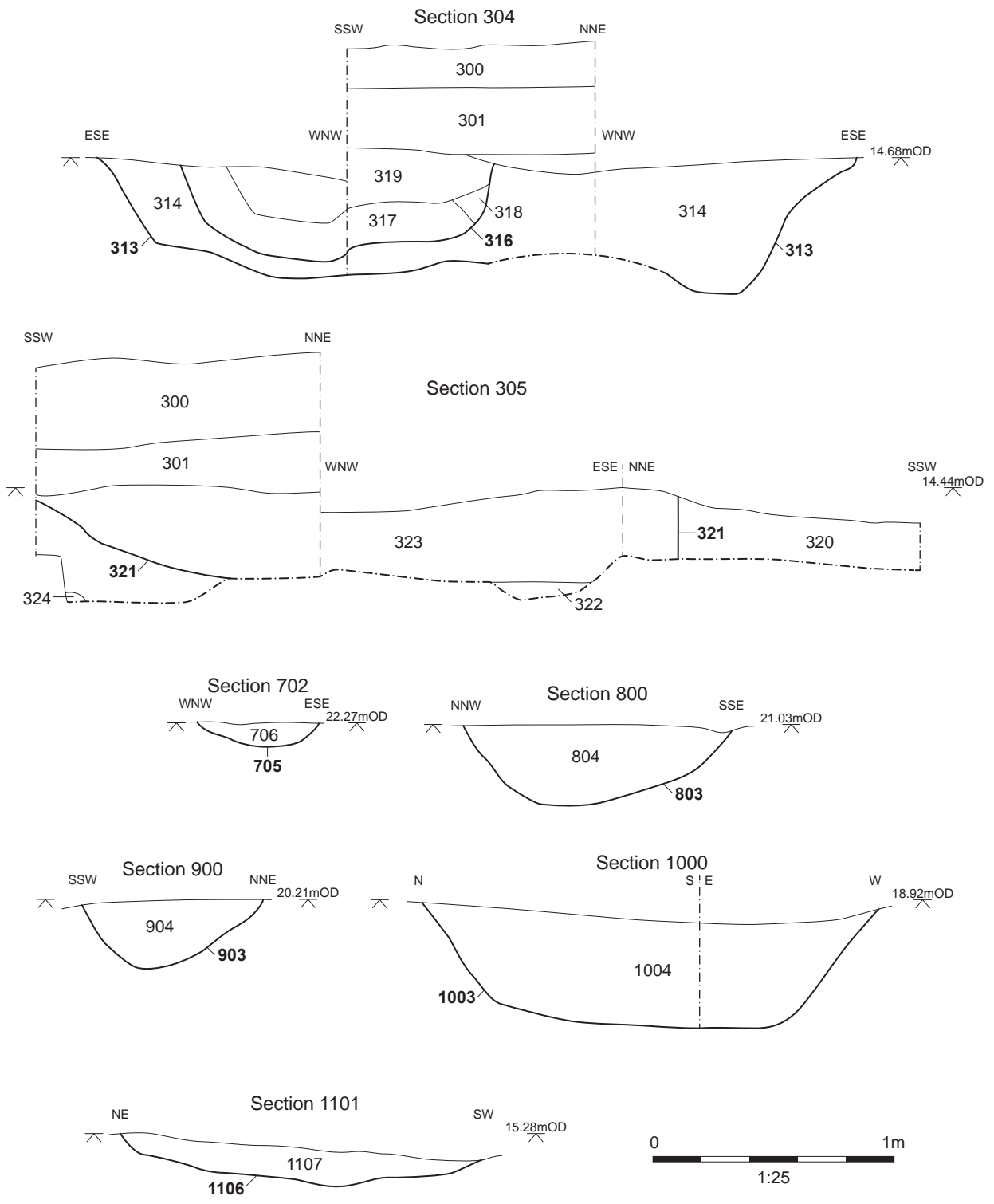
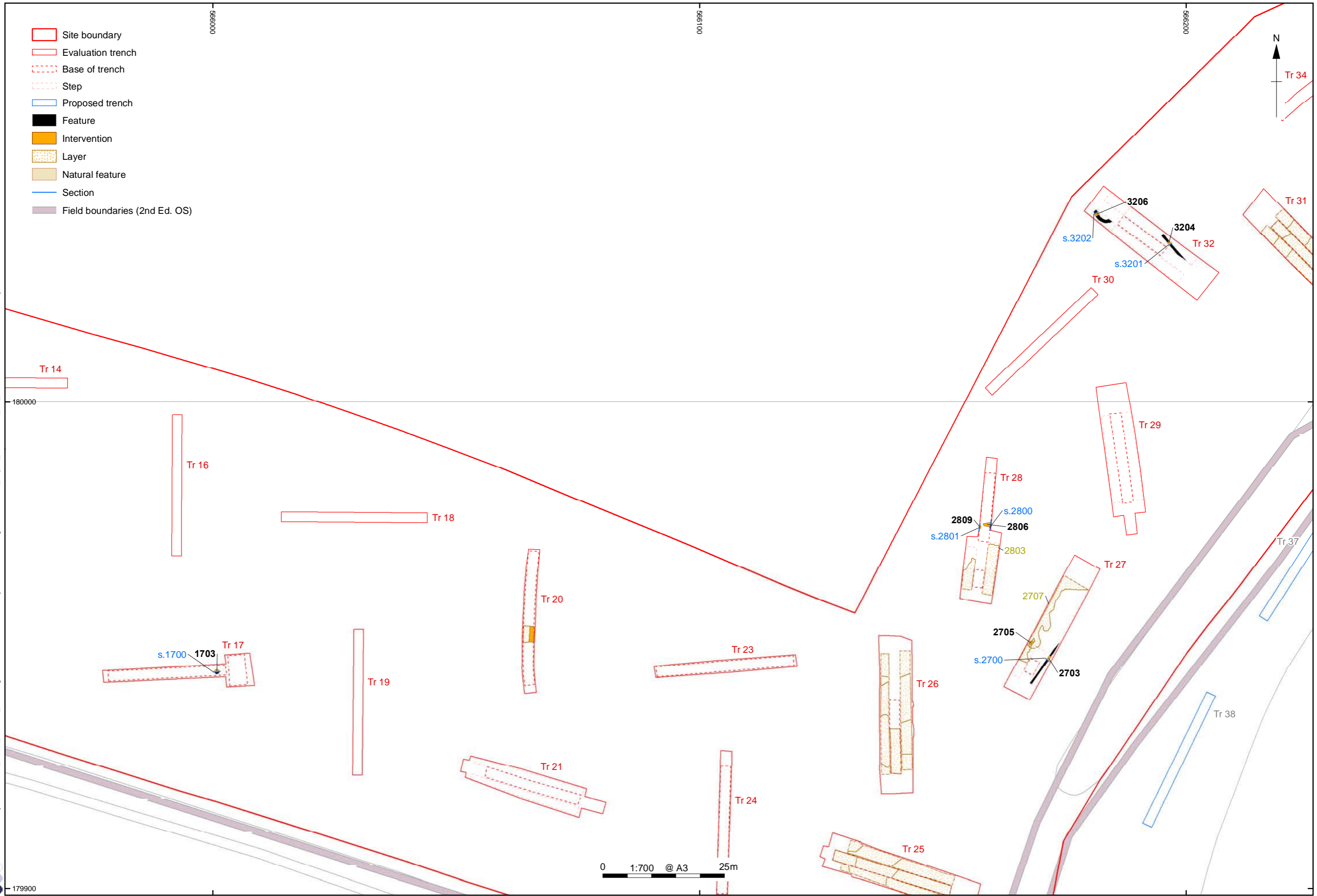

Figure 7: Sections 304, 305, 702, 800, 900, 1000, 1101

\\10.0.10.86\Projects\IL TCEV\_Lower\_Thames\_Crossing\010\Geomatics\03 GIS Projects - L TC7\21\Figures\TC7\21\_Report\_TrenchPlans\_DD\_A3\211207.mxd\caroline.souday\2601\2022



Contains Ordnance Survey data © Crown copyright and database right 2020, provided by client

Figure 8: Detailed plan of Trenches 17, 27, 28 and 32

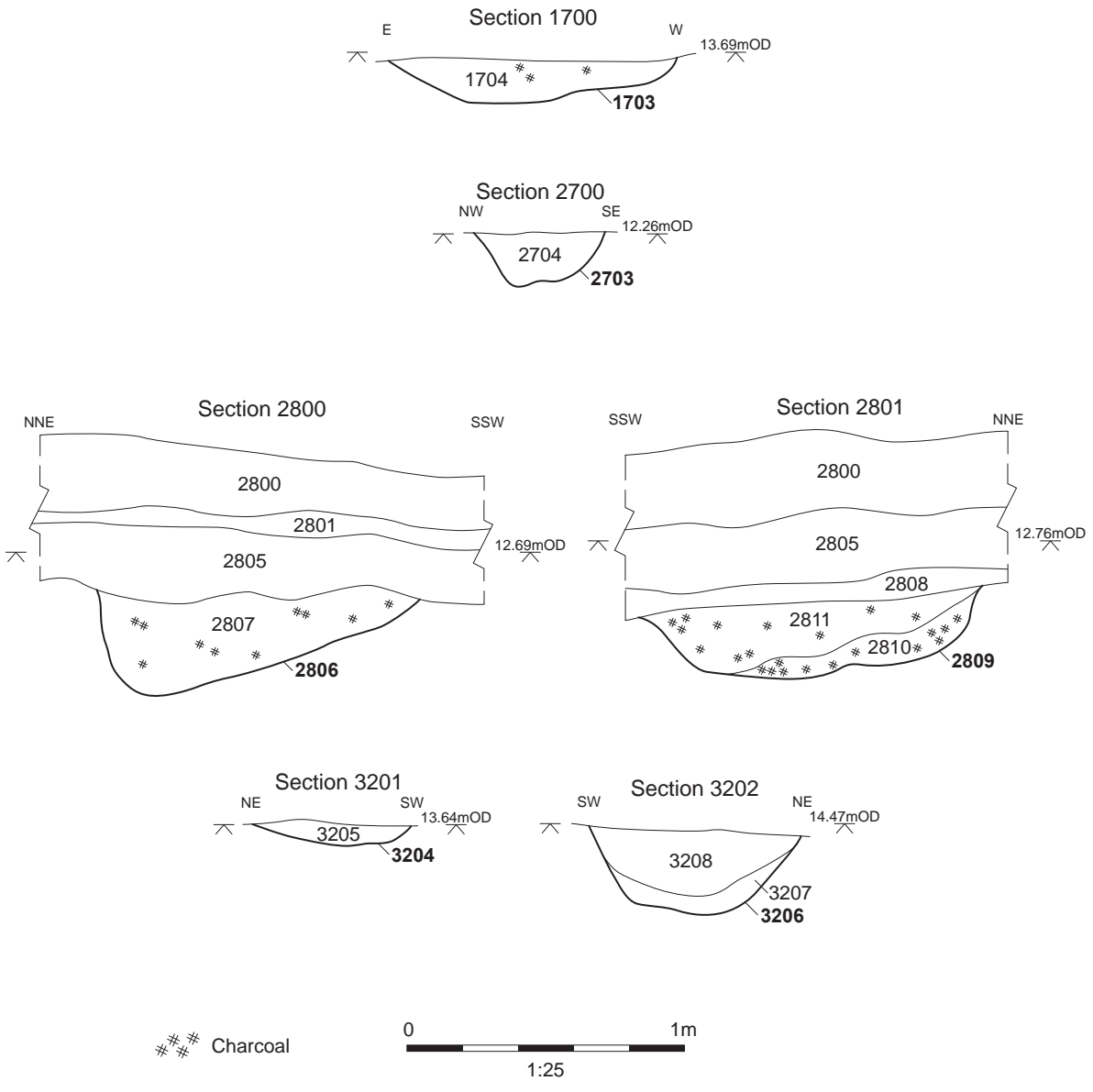
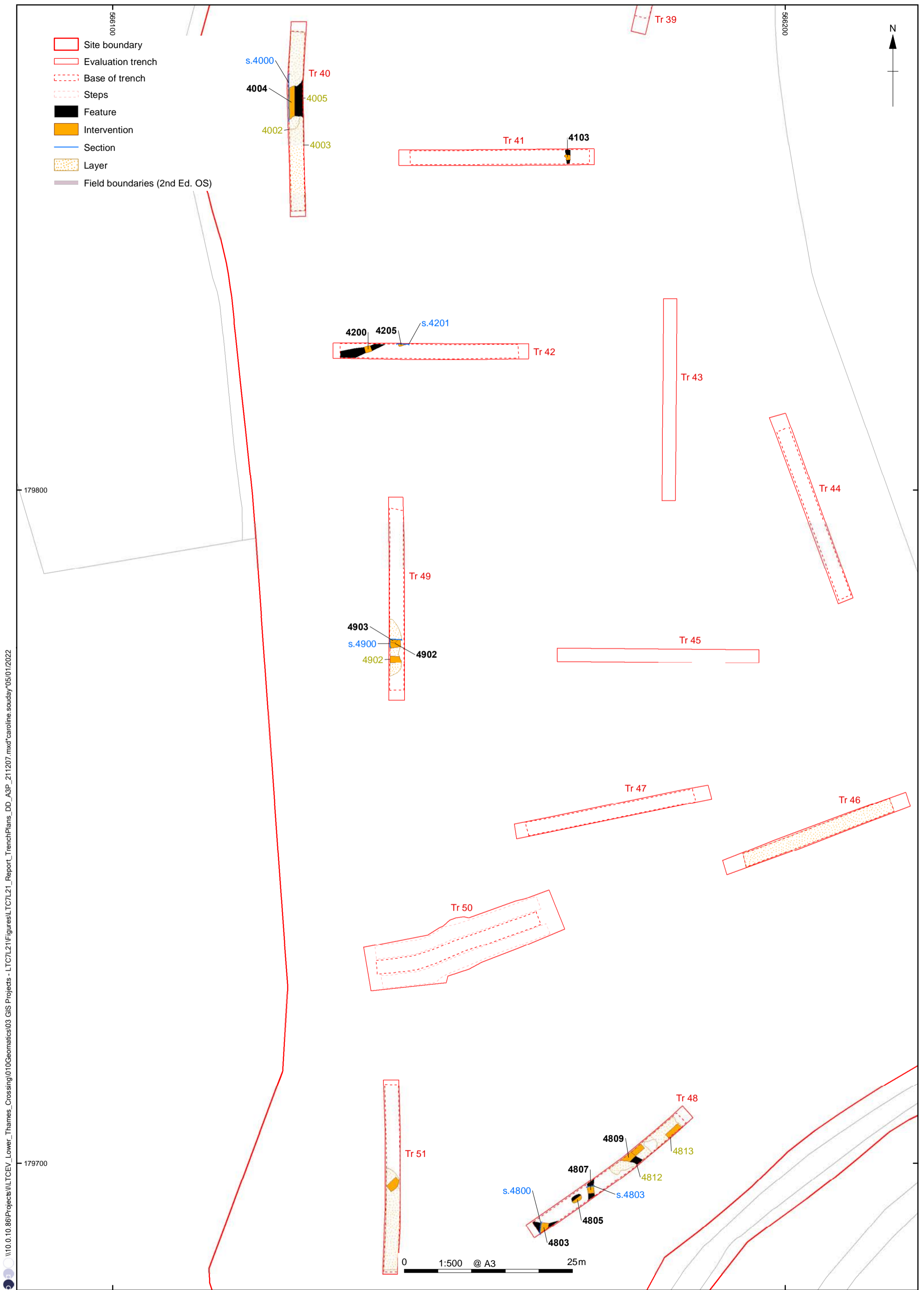

Figure 9: Sections 1700, 2700, 2800, 2801, 3201, 3202



\\10.0.10.86\Projects\Lower\_Thames\_Crossing\010\Geomatics\03 GIS Projects - LTC7L2\Figures\LTC7L21\_Report\_TrenchPlans\_DD\_A3P\_211207.mxd\*caroline.souday\*05/01/2022

Contains Ordnance Survey data © Crown copyright and database right 2020, provided by client

Figure 10: Detailed plan of Trenches 40, 41, 42, 48 and 49



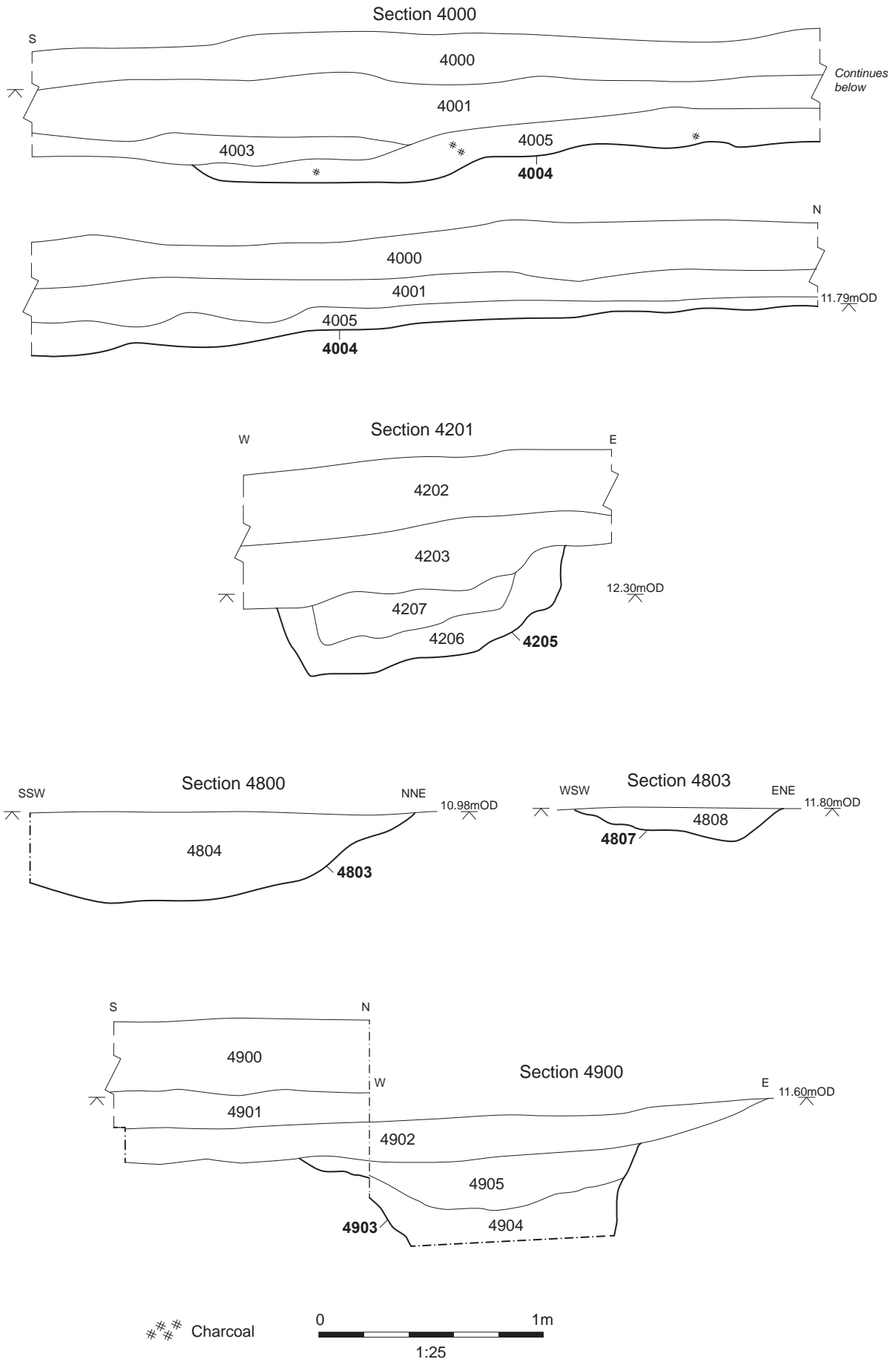
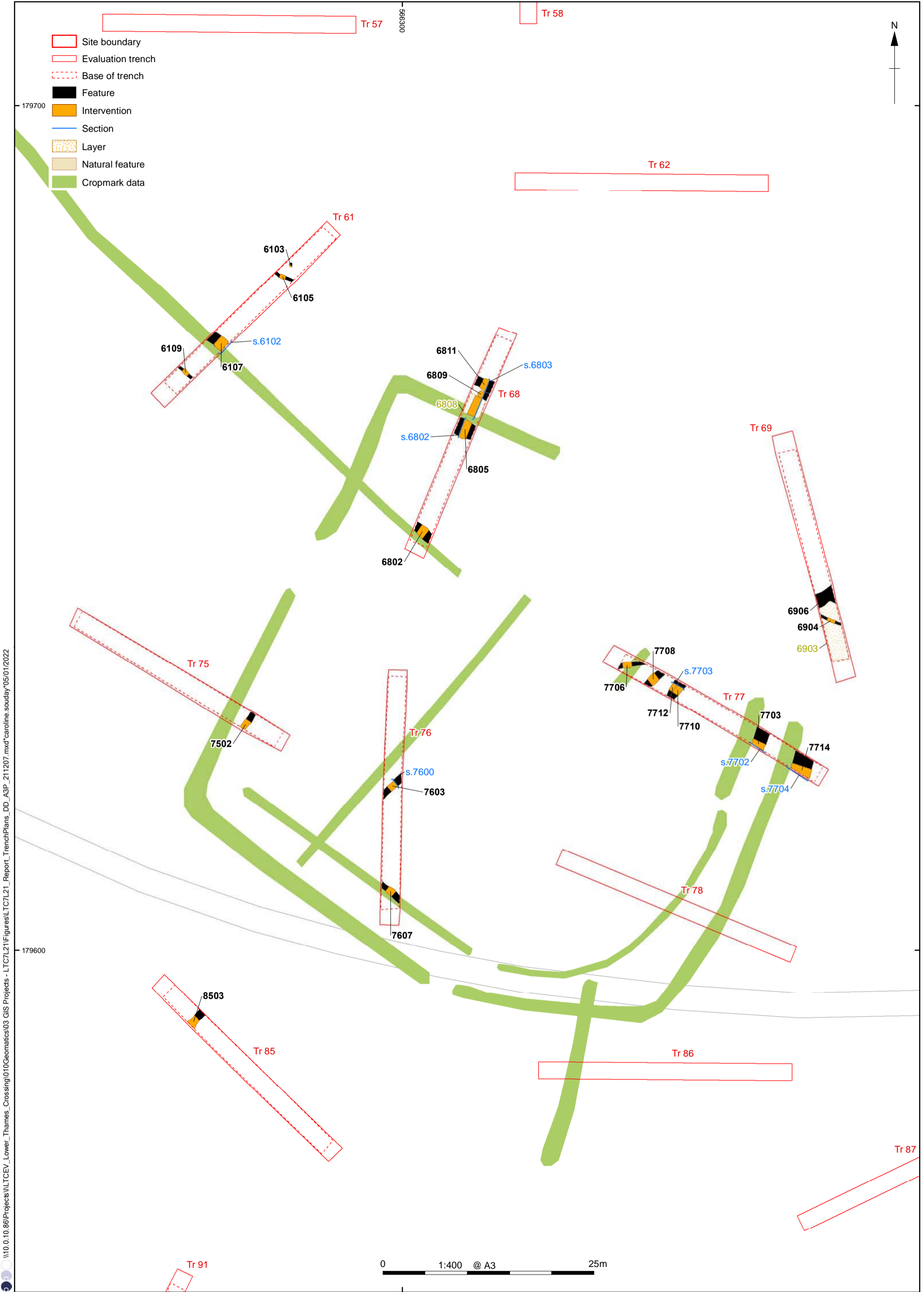

Figure 11: Sections 4000, 4201, 4800, 4803, 4900



I:\10.0.10.86\Projects\Lower\_Thames\_Crossing\010\Geomatics\03 GIS Projects - LTC7L2\Figures\LTC7L21\_Report\_TrenchPlans\_DD\_A3P\_211207.mxd\*caroline.souday\*05/01/2022

Contains Ordnance Survey data © Crown copyright and database right 2020, provided by client

Figure 12: Detailed plan of Trenches 61, 67-9, 75-7 and 85

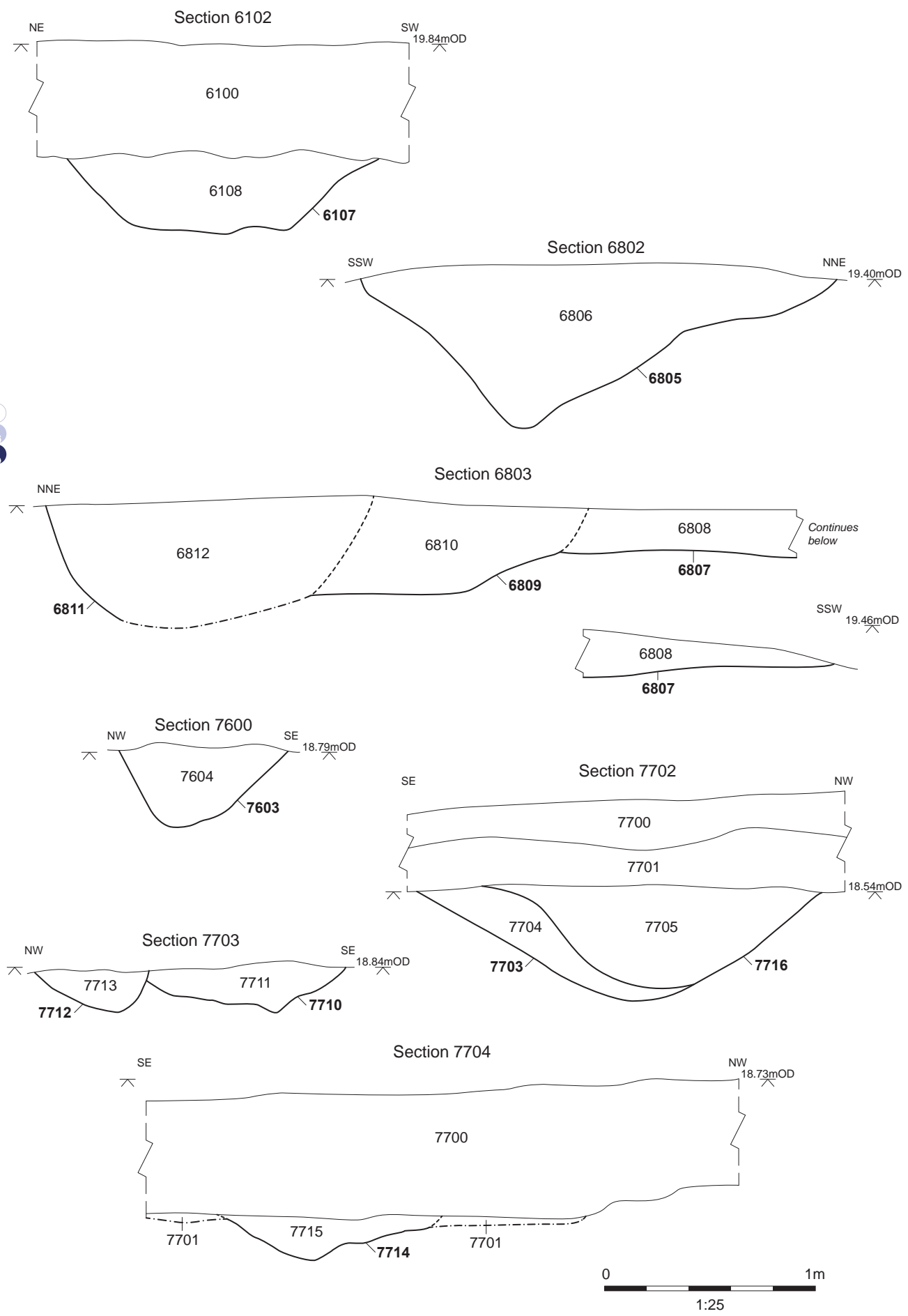
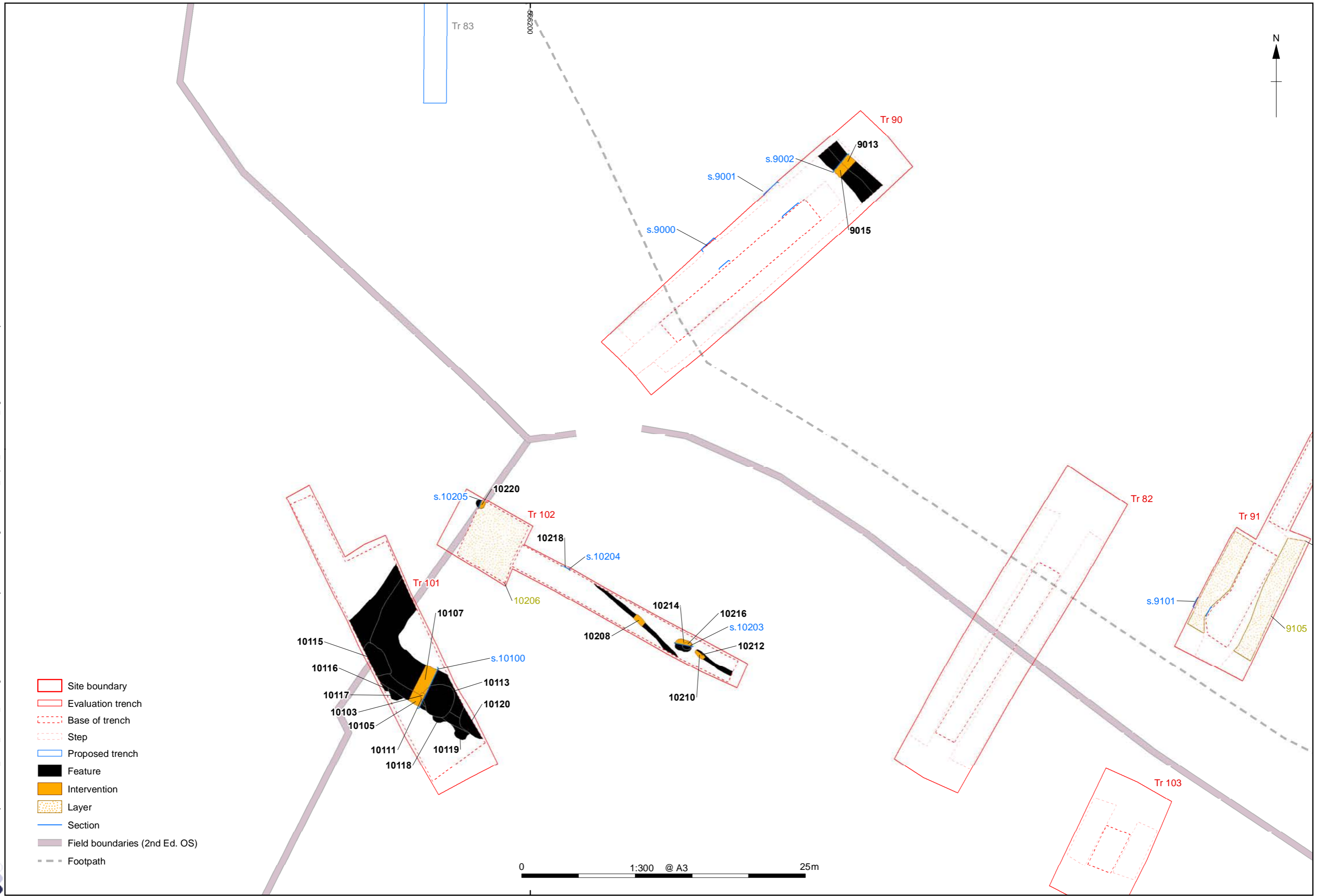

Figure 13: Sections 6102, 6802, 6803, 7702, 7703, 7704, 7600

\\10.0.10.86\Projects\Lower\_Thames\_Crossing\010\Geomatics\03 GIS Projects - LTC7L21\Figures\LTC7L21\_Report\_TrenchPlans\_Fig14.mxd\*caroline.souday\*26/01/2022



Contains Ordnance Survey data © Crown copyright and database right 2020, provided by client

Figure 14: Detailed plan of Trenches 82, 90 and 101-2

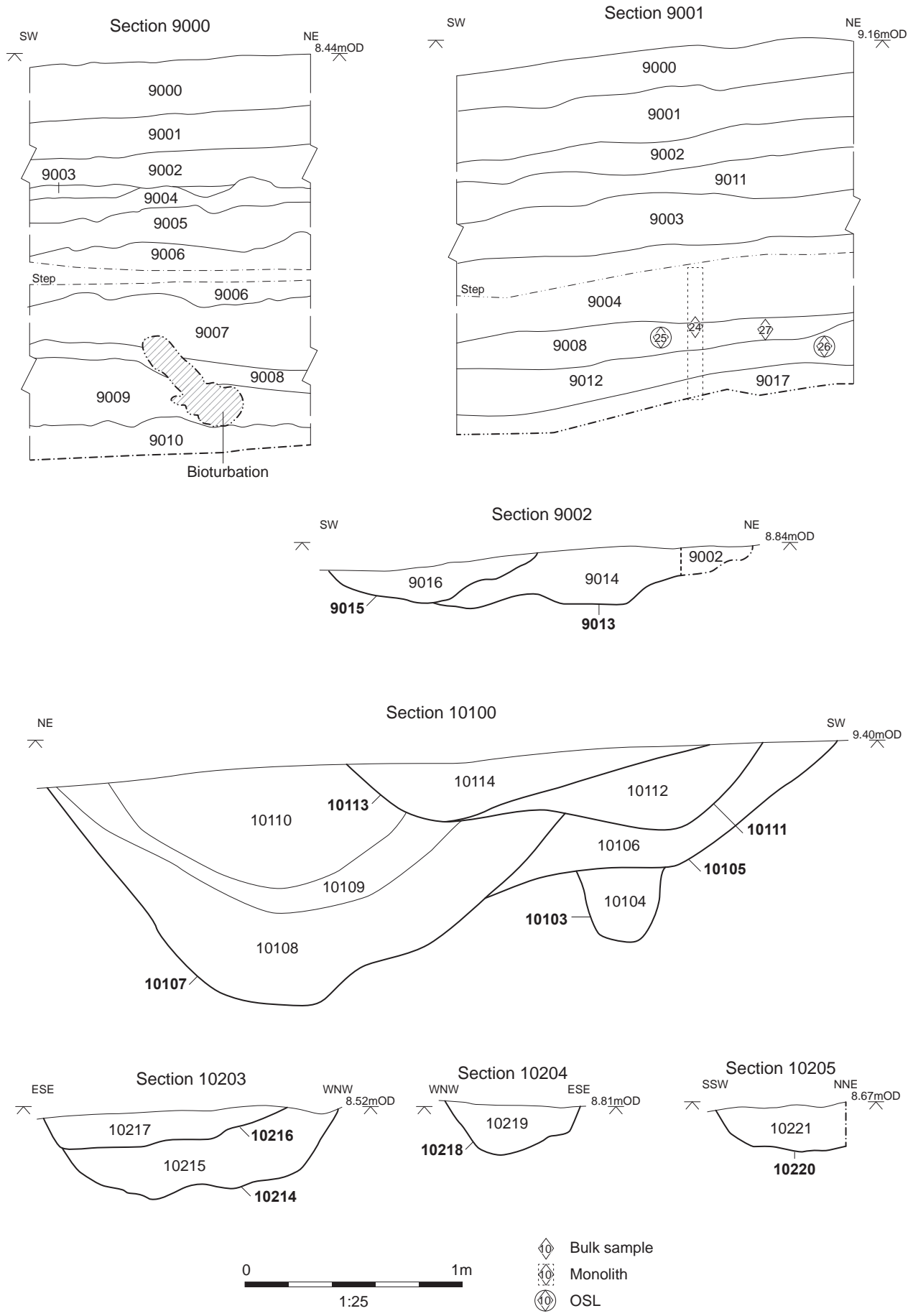
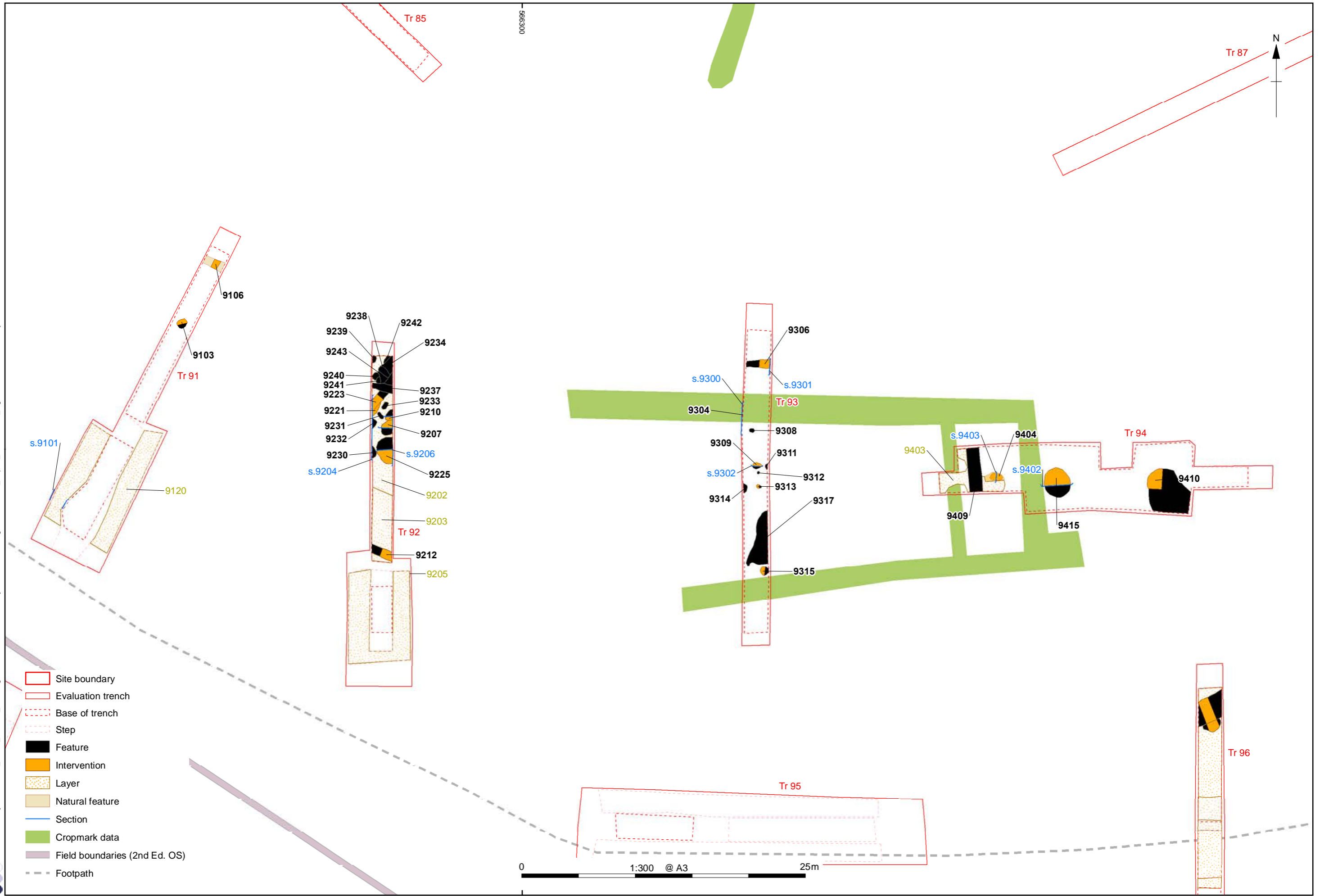

Figure 15: Sections 9000, 9001, 9002, 10100, 10203, 10204 and 10205

\\10.0.10.86\Projects\ILTCEV\_Lower\_Thames\_Crossing\010Geomatics\03 GIS Projects - L7\21\Figures\TC7L21\_Report\_TrenchPlans\_Fig16.mxd\*caroline.souday\*21/01/2022



Contains Ordnance Survey data © Crown copyright and database right 2020, provided by client

Figure 16: Detailed plan of Trenches 91-4

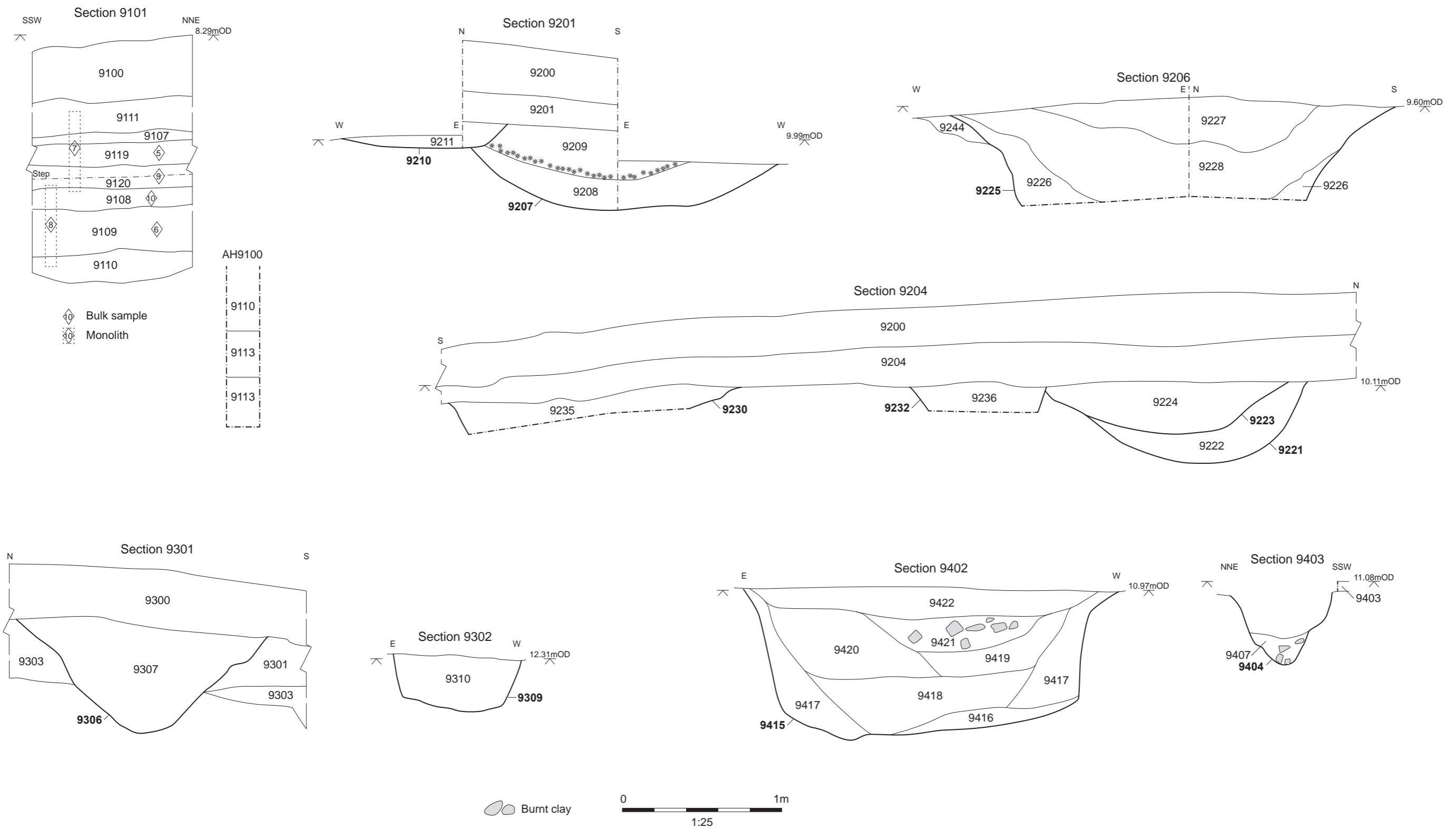
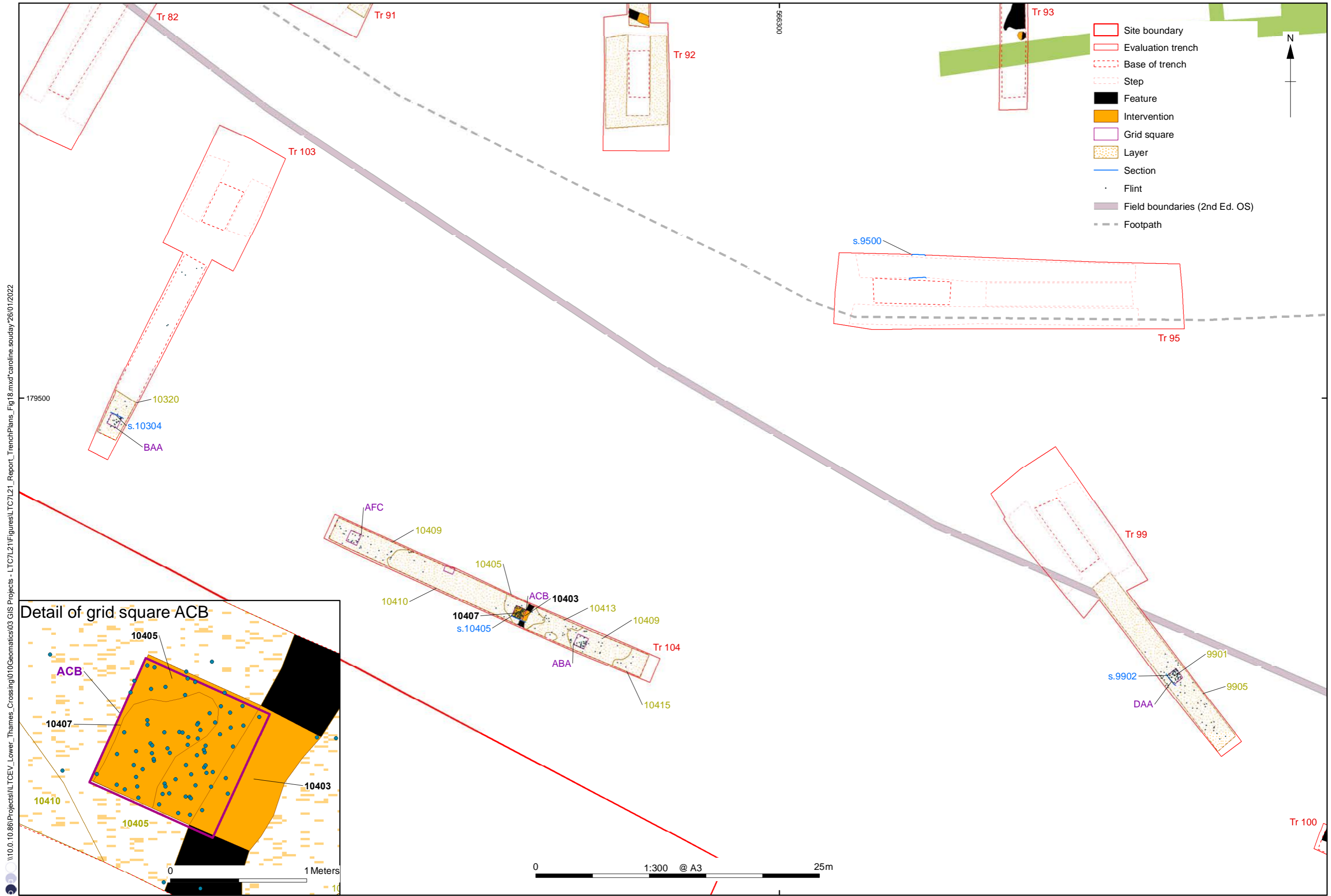

Figure 17: Sections 9101, 9201, 9204, 9206, 9301, 9302, 9402, 9403



\\10.0.10.86\Projects\ILTCEV\_Lower\_Themes\_Crossing\010Geomatics\03 GIS Projects - LTC7L21\Figures\LTC7L21\_Report\_TrenchPlans\_Fig18.mxd\*caroline.souday\*26/01/2022

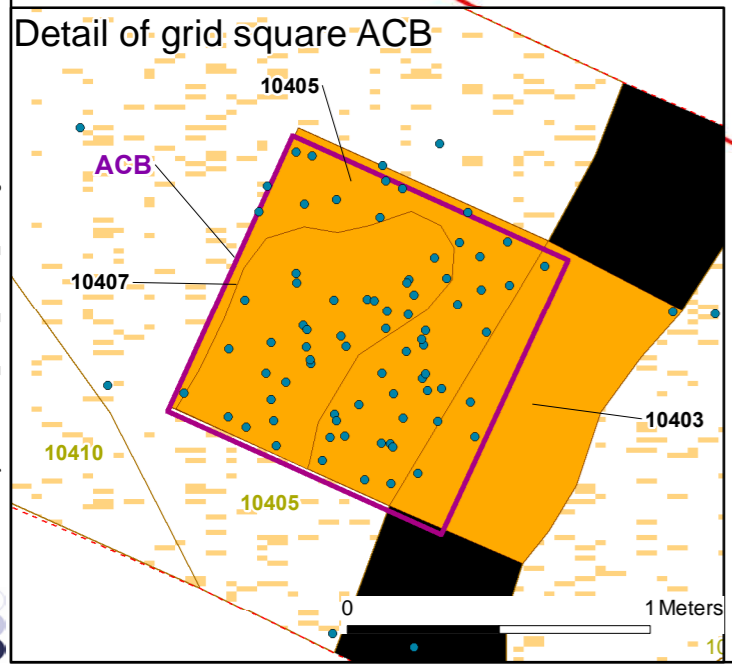

Figure 18: Detailed plan of Trenches 99, 103 and 104



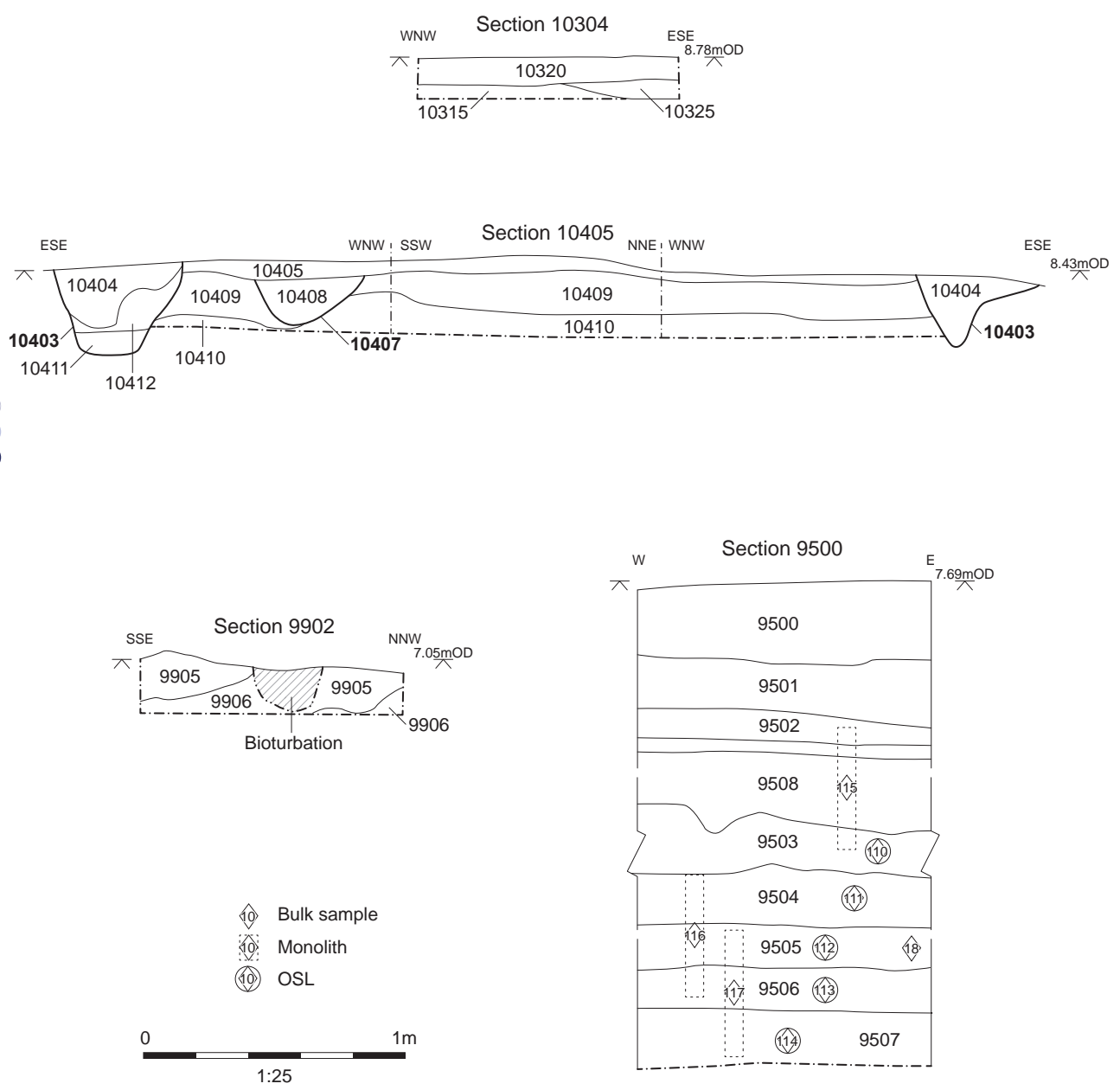
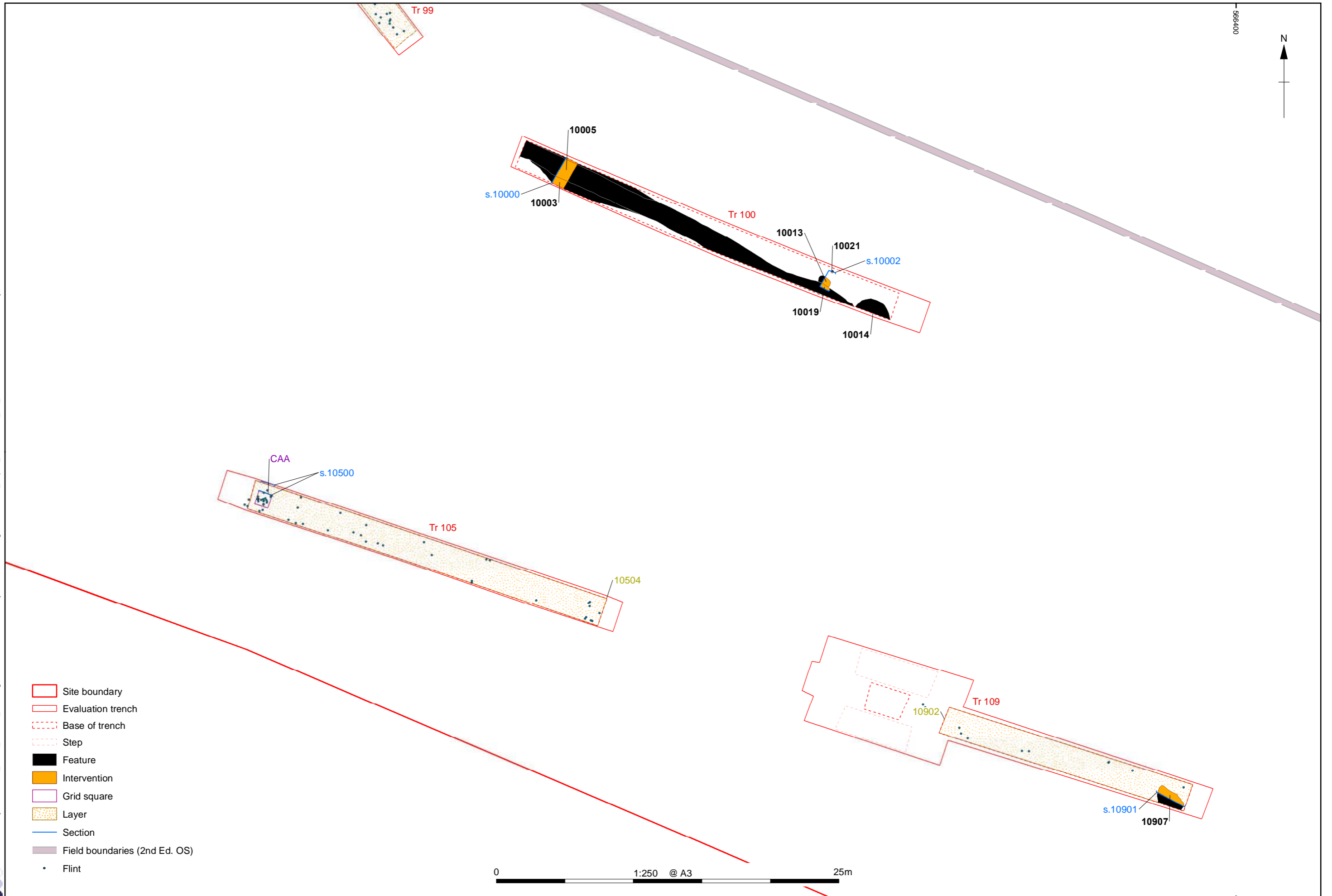

Figure 19: Sections 9902, 9500, 10304, 10405

\\10.0.10.86\Projects\ILTCEV\_Lower\_Themes\_Crossing\010Geomatics\03 GIS Projects - L\TC7L21\Figures\TC7L21\_Report\_TrenchPlans\_DD\_A3L211207.mxd\*caroline.souday\*26/01/2022



Contains Ordnance Survey data © Crown copyright and database right 2020, provided by client

Figure 20: Detailed plan of Trenches 100, 105 and 109

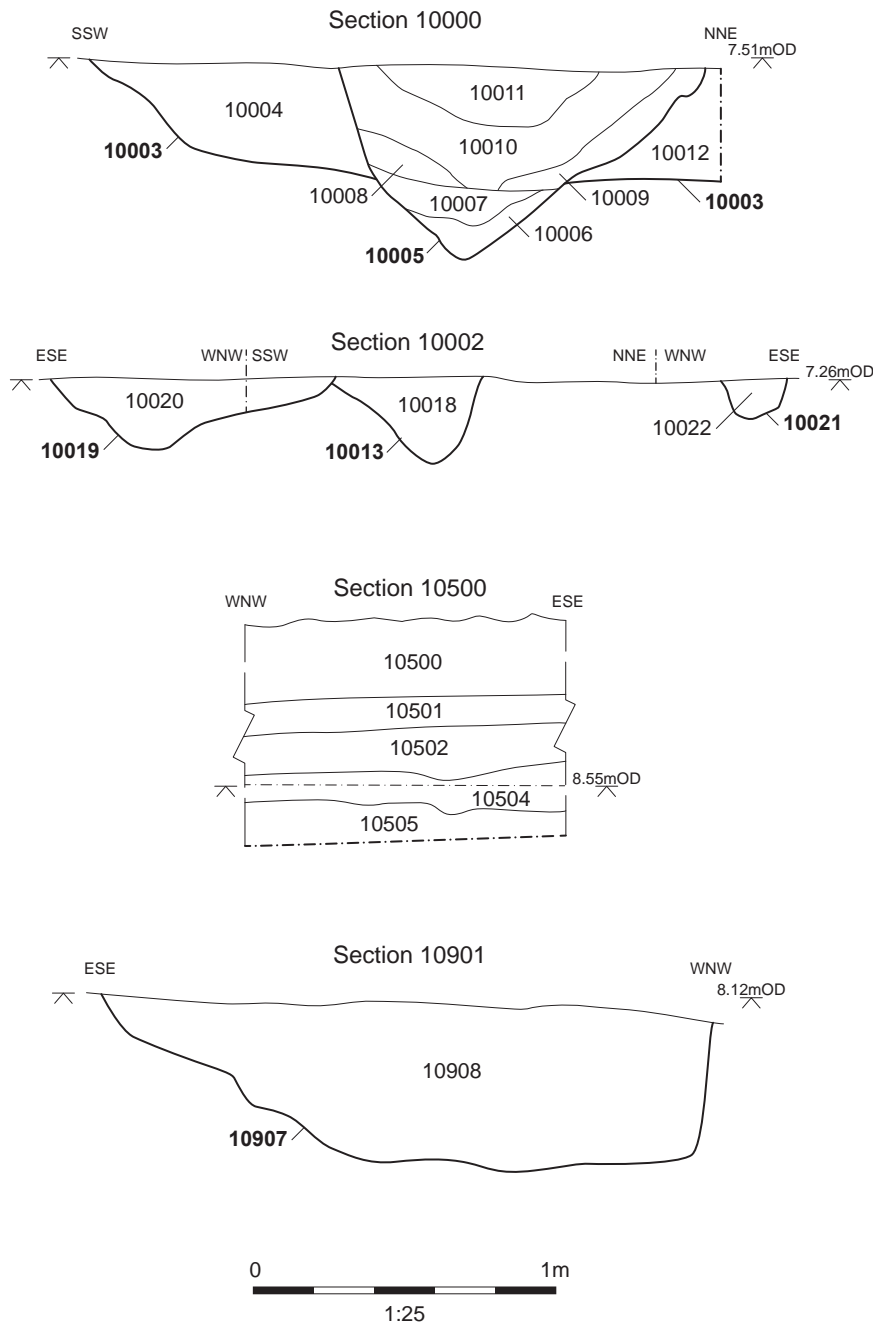
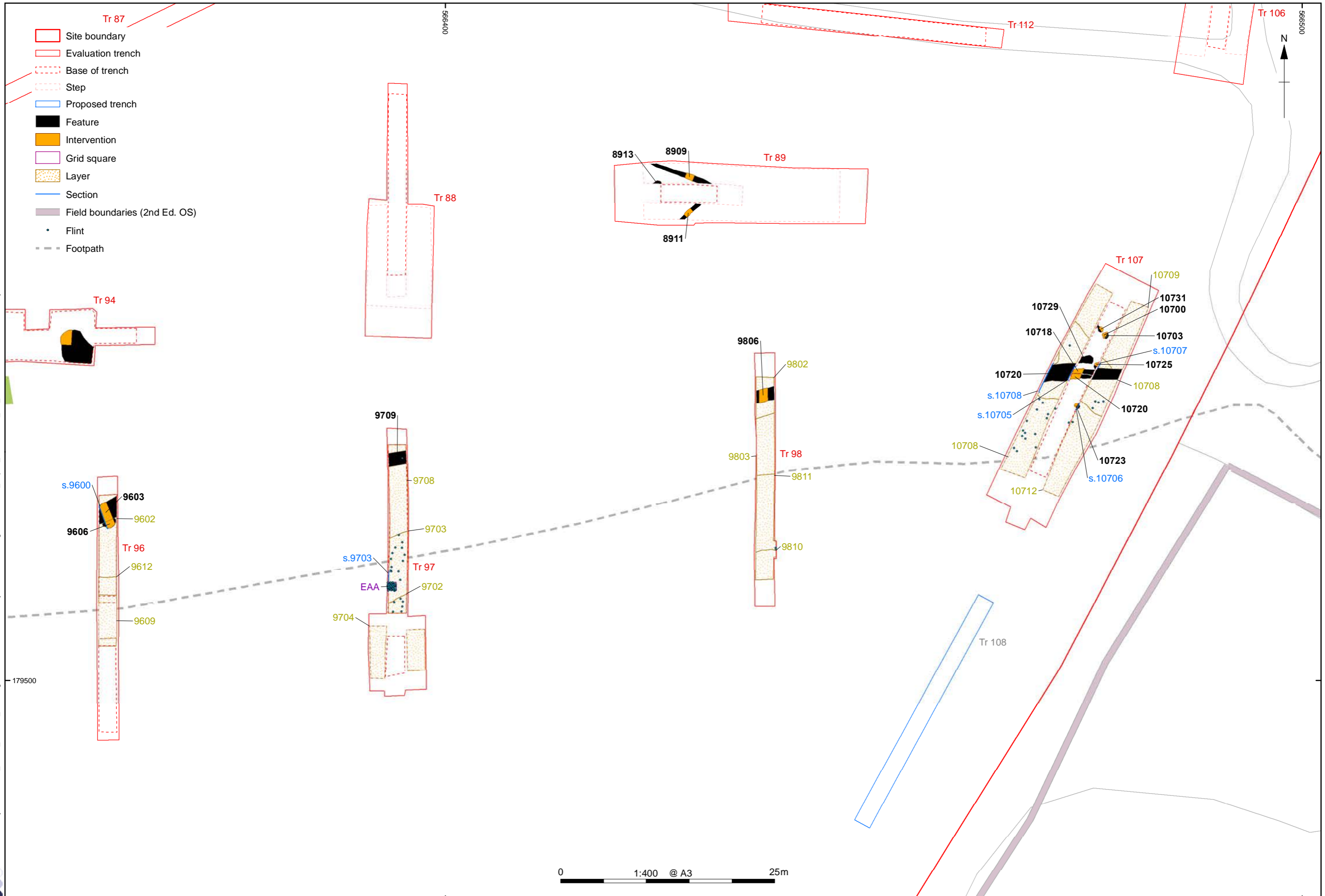

Figure 21: Sections 10000, 10002, 10500, 10901

\\10.0.10.86\Projects\ILTCEV\_Lower\_Thames\_Crossing\010Geomatics\03 GIS Projects - L7\7L21\Figures\TC7L21\_Report\_TrenchPlans\_DD\_A3L21207.mxd\*caroline.souday\*26/01/2022



Contains Ordnance Survey data © Crown copyright and database right 2020, provided by client

Figure 22: Detailed plan of Trenches 89, 96-8 and 107

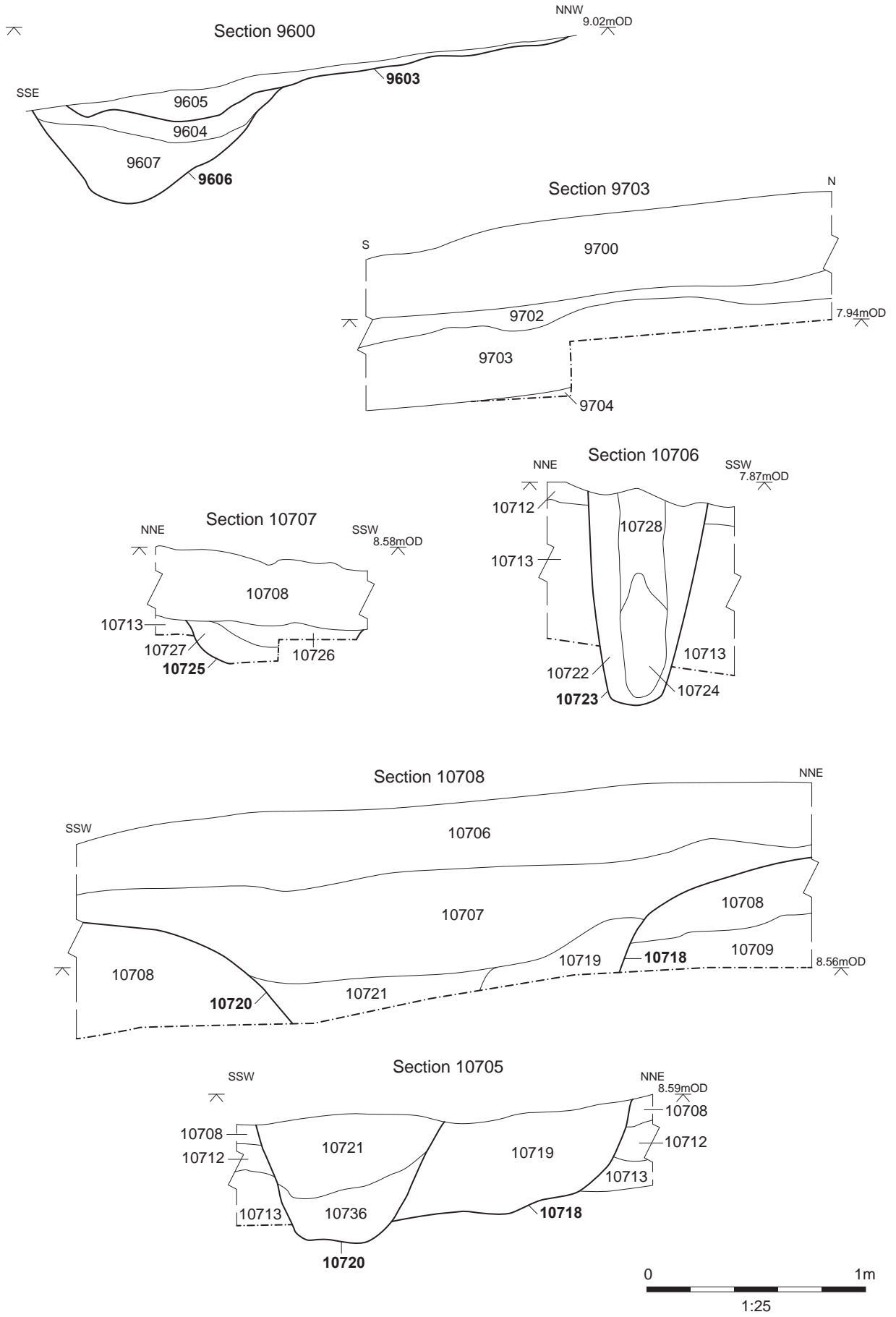
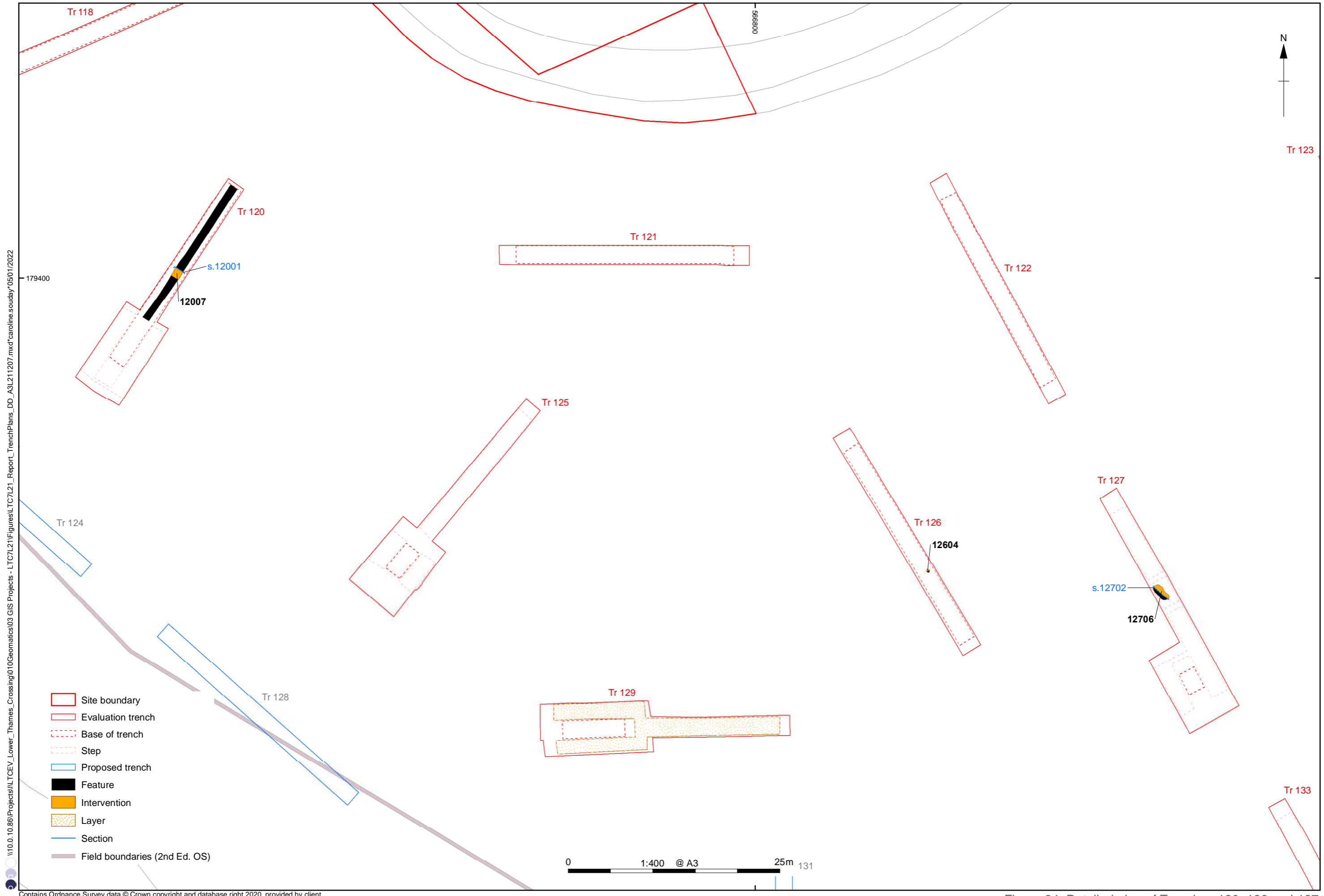

Figure 23: Sections 9600, 9703, 10706, 10707, 10705/10708



\\10.0.10.86\Projects\ILTCEV\_Lower\_Themes\_Crossing\010Geomatics\03 GIS Projects - L\TC7\21\Figures\TC7\21\_Report\_TrenchPlans\_DD\_A3\211207.mxd\*caroline.souday\*05/01/2022

Contains Ordnance Survey data © Crown copyright and database right 2020, provided by client

Figure 24: Detailed plan of Trenches 120, 126 and 127

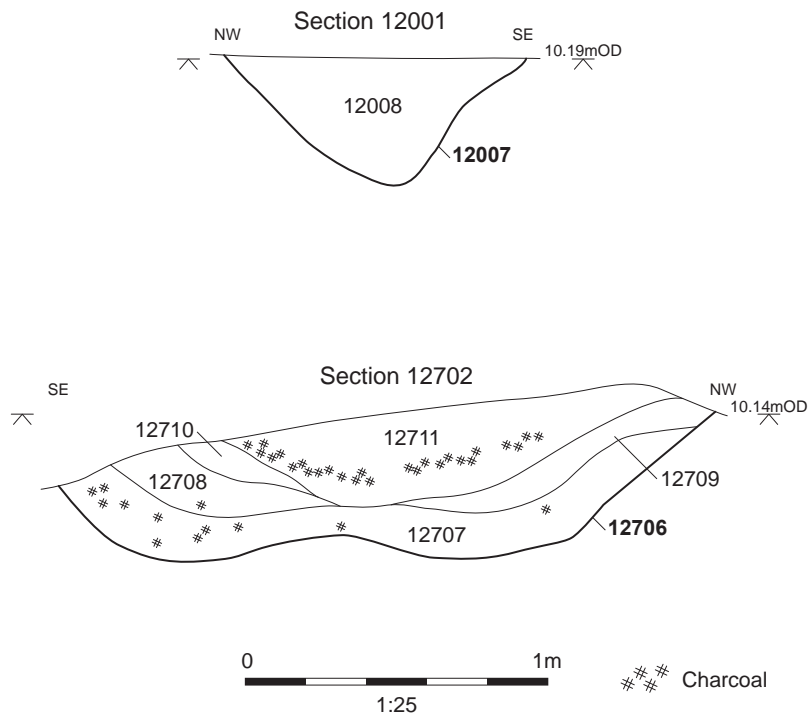
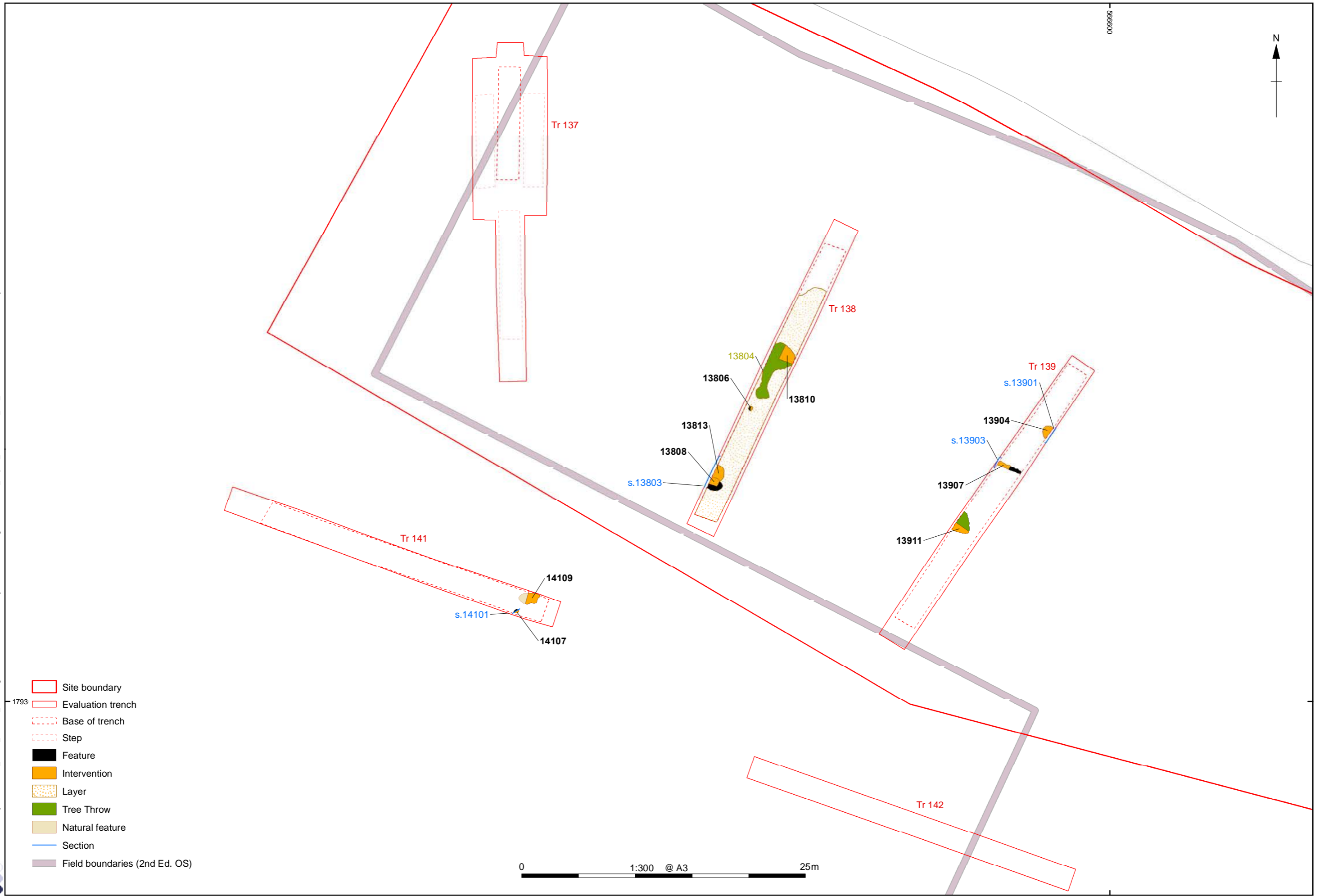

Figure 25: Sections 12001, 12702

\\10.0.10.86\Projects\IL TCEV\_Lower\_Thames\_Crossing\010\Geomatics\03 GIS Projects - LTC7L21\Figures\LTC7L21\_Report\_TrenchPlans\_DD\_A3L211207.mxd\*caroline.souday\*26/01/2022



- Site boundary
- Evaluation trench
- Base of trench
- Step
- Feature
- Intervention
- Layer
- Tree Throw
- Natural feature
- Section
- Field boundaries (2nd Ed. OS)

1793

Contains Ordnance Survey data © Crown copyright and database right 2020, provided by client

Figure 26: Detailed plan of Trenches 138, 139 and 141



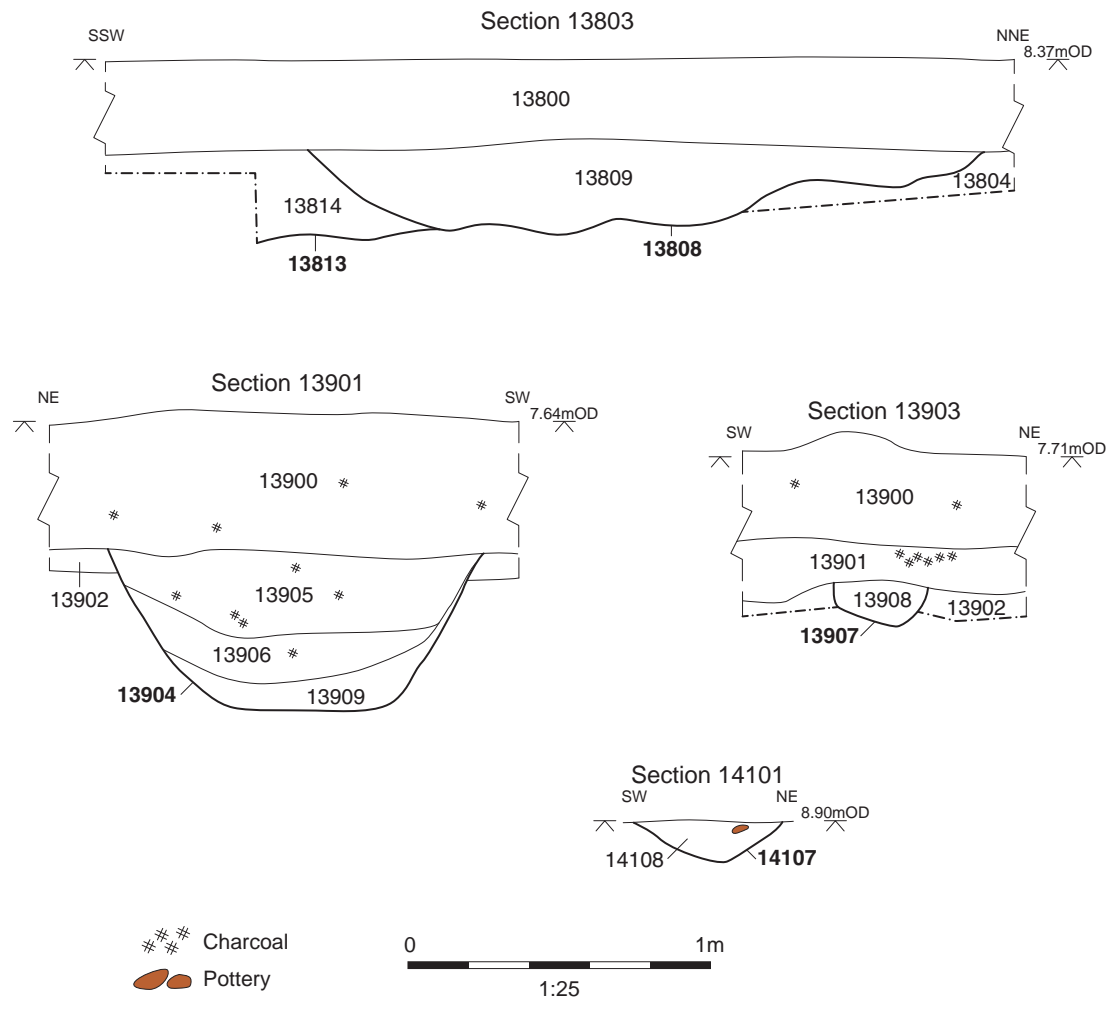
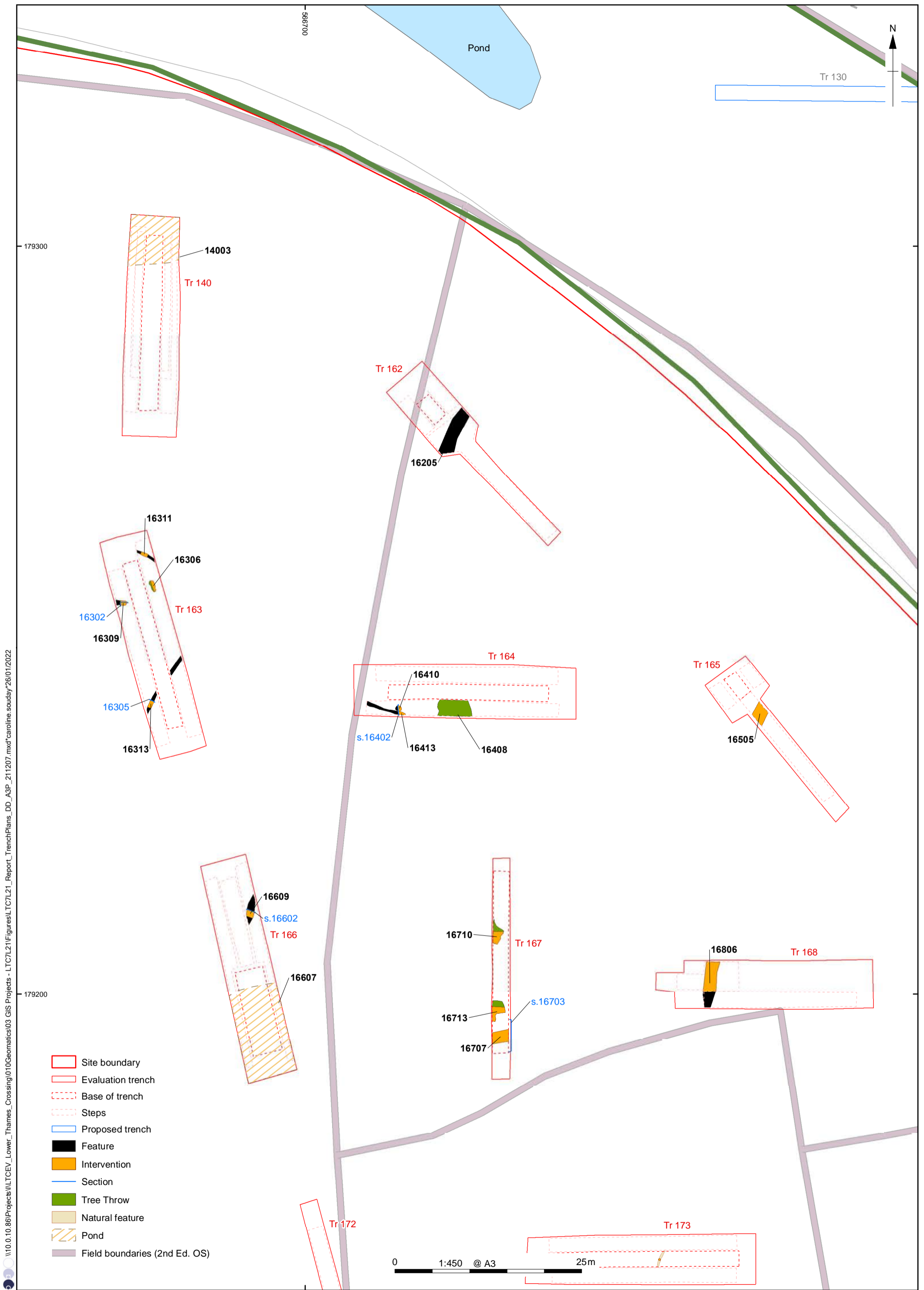

Figure 27: Sections 13803, 13901, 13903, 14101



Contains Ordnance Survey data © Crown copyright and database right 2020, provided by client

Figure 28: Detailed plan of Trenches 140 and 162-8

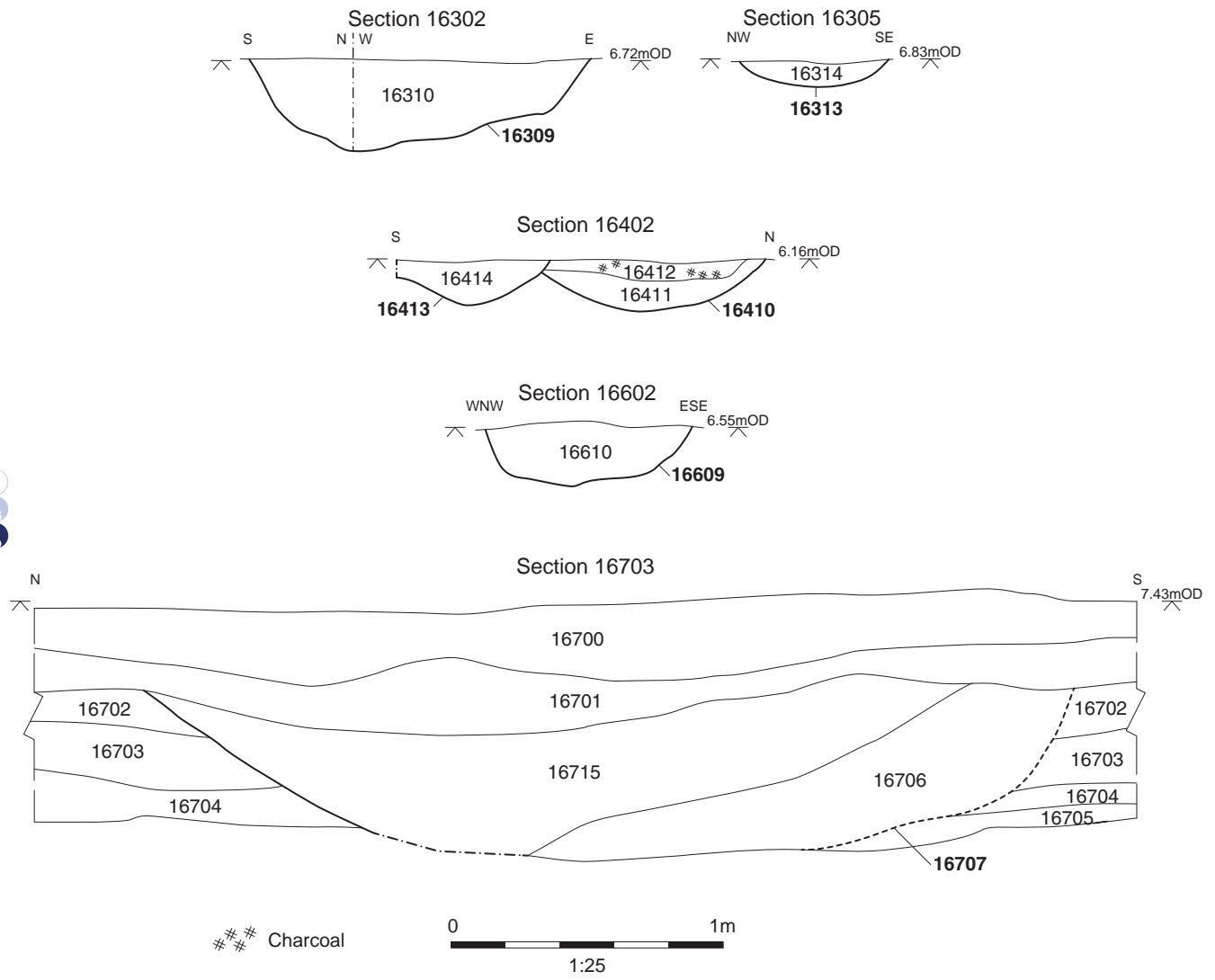

Figure 29: Sections 16302, 16305, 16402, 16602, 16703

\\10.0.10.86\Projects\Lower\_Thames\_Crossing\010\Geomatics\GIS\Projects - L107L21\Figures\L107L21\_Report\_TrenchPlans\_Fig30.mxd\*caroline.souday\*26/01/2022

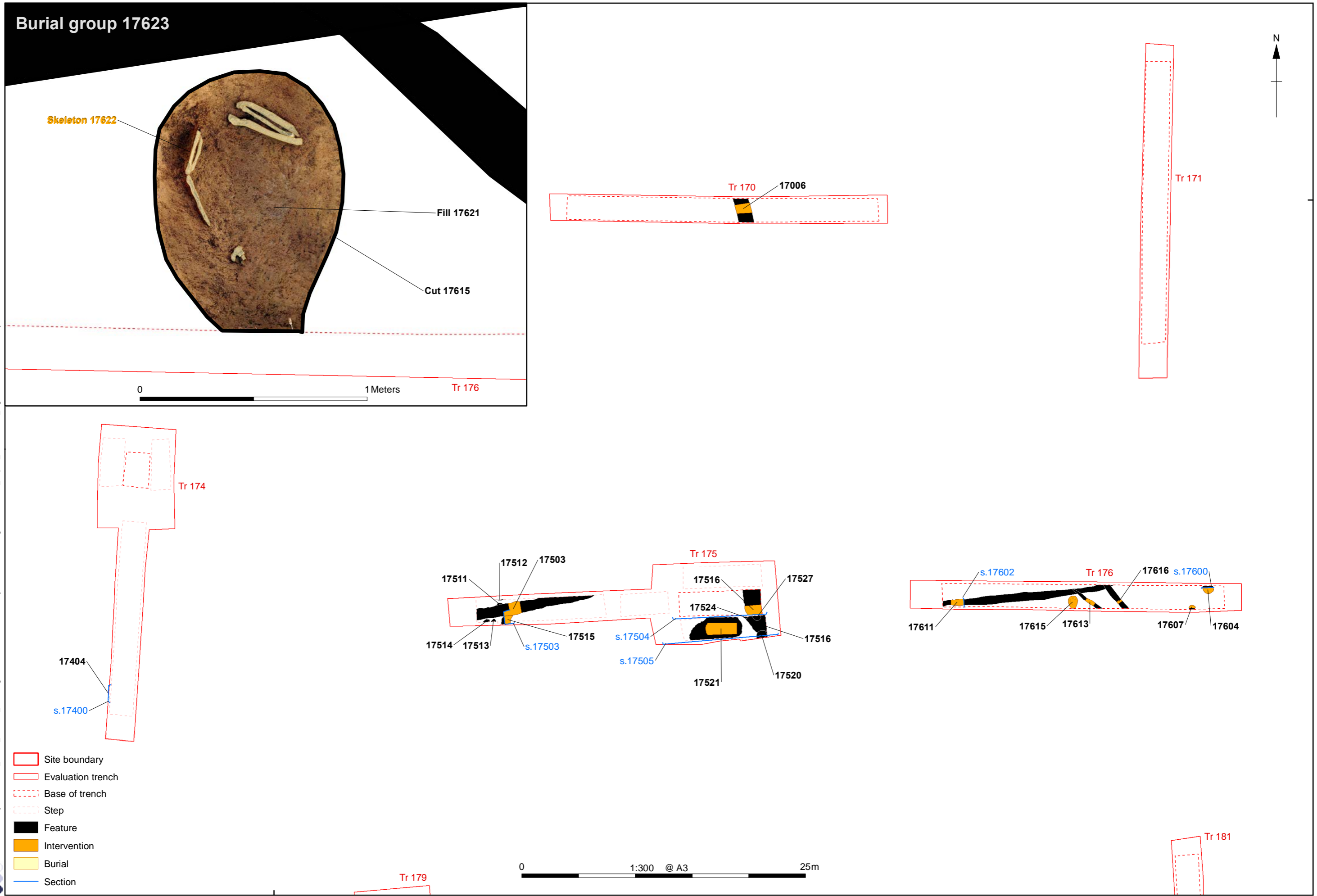

Figure 30: Detailed plan of Trenches 170 and 174-6

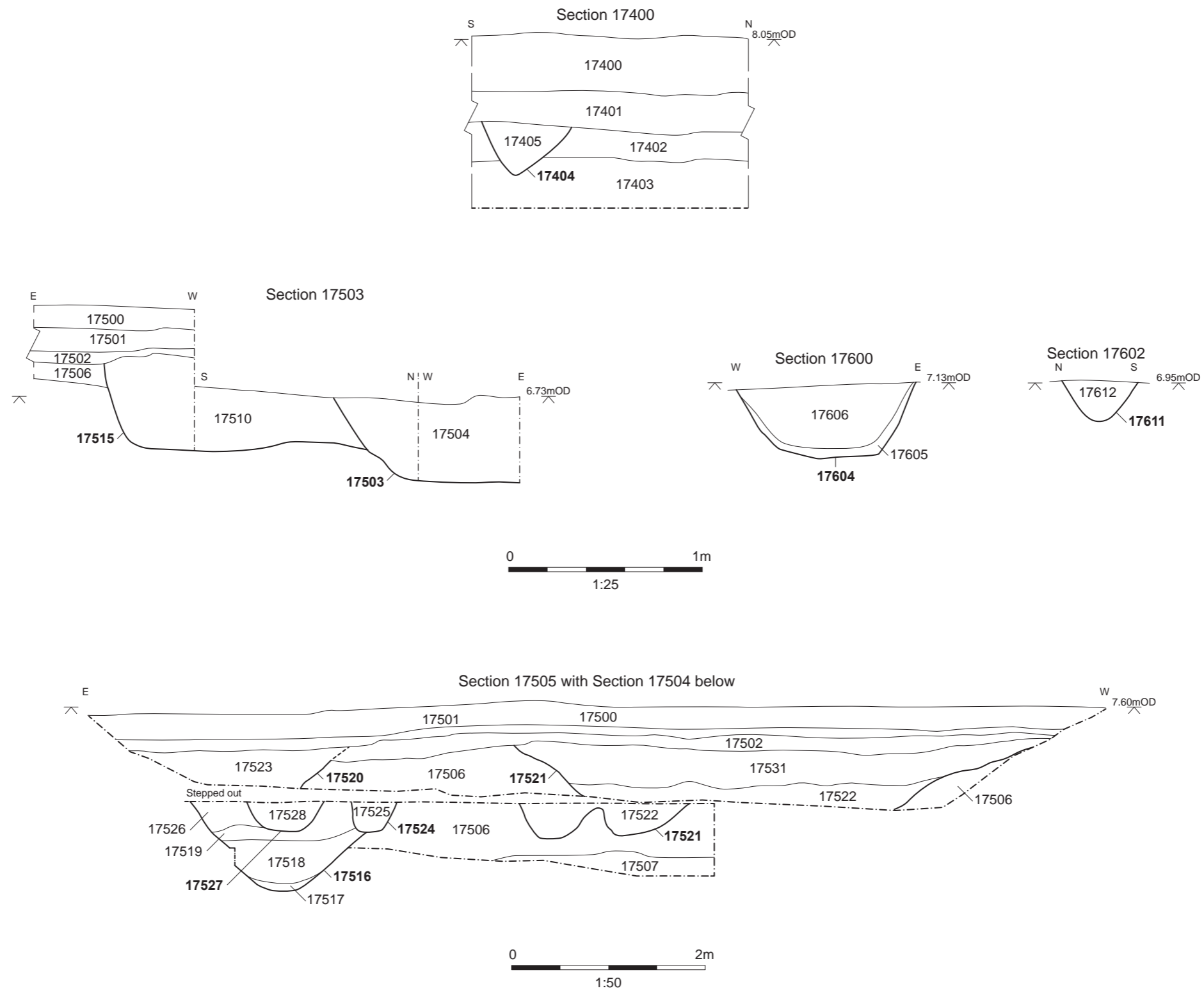

Figure 31: Sections 17400, 17503, 17504, 17505, 17600, 17602

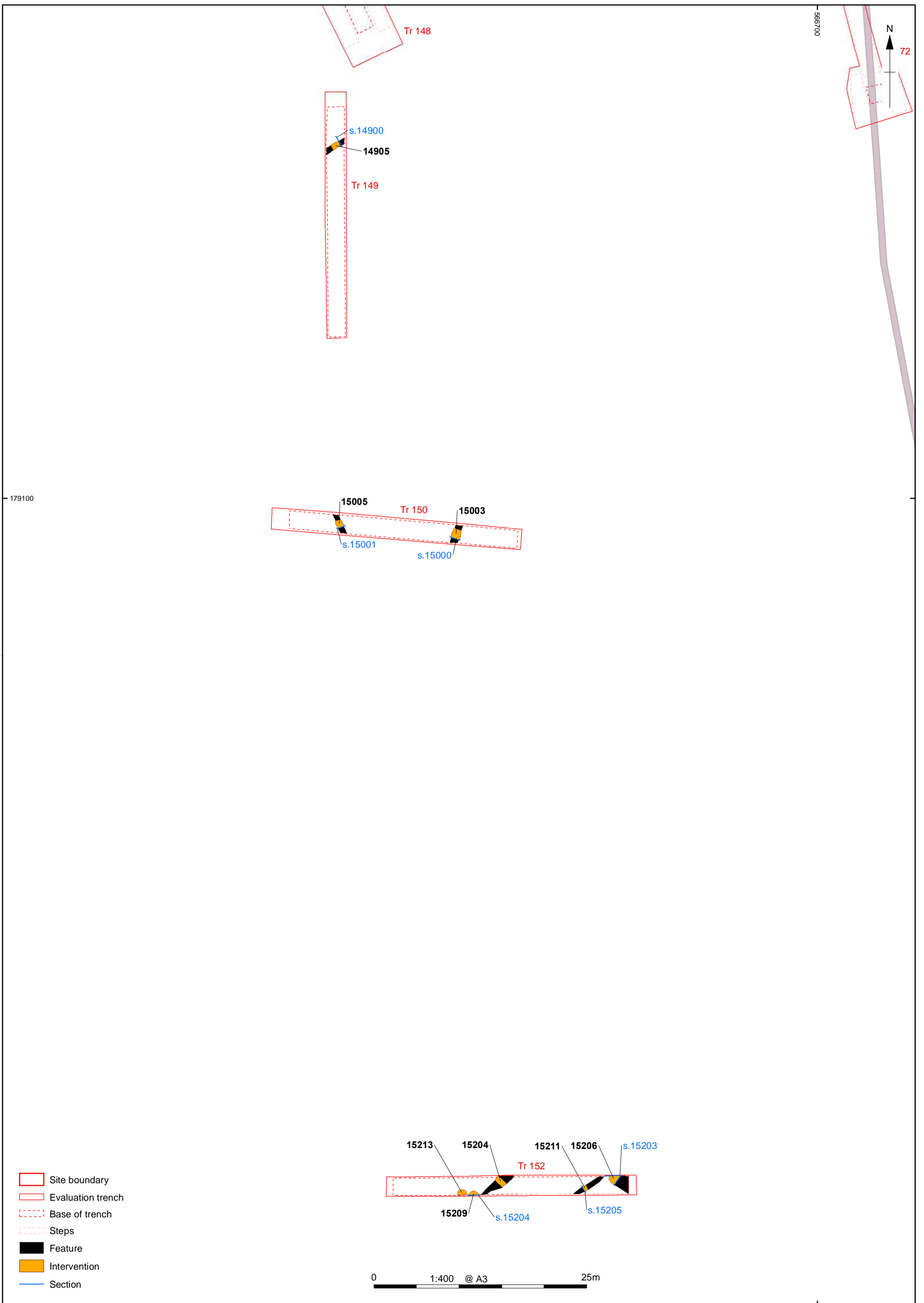

Figure 32: Detailed plan of Trenches 149, 150 and 152

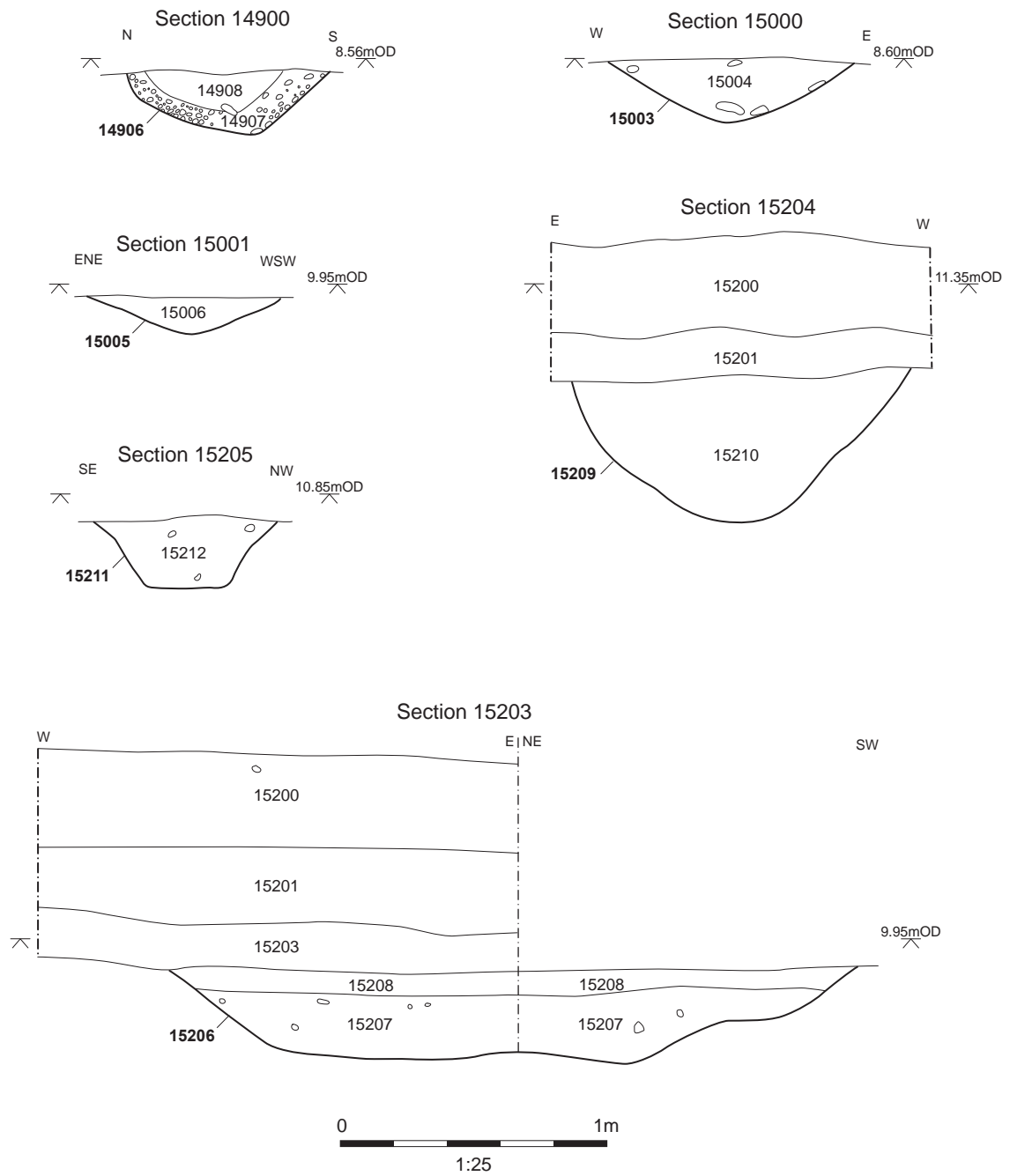

Figure 33: Sections 14900, 15000, 15001, 15203, 15204, 15205

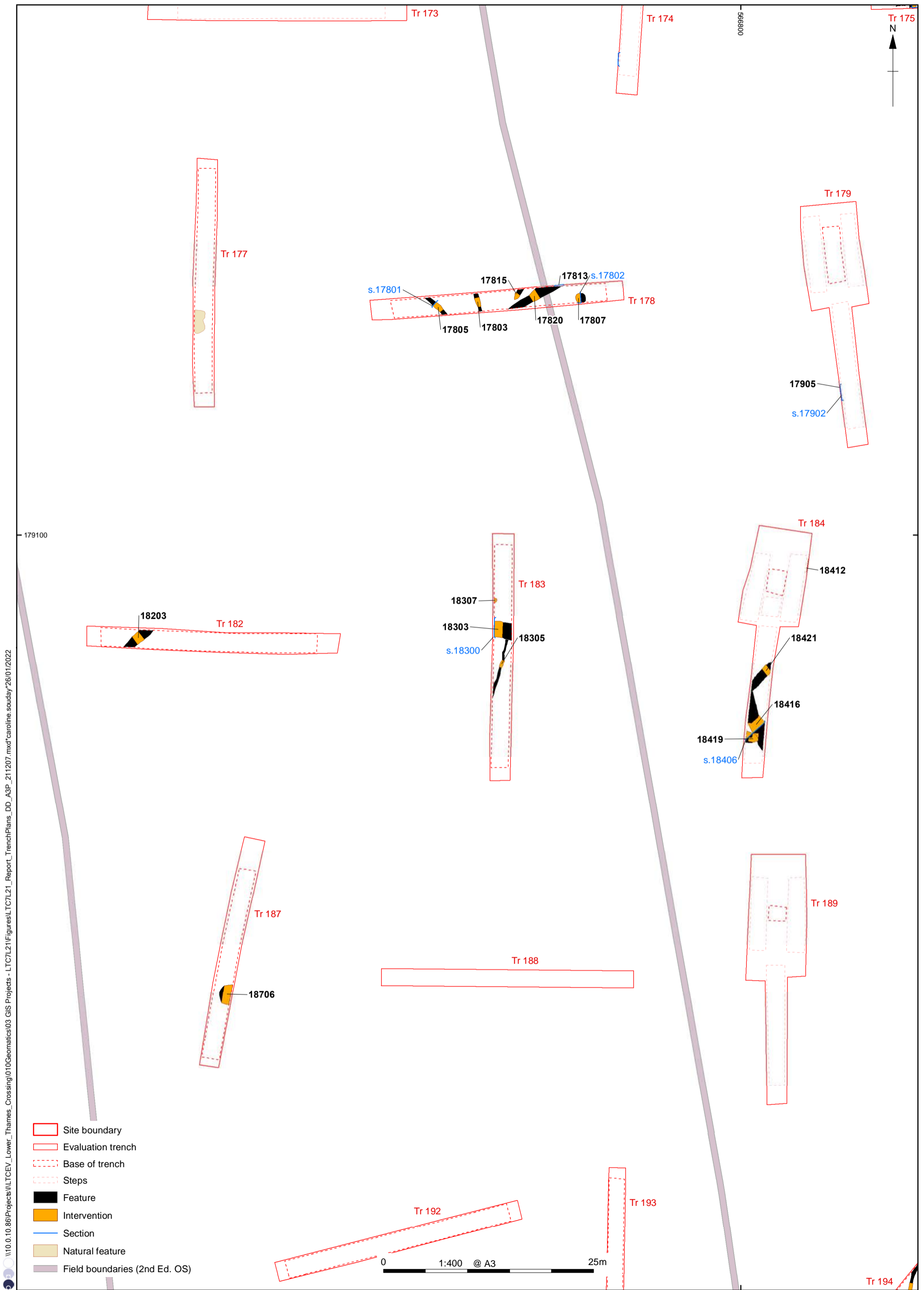

Figure 34: Detailed plan of Trenches 178-9, 182-4 and 187



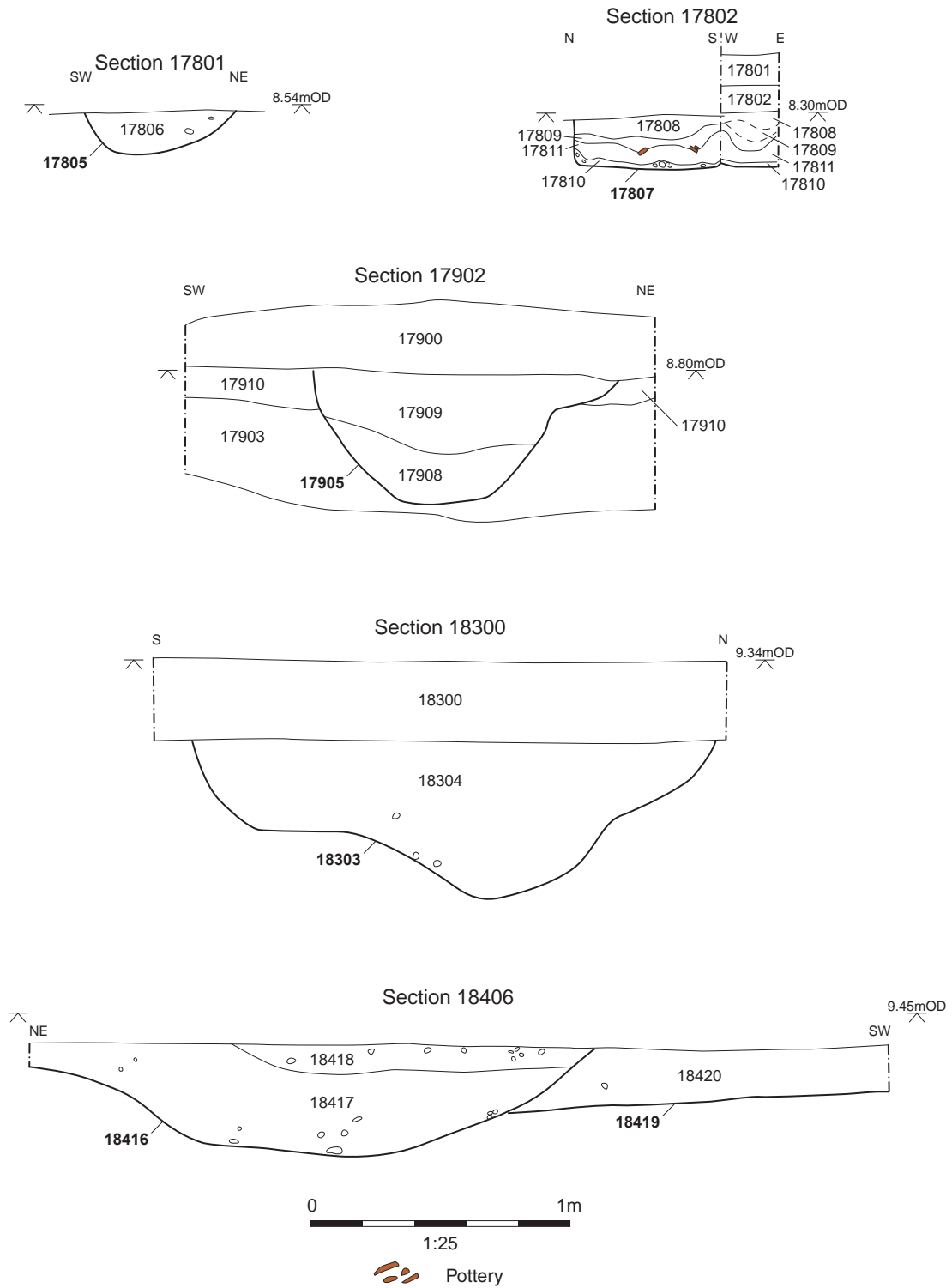
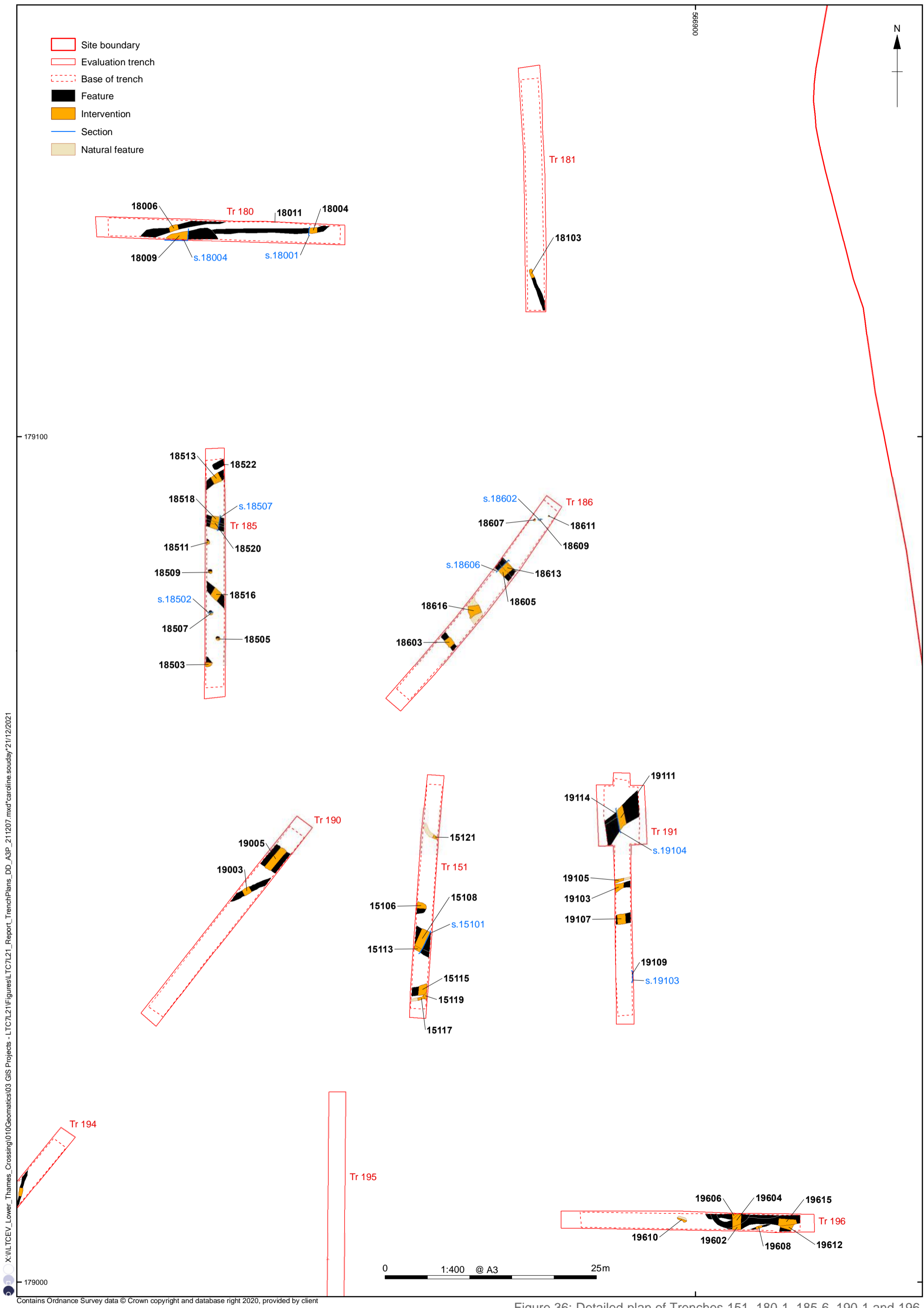

Figure 35: Sections 17801, 17802, 17902, 18300, 18406



X:\ILTCEV\_Lower\_Thames\_Crossing\010\Geomatics\03 GIS Projects - L\TC7L2\1\Figures\TC7L2\_1\_Report\_TrenchPlans\_DD\_A3P\_211207.mxd\*caroline.souday\*21/12/2021

Contains Ordnance Survey data © Crown copyright and database right 2020, provided by client

Figure 36: Detailed plan of Trenches 151, 180-1, 185-6, 190-1 and 196

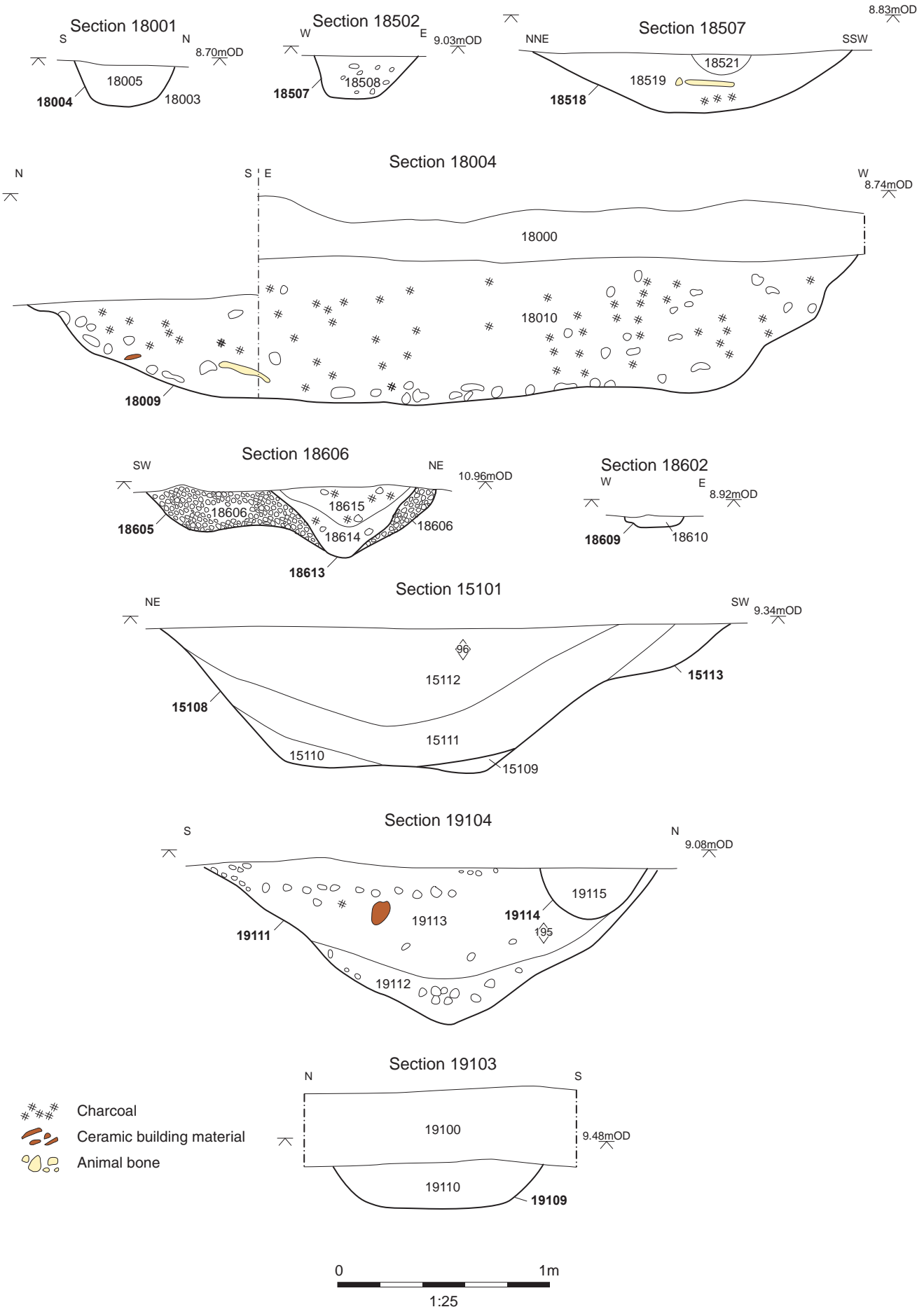
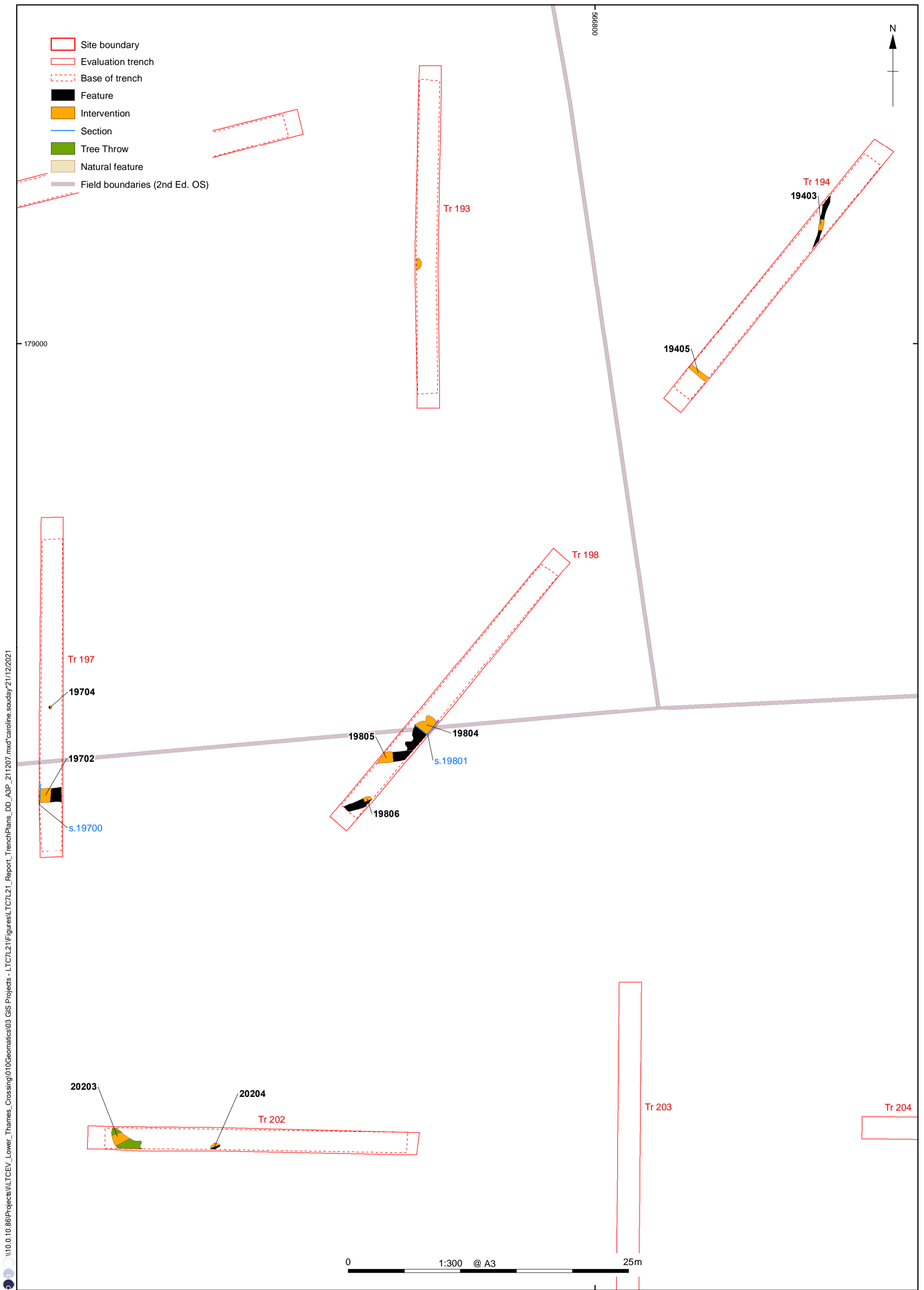

Figure 37: Sections 15101, 18001, 18004, 18502, 18507, 18602, 18606, 19103, 19104



I:\10.0.10.86\Projects\Lower\_Thames\_Crossing\010\Geomatics\03 GIS Projects - LTC7L2\Figures\LTC7L21\_Report\_TrenchPlans\_DD\_A3P\_211207.mxd\*caroline.souday\*21/12/2021

Contains Ordnance Survey data © Crown copyright and database right 2020, provided by client

Figure 38: Detailed plan of Trenches 194, 197-8 and 202

X:\ILTCEV\_Lower\_Thames\_Crossing\010Geomatics\03 GIS Projects - L\TC7L21\Figures\TC7L21\_Report\_TrenchPlans\_DD\_A3L21207.mxd\*caroline.souday\*21/12/2021

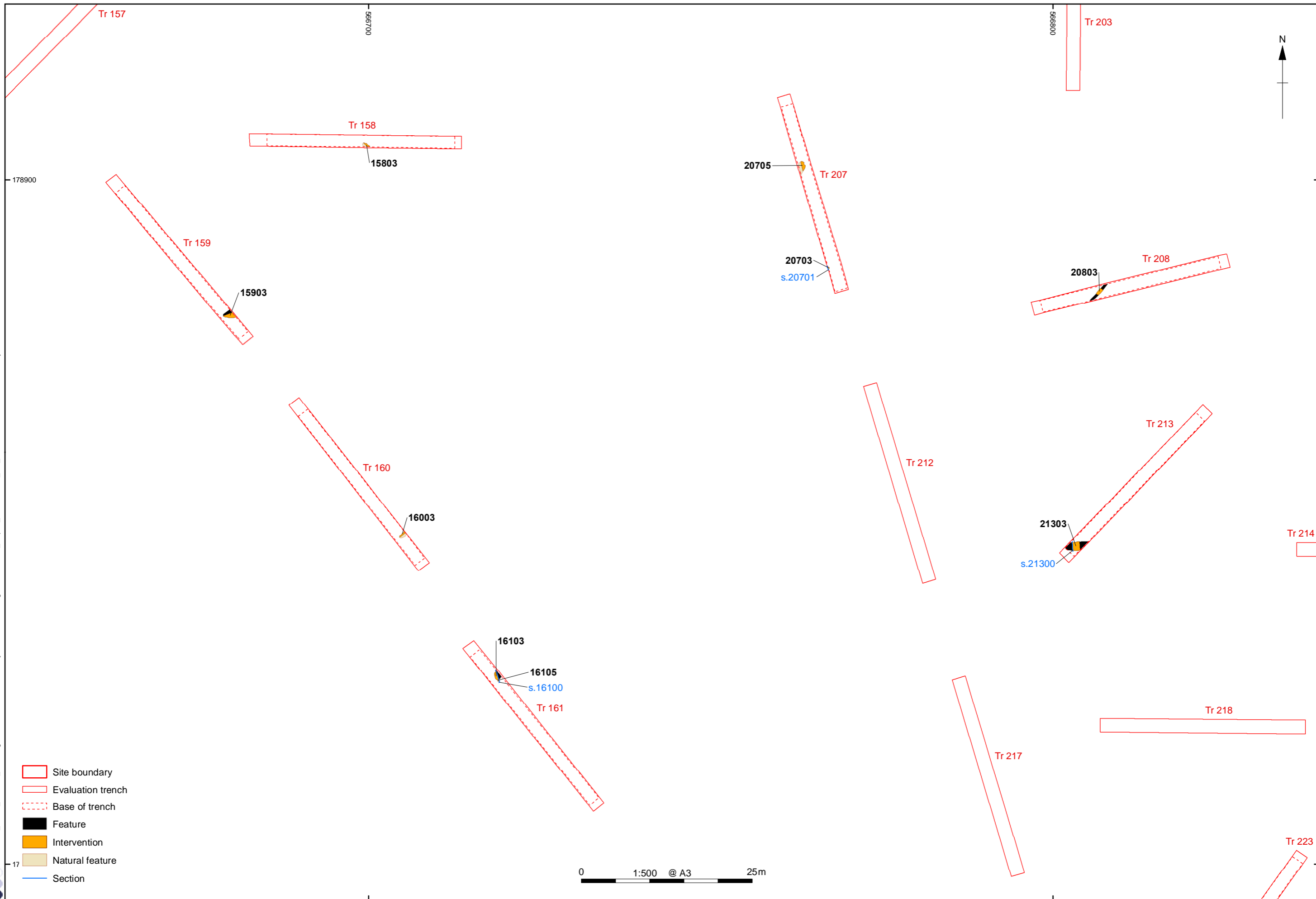

Contains Ordnance Survey data © Crown copyright and database right 2020, provided by client

Figure 39: Detailed plan of Trenches 159, 161, 207-8 and 213

\\10.0.10.86\Projects\ILTCEV\_Lower\_Thames\_Crossing\010Geomatics\03 GIS Projects - LTCT7L21\Figures\LTCT7L21\_Report\_TrenchPlans\_DD\_A3L21207.mxd\*caroline.souday\05/01/2022

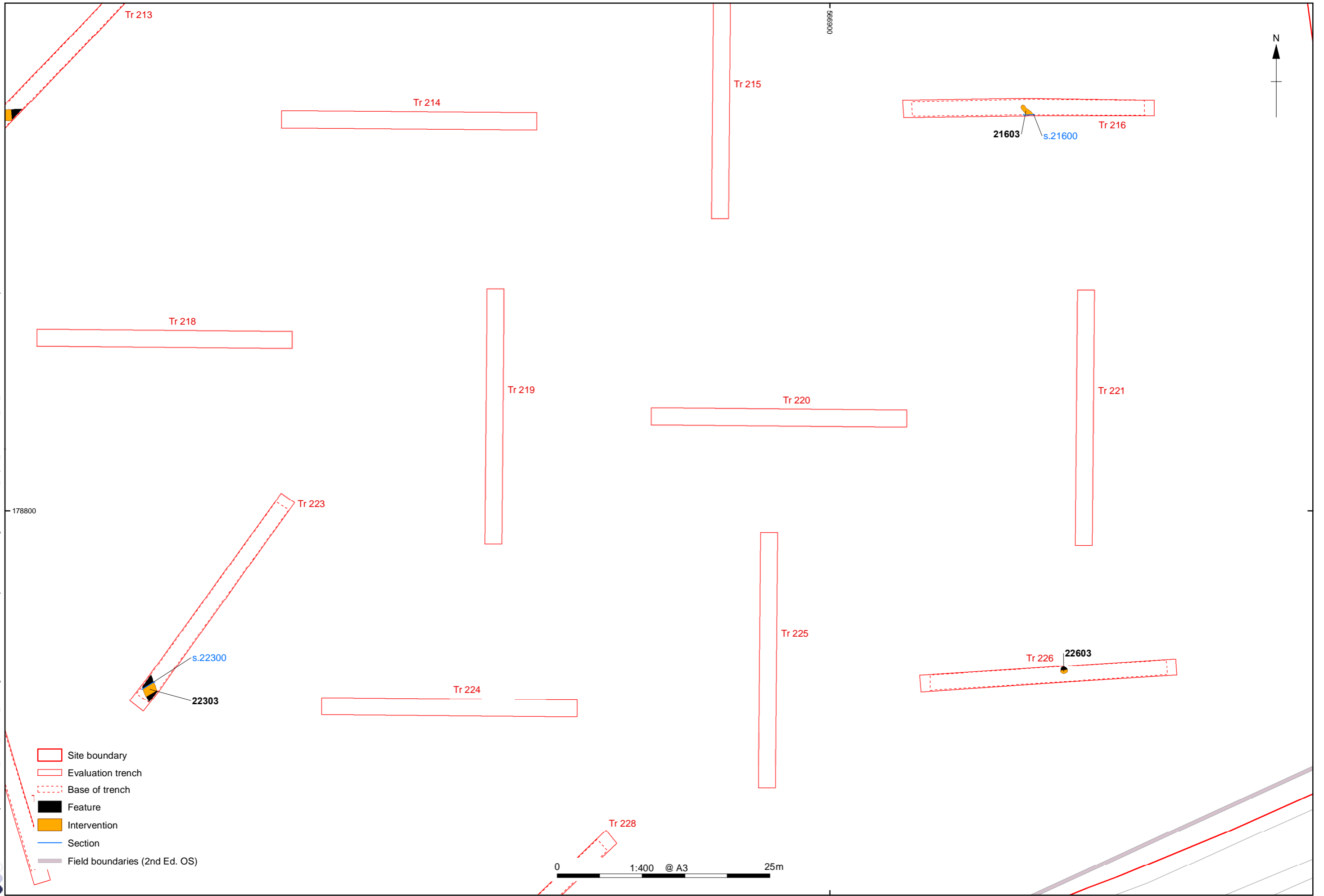

- Site boundary
- Evaluation trench
- Base of trench
- Feature
- Intervention
- Section
- Field boundaries (2nd Ed. OS)

Contains Ordnance Survey data © Crown copyright and database right 2020, provided by client

Figure 40: Detailed plan of Trenches 216, 223 and 226

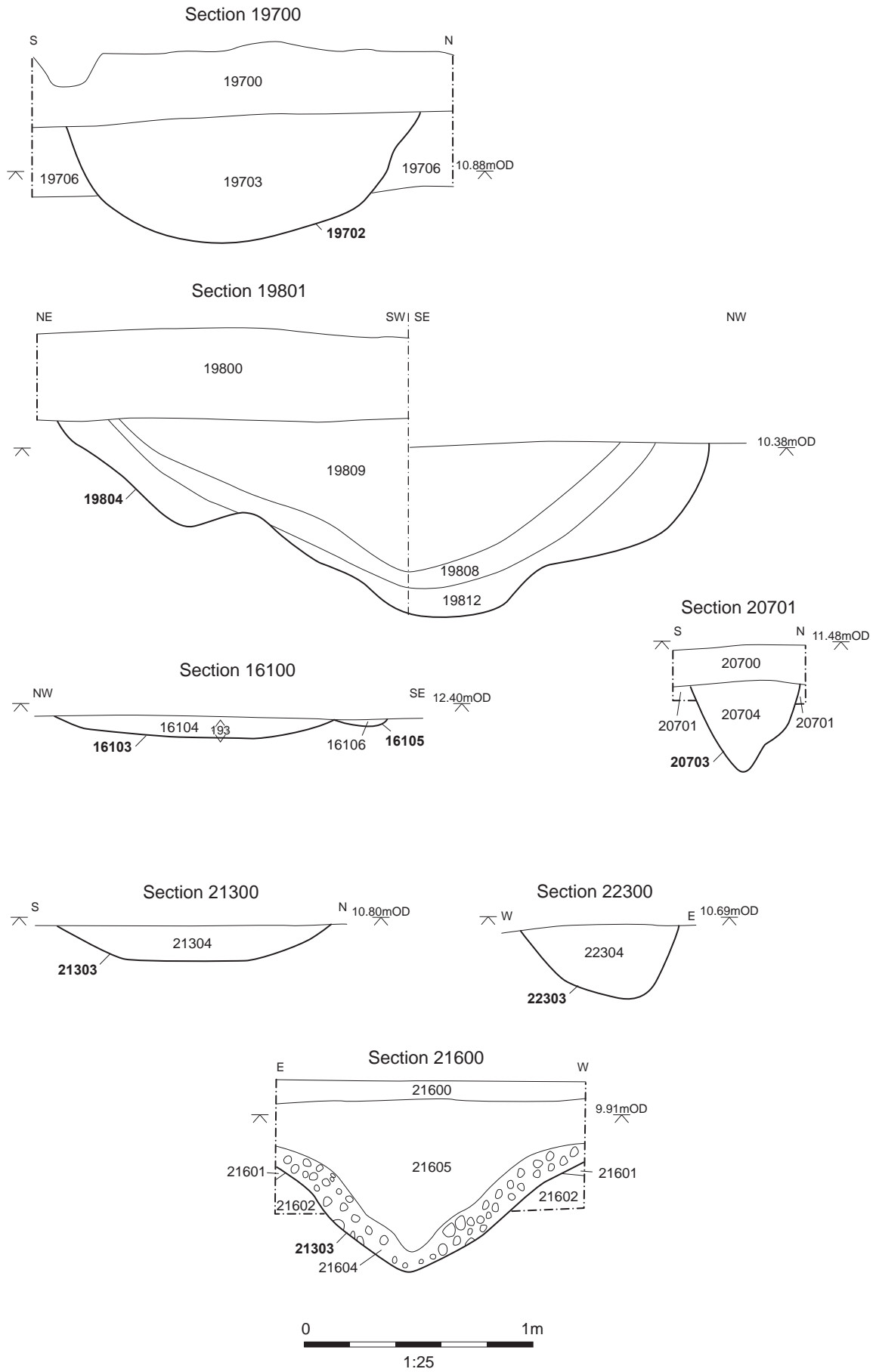
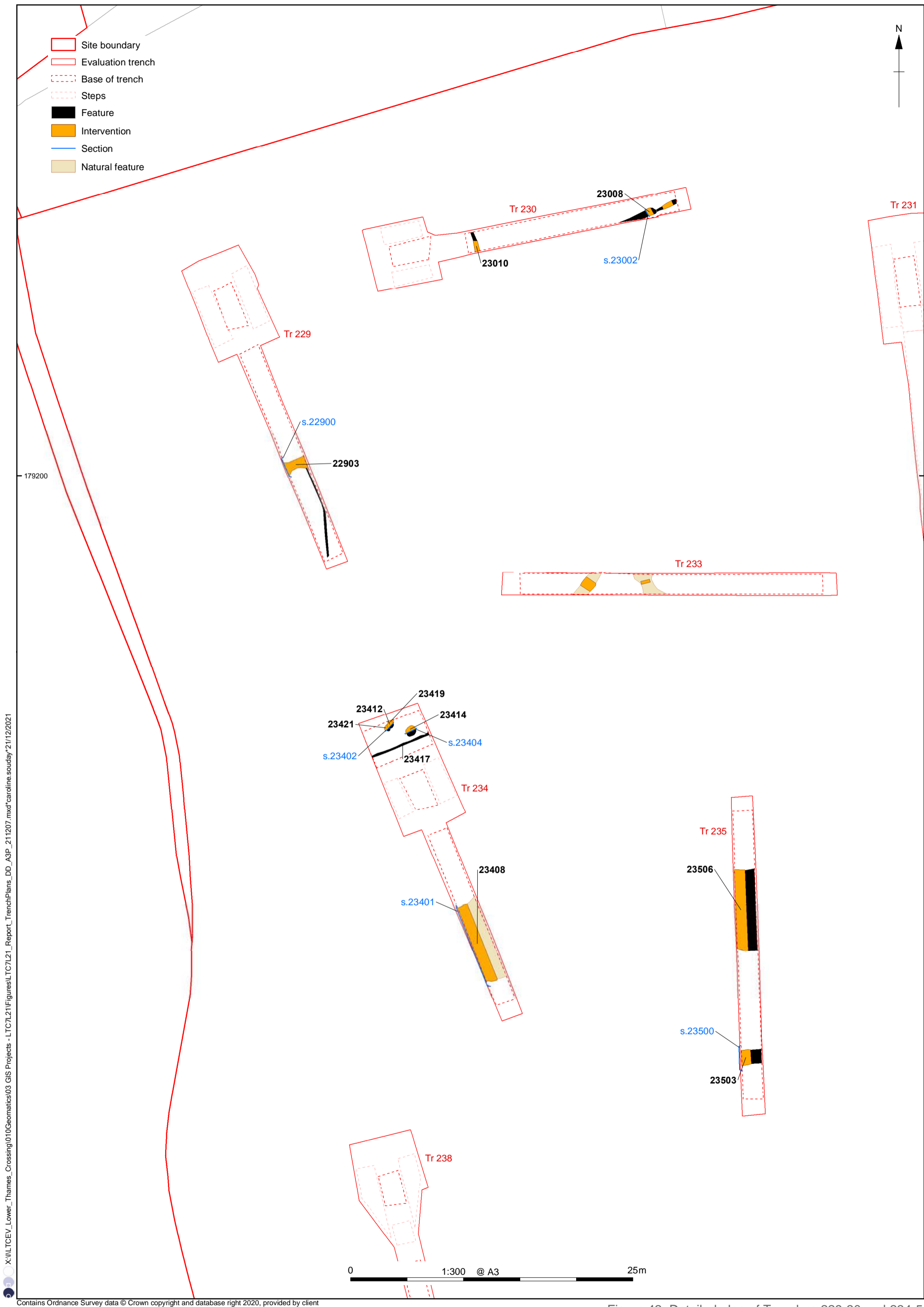

Figure 41: Sections 16100, 19700, 19801, 20701, 21300, 21600, 22300



Contains Ordnance Survey data © Crown copyright and database right 2020, provided by client

Figure 42: Detailed plan of Trenches 229-30 and 234-5



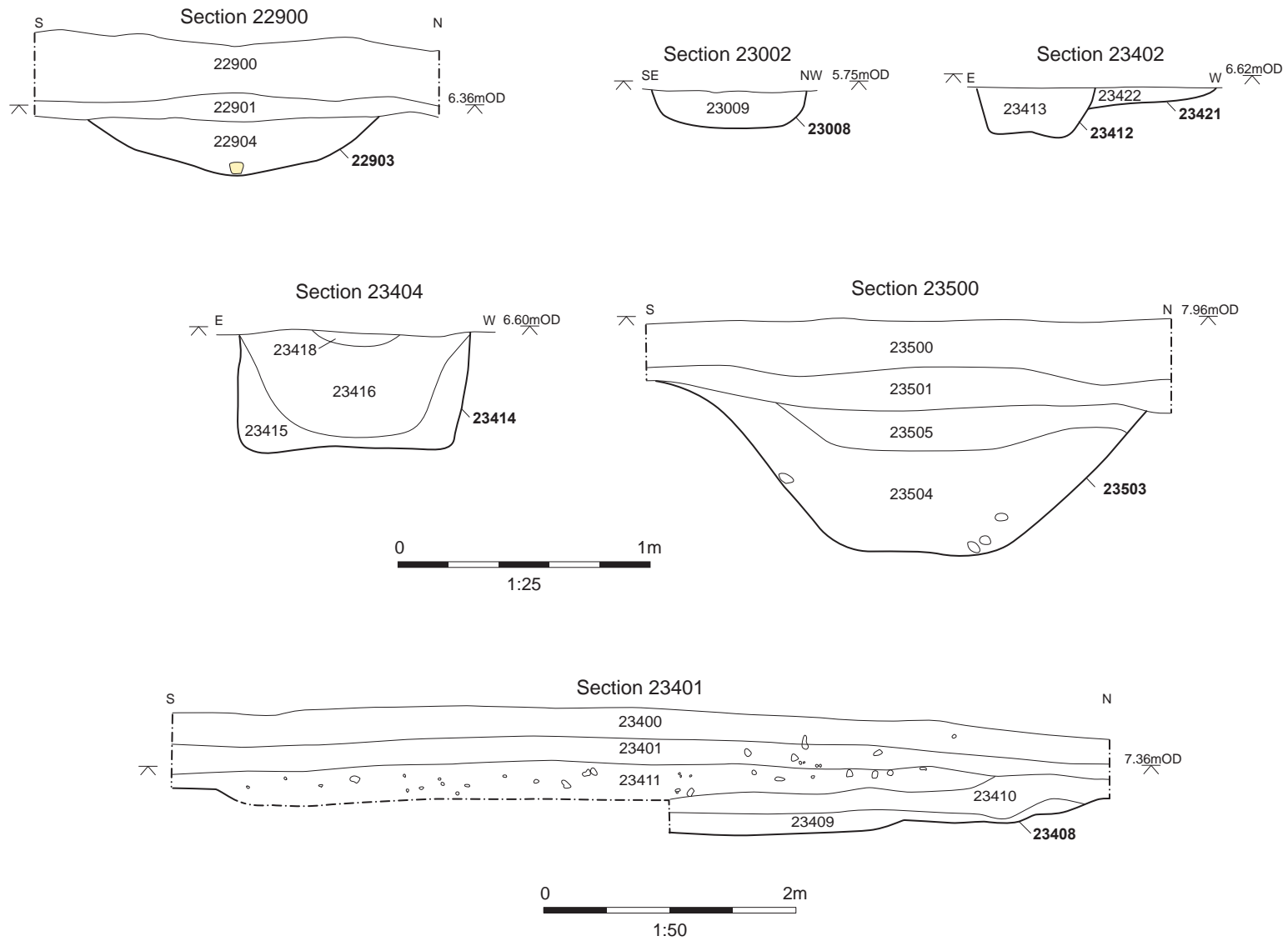
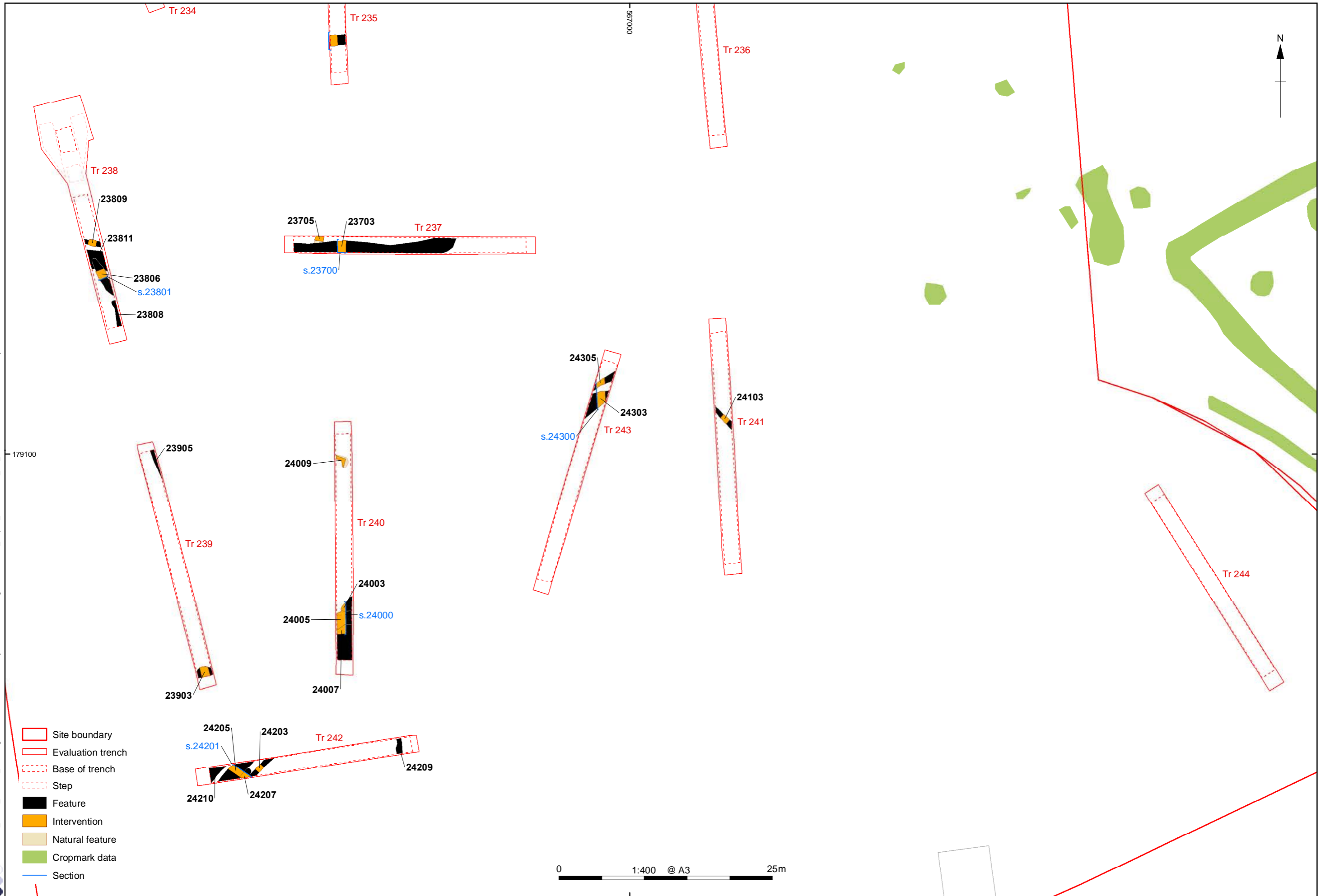

Figure 43: Sections 22900, 23002, 23402, 23404, 23401, 23500

X:\ILTCEV\_Lower\_Thames\_Crossing\010Geomatics\03 GIS Projects - LT\7L21\Figures\LT7L21\_Report\_TrenchPlans\_DD\_A3L211207.mxd\*caroline.souday\*21/12/2021



- Site boundary
- Evaluation trench
- Base of trench
- Step
- Feature
- Intervention
- Natural feature
- Cropmark data
- Section

Contains Ordnance Survey data © Crown copyright and database right 2020, provided by client

Figure 44: Detailed plan of Trenches 237-43

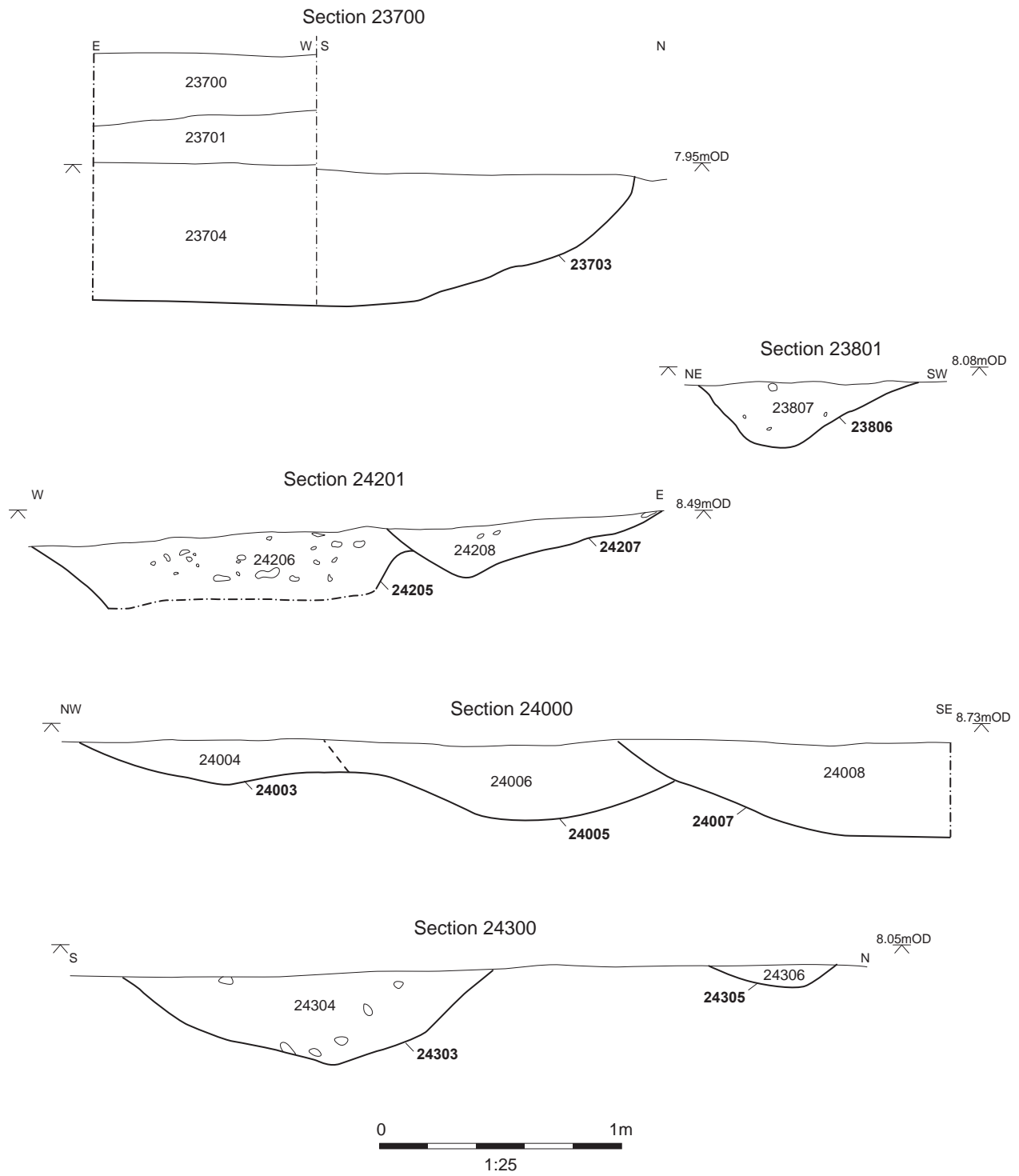

Figure 45: Sections 23700, 23801, 24000, 24201, 24300

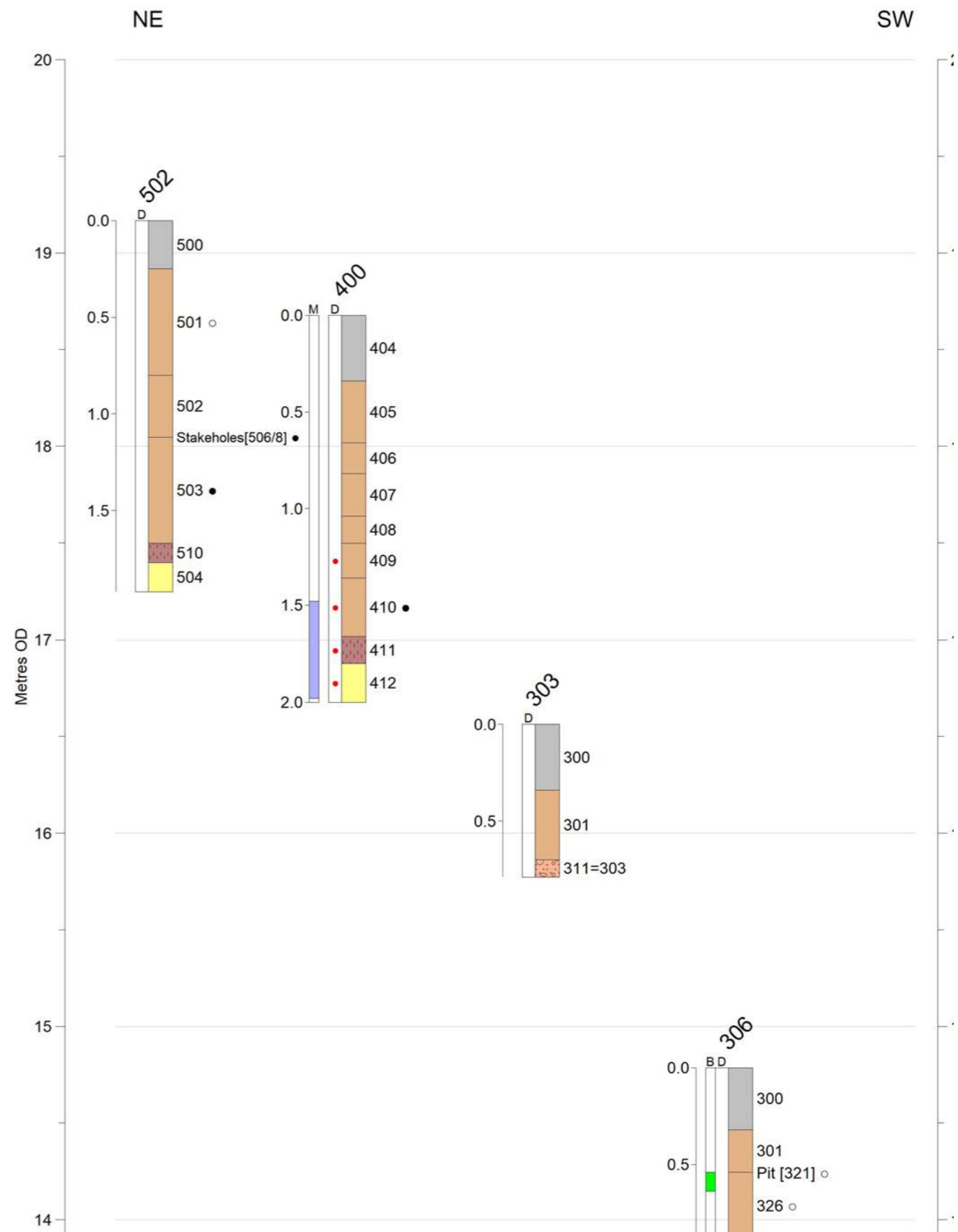
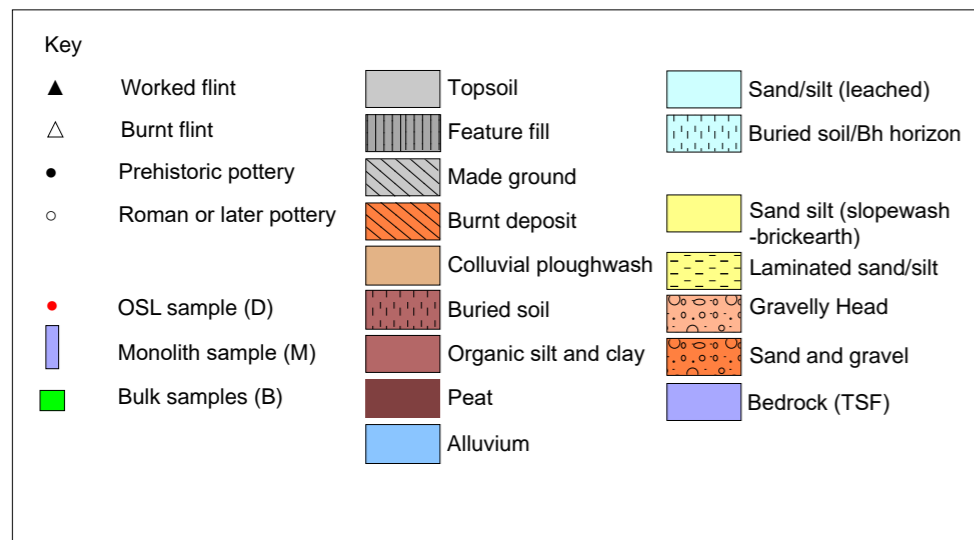

Figure 46: Geomorphological Transect 1: Trenches 5, 4 and 3

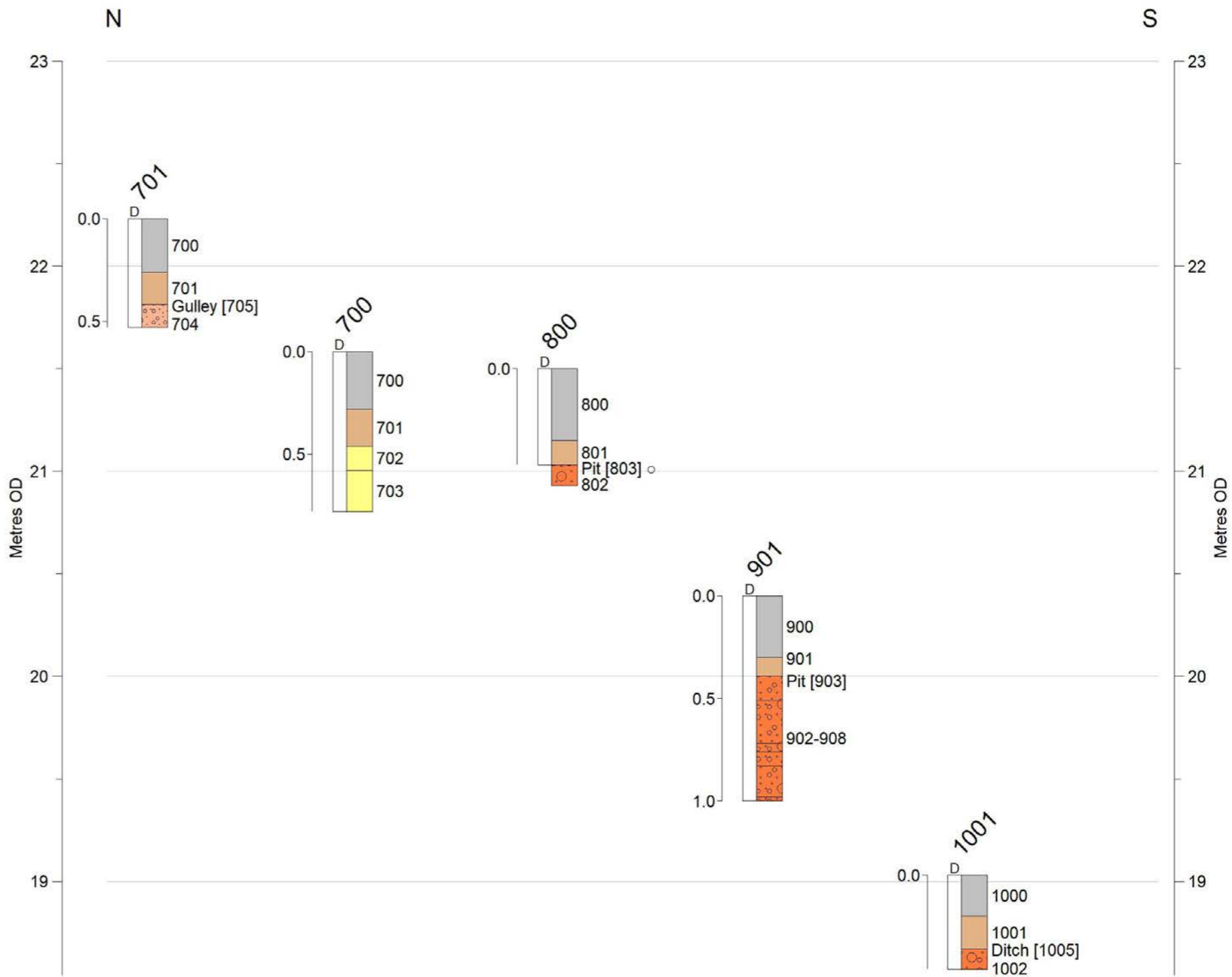
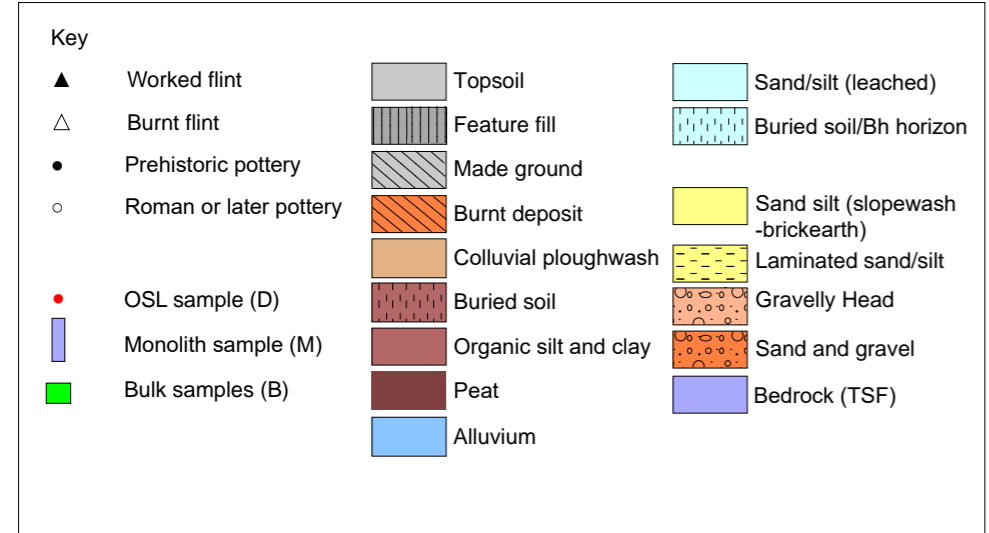

Figure 47: Geoarchaeological Transect 2: Trenches 7, 8, 9 and 10



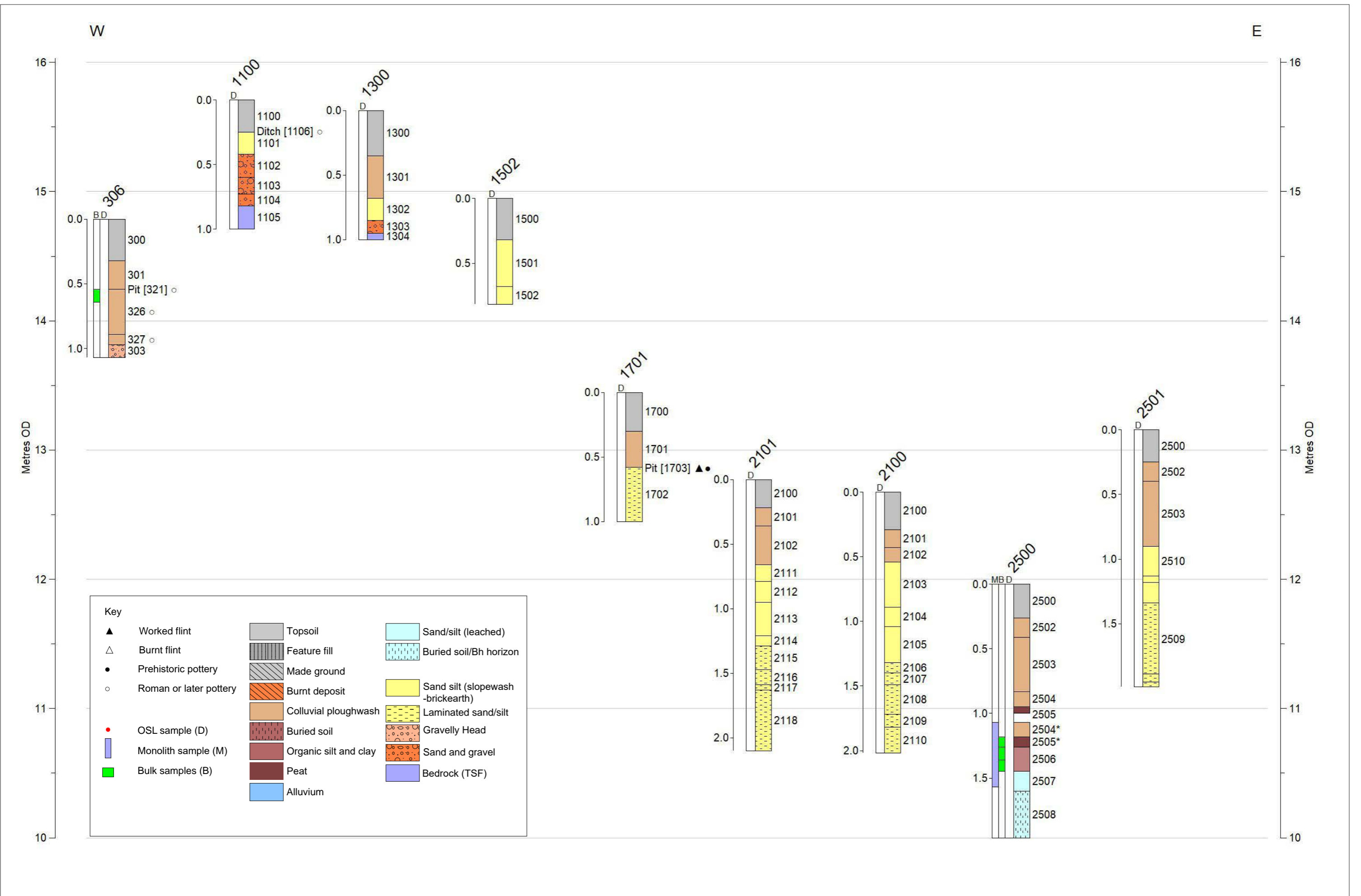

Figure 48: Geoarchaeological Transect 3: Trenches 3, 11, 13, 15, 17, 21, and 25

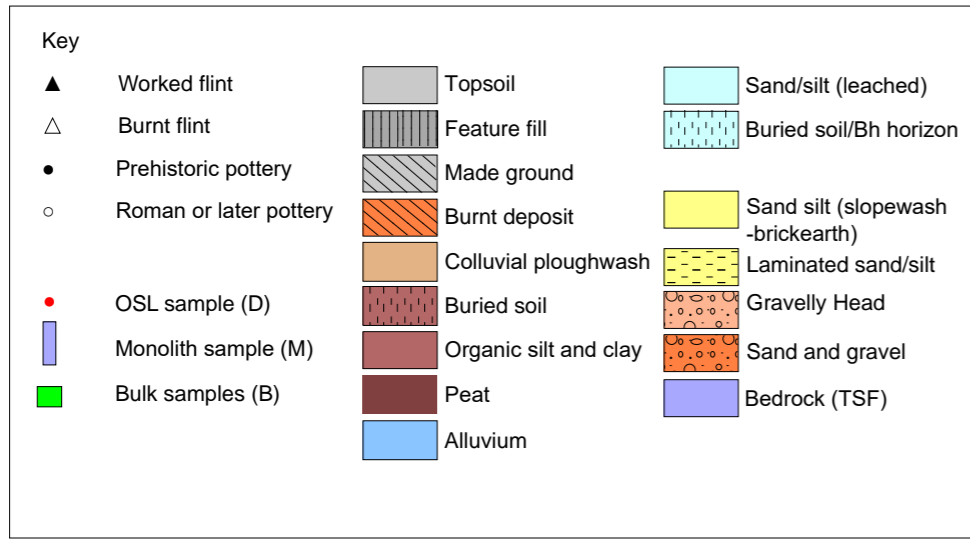
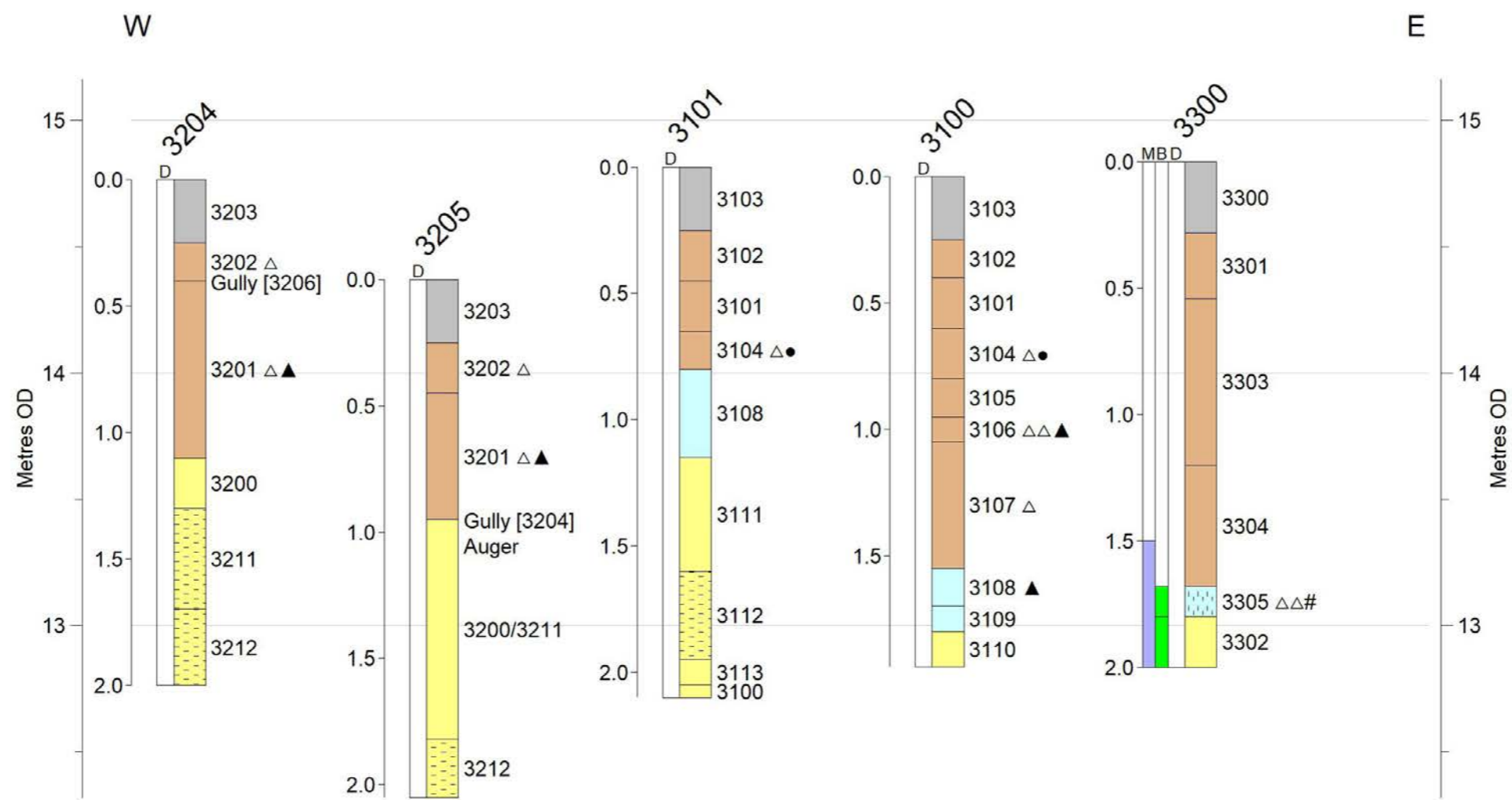
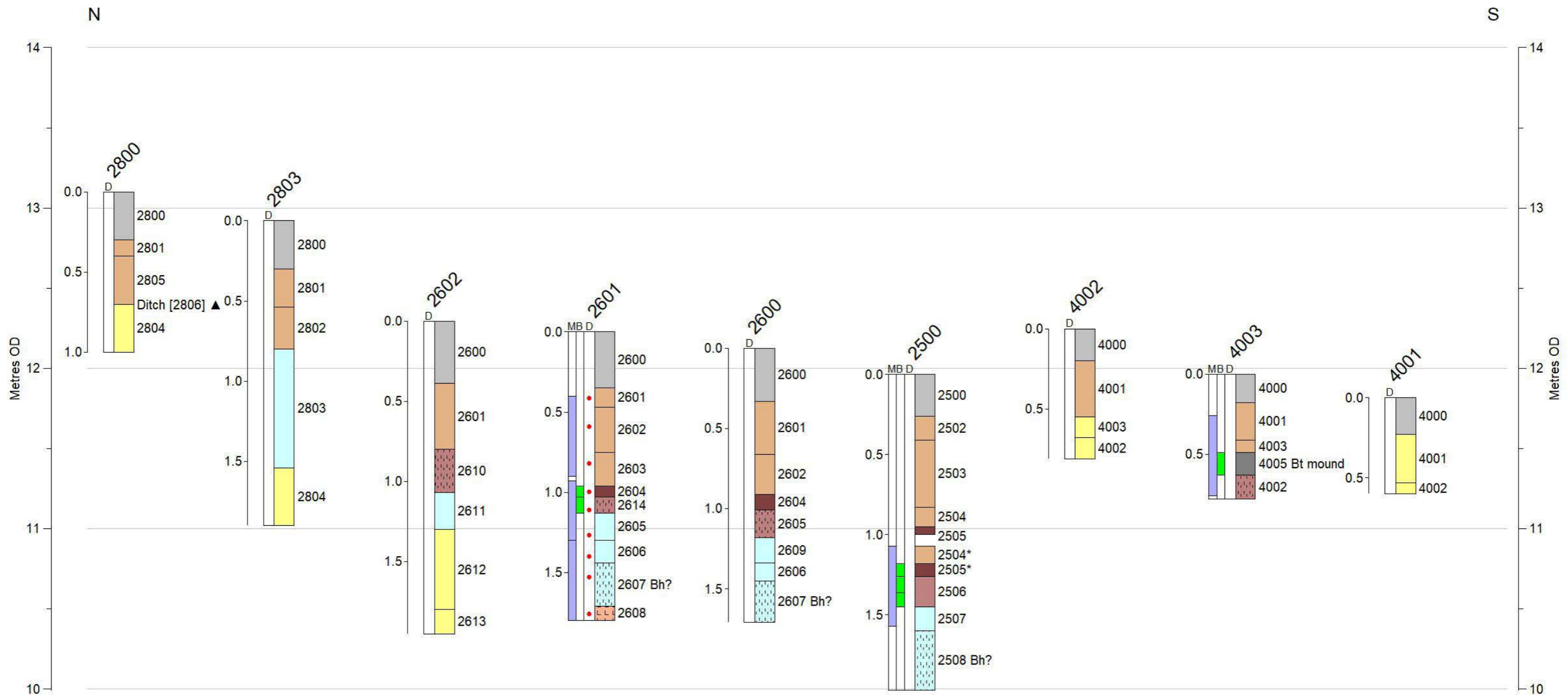

Figure 49: Geoarchaeological Transect 4: Trenches 32, 31 and 33



Key		
▲	Worked flint	Topsoil
△	Burnt flint	Feature fill
●	Prehistoric pottery	Made ground
○	Roman or later pottery	Burnt deposit
•	OSL sample (D)	Colluvial ploughwash
■	Monolith sample (M)	Buried soil
■	Bulk samples (B)	Organic silt and clay
		Peat
		Alluvium
		Sand/silt (leached)
		Buried soil/Bh horizon
		Sand silt (slopewash-brickearth)
		Laminated sand/silt
		Gravelly Head
		Sand and gravel
		Bedrock (TSF)

Figure 50: Geoarchaeological Transect 5: Trenches 28, 26, 25 and 40



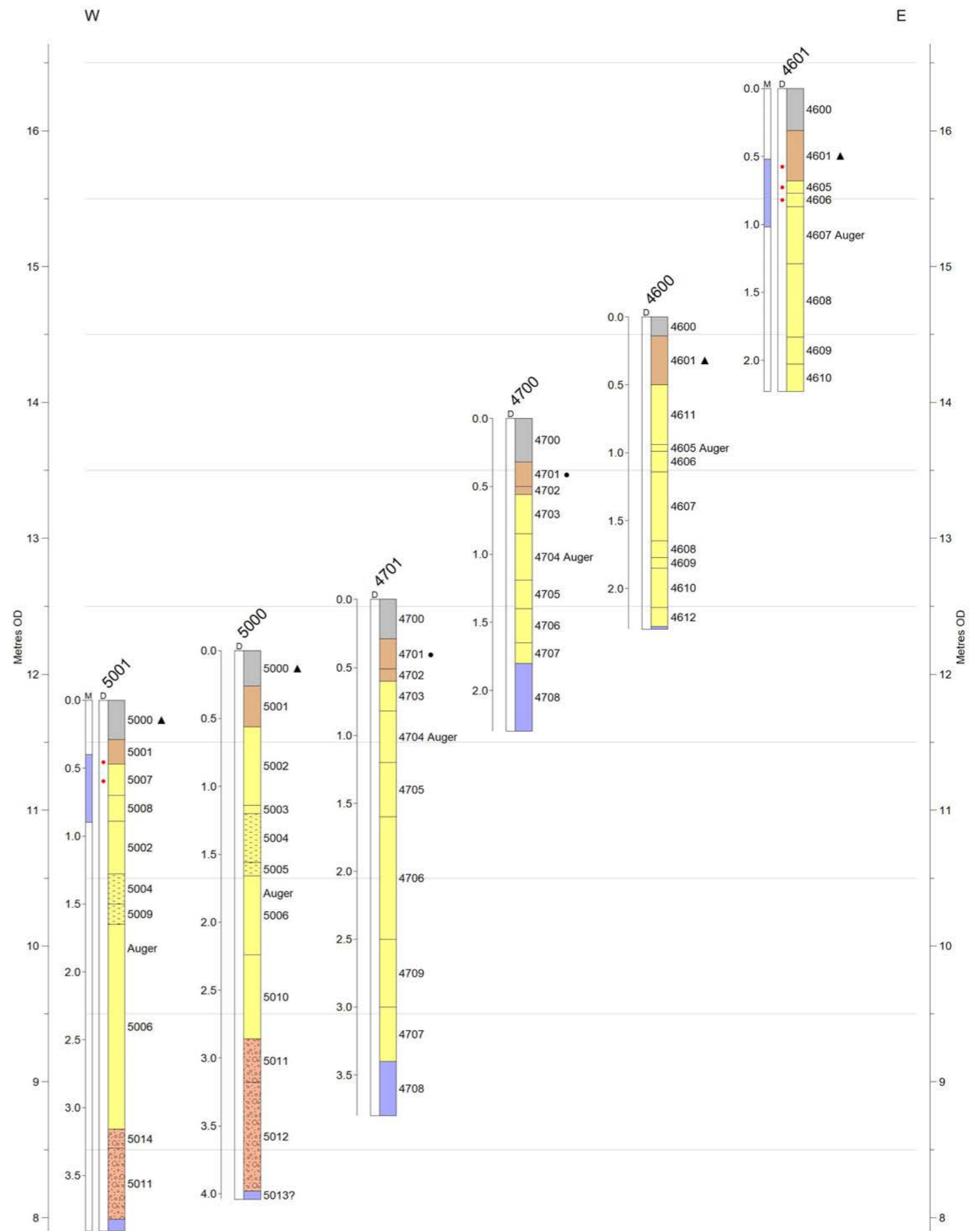
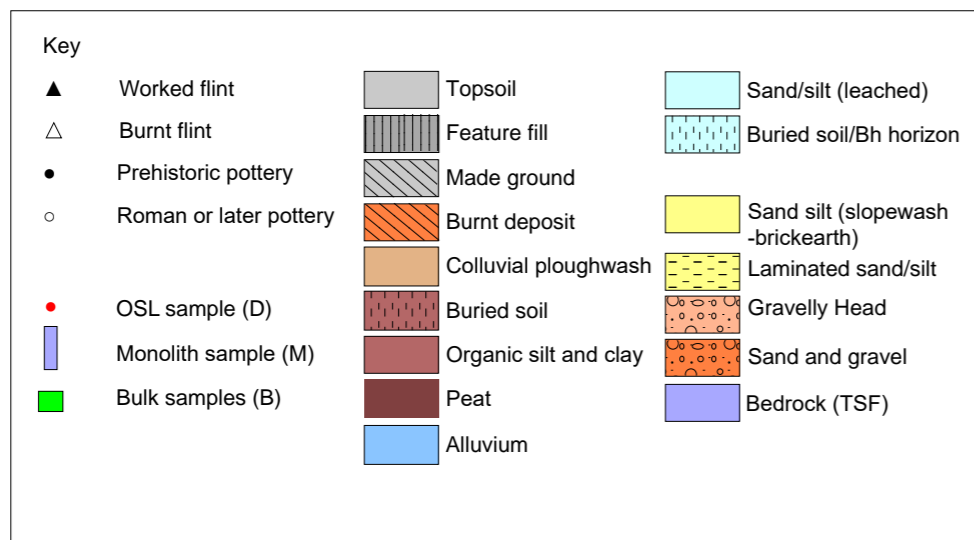
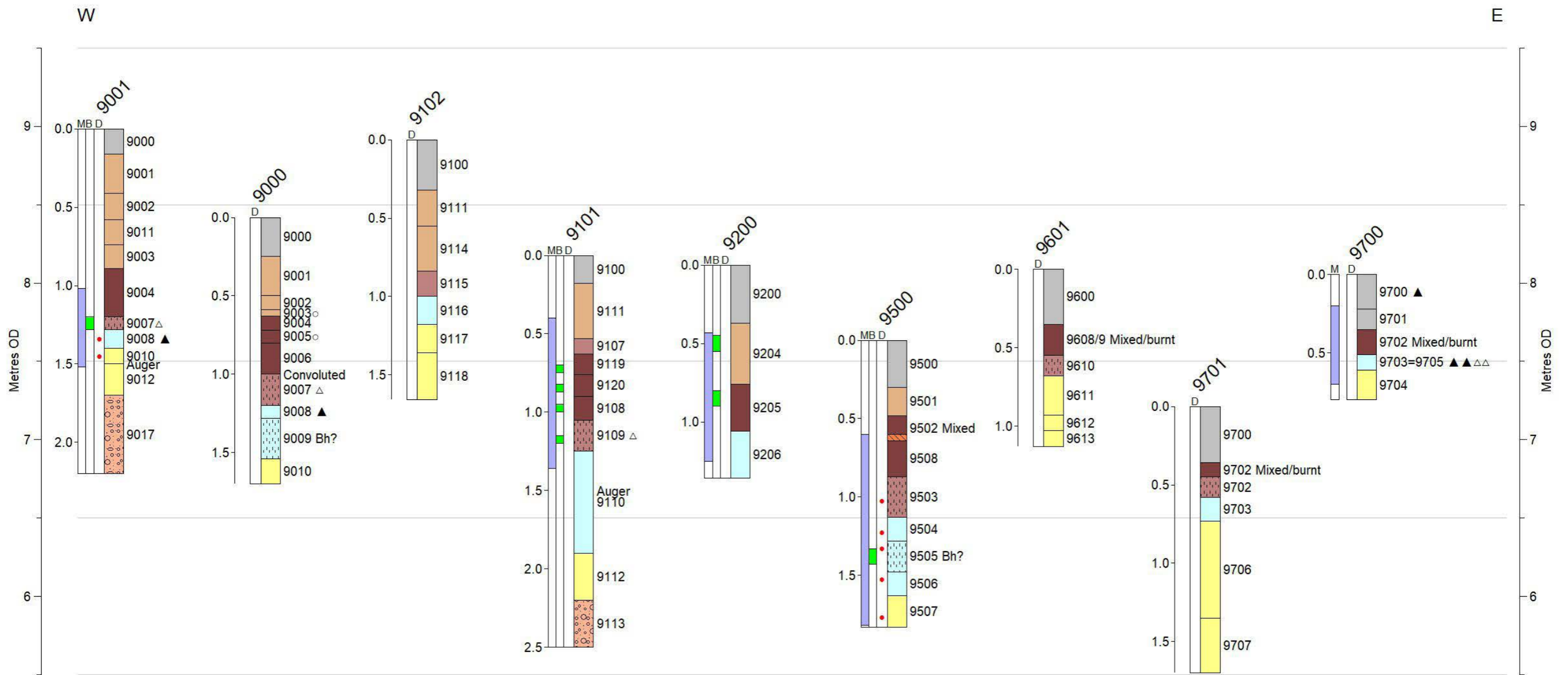

Figure 51: Geoarchaeological Transect 6: Trenches 50, 47 and 46



Key		
▲	Worked flint	Topsoil
△	Burnt flint	Feature fill
●	Prehistoric pottery	Made ground
○	Roman or later pottery	Burnt deposit
•	OSL sample (D)	Colluvial ploughwash
■	Monolith sample (M)	Buried soil
■	Bulk samples (B)	Organic silt and clay
		Peat
		Alluvium
		Sand/silt (leached)
		Buried soil/Bh horizon
		Sand silt (slopewash -brickearth)
		Laminated sand/silt
		Gravelly Head
		Sand and gravel
		Bedrock (TSF)

Figure 52: Geotranssect 7: Trenches 90, 91, 92, 95, 96 and 97

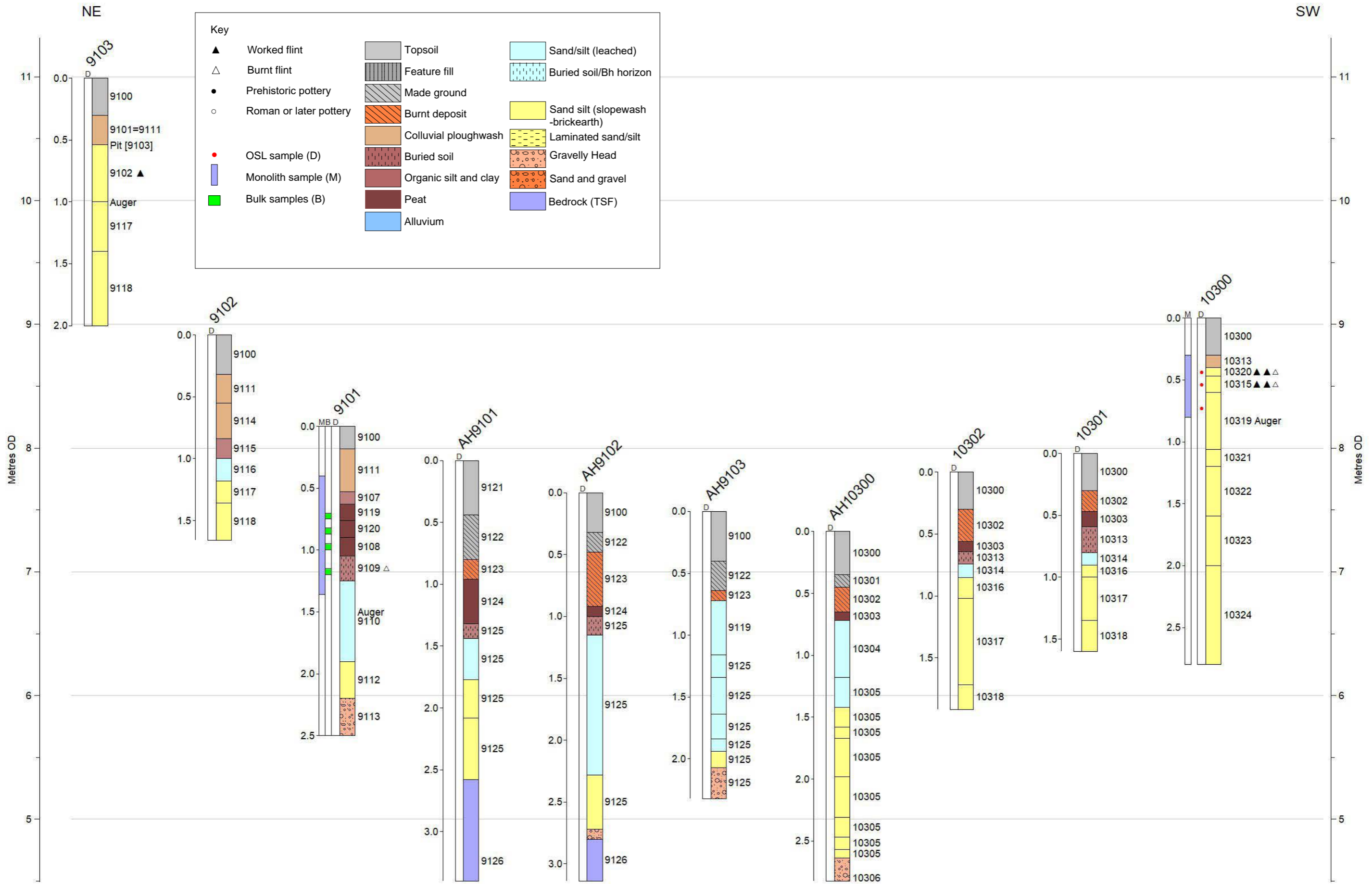

Figure 53: Geoaarchaeological Transect 8: Trenches 91, and 103 (AH denotes auger holes between trenches)

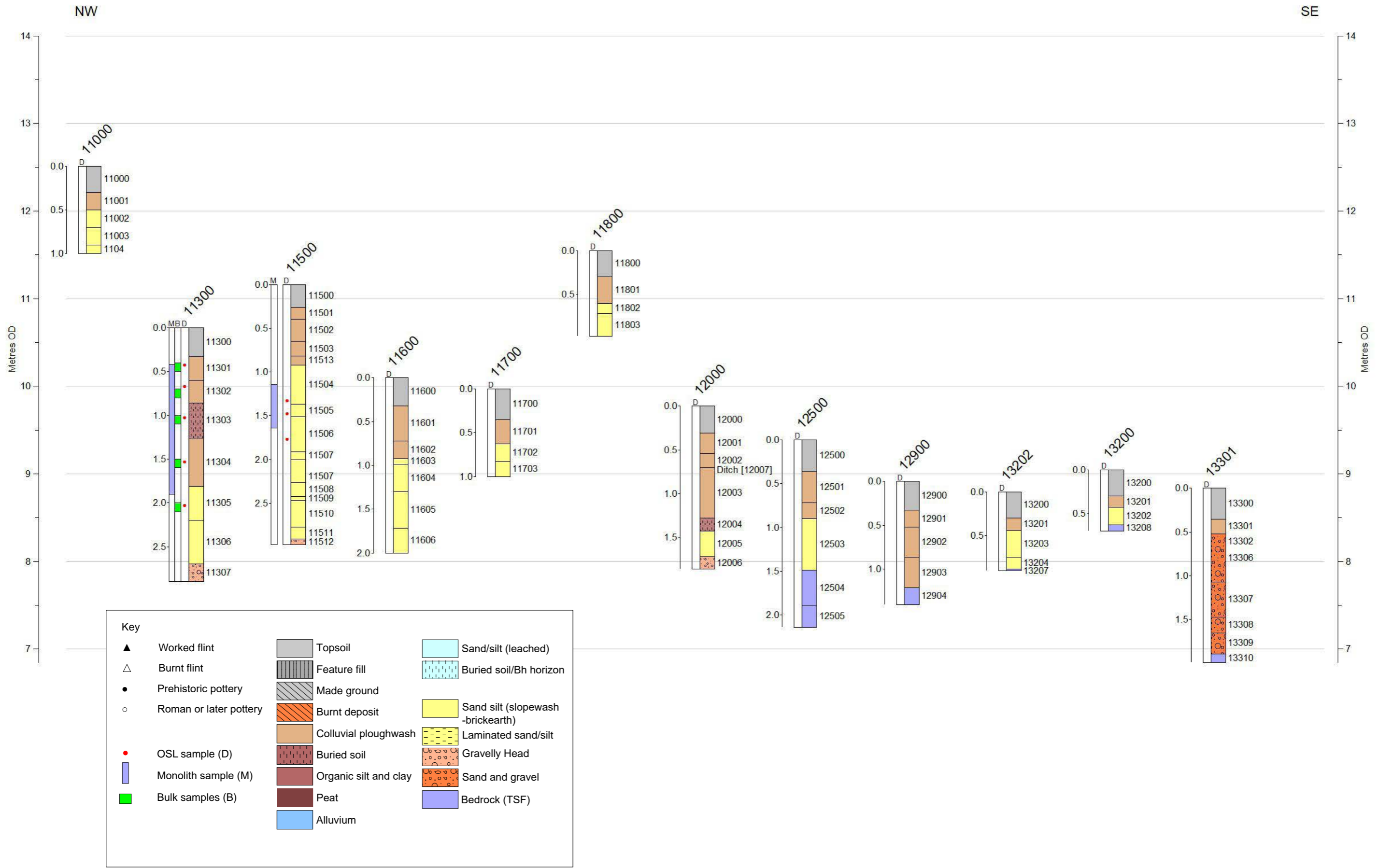

Figure 54: Geoarchaeological Transect 9: Trenches 110, 113, 115, 116, 117, 118, 120, 125, 129, 132 and 133

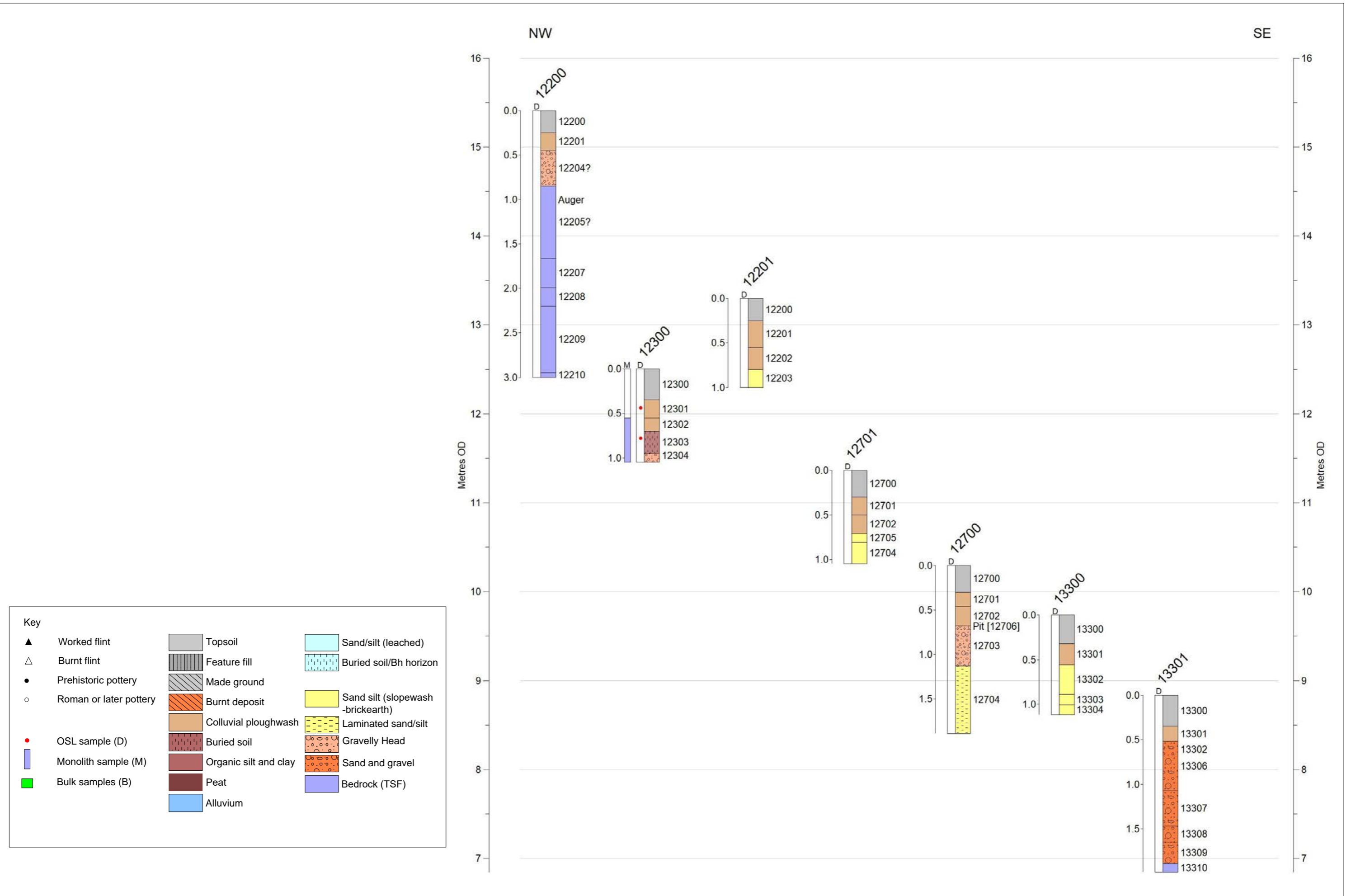

Figure 55: Geomorphological Transect 10: Trenches 122, 123, 127 and 133

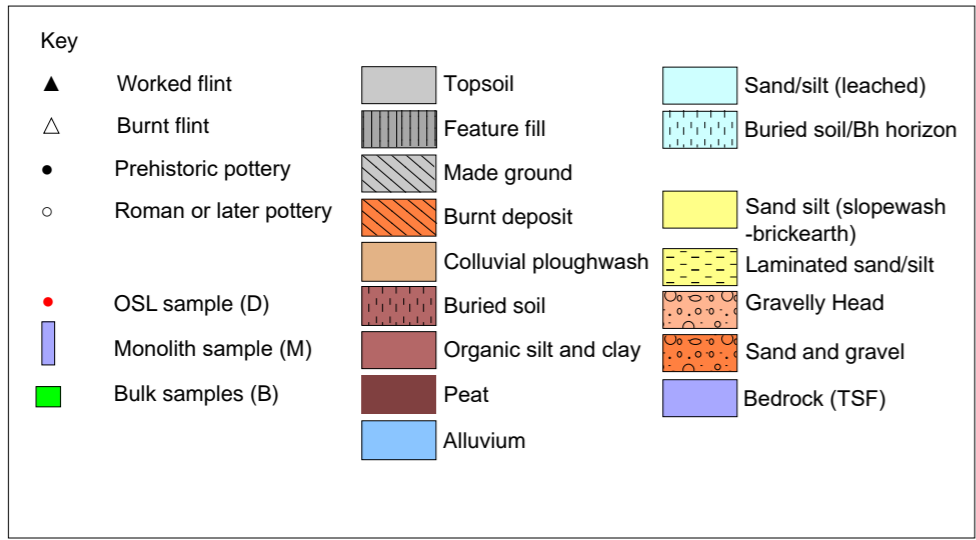
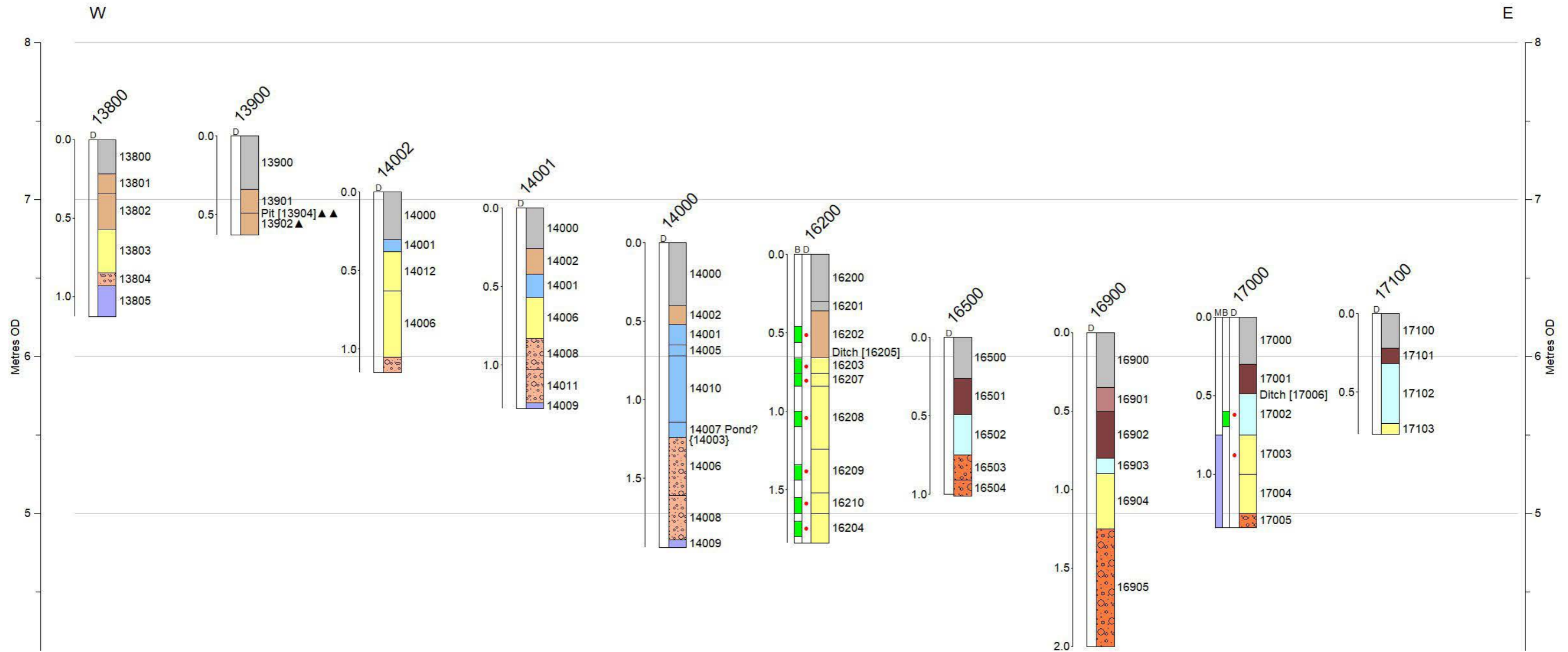

Figure 56: Geomorphological Transect 11: Trenches 138, 139, 140, 162, 165, 169, 170 and 171

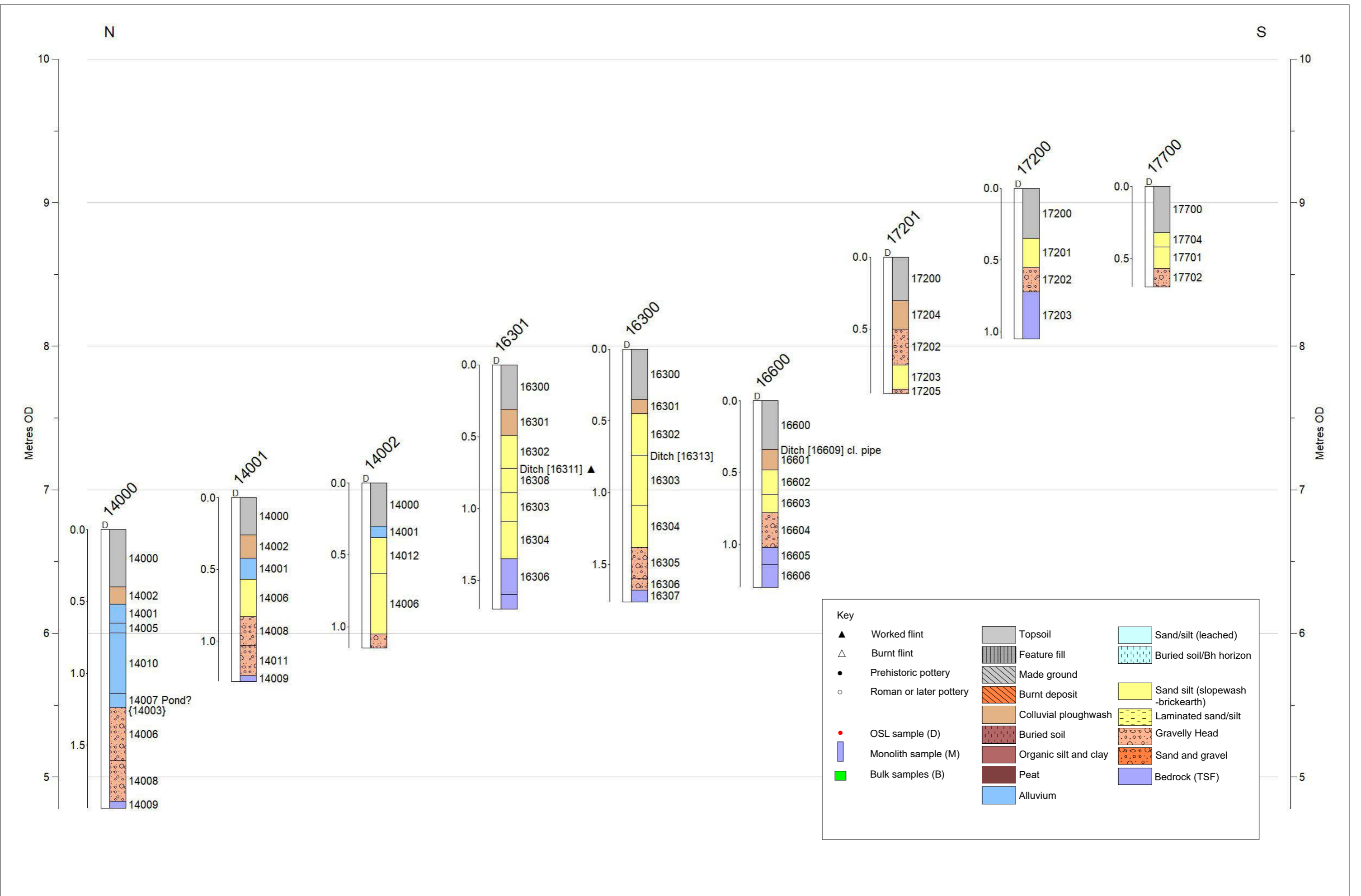

Figure 57: Geoaerchaeological Transect 12: Trenches 140, 163, 166, 172 and 177

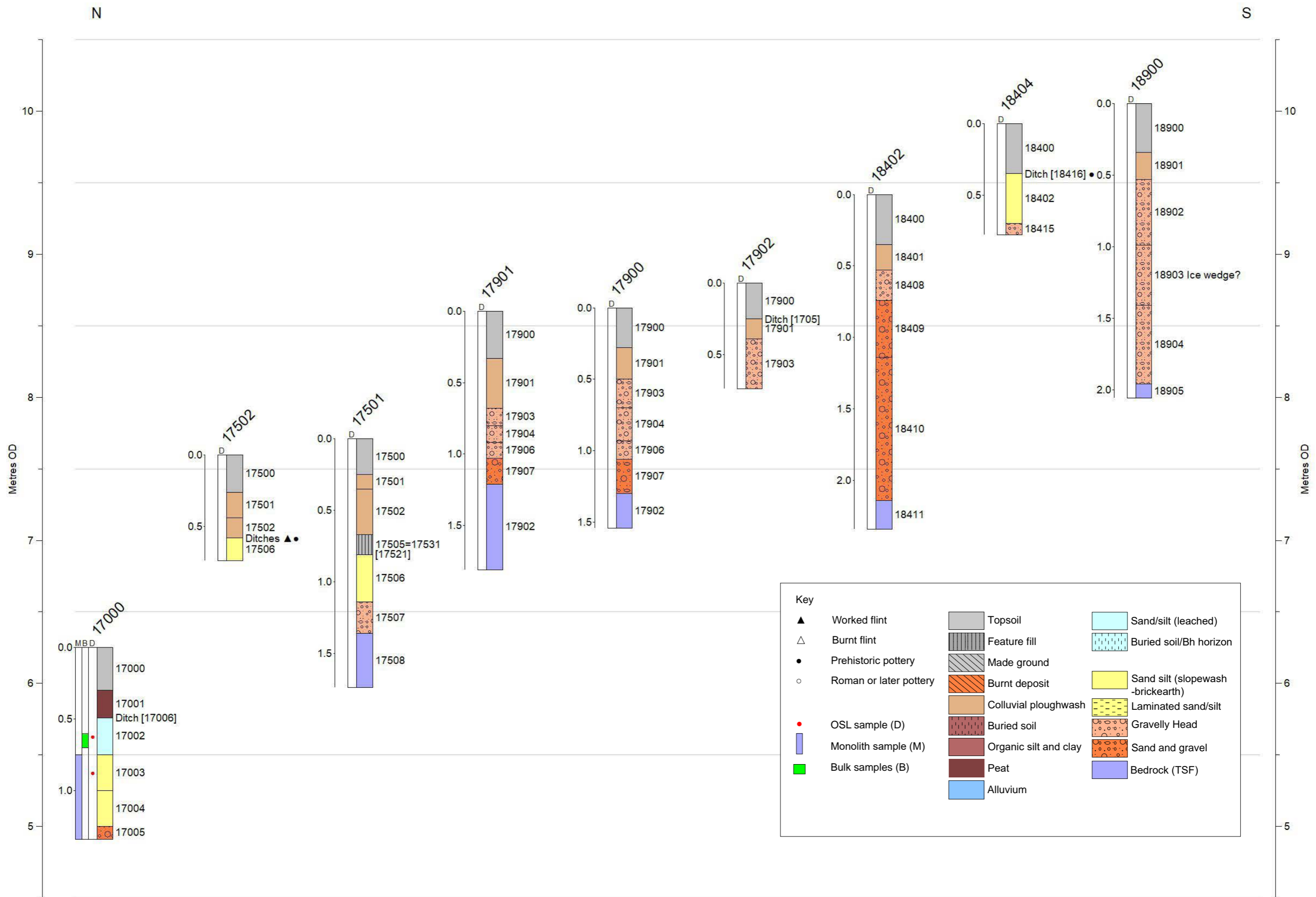
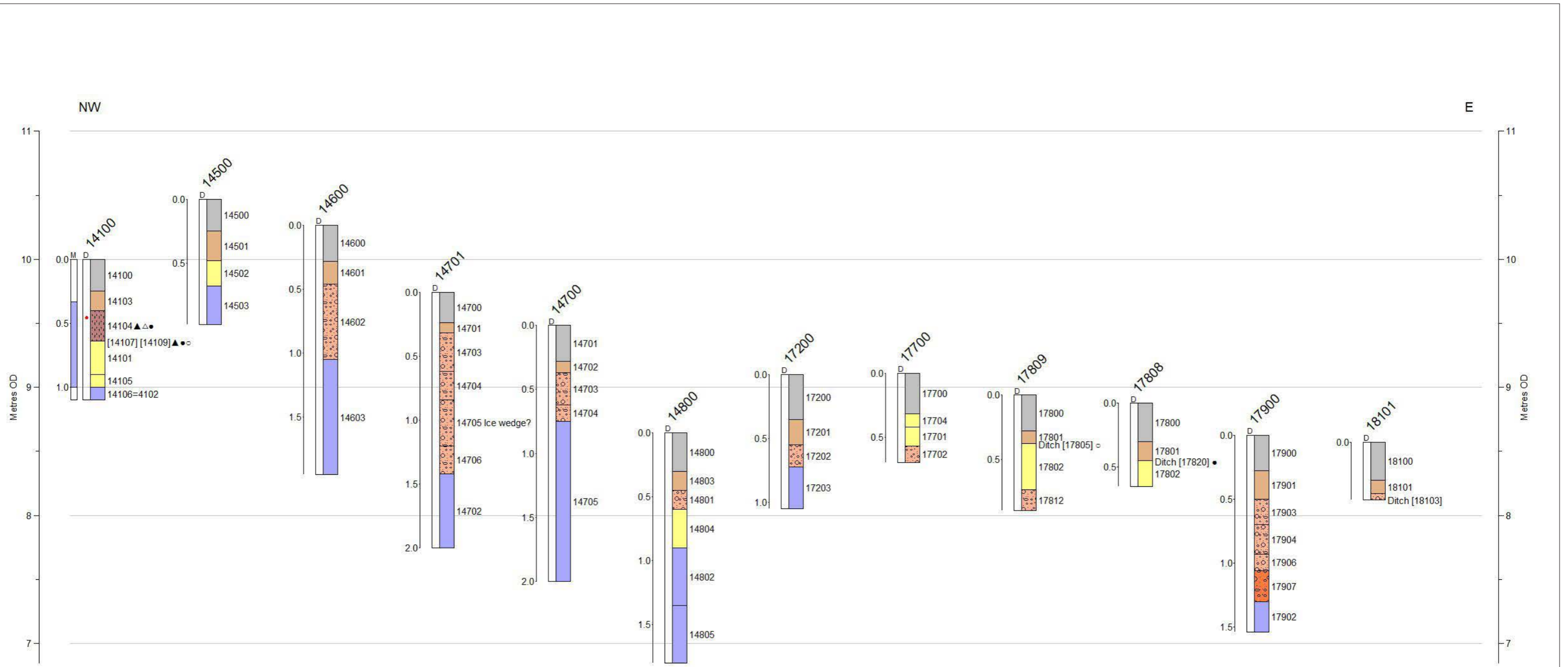

Figure 58: Geoarchaeological Transect 13: Trenches 170, 175, 179, 184 and 189





Key		
▲	Worked flint	Topsoil
△	Burnt flint	Feature fill
●	Prehistoric pottery	Made ground
○	Roman or later pottery	Burnt deposit
●	OSL sample (D)	Colluvial ploughwash
■	Monolith sample (M)	Buried soil
■	Bulk samples (B)	Organic silt and clay
		Peat
		Alluvium
		Sand/silt (leached)
		Buried soil/Bh horizon
		Sand silt (slopewash -brickearth)
		Laminated sand/silt
		Gravelly Head
		Sand and gravel
		Bedrock (TSF)

Figure 59: Geoarchaeological Transect 14: Trenches 141, 145, 146, 147, 148, 172, 177, 178, 179 and 181



Plate 1: Charcoal rich deposit 4005, looking west



Plate 2: Pit 4205, looking north



Plate 3: Pit 4903, looking north



Plate 4: Ditch 6805, looking north-west



Plate 5: Section 10100 showing intercutting features in Trench 101, looking south-east



Plate 6: Possible ditch and pit at the base of Trench 82, looking north-east



Plate 7: View across Trench 91 showing topography, colluvium and conditions, looking east



Plate 8: Pit 9415, looking south



Plate 9: Pit 9404 with tufa block in-situ, looking east



Plate 10: North-west facing section of Trench 103, showing deposits 10320, 10303 and 10302



Plate 11: Trench 104 with the locations of surface flints flagged



Plate 12: North-east facing section of Grid Square ACB, Trench 104



Plate 13: East facing section of Grid Square EAA, Trench 97



Plate 14: Pit 12706, looking south-west





Plate 15: Pit 13813, looking north-west



Plate 16: Possible pond in Trench 140, looking north-west



Plate 17: Ditch 17516, looking south-east



Plate 18: Sections 17504 and 17505, looking south



Plate 19: Pit 17604, looking north



Plate 20: Crouched inhumation 17615, looking south



Plate 21: Pit 17807, looking east



Plate 22: Ditch 19111, looking south-west



Plate 23: Pit 15106, looking south



Plate 24: Ditch 22903 with animal bones, looking south-west



Plate 25: Pit 23414, looking south



Plate 26: Ditch 23806, looking south-east



Plate 27: Pleistocene sand and gravel deposits exposed in Trench 9



Plate 28: Colluvial sequence in Trench 4 (Valley C) with the remnant of a buried soil preserved at the base



Plate 29: Colluvial sequence in Trench 33 (Valley B) with the remnant of a buried soil preserved at the base



Plate 30: Colluvial sequence and peat deposits preserved in the base of Valley B in Trench 25



Plate 31: Radiocarbon dated Late Glacial sequence and overlying prehistoric peat in Trench 95 (note the disturbance and burnt layer in the upper levels of the peat)

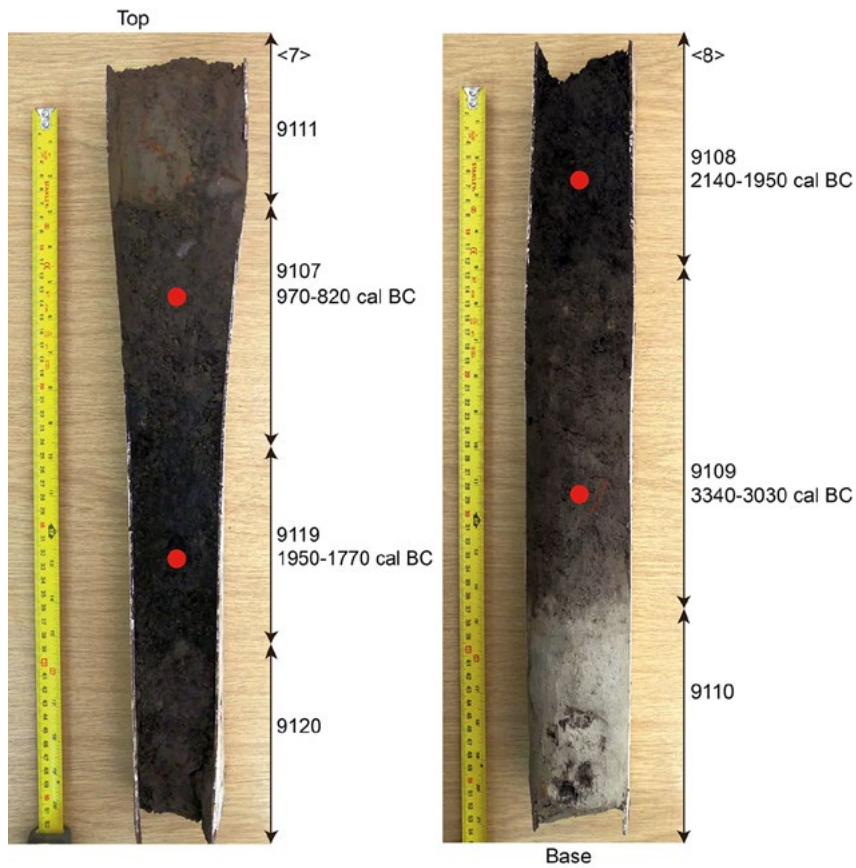

Plate 32: Monoliths from the prehistoric peat sampled for radiocarbon dating in Trench 91





Plate 33: Pleistocene sand and gravel exposed in Trench 133



Plate 34: Pleistocene sand and gravel exposed in Trench 184

## COVER SHEET

<b>Title:</b>	Archaeological Evaluation Report for Trial Trenching of Land Parcel 12, Land South of Low Street, Tilbury Marshes, Essex
<b>Project Name:</b>	Lower Thames Crossing Enabling Works
<b>Ref No:</b>	HE540039-BAL-GEN-GEN-REP-HER-00043
<b>Revision No:</b>	P01
<b>Review Date:</b>	12/02/2022
<b>Status:</b>	S2 – For Information
<b>No. of Pages</b>	148

Rev	Date of Issue	Revision Status	Originator	Checker	Approver
P01	12/02/2022	S2	Conal Mundy	Jack Fletcher	Emily Erswell



# Lower Thames Crossing

Archaeological Evaluation Report for Trial Trenching of  
Land Parcel 12, Land South of Low Street, Tilbury Marshes,  
Essex

Document Number: HE540039-BAL-GEN-GEN-REP-HER-00043

**February 2022**



Revision	Production Date	Prepared by	Checked by	Approved for release by	Sections revised
1.1	11th February 2022	Mark Dodd Project Officer Tim Allen Senior Project Manager Oxford Archaeology	Steve Lawrence Senior Project Manager Oxford Archaeology		

This Evaluation Report has been prepared for Highways England in accordance with the terms and conditions of appointment stated in the Lower Thames Crossing (LTC) Technical Partner Contract. LTC cannot accept any responsibility for any use of or reliance on the contents of this document by any third party.

# Contents

---

Section	Page
<b>Summary</b> .....	<b>6</b>
<b>Acknowledgements</b> .....	<b>7</b>
<b>1 Introduction</b> .....	<b>8</b>
1.1 Project details and scope of work .....	8
1.2 Location, topography and geology .....	8
1.3 Previous investigations .....	9
1.4 Archaeological and historical background.....	10
<b>2 Project Aims</b> .....	<b>22</b>
2.1 General aims .....	22
2.2 Specific objectives .....	23
<b>3 Methodology</b> .....	<b>25</b>
3.1 Constraints.....	25
3.2 Methodology for the evaluation.....	25
<b>4 Results</b> .....	<b>27</b>
4.1 Introduction and presentation of results .....	27
4.2 General soils and ground conditions.....	27
4.3 General distribution of archaeological deposits .....	27
4.4 Trenches 35 and 37 (Figs 3 and 7) .....	27
4.5 Trenches 57, 62 and 66-70 (Figs 4 and 7).....	28
4.6 Trenches 45 and 101 (Figs 5 and 7) .....	29
4.7 Trenches 3 and 7 (Figs 6 and 8).....	29
4.8 Trenches 6, 7, 10, 14 and 18 (Fig 2).....	30
4.9 Trench 67 (Figs 2 and 8).....	31
4.10 Finds summary .....	31
4.11 Environmental summary .....	31
<b>5 Discussion</b> .....	<b>33</b>
5.1 Reliability of field investigation .....	33
5.2 Interpretation.....	33
5.3 Evaluation objectives and results.....	35
<b>Appendix A Trench Tables</b> .....	<b>37</b>
<b>Appendix B Finds Reports</b> .....	<b>91</b>
<b>Appendix C Environmental Reports</b> .....	<b>94</b>
<b>Appendix D References</b> .....	<b>120</b>
<b>Appendix E Abbreviations and Glossary</b> .....	<b>125</b>
<b>Appendix F Site Summary</b> .....	<b>126</b>

## Figures

Figure 1: Site location

Figure 2: Trench layout and cropmark features

Figure 3: Detailed plan of Trenches 35 and 37

Figure 4: Detailed plan of Trenches 57, 62, 66, 68 and 69

Figure 5: Detailed plan of Trenches 45 and 101

Figure 6: Detailed plan of Trenches 3 and 7

Figure 7: Sections 3700, 4500, 5700, 6201, 6600, 6801 and 6900

Figure 8: Sections 300, 301, 702 and 6700

Figure 9: Geoarchaeological transect locations

Figure 10: Geoarchaeological Transect 1: Trenches 27, 23, 21, 18, 15, 14, 9, 3, 7 and 5

Figure 11: Geoarchaeological Transect 2: Trenches 9, 6, 10 and 12

Figure 12: Geoarchaeological Transect 3: Trenches 9 and 13

Figure 13: Geoarchaeological Transect 4: Trenches 9, 14 and 16

Figure 14: Geoarchaeological Transect 5: Trenches 14, 16, 19, 50, 54, 58, 63, 67, 68, 71 and 72

Figure 15: Geoarchaeological Transect 6: Trenches 5, 97, 98, 99, 101, 100, 102, 104, 85 and 92

## Plates

Plate 1: Ditch 4501, looking east

Plate 2: Flint spread 10106, looking east

Plate 3: General view of Trench 3, looking north-east

Plate 4: Detail of waterlogged wood 308, looking south

Plate 5: Weathered surface of waterlogged wood 308, looking south

Plate 6: Extent of the peat in Trench 14

Plate 7: Trench 9, Section 901, Pleistocene terrace gravel deposits overlain by Holocene alluvium

Plate 8: Trench 3, Section 300, peat deposits overlain by gleyed and oxidised Holocene alluvium, with monoliths samples

Plate 9: Trench 3, Section 300/301, monoliths <10> and <29> through the peat showing the location of the radiocarbon samples

Plate 10: Trench 10, Section 1000, peat deposits overlain by gleyed and oxidised Holocene alluvium

Plate 11: Trench 50, Section 5000, Holocene alluvial sequence (laminated towards base) with intercalated stabilization/buried soil horizon in the upper sequence

Plate 12: Trench 67, Section 6700, Holocene alluvium sequence with intercalated stabilization/buried soil horizon with monolith samples

Plate 13: Trench 101, Section 10100, Holocene alluvium sequence with intercalated stabilization/buried soil horizon

## Tables

Table 1: Details of the contexts sampled for charred plant remains

Table 2: Details of the contexts sampled for waterlogged remains

Table 3: Assessment of charred plant remains

Table 4: Assessed remains within the waterlogged samples

Table 5: Waterlogged wood species identification

Table 6: Radiocarbon sample details and calculated age ranges

Table 7: Results of paired  $\chi^2$  tests on peat samples from monolith 305 at 170-180mm (end points of the combined date are rounded out by 10 years)

Table 8: Results of paired  $\chi^2$  tests on peat samples from monolith 307 at 280-290mm (end points of the combined date are rounded out by 10 years)

Table 9: Summary of geoarchaeological section locations

Table 10: Summary of samples from the sedimentary sequences

## Summary

---

Oxford Cotswold Archaeology was commissioned by Balfour Beatty to undertake a trial trench evaluation of Land Parcel 12 covered by WSI R of the Lower Thames Crossing Pre-Enabling Works. This land parcel is located between West Tilbury and East Tilbury within the county of Essex and Thurrock unitary authority (NGR 567179, 177141). A total of 98 trenches were excavated and recorded between 1st September and 27th October 2021.

As anticipated from existing borehole data, the trenches revealed that most of the site was covered in Holocene alluvium to a depth in excess of 2m. At the north-west edge of the site, however, Pleistocene gravels were exposed at the northern end of Trench 9, and were located by augering in several adjacent trenches, indicating that a gravel shelf existed at relatively shallow depth along this edge of the site. The remainder of the trenches were unable to expose the full sequence of Holocene deposits or establish clearly whether there was archaeological activity upon this shelf.

The earliest artefact from the site was a blade-like flake recovered from an alluvial deposit in Trench 18, not far beyond the edge of the gravel shelf. This piece was probably Mesolithic/early Neolithic in date but was likely to have been redeposited, despite being in good overall condition.

At just below 2m down, Trench 3 revealed a peat deposit with a layer of waterlogged wood remains. The main concentration of wood was close to the surface of the peat, and included substantial lengths of roundwood trunks that had split in half, and had subsequently been heavily eroded, presumably during exposure prior to burial by later alluvial deposits. Several of the surrounding trenches also revealed peat with waterlogged wood preservation, but none of the wood exhibited signs of working.

The wood was mostly aligned from SW to NE parallel to the edge of the gravel terrace, and is believed to have split naturally from a mixed carr-type woodland comprising conifers, ash, alder and oak. A series of samples submitted for radiocarbon dating indicated that this peat accumulated from the late Neolithic to the end of the early Bronze Age. This is consistent with peat formation elsewhere on the Lower Thames floodplain. Two pieces of struck flint and a burnt flint were also found in this layer, a hard-hammer struck flake being consistent with the date of the wood upon which it was found.

A later dark brownish grey clayey silt horizon was evident in a number of trenches across the site, and was interpreted as a buried soil horizon. A fragment of charcoal from this was radiocarbon-dated to 780-510 cal BC, showing that this deposit must have formed in or after the early Iron Age. Animal bone fragments were found on this horizon in a nearby trench. A patch of flint cobbles was associated with what is probably the same buried horizon, and may have been hardstanding or possibly related to a path.

The majority of the trenches revealed sterile alluvial deposits formed from successive phases of inundation. The only other features were several post-medieval ditches from two phases of drainage and land partition, the earlier probably 16th - 18th century, the later matching land boundaries on 19th century historic maps.



## Acknowledgements

---

Oxford Cotswold Archaeology would like to thank the client, Balfour Beatty, for commissioning this project and managing the site safety and attendances. Thanks are also extended to the Historic Environment Consultant, Richard Havis of Place Services at Essex County Council, who advises the Borough of Thurrock, for monitoring and providing advice throughout the project.

The project was managed for Oxford Cotswold Archaeology by Steve Lawrence. The fieldwork was directed by Mark Dodd and the site was supervised by Nat Pacholek and Tom Bruce. They were supported by Agata Kowalska, Anthony Haskins, Ashley Pooley, Benjamin Massey, Benjamin Slader, Benjamin Slader, Chloe Groves, Chris Griffiths, Christopher Smallwood, Ciar Boyle Gifford, Dan Firth, David East, Dominic Allen, Edmund Cole, Graeme Botham, Harlie Mason, Harry Mixer, Holly Wright, Josie Francis, Kamil Prus, Lily Andrews, Marionna Sandin Catacora, Mel Harvell, Richard Spencer, Rose Britton, Sam Oxley, Tanja Peter, Tara Schug, Tim Sperring, Tom Hayes, Tomasso Rossi, Tomasz Neyman and Yeraí Francisco-Benet. Site survey was undertaken by Caroline Souday and Lily Andrews and digitising was carried out by Caroline Souday and Charles Rousseaux. Thanks are also extended to the teams of OA staff that cleaned and packaged the finds under the management of Natasha Dodwell, processed the environmental remains under the management of Rebecca Nicholson, and prepared the archive under the management of Nicola Scott.

# 1 Introduction

---

## 1.1 Project details and scope of work

- 1.1.1 The Lower Thames Crossing Project is located between the A2 in Kent and the M25 in the London Borough of Havering. It will run underneath the River Thames through a tunnel and emerge on the northern side of the river at East Tilbury. From the North Portal the road will run to the M25 at Junction 29 via the A13 and pass between North and South Ockendon. The development of the project is managed by LTC, a partnership between Highways England and a consultancy joint venture set up to oversee the scheme.
- 1.1.2 A programme of archaeological trial trenching commenced in the Essex part of the scheme in November 2019. A scheme-wide specification for trial trenching was written by LTC (Highways England 2018), and in July 2019, LTC commissioned Balfour Beatty to deliver the pre-Enabling Works. Balfour Beatty appointed Oxford Archaeology (OA) to prepare a project-wide written scheme of investigation (WSI) for the scheme, which (at the request of the key archaeological stakeholders) is divided into two parts, one for the Kent section, and another for Essex and Havering (Oxford Archaeology 2020a; 2020b).
- 1.1.3 Following completion of the project-wide WSIs, OA was instructed to prepare a series of site-specific or group-site specific WSIs for approval by the key archaeological stakeholders in advance of trial trenching to inform the Development Consent Order (DCO). A detailed WSI was created for Land Parcels 12, 13, 20, 38, 129, 130, 135 and 136 prior to the trial trenching (WSI R, Oxford Archaeology 2021), which details the archaeological background and potential within the site. It also sets out the archaeological aims and objectives appropriate to the investigation of this land parcel by trenching and describes the methodology to be applied. The WSI was approved by Richard Havis, Principal Historic Environment Consultant for Place Services at Essex County Council, prior to the start of the fieldwork. Oxford Cotswold Archaeology (OCA) was commissioned as Balfour Beatty's archaeological contractor to undertake the evaluation in accordance with the approved WSI and local and national planning policies.
- 1.1.4 Only Land Parcel 12 was accessible for this phase of work and fieldwork was completed here between 1st September and 27th October 2021. All work followed the MoRPHE Project Manager's guide (Historic England 2015a), and the Code of Conduct of the Chartered Institute for Archaeologists (CIfA). The archaeological works adhered to the standards and guidance for archaeological evaluation, excavation and archiving (CIfA 2014a; CIfA 2014b). No fieldwork has been undertaken in Land Parcels 13, 20, 38, 129, 130, 135 and 136.
- 1.1.5 The work was monitored by Richard Havis of Place Services on behalf of the Borough of Thurrock.

## 1.2 Location, topography and geology

- 1.2.1 The following section is taken from the detailed WSI and includes the coverage of all land parcels within that document (OA 2021).

- 1.2.2 Land Parcels 12, 13, 20, 38, 129, 130, 135 and 136 are hereafter referred to as the 'site' within the boundary of the scheme. The site is located in the parishes of East Tilbury and West Tilbury which is now part of the Borough of Thurrock in Essex (Fig. 1) (NGR 567179,177141). The parish boundary between East and West Tilbury cuts through part of the site. Land Parcels 12,13 and 20 are located in the parish of West Tilbury and Land Parcels 38, 129,130, 135 and 136 are located in the parish of East Tilbury. The site is located north and south of Church Road which continues eastward as Station Road. Several farm tracks are also located within the eastern part of the site. The London, Tilbury and Southend Railway is located just north of the site with the exception of Land Parcel 13 which is located just north of this railway line.
- 1.2.3 The bedrock geology is mixed, with the north-eastern part of the site (Land Parcels 135 and 136) underlain by Thanet Sand. The southern part of the site (Land Parcels 12, 13, 20, 38, 129 and 130) is underlain by chalk. The superficial geology of the site is also mixed with the areas of chalk bedrock overlain with alluvium and peat. The higher areas of ground with Thanet Sand are overlain by Taplow Gravels and Head Clay (BGS 2020).
- 1.2.4 Much of the area has been used as a landfill site. Historic landfill covers Land Parcels 38 and 129, as well as the area south-east of Land Parcel 38. The southern part of Land Parcel 12 is a current landfill site. The site is currently used mostly for agricultural purposes. Outside the landfill area, Land Parcel 12 comprises two arable fields and parts of two others which are divided by drainage ditches. One small part of Land Parcel 12 is located just north of Station Road and this is an area of rough pasture. Another small part of Land Parcel 12 and the adjacent Land Parcel 20 are open fields just north of an electrical substation. The northern part of Land Parcel 38 is an open field whereas the southern part is in arable use. Land Parcel 130 is another open field which may be rough pasture. Land Parcel 13 is an arable field just north of the Tilbury railway line. Land Parcel 135 comprises two arable fields which are located either side of a track. Land Parcel 136 is also an arable field.
- 1.2.5 The site is situated within a lowland area with an estuarine character. The lowest areas of the site are Land Parcels 12, 13, 20, 38 and 129 which are located at c 1m aOD. Land Parcels 130, 135 and 38 are slightly higher at 3-5m aOD. The highest land parcel is 136 which is situated on the slopes of a plateau at which extends to the east. This land parcel ranges from c 3m aOD at the north-western edge to c 12m aOD at the south-eastern edge. The nearest watercourse to the site a sinuous feature which divides Land Parcels 12 from Land Parcels 130 and 38. This feature is the boundary line between the parishes of West and East Tilbury and may be the course of a former creek which is now dry. There are also a number of drainage ditches within the southern part of the site which are aligned roughly north-south.

## 1.3 Previous investigations

- 1.3.1 The following sections of known archaeology given below are taken from the detailed WSI for Land Parcel 12 (OA 2021).
- 1.3.2 In 1993 several finds were recorded in north-eastern part of the study area during the construction of the Horndon - Tilbury (Coalhouse Fort) Gas Pipeline. The HER recorded that the only information available from this

watching brief is a catalogue of finds; the report does not appear to be available.

- 1.3.3 An excavation at Gun Hill located 0.8km north-west of the study area recorded features of the following dates: Palaeolithic, Mesolithic, Neolithic to Bronze Age, Roman, Saxon and medieval (Drury and Rodwell 1973).
- 1.3.4 In 2005 and 2014 an evaluation and excavation took place west of the Bata factory and adjacent and north-east of the site. Part of the evaluation took place within Land Parcel 135 of the site. The evaluation and excavation recorded evidence of Neolithic, Bronze Age and Roman activity (Oxford Archaeology 2005; Oxford Archaeology 2016).
- 1.3.5 Wessex Archaeology carried out a geophysical magnetometer survey on behalf of Tilbury Power Station in advance of a proposal to construct a gas main that covered part of the eastern half of Land Parcel 13, a strip 200m wide along the north-west edge of Land Parcel 12, and the south-west corner of Land Parcel 136. The survey identified a possible enclosure against the N-S boundary dividing Land Parcel 13, and another larger possible enclosure with an annex on the west side straddling the boundary between the two westernmost fields within Land Parcel 12, and about 120 m south of the railway line. Around 150m east of the possible enclosure was a line of five large discrete anomalies possibly representing archaeological features. These were from 2.5m to 6m across. No archaeological features were found in the corner of Land Parcel 136, although at least one ditch was found in Land Parcel 37 adjacent that ran up to the south-western boundary of Land Parcel 136, and probably continued into it.
- 1.3.6 In 2020 Oxford Cotswold Archaeology JV carried out trial trenching in Land Parcel 37 for the LTC scheme. Due to the slope and the groundwater flood risk, the south-west edge of the area adjacent to Land Parcel 12 was not evaluated, but the north-east side adjacent to Land Parcel 136 was, and this found ditches and pits of Roman, Saxon and medieval date in trenches close to the southwest edge of Land Parcel 136 (OCA 2021). Late prehistoric pottery was also recovered from pits a little further from the boundary.

## 1.4 Archaeological and historical background

- 1.4.1 **Palaeolithic.** No Palaeolithic finds have been recorded within the site. Several Palaeolithic finds have been recorded within the western and eastern part of the surrounding landscape. A broken hand-axe was recorded 800m east of the site in an area of reclaimed marshland. A Palaeolithic flint scatter was also recorded c 700m west of the site in another area of reclaimed marsh. This included one handaxe, six flakes and 11 retouched flakes.
- 1.4.2 Palaeolithic worked flints including hand axes and flakes have been recorded at Gun Hill on a plateau of higher ground located c 800m north-west of the site.
- 1.4.3 The Palaeolithic potential of the site has been classified as mixed by the LTC geoarchaeological assessment. The southern part of the site (Land Parcel 20,130 and the southern parts of 12 and 38) and the north-eastern parts of the site (Land Parcels 135 and 136) have been classified as having a low-moderate potential. The central part of the site (Land Parcel 13 and the

northern parts 12 and 38) have been classified as having a moderate-high Palaeolithic potential. Late Upper Palaeolithic remains have been found at the base of alluvium in this area and there may be previously unrecorded deposits of this data that are preserved *in situ*.

- 1.4.4 Mesolithic. No Mesolithic finds have been recorded within the site. It is possible there may be Mesolithic finds buried in the deeper alluvial sequences within the site.
- 1.4.5 Mesolithic finds have been recorded at Gun Hill on the plateau of higher ground c 800m north-west of the site.
- 1.4.6 Neolithic. A Neolithic flint arrowhead was possibly found within central part of the site, although the Essex HER only records the location with four figure grid reference. Pastscape also records another Neolithic flint arrowhead in the vicinity of Land Parcel 136 but this is also recorded as a four-figure grid reference.
- 1.4.7 A possible Neolithic burial was found in the eastern part of the study area in 1892. There is little information with this Pastscape entry, and it only has a four figure grid reference, and is likely to be duplicated with an Essex HER entry. Neolithic - Bronze age flints were found nearby and 0.8km east of the site. Neolithic finds have also been recorded in the northern part of the study area near Muckingford Lane and also at Gun Hill and in the marshland to the south-west of the study area.
- 1.4.8 The Hordon to Coalhouse Gas Pipeline also identified a number of worked flints along the route, and some of these were found within the north-eastern part of the site (Land Parcel 136). These flints were not specifically dated in the HER.
- 1.4.9 **Early to middle Bronze Age.** Three ring ditches and a trackway were recorded c 0.6km north-east of the site. The central ring ditch, which was double-ditched and the largest of the three, was excavated in 1959-60 (Bannister 1961), and human cremated bone and a few small pieces of pottery were recorded in the ditches. The ring ditch contained a cairn which contained a cremation burial of an adult and child dating to 1740-1610 cal BC (GrA28939; 3365±40 BP) (Sheridan 2008, 58). This dates the barrow to the end of the early Bronze Age (or just possible the start of the middle Bronze Age). Two smaller ring ditches located adjacent to the larger barrow were identified as cropmarks in 1980, although one of these was incomplete. A curved trackway was also located next to the ring ditches.
- 1.4.10 The Hordon to Coalhouse Gas Pipeline recorded a cremation cemetery 0.6km north-east of the site and close to the large barrow (Smoothy 1993). Four urned and two un-urned cremations were recorded, one within a pit lined with flints, similar to the cairn within the double ring ditch. Pottery from three of the urns was dated to the middle Bronze Age and the fourth, fragmentary urn possibly to the early Bronze Age. One piece of unburnt human bone was also recorded, suggesting that an inhumation burial was formerly present. These cremations could be peripheral burials directly associated with the nearby Bronze Age barrow.
- 1.4.11 In 2014 an excavation was undertaken at Bata Fields located c 300m north-east of the site. The excavation identified a late Neolithic/early Bronze Age (c

2500-1700 BC) double enclosure consisting of a sub-square annular ditch with a sub-rectangular annexe attached to the west side, together measuring 11m x 15m. A single cremation was found within the sub-rectangular enclosure and was dated to 1750-1530 cal. BC. The enclosures were also associated with trackways, a trampled surface and a six-post building. One of the enclosures contained three small circular ditches (perhaps representing roundhouse gullies). The excavation also recorded a mini barrow (3.5m) of middle Bronze Age date and two further undated and truncated barrows. A middle Bronze Age coaxial field system was also recorded with ditches aligned north-east to south-west (Oxford Archaeology 2016).

- 1.4.12 The cropmarks of two possible ring-ditches are located 0.5km east of the site. These were recorded by the aerial survey and may represent ploughed out round barrows (Aerial Investigations and Mapping Report site 45). These ring ditches are located on the north slopes of a plateau of higher ground overlooking a lower estuarine area to the north. Two perforated whetstones of probable Bronze Age date were found on the plateau, 0.5 and 0.8km east of the site respectively.
- 1.4.13 **Late Bronze Age and Iron Age.** An archaeological evaluation recorded several late Bronze Age features within Land Parcel 135 of the site. One of these features was a NW-SE aligned gully in Trench 136 which contained three sherds of late Bronze Age pottery. The other dated feature in Trench 141 was a posthole containing one sherd of possible late Bronze Age pottery. Several further undated ditches were located in the site. This included a NNE-SSE aligned ditch in Trench 137, a NE-SW ditch in Trench 140 and an E-W ditch and a NW-SE aligned ditch terminus in Trench 148. These undated ditches may have been part of a late Bronze Age field system (Oxford Archaeology 2005).
- 1.4.14 Cropmarks of enclosures, trackways and ring ditches have been recorded on the higher ground at West Tilbury located 0.5km north-west of the site. The aerial survey also recorded a number of field systems and trackways located 0.3km north of Land Parcel 13 (Aerial Investigations and Mapping Report site 43). It is possible that these cropmarks are indicative of late prehistoric or Roman agricultural and domestic activity.
- 1.4.15 The cropmark possible enclosure in Land Parcel 37 was evaluated for the scheme, and produced a very dense area of pits and postholes, many of them late Bronze Age and early Iron Age, but with a second phase of activity of late Iron Age and early Roman date (OCA 2020). Some of the cropmark ditches that appear to enclose this are also dated as Iron Age, although the quantity of finds was small, and these ditches could potentially be later. There was also briquetage and stained burnt areas suggesting that salt production was being carried out in either the Iron Age or Roman periods.
- 1.4.16 Bronze Age and Iron Age activity was recorded by excavation at Gun Hill located 0.8km north-west of the site. A settlement complex was initially identified by cropmarks in the 1950s-1960s and some areas were excavated in 1969-1970. The Bronze Age recorded features included a ditch and postholes and a field system that may have dated to the late Bronze Age/early Iron Age. An Iron Age settlement was recorded with numerous enclosures, ditches, ring ditches, trackways and pits, from which early and middle Iron Age

pottery was recovered. This settlement was located on top of a plateau of higher ground.

- 1.4.17 During the late 1960s a salvage excavation was undertaken west of Princess Margaret Road and just over 1km east of Land Parcel 12. This excavation recorded a sub-rectangular enclosure with a ditch 1.5m wide by 0.76m deep and a number of associated pits. The pottery was dated to the Iron Age and charcoal and animal bones were also found. Cropmarks of a U-shaped enclosure were also recorded just west of this and 0.2km east of the site. The Iron Age enclosure and nearby cropmarks are located on a gravel plateau of higher ground, and two findspots of Iron Age pottery were also recorded on the gravel plateau 800m and 1350m east of the site.
- 1.4.18 **Roman period.** The route of a Roman road is thought to have been located along what is now Princess Margaret Road within the eastern part of the study area. There is no physical evidence for the road itself, but it may have led to a ferry crossing point over the River Thames to Kent. Another possible Roman road was aligned east-west along the Muckingford Road within the northern part of the study area. The archaeological evidence suggests that there were several Roman settlements adjacent to these roads, including a substantial Roman settlement at Mucking located c 2km north-east of the site. Other Roman sites have been recorded on the higher ground within the northern and eastern part of the study area and also within the marshy low-lying areas near the Thames foreshore (discussed below).
- 1.4.19 A geophysical survey and subsequent archaeological evaluation recorded evidence of Roman activity just north-east of the site and undated ditches within Land Parcel 135 of the site. Ditches orientated NW-SE and NE-SW were recorded throughout the evaluation. Undated ditches on this alignment were recorded within Land Parcel 135 of the site. Some ditches were dated as Bronze Age and others on the same alignment as Roman. The HER notes that cropmarks of rectilinear enclosures and pits were recorded just west of the Bata factory and just east of Land Parcel 135. It is therefore possible that the undated features that were found within Land Parcel 135 may be part of a wider complex.
- 1.4.20 The 2005 evaluation also recorded a possible gravel surface, pits and postholes in Trenches 178, 189 and 206 located 0.6km north-east of the site and these may represent a roadway and part of a settlement. The pottery from these features indicated a date range starting in the 1st century and concentrating in the late 2nd and early 3rd centuries (Oxford Archaeology 2005). A rectilinear enclosure, a trackway and a number of pits were recorded 0.6km north-east of the site by the HER and the aerial mapping survey (Aerial Investigation and Mapping Report 39). The evidence from the 2005 evaluation has been compared with evidence from the aerial survey and Trenches 178 and 189 are located in the vicinity of the rectilinear enclosure. This suggests that this enclosure may be of 1st-3rd century AD date. The trackway associated with this enclosure extends north-eastwards within the site and is parallel with Muckingford Road and perpendicular to the East Tilbury Road.
- 1.4.21 As already noted above, pits and postholes of early Roman date were found in Land Parcel 37 adjacent to the site, with possible evidence of salt production. The ditches surrounding these features may also have been

Roman, and further possibly Roman ditches were also found running perpendicular to the possible rectilinear enclosure along the north-east edge of this land parcel (OCA 2020).

- 1.4.22 An early Roman pottery production site and later agricultural settlement was also excavated 0.8km north-west of the site at Gun Hill. This site contained at least three kilns, but a number of others were also destroyed by development. The late Iron Age enclosure mentioned above was used for industrial purposes in the late 1st century AD. There was no evidence for domestic activity and the site reverted to agriculture soon after the 1st century. The possible Roman plough soil did contain some 2nd-3rd century pottery and quern fragments which suggests that there was a middle Roman settlement in the vicinity (Drury and Rodwell 1973).
- 1.4.23 Another Romano British pottery kiln was also identified nearby at West Tilbury, located just north of Land Parcel 13 of the site. In 1986 a rescue excavation of an updraft Roman pottery kiln was undertaken at Condovers disused gravel pit. This pit was located just west of Condovers manor house and just south of Church Road. Condovers gravel pit can be seen on the 1897 OS map although the full extent and depth of the pit is unknown. This pit went out of use in the 20th century and Roman pottery dating to the 2nd century was found in banks of the disused gravel pit. The 2019 aerial survey also noted the presence of a possible circular enclosure in the area of Condovers Pit (Aerial Investigations and Mapping Report site 81). The Pastscape record of the pottery kiln also mentions a circular cropmark and this may have been associated with the kiln. Since the depth of the gravel pit is not recorded it is possible that a circular feature was exposed by the gravel quarrying and captured on an aerial photograph.
- 1.4.24 In 1858 a Roman cremation cemetery was recorded during the construction of the London, Tilbury and Southend Railway. This cemetery was recorded on the northern boundary of Land Parcel 135. Three Roman cremation urns were recorded, and one was gifted to Essex Archaeological Society in c 1863, one to the Colchester Museum and another to the British Museum. The cremation burials were recorded in a valley and adjacent to a north-south stream. In 1910, human burials with iron and bronze bracelets were found at West Tilbury. The exact location of this possible Roman inhumation cemetery is unknown and the four figure reference is recorded as 0.4km west of the site.
- 1.4.25 A number of cropmark sites and findspots have been recorded on the higher ground within the eastern and northern part of the study area. The aerial mapping survey identified a rectangular enclosure located 0.5km north of the site (Aerial Investigations and Mapping Report site 41A). This was recorded in an area where Roman pottery had been found dating to the 2nd century. A possible Roman floor tile was also found nearby and 0.5km north of the site during the LTC walkover. A Roman vase was recorded just east of the possible Roman Road at the eastern edge of the study area.
- 1.4.26 Remains of a Roman settlement located 0.5km south of the site were recorded in 1920. This comprised the well-preserved remains of hut circle and quantities of 1st to 2nd-century pottery, which were found on the southern edge of the marshland, below the present high tide level. A former trackway was also



recorded along the old river edge. Additional finds of Roman pottery have been made on the foreshore in the nearby vicinity.

- 1.4.27 A number of possible saltern sites have been identified within the south-eastern part of the site. Several earthworks that may be salterns were recorded at Bowaters Farm within the eastern part of the site. They were located on the boundary between Land Parcels 38 and 129. The southernmost of these earthworks contained Roman pottery. Pastscape records that three possible salterns were recorded at Bowaters Farm just north of the other saltern, although it is unknown if this is a duplicate record. Another possible saltern site was recorded within Land Parcel 38 as briquetage and Roman pottery sherds were identified in this area. These finds were recorded just north of a possible enclosure that was identified by aerial survey in the south-eastern part of the site (Land Parcels 130 and 38). This possible earthwork enclosure may be associated with creeks on the salt marsh and may be a saltern enclosure. The site was visible with shallow water filled ditches five days after the 1953 flood of this area (Aerial Investigations and Mapping Report site 61). This earthwork enclosure has been levelled but is possible that it exists below ground. Another earthwork was noted during the LTC walkover 0.3km west of the site. It is possible this could be another saltern site or it may be the result of modern drilling activity.
- 1.4.28 A Roman vase was also recorded along the western edge of Land Parcel 12 of the site.
- 1.4.29 A fragment of a Roman lamp with lion relief was found in West Tilbury and the exact location for this find is also unknown.
- 1.4.30 **Medieval period.** Evaluation of Land Parcel 37 on the plateau just outside the site revealed a scatter of probably Saxon features over the north-eastern half of the land parcel including ditches and several large features that were either large pits or sunken-featured buildings. This certainly indicates a focus of early medieval activity, and possibly a settlement with several buildings overlooking the site (OCA 2020).
- 1.4.31 In 1968 a sub-rectangular cropmark was excavated in advance of quarrying at Gun Hill, 0.8km north-west of the site. This was revealed to be an early Saxon sunken-featured building. The pit was outlined with flint nodules which may have been a low wall and three internal postholes were recorded along with a hearth on the floor of the pit. The layers of the pit contained early Anglo-Saxon pottery, possibly of fifth or sixth century date. A number of other pit like cropmarks of similar dimensions were identified from aerial photographs close to Turnpike Lane/Gun Hill and Rectory Road (Drury and Rodwell 1973). These pits have not been excavated but it does suggest there may have been an early Saxon settlement at Gun Hill.
- 1.4.32 During the late Saxon period the site was probably part of one of three manors within the later parishes of East and West Tilbury. Two of these manors had only one smallholder each but the largest manor had one villager, 11 smallholders and two slaves. This larger manor also had 31 cattle, 9 pigs, 260 sheep and 6 plough teams, pasture, woodland and a fishery (Palmer 2019). This indicates a mixed agricultural economy in this area during the late Saxon period. The settlement associated with this larger manor may have been located on the upland plateau area and not the marshland near the Thames

foreshore; the possible early Saxon settlement at Gun Hill may perhaps have continued in use into the middle and late Saxon period. The marshland may have been used for seasonal sheep pasture which is indicated by the large number of sheep and pastureland as noted in the Domesday survey (Darby, 1971, Fig. 63, 241).

- 1.4.33 In the late medieval period, the site was located within the historic parishes of East and West Tilbury. The late medieval settlements were very likely concentrated in located in close proximity to the parish churches of West Tilbury and East Tilbury with a number of dispersed hamlets along major routeways. The possible Roman road through East Tilbury to the Thames foreshore appears to have been an important roadway towards a crossing point over the Thames. Documentary evidence suggests that there was a ferry between East Tilbury and Higham in Kent from the 13th century (Brown and Pattison 2003). Land reclamation may have taken place within during the medieval period within the low-lying marshland towards the River Thames. A possible medieval sea wall is recorded by the Essex HER c 200m south-west of the site. Land reclamation is known to have taken place in the coastal mashes of Essex and the enwalling of the marshes was mostly complete by AD 1500 (Rackham 1980, 106). This would have allowed the marshes to be converted from seasonal pasture into arable use when salinity had reduced.
- 1.4.34 The Church of St James, located 0.3km north-west of the site in West Tilbury, dates from the late 11th or early 12th century. Earthworks located west of this church have been scheduled and this may be the location of the medieval village of West Tilbury. Medieval pottery was found nearby during the excavation of Condovers Pit within the scheme and there may be further medieval activity in this area. It is possible that the medieval settlement of West Tilbury was larger than the modern village. A number of footpaths and tracks around the village may have been former medieval roads. Cooper Shaw Road located just west of Land Parcel 13 may have had Saxon or medieval origins. The hamlet of Low Street located just north-east of Land Parcel 13 may have also had late medieval origins as there is a 15th century house within this settlement, Walnut Tree Cottage, previously known as Condovers.
- 1.4.35 The Church of St Margaret, now renamed as the Church of St Katherine is located 1.3km east of the site. This church dates from the 12th century. Another medieval site was located within East Tilbury, St Mary's Hospital but the precise location is unknown. The HER places this site c 0.4km east of the site but Pastscape places it 0.7km east of the site. Documentary evidence suggests that it was founded in c 1213 and was extant until at least the mid-15th century. As this site was a hospital there may have been an associated graveyard with human burials. Human skulls have been recorded in East Tilbury but the HER only records this as a four figure refence. The skulls may be associated with a cemetery of medieval or earlier date.
- 1.4.36 The cropmark of a ploughed-out windmill was identified west of East Tilbury and 0.8km east of the site which may be medieval in date (Aerial Investigations and Mapping Report site 45).
- 1.4.37 The aerial survey identified a number of possible medieval features to the west of Station Road within Land Parcel 37 adjacent to the site. This included north-west to south-east and north-east to south-west aligned linear features and a

number of discrete features (Aerial Investigation and Mapping Report site 44); these linear features are in alignment and perpendicular to Station Road, which may have originated as a medieval trackway. Trial trenching of Land Parcel 37 has, however, suggested that these features may be of late prehistoric or Roman date, although due to the paucity of finds their dating is not secure. There were, however, certainly medieval ditches and a pit probably of 12th-14th century date in the north-east corner of this land parcel, but the small quantities of finds suggest that these were peripheral to a settlement outside the area of the site (OCA 2020).

- 1.4.38 The southern part of the site comprises a former marshland area and it contains evidence for a number of co-axial ditches and earthworks of north-south aligned trackways. The co-axial field boundaries are former almost certainly field boundary ditches of possible medieval or post-medieval date. A system of drainage would have been essential to use the low-lying area for pasture. The trackways appear as earthworks consisting of ditches on either side of central tracks visible for over 1.5 km. Four of these trackways are visible running in a north-south direction across the former salt marsh and are located within the site (Aerial Investigation and Mapping Report sites 58, 60). It is possible that these tracks were droveways of medieval or post-medieval date. Some of these droveways appeared to start at farms (such as Gravel Pit Farm) or settlements (like Low Street) via green lanes that appear to still be in existence in places, often defined by parallel ditches. These droveways may have been used to take livestock down to the marshes for grazing. A number of these droveways and field boundaries have been levelled by later activity such as Tilbury Power Station and recent landfill sites and a large modern development towards the coast.
- 1.4.39 **Post-medieval period.** During the post-medieval period the site was in use as agricultural land associated with several estates in the parishes of East and West Tilbury. The ownership of the different parts of the site is indicated by the East Tilbury Tithe map of 1839 and the West Tilbury tithe map of 1838. In 1839 the easterly part of the site (Land Parcel 129 and the eastern part of 38) was pastureland owned by Zachariah Piggot. The fields just to the west (Land Parcels 12, 38 and 130) had a number of north-south and east-west field boundaries. These are the same as the boundaries displayed on the 1897 map and are likely to be drainage ditches. Within East Tilbury the easterly of these fields arable and pasture fields owned by the trustees of Frances Georgiana the wife of Edward Henry Moore Kelly of West Tilbury Hall. The westerly of these fields were pasture fields owned by the Rev John Radcliffe of St Annes Limehouse. Land Parcels 135 and 136 were in use as gravel pits associated with Gravel Pit Farm and were owned by Rev Evan Lloyd (rectorial glebe land). Within West Tilbury (the western edge of Land Parcel 12, Land Parcels 13 and 20) these field were mostly pasture and had four different owners. This included the trustees of Frances Georgiana, Samuel Hazard, John Scott and Rev Evan Lloyd. Interestingly the droveways that are shown on both tithe maps are described as manor ways. This suggests that originally each droveway may have belonged to a different manor, perhaps for taking sheep down to pasture or for access to the Thames foreshore.

- 1.4.40 The West Tilbury tithe map of 1838 shows two buildings associated with a trackway and four fields, one of which was called 'Beast House Marsh'. This may be the building described as 'Wick House' located c 200m west of the site in the Essex HER but with no other details. These cottages and the surrounding pasture fields were owned in 1838 by the trustees of Chelmsford Charity. These cottages are shown on the late 19th and early 20th century OS maps but were removed by the 1940s. The exposed position of these cottages in the marshland suggest they were farm cottages, perhaps for tending sheep. The name of one of the fields to the south 'Beast House Marsh' is suggestive of a shelter nearby for livestock.
- 1.4.41 The LTC walkover observed a raised platform earthwork within the western part of Land Parcel 12. This earthwork was situated directly west of a driveway and may be the remains of a building, perhaps another farm cottage. The tithe map and OS maps do not show any buildings at this location, so if this platform did represent a building it is likely to predate the mid-19th century.
- 1.4.42 The Essex HER notes that there may have been a linear series of oyster beds aligned north-south located just east of Land Parcels 130 and 38 of the site. These were observed on aerial photographs dating to 1953 and 1955 and are located 300m inland. This area was inland of the post-medieval sea wall which is shown on the 1777 Chapman and Andre map and so may predate this.
- 1.4.43 Several post-medieval listed buildings are located within the study area and two are located within 200m of the site. This includes the 17th century Polwicks located in Low Street and c 150m west of the site and the 19th century Buckland located 150m north of the site along Station Road. During the LTC walkover the remains of several post-medieval farm buildings were noted in a courtyard arrangement. These were located 100m east of Land Parcel 129 and may be the remains of Bolster Farm shown on late 19th century OS maps.
- 1.4.44 The Tilbury marshes were enwalled in the late medieval period and post-medieval sea defences were created. These earthwork sea defences are likely to have been rebuilt several times. Land Parcels 12 and 130 may contain evidence of former sea defences dating to the medieval and post-medieval period. OS maps reveal that there was a network of drainage ditches in the southern part of the site in the late 19th and early 20th century. The aerial mapping survey recorded a number of former drainage ditches within Land Parcels 12, 130 and 38 (Aerial Investigations and Mapping Report site 34). These drainage ditches have now been removed but may exist below ground.
- 1.4.45 The London, Tilbury and Southend Railway was constructed in the mid-19th century and it is located between Land Parcels 12 and 13 of the site. Low Street railway station was built in 1861 and was located just north of Land Parcel 12 of the site and was associated with this railway. Modern satellite imagery indicates that this station has been demolished. The OS map of 1923 indicates that there were sidings and outbuildings associated with this station. These sidings may have extended into the north-eastern part of Land Parcel 12.
- 1.4.46 During the LTC walkover of this area a series of drainage ditches and earthworks were noted that ran south-westwards from Coalhouse Fort, then

northwards and then westwards before turning southwards back towards the River Thames. The western drainage ditch may form the eastern boundary of a medieval droveway discussed above. The eastern very regular drainage channel was created in the late 20th century. The east-west channel and earthworks are the most interesting of the three and may be of some antiquity (discussed below). This feature was also noted by Pastscape.

- 1.4.47 A sinuous feature or group of features 100m-200m wide and aligned east-west is located just east of Land Parcel 129. This group of features is defined by an earthwork to the north and a drainage ditch to the south. It is possible that this sinuous feature was the course of a former river channel which has now dried up. The further significance of this earthwork is discussed in the undated section below. This sinuous area was known as 'slipes' on the East Tilbury tithe map but the meaning of this is unclear, although it could mean slope. The 'slipes' appear to be associated with a footpath leading west from the church on later post-medieval mapping. The area of the 'slipes' was also subjected to quarrying at the interface between the Thanet Sand and the bedrock chalk as shown on the OS map of c 1897. An area of possible quarrying of the 'slipes' was noted during the LTC walkover and this matches an area of quarrying shown on the 1897 map. This study area and wider vicinity held a strategic position during the post-medieval period as it was located on the north-bank of the River Thames, and only 30km east of London. In 1539-40 five artillery blockhouses were constructed along the Thames including at East Tilbury and West Tilbury on the Essex side of the Thames. In the late 17th century Tilbury coastal fort was constructed on the site of a 16th century blockhouse. In the late 19th century two more forts were constructed in East Tilbury, Coalhouse Fort which was located c 300m north of the East Tilbury blockhouse and
- 1.4.48 **Modern.** The medieval and post-medieval village of East Tilbury originally built up along the Princess Margaret Road towards the ferry crossing point to Kent. In the mid-20th century a new part of the village was constructed 1.7km north-west of the medieval church and just north-east of the site. This part of the village was served by East Tilbury train station which was constructed in the 1930s. The relocation and expansion of the village relates to the Bata Shoe Factory which became a major employer in this area. The estate that grew up around the factory was constructed as a 1930s model settlement. The factory itself is listed as a number of 1930 of houses along Bata Avenue and these are located 0.4-0.6km north-east of the site.
- 1.4.49 The study area contains other examples of other industrial sites including a brickworks and quarry and Tilbury power station. Low Street Brickworks was located just west of Land Parcel 136 of the site, and lay close to several quarries either side of Station Road which predated the brickworks and can be seen on the OS map of 1897. Low Street Brickworks was in operation in the early 1900s and although it shut in the 1920s and 1930s it then reopened until 1967. The brickworks site has been demolished and is now a modern industrial site. Tilbury power station is located 0.4km south-west of the site and is a vast complex which dates to the mid to late 20th century. An electrical substation which is associated with the plant is located just south of Land Parcel 20 and the western part of Land Parcel 12 of the site.

- 1.4.50 East Tilbury and West Tilbury continued to be a heavily defended area (from attack by air, sea and land) in the 20th century due to the strategic location on the Thames. The coastal defences of Tilbury Fort and Coalhouse Fort were both reused during the Second World War but the East Tilbury battery was decommissioned before the First World War. A Second World War radar mast is located within the scheduled area of Coalhouse Fort and formed part of an early warning system of air attack. Several Second World War pillboxes were located on the Thames foreshore located at the southern edge of the study area. There may have only been two along the foreshore but one set has been recorded by the Essex HER and the other set by Pastscape.
- 1.4.51 Another military scheduled site in the study area is the Second World War antiaircraft battery at Bowaters Farm. This is located c 200m east of the site. The aerial survey mapped this site and found that it extended further north-west with associated roads, outbuildings, a magazine and command post (Aerial Investigations and Mapping Report site 46).
- 1.4.52 This area also had a number of fixed Second World War defensive positions including a number of Alan-Williams Steel Turrets, which were located along major roadways. A number of road blocks were also in place but were temporary structures. A large number of anti-glider ditches were located within Land Parcels 12, 130 and 38. These ditches would have prevented gliders landing as part of an invasion force. These anti-glider ditches were recorded by the 2019 aerial investigation and mapping survey and have now been levelled but may exist below ground (Aerial Investigations and Mapping Report site 33).
- 1.4.53 An elongated regular rectangular cropmark feature was noted within Land Parcel 130 during the aerial survey (Aerial Investigations and Mapping Report site 54). This feature is aligned NW-SE and may have been constructed during the Second World War, as it does not appear on late 20th century photographs.
- 1.4.54 The earthworks of a drainage system was recorded by the aerial mapping survey just north of Land Parcel 12 of the site (Aerial Investigations and Mapping Report site 64). This drainage system of ditches was visible on aerial photographs dating from 1940. The ditches were visible on these photographs but have since been destroyed by the construction of a pond and modern drainage system. This system of ditches may have drained into the north-south stream which divides the parishes of East and West Tilbury.
- 1.4.55 Undated features and finds. A number of undated cropmarks have been identified on the higher ground within the study area. These have been discussed above and some of the features may date from the prehistoric or Roman period but there are others like the possible windmill and the field boundaries within the eastern part of the study area that very likely medieval or post-medieval in date.
- 1.4.56 There are a number of undated features within the southern part of the site and the vicinity which historically was an area of reclaimed marshland. This includes possible droveways, two enclosures and a possible house platform. These features are discussed above and are likely to be from a range of dates although the droveways are probably contemporary with reclamation of the marshland in the medieval and post-medieval periods.

1.4.57 As discussed above there is an earthwork of some antiquity located just east of the site. In the HER the earthwork is described as an abrupt partly artificial scarp with a ditch and external rampart which runs west of the church and can be traced for 0.8km. This is known locally as 'Soldier's Graves', which could imply that human bones had been found here. It is possible this earthwork either marks the boundary of an estate or may be the remains of a sea wall.

## 2 Project Aims

---

### 2.1 General aims

2.1.1 The general aims of the project were as follows:

- i. To establish the presence or absence of archaeological remains along the line of the scheme, and the extent of any areas where remains appear likely to be absent.
- ii. In areas where archaeological remains are known or suspected, to clarify the reliability of the cropmark or geophysical survey evidence.
- iii. In areas where no archaeological remains are indicated by aerial or geophysical survey, to clarify whether this apparent absence of remains is genuine.
- iv. To determine the degree of complexity of any surviving horizontal or vertical stratigraphy, and in particular, to investigate areas where topography indicates the likelihood of deep deposit sequences for evidence of buried archaeological horizons and palaeo-environmental sequences.
- v. Where remains are present, to determine the period(s) represented, the extent, state of preservation and character of the archaeological remains.
- vi. To establish the range and state of preservation of archaeological artefacts, and through their recovery and examination, to establish the potential for information about the economy, status and contacts of past inhabitants of the scheme footprint.
- vii. To determine whether palaeo-environmental remains are preserved, and, where these are found, to determine their types (eg charred plant remains, waterlogged remains, molluscan remains), state of preservation and potential for environmental information. This will be achieved through the recovery of samples from sedimentary sequences and archaeological features suitable for assessment of a range of palaeoenvironmental remains (eg charred and waterlogged plant remains, charcoal, insects, pollen, diatoms, ostracods/foraminifera and molluscs) and scientific dating (eg radiocarbon and OSL dating).
- viii. To investigate and record the extent, character and chronology of the sedimentary sequences, in particular those immediately adjacent to and in floodplains, contained within palaeochannels or in dry valleys, and to use the data to refine existing geoarchaeological (predictive) deposit models.
- ix. To place any identified archaeological remains into their local and, where appropriate, regional or national context, and to assess the implications of any such discoveries for our current understanding of settlement and landscape change in the area, including an assessment of the associations of any remains with reference to the historic landscape.
- x. To provide sufficient information to enable the LTC archaeological advisor, in consultation with the Key Archaeological Stakeholders, to determine the significance of the archaeological assets identified within the land parcel.



- xi. To provide a report on the discoveries to inform the Environmental Statement (ES) supporting the Development Consent Order (DCO) and support the preparation of a further archaeological mitigation strategy for the Enabling Works and Construction phases of the scheme.
- xii. Following the DCO, to deposit the report in the public domain, and to generate an accessible and useable archive which will allow future research to be undertaken.

## 2.2 Specific objectives

2.2.1 The specific project objectives were as follows:

- xiii. To conduct the programme of archaeological investigation within the general research parameters and objectives defined by the revised East of England Research Framework (ed. Medlycott 2011), and to take account of the aims and objectives of the Greater Thames Estuary Historic Environment Research Framework.
- xiv. To clarify through targeting of apparently blank areas whether the cropmarks provide an accurate representation of the range, quantity and types of archaeological features present within the parcel.
- xv. To investigate the fringes of the Thames floodplain where the alluvial and organic waterlogged deposits are shallowest, to characterise the environmental sequence here in detail and, where possible, to date it.
- xvi. To investigate the dry valley running into the Thames floodplain from the north, and to establish whether this contains buried archaeological horizons or environment deposits to clarify its past character and development.
- xvii. To investigate whether the fringes of the Thames floodplain formed a focus of past human activity for groups utilising the floodplain, particularly on the western side, and if so, to characterise and date phases of human activity here.
- xviii. On the drier ground, to investigate activity carried out around burial monuments of the Neolithic and early Bronze Age, whether peripheral burial, deposits related to visits, or reuse for burial or other purposes in later periods.
- xix. To look for evidence of early Bronze Age settlement or other activity within the drier northern part of the site.
- xx. To clarify whether the north-eastern part of the site contains late Bronze Age activity as suggested by the 2005 evaluation. If so, to use both artefactual and scientific dating to assist in establishing whether occupation was long-lasting, repeated or shifting.
- xxi. To clarify whether further features of the later prehistoric periods that are not evident from cropmarks survive, as suggested by the finds recovered within the area of WSI R, and in particular, whether there is further evidence of activity connected with Iron Age activity.
- xxii. To establish the extent and character of Roman activity within the area of this WSI, both in relation to evidence for settlement and industrial activity. Three saltern sites have been previously recorded within the eastern side

of the site, and although these are now under historic landfill, there may be further such salterns within the site.

- xxiii. To establish the date of the possible medieval or post-medieval field boundaries, ditches and droveways that have been identified within Land Parcels 12, 38 and 130.
- xxiv. To look for evidence of medieval and post-medieval farmsteads that may have been located along Church Road/Station Road and Cooper Shaw Road in Land Parcels 12, 13 and 136.
- xxv. To determine if any military feature or finds are located within the site (such as defensive ditches) as the wider area contains four scheduled military sites and a number of non-designated military features.

## 3 Methodology

---

### 3.1 Constraints

- 3.1.1 Overhead power lines, other buried services and boreholes were present across the site. There were also ecological constraints that created a buffer along the edge of watercourse at the edges of the fields.
- 3.1.2 These limitations were considered when designing the detailed trench layout, but the plotted positions of buried services are often only approximate, and due to this it was necessary to adjust the locations of several trenches in the field. The final trench layout is shown in Figure 2.

### 3.2 Methodology for the evaluation

- 3.2.1 The total land parcel area available for investigation excluding areas of services, hedgerows and other constraints was 16.53ha. A total of 98 trenches were excavated, each measuring up to 6m wide and 30m in length. One trench measured just 12m x 6m. Combined, these represent a 10% sample of the area available for trenching at ground level. Because the trenches were stepped to allow excavation to a depth of 2m, the area at the base of the trench was reduced and this constituted approximately 3.5% of the available area. The location of the trenches is shown on Figure 2.
- 3.2.2 The trench design was developed to provide an even coverage of the site and provide transects across the underlying deposits. Trenches 3, 6, 9, 10, 12, 14, 15, 16, 17, 25, 26, 28, 35, 39, 43, 44, 46, 47, 48, 62, 70, 71, 74, 78, 85, 89, 93, 98, 99, 100, 101, 102 and 104 were all moved from their original locations to allow for the changes in the constraints. Although this was typically only a few metres in any direction. Trenches 1 and 2 could not be excavated because they were inaccessible. Trenches 4, 42, 77 and 103 were also not excavated because there was insufficient space for them once the other trenches had been relocated and excavated. Whilst the intention was for them to be excavated following the backfilling of other trenches, the weather had deteriorated to a point where this was no longer possible.
- 3.2.3 Where the alluvial sequence was either expected or known to be shallower towards the edge of the floodplain terrace a series of 2-3m deep test pits were planned. In these trenches where the base of the alluvial or peat deposits were not reached at 2m, and following completion of recording and sampling at this horizon, a single bucket width test-pit was to be excavated to 3m deep for one or both ends of the trench. Due to a gradual deterioration in the weather, and consequent Health and Safety concerns, it was only possible to excavate these test-pits at one end of Trenches 9, 18, 21, 23, 27, 34, 92 and 85 to a depth of 3m (see Fig. 9).
- 3.2.4 All trenches were located using a global positioning system (GPS) prior to machine excavation. All trenches were excavated using a tracked excavator fitted with a toothless bucket under constant archaeological supervision.
- 3.2.5 Revealed features were hand cleaned and sampled by hand excavation. They were recorded as outlined within the approved WSI. All finds were bagged by

context throughout the evaluation and were recovered for further investigation, and soil samples were taken as appropriate.

## 4 Results

---

### 4.1 Introduction and presentation of results

- 4.1.1 The results of the evaluation are presented below and include a stratigraphic description of the trenches that contained archaeological remains. The full details of all trenches with dimensions and depths of all deposits can be found in Appendix A. Finds data are tabulated in Appendix B.
- 4.1.2 Context numbers reflect the trench numbers, unless otherwise stated. For example, ditch 3505 is a cut within Trench 35, while stone spread 10106 is a feature within Trench 101.
- 4.1.3 An overview of the results for the site in context is shown on Figure 2. Further detailed plans of the trenches which contained archaeological features are shown on Figures 3-6 and selected sections are shown on Figures 7 and 8. A further site plan showing the location of the 3m test-pits and the geoarchaeological transects is given in Figure 9, and the detailed transects in Figures 10-15.

### 4.2 General soils and ground conditions

- 4.2.1 The soil sequence was relatively consistent across the site with alluvial clay deposits overlain by subsoil and ploughsoil. For the majority of the trenches the natural geology was not reached, even though some of the trenches were excavated in part to a depth of 3m below ground level. A single trench near the northern edge of the site revealed the underlying gravel terrace and a thick layer of peat was also encountered near the base of the investigated sequence in the central northern section of the site.
- 4.2.2 Ground conditions throughout the evaluation were generally good. Despite the majority of trenches being excavated below sea level on an alluvial flood plain, the trenches tended to have only minor problems with groundwater. This was largely due to the clay within the alluvial deposits, which prevented too much groundwater movement. There were however several occasions, increasing in frequency towards the end of the fieldwork, where heavy rainfall led to surface water flooding of the trenches. The trenches in the north of the site that exposed either peat or gravel layers also required daily pumping to allow access to the trench.

### 4.3 General distribution of archaeological deposits

- 4.3.1 Archaeological features were located in Trenches 7, 35, 37, 45, 57, 60, 62, 66, 68, 69 and 101 and mostly comprised field boundary ditches and drainage ditches. Trench 3 revealed a deposit of peat with a layer of waterlogged wood and a small quantity of worked flint, and flint was also recovered from Trench 18, while animal bone was recovered from Trench 70.

### 4.4 Trenches 35 and 37 (Figs 3 and 7)

- 4.4.1 **Trenches 35 and 37** were located in the western field of the three that formed Land Parcel 12. Both trenches revealed the remains of a sinuous drainage ditch marked on the 2nd edition OS Survey Map of 1895 and also evident on

LiDAR mapping of the area (OA 2021, Figs 4b and 7). The ditch (numbered 3505 and 3706) was hand-excavated in Trench 35 and recorded in the section of Trench 37 following truncation by machine (Fig. 7, Section 3700). The ditch was cut from the horizon immediately below the ploughsoil. In Trench 35 the ditch was broadly aligned NE-SW and was 2.94m wide; in Trench 37 it measured up to 3.64m wide and at least 0.6m deep, although the full profile was not recorded. In both trenches the ditch was filled with a naturally accumulated blueish grey silty clay deposit numbered 3506 and 3707. No artefacts were recovered from the feature.

## 4.5 Trenches 57, 62 and 66-70 (Figs 4 and 7)

- 4.5.1 **Trench 57** was positioned at the eastern edge of the central field and revealed an E-W aligned ditch. The full profile of ditch 5705 was recorded in the east facing section of the trench following truncation by the machine during excavation (Fig. 7, Section 5700). It measured 2.9m wide and 0.6m deep and had sloping sides and a broad flattish base that. It was filled with a naturally silted grey brown, silty sandy clay deposit, 5706. Some small fragments of animal bone were recovered from the fill, but no dating evidence was identified. It does however appear to be relatively recent as it was cut through the latest alluvial layer, immediately below the ploughsoil. It also corresponds with a field boundary marked on the 2nd edition OS map.
- 4.5.2 **Trenches 66 and 62** were approximately 40m to the south of Trench 57. They both revealed a small E-W aligned ditch (6206/6607). Excavated and recorded in both trenches it had a slightly irregular profile with steep sides and rounded base (Fig. 7, Sections 6201 and 6600). It measured up to 0.76m wide and at least 0.27m deep and was filled with a grey blue silty clay. A small quantity of animal bone was recovered from the ditch in each of the trenches and a fragment of early post-medieval brick (dated AD 1450-1700) was also found in deposit 6207, the fill of 6206. This ditch is not shown on historic maps, so presumably went out of use earlier.
- 4.5.3 **Trench 68** was located to the southwest of Trench 66 and revealed a large E-W aligned ditch at its southern end. Ditch 6806 measured 2.9m, wide, with steep irregular sides and a concave base 1.08m deep (Fig. 7, Section 6801). Following an initial slump of reddish brown silty clay (6808) down the southern edge of the ditch it was filled with a sequence of naturally silted deposits, 6810, 6809 and 6807. No finds were recovered from the feature but it truncated the latest phase of alluvium directly beneath the ploughsoil and also aligns with a field boundary mapped on the 2nd edition OS map of 1895 (Fig. 4).
- 4.5.4 **Trench 67** lay west of Trench 68 on the southern edge of the site. No archaeological features were found within this trench, but a deep sequence of deposits was recorded (Fig. 8 Section 6700), including an organic horizon (6704) interpreted as a buried soil, a sample of which provided a radiocarbon date of 780-480 cal BC (Beta-614287; 2490 ± 30 BP). This horizon was also seen in all of the adjacent trenches described above and below (see Fig. 14).
- 4.5.5 **Trench 69** was positioned to the east of Trench 68 and revealed a broadly E-W aligned ditch. Ditch 6901 was 0.93m wide with steep sides leading down to a rounded base 0.47m deep (Fig. 7, Section 6900). It was filled with two deposits of naturally accumulated silty clay. The upper fill 6902 contained a

piece of post-medieval tile manufactured between AD 1480 and 1800, but no other finds were recovered. It was cut through the upper alluvial horizon below the ploughsoil, but is not marked on historic maps. It was presumably an earlier version of the parallel boundary marked on 19th century maps and found in Trench 68.

- 4.5.6 **Trench 70** was located east of Trench 69 and south of Trench 62. No continuation of the ditch seen in Trench 69 adjacent was found here, but fragments of animal bone were recovered from layer 7004, a buried soil seen below the overlying sequence of alluvial fills 7001, 7002 and 7003. This was the same buried soil horizon seen and dated in Trench 67.

## 4.6 Trenches 45 and 101 (Figs 5 and 7)

- 4.6.1 **Trench 45** was positioned close to the eastern edge, in the northern half of the central field. Ditch 4501 was E-W aligned and measured 3.7m wide and 0.7m deep with a broad concave profile (Fig. 7, Section 4500; Plate 1). It contained a shallow primary deposit of dark brown silty clay on its northern edge (4502), which was overlain by a sterile natural accumulation of silty clay, (4503). No finds were recovered from the ditch, but it was cut through the upper layer of alluvium, directly beneath the ploughsoil and also matches a field boundary marked on the 2nd edition OS map (Fig. 5).

- 4.6.2 **Trench 101** was positioned on the eastern edge of Land Parcel 12. It revealed a broadly N-S aligned, irregular and unstructured patch of flint stones, 10106 (Plate 2). They covered an area approximately 1.3m across and appeared to have been laid down onto alluvial deposit 10103 with a depth of no more than 0.1m. No cut was identifiable in association with these flints and they were sealed beneath a possible buried soil layer, 10102 at a depth of approximately 1m below ground level. Deposit 10102 was overlain by alluvium 10001 and the ploughsoil. No finds were recovered from amongst the flints, but their stratigraphic position indicates that they predate the drainage ditches recorded elsewhere.

## 4.7 Trenches 3 and 7 (Figs 6 and 8)

- 4.7.1 **Trench 7** was located at the northern edge of Land Parcel 12, and revealed a broadly E-W aligned ditch in section. Ditch 708 measured 2.15m wide and 0.7m deep with a concave profile. It contained a lower fill of blueish grey silty clay (709) overlain by a light greyish brown silty clay deposit (710). No finds were recovered from this feature and it does not match any mapped field boundaries, but it was cut through deposit 703, the upper layer of alluvium.

- 4.7.2 **Trench 3** was situated immediately to the west of Trench 7 at the northern edge of the site. At the base of the trench, at a depth of approximately 2m below ground level (-0.81m OD) was a slightly humic dark grey, fine silty sand (307). The base of this deposit was not revealed, but it measured at least 0.14m thick. It was overlain by a layer of peat (305) that was present along the length of the trench and up to 0.4m thick (Plate 3).

- 4.7.3 In the top of the peat and partially covered by it were numerous large pieces of waterlogged wood including pieces of branch and fragmented bark (Figure 6). The wood appeared to be lying on a predominantly SW-NE orientation, although some pieces were more E-W (Fig. 6). One of the largest pieces of

wood (308) measured 3.6m in length and 0.3m wide (Plate 4). The other pieces were generally shorter in length, having fragmented from larger pieces but the width was generally consistent, between 0.3m and 0.4m. After initial cleaning and recording *in situ*, further examination revealed that the large pieces of wood were lengths of roundwood trunks that had split in half, with the flat horizontal surfaces forming the upper faces (Plate 5). The wood was heavily eroded on its upper surfaces, presumably during exposure before being sealed by alluviation. The wood was examined *in situ* by wood specialist Damian Goodburn for traces of working, and he also observed the underside of two of the largest pieces, but none were found (see Appendix C.3). The identifiable pieces of wood comprised a combination of conifer, alder, ash or oak (*ibid.*).

- 4.7.4 Two pieces of undiagnostic flint debitage and a small spall of burnt flint were recovered from the south-west end of the trench in peat deposit 305. Hard-hammer flaking suggested a date in the late Neolithic or Bronze Age, although this is not certain. A series of radiocarbon dates were therefore obtained from a piece of waterlogged wood from the surface of the peat deposit 305 and from samples of sediments 305 and 307. Due to the lack of well-preserved organic material from sediments 305 and 307, paired dates using the soluble and insoluble fractions of the sediments were produced.
- 4.7.5 The humic silty sand (307) provided a mean date of 2890-2670 cal BC (Beta-614823; 4200 ± 30 BP and Beta-614824; 4190 ± 30 BP), in the late Neolithic period. The peat itself produced a mean date of 2580-2460 cal BC (Beta-614825; 4021 ± 30 BP and Beta-614826; 3940 ± 30 BP). The alder twig from the surface of deposit 305 returned a date of 2030-1780 cal BC (Beta-603775; 3580 ± 30BP). The dates are in stratigraphic sequence, and suggest that the peat accumulated throughout the early Bronze Age.
- 4.7.6 The peat and the waterlogged wood were overlain by successive horizons of alluvium, 304, 303, 302 and 301. These generally comprised silty clay deposits and together totalled a thickness of c 1.8m below the ploughsoil.

## 4.8 Trenches 6, 7, 10, 14 and 18 (Fig 2)

- 4.8.1 This group of trenches were located along the northern edge of the site, close to Trench 3. Each of these trenches revealed layers of peat similar to deposit 305 at the base of the exposed sequences (Plate 6). These waterlogged horizons contained small twigs and brushwood but no larger trunks were present and no worked wood was identified. In each of the trenches the peat deposits were overlain by successive layers of alluvial clay, similar to the sequence in Trench 3.
- 4.8.2 In Trench 18, one of the lower alluvial layers, 1804 (between 0.57m and 1.34m bgl) produced a piece of worked flint. The piece was a broken blade-like flake from bullhead flint in good condition and it is probable that this dates to the Mesolithic/early Neolithic period. Despite this, this piece was probably redeposited as found, as alluvium 1804 is later by several further alluvial deposits than peat 1808, the equivalent layer to which in Trench 3 was dated to the late Neolithic and early Bronze Age. Two further pieces of flint were recovered from the ploughsoil of this trench, but they were abraded and damaged and unlikely to be related to the earlier piece.



## 4.9 Trench 67 (Figs 2 and 8)

- 4.9.1 Trench 67 was situated at the southern edge of the site. Although the trench was devoid of archaeological remains, the sequence of deposits was of interest. At the base of the trench were two thick alluvial layers. Deposit 6706 was approximately 1.65m below ground level, comprising a mid-blue grey, sandy silt alluvium. This was overlain by 6705, a layer of laminated, pale brown silty clay 0.74m thick.
- 4.9.2 Overlying 6705, was probable buried soil horizon, 6704, which consisted of a dark brownish grey, clayey silt. This horizon was also evident in other trenches across this part of the site. An environmental sample taken from this deposit (Sample 21) contained a small fragment of charcoal, which was submitted for radiocarbon dating and produced a date range of 780-510 cal BC (Beta-614827; 2490±30 BP). This deposit must therefore have developed at some point after the early Iron Age.
- 4.9.3 The upper surface of deposit 6704 was approximately 0.9m below ground level and was overlain by three successive layers of clayey silt alluvium: 6703, 6702 and 6701, none of which produced finds.

## 4.10 Finds summary

- 4.10.1 **Ceramic building materials.** Two fragments of CBM were recovered from the site. The assemblage comprised a fragment of medieval/post-medieval brick and a piece of post-medieval peg tile.
- 4.10.2 **Flint.** A very small assemblage of five worked flints and a single fragment of burnt flint was recovered from Trenches 3 and 18. A broken blade-like flake of possible Mesolithic or early Neolithic date from Trench 18 was the only diagnostic piece.

## 4.11 Environmental summary

- 4.11.1 **Charred plant remains and charcoal.** Thirty samples were taken during the evaluation. Four samples were taken for the recovery of Charred Plant Remains (CPR), bones and artefacts, while five samples were taken for the retrieval and assessment of Waterlogged Plant Remains (WPR), insects and Mineralised Plant Remains (MPR), and to establish the potential for preservation of these on site. The remaining samples were taken for OSL dating and soil micromorphology/pollen retrieval. The samples generally contained little identifiable waterlogged plant material although well-humified peaty sediments, of fairly uniform appearance, are represented in samples from a few trenches. The few seeds are well-preserved, indicating that conditions are likely to have remained stable.
- 4.11.2 **Animal bone.** A small quantity of animal bone in fair-good condition was recovered from contexts 4502, 5706, 6207 and 7004. The assemblage comprised the remains of sheep/goat, cattle, horse and pig. The material from Trenches 45, 57 and 62 came from ditches of probably post-medieval date; the only earlier animal bones were those from a cattle scapula from a buried land surface in Trench 70.
- 4.11.3 **Waterlogged wood.** Trench 3 revealed a layer of peat and waterlogged wood. The wood was a combination of split and weathered trunks, bark and

branches. No evidence of toolmarks was present, and the split trunks were thought most likely to have been due to high winds and natural decay. Seventeen pieces of wood were collected from Trench 3 for species identification. Some pieces were too poorly preserved for identification but the remainder were either coniferous, ash, alder or oak, providing some useful information upon the surrounding Bronze Age environment.

## 5 Discussion

---

### 5.1 Reliability of field investigation

- 5.1.1 The layout of trenches provided good overall coverage of the site. However, the need to omit six trenches due restrictions from land access and live services did leave some small areas that could not be investigated. The omission of these trenches is unlikely to have affected to the overall results of the evaluation with a consistent low-level of archaeological remains encountered across the land parcel.
- 5.1.2 The archaeological features were reasonably easy to identify against the underlying alluvium which had otherwise formed a relatively uniform blanket across the entire site. It is therefore unlikely that other features would have been missed or were not easily identified.
- 5.1.3 The most significant limitation of the investigation was the inability to fully examine the full sequence of deposits along the edges of the land parcel, and particularly on the north-west side. The evaluation was never intended to investigate the full depth of the Holocene sequence across all of the floodplain, which boreholes had demonstrated far exceeded the depth to which trenches could be excavated, but the aim was to excavate test-pits within the trench ends to a depth of 3m, which it was believed would enable the exposure of the terrace edge and a sample (albeit limited) of any archaeological horizons overlying it. Only eight trenches (Trenches 9, 18, 21, 23, 27 and 34 on the north-west and Trenches 85 and 92 on the east) were investigated to 3m depth with small test-pits before the weather began to deteriorate and test-pitting to 3m was abandoned). This severely limited the exposure of the gravel terrace and overlying deposits at the north-west edge of the site, and the investigation in detail of deposits such as the peat deposits in the north, only the surface of which was accessible at a depth of 2m.

### 5.2 Interpretation

- 5.2.1 **Mesolithic/Neolithic.** A single blade-like flake recovered from alluvial layer 1804 represents the only Mesolithic or early Neolithic material to be identified on the site. Whilst the piece was in good fresh condition it was discovered in isolation within a 0.77m thick alluvial deposit of blue-grey clay. It is therefore unlikely to represent *in situ* activity at this location, and was almost certainly moved from its original context during one of the many flooding episodes on this floodplain. It need not, however, have travelled far, and may indicate the presence of less disturbed material further to the north at the edge of the floodplain.
- 5.2.2 **Late Neolithic to Bronze Age.** The layer of peat revealed in Trench 3 appears on the evidence from the radiocarbon dating to have begun developing in the late Neolithic and would have been exposed until the start of the middle Bronze Age. Whilst the flint debitage recovered from this deposit was not diagnostic in appearance, the flake was hard-hammer struck, and it is reasonable to assume it was early Bronze Age in date along with the waterlogged pieces of wood.

- 5.2.3 The large waterlogged logs initially gave the impression of forming a timber trackway, similar to that found during excavations at STDR4 in the Ebbsfleet Valley (Stafford 2012). Unfortunately, the eroded upper surfaces retained no evidence of any toolmarks and given the absence of any vertical support pieces driven into the peat, there is no indication that they formed part of a structure, as either a trackway or a platform. It remains possible, however, due to the very eroded condition of those that were examined, that the trunks had been purposively split to form a rough platform, or that naturally split timbers had been brought here deliberately rather than by flooding or natural tree-fall. Even if of entirely natural origin, it is also possible that the resulting wood concentration was made use of by those exploiting the floodplain at the time, as the worked flint fragments suggest. The variety of species present demonstrate the presence of a rich carr-type environment including conifers, alder, oak and ash. Such an environment would have attracted both wildlife and people.
- 5.2.4 Salt production during the late Bronze Age and Iron Age is also well-attested from this section of the Thames estuary and beyond with briquetage fragments recovered during excavations at Mucking (Evans *et al.* 2016), from Land Parcel 6, 2.5km to the north of this site (OCA 2022) and (more immediately relevant) from Land Parcel 37 overlooking the site (OCA 2021). Although no evidence associated with this industry was found in the evaluation, a buried soil horizon was identified within the alluvial sequence that in Trench 67 was radiocarbon-dated to the early Iron Age, and animal bone fragments associated with this horizon were found in Trench 70, suggesting some human activity on the floodplain in late prehistory. An area of flint cobbles was found associated with a buried soil horizon in Trench 101, and if this is the same horizon as that in Trench 67, this hardstanding would also belong to this phase of use of the floodplain. The possibility that salt-working may still be found within the site cannot therefore be ruled out.
- 5.2.5 **Roman and medieval.** No evidence for Roman or medieval salt working was found on the site, nor was evidence of any other activity dating to these periods identified in the trenches.
- 5.2.6 **Post-medieval.** A network of drainage ditches provided almost all the archaeological features recorded by the evaluation. Although artefacts were limited to two pieces of CBM, others matched field boundary ditches marked on 19th century mapping and it seems likely that all of these ditches were established during the post-medieval period. It is unlikely that they had earlier origins as the accumulation of alluvium has shown that they would have been buried relatively quickly.
- 5.2.7 The earliest ditch was possibly that crossing Trenches 62 and 66 which did not appear on historic mapping. Excavation of this yielded a fragment of Tudor type brick. The parallel ditch in adjacent Trench 69 contained a tile fragment that could have been of similar date or later, and is also not shown on historic mapping, so both presumably belong to an earlier pattern of drainage and land division of the floodplain. The drainage of this site was presumably undertaken to facilitate agriculture following reclamation. The other ditches found match those on 19th century historic mapping, and the sinuous ditch crossing Trenches 35 and 37 is also evident on recent LiDAR mapping.

5.2.8 **Undated Features.** The undated spread of flint cobbles recorded in Trench 101 was found at the base of a buried soil horizon, but was not accompanied by any other archaeological features in the trench, or indeed in any of the adjacent trenches associated with this horizon. It is possible that this is the same buried soil that in Trench 67 was radiocarbon dated to the early Iron Age, but this is not certain. Iron Age, Roman, Saxon and medieval remains were recorded on the higher dry ground in Land Parcel 37 to the south-east during evaluation in 2020 (OCA 2021), and the patch of flints in Trench 101 may therefore have formed part of a small area of hard-standing or were laid down as consolidation on a pathway associated with one of these phases of adjacent activity.

### 5.3 Evaluation objectives and results

5.3.1 **Aims i-iii.** This evaluation established that significant archaeological remains are predominantly absent from Land Parcel 12 up to a depth of 2m below ground level. Very few features or finds were recovered from the uppermost buried soil identified across the floodplain. A potential for further horizons at greater depth along the north-west edge of the site was established, but due to the limited depth of excavation these could not be fully exposed or investigated across the site.

5.3.2 Only a few discrete anomalies had been indicated by the geophysical survey and these had no correlating features so are likely to have been caused by interference from agricultural machinery. The blank areas were genuinely determined to be blank with respect to cropmarks and geophysical survey evidence.

5.3.3 **Aim iv.** The evaluation determined the presence of alluvial deposits across the site. The deposits were laid down in a succession of horizontal layers and no complex sequences or structures were identified. One buried soil horizon was identified covering much of the site, and further probable surfaces did survive at the northern edge of the floodplain where the underlying bedrock was shallower.

5.3.4 **Aim v.** The evidence from the evaluation suggests that limited activity was taking place during the Mesolithic/early Neolithic, Bronze Age, Iron Age and post-medieval periods

5.3.5 **Aim vi.** Only a very small number of artefacts were recovered, and these do not provide information about economy, status and contacts of past inhabitants. The waterlogged wood and peat deposits at the northern end of the site demonstrate the potential for organic remains and artefacts to survive on this site.

5.3.6 **Aim vii.** The results have demonstrated a good level of preservation for palaeo-environmental remains, including waterlogged plant remains. The preserved wood found in the peat at the northern end of the site provide information assisting in the reconstruction of the local environment during the early Bronze Age.

5.3.7 **Aim viii.** The upper sedimentary sequences have been traced across the evaluated area, and dates obtained for a phase of peat formation from the late Neolithic to the start of the middle Bronze Age and for a buried soil horizon

elsewhere across the site of the early Iron Age or later. It was not possible to date the cessation of alluviation ie the date of reclamation.

- 5.3.8 **Aim ix.** The geoarchaeological report has considered the information obtained from the evaluation within the context of the wider Thames Estuary.

#### **Specific Objectives**

- 5.3.9 **Aim xiii.** The evaluation was conducted within the parameters and objectives of the revised East of England Research Framework (Medlycott 2011) and takes account of the aims and objectives of the Greater Thames Estuary Historic Environment Research Framework.
- 5.3.10 **Aim xiv.** The absence of cropmark features across Land Parcel 12 does indeed appear to reflect an absence of archaeological features.
- 5.3.11 **Aim xv.** The environmental deposits at the fringe of the floodplain have been investigated, characterised and a start and end date for peat accumulation provided by radiocarbon dating. The latter date also provides a date for the start of alluviation. A horizon within the deeper alluvial sequence further out onto the floodplain has been radiocarbon-dated, but this horizon was not identified along the edge of the floodplain, where no further dates have been obtained for phasing within its accumulation. Neither finds or suitable environmental material for dating were encountered to date the end of alluviation. The quality of the waterlogged environmental remains was not very high, seeds being few and insect remains rare, but pollen is likely to survive, as are ostracods and diatoms.
- 5.3.12 **Aim xvi.** It was not possible to trench the northernmost part of the site, and as a result this objective was not met.
- 5.3.13 **Aim xvii.** Due to the railway line and other services, only limited trenching was possible along the fringe of the floodplain on the north-west. Here gravel was found at relatively shallow depth, indicating a shelf suitable for past human utilisation, but the deposits immediately overlying the gravel were only tested in a few trenches, and no detailed investigation was possible. It is not therefore possible to meet this objective.
- 5.3.14 **Aims xviii-xx.** The areas referenced in these objectives were not investigated during this phase of the fieldwork.
- 5.3.15 **Aim xxi.** The evidence from this evaluation has demonstrated that a buried horizon was present on the Thames floodplain that may be of late prehistoric date, though very few features or other remains have been found accompanying it.
- 5.3.16 **Aim xxii.** No settlement or industrial activity of Roman date was found by the evaluation in the part of Land Parcel 12 that was investigated.
- 5.3.17 **Aims xxiii.** Only a few finds were recovered from the field boundary ditches that were encountered in trenching in Land Parcel 12, but these appear to indicate two phases of post-medieval drainage and land division, the earlier predating the 19th century historic mapping.
- 5.3.18 **Aim xxiv.** No farmsteads of medieval or post-medieval date were identified within the evaluated area.
- 5.3.19 **Aim xxv.** No military features or finds were identified by the evaluation in Land Parcel 12.

## Appendix A Trench Tables

Trench 3							
General description Trench contains ploughsoil covering layers of alluvium. A woody peat deposit with well preserved wood recorded at the base.						Orientation	W-E
						Length (m)	30
						Width (m)	6
						Avg. depth (m)	1.7
Context No.	Type	Fill Of	Width (m)	Depth (m)	Description	Findings	Date
300	Layer			0.3	Ploughsoil. Mid brown grey silty clay. Firm. Very rare pebbles.		
301	Layer			0.33	Alluvial Layer. Light grey silty clay. Firm. Rare pebbles and calcite inclusions. Mottled.		
302	Layer			0.35	Alluvial Layer. Light grey silty clay. Firm and stoneless. Mottled.		
303	Layer			0.55	Alluvial Layer. Mid grey silty clay with common mottling and yellow sulfate mottling.		
304	Layer			0.2	Alluvial Layer. Light blueish grey clay with yellow mottling. Firm.		
305	Layer			0.4	Buried soil. Black humic peat with wood fragments.	Flint	
306	Layer			0.22	Alluvial Layer. Very dark greyish black sandy silt. Humic and soft.		
307	Layer				Alluvial Layer. Dark grey fine silty sand. Loose. Slightly humic.		
308	Fill		0.3		Wooden Object. Potential plank within peat (305). More likely it is tree trunk falling down naturally.		
309	Layer				Other Layer. Gravel. Loose. Recorded in the auger.		
310	Fill		0.38		Wooden Object. Within peat (305)		
311	Fill		0.29		Wooden Object. Potential plank within peat (305). More likely it is a part of tree trunk falling naturally.		
312	Fill		0.72		Wooden Object. Within peat (305).		
313	Fill		0.34		Wooden Object. Within peat (305)		
314	Fill		0.36		Wooden Object. Potential plank within peat (305). More likely, it is part of the tree trunk falling naturally.		
315	Fill		0.46		Wooden Object. Within peat (305).		
316	Fill		0.08		Wooden Object. Tree branch within peat (305).		
317	Fill		0.35		Wooden Object. Potential log within peat (305). More likely, it		

					is part of the tree trunk falling naturally.		
318	Fill		2.5		Wooden Object. Within peat (305)		
319	Fill		0.67		Wooden Object. Tree stump within peat (305).		
320	Fill		0.09		Wooden Object. Within peat (305)		
321	Fill		0.08		Wooden Object. Within peat (305)		
322	Fill		1.3		Wooden Object. Within peat (305)		
323	Fill		2.4		Wooden Object. Within peat (305).		
324	Fill		0.55		Wooden Object. Potential plank within peat (305). More likely, it is part of the tree trunk falling naturally.		
325	Fill		0.46		Wooden Object. Within peat (305)		
326	Group				Wooden Object. Within peat (305). Shot numbers 719-753.		
327	Fill		0.4		Wooden Object. Within peat (305)		
328	Layer			0.11	Buried soil. Mid to light yellowish brown silty peat deposit. Overlies wooden object 308. Not present in section 300. Overlies peat 305 and wooden objects / logs		
329	Layer			0.21	Natural. Soft, dark greenish grey fine to medium sand, well sorted. Possible fluvial sand.		

#### Trench 4

General description						Orientation	
						Length (m)	
						Width (m)	
						Avg. depth (m)	
Context No.	Type	Fill Of	Width (m)	Depth (m)	Description	Finds	Date

#### Trench 5

General description						Orientation		NW-SE
Trench devoid of archaeology. Consists of ploughsoil overlying alluvial deposits that cover a buried soil horizon. This overlies further alluvial deposits. Peat identified in auger at 3m BGL						Length (m)		30
						Width (m)		6
						Avg. depth (m)		2
Context No.	Type	Fill Of	Width (m)	Depth (m)	Description	Finds	Date	
500	Layer			0.3	Ploughsoil. Dark brownish grey compact silty clay			
501	Layer			0.29	Alluvial Layer. Light grey clay silt, overlies alluvial layer (502).			



502	Layer			0.27	Alluvial Layer. Mid grey brown clay silt, overlies buried soil layer (503).		
503	Layer			0.16	Buried soil. Dark grey brown silt clay, overlies alluvial layer (504).		
504	Layer			0.34	Alluvial Layer. Mid grey brown clay silt, overlies alluvial layer (505).		
505	Layer			0.38	Alluvial Layer. Light grey clay silt, overlies alluvial layer (506).		
506	Layer			0.1	Alluvial Layer. Grey silty clay. Soft. Common black humic inclusions. Overlies buried soil layer (507).		
507	Layer			0.1	Buried soil. Reddish brown fibrous peat, overlies buried soil layer (508).		
508	Layer			0.3	Buried soil. Reddish brown silt with common fibrous plant fragments. Soft. Overlies buried soil layer (509).		
509	Layer			0.4	Buried soil. Black humic sandy silt. Plant fragments recorded.		
510	Layer			0.25	Other Layer. Green grey sand. Soft.		
511	Layer				Other Layer. Greenish grey sand with rounded gravel. Loose.		

#### Trench 6

General description						Orientation	N-S
Trench devoid of archaeology. Consists of ploughsoil overlying alluvial deposits that cover a buried soil horizon. This overlies further alluvial deposits which overlie a thin peat deposit. This sits above sand and sandy gravel deposits						Length (m)	30
						Width (m)	6
						Avg. depth (m)	2
Context No.	Type	Fill Of	Width (m)	Depth (m)	Description	Finds	Date
600	Layer			0.3	Ploughsoil. Dark greyish brown clayey silt.		
601	Layer			0.1	Alluvial Layer. Light bluish grey clayey silt, overlies alluvial layer (602).		
602	Layer			0.18	Alluvial Layer. Light bluish grey clayey silt with abundant iron mottling. Overlies alluvial layer (603).		
603	Layer			0.1	Alluvial Layer. Light bluish silty clay, overlies buried soil layer (604).		
604	Layer			0.19	Buried soil. Dark brownish grey clayey silt, overlies alluvial layer (605).		
605	Layer			0.35	Alluvial Layer. Mid bluish grey silty clay, overlies alluvial layer (606).		
606	Layer			0.3	Alluvial Layer. Mid yellowish brown silty clay, overlies alluvial layer (607).		

607	Layer			0.11	Alluvial Layer. Mid bluish grey silty clay, overlies buried soil layer (608).		
608	Layer			0.06	Buried soil. Dark yellowish brown sandy peat, overlies layer (609).		
609	Layer			0.54	Other Layer. Pale bluish grey slightly clayey fine to medium sand. Overlies layer (610).		
610	Layer				Other Layer. Pale grey fine to medium sandy gravel. Possible terrace gravel		

### Trench 7

General description						Orientation	SE-NW
Trench consists of ploughsoil overlying alluvial deposits that cover a buried soil horizon. This overlies further alluvial deposits which overlie wood peat in the base of the trench						Length (m)	30
						Width (m)	6
						Avg. depth (m)	2
Context No.	Type	Fill Of	Width (m)	Depth (m)	Description	Finds	Date
700	Layer			0.22	Ploughsoil. Dark greyish brown clayey silt		
701	Layer			0.18	Alluvial Layer. Mid brown grey with light grey and dark grey brown clay silt.		
702	Layer			0.22	Alluvial Layer. Mid grey clay silt with light grey mottling. Rare patches of fine light white yellow sand. Iron staining.		
703	Layer			0.76	Alluvial Layer. Mid brown silt clay with veins of mid blue grey silt. Iron stained.		
704	Layer			1.44	Alluvial Layer. Mid blue grey silt clay. Iron staining.		
705	Layer			0.75	Alluvial Layer. Dark brown peat.		
706	Layer			0.28	Alluvial Layer. Light blue grey silt sand.		
707	Layer				Alluvial Layer. Gravel layer. Context not observed but depth where auger was refused. Sounded and felt like gravel and this is consistent with nearby trenches.		
708	Cut		2.15	0.7	Ditch		
709	Fill	708	1.94	0.37	Tertiary Fill. Mid blue-grey clay, very compact		
710	Fill	708	2.15	0.33	Tertiary Fill. Light grey yellow clay with orange mottling		

### Trench 8

General description						Orientation	N-S
Trench devoid of archaeology. Consists of ploughsoil and subsoil overlying a deep sequence of alluvial layers.						Length (m)	30
						Width (m)	6
						Avg. depth (m)	2

Context No.	Type	Fill Of	Width (m)	Depth (m)	Description	Finds	Date
800	Layer			0.3	Ploughsoil. Dark greyish brown clayey silt, firm, occasional small rounded pebbles and sub-angular flint fragments.		
801	Layer			0.2	Subsoil. Dark grey silty clay, firm with frequent chalk flecks.		
802	Layer			0.3	Alluvial Layer. Light grey silty clay with common pale yellowish mottling, firm. Overlies alluvial layer (803).		
803	Layer			0.33	Alluvial Layer. Mid brownish grey silty clay with reddish mottling, firm and stoneless. Overlies alluvial layer (804).		
804	Layer			0.4	Alluvial Layer. Mid grey silty clay with common mottling, soft and stoneless. Overlies alluvial layer (805).		
805	Layer			0.5	Alluvial Layer. Mid bluish grey silty clay with organic material, soft and stoneless.		
<b>Trench 9</b>							
General description					Orientation	N - S	
Trench devoid of archaeology. Consists of ploughsoil overlying alluvial layers which overlie sandy river terrace gravel. Test pit to 3m excavated at north end of trench					Length (m)	30	
					Width (m)	2.1	
					Avg. depth (m)	1.5	
Context No.	Type	Fill Of	Width (m)	Depth (m)	Description	Finds	Date
900	Layer			0.27	Ploughsoil. Dark brown grey clay silt. Firm, stiff. Inclusions: frequent organic material - 5% infrequent iron - 5% infrequent manganese 5% unstratified, unsorted, some flint pebbles <1%, <20mm, some chalk pieces - SA - <1% <20mm. Sharp boundary with lower context. Ploughsoil.		
901	Layer			0.09	Alluvial Layer. Mid blue grey sandy clay. Firm, not stiff. Inclusions: frequent organic material - 10%, frequent iron - 10%, frequent manganese. Bioturbation throughout. Unstratified, unsorted. Some SR flint pebbles - <1%, <20mm. Wavy boundary with lower context. Subsoil/alluvium. Overlies alluvial layer (902).		
902	Layer			0.19	Alluvial Layer. Dark blue grey silty clay. Firm, stiff. Inclusions: rare manganese -1%, infrequent organic material 5%, very frequent iron 15%. Significant iron stains. Unstratified,		

					unsorted. Stoneless. Wavy boundary with lower context. Alluvium. Overlies alluvial layer (903).		
903	Layer			0.77	Alluvial Layer. Dark blue grey brown silt clay with frequent orange mottling. Inclusions: infrequent manganese 5%, rare calcified deposits 1%, infrequent organic material 5%, very frequent iron staining 15%. Stiff, firm. Unstratified, unsorted, stoneless. Defined boundary with low context. Overlies layer (904).		
904	Layer			0.5	Other Layer. Light white grey silt sand with patches of iron staining and mid grey patches. Inclusions: frequent iron 15%, frequent organic material. Very frequent iron staining. Top 0.1m of deposit much more sandy, base of deposit comes on to iron-rich sand. Gravel - SA/SR flint pebbles <40mm, 20%. Loose, non-stiff. Defined boundary with lower context. Pleistocene gravel. Overlies alluvial layer (905).		
905	Layer			0.17	Alluvial Layer. Mid grey brown clay silt. 20% SA/SR <40mm flint gravel. Fluvial? Overlies buried soil layer (906).		
906	Layer				Buried soil. Mid brown yellow sand gravel with patches of light grey and mid brown yellow sand. Terrace gravel.		
<b>Trench 10</b>							
General description						Orientation	NE-SW
Trench devoid of archaeology. Consisting of ploughsoil and subsoil covering sequence of alluvial layers. Peat identified beneath alluvium at 1.7m BGL						Length (m)	30
						Width (m)	6
						Avg. depth (m)	2
Context No.	Type	Fill Of	Width (m)	Depth (m)	Description	Finds	Date
1000	Layer			0.2	Ploughsoil. Dark greyish brown clayey silt.		
1001	Layer			0.33	Alluvial Layer. Mid grey clayey silt with reddish brown mottling, overlies buried soil layer (1002).		
1002	Layer			0.05	Buried soil. Dark grey clayey silt with iron inclusions, overlies alluvial layer (1003).		
1003	Layer			0.25	Alluvial Layer. Mid grey clayey silt with reddish brown veins, overlies alluvial layer (1004).		
1004	Layer			0.67	Alluvial Layer. Mid brownish grey clayey silt, reddish brown		

					veins, overlies alluvial layer (1005).		
1005	Layer			0.32	Alluvial Layer. Mid bluish grey clayey silt, reddish brown veins. Overlies buried soil layer (1006).		
1006	Layer			0.19	Buried soil. Peat layer, dark yellowish brown. Stoneless with frequent organic remains. Overlies alluvial layer (1007).		
1007	Layer			0.29	Alluvial Layer. Mid bluish grey silty sand, overlies layer (1008).		
1008	Layer				Other Layer. Sandy gravel. Not retrieved in auger		

### Trench 11

General description						Orientation	NE-SW
Trench devoid of archaeology. Consists of ploughsoil overlying a sequence of deep alluvial layers.						Length (m)	12
						Width (m)	6
						Avg. depth (m)	2
Context No.	Type	Fill Of	Width (m)	Depth (m)	Description	Finds	Date
1100	Layer			0.3	Ploughsoil. Dark greyish brown clayey silt, firm with small rounded pebbles and sub-angular flint fragments.		
1101	Layer			0.4	Alluvial Layer. Light grey silty clay with common pale yellowish mottling, firm. Overlies alluvial layer (1102).		
1102	Layer			0.15	Alluvial Layer. Dark grey silty clay, firm, stoneless. Overlies alluvial layer (1103).		
1103	Layer			0.35	Alluvial Layer. Mid brownish grey silty clay with reddish mottling, firm and stoneless. Overlies alluvial layer (1104).		
1104	Layer			0.4	Alluvial Layer. Mid bluish grey silty clay with organic material, soft and stoneless.		

### Trench 12

General description						Orientation	NE - SW
Trench devoid of archaeology. Consists of ploughsoil overlying alluvium that covers a buried soil horizon. This overlies further alluvial deposits. Peat recorded in auger at 1.7m BGL						Length (m)	30
						Width (m)	6
						Avg. depth (m)	2
Context No.	Type	Fill Of	Width (m)	Depth (m)	Description	Finds	Date
1200	Layer			0.32	Ploughsoil. Very dark greyish brown clay/silt (prismatic when dry). Firm. Very rare small pebbles and chalk <2% 20mm. Sharp transition.		
1201	Layer			0.23	Alluvial Layer. Mid grey silt/clay. Firm. Rare (<5%) chalk inclusions and small rounded		

					pebbles (<20mm). Manganese staining (<2%). Rootless. Gradual transition. Overlies alluvial layer (1202).		
1202	Layer			0.22	Alluvial Layer. Mid grey silt clay. Oxidised. Deep channels filled with oxides and small stones. Firm. Sharp transition. Overlies buried soil layer (1203).		
1203	Layer			0.13	Buried soil. Dark grey clayey silt (higher silt content than 1202). Firm, porous. Some pores filled with iron oxides (root replacement). Overlies alluvial layer (1204).		
1204	Layer			0.55	Alluvial Layer. Mid grey clay/silt. Oxidised. Occasionally (<5%). Dark red iron nodules (iron root replacement common). Firm. Stoneless. Overlies alluvial layer (1205).		
1205	Layer		0.25		Alluvial Layer. Mid blueish grey clayey silt. Firm (sticky) black organic detritus. Yellowish mottling (fills of voids/features). Overlies buried soil layer (1206).		
1206	Layer			0.8	Buried soil. Dark yellow brown peat, overlies alluvial layer (1207).		
1207	Layer			0.25	Alluvial Layer. Mid blue grey clay silt sand with detrital organic material. Overlies alluvial layer (1208).		
1208	Layer			0.25	Alluvial Layer. Mid blue grey clay silt sand with flint gravel.		

### Trench 13

General description

Orientation

N-S

Trench devoid of archaeology. Consists of ploughsoil covering a sequence of alluvial layers. Peat recorded at 2.5m BGL

Length (m)

30

Width (m)

6

Avg. depth (m)

2

Context No.	Type	Fill Of	Width (m)	Depth (m)	Description	Finds	Date
1300	Layer			0.27	Ploughsoil. Dark brown grey clay silt.		
1301	Layer			0.39	Alluvial Layer. Mid brown grey silt clay with mid grey and mid brown mottling. Overlies colluvial layer (1302).		
1302	Layer			0.34	Colluvial Layer. Mid grey clay silt with mid brown mottling. Overlies alluvial layer (1303).		
1303	Layer			0.38	Alluvial Layer. Mid brown clay silt, overlies alluvial layer (1304).		
1304	Layer			0.37	Alluvial Layer. Light grey brown clay silt, overlies alluvial layer (1305).		

1305	Layer				Alluvial Layer. Mid blue grey clay silt. Significant organic remains. Detrital clay. Overlies buried soil (1307).		
1306	Fill		0.22	0.87	Wooden Object. Preserved wooden timber located within trench section		
1307	Layer			0.52	Buried soil. Dark brown fibrous, spongy peat with wood fragments. Overlies buried soil (1308).		
1308	Layer			0.36	Buried soil. Dark reddish brown organic silt with common sand. Peat, overlies gravel layer (1309).		
1309	Layer				Other Layer. Gravel		
<b>Trench 14</b>							
General description						Orientation	N-S
Trench consists of ploughsoil overlying alluvial layers which cover a peat deposit to the southern half of trench. This peat overlies sandy gravel possible terrace deposits.						Length (m)	30
						Width (m)	6
						Avg. depth (m)	2
Context No.	Type	Fill Of	Width (m)	Depth (m)	Description	Finds	Date
1400	Layer			0.23	Ploughsoil. Dark greyish brown ploughsoil		
1401	Layer			0.09	Alluvial Layer. Mid yellowish grey, overlies alluvial layer (1402).		
1402	Layer			0.42	Alluvial Layer. Mid to light blueish grey silty clay. Overlies alluvial layer (1403).		
1403	Layer			0.41	Alluvial Layer. Mid grey silty clay, overlies alluvial layer (1404).		
1404	Layer			0.66	Alluvial Layer. Mid yellowish brown silty clay Rare detrital organic matter Alluvium. Overlies alluvial layer (1405).		
1405	Layer			0.2	Alluvial Layer. Mid yellowish brown silty clay Infrequent small to large pebbles. Overlies alluvial layer (1406).		
1406	Layer			0.36	Alluvial Layer. Soft dark bluish silty clay with frequent detrital organic matter. Overlies buried soil (1407).		
1407	Layer				Buried soil. Very dark yellowish brown silt Peat, overlies layer (1408).		
1408	Layer				Other Layer. Light white yellow sand. Possible terrace gravel. Overlies alluvial layer (1409).		
1409	Layer				Alluvial Layer. Mid yellow orange gravel.		

Trench 15							
General description						Orientation	
Trench devoid of archaeology. Consists of ploughsoil overlying a sequence of alluvial layers.						Length (m)	30
						Width (m)	6
						Avg. depth (m)	2
Context No.	Type	Fill Of	Width (m)	Depth (m)	Description	Finds	Date
1500	Layer				Ploughsoil. Dark greyey brown clayey silt.		
1501	Layer			0.2	Alluvial Layer. Lightgrey silty clay with common pale yellowish mottling. Firm and stoneless. Overlies alluvial layer (1502).		
1502	Layer			0.18	Alluvial Layer. Mid grey silty clay with reddish mottling. Find and stoneless. Overlies alluvial layer (1503).		
1503	Layer			0.83	Alluvial Layer. Mid grey silty clay with common mottling. Firm and stoneless. Overlies alluvial layer (1504).		
1504	Layer			0.4	Alluvial Layer. Mid grey clay silt. Rare mottling. Firm and stoneless. Overlies alluvial layer (1505).		
1505	Layer				Alluvial Layer. Mid blue grey clay silt with black organic detritus. Stoneless and firm.		
Trench 16							
General description						Orientation	E-W
Trench devoid of archaeology. Consists of ploughsoil overlying alluvial deposits, which cover a buried soil. This overlies further alluvial layers, the lowest of which contains detrital organic material						Length (m)	30
						Width (m)	6
						Avg. depth (m)	2
Context No.	Type	Fill Of	Width (m)	Depth (m)	Description	Finds	Date
1600	Layer			0.28	Ploughsoil. Dark greyish brown clayey silt		
1601	Layer			0.27	Alluvial Layer. Mid brownish grey clayey silt, overlies alluvial layer (1602).		
1602	Layer			0.12	Alluvial Layer. Mid olive brown silty clay, overlies buried soil (1603).		
1603	Layer			0.19	Buried soil. Dark greyish brown clayey silt, overlies alluvial layer (1604).		
1604	Layer			0.68	Alluvial Layer. Mid yellowish brown silty clay, overlies alluvial layer (1605).		
1605	Layer			0.33	Alluvial Layer. Mid greyish brown silty clay, overlies alluvial layer (1606).		
1606	Layer			0.97	Alluvial Layer. Soft, mid to light blueish grey silty clay with frequent detrital organic		



					material. Overlies alluvial layer (1607).		
1607	Layer			1.73	Alluvial Layer. Soft, mid to light blueish grey silty clay. Overlies alluvial layer (1608).		
1608	Layer				Alluvial Layer. Firm, mid blueish grey silty clay with irregular bands of dark greyish brown organic matter		
<b>Trench 17</b>							
General description						Orientation	E-W
Trench devoid of archaeology and consists of ploughsoil overlying alluvial deposits which cover a buried soil horizon. This overlies more alluvial deposits						Length (m)	30
						Width (m)	6
						Avg. depth (m)	2
Context No.	Type	Fill Of	Width (m)	Depth (m)	Description	Finds	Date
1700	Layer			0.28	Ploughsoil. Dark greyish brown clayey silt		
1701	Layer			0.1	Alluvial Layer. Mid yellowish brown clayey silt. Oxidised alluvium. Overlies alluvial layer (1702).		
1702	Layer			0.45	Alluvial Layer. Mid blueish grey silty clay, overlies buried soil (1703).		
1703	Layer			0.14	Buried soil. Dark greyish brown clayey silt, overlies alluvial layer (1704).		
1704	Layer			0.4	Alluvial Layer. Mid yellowish brown silty clay, overlies alluvial layer (1705).		
1705	Layer			0.46	Alluvial Layer. Mid greyish brown silty clay, overlies alluvial layer (1706).		
1706	Layer				Alluvial Layer. Soft, mid to light blueish grey silty clay with frequent detrital organic material		
<b>Trench 18</b>							
General description						Orientation	NNW-SSE
Trench devoid of archaeology. Consisting of ploughsoil covering sequence of alluvial layers. Peat recorded in auger at 3.9m BGL. Test pit to 3m excavated to north end of trench.						Length (m)	30
						Width (m)	6
						Avg. depth (m)	2
Context No.	Type	Fill Of	Width (m)	Depth (m)	Description	Finds	Date
1800	Layer			0.29	Ploughsoil. Dark greyish brown silty clay, firm compaction.	Flint	
1801	Layer			0.14	Alluvial Layer. Light greyish brown silty clay, firm compaction. Overlies alluvial layer (1802).		
1802	Layer			0.26	Alluvial Layer. Light greyish brown silty clay firm compaction. Frequent chalk inclusions, root		

					structure, manganese and lamination. Overlies alluvial layer (1803).		
1803	Layer			0.17	Alluvial Layer. Dark grey, silty clay, firm compaction. Silty inclusion. Overlies alluvial layer (1804).		
1804	Layer			0.77	Alluvial Layer. Light greyish brown silty clay, firm compaction. Oxidised root structures. Overlies alluvial layer (1805).	Flint	Meso/E. Neo
1805	Layer			0.2	Alluvial Layer. Mid bluish grey clay, firm compaction, black organic inclusions. Overlies alluvial layer (1806).		
1806	Layer			0.77	Alluvial Layer. Light greyish brown (oxidised) silty clay, firm, non-porous (massive) Very common reddish mottling from oxide Stoneless Clear boundary. Overlies alluvial layer (1807).		
1807	Layer			0.95	Alluvial Layer. Light grey clayey silt. Soft. Overlies buried soil (1808).		
1808	Layer				Buried soil. Dark reddish brown fibrous peat.		

#### Trench 19

##### General description

Trench devoid of archaeology. Consists of ploughsoil overlying alluvial deposits, which cover a buried soil. This overlies further alluvial layers, the lowest of which contains detrital organic material.

##### Orientation

N-S

##### Length (m)

30

##### Width (m)

6

##### Avg. depth (m)

2

Context No.	Type	Fill Of	Width (m)	Depth (m)	Description	Finds	Date
1900	Layer			0.34	Ploughsoil. Dark greyish brown clayey silt		
1901	Layer			0.14	Alluvial Layer. Mid brownish grey clayey silt. Overlies alluvial layer (1902).		
1902	Layer			0.38	Alluvial Layer. Mid blueish grey silty clay. Overlies buried soil (1903).		
1903	Layer			0.16	Buried soil. Dark greyish brown clayey silt. Overlies alluvial layer (1904).		
1904	Layer			0.44	Alluvial Layer. Mid yellowish brown silty clay. Overlies alluvial layer (1905).		
1905	Layer			0.42	Alluvial Layer. Mid greyish brown silty clay. Overlies alluvial layer (1906).		
1906	Layer				Alluvial Layer. Soft, mid yo light blueish grey silty clay with frequent detrital organic matter		

#### Trench 20

General description						Orientation	SW - NE
Trench devoid of archaeology. Consists of ploughsoil overlying a sequence of alluvial deposits and organic buried soil between these.						Length (m)	30
						Width (m)	6
						Avg. depth (m)	2
Context No.	Type	Fill Of	Width (m)	Depth (m)	Description	Finds	Date
2000	Layer			0.2	Ploughsoil. Dark greyish brown clayey silt, firm.		
2001	Layer			0.37	Alluvial Layer. Light grey silty clay with orangish and yellowish mottling, firm. Overlies alluvial layer (2002).		
2002	Layer			0.25	Alluvial Layer. Mid brownish grey with yellowish mottling silty clay, firm, stoneless. Overlies alluvial layer (2003).		
2003	Layer			0.55	Alluvial Layer. Mid grey silty clay with common mottling, soft. Overlies alluvial layer (2004).		
2004	Layer			0.7	Alluvial Layer. Mid bluish grey silty clay with organic material, soft and stoneless.		
<b>Trench 21</b>							
General description						Orientation	NE-SW
Trench devoid of archaeology. Consists of ploughsoil overlying a sequence of alluvial deposits and organic buried soil between these. Test pit to 3m excavated to north-east end of trench.						Length (m)	30
						Width (m)	6
						Avg. depth (m)	3
Context No.	Type	Fill Of	Width (m)	Depth (m)	Description	Finds	Date
2100	Layer			0.27	Ploughsoil. Dark greyish brown clayey silt, firm.		
2101	Layer			0.37	Alluvial Layer. Mid grey silty clay with orangish mottling, firm and stoneless. Overlies alluvial layer (2102).		
2102	Layer			0.25	Alluvial Layer. Mid grey silty clay with occasional mottling, firm. Overlies buried soil (2103).		
2103	Layer			0.09	Buried soil. Black humic clayey silt, soft. Overlies alluvial layer (2104).		
2104	Layer			0.58	Alluvial Layer. Mid grey silty clay with common mottling, soft and stoneless. Overlies alluvial layer (2105).		
2105	Layer			0.5	Alluvial Layer. Mid bluish grey silty clay with organic material, soft and stoneless. Overlies alluvial layer (2106).		
2106	Layer				Alluvial Layer. Mid blue grey silt clay with infrequent organic material.		
<b>Trench 22</b>							

General description						Orientation	E-W
Trench devoid of archaeology. Consists of ploughsoil overlying a deep sequence of alluvial layers.						Length (m)	22
						Width (m)	6
						Avg. depth (m)	2
Context No.	Type	Fill Of	Width (m)	Depth (m)	Description	Finds	Date
2200	Layer			0.3	Ploughsoil. Dark greyish brown clayey silt, firm. Overlies (2201)		
2201	Layer			0.42	Alluvial Layer. Light grey silty clay with frequent orangish mottling, firm. Overlies alluvial layer (2202).		
2202	Layer			0.45	Alluvial Layer. Mid brownish grey silty clay with occasional reddish mottling. Overlies (2203)		
2203	Layer			0.44	Alluvial Layer. Mid grey silty clay with common mottling, soft and stoneless. Overlies (2204)		
2204	Layer			0.35	Alluvial Layer. Mid bluish grey silty clay with organic material, soft and stoneless.		
<b>Trench 23</b>							
General description						Orientation	NE-SW
Trench devoid of archaeology. Consists of ploughsoil overlying deep sequence of alluvial layers and organic buried soil between these. Test pit to 3m excavated to north-east end of trench.						Length (m)	30
						Width (m)	6
						Avg. depth (m)	3
Context No.	Type	Fill Of	Width (m)	Depth (m)	Description	Finds	Date
2300	Layer			0.25	Ploughsoil. Dark greyish brown clayey silt, firm. Overlies (2301)		
2301	Layer			0.48	Alluvial Layer. Light grey silty clay with common pale yellowish and orangish mottling, firm. Overlies (2302)		
2302	Layer			0.25	Alluvial Layer. Mid brownish grey silty clay with occasional reddish mottling, firm and stoneless. Overlies (2303)		
2303	Layer			0.1	Buried soil. Black humic clayey silt, soft. Overlies (2304)		
2304	Layer			0.6	Alluvial Layer. Mid grey silty clay with common mottling, soft and stoneless. Overlies (2305)		
2305	Layer			0.95	Alluvial Layer. Mid bluish grey silty clay with organic material, soft and stoneless. Overlies (2306)		
2306	Layer			0.4	Alluvial Layer. Mid/dark blue grey sand clay with detrital organic material.		
<b>Trench 24</b>							
General description						Orientation	E-W
						Length (m)	30

Trench devoid of archaeology. Consists of ploughsoil overlying deep sequence of alluvial deposits and organic buried soil between these.						Width (m)	6
						Avg. depth (m)	2
Context No.	Type	Fill Of	Width (m)	Depth (m)	Description	Finds	Date
2400	Layer			0.3	Ploughsoil. Dark greyish brown clayey silt, firm. Overlies (2401)		
2401	Layer			0.4	Alluvial Layer. Light grey silty clay with frequent yellowish mottling, firm. Overlies (2402)		
2402	Layer			0.2	Alluvial Layer. Mid greyish brown silty clay with occasional mottling, firm. Overlies (2403)		
2403	Layer			0.12	Buried soil. Black humic clayey silt, soft. Overlies (2404)		
2404	Layer			0.65	Alluvial Layer. Mid grey silty clay with common mottling, soft. Overlies (2405)		
2405	Layer			0.45	Alluvial Layer. Mid bluish grey silty clay with organic material, soft and stoneless.		
<b>Trench 25</b>							
General description						Orientation	NE-SW
Trench devoid of archaeology. Consists of ploughsoil overlying a deep sequence of alluvial layers and a buried soil.						Length (m)	30
						Width (m)	6
						Avg. depth (m)	2
Context No.	Type	Fill Of	Width (m)	Depth (m)	Description	Finds	Date
2500	Layer				Ploughsoil. Dark greyish brown fine-grained clayey silt.		
2501	Layer				Alluvial Layer. Light brown silty clay. Overlies alluvial layer (2502).		
2502	Layer				Alluvial Layer. Mid brownish grey silty clay. Overlies buried soil (2503).		
2503	Layer				Buried soil. Dark brown humic clayey silt. Overlies alluvial layer (2504).		
2504	Layer				Alluvial Layer. Mid grey silty clay with yellowish mottling. Overlies alluvial layer (2505).		
2505	Layer				Alluvial Layer. Mid bluish grey silty clay with organic material.		
<b>Trench 26</b>							
General description						Orientation	SW - NE
Trench devoid of archaeology. Consists of ploughsoil overlying a deep sequence of alluvial layers.						Length (m)	30
						Width (m)	6
						Avg. depth (m)	2
Context No.	Type	Fill Of	Width (m)	Depth (m)	Description	Finds	Date
2600	Layer		6	0.25	Ploughsoil. Dark greyish brown clayey silt, firm.		

2601	Layer		6	0.35	Alluvial Layer. Light grey silty clay with orangish and yellowish mottling, firm. Overlies alluvial layer (2602).		
2602	Layer		6	0.45	Alluvial Layer. Mid brownish grey with yellowish mottling silty clay, firm, stoneless. Overlies alluvial layer (2603).		
2603	Layer			0.45	Alluvial Layer. Mid grey silty clay with common mottling, soft. Overlies alluvial layer (2604).		
2604	Layer		6	0.5	Alluvial Layer. Mid bluish grey silty clay with organic material, soft and stoneless.		
2605	Void						
2606	Void						
2607	Void						
2608	Void						

### Trench 27

General description						Orientation	N-S
Trench devoid of archaeology. Consists of ploughsoil overlying a deep sequence of alluvial deposits. Test pit to 3m excavated to north-east end of trench						Length (m)	30
						Width (m)	6
						Avg. depth (m)	3
Context No.	Type	Fill Of	Width (m)	Depth (m)	Description	Finds	Date
2700	Layer			0.38	Ploughsoil. Dark greyish brown clayey silt, firm.		
2701	Layer			0.44	Alluvial Layer. Light grey silty clay with yellowish and orangish mottling, firm. Overlies alluvial layer (2702).		
2702	Layer			0.33	Alluvial Layer. Mid brownish grey silty clay with occasional reddish mottling, firm. Overlies alluvial layer (2703).		
2703	Layer			0.35	Alluvial Layer. Light grey silty clay with frequent yellowish mottling, soft and stoneless. Overlies alluvial layer (2704).		
2704	Layer			0.4	Alluvial Layer. Mid bluish grey silty clay with organic material, soft and stoneless. Overlies alluvial layer (2705).		
2705	Layer			0.5	Alluvial Layer. Mid/dark blue grey sandy clay with organic material.		

### Trench 28

General description						Orientation	NE - SW
Trench devoid of archaeology. Consists of ploughsoil overlying deep sequence of alluvial deposits and organic buried soil between these.						Length (m)	30
						Width (m)	6
						Avg. depth (m)	2

Context No.	Type	Fill Of	Width (m)	Depth (m)	Description	Finds	Date
2800	Layer		6	0.3	Ploughsoil. Dark greyish brown clayey silt, firm.		
2801	Layer			0.47	Alluvial Layer. Light grey silty clay with common pale yellowish mottling, firm. Overlies alluvial layer (2802).		
2802	Layer			0.25	Alluvial Layer. Mid brownish grey silty clay with reddish mottling, firm and stoneless. Overlies buried soil (2803).		
2803	Layer			0.12	Buried soil. Black humic clayey silt, soft. Overlies alluvial layer (2804).		
2804	Layer			0.65	Alluvial Layer. Mid grey silty clay with common mottling, soft and stoneless. Overlies alluvial layer (2805).		
2805	Layer			0.35	Alluvial Layer. Mid bluish grey silty clay with organic material, soft and stoneless.		
<b>Trench 29</b>							
General description					Orientation	NE-SW	
Trench devoid of archaeology. Consists of ploughsoil overlying a deep sequence of alluvial layers and organic buried soil between these.					Length (m)	30	
					Width (m)	6	
					Avg. depth (m)	2	
Context No.	Type	Fill Of	Width (m)	Depth (m)	Description	Finds	Date
2900	Layer			0.3	Ploughsoil. Dark greyish brown compact clayey silt.		
2901	Layer			0.35	Alluvial Layer. Light grey silty clay with common pale yellowish mottling, firm. Overlies alluvial layer (2902).		
2902	Layer			0.24	Alluvial Layer. Mid brownish grey silty clay with reddish mottling, firm and stoneless. Overlies buried soil (2903).		
2903	Layer			0.12	Buried soil. Black humic clayey silt, soft. Overlies alluvial layer (2904).		
2904	Layer			0.25	Alluvial Layer. Light bluish grey silty clay with yellow mottling, soft. Overlies alluvial layer (2905).		
2905	Layer			0.4	Alluvial Layer. Mid grey silty clay with common mottling, soft and stoneless. Overlies alluvial layer (2906).		
2906	Layer				Alluvial Layer. Mid bluish grey silty clay with organic material, soft and stoneless.		
<b>Trench 30</b>							

General description						Orientation	NW - SE
Trench devoid of archaeology. Consists of ploughsoil overlying deep sequence of alluvial deposits and organic buried soil between these.						Length (m)	30
						Width (m)	6
						Avg. depth (m)	2
Context No.	Type	Fill Of	Width (m)	Depth (m)	Description	Finds	Date
3000	Layer			0.3	Ploughsoil. Dark greyish brown clayey silt, firm.		
3001	Layer			0.45	Alluvial Layer. Light grey silty clay with frequent orangish and yellowish mottling, firm, no inclusion visible. Overlies alluvial layer (3002).		
3002	Layer			0.43	Alluvial Layer. Mid brownish grey silty clay with occasional mottling, firm. Overlies alluvial layer (3003).		
3003	Layer			0.39	Alluvial Layer. Mid grey with frequent reddish mottling, soft and stoneless. Overlies alluvial layer (3004).		
3004	Layer			0.42	Alluvial Layer. Mid bluish grey silty clay with organic material, soft and stoneless.		

### Trench 31

General description						Orientation	N - S
Trench devoid of archaeology. Consists of ploughsoil overlying deep sequence of alluvial layers and organic buried soil between these.						Length (m)	30
						Width (m)	6
						Avg. depth (m)	2
Context No.	Type	Fill Of	Width (m)	Depth (m)	Description	Finds	Date
3100	Layer		6	0.25	Ploughsoil. Dark greyish brown clayey silt, firm.		
3101	Layer			0.45	Alluvial Layer. Light grey silty clay with common pale yellowish mottling, firm. Overlies alluvial layer (3102).		
3102	Layer			0.3	Alluvial Layer. Mid brownish grey silty clay with reddish mottling, firm and stoneless. Overlies buried soil (3103).		
3103	Layer			0.1	Buried soil. Black humic clayey silt, soft. Overlies alluvial layer (3104).		
3104	Layer			0.4	Alluvial Layer. Mid grey silty clay with common mottling, soft and stoneless. Overlies alluvial layer (3105).		
3105	Layer			0.5	Alluvial Layer. Mid bluish grey silty clay with organic material, soft and stoneless.		

### Trench 32

General description						Orientation	NW-SE
---------------------	--	--	--	--	--	-------------	-------



Trench devoid of archaeology. Consists of ploughsoil overlying deep sequence of alluvial layers and organic buried soil between these.						Length (m)	30
						Width (m)	6
						Avg. depth (m)	2
Context No.	Type	Fill Of	Width (m)	Depth (m)	Description	Finds	Date
3200	Layer			0.25	Ploughsoil. Dark greyish brown clayey silt, firm.		
3201	Layer			0.32	Alluvial Layer. Light grey silty clay with common pale yellowish mottling, firm. Overlies alluvial layer (3202).		
3202	Layer			0.25	Alluvial Layer. Mid brownish grey silty clay with reddish mottling, firm and stoneless. Overlies buried soil (3203).		
3203	Layer			0.1	Buried soil. Black humic clayey silt, soft. Overlies alluvial layer (3204).		
3204	Layer			0.6	Alluvial Layer. Mid grey silty clay with common mottling, soft and stoneless. Overlies alluvial layer (3205).		
3205	Layer			0.4	Alluvial Layer. Mid bluish grey silty clay with organic material, soft and stoneless.		

### Trench 33

General description						Orientation	NE-SW
Trench devoid of archaeology. Consists of ploughsoil overlying deep sequence of alluvial deposits and organic buried soil between these.						Length (m)	30
						Width (m)	6
						Avg. depth (m)	2
Context No.	Type	Fill Of	Width (m)	Depth (m)	Description	Finds	Date
3300	Layer			0.25	Ploughsoil. Dark greyish brown clayey silt, firm with occasional rounded small pebbles.		
3301	Layer			0.42	Alluvial Layer. Light grey silty clay with frequent yellowish and orangish mottling, firm. Overlies alluvial layer (3302).		
3302	Layer			0.2	Alluvial Layer. Mid brownish grey silty clay with occasional pale yellowish mottling, firm. Overlies buried soil (3303).		
3303	Layer			0.12	Buried soil. Black humic clayey silt, soft. Overlies alluvial layer (3304).		
3304	Layer			0.53	Alluvial Layer. Light bluish grey silty clay with yellowish mottling, soft. Overlies alluvial layer (3305).		
3305	Layer			0.45	Alluvial Layer. Mid bluish grey silty clay with organic material, soft and stoneless.		

### Trench 34

General description						Orientation	NE-SW
Trench devoid of archaeology. Consists of ploughsoil overlying a deep sequence of alluvial layers and organic buried soil between these. Test pit to 3m excavated to north-east end of trench.						Length (m)	30
						Width (m)	6
						Avg. depth (m)	3
Context No.	Type	Fill Of	Width (m)	Depth (m)	Description	Finds	Date
3400	Layer			0.3	Ploughsoil. Dark greyish brown clayey silt, firm.		
3401	Layer			0.45	Alluvial Layer. Light grey silty clay with common pale yellowish mottling, firm. Overlies alluvial layer (3402).		
3402	Layer			0.25	Alluvial Layer. Mid brownish grey silty clay with reddish mottling, firm and stoneless. Overlies alluvial layer (3403).		
3403	Layer			0.65	Alluvial Layer. Mid grey silty clay with common mottling, soft and stoneless. Overlies alluvial layer (3404).		
3404	Layer			1	Alluvial Layer. Mid bluish grey silty clay with organic material with mid grey brown laminations. Soft and stoneless. Overlies alluvial layer (3405).		
3405	Layer				Alluvial Layer. Mid/dark blue grey sand clay laminated, planar.		
<b>Trench 35</b>							
General description						Orientation	NE-SW
Trench revealed single ditch. Consists of ploughsoil overlying a deep sequence of alluvial layers. Excavated to a max depth of approx 1.5m.						Length (m)	30
						Width (m)	6
						Avg. depth (m)	0.3
Context No.	Type	Fill Of	Width (m)	Depth (m)	Description	Finds	Date
3500	Layer			0.3	Ploughsoil. Dark greyish brown clayey silt		
3501	Layer				Alluvial Layer. Light brown silty clay with common pale yellowish mottling, firm		
3502	Layer			0.35	Alluvial Layer. Mid brownish grey silty clay with reddish mottling, firm and stoneless		
3503	Layer			0.4	Alluvial Layer. Mid grey silty clay with common mottling, soft and stoneless		
3504	Void						
3505	Cut		2.94	0.32	Ditch		
3506	Fill	3505	2.94	0.32	Primary Fill. Mid brown grey with flecks of orange compact silty clay. Not fully excavated as 1m limit reached.		
<b>Trench 36</b>							

General description						Orientation	NE-SW
Trench devoid of archaeology. Consists of ploughsoil overlying a sequence of alluvial deposits.						Length (m)	30
						Width (m)	6
						Avg. depth (m)	2
Context No.	Type	Fill Of	Width (m)	Depth (m)	Description	Finds	Date
3600	Layer			0.3	Ploughsoil. Dark greyish brown clayey silt, firm with occasional rounded small pebbles.		
3601	Layer			0.3	Alluvial Layer. Light grey silty clay with frequent orangish mottling, firm and stoneless. Overlies alluvial layer (3602).		
3602	Layer			0.32	Alluvial Layer. Mid brownish grey silty clay with common reddish mottling, firm and stoneless. Overlies alluvial layer (3603).		
3603	Layer			0.65	Alluvial Layer. Mid grey silty clay with moderate reddish mottling. Overlies alluvial layer (3604).		
3604	Layer			0.4	Alluvial Layer. Mid bluish grey silty clay with organic material, soft and stoneless.		
<b>Trench 37</b>							
General description						Orientation	NW-SE
Trench revealed a single large deep ditch cutting alluvial layers possibly post-medieval in date. Trench consists of ploughsoil overlying buried soil and a sequence of alluvial deposits.						Length (m)	30
						Width (m)	6
						Avg. depth (m)	2
Context No.	Type	Fill Of	Width (m)	Depth (m)	Description	Finds	Date
3700	Layer			0.3	Ploughsoil. Dark greyish brown clayey silt, firm.		
3701	Layer			0.4	Alluvial Layer. Mid grey silty clay with frequent orangish mottling, firm and stoneless.		
3702	Layer			0.23	Alluvial Layer. Mid brownish grey silty clay with occasional yellowish mottling, firm.		
3703	Layer			0.08	Buried soil. Black humic clayey silt, soft.		
3704	Layer			0.45	Alluvial Layer. Mid grey silty clay with reddish mottling, soft and stoneless.		
3705	Layer				Alluvial Layer. Mid bluish grey silty clay with organic material, soft.		
3706	Cut		3.64	0.6	Ditch		
3707	Fill	3706	3.64	0.6	Secondary Fill. Firm dark blueish grey silty clay		
<b>Trench 38</b>							
General description						Orientation	E-W

Trench devoid of archaeology, consisting in a ploughsoil and subsoil overlying a deep sequence of alluvial layer and organic buried soil between these.						Length (m)	30
						Width (m)	6
						Avg. depth (m)	2
Context No.	Type	Fill Of	Width (m)	Depth (m)	Description	Finds	Date
3800	Layer			0.3	Ploughsoil. Dark greyish brown clayey silt, firm with occasional rounded pebbles and sub-angular flint fragments.		
3801	Layer			0.55	Alluvial Layer. Light grey silty clay with frequent yellowish and orangish mottling, firm. Stoneless.		
3802	Layer			0.15	Buried soil. Dark humic grey clayey silt with occasional reddish mottling, firm. Stoneless.		
3803	Layer			0.76	Alluvial Layer. Grey silty clay. Oxidised. Firm and stoneless.		
3804	Layer				Alluvial Layer. Blueish grey clayey silt. Stoneless and firm. Occasional black organic detritus.		
<b>Trench 39</b>							
General description						Orientation	NE-SW
Trench devoid of archaeology. Consists of ploughsoil overlying a sequence of alluvial deposits and buried soil layer between these.						Length (m)	30
						Width (m)	6
						Avg. depth (m)	2
Context No.	Type	Fill Of	Width (m)	Depth (m)	Description	Finds	Date
3900	Layer			0.3	Ploughsoil. Dark greyish brown clayey silt, firm.		
3901	Layer			0.4	Alluvial Layer. Mid grey silty clay with yellowish and orangish mottling, firm and stoneless.		
3902	Layer			0.2	Alluvial Layer. Mid grey silty clay with common mottling, firm and stoneless. Wavy lamination throughout.		
3903	Layer			0.13	Buried soil. Very dark brown humic clayey silt, soft.		
3904	Layer			0.67	Alluvial Layer. Light grey silty clay with common mottling, firm and stoneless.		
3905	Layer			0.3	Alluvial Layer. Mid bluish grey silty clay with organic material, soft and stoneless.		
<b>Trench 40</b>							
General description						Orientation	E-W
Trench devoid of archaeology. Consists of ploughsoil overlying a sequence of alluvial deposits.						Length (m)	30
						Width (m)	6
						Avg. depth (m)	2

Context No.	Type	Fill Of	Width (m)	Depth (m)	Description	Finds	Date
4000	Layer			0.34	Ploughsoil. Dark greyish brown clayey silt, firm.		
4001	Layer			0.53	Alluvial Layer. Light grey silty clay with frequent orangish and reddish mottling, firm, stoneless. Overlies alluvial layer (4002).		
4002	Layer			0.24	Alluvial Layer. Mid brownish grey silty clay with reddish mottling. Overlies alluvial layer (4003).		
4003	Layer			0.62	Alluvial Layer. Mid grey silty clay with reddish mottling. Overlies alluvial layer (4004).		
4004	Layer			0.43	Alluvial Layer. Mid bluish grey silty clay with organic material, soft and stoneless.		
<b>Trench 41</b>							
General description					Orientation	N-S	
Trench devoid of archaeology. Consists of ploughsoil overlying a sequence of alluvial deposits and buried soil between these.					Length (m)	30	
					Width (m)	6	
					Avg. depth (m)	2	
Context No.	Type	Fill Of	Width (m)	Depth (m)	Description	Finds	Date
4100	Layer			0.25	Ploughsoil. Dark greyish brown clayey silt, firm.		
4101	Layer			0.35	Alluvial Layer. Mid grey firm silty clay with reddish mottling.		
4102	Layer			0.3	Alluvial Layer. Mid grey silty clay. Oxidised. Stoneless and firm.		
4103	Layer			0.1	Buried soil. Dark greyish brown humic clayey silt, soft. Present only in northern part of the trench.		
4104	Layer			0.8	Alluvial Layer. Mid grey firm silty clay with reddish mottling.		
4105	Layer			0.35	Alluvial Layer. Mid bluish grey silty clay with organic material, soft and stoneless.		
4106	Void						
<b>Trench 43</b>							
General description					Orientation	N-S	
Trench devoid of archaeology. Consists of ploughsoil overlying a sequence of alluvial deposits and buried soil layer between these.					Length (m)	30	
					Width (m)	6	
					Avg. depth (m)	2	
Context No.	Type	Fill Of	Width (m)	Depth (m)	Description	Finds	Date
4300	Layer			0.3	Ploughsoil. Dark greyish brown clayey silt, firm with occasional rounded fine pebbles.		

4301	Layer			0.47	Alluvial Layer. Light grey with frequent yellowish and orangish mottling, firm and stoneless. Overlies alluvial layer (4302).		
4302	Layer			0.19	Alluvial Layer. Mid brownish grey silty clay with occasional reddish mottling, firm. Overlies buried soil (4303).		
4303	Layer			0.07	Buried soil. Black humic clayey silt, loose. Present only in northern part of the trench. Overlies alluvial layer (4304).		
4304	Layer			0.6	Alluvial Layer. Mid grey silty clay with common yellowish and reddish mottling, soft and stoneless. Overlies alluvial layer (4305).		
4305	Layer			0.4	Alluvial Layer. Mid bluish grey silty clay with organic material, soft and stoneless.		

#### Trench 44

General description						Orientation	NE-SW
Trench devoid of archaeology. Consists of ploughsoil overlying a deep sequence of alluvial layer and a thin organic buried soil appearing in eastern part of the trench.						Length (m)	30
						Width (m)	6
						Avg. depth (m)	2

Context No.	Type	Fill Of	Width (m)	Depth (m)	Description	Finds	Date
4400	Layer			0.34	Ploughsoil. Dark greyish brown compact clayey silt.		
4401	Layer			0.44	Alluvial Layer. Light grey silty clay with common pale yellowish mottling, firm. Overlies alluvial layer (4402).		
4402	Layer			0.37	Alluvial Layer. Mid brownish grey silty clay with reddish mottling, firm and stoneless. Overlies alluvial layer (4403).		
4403	Layer			0.53	Alluvial Layer. Mid grey silty clay with common mottling, soft and stoneless. Overlies alluvial layer (4404).		
4404	Layer				Alluvial Layer. Mid bluish grey silty clay with organic material, soft and stoneless.		

#### Trench 45

General description						Orientation	N-S
Trench revealed a single boundary ditch. Consists of ploughsoil overlying a sequence of alluvial layers.						Length (m)	30
						Width (m)	6
						Avg. depth (m)	0.3

Context No.	Type	Fill Of	Width (m)	Depth (m)	Description	Finds	Date
4500	Layer			0.3	Ploughsoil. Dark brownish grey compact silty clay		

4501	Cut		3.7	0.74	Ditch		
4502	Fill	4501	1.5	0.24	Primary Fill. Dark brownish grey clayey silt, firm with organic material.	Bone	
4503	Fill	4501	3.7	0.7	Secondary Fill. Dark brownish grey clayey silt with frequent pale yellowish mottling.		
4504	Layer			0.5	Alluvial Layer. Mid grey with frequent pale yellowish and orangish mottling, firm, no inclusion visible.		
4505	Layer			0.25	Alluvial Layer. Mid brownish grey silty clay with common mottling, firm.		
4506	Layer			0.5	Alluvial Layer. Mid grey silty clay with reddish mottling, soft.		
4507	Layer				Alluvial Layer. Mid bluish grey silty clay with organic material, soft.		
4508	Void						
<b>Trench 46</b>							
General description						Orientation	N-S
Trench devoid of archaeology. Consisted of ploughsoil and a thin interface overlying alluvial deposits. A possible buried soil recorded at c 1m bpgl. Oxidised and waterlogged alluvium recorded at the base.						Length (m)	30
						Width (m)	6
						Avg. depth (m)	2
Context No.	Type	Fill Of	Width (m)	Depth (m)	Description	Finds	Date
4600	Layer			0.36	Ploughsoil. Dark greyish brown clayey silt, firm.		
4601	Layer			0.45	Alluvial Layer. Mid yellow brown firm silty clay, overlies buried soil (4602).		
4602	Layer			0.12	Buried soil. Dark grey silty clay. Humic and firm. Overlies alluvial layer (4603).		
4603	Layer			0.5	Alluvial Layer. Pale brown silty clay. Oxidised. Firm. Overlies alluvial layer (4604).		
4604	Layer			0.7	Alluvial Layer. Mid blue grey plastic silty clay		
<b>Trench 47</b>							
General description						Orientation	N-S
Trench devoid of archaeology. Consists of ploughsoil covering layers of oxidised alluvium and a possible buried soil. Oxidised laminated and waterlogged alluvium with plant material recorded at the base.						Length (m)	30
						Width (m)	6
						Avg. depth (m)	2
Context No.	Type	Fill Of	Width (m)	Depth (m)	Description	Finds	Date
4700	Layer			0.3	Ploughsoil. Dark greyish brown clayey silt. Firm.		
4701	Layer			0.35	Alluvial Layer. Mid reddish yellow silty clay. Oxidised with grey depletion patches. Firm. Overlies buried soil (4702).		

4702	Layer			0.2	Buried soil. Dark grey silty clay. Humic. Firm. Overlies alluvial layer (4703).		
4703	Layer			0.5	Alluvial Layer. Pale brown silty clay. Oxidised. Laminated. Soft. Overlies alluvial layer (4704).		
4704	Layer			0.8	Alluvial Layer. Mid blueish grey clay silt. Occasional plant fragments. Soft.		

#### Trench 48

General description						Orientation	E - W
Trench devoid of archaeology. Consists of ploughsoil overlying alluvium						Length (m)	30
						Width (m)	6
						Avg. depth (m)	2

Context No.	Type	Fill Of	Width (m)	Depth (m)	Description	Finds	Date
4800	Layer			0.3	Ploughsoil. Dark greyish brown clayey silt, firm.		
4801	Layer			0.35	Alluvial Layer. Light grey silty clay with common pale yellowish mottling, firm.		
4802	Layer			0.4	Alluvial Layer. Mid brownish grey silty clay with common reddish mottling, firm.		
4803	Layer			0.48	Alluvial Layer. Mid grey silty clay with common mottling, soft.		
4804	Layer			0.45	Alluvial Layer. Mid bluish grey silty clay with organic material, soft.		

#### Trench 49

General description						Orientation	N - S
Trench devoid of archaeology. Consists of ploughsoil overlying a sequence of alluvial layers.						Length (m)	30
						Width (m)	6
						Avg. depth (m)	2

Context No.	Type	Fill Of	Width (m)	Depth (m)	Description	Finds	Date
4900	Layer		6	0.25	Ploughsoil. Dark greyish brown clayey silt, firm.		
4901	Layer			0.2	Alluvial Layer. Pale yellowish red with grey patches. Silty clay. Firm and stoneless. Overlies alluvial layer (4902).		
4902	Layer			0.3	Alluvial Layer. Mid grey silty clay with common mottling. Firm and stoneless. Overlies alluvial layer (4903).		
4903	Layer			0.6	Alluvial Layer. Pale brown silty clay. Firm and stoneless. Overlies alluvial layer (4904).		
4904	Layer			0.8	Alluvial Layer. Mid blueish grey clay silt with common plant fragments. Soft.		



Trench 50							
General description						Orientation	N-S
Trench devoid of archaeology. Consists of ploughsoil overlying a sequence of alluvial layers with an organic buried soil layer between these.						Length (m)	30
						Width (m)	6
						Avg. depth (m)	2
Context No.	Type	Fill Of	Width (m)	Depth (m)	Description	Finds	Date
5000	Layer			0.3	Ploughsoil. Dark greyish brown clayey silt, firm.		
5001	Layer			0.21	Alluvial Layer. Mid grey silty clay. Common mottling. Firm and stoneless. Overlies alluvial layer (5002).		
5002	Layer			0.29	Alluvial Layer. Mid grey silty clay with occasional mottling. Firm and stoneless. Overlies buried soil (5003).		
5003	Layer			0.18	Buried soil. Dark grey silty clay. Humic. Firm and stoneless. Overlies alluvial layer (5004).		
5004	Layer			0.32	Alluvial Layer. Mid brown silty clay. Oxidised. Firm and stoneless. Overlies alluvial layer (5005).		
5005	Layer			0.3	Alluvial Layer. Pale brown silty clay with common mottling. Laminated. Firm and stoneless. Overlies alluvial layer (5006).		
5006	Layer				Alluvial Layer. Mid blueish grey clay silt with occasional plant fragments. laminated. Stoneless and soft.		
Trench 51							
General description						Orientation	E-W
Trench devoid of archaeology. Consists of ploughsoil overlaying a sequence of alluvial layers with buried soil between these.						Length (m)	30
						Width (m)	6
						Avg. depth (m)	2
Context No.	Type	Fill Of	Width (m)	Depth (m)	Description	Finds	Date
5100	Layer			0.19	Ploughsoil. Dark greyish brown clayey silt, firm.		
5101	Layer			0.36	Alluvial Layer. Light grey silty clay with common pale reddish mottling, firm. Overlies alluvial layer (5102).		
5102	Layer			0.2	Alluvial Layer. Mid brownish grey silty clay with reddish mottling, firm and stoneless. Overlies alluvial layer (5103).		
5103	Layer			0.1	Alluvial Layer. Light grey silty clay, firm. Overlies buried soil (5104).		
5104	Layer			0.1	Buried soil. Black humic clayey silt, soft. Overlies alluvial layer (5105).		

5105	Layer			0.12	Alluvial Layer. Light grey silty clay. Overlies alluvial layer (5106).		
5106	Layer			0.7	Alluvial Layer. Mid brown silty clay with common grey mottling, soft and stoneless. Overlies alluvial layer (5107).		
5107	Layer			0.3	Alluvial Layer. Mid bluish grey silty clay with organic material, soft and stoneless.		

### Trench 52

General description						Orientation	N-S
Trench devoid of archaeology. Consists of ploughsoil overlying a sequence of alluvial deposits.						Length (m)	30
						Width (m)	6
						Avg. depth (m)	2
Context No.	Type	Fill Of	Width (m)	Depth (m)	Description	Finds	Date
5200	Layer			0.23	Ploughsoil. Dark greyish brown clayey silt, firm.		
5201	Layer			0.15	Alluvial Layer. Light grey silty clay with pale brownish mottling. Overlies alluvial layer (5202).		
5202	Layer			0.4	Alluvial Layer. Mid brownish grey silty clay with reddish mottling, firm and stoneless. Overlies alluvial layer (5203).		
5203	Layer			0.14	Alluvial Layer. Dark bluish grey, silty clay with dark brown mottling. Overlies alluvial layer (5204).		
5204	Layer			0.52	Alluvial Layer. Mid grey silty clay with common mottling, soft and stoneless. Overlies alluvial layer (5205).		
5205	Layer			0.56	Alluvial Layer. Mid bluish grey silty clay with organic material, soft and stoneless.		

### Trench 53

General description						Orientation	E - W
Trench devoid of archaeology. Consists of ploughsoil overlying a deep sequence of alluvial layers.						Length (m)	30
						Width (m)	6
						Avg. depth (m)	2
Context No.	Type	Fill Of	Width (m)	Depth (m)	Description	Finds	Date
5300	Layer		6	0.25	Ploughsoil. Dark greyish brown clayey silt, firm.		
5301	Layer			0.47	Alluvial Layer. Mid grey silty clay with bleached upper part. Mottled. Firm and stoneless. Overlies buried soil (5302).		
5302	Layer			0.14	Buried soil. Very dark grey silty clay. Humic. Firm. Overlies alluvial layer (5303).		

5303	Layer			0.2	Alluvial Layer. Strong brown silty clay. Firm and stoneless. Overlies alluvial layer (5304).		
5304	Layer			0.5	Alluvial Layer. Mid brown oxidised silty clay. Soft. Laminated. Overlies alluvial layer (5305).		
5305	Layer			0.7	Alluvial Layer. Mid bluish grey clay silt with common plant fragments. Soft.		

#### Trench 54

General description						Orientation	E-W
Trench devoid of archaeology. Consists of ploughsoil overlying a sequence of alluvium with an organic buried soil layer between these.						Length (m)	30
						Width (m)	6
						Avg. depth (m)	2
Context No.	Type	Fill Of	Width (m)	Depth (m)	Description	Finds	Date
5400	Layer			0.3	Ploughsoil. Dark greyish brown clayey silt, firm.		
5401	Layer			0.53	Alluvial Layer. Mid grey silty clay. Common pale yellow mottling. Firm and stoneless. Overlies buried soil (5402).		
5402	Layer			0.2	Buried soil. Dark grey silty clay. Humic. firm and stoneless. Overlies alluvial layer (5403).		
5403	Layer			0.34	Alluvial Layer. Pale brown silty clay. Oxidised. Firm and stoneless. Overlies alluvial layer (5404).		
5404	Layer			0.2	Alluvial Layer. Mid grey silty clay with common mottling. Laminated. Stoneless and firm. Overlies alluvial layer (5405).		
5405	Layer				Alluvial Layer. Mid blueish grey clayey silt with plant material. Soft.		

#### Trench 55

General description						Orientation	N-S
Trench devoid of archaeology. Consists of ploughsoil overlying a sequence alluvial layers with an organic buried soil deposit between these.						Length (m)	30
						Width (m)	6
						Avg. depth (m)	2
Context No.	Type	Fill Of	Width (m)	Depth (m)	Description	Finds	Date
5500	Layer			0.23	Ploughsoil. Dark greyish brown clayey silt.		
5501	Layer			0.12	Alluvial Layer. Light grey silt clay. Overlies alluvial layer (5502).		
5502	Layer			0.51	Alluvial Layer. Mid brown oxidised silt clay. Overlies buried soil (5503).		

5503	Layer			0.14	Buried soil. Dark brown grey with orange flecks of oxidised material. Overlies alluvial layer (5504).		
5504	Layer			0.82	Alluvial Layer. Mid brown silt clay with orange flecks of oxidised material. Overlies alluvial layer (5505).		
5505	Layer				Alluvial Layer. Light blue grey clay with some dark organic inclusions.		

### Trench 56

General description		Orientation	E-W
Trench devoid of archaeology. Consists of ploughsoil covering sequence of alluvial layers and a buried soil.		Length (m)	30
		Width (m)	6
		Avg. depth (m)	2

Context No.	Type	Fill Of	Width (m)	Depth (m)	Description	Finds	Date
5600	Layer		6	0.23	Ploughsoil. Dark brownish grey clayey silt.		
5601	Layer		6	0.24	Alluvial Layer. Light grey silty clay with common pale yellowish mottling, firm. Overlies alluvial layer (5602).		
5602	Layer		6	0.15	Alluvial Layer. Mid brownish grey silty clay with reddish mottling, firm and stoneless. Overlies alluvial layer (5603).		
5603	Layer		6	0.1	Alluvial Layer. Light grey silty clay with common pale yellowish mottling, firm. Overlies buried soil (5604).		
5604	Layer		6	0.2	Buried soil. Black humic clayey silt, soft. Overlies alluvial layer (5605).		
5605	Layer		6	0.1	Alluvial Layer. Light grey silty clay with common pale yellowish mottling, firm. Overlies alluvial layer (5606).		
5606	Layer		6	0.75	Alluvial Layer. Mid brown silty clay with common mottling, soft and stoneless. Overlies alluvial layer (5607).		
5607	Layer		6	0.2	Alluvial Layer. Mid bluish grey silty clay with organic material, soft and stoneless.		

### Trench 57

General description		Orientation	N - S
Trench revealed single post-medieval ditch. Consists of ploughsoil overlying a sequence of alluvium with an organic buried soil layer between these.		Length (m)	30
		Width (m)	6
		Avg. depth (m)	0.25

Context No.	Type	Fill Of	Width (m)	Depth (m)	Description	Finds	Date
-------------	------	---------	-----------	-----------	-------------	-------	------

5700	Layer		6	0.25	Ploughsoil. Dark greyish brown clayey silt, no inclusion visible.		
5701	Layer			0.35	Alluvial Layer. Mid grey silty clay. Oxidised, common mottling. Stoneless and firm.		
5702	Layer			0.2	Buried soil. Very dark grey silty clay. Humic and firm.		
5703	Layer			1.1	Alluvial Layer. Mid brown silty clay. Oxidised. Laminated. Soft.		
5704	Layer			0.3	Alluvial Layer. Mid blueish grey silty clay with plant fragments. Soft.		
5705	Cut		2.9	0.6	Ditch. Machine dug, recorded in section		
5706	Fill	5705	2.9	0.6	Secondary Fill. Mid greyish brown loamy clay with patches of yellowish grey clay. Moderate to soft compaction with occasional rounded stones. 2 animal bones retrieved	Bone	

### Trench 58

General description		Orientation	N-S
Trench devoid of archaeology. Consists of ploughsoil overlying a sequence of alluvial layers with an organic buried soil layer between these.		Length (m)	30
		Width (m)	6
		Avg. depth (m)	2

Context No.	Type	Fill Of	Width (m)	Depth (m)	Description	Finds	Date
5800	Layer			0.28	Ploughsoil. Firm dark greyish brown clayey silt. Overlies alluvial layer (5801).		
5801	Layer			0.27	Alluvial Layer. Stiff dark brownish red and mid greyish brown silty clay. Overlies alluvial layer (5802).		
5802	Layer			0.27	Alluvial Layer. Stiff mid greyish blue and dark bluish grey silty clay. Overlies alluvial layer (5803).		
5803	Layer			0.09	Alluvial Layer. Firm dark bluish green and dark greyish blue clayey silt. Overlies layer (5804).		
5804	Layer			0.09	Other Layer. Soft dark greyish brown peaty silt. Overlies alluvial layer (5805).		
5805	Layer			0.25	Alluvial Layer. Overlies alluvial layer (5806).		
5806	Layer			0.4	Alluvial Layer. Firm to slightly soft dark bluish grey clayey silt. Overlies alluvial layer (5807).		
5807	Layer				Alluvial Layer. Very soft mid to dark greyish blue clayey silt.		
5808	Void						

### Trench 59

General description		Orientation	E-W
---------------------	--	-------------	-----

Trench devoid of archaeology. Consists of ploughsoil overlying a sequence of alluvial deposits.						Length (m)	30
						Width (m)	6
						Avg. depth (m)	2
Context No.	Type	Fill Of	Width (m)	Depth (m)	Description	Finds	Date
5900	Layer			0.21	Ploughsoil. Dark greyish brown clayey silt, firm, stoneless.		
5901	Layer			0.41	Alluvial Layer. Light brown silty clay with common pale yellowish mottling, firm. Overlies alluvial layer (5902).		
5902	Layer			0.2	Alluvial Layer. Mid brownish grey silty clay with reddish mottling, firm and stoneless. Overlies alluvial layer (5903).		
5903	Layer			0.19	Alluvial Layer. Dark bluish grey silty clay with dark brown mottling. Overlies alluvial layer (5904).		
5904	Layer			0.49	Alluvial Layer. Mid grey silty clay with common mottling, soft and stoneless. Overlies alluvial layer (5905).		
5905	Layer			0.5	Alluvial Layer. Mid bluish grey silty clay with organic material, soft and stoneless.		

#### Trench 60

General description						Orientation	N-S
Trench devoid of archaeology. Consists of ploughsoil overlying a sequence of alluvial deposits with an organic buried soil layer between these (only in southern end).						Length (m)	30
						Width (m)	6
						Avg. depth (m)	2
Context No.	Type	Fill Of	Width (m)	Depth (m)	Description	Finds	Date
6000	Layer		6	0.2	Ploughsoil. Dark brownish grey, compact silty clay.		
6001	Layer		6	0.44	Alluvial Layer. Light grey silty clay with common pale yellowish mottling. Firm and stoneless.		
6002	Layer		6	0.3	Alluvial Layer. Mid grey silty clay. Firm. Laminated.		
6003	Layer		6	0.45	Alluvial Layer. Mid brown silty clay with grey mottling		
6004	Layer		6	0.4	Alluvial Layer. Mid bluish grey silty clay with organic material, soft and stoneless. Lenses of dark blackish blue at northern side.		

#### Trench 61

General description						Orientation	E - W
Trench devoid of archaeology. Consists of ploughsoil covering a deep sequence of alluvial layers and a possible stabilisation horizon at c 0.70m bpgl.						Length (m)	30
						Width (m)	6
						Avg. depth (m)	2

Context No.	Type	Fill Of	Width (m)	Depth (m)	Description	Finds	Date
6100	Layer		6	0.35	Ploughsoil. Dark brownish grey clayey silt		
6101	Layer		6	0.25	Alluvial Layer. Light grey silty clay with common mottling. Stoneless and firm. Overlies alluvial layer (6102).		
6102	Layer			0.15	Alluvial Layer. Mid grey clay with reddish yellow mottling. Stoneless and firm. Overlies buried soil (6103).		
6103	Layer			0.1	Buried soil. Black humic clay silt. Firm. Overlies alluvial layer (6104).		
6104	Layer			0.7	Alluvial Layer. Mid grey silty clay with common mottling. Firm and stoneless. Overlies alluvial layer (6105).		
6105	Layer				Alluvial Layer. Grey clay silt with occasional organic matter. Soft.		

### Trench 62

#### General description

Trench revealed a single ditch. Consists of ploughsoil overlying a sequence of alluvial layers and a peaty soil at c 1m bpgl.

#### Orientation

N-S

#### Length (m)

30

#### Width (m)

6

#### Avg. depth (m)

0.45

Context No.	Type	Fill Of	Width (m)	Depth (m)	Description	Finds	Date
6200	Layer			0.3	Ploughsoil. Dark greyish brown compact clayey silt.		
6201	Layer			0.16	Alluvial Layer. Light grey silty clay with common pale yellowish mottling. Firm and stoneless.		
6202	Layer			0.39	Alluvial Layer. Mid grey silty clay. Firm. Laminated.		
6203	Layer			0.13	Buried soil. Black humic silt. Soft.		
6204	Layer			0.64	Alluvial Layer. Mid grey silty clay with common mottling. Soft and stoneless.		
6205	Layer				Alluvial Layer. Mid grey clay silt with rare organic matter. Soft and stoneless.		
6206	Cut		0.76	0.16	Ditch		
6207	Fill	6206	0.76	0.16	Secondary Fill. Light greyish blue silty clay with infrequent red/orange mottling, firm. Iron oxide inclusions.	CBM, Bone	Post-medieval

### Trench 63

#### General description

Trench devoid of archaeology. Consists of ploughsoil overlying a sequence of alluvial layers and a remnant of buried soil in between. Waterlogged alluvium with plant fragments recorded at bottom.

#### Orientation

NE-SW

#### Length (m)

30

#### Width (m)

6

#### Avg. depth (m)

2

Context No.	Type	Fill Of	Width (m)	Depth (m)	Description	Finds	Date
6300	Layer			0.25	Ploughsoil. Dark greyish brown clayey silt, firm, stoneless.		
6301	Layer			0.43	Alluvial Layer. Mid yellow brown clay silt with iron and manganese inclusions. Overlies alluvial layer (6302).		
6302	Layer			0.32	Alluvial Layer. Mid blue grey clay silt with iron and manganese inclusions. Overlies alluvial layer (6303).		
6303	Layer			0.3	Alluvial Layer. Mid grey brown clay silt with iron and manganese inclusions. Overlies buried soil (6304).		
6304	Layer			0.38	Buried soil. Mid brown grey clay silt - remains of buried soil. Overlies alluvial layer (6305).		
6305	Layer				Alluvial Layer. Mid blue grey silt clay with bands of organic material.		
<b>Trench 64</b>							
General description					Orientation	N-S	
Trench devoid of archaeology. Consists of ploughsoil overlying a sequence of alluvial deposits. Bedrock not reached at 2m depth.					Length (m)	30	
					Width (m)	6	
					Avg. depth (m)	2	
Context No.	Type	Fill Of	Width (m)	Depth (m)	Description	Finds	Date
6400	Layer			0.16	Ploughsoil. Dark brownish grey clayey silt.		
6401	Layer			0.26	Alluvial Layer. Light brown silty clay with common pale yellowish mottling, firm. Overlies alluvial layer (6402).		
6402	Layer			1.3	Alluvial Layer. Mid grey silty clay with common mottling, soft and stoneless. Overlies alluvial layer (6403).		
6403	Layer			0.46	Alluvial Layer. Mid bluish grey silty clay with organic material, soft and stoneless.		
<b>Trench 65</b>							
General description					Orientation	E-W	
Trench devoid of archaeology. Consists of ploughsoil overlying oxidised alluvium and buried peaty soil at c 0.80m bpgl.					Length (m)	30	
					Width (m)	6	
					Avg. depth (m)	2	
Context No.	Type	Fill Of	Width (m)	Depth (m)	Description	Finds	Date
6500	Layer			0.3	Ploughsoil. Dark greyish brown clayey silt. Firm.		



6501	Layer			0.3	Alluvial Layer. Mid grey silty clay with common mottling. Firm. Overlies alluvial layer (6502).		
6502	Layer			0.2	Alluvial Layer. Mid grey clay with common reddish yellow mottling. Rare lamination throughout. Firm. Overlies buried soil (6503).		
6503	Layer			0.15	Buried soil. Very dark grey silty clay. Firm. Overlies alluvial layer (6504).		
6504	Layer			0.7	Alluvial Layer. Mid grey silty clay with common mottling. Soft and stoneless. Overlies alluvial layer (6505).		
6505	Layer			0.3	Alluvial Layer. Mid blueish grey clay silt with rare organic matter. Soft.		

### Trench 66

#### General description

Trench revealed a single post-medieval ditch. Consists of ploughsoil overlying a sequence of alluvial layers and a possible organic buried soil appearing at the northern end of the trench.

#### Orientation

N-S

#### Length (m)

30

#### Width (m)

6

#### Avg. depth (m)

0.32

Context No.	Type	Fill Of	Width (m)	Depth (m)	Description	Finds	Date
6600	Layer			0.3	Ploughsoil. Dark greyish brown compact clayey silt.		
6601	Layer			0.46	Alluvial Layer. Mid grey silty clay with common reddish yellow mottling. Firm and stoneless.		
6602	Layer			0.2	Alluvial Layer. Mid grey silty clay. Laminated. Firm and stoneless.		
6603	Layer			0.1	Buried soil. Very dark grey humic silty clay. Firm.		
6604	Layer			0.5	Alluvial Layer. Mid brown silty clay (oxidised). Firm and stoneless.		
6605	Layer			0.3	Alluvial Layer. Light grey clayey silt. Soft. Rare plant fragments.		
6606	Void						
6607	Cut		0.48	0.27	Ditch. Disturbed by land drain		
6608	Fill	6607	0.48	0.27	Secondary Fill. Light greyish blue silty clay, firm with iron oxide inclusions.		
6609	Cut		0.2		Modern. Modern land drain cutting the ditch 6607.		

### Trench 67

#### General description

Trench devoid of archaeology. Ploughsoil covering oxidised alluvium and a possible buried soil. Waterlogged alluvium with plant fragments recorded at the base.

#### Orientation

W-E

#### Length (m)

30

#### Width (m)

6

#### Avg. depth (m)

2

Context No.	Type	Fill Of	Width (m)	Depth (m)	Description	Finds	Date
-------------	------	---------	-----------	-----------	-------------	-------	------

6700	Layer			0.25	Ploughsoil. Dark grey brown clayey silt. Firm.		
6701	Layer			0.21	Alluvial Layer. Mid yellowish red silty clay. Oxidised. Bioturbated. Firm. Overlies alluvial layer (6702).		
6702	Layer			0.15	Alluvial Layer. Mid grey silty clay with common mottling. Firm. Overlies alluvial layer (6703).		
6703	Layer			0.18	Alluvial Layer. Mid grey silty clay. Mottling present. Firm. Overlies buried soil (6704).		
6704	Layer			0.13	Buried soil. Very dark grey silty clay. Firm and stoneless. Overlies alluvial layer (6705).		
6705	Layer			0.74	Alluvial Layer. Pale brown, oxidised silty clay. Laminated. Soft and stoneless. Overlies alluvial layer (6706).		
6706	Layer				Alluvial Layer. Mid blueish grey clay silt with occasional organic matter. Soft.		
<b>Trench 68</b>							
General description						Orientation	N-S
Trench revealed a single boundary ditch. Trench revealed one ditch. Consists of ploughsoil overlying a sequence of alluvial layers.						Length (m)	30
						Width (m)	6
						Avg. depth (m)	0.22
Context No.	Type	Fill Of	Width (m)	Depth (m)	Description	Finds	Date
6800	Layer			0.22	Ploughsoil. Dark greyish brown clayey silt, firm.		
6801	Layer			0.46	Alluvial Layer. Mid grey mottled with mid reddish brown silty clay.		
6802	Layer			0.14	Alluvial Layer. Dark grey with mid reddish brown mottling from oxidation		
6803	Layer			0.42	Alluvial Layer. Light grey mottled with mid reddish brown silty clay		
6804	Layer			0.35	Alluvial Layer. Mid greyish brown mottled with light reddish brown silty clay. Lenses of very fine sand throughout.		
6805	Layer			0.12	Alluvial Layer. Mid grey, silty clay with some mid brown specks of sediment throughout context.		
6806	Cut		2.9	1.08	Ditch		
6807	Fill	6806	2.9	0.42	Secondary Fill. Mid greyish brown mottled with mid reddish brown specks. Silty clay		
6808	Fill	6806	1	0.32	Primary Fill. Pale reddish brown mottled with light grey silty clay		
6809	Fill	6806	2.32	0.38	Secondary Fill. Mid yellowish brown mottled by mid grey. Silty clay with fine sand lenses		

6810	Fill	6806	2.06	0.72	Secondary Fill. Mid grey silty clay		
<b>Trench 69</b>							
General description						Orientation	E-W
Trench revealed one ditch. Consists of ploughsoil and subsoil overlying a sequence of alluvial layers.						Length (m)	30
						Width (m)	6
						Avg. depth (m)	0.4
Context No.	Type	Fill Of	Width (m)	Depth (m)	Description	Finds	Date
6900	Layer			0.22	Ploughsoil. Dark brownish grey clayey silt, firm, no inclusion visible.		
6901	Cut		0.93	0.47	Ditch		
6902	Fill	6901	0.93	0.35	Secondary Fill. Dark grey silt clay.	CBM	Post-medieval
6903	Fill	6901	0.71	0.22	Secondary Fill. Dark grey silt clay with orange flecks.		
6904	Layer			0.25	Alluvial Layer. Firm mid brownish grey silty clay.		
6905	Layer			0.48	Alluvial Layer. Firm to stiff dark bluish grey and mid brownish red oxidised silty clay		
6906	Layer			0.16	Alluvial Layer. Firm to stiff dark bluish grey and dark grey silty clay.		
6907	Layer			0.3	Alluvial Layer. Firm light brownish red and light greyish blue clayey silt.		
6908	Layer				Alluvial Layer. Soft to very soft mid bluish grey and mid greyish red clayey silt		
<b>Trench 70</b>							
General description						Orientation	N-S
Trench devoid of archaeology. Consists of ploughsoil overlying a sequence of alluvial layers, with an organic buried soil between these.						Length (m)	30
						Width (m)	6
						Avg. depth (m)	2
Context No.	Type	Fill Of	Width (m)	Depth (m)	Description	Finds	Date
7000	Layer			0.26	Ploughsoil. Dark greyish brown clayey silt loam		
7001	Layer			0.25	Alluvial Layer. Mid yellowish brown silty clay. Overlies alluvial layer (7002).		
7002	Layer			0.34	Alluvial Layer. Mid greyish brown silty clay. Overlies alluvial layer (7003).		
7003	Layer			0.16	Alluvial Layer. Mid greyish brown silty clay containing rip up clasts from underlying organic layer. Overlies buried soil (7004).		
7004	Layer			0.03	Buried soil. Dark greyish brown to black clayey silt. Thin peat	Bone	

					deposit. Overlies alluvial layer (7005).		
7005	Layer			0.36	Alluvial Layer. Mid greyish brown silty clay. Overlies alluvial layer (7006).		
7006	Layer			0.24	Alluvial Layer. Soft, mid brownish grey silty clay. Overlies alluvial layer (7007).		
7007	Layer				Alluvial Layer. Soft, organic-rich mid blueish grey silty clay		
<b>Trench 71</b>							
General description						Orientation	N-S
Trench devoid of archaeology. Consists of ploughsoil and interface context overlying a deep sequence of alluvial layers. Possible stabilisation layer shown in northern end of trench.						Length (m)	30
						Width (m)	6
						Avg. depth (m)	2
Context No.	Type	Fill Of	Width (m)	Depth (m)	Description	Finds	Date
7100	Layer			0.37	Ploughsoil. Dark greyish brown compact clayey silt.		
7101	Layer			0.33	Alluvial Layer. Mid yellowish brown silty clay. Firm. Overlies alluvial layer (7102).		
7102	Layer			0.6	Alluvial Layer. Mid grey silty clay. Firm. Sandy lamination throughout. Overlies alluvial layer (7103).		
7103	Layer			0.27	Alluvial Layer. Mid grey silty clay with common mottling. Firm and stoneless. Sandy lamination throughout. Overlies alluvial layer (7104).		
7104	Layer				Alluvial Layer. Dark grey soft clay silt. Rare organic inclusions. Overlies alluvial layer (7105).		
7105	Layer			0.22	Alluvial Layer. Mid grey with abundant yellowish red mottling. (Overlies alluvial layer (7106)).		
7106	Layer			0.23	Alluvial Layer. Mid grey silty clay with common reddish mottling, Possible upper oxidised part of 7102. Overlies alluvial layer (7107).		
7107	Layer			0.15	Alluvial Layer. Dark grey clay rare pale yellowish mottling. Overlies alluvial layer (7108).		
7108	Layer			0.22	Alluvial Layer. Mid to light blueish grey silty clay		
<b>Trench 72</b>							
General description						Orientation	E-W
Trench devoid of archaeology. Consists of ploughsoil overlying a deep sequence of alluvial layers. Augered to a total of 6.75m bpgl and still natural geology not reached.						Length (m)	30
						Width (m)	6
						Avg. depth (m)	2

Context No.	Type	Fill Of	Width (m)	Depth (m)	Description	Finds	Date
7200	Layer			0.22	Ploughsoil. Dark greyish brown clayey silt loam		
7201	Layer			0.43	Alluvial Layer. Mid yellowish brown silty clay. Overlies alluvial layer (7202).		
7202	Layer			0.39	Alluvial Layer. Compact, stiff, mid brownish grey silty clay. Overlies alluvial layer (7203).		
7203	Layer			0.4	Alluvial Layer. Firm but pliable dark yellowish brown silty clay. Overlies alluvial layer (7204).		
7204	Layer			0.42	Alluvial Layer. Soft, pliable mid greyish brown silty clay. Overlies alluvial layer (7205).		
7205	Layer				Alluvial Layer. Organic-rich soft, pliable, mid to light blueish grey silty clay. Overlies alluvial layer (7206).		
7206	Layer			0.09	Alluvial Layer. Dark greyish black Peaty clay alluvium, 30% organic material. Overlies alluvial layer (7207).		
7207	Layer			0.64	Alluvial Layer. Light greyish blue clayey silt with lenses of sand towards the base of context. Overlies alluvial layer (7208).		
7208	Layer			2.36	Alluvial Layer. Light bluish grey sandy silt. Laminated alternate lenses of sand and silt.		

### Trench 73

Context No.	Type	Fill Of	Width (m)	Depth (m)	Description	Finds	Date
General description						Orientation	NNW-SSE
Trench devoid of archaeology. Consists of ploughsoil overlying sequences of alluvium and peat between these.						Length (m)	30
						Width (m)	6
						Avg. depth (m)	2
7300	Layer			0.14	Ploughsoil. Dark brownish grey, compact clayey silt.		
7301	Layer			0.36	Alluvial Layer. Light grey silty clay with common pale yellowish mottling, firm. Overlies alluvial layer (7302).		
7302	Layer		6	0.38	Alluvial Layer. Mid grey silty clay with reddish mottling, firm and stoneless. Overlies buried soil (7303).		
7303	Layer			0.15	Buried soil. Black humic clayey silt, soft. Overlies alluvial layer (7304).		
7304	Layer			0.15	Alluvial Layer. Light bluish grey silty clay with yellowish mottling, soft. Overlies alluvial layer (7305).		

7305	Layer			0.53	Alluvial Layer. Mid greyish brown silty clay with common reddish mottling, soft. Overlies alluvial layer (7306).		
7306	Layer				Alluvial Layer. Mid bluish grey silty clay with organic material, soft.		

#### Trench 74

General description					Orientation	E - W
Trench devoid of archaeology. Consists of ploughsoil overlying a deep sequence of alluvial layers with humic buried soil between these.					Length (m)	30
					Width (m)	6
					Avg. depth (m)	2

Context No.	Type	Fill Of	Width (m)	Depth (m)	Description	Finds	Date
7400	Layer			0.25	Ploughsoil. Dark greyish brown silty clay, firm		
7401	Layer				Alluvial Layer. Light grey mottled orange, silty clay, stiff. Overlies alluvial layer (7402).		
7402	Layer				Alluvial Layer. Greyish orange clayey silt. Overlies buried soil (7403).		
7403	Layer				Buried soil. Dark greyish brown sandy silt. Overlies alluvial layer (7404).		
7404	Layer				Alluvial Layer. Light grey mottled light yellow, silty clay, stiff. Overlies alluvial layer (7405).		
7405	Layer				Alluvial Layer. Reddish grey silty clay, firm. Overlies alluvial layer (7406).		
7406	Layer				Alluvial Layer. Dark blueish grey, silty sand, soft		

#### Trench 75

General description					Orientation	N-S
Trench devoid of archaeology. Consists of ploughsoil overlying sequence of alluvial layers and buried soil between these. Geological natural not reached at 2m.					Length (m)	30
					Width (m)	6
					Avg. depth (m)	2

Context No.	Type	Fill Of	Width (m)	Depth (m)	Description	Finds	Date
7500	Layer			0.2	Ploughsoil. Dark greyish brown clayey silt.		
7501	Layer			0.24	Alluvial Layer. Light grey silty clay with common pale yellowish mottling, firm. Overlies alluvial layer (7502).		
7502	Layer			0.4	Alluvial Layer. Mid brownish grey silty clay with reddish mottling, firm and stoneless. Overlies buried soil (7503).		
7503	Layer			0.28	Buried soil. Black humic clayey silt, soft. Overlies alluvial layer (7504).		

7504	Layer			0.5	Alluvial Layer. Mid grey silty clay with common mottling, soft and stoneless. Overlies alluvial layer (7505).		
7505	Layer				Alluvial Layer. Mid bluish grey silty clay with organic material, soft.		

### Trench 76

General description					Orientation	N-S
Trench devoid of archaeology. Consists of ploughsoil overlying sequence of alluvial layers and buried soil between these. Geological natural not reached at 2m.					Length (m)	30
					Width (m)	6
					Avg. depth (m)	2

Context No.	Type	Fill Of	Width (m)	Depth (m)	Description	Finds	Date
7600	Layer			0.2	Ploughsoil. Dark brownish grey clayey silt		
7601	Void						
7602	Layer			0.42	Alluvial Layer. Mid grey silty clay with pale yellowish mottling, firm and stoneless. Overlies alluvial layer (7603).		
7603	Layer			0.35	Alluvial Layer. Mid brownish grey silty clay with common mottling, firm. Overlies buried soil (7604).		
7604	Layer			0.24	Buried soil. Black humic clayey silt, soft. Overlies alluvial layer (7605).		
7605	Layer			0.64	Alluvial Layer. Mid grey silty clay with common mottling, soft and stoneless. Overlies alluvial layer (7606).		
7606	Layer				Alluvial Layer. Mid bluish grey silty clay with organic material, soft and stoneless.		

### Trench 77

General description					Orientation	
					Length (m)	
					Width (m)	
					Avg. depth (m)	

Context No.	Type	Fill Of	Width (m)	Depth (m)	Description	Finds	Date
-------------	------	---------	-----------	-----------	-------------	-------	------

### Trench 78

General description					Orientation	N-S
Trench devoid of archaeology. Consists of ploughsoil overlying a series of alluvial layers and organic buried soil between these.					Length (m)	30
					Width (m)	6
					Avg. depth (m)	2

Context No.	Type	Fill Of	Width (m)	Depth (m)	Description	Finds	Date
-------------	------	---------	-----------	-----------	-------------	-------	------

7800	Layer			0.34	Ploughsoil. Dark greyish brown clayey silt		
7801	Layer			0.23	Alluvial Layer. Light grey silty clay with frequent pale yellowish and orangish mottling. Overlying alluvial layer (7802).		
7802	Layer			0.35	Alluvial Layer. Mid brownish grey silty clay with occasional orangish mottling. Overlying a peat layer (7803).		
7803	Layer			0.2	Buried soil. Dark brownish black peat overlying an alluvial layer (7804).		
7804	Layer			0.37	Alluvial Layer. Light grey silty clay with common mottling. Overlies alluvial layer (7805)		
7805	Layer				Alluvial Layer. Dark greyish blue silty clay		

### Trench 79

General description						Orientation	N-S
Trench consists of ploughsoil overlying a deep sequence of alluvial layers and organic buried soil between these.						Length (m)	30
						Width (m)	6
						Avg. depth (m)	2

Context No.	Type	Fill Of	Width (m)	Depth (m)	Description	Finds	Date
7900	Layer			0.32	Ploughsoil. Dark greyish brown clayey silt, firm.		
7901	Layer			0.53	Alluvial Layer. Light grey silty clay with common pale yellowish mottling, firm. Overlies alluvial layer (7902).		
7902	Layer			0.15	Alluvial Layer. Mid brownish grey silty clay with reddish mottling, firm and stoneless. Overlies buried soil (7903).		
7903	Layer			0.29	Buried soil. Black humic clayey silt, soft. Overlies alluvial layer (7904).		
7904	Layer			0.2	Alluvial Layer. Mid grey silty clay with common mottling, soft and stoneless. Overlies alluvial layer (7905).		
7905	Layer				Alluvial Layer. Light greyish blue silty clay with organic material, soft.		

### Trench 80

General description						Orientation	E-W
Trench consists of ploughsoil overlying a deep sequence of alluvial layers and buried soil between these. Trench devoid of archaeology.						Length (m)	30
						Width (m)	6
						Avg. depth (m)	2

Context No.	Type	Fill Of	Width (m)	Depth (m)	Description	Finds	Date
8000	Layer			0.32	Ploughsoil. Dark grey clayey silt		



8001	Layer			0.49	Alluvial Layer. Light grey silty clay with frequent yellowish and orangish mottling, firm. Overlies alluvial layer (8002).		
8002	Layer			0.44	Alluvial Layer. Mid brownish grey silty clay with common mottling, firm. Overlies buried soil (8003).		
8003	Layer			0.3	Buried soil. Black humic clayey silt, soft. Overlies alluvial layer (8004).		
8004	Layer			0.4	Alluvial Layer. Mid grey silty clay with common mottling, soft. Overlies alluvial layer (8005).		
8005	Layer				Alluvial Layer. Light greyish blue silty clay with organic material, soft.		

### Trench 81

General description					Orientation	E-W
Trench devoid of archaeology. Consists of ploughsoil overlying sequence of alluvial layers and buried soil between these.					Length (m)	30
					Width (m)	6
					Avg. depth (m)	2

Context No.	Type	Fill Of	Width (m)	Depth (m)	Description	Finds	Date
8100	Layer			0.3	Ploughsoil. Dark greyish brown clayey silt, firm.		
8101	Layer			0.4	Alluvial Layer. Light grey silty clay with common pale yellowish mottling, firm. Overlies alluvial layer (8102).		
8102	Layer			0.37	Alluvial Layer. Mid brownish grey silty clay with reddish mottling, firm and stoneless. Overlies buried soil (8103).		
8103	Layer			0.29	Buried soil. Black humic clayey silt, soft. Overlies alluvial layer (8104).		
8104	Layer			0.45	Alluvial Layer. Mid grey silty clay with common mottling, soft and stoneless. Overlies alluvial layer (8105).		
8105	Layer			0.35	Alluvial Layer. Mid bluish grey silty clay with organic material, soft and stoneless.		
8106	Void						

### Trench 82

General description					Orientation	N-S
Trench consists of ploughsoil overlying a sequence of alluvial layers and organic buried soil between these. No archaeology present.					Length (m)	30
					Width (m)	6
					Avg. depth (m)	2

Context No.	Type	Fill Of	Width (m)	Depth (m)	Description	Finds	Date
-------------	------	---------	-----------	-----------	-------------	-------	------

8200	Layer			0.32	Ploughsoil. Dark greyish brown clayey silt, firm.		
8201	Layer			0.44	Alluvial Layer. Mid grey silty clay with orangish mottling, firm. Overlies alluvial layer (8202).		
8202	Layer			0.3	Alluvial Layer. Mid brownish grey silty clay with common pale yellowish mottling, firm. Overlies buried soil (8203).		
8203	Layer			0.3	Buried soil. Black humic clayey silt, soft. Overlies alluvial layer (8204).		
8204	Layer			0.4	Alluvial Layer. Mid grey silty clay with common mottling, soft. Overlies alluvial layer (8205).		
8205	Layer				Alluvial Layer. Light greyish blue silty clay with organic material, soft.		

### Trench 83

General description						Orientation	N-S
Trench consists of ploughsoil overlying a series of alluvial layers.						Length (m)	30
						Width (m)	6
						Avg. depth (m)	2

Context No.	Type	Fill Of	Width (m)	Depth (m)	Description	Finds	Date
8300	Layer			0.28	Ploughsoil. Dark greyish brown clayey silt, firm.		
8301	Layer			0.51	Alluvial Layer. Dark reddish brown clayey silt. Overlies alluvial layer (8302).		
8302	Layer			0.21	Alluvial Layer. Light blueish grey silty clay. Overlies buried soil layer (8303).		
8303	Layer			0.15	Buried soil. Dark brownish black peat. Overlies alluvial layer (8304).		
8304	Layer			0.67	Alluvial Layer. Light brownish grey silty clay. Overlies alluvial layer (8305).		
8305	Layer				Alluvial Layer. Light greyish blue silty clay		

### Trench 84

General description						Orientation	E-W
Trench consists of ploughsoil overlying sequence of alluvial layers and organic buried soil between these. No archaeology present.						Length (m)	30
						Width (m)	6
						Avg. depth (m)	2

Context No.	Type	Fill Of	Width (m)	Depth (m)	Description	Finds	Date
8400	Layer			0.4	Ploughsoil. Dark grey clayey silt		
8401	Layer			0.4	Alluvial Layer. Light grey silty clay with frequent yellowish and orangish mottling, firm. Overlies alluvial layer (8402).		

8402	Layer			0.25	Alluvial Layer. Mid brownish grey silty clay with occasional mottling, firm. Overlies burial soil (8403).		
8403	Layer			0.16	Buried soil. Black humic clayey silt, soft. Overlies alluvial layer (8404).		
8404	Layer			0.49	Alluvial Layer. Mid grey silty clay with reddish mottling, soft. Overlies alluvial layer (8405).		
8405	Layer				Alluvial Layer. Light greyish blue silty clay with organic material, soft.		

### Trench 85

General description						Orientation	NW-SE
Devoid of archaeology. Topsoil onto two alluvial subsoils, a buried soil layer and then a final two alluvial subsoils. Test pit to 3m. Recorded at the SE end of trench						Length (m)	30
						Width (m)	6
						Avg. depth (m)	3
Context No.	Type	Fill Of	Width (m)	Depth (m)	Description	Finds	Date
8500	Layer		6	0.3	Topsoil. Dark greyish brown loam.		
8501	Layer		6	0.3	Alluvial Layer. Mid greyish brown compact clay with little to no inclusions. Overlies alluvial layer (8502).		
8502	Layer		6	0.3	Alluvial Layer. Mottled mid orangish brown and mid greyish blue compact clay with little to no inclusions. Overlies buried soil (8503).		
8503	Layer		6	0.1	Buried soil. Dark greyish brown loam. Overlies alluvial layer (8504).		
8504	Layer		2	0.5	Alluvial Layer. Mid greyish blue compact clay with occasional mottling of mid greyish brown compact clay. No inclusions. Overlies alluvial layer (8505).		
8505	Layer		2	0.5	Alluvial Layer. Dark greyish blue compact clay with little to no inclusions. Overlies alluvial layer (8506).		
8506	Layer				Alluvial Layer. Blue grey clay silt. Laminated.		

### Trench 86

General description						Orientation	E-W
Trench devoid of archaeology. Consists of ploughsoil overlying a deep sequence of alluvial deposits and a buried soil (buried soil only present at western end of trench). Excavated to a max depth of 2m.						Length (m)	30
						Width (m)	6
						Avg. depth (m)	2
Context No.	Type	Fill Of	Width (m)	Depth (m)	Description	Finds	Date

8600	Layer			0.26	Ploughsoil. Dark greyish brown clayey silt		
8601	Layer			0.2	Alluvial Layer. Light brown silty clay with common pale yellowish mottling, firm. Overlies alluvial layer (8602).		
8602	Layer			0.46	Alluvial Layer. Mid brownish grey silty clay with reddish mottling, firm and stoneless. Overlies buried soil (8603).		
8603	Layer			0.14	Buried soil. Black humic clayey silt, soft (only present at western end of trench). Overlies alluvial layer (8604).		
8604	Layer			0.5	Alluvial Layer. Mid grey silty clay with common mottling, soft and stoneless. Overlies alluvial layer (8605).		
8605	Layer				Alluvial Layer. Mid bluish grey silty clay with organic material, soft and stoneless		
<b>Trench 87</b>							
General description						Orientation	N-S
Trench devoid of archaeology. Consists of ploughsoil overlying a series of alluvial layers						Length (m)	30
						Width (m)	6
						Avg. depth (m)	2
Context No.	Type	Fill Of	Width (m)	Depth (m)	Description	Finds	Date
8700	Layer			0.32	Ploughsoil. Dark greyish brown clayey silt, firm.		
8701	Layer			0.46	Alluvial Layer. Mid greyish brown clayey silt. Overlies alluvial layer (8702).		
8702	Layer			0.65	Alluvial Layer. Mid greyish brown silty clay. Overlies alluvial layer (8703).		
8703	Layer				Alluvial Layer. Dark greyish blue silty clay		
<b>Trench 88</b>							
General description						Orientation	ENE-WSW
Trench devoid of archaeology. Consists of ploughsoil overlying several alluvial layers						Length (m)	30
						Width (m)	6
						Avg. depth (m)	2
Context No.	Type	Fill Of	Width (m)	Depth (m)	Description	Finds	Date
8800	Layer		2	0.3	Topsoil. Dark greyish brown loam		
8801	Layer		2	0.26	Alluvial Layer. Mid greyish brown compact clay with little to no inclusions.		
8802	Layer		2	0.12	Alluvial Layer. Mottled mid orangish brown and mid greyish		

					blue compact clay with little to no inclusions.		
8803	Layer		2	0.93	Alluvial Layer. Mid greyish blue compact clay with occasional mottling of mid orangish brown compact clay. No inclusions.		
8804	Layer		2	0.39	Alluvial Layer. Dark greyish blue compact clay with frequent manganese flecks.		

### Trench 89

General description						Orientation	N-S
Trench devoid of archaeology. Consists of ploughsoil overlying a deep sequence of alluvial deposits as well as a possible buried soil. Excavated to a max depth of 2m.						Length (m)	30
						Width (m)	6
						Avg. depth (m)	2
Context No.	Type	Fill Of	Width (m)	Depth (m)	Description	Finds	Date
8900	Layer			0.3	Ploughsoil. Mid greyish brown clayey silt		
8901	Layer			0.32	Alluvial Layer. Light brown silty clay with common pale yellowish mottling, firm. Overlies alluvial layer (8902).		
8902	Layer			0.44	Alluvial Layer. Mid brownish grey silty clay with reddish mottling, firm and stoneless. Overlies buried soil (8903).		
8903	Layer			0.08	Buried soil. Black humic clayey silt, soft. Overlies alluvial layer (8904).		
8904	Layer			0.5	Alluvial Layer. Mid grey silty clay with common mottling, soft and stoneless. Overlies alluvial layer (8905).		
8905	Layer				Alluvial Layer. Mid bluish grey silty clay with organic material, soft and stoneless		

### Trench 90

General description						Orientation	E-W
Trench devoid of archaeology. Topsoil overlying alluvial layers						Length (m)	30
						Width (m)	2
						Avg. depth (m)	2
Context No.	Type	Fill Of	Width (m)	Depth (m)	Description	Finds	Date
9000	Layer		6	0.28	Ploughsoil. Dark greyish brown loam.		
9001	Layer			0.3	Alluvial Layer. Mid greyish brown compact clay with little to no inclusions. Overlies alluvial layer (9002).		
9002	Layer		2	0.44	Alluvial Layer. Mottled mid orangish brown and mid greyish blue compact clay with little to		

					no inclusions. Overlies alluvial layer (9003).		
9003	Layer		2	0.5	Alluvial Layer. mid orangish brown compact clay with very frequent manganese inclusions. Overlies alluvial layer (9004).		
9004	Layer		2		Alluvial Layer. Mid to dark blue-grey compact clay with no inclusions		
<b>Trench 91</b>							
General description						Orientation	NW-SE
Devoid of archaeology. Consists of ploughsoil overlying alluvial deposits						Length (m)	30
						Width (m)	6
						Avg. depth (m)	2
Context No.	Type	Fill Of	Width (m)	Depth (m)	Description	Finds	Date
9100	Layer		2	0.3	Topsoil. Dark greyish brown loam.		
9101	Layer		2	0.22	Alluvial Layer. Mottled mid greyish blue and mid orangish brown compact clay with little to no inclusions. Overlies alluvial layer (9102).		
9102	Layer		2	0.26	Alluvial Layer. Mid orangish brown compact clay occasionally mottled with mid greyish blue compact clay with little to no inclusions. Overlies alluvial layer (9103).		
9103	Layer		2	0.89	Alluvial Layer. Mid greyish blue compact clay with occasional manganese flecks. Overlies alluvial layer (9104).		
9104	Layer		2	0.33	Alluvial Layer. Dark greyish blue compact clay with frequent manganese flecks.		
<b>Trench 92</b>							
General description						Orientation	NW-SE
Devoid of archaeology. Consists of ploughsoil overlying alluvial deposits. These cover a thin buried soil that overlies further alluvial deposits. Test pit to 3m completed at SE end of trench						Length (m)	30
						Width (m)	6
						Avg. depth (m)	3
Context No.	Type	Fill Of	Width (m)	Depth (m)	Description	Finds	Date
9200	Layer		2	0.3	Ploughsoil. Dark greyish brown clayey silt		
9201	Layer		2	0.3	Alluvial Layer. Mottled mid yellowish brown silty clay with little to no inclusions. Overlies alluvial layer (9202).		
9202	Layer		2	0.36	Alluvial Layer. Mid greyish brown silty clay. Overlies buried soil (9203).		

9203	Layer		2	0.15	Buried soil. Dark greyish brown clayey silt. Overlies alluvial layer (9204).		
9204	Layer			0.4	Alluvial Layer. Mid yellowish brown silty clay. Overlies alluvial layer (9205).		
9205	Layer			0.98	Alluvial Layer. Mid blueish grey silty clay with frequent detrital organic matter. Overlies alluvial layer (9206).		
9206	Layer				Alluvial Layer. Mid to dark blueish grey sandy clay. Seen in 3m test put only		

### Trench 93

General description						Orientation	E-W
Trench devoid of archaeology. Consists of ploughsoil overlying deep sequence of alluvial deposits.						Length (m)	30
						Width (m)	6
						Avg. depth (m)	2
Context No.	Type	Fill Of	Width (m)	Depth (m)	Description	Finds	Date
9300	Layer			0.3	Ploughsoil. Dark greyish brown clayey silt.		
9301	Layer			0.35	Alluvial Layer. Mid grey compact silty clay with frequent yellowish and orangish mottling. Overlies alluvial layer (9302).		
9302	Layer			0.28	Alluvial Layer. Mottled mid brownish grey and mid orangish brown compact silty clay with little to no inclusions. Overlies alluvial layer (9303).		
9303	Layer		6	0.32	Alluvial Layer. Mid grey compact silty clay with occasional mottling with little to no inclusions. Overlies alluvial layer (9304).		
9304	Layer		6	0.75	Alluvial Layer. Dark greyish blue compact silty clay with little to no inclusions.		

### Trench 94

General description						Orientation	
Devoid of archaeology. Consists of ploughsoil overlying alluvial deposits						Length (m)	30
						Width (m)	6
						Avg. depth (m)	2
Context No.	Type	Fill Of	Width (m)	Depth (m)	Description	Finds	Date
9400	Layer			0.32	Ploughsoil. Dark greyish brown		
9401	Layer			0.45	Alluvial Layer. Mid brownish orange clay. Overlies alluvial layer (9402).		
9402	Layer			0.74	Alluvial Layer. Mid blueish grey clay with orange mottling. Overlies alluvial layer (9403).		

9403	Layer				Alluvial Layer. Dark blue clay		
<b>Trench 95</b>							
General description						Orientation	NE-SW
Devoid of archaeology. Consists of ploughsoil overlying a sequence of alluvial deposits						Length (m)	30
						Width (m)	6
						Avg. depth (m)	2
Context No.	Type	Fill Of	Width (m)	Depth (m)	Description	Finds	Date
9500	Layer		6	0.3	Topsoil. Dark greyish brown loam		
9501	Layer		6	0.45	Alluvial Layer. Mottled mid orangish brown and mid greyish blue compact clay with little to no inclusions. Overlies alluvial layer (9502).		
9502	Layer		6	0.5	Alluvial Layer. Mid orangish brown compact clay with occasional mottling of mid greyish blue compact clay. Overlies alluvial layer (9503).		
9503	Layer		2	0.6	Alluvial Layer. Dark greyish blue compact clay with occasional manganese flecks.		
<b>Trench 96</b>							
General description						Orientation	NE-SW
Devoid of archaeology. Consists of ploughsoil overlying a sequence of alluvial deposits						Length (m)	30
						Width (m)	6
						Avg. depth (m)	2
Context No.	Type	Fill Of	Width (m)	Depth (m)	Description	Finds	Date
9600	Layer		6	0.3	Topsoil. Dark greyish brown loam.		
9601	Layer		6	0.3	Alluvial Layer. Mottled mid orangish brown and mid greyish blue compact clay with little to no inclusions. Overlies alluvial layer (9602).		
9602	Layer		6	0.9	Alluvial Layer. Mid orangish brown compact clay with occasional mottling of mid greyish blue compact clay. Overlies alluvial layer (9603).		
9603	Layer		2	0.5	Alluvial Layer. Dark greyish blue compact clay with occasional manganese flecks.		
<b>Trench 97</b>							
General description						Orientation	SW-NE
Trench devoid of archaeology. Consists of ploughsoil overlying alluvium that covers a buried soil, which overlies more alluvium						Length (m)	30
						Width (m)	6
						Avg. depth (m)	2



Context No.	Type	Fill Of	Width (m)	Depth (m)	Description	Finds	Date
9700	Layer			0.3	Ploughsoil. Dark greyish brown clayey silt		
9701	Layer			0.42	Alluvial Layer. Mid grey silt clay. Oxidised. Stoneless and firm. Overlies buried soil (9702).		
9702	Layer			0.23	Buried soil. Dark grey silty clay. Stainless and firm. Overlies buried soil (9703).		
9703	Layer			0.34	Buried soil. Light grey silty clay. Slightly oxidised. Stoneless and firm. Overlies alluvial layer (9704).		
9704	Layer			0.4	Alluvial Layer. Mid blueish grey silty clay. Overlies alluvial layer (9705).		
9705	Layer			1.03	Alluvial Layer. Mid to dark blueish grey silty clay with detrital organic material. Overlies buried soil (9706).		
9706	Layer			0.27	Buried soil. Very dark reddish brown fibrous and spongy peat. Occasional plant fragments. Overlies buried soil (9707).		
9707	Layer			0.3	Buried soil. Very dark brown fibrous and spongy peat. Overlies buried soil (9708).		
9708	Layer			0.48	Buried soil. Very dark reddish brown. Fibrous and spongy. Occasional plant fragments. Overlies buried soil (9709).		
9709	Layer			0.42	Buried soil. Dark brown humic silt. Occasional coarse sand. Rare wood fragments. Spongy. Overlies layer (9710).		
9710	Layer			0.65	Other Layer. Olive grey silty sand. Firm. Overlies layer (9711).		
9711	Layer				Other Layer. Greenish grey sand clay with detritus. Compact.		

### Trench 98

General description					Orientation		
Devoid of archaeology. Consists of ploughsoil overlying a sequence of alluvial deposits.					Length (m)		30
					Width (m)		6
					Avg. depth (m)		2
Context No.	Type	Fill Of	Width (m)	Depth (m)	Description	Finds	Date
9800	Layer			0.3	Topsoil. Mid brownish grey. Clayey silt. Firm.		
9801	Layer			0.4	Alluvial Layer. Light-mid greyish brown. Silty clay. Oxidised. Firm and stoneless. Overlies alluvial layer (9802).		

9802	Layer			0.23	Alluvial Layer. Mid grey silty clay. Firm. Very rare pebbles. Slightly mottled. Overlies buried soil (9803).		
9803	Layer			0.2	Buried soil. Dark grey silty clay. Rare large flint nodules. Firm. Overlies alluvial layer (9804).		
9804	Layer			0.6	Alluvial Layer. Pale reddish yellow clayey silt. Oxidised. Firm and stoneless. Overlies alluvial layer (9805).		
9805	Layer			1.4	Alluvial Layer. Light grey clayey silt. Firm and stoneless. Black organic detritus. Slightly mottled. Overlies buried soil (9806).		
9806	Layer				Buried soil. Dark reddish brown fibrous peat. Spongy. Occasional plant fragments.		
<b>Trench 99</b>							
General description						Orientation	N-S
Devoid of archaeology. Consists of ploughsoil overlying a sequence of alluvial deposits						Length (m)	30
						Width (m)	6
						Avg. depth (m)	2
Context No.	Type	Fill Of	Width (m)	Depth (m)	Description	Finds	Date
9900	Layer			0.35	Topsoil. Very dark greyish brown clayey silt. Firm.		
9901	Layer			0.34	Alluvial Layer. Light grey silty clay. Oxidised. Very rare pebbles. Firm. Overlies buried soil (9902).		
9902	Layer			0.21	Buried soil. Dark grey silty clay. Slightly mottled. Very rare pebbles. Firm. Overlies alluvial layer (9903).		
9903	Layer			0.7	Alluvial Layer. Grey silty clay, oxidised. Firm and stoneless. Overlies alluvial layer (9904).		
9904	Layer			0.2	Alluvial Layer. Light-mid blueish grey clay with black organic detritus. Firm and stoneless.		
<b>Trench 100</b>							
General description						Orientation	NNW-SSE
Trench devoid of archaeology. Consists of ploughsoil overlying a sequence of alluvial layers that cover a thin buried soil. This overlies further alluvial deposits						Length (m)	30
						Width (m)	6
						Avg. depth (m)	2
Context No.	Type	Fill Of	Width (m)	Depth (m)	Description	Finds	Date
10000	Layer			0.26	Ploughsoil. Dark greyish brown fine-grained clayey silt.		
10001	Layer			0.64	Alluvial Layer. Grey silty clay. Oxidised. Firm with rare		

					pebbles. Overlies buried soil (10002).		
10002	Layer			0.15	Buried soil. Dark grey silty clay with very rare pebbles. Slightly mottled. Firm. Overlies alluvial layer (10003).		
10003	Layer			0.45	Alluvial Layer. Mid grey silty clay. Oxidised. Firm and stoneless. Overlies alluvial layer (10004).		
10004	Layer				Alluvial Layer. Mid blueish grey clay silt with black organic detritus. Firm and stoneless.		

### Trench 101

General description						Orientation	E-W
Trench may contain archaeology. Consists of ploughsoil overlying a sequence of alluvial layers.						Length (m)	30
						Width (m)	6
						Avg. depth (m)	2
Context No.	Type	Fill Of	Width (m)	Depth (m)	Description	Finds	Date
10100	Layer			0.3	Ploughsoil. Dark grey clayey silt		
10101	Layer			0.39	Alluvial Layer. Light grey silty clay. Oxidised. Firm and stoneless. Overlies 10102		
10102	Layer			0.25	Buried soil. Dark grey clay silt. Slightly mottled. Firm and stoneless. Overlies alluvium 10103.		
10103	Layer			0.45	Alluvial Layer. Pale reddish yellow, oxidised silty clay. Stoneless and firm.		
10104	Layer			0.32	Alluvial Layer. Light grey silty clay. Common pale reddish mottling. Stoneless and firm.		
10105	Layer				Alluvial Layer. Light blueish grey clay silt with black organic detritus. Firm and stoneless.		
10106	Layer		1.3	0.1	Alluvial Layer. Natural layer of flint, possibly a surface of some sort. No visible cut or worked flint.		
10107	Layer			0.29	Alluvial Layer. Dark bluish grey clayey silt with black organic detritus.		
10108	Layer			1.15	Buried soil. Dark yellowish brown peat with frequent wood remains.		

### Trench 102

General description						Orientation	SW - NE
Trench devoid of archaeology. Consists of ploughsoil overlying a deep sequence of alluvial layers with humic buried soil between these.						Length (m)	30
						Width (m)	6
						Avg. depth (m)	2

Context No.	Type	Fill Of	Width (m)	Depth (m)	Description	Finds	Date
10200	Layer		6	0.25	Ploughsoil. Dark greyish brown silty clay, firm		
10201	Layer			0.2	Alluvial Layer. Light grey mottled orange silty clay, stiff. Overlies alluvial layer (10202).		
10202	Layer			0.25	Alluvial Layer. Grey silty clay. Oxidised. Firm and stoneless. Overlies alluvial layer (10203).		
10203	Layer			0.3	Alluvial Layer. Grey silty clay. Firm and stoneless. Overlies alluvial layer (10204).		
10204	Layer			0.1	Buried soil. Very dark grey clay silt. Slightly mottled. Humic. Overlies alluvial layer (10205).		
10205	Layer			0.4	Alluvial Layer. Mid grey silty clay. Yellow mottling and reddish mottling. Firm and stoneless. Overlies alluvial layer (10206).		
10206	Layer				Alluvial Layer. Dark blueish grey, clayey silt, soft. occasional blackorganic detritus.		
<b>Trench 104</b>							
General description					Orientation	NW - SE	
Trench devoid of archaeology. Consists of ploughsoil overlying a deep sequence of alluvial layers with humic buried soil between these.					Length (m)	30	
					Width (m)	6	
					Avg. depth (m)	2	
Context No.	Type	Fill Of	Width (m)	Depth (m)	Description	Finds	Date
10400	Layer		6	0.36	Ploughsoil. Dark greyish brown silty clay, firm		
10401	Layer			0.28	Alluvial Layer. Light grey mottled orange silty clay, stiff. Overlies alluvial layer (10402).		
10402	Layer			0.36	Alluvial Layer. Light grey silty clay. Common mottling. Firm and stoneless. Overlies buried soil (10403).		
10403	Layer			0.16	Buried soil. Dark greyish brown humic silt. Soft and stoneless. Overlies alluvial layer (10404).		
10404	Layer			0.45	Alluvial Layer. Light grey mottled light yellow, silty clay, firm. Overlies alluvial layer (10405).		
10405	Layer			0.3	Alluvial Layer. Mid blue grey clay silt. Common black organic detritus. Firm and stoneless.		

## Appendix B Finds Reports

---

### B.1 Flint

By Lawrence Billington

#### Introduction

- B.1.1 A very small assemblage of five worked flints and a single fragment of burnt flint was recovered from the evaluation. The flints were catalogued directly onto an Excel spreadsheet and the artefacts were classified according to a system of broad artefact/debitage types based on standard definitions for post-glacial lithic assemblages from southern Britain (eg Bamford 1985, 72-77; Butler 2005; Ballin 2021). Additional information on selected non-metric attributes of the material (including extent of dorsal cortex coverage, breakage and condition) was also recorded using standard classifications and terminology, alongside free text notes where appropriate.

#### Trench 3

- B.1.2 Two worked flints, a relatively large hard-hammer struck decortication/core trimming flake (SF 2) and a non-cortical flake fragment (SF 3), were collected from the top of peat deposit 305, alongside a single small unworked burnt flint spall (<1g). Both pieces were in good condition but were affected by a matt 'jet' black surface staining/patina of the kind sometimes associated with flint which has been in contact with organic sediments/peat. Neither piece is chronologically diagnostic.

#### Trench 18

- B.1.3 Three worked flints were collected from Trench 18. Two of these, both simple non-cortical flakes, were derived from the ploughsoil (1800) and are in poor condition, with abrasion and edge damage consistent with having seen considerable post-depositional disturbance. The third piece derived from alluvial layer 1804 and is in good, fresh, condition. It is the broken proximal end of a blade-like flake (on bullhead flint) of probable Mesolithic or earlier Neolithic date.

#### Discussion

- B.1.4 This very small assemblage is of limited significance, but it does highlight the potential for *in situ* or relatively undisturbed prehistoric lithic scatters to survive in buried soils/alluvial deposits in parts of the site.

## B.2 Ceramic Building Material

By Kirsty Smith

### Introduction

B.2.1 A small quantity of ceramic building material (CBM) was recovered from the evaluation amounting in total to 2 fragments weighing 544g. The CBM assemblage comprises two fairly large fragments, one medieval/post-medieval peg tile (179g) and one early post-medieval brick (365g). The assemblage has been spot dated and recorded on an Excel spreadsheet in accordance with guidelines set out by the Archaeological Ceramic Building Materials Group (ACBMG 2007). Fabrics were characterised on the basis of macroscopic features supplemented by the use of x20 hand lens for finer constituents. Where possible, fabrics have been allocated to Museum of London (MoL) fabric codes (MoLA2014).

### Fabrics

B.2.2 The peg tile was made in a hard, orange - pink fine sandy fabric with abundant mica and occasional red iron oxides that equates to MoL fabric 2276, which is dated in London to 1480-1800.

B.2.3 The brick fabric is a dark red coarse sandy clay with occasional silty yellow inclusions, red iron oxides and black iron oxides. This equates to MoL 3033 fabric, dated to 1450-1700 (mostly Tudor). At this site this fabric probably represents local production, possibly supplying a single building event.

### Description

B.2.4 The CBM from this area amounted to one fragment of peg tile (179g) from context 6902 and one fragment of brick (365g) from context 6207. Both of these fragments came from the fills of ditches (6901, 6206).

B.2.5 The medieval/post-medieval fragment of peg tile from context 6902 was 12mm thick with a two edges and a corner surviving. It has one complete peg hole (13mm diameter) which is 27mm and 33mm from the edges. The remnant of a second peg hole survived along a broken edge, set 45mm from the other hole.

B.2.6 The early post-medieval brick fragment from context 6207 had a complete thickness of 41mm thick [ $1\frac{5}{8}$  inches] and was 70+mm wide and 80+mm long. It had one rough side edge and one rough end edge surviving. The brick is slightly thin for a Tudor brick as these are usually 2-2¼ inches thick, but fabric MoL3033 does tend to have an early post-medieval date. It is possible the brick was associated with a nearby farmstead dating to 1450-1700.

### Conclusions

B.2.7 The CBM assemblage by itself is not particularly significant, although these do provide dating evidence for ditches 6206 and 6901. The absence of larger quantities of similar material from elsewhere within the site suggests that these artefacts were transported into site rather than being suggestive of the presence of a building nearby.

## **Recommendations regarding the conservation, discard and retention of material**

- B.2.8 The value of the assemblage is in providing dating evidence for two features and for suggesting the presence of a nearby early post-medieval structure. The assemblage is very small and the fabrics are well-known and the material is unlikely to relate to a building located on the site. It is recommended that the material may be discarded prior to deposition of the archive subject to agreement with the receiving museum.

### C.1 Environmental Samples

By Sharon Cook

#### Introduction

C.1.1 Thirty samples were taken during the evaluation following national guidelines (Historic England 2011). The samples came from potential alluvial layers and buried soils within Trenches 3, 5, 62, 67 and 101.

C.1.2 Four samples were taken for the recovery of charred plant remains (CPR), bones and artefacts, while five samples were taken for the retrieval and assessment of waterlogged plant remains (WPR), insects and mineralised plant remains (MPR), and to establish the potential for preservation of these on site.

#### Method

C.1.3 The bulk samples taken for the recovery of charred and waterlogged plant remains were described and those deposits that were not thought to be waterlogged when excavated (CPR samples) processed in their entirety at Oxford Archaeology East using a modified Siraf-type water flotation machine to 250µm (flot) and 500µm mesh (residue). The residue fractions were sorted by eye and scanned with a magnet for recovery of hammscale. All bones and artefacts were removed and passed to the relevant specialists. The flot material was scanned using a low power (x10) binocular microscope. All identifications are currently provisional, but nomenclature of plant material follows Stace (2010).

C.1.4 For those samples from organic or alluvial layers which were taken primarily for the recovery of waterlogged plant materials (WPR samples), 1L was processed at Oxford Archaeology South using the washover method. The flots and residues were collected in 250µm meshes and kept wet to facilitate preservation. The flot material was scanned using a low power (x10-x40) binocular microscope to identify any plant and other quantifiable remains, while a subsample of each residue was scanned to identify the potential for mineralisation.

C.1.5 Two of the samples taken for CPR were assessed by the processing team as likely to include WPR (samples 27 & 28), and for these a subsample was taken and processed as above for WPR, with the remainder of the sample processed as for CPR. Sample 30 was determined to include waterlogged material after processing and in this case both residue and flot was retained wet to preserve the waterlogged components.

C.1.6 Identification of wild plant remains is with reference to the Digital Seed Atlas of the Netherlands (Cappers *et al.* 2012) and by comparison with modern reference material. Classification and nomenclature of plant material follows Stace (2010).

#### Results

C.1.7 A summary of the samples is presented in Tables 1 and 2, the result of the assessment is presented in Tables 3 and 4.



### **Charred remains**

- C.1.8 The samples produced almost no charred plant remains. Charcoal fragments <2mm are present within a small number of samples but are unsuitable for further work.

### **Waterlogged remains**

- C.1.9 There is considerable variation in the contents of the flots with sample 1 containing almost no plant remains, while in sample 15 the organic material comprises almost the entirety of the processed volume. Waterlogged seeds are rare in all flots apart from sample 30, however the abundance of seeds within this sample is more likely to reflect its much larger volume. No molluscs are present and while many samples include some insect remains, they are infrequent and generally highly fragmented.
- C.1.10 **Trench 3.** Samples 14 (304), 15 (305), 27 (305) and 28 (307) originate within Trench 3. While sample 14 consists of root and stem fragments with occasional woody fragments, samples 15, 27 and 28 are from well humified peaty deposits. Few seeds are present.
- C.1.11 **Trench 5.** Sample 23 from Trench 5 also originates within a peat deposit although no preserved seeds are present in the scanned portion of the flot.
- C.1.12 **Trench 62.** The flot from sample 1 is very small with just occasional fragments of root and rare fragments of peaty material.
- C.1.13 **Trench 67.** The flot from sample 19 consists of root and stem fragments and is similar in appearance to sample 14 (Trench 3) although it lacks the woody component. Sample 21, which was taken and processed primarily for CPR retrieval, also appears to include some formerly waterlogged plant remains in the dry flot, with fine roots and stems forming the majority of the flot volume.

### **Discussion and conclusion**

- C.1.14 The samples generally contain little identifiable waterlogged plant material although well-humified peaty sediments, of fairly uniform appearance, are represented in samples across the site from below 1.8m BGL. The few seeds are well preserved indicating that conditions are likely to have remained stable. The flots from samples taken from above this layer comprise degraded rooty and stem material that is likely to derive from the remains of rushes and sedges etc growing in the area.
- C.1.15 While seeds are infrequent, those of celery-leaved buttercup (*Ranunculus sceleratus*), a plant associated with marshy fields, ponds, and streambeds in samples from Trench 3 provides evidence of the marshy nature of the site in this area, as also evidenced by the peaty nature of the deposits and the presence of sedges (*Carex* sp.). Standing water is evidenced by pond weed (*Potamogeton* sp.) and duckweed (*Lemna* sp) in sample 30 (Trench 101).
- C.1.16 Plants such as brambles (*Rubus* sp.), docks (*Rumex* sp.) and nettles (*Urtica dioica*) are common in neglected areas although their presence may indicate some disturbance of the soil.

### **Recommendations for retention/dispersal**

- C.1.17 While the samples have proved to be relatively poor in identifiable plant remains and insect remains the flots warrant retention until all works on site are complete.

However, it is not anticipated that any further analysis will be required and both flots and any retained sediment could be disposed of once all works are complete.

Sample	Context	Depth (BGL)	Trench	Feature/Deposit Type	Soil Description
21	6704		67	Buried soil	Mid greyish brown silty clay
27	305	1.80 - 2.00	3	Buried soil	Dark brown peat
28	307	1.08 - 1.2	3	Layer	Very dark brown peat
30	10102	0.7	101	Buried soil	Light grey silty clay

Table 1: Details of the contexts sampled for charred plant remains

Sample	Context	Depth (BGL)	Trench	Feature/Deposit Type	Soil Description
1	6203	1.00	62	Buried soil.	10YR 4/2 dark greyish brown clay loam.
14	304	1.85	3	Layer	10YR 5/1 grey silty clay
15	305	2.00	3	Buried soil	10YR 2/1 black silty clay
19	6706	1.75	67	Layer	10YR 5/2 greyish brown clay
23	507	3.50	5	Buried soil	10YR 2/2 very dark brown peat

Table 2: Details of the contexts sampled for waterlogged remains

Sample	Context	Sample Vol (L)	Flot Vol (ml)	Date	Charcoal (>2mm)	Grain	Chaff	Seeds	Molluscs	Other	Notes
21	6704	30	30		+						Rooty flot with very little CPR. Possible waterlogging with occasional uncharred <i>Chenopodium</i> sp. and abundant uncharred <i>Juncus</i> sp. seeds.
27	305	24	100								Almost no CPR. Small flecks of charcoal <2mm only. See WPR table for other details.
28	307	24	400								Almost no CPR. Small flecks of charcoal <2mm only. See WPR table for other details.
30	10102	24	15								Rare charcoal fragments <2mm. See WPR table for details.

Table 3: Assessment of charred plant remains

Key: + 1-4, ++ 5-24, +++ 25-49, ++++ 50-99, +++++ 100+

Sample No	Context No	Sample Vol (L)	Flot Vol (ml)	Date	Wood	Insect	Fruit/Nut	Seeds	Mineralised	Charred	Molluscs	Other	Notes
1	6203	1	<1										Small flot of occasional fine roots and fragments of peaty material.
14	304	1	50		+	++		++					Fine highly fragmented fibrous plant material (stems, roots etc). Occasional soft, small, woody frags. Occasional highly fragmented insect remains including beetle elytra. Seeds infrequent and mainly <i>Ranunculus sceleratus</i> . Rare frags may be from larger seeds. V. rare <i>Rumex</i> sp., and <i>Carex</i> sp.
15	305	1	100 0		+++ ++			+					Part Scanned only (50ml). A peaty flot comprising degraded woody frags and decayed organic material. Stem and root frags. Some twigs and roundwood. Rare modern looking roots. Rare <i>Carex</i> sp.
19	6706	1	40			++		+					Fine highly fragmented fibrous plant material (stems, roots etc). Occasional highly fragmented insect remains including beetle elytra. Single <i>Ranunculus acris/repens/bulbosus</i> .
23	507	1	400		+	++							Peaty flot, mostly degraded woody frags and decayed organic material. Occasional soft, small, woody frags. Occasional highly fragmented insect remains
27	305	1	400			+		++		+			Part Scanned (50ml). A peaty flot comprising decayed woody frags and decayed organic material. Stem and root frags. Rare charcoal

Sample No	Context No	Sample Vol (L)	Flot Vol (ml)	Date	Wood	Insect	Fruit/Nut	Seeds	Mineralised	Charred	Molluscs	Other	Notes
													<2mm. <i>Lemna</i> sp., <i>Urtica dioica</i> , <i>Rubus</i> sp., <i>Carex</i> sp., and <i>Stellaria media</i> . Occasional highly fragmented insect remains.
28	307	1	180			++		++		+			Part scanned (50ml). A peaty flot comprising soft woody fragments and decayed organic material. Stem and root frags. Rare charcoal <2mm. <i>Ranunculus sceleratus</i> and <i>Ranunculus acris/repens/bulbosus</i> . Occasional highly fragmented insect remains.
30	10102	24	15			++		++ ++					Subsample from CPR Flot. Mostly highly fragmented fibrous plant material (stems, roots etc) Occasional highly fragmented insect remains with occasional small intact specimens. Common small <i>Juncus</i> seeds and occasional <i>Lycopus europaeus</i> , <i>Potamogeton</i> sp., <i>Ranunculus sceleratus</i> and <i>Lemna</i> sp.

Table 4: Assessed remains within the waterlogged samples

Key: + 1-4, ++ 5-24, +++ 25-49, ++++ 50-99, +++++ 100+

## C.2 Animal Bone

By Adrienne Powell

### Introduction

- C.2.1 A small quantity of animal bone in fair-good condition was recovered from only four contexts across the excavated trenches. The remains were identified with the aid of the faunal reference collection at Oxford Archaeology South. Several bones and teeth were measurable and where this has been done the measurements follow Von den Driesch (1976). The remains are detailed below.
- C.2.2 From context 4502, a left sheep/goat humerus shaft (weighing 1g), in very good condition but which had been gnawed, came from a neonatal animal.
- C.2.3 From context 5706, two bones, both in very good condition and weighing a total of 5g. They comprise an unfused sheep/goat first phalange and a complete pig left Metacarpal 2; measurements are GL=56.0mm and Bd 11.3.
- C.2.4 The bone from context 6207 is in moderate condition and weighs 169g in total, with some abrasion and recent fractures present. The remains include a cattle maxillary M3 in full wear and five equid maxillary teeth. The latter include a left P3 or P4 (L=27.0mm, CrH=10.9mm) and a left P3 or P4 (L=27.8mm, Br=26.9mm, CrH=43.6mm) which is unevenly worn with the first two thirds of the tooth is worn at an oblique angle to the last third; the crown height difference between these 2 teeth is too great for them to be likely to have come from the same animal. The equid teeth also include a right P2 (L=35.2mm, CrH=13.0mm) with uneven wear: in this case the central third of the tooth is more worn resulting in a mesial 'hook'. This tooth probably adjoins a right P3 which has recent breaks and is of similar but unmeasurable height. The final equid tooth is a right P3/P4 (L=27.4mm, CrH=43.3mm), which may be from the same animal as the equivalent left tooth of similar height.
- C.2.5 From context 7004, a left cattle scapula in moderate condition but with some superficial cracking and surface exfoliation, weighing 70g. The fragment includes the glenoid and neck but lacks the coracoid.

### Recommendations regarding the conservation, discard and retention of material

- C.2.6 The assemblage has not been fully recorded and should be retained until completion of the project and incorporated into subsequent faunal analyses.

## C.3 Waterlogged Wood

By Damian Goodburn

### Introduction

- C.3.1 This report follows a site visit to examine the exposure of woody materials found on the eroded top of the prehistoric peat beneath the clay-silt alluvium at the site. Specifically, there was a dense exposure of the material found in Trench 3 near the north-west edge of the site. The clearly eroded peat surface lay at c -0.5m OD and the key request was to check for traces of woodworking on the exposed wood.

### Description

- C.3.2 The site team had very carefully cleaned the woody materials exposed on the very level peat surface, so it was relatively easy to see that it had been heavily eroded in most areas in prehistory and then covered by alluvium. The whole surface of the c 27m by 2m wide trench excavated to that depth was examined closely. The two most prominent items were two horizontal sections of logs, both approaching c 400mm across, and both eroded to about half their depth. The north-western and larger of these (Fig. 6, log 308) appeared to be of ash with a flat horizontal eroded surface. Some possible tool marks were visible near the southern trench edge, but on closer examination were seen to be trowel marks from the initial cleaning of the trench. The knot directions showed that the butt end of the tree lay to the north where the ground must have been rising slightly hence the oblique erosion of the stem after it fell. The other item (Fig. 6, 311) was a similar eroded half log that appeared to be of alder. Sections of each log were lifted so the underside could be examined for any possible traces of working, but only the natural bark surfaces were found.
- C.3.3 Both logs were surrounded with flat layers of coarse decayed bark (probably from old alder trees) that had mainly broken into rectangular sections resembling axe-cut woodchips. A small number of decayed branch fragments were also visible.
- C.3.4 The two larger log sections thus appear to be trees of the prehistoric flood plain forest that fell naturally at a time of rapidly rising water levels, such as are quite often found in the flood plain of the greater Thames estuary (Stafford 2012).

### Species Identification

by Julia Meen

- C.3.5 Seventeen pieces of waterlogged wood were collected from the site for species identification. Each piece was thin sectioned using a scalpel on the transverse, radial and tangential planes, mounted onto slides and examined under transmitted light at up to x400 magnification using a Brunel Metallurgical SP-400BD microscope. Species identification was made based on diagnostic anatomical characteristics, as described in Schweingruber (1990). Species identifications are shown in Table 5.

Wood no.	Species
308	<i>Fraxinus excelsior</i>
310	Indet; condition very poor
311	<i>Alnus glutinosa</i>
312	cf Conifer
313	cf Conifer
314	cf Conifer

Wood no.	Species
315	Indet
316	<i>Fraxinus excelsior</i>
317	Indet; condition very poor
318	cf Conifer
319	Indet; condition very poor
320	<i>Fraxinus excelsior</i>
321	<i>Fraxinus excelsior</i>
322	cf Conifer
323	cf <i>Quercus</i> sp.
324	<i>Alnus glutinosa</i>
325	Indet; condition very poor

Table 5: Waterlogged wood species identification

C.3.6 Overall, the condition of the waterlogged wood was poor and in many cases the tissue structure had partially decayed, with the result that diagnostic characteristics had not been preserved and identification was difficult. In five of the wood pieces, preservation was too poor for identification. A further five pieces appeared to be coniferous, and were probably all the same taxon; however no closer identification was possible. Pieces 311 and 324 are alder (*Alnus glutinosa*), a tree that is adapted to grow in wet soils and is often found growing alongside rivers and channels. Pieces 308, 316, 320 and 321 are all ash (*Fraxinus excelsior*), while piece 323 is also a ring-porous taxon, probably oak (*Quercus* sp.)

## C.4 Radiocarbon Dating

by Rebecca Nicholson

### Introduction

- C.4.1 Six samples, one of charcoal, one of waterlogged wood and four subsamples taken from two horizons of peaty sediment were submitted for AMS radiocarbon determination to the Beta Analytic laboratory. The two sediment samples were submitted for paired dating on both the humic (alkali soluble) and humin (alkali insoluble) fractions, so for two submitted samples of bulk peat four dates were obtained. Both peat samples came from monolith sample 29: from the base of the peat horizon, context 305 (sub-sample taken at 170-180mm from the top of the monolith) and from context 307 which represents the interface with the underlying sand (sub-sample taken at 280-290mm from the top of the monolith). The sample of waterlogged wood also came from context 305, but from above the peat sub-sample from that context (sample 22, located at the base of monolith sample 30). It was identified as alder (*Alnus* sp.) by J. Meen.
- C.4.2 The sample of charcoal comprised a small single fragment of probable branchwood from sample 21 context 6704 which was an organic horizon, probably a buried soil, within the upper alluvium which was seen frequently across the site. Context 6704 was also recorded at 330-340mm in monolith sample 3. The charcoal provides a *terminus post quem* date for the buried soil since the origin of the charcoal is unknown and the wood of uncertain age. Given the absence of archaeology in the overlying layers it is thought unlikely that the charcoal derives from a later event.
- C.4.3 The reported results (Table 6) are conventional radiocarbon ages (Stuiver and Polach 1977) and were corrected for total fractionation effects and calibration was performed using OxCal 4.4.4 and INTCAL20 (Bronk Ramsey 2009 with 2021 update, Reimer *et al.* 2020). They are presented below with the end points rounded outwards to 10 years following the recommendations of the 1977 International Radiocarbon conference. Reported results are accredited to ISO/IEC 17025:2005 Testing Accreditation PJLA #59423 standards and all chemistry was performed in the Beta Analytic laboratory. When counting statistics produce sigmas lower than +/- 30 years, a conservative +/- 30 BP has been cited for the result. The reported  $\delta^{13}\text{C}$  values were measured separately in an IRMS (isotope ratio mass spectrometer) and are not the AMS  $\delta^{13}\text{C}$  which would include fractionation effects from natural, chemistry and AMS induced sources. All are within the acceptable range for the material.
- C.4.4 The reliability of the dates contained from the peat were tested using a  $\chi^2$  test on the paired samples (see Tables 7 and 8). Measurements on both fractions proved to be statistically consistent in each case and so a weighted mean value has been calculated for each pair using the R\_combine facility in OxCal prior to calibration. The dates obtained are in stratigraphic order, with the waterlogged wood from context 305 provided a determination of 2030-1780 cal. BC, the underlying peat providing a mean date of 2580-2460 cal. BC and the interface with the sand at the base of the sequence providing a mean date of 2890-2670 cal. BC.



Lab. Ref.	Sample	Context	Depth from top of monolith	Material	Fraction dated	$\delta^{13}\text{C}$ (‰)	Radiocarbon Age (BP)	Calibrated date BC (at 95.4%)
Beta - 614823	29	307	280-290mm	Peat	Alkali soluble	-29.7	4200±30	2900-2840 (27.1%) 2820-2670 (68.4%)
Beta - 614824	29	307	280-290mm	Peat	Alkali insoluble	-27.7	4190±30	2900-2830 (24%) 2820-2660 (71%) 2650-2630 (0.5%)
Beta - 614825	29	305	170-180mm	Peat	Alkali soluble	-29.4	4021±30	2630-2460 (95.4%)
Beta - 614826	29	305	170-180mm	Peat	Alkali insoluble	-28.0	3940±30	2570-2530 (10.2%) 2500-2430 (82.8%) 2330-2300 (2.5%)
Beta - 603775	22	305	n/a	Wood (Alder)		-25.5	3580±30	2030-1870 (90.9%) 1850-1820 (3.4%) 1800-1780 (1.1%)
Beta - 614827	21	6704	n/a	Charcoal		-25.6	2490±30	780-510 (94.2%) 500-480 (1.3%)

Table 6: Radiocarbon sample details and calculated age ranges

		<b>From (cal. BC)</b>	<b>To (cal. BC)</b>	<b>%</b>	<b>From (cal. BC)</b>	<b>To (cal. BC)</b>	<b>%</b>
R_Date LTC12T21 305 170-180mm	alkali soluble	2573	2476	68.3	2622	2467	95.4
R_Date LTC12T21 305 170-180mm	alkali insoluble	2476	2348	68.3	2566	2305	95.4
R_Combine (3980±22 BP)		2570	2460	68.3	2580	2460	95.4

Table 7: Results of paired  $\chi^2$  tests on peat samples from monolith 305 at 170-180mm (end points of the combined date are rounded out by 10 years)

		<b>From (cal. BC)</b>	<b>To (cal. BC)</b>	<b>%</b>	<b>From (cal. BC)</b>	<b>To (cal. BC)</b>	<b>%</b>
R_Date LTC12T21 307 280-290mm	alkali soluble	2886	2703	68.3	2895	2671	95.4
R_Date LTC12T21 307 280-290mm	alkali insoluble	2882	2702	68.3	2891	2640	95.4
R_Combine (4195±22 BP)		2890	2700	68.3	2890	2670	95.4

Table 8: Results of paired  $\chi^2$  tests on peat samples from monolith 307 at 280-290mm (end points of the combined date are rounded out by 10 years)

## C.5 Geoarchaeology

By Thomas Bruce and Liz Stafford

### Introduction

- C.5.1 The geoarchaeological component of the evaluation comprised the targeted recording of sedimentary sequences exposed in trenches to supplement standard archaeological recording. The Lower Thames region has been widely investigated and its Holocene sediments are relatively well understood and in certain respects predictable based on regional models of sea-level change and estuary development throughout the Holocene.
- C.5.2 Following a combined review of previous literature and extant geotechnical data to produce the WSI, the deposits anticipated include intercalated sequences of Holocene freshwater and estuarine clay-silt alluvium and peat, with the potential for Pleistocene terrace gravels (and prehistoric land surfaces) to be buried at shallow depths within the floodplain margins abutting the higher ground. Further into the floodplain the underlying gravel surface dips abruptly to depths in excess of 12m in the southern part of Land Parcel 12.
- C.5.3 As stated in the WSI (OA 2021), the main aims of this investigation relevant to the geoarchaeological recording include:
- determine the degree of complexity of any surviving horizontal or vertical stratigraphy.
  - investigate areas where topography indicates the likelihood of deep deposit sequences for evidence of buried archaeological horizons and palaeoenvironmental sequences.
  - examine and record the extent, character and chronology of the sedimentary sequences, particularly those within and immediately adjacent to floodplains and contained within palaeochannels.
  - use the data obtained to refine existing geoarchaeological deposit models.
- C.5.4 More specific objectives include:
- investigate the fringes of the Thames floodplain where the alluvial and organic waterlogged deposits are shallowest.
  - characterise the environmental sequence present on the floodplain margins in detail and, if possible, date it using scientific techniques, such as radiocarbon dating.
- C.5.5 The area under investigation is situated on the northern floodplain margins of the inner estuary of the River Thames, to the south-east of the village of West Tilbury. It comprises a small wedge of low-lying terrain immediately to the south of the broadly south-facing gravel terraces. Land Parcel 12 extends southwards from Station Road, bounded to the north and north-west by a railway line and by a small watercourse to the east. The floodplain here is used for agriculture and criss-crossed by a series of drainage ditches, having been reclaimed from former salt marsh and tidal creek systems. Two north-south aligned drainage ditches present within site are evidence

of this reclamation and run through the floodplain, with additional drainage ditches at the west and east boundaries of site.

- C.5.6 The BGS maps the underlying bedrock geology as Chalk (Lewes Nodular Chalk Formation, Seaford Chalk Formation and Newhaven Chalk Formation (undifferentiated)) throughout Land Parcel 12, although Thanet Sand is present immediately to the north and north-east, beneath the gravel terraces and beyond the site boundary. Outcrops of Lambeth Group bedrock occur slightly further to the north-west. The mapped superficial geology consists of alluvial clays, silts and sands, with peat deposits intercalated within this alluvium. The terrace gravel deposits located to the north and north-east are Mucking (Taplow) Gravels, with Corbets Tey (Lynch Hill) Gravels further to the east. Head deposits are mapped at the base of these terrace gravel deposits to the north and east but are absent at the base of the Mucking (Taplow) terrace to the north-east.
- C.5.7 The study area has been previously reviewed as part of the scheme-wide Palaeolithic and Quaternary Deposit Model (PQDM) (Wenban-Smith and Bates 2020). Land Parcel 12 falls within PQ-10 and is characterised by Holocene alluvial sediments, consisting of clay/silts and sands, with some intercalated peats. These sediments rest on a series of sands between 0m and -12m OD, which may be Pleistocene in age and form part of the East Tilbury Marshes Gravel or may comprise major Holocene sand bars. An important land surface is likely to have developed at the base of the Holocene sediments and late Upper Palaeolithic remains have been recovered from the base of the alluvium at several sites along the southern side of the Thames floodplain. Taking this into account, the Palaeolithic potential for this area is listed as moderate to high.

### **Holocene geoarchaeological background**

- C.5.8 The Holocene sediments of the Lower Thames consist of complex intercalated sequences deposited in a variety of environments representing variously freshwater alder carr, fen, reedswamp, intertidal salt marsh and mudflats. The sediments have been grouped by Gibbard (1999) into the Tilbury Member and are dominated by peats and clay-silts in the inner estuary, with marine sands recorded near the Isle of Grain and Yantlet Channel and Sea Reach south of Canvey Island. The basis for subdivision of these deposits was established by Devoy during the 1970s (Devoy 1977; 1979; 1980; 1982). Devoy's 'Thames-Tilbury' model used borehole stratigraphies integrated with biostratigraphic studies to infer successive phases of marine transgressions (typified by clay-silt deposition) and regressions (typified by peat formation).
- C.5.9 Devoy's work has resulted in a view of sediment accumulation being controlled within the area by a combination of factors dominated by sea level change and tectonic depression of southern England. However, more recent work (eg Bates 1999; Bates and Barham 1995; Bates and Stafford 2013; Haggart 1995; Sidell *et al.* 2000; Sidell *et al.* 2002; Sidell and Wilkinson 2004) has highlighted several problems suggesting that the model cannot always be easily applied in terms of lithology or age/altitude analysis, particularly at the scale of a single archaeological site. This is in part a reflection of the complex nature of floodplain environments where sequence accumulation may be influenced by very local factors such as proximity to the terrace edge, the presence of tributaries, islands or 'eyots' and areas of impeded drainage. More recently a simplified (tripartite) regional model for floodplain development was

presented by Long (Long *et al.* 2000). A similar cultural landscape model set out by Bates and Whittaker (2004) examined the likely impact of these changes on human activity and provides a useful framework for archaeological investigation. Over the last two decades a large number of detailed site-specific investigations have been undertaken along the Lower Thames, many in association with developer-funded archaeological work on large infrastructure projects, that are beginning to address the complex range of factors responsible for sequence accumulation. It should be noted however, that much of this work has been focussed upstream within the more sheltered part of the inner estuary in east and central London, along tributaries, or at the margins rather than the deeper parts of the floodplain.

- C.5.10 Large-scale geoarchaeological investigations located closer to the marine dominated zone, thereby offer valuable comparative data. Adjacent to the LTC in Essex recent projects include the London Gateway Port Development at Shellhaven (Bates *et al.* 2012; Biddulph *et al.* 2012), the London Distribution Park (Batchelor *et al.* 2014), Tilbury Docks (Schulting 2013) and the new port terminal of Tilbury2 (Batchelor and Young 2017). In Kent, in addition to HS1 through the Ebbsfleet Valley (Bates and Stafford 2013) to the west of the LTC, smaller geoarchaeological investigations to the east around Denton include Dalefield Way (Young 2016), the Lion Business Park (Champness 2006, 2007) and the Denton Relief Road (Priestly-Bell 1999; Weaver 2003). These investigations have demonstrated that Holocene sequences in excess of 15m deep with multiple peat horizons are likely to be preserved in the deeper parts of the floodplain dating back to the early Holocene. The waterlogged floodplain sediments have potential to preserve a range of palaeo-environmental indicators suitable for high resolution landscape reconstruction in terms vegetation patterns, past hydrological regimes, climate and sea-level studies and past human interactions, when accompanied with a robust chronology provided by scientific dating (eg radiocarbon and OSL dating). This includes both the organic peat units representing semi-terrestrial environments and inorganic clays, silts and sands deposited in alluvial and estuarine conditions though the study of pollen, plant remains, insects, molluscs, diatoms, ostracods and foraminifera.
- C.5.11 On the floodplain, the undulating surface of the underlying Pleistocene gravel, a relict feature of the late glacial braided stream systems, may be considered a key archaeological horizon, a buried land-surface dissected by meandering channels, that existed prior to the expansion of wetland environments in the early to middle Holocene. However, semi-terrestrial peats located within the sedimentary stack may also preserved evidence of activity and wetland exploitation, notably *in situ* artefact scatters, burnt mounds and waterlogged wooden structures such as trackways and platforms. Activity associated with estuarine sedimentation may include evidence of local industries such as saltmaking, recorded extensively across the marshes in both Kent and Essex and in the vicinity of the LTC.
- C.5.12 Towards the edges of the floodplain and overlying buried floodplain islands sediment sequences maybe shallower with shifting ecotonal zones (the interface between wet and dry ground) and channel margins acting as a focus for activity. In locations where the underlying gravel surface slopes steeply, such ecotonal zones may have remained relatively static for periods of time before being buried, in such circumstances the potential for multi-period *in situ* remains to be preserved is high.

## Geotechnical data

C.5.13 Extant geotechnical (GI) data examined during the preparation of the WSI consisted of a dense cluster of boreholes at the southern end of the floodplain adjacent to the river Thames (east of Land Parcels 130 and the southern half of Land Parcel 38), and a much smaller number at the north end of Land Parcel 12 with little data in between. Those to the south are in an area of historic landfill, and a section prepared from the borehole logs shows that the floodplain alluvial deposits here are generally from 14m-18m deep. There is peat recorded within many of these boreholes, one horizon occurring at 3m – 6m below the top of the alluvium, and others below 11m – 12m of alluvium, with a third horizon (in one of the deepest sequences) just above the gravel below 19m of alluvium. In the northern area, near the railway line, however, the GI data, which was examined in the WSI for trial trenching (OA 2021, Figs 4a-4c) indicated the gravels surface (and overlying peat deposits) in places to be buried at relatively shallow depths of 2-3m BGL and could potentially be investigated within the scope of the current evaluation trenches.

## Method

C.5.14 The trenches were all entirely or partially excavated to a depth of 2m BGL. Due to the depth of the Holocene sediments the vast majority of trenches were excavated to 2m BGL, although machine excavation ceased at the first archaeological horizon if present within the trench. Hand-augering was carried out in a selection of trenches in the base of excavation where practicable in order to investigate the depth of the underlying gravel surface, and was focused in the northern area of Land Parcel 12 where the gravel surface lay just beneath the base of excavation. It had been planned to excavate bucket-width test pits at either end to a depth of 3m BGL in those trenches close to the floodplain edges to investigate for the presence/absence of archaeological remains at depth, and eight trenches did have a test pit dug at one end to this depth (Fig. 9 Trenches 9, 18, 21, 23, 27, 34, 85 and 92), but the scope of the test pit array was much reduced as a consequence of worsening ground conditions.

C.5.15 Sedimentary sequences from 40 trenches, including 45 sections, were examined and considered broadly representative of the stratigraphy occurring throughout site. These sequences have been arranged into six transects (Transects 1-6), whose locations are shown in Figure 9 and the detail in Figures 10-15, illustrating the extent, depth and complexity of deposits, recovered environmental samples and associated archaeological finds/features. The transects were placed to target sequences occurring on the floodplain margins where sediments are shallower; to investigate potential palaeochannel activity across the floodplain, particularly to the east of site; and to examine the variability of sediments further out into the floodplain. The transects display deposits in depth below ground level (BGL) and in metres Ordnance Datum (m OD) to highlight the depth of key archaeological horizons that may be impacted by construction.

C.5.16 The recording of the sediments comprised the detailed geoarchaeological logging of one or more 1m wide sections in each of the selected trenches. Each section was allocated a section number and located relative to the National Grid and Ordnance Datum. Table 9 summarises the location, elevation and total depth of the sections recorded. The sediment sequences were recorded from ground surface on a geoarchaeological log proforma with each layer allocated a unique context number.

Preliminary interpretations of associated depositional processes were also recorded on the logs.

Trench	Section	Easting	Northing	Elevation	Total Depth
3	300	566901.75	177512.60	1.32	2.58
	301	566901.52	177508.33	-0.43	0.30
5	500	566984.66	177536.45	1.40	5.15
6	600	566899.87	177466.76	1.38	2.30
7	700	566951.34	177518.23	1.23	3.78
	701	566950.36	177534.58	1.33	3.05
9	900	566876.45	177475.61	1.38	1.82
	901	566873.51	177489.26	1.35	3.00
10	1000	566919.82	177452.87	1.32	2.63
12	1200	566934.59	177416.32	1.39	3.05
13	1300	566886.88	177424.06	1.31	3.45
14	1400	566853.26	177463.10	1.36	2.54
	1401	566859.25	177447.63	1.29	2.85
15	1500	566821.31	177442.49	1.30	2.50
16	1600	566847.12	177399.92	1.27	5.39
18	1800	566807.49	177425.06	1.43	4.50
19	1900	566818.32	177360.99	1.32	2.12
21	2100	566773.98	177390.55	1.25	3.00
23	2300	566658.51	177294.90	1.41	3.00
27	2700	566631.29	177253.53	1.37	3.00
34	3400	566776.17	177313.90	1.45	3.00
38	3800	566767.81	177245.53	1.26	2.00
39	3900	566796.75	177270.52	1.39	1.95
41	4100	566781.50	177205.22	1.34	2.10
50	5000	566837.60	177292.56	1.23	1.95
54	5400	566856.45	177267.40	1.23	1.86
58	5800	566848.15	177222.12	1.36	1.94
62	6200	567009.15	177203.46	1.46	2.08
63	6300	566856.93	177186.42	1.44	1.90
67	6700	566899.53	177158.89	1.16	2.30
68	6800	566932.93	177146.37	1.26	1.81
69	6901	566972.08	177155.13	1.40	1.47
70	7000	567021.42	177149.42	1.18	2.05
71	7100	566964.7	177116.56	1.45	2.10
	7101	566966.25	177132.26	1.42	2.25
72	7200	567024.10	177113.92	1.20	6.75
85	8500	567136.61	177237.89	1.32	3.00
92	9200	567188.00	177168.61	1.51	3.00
97	9700	567069.63	177512.365	1.36	5.00
98	9800	567073.95	177464.28	1.44	4.00
99	9900	567087.77	177426.31	1.33	1.90

Trench	Section	Easting	Northing	Elevation	Total Depth
100	10000	567114.40	177365.11	1.36	1.70
101	10100	567120.09	177392.70	1.23	5.20
102	10200	567147.51	177328.63	1.40	2.10
104	10400	567159.76	177290.77	1.36	1.90

Table 9: Summary of geoarchaeological section locations

- C.5.17 Sediment recording followed recommended guidelines (Jones *et al.* 1999; Historic England 2015b), which typically included a description of texture, compaction, colour, clast size and abundance, bedding structures and other inclusions (eg charcoal), post-depositional features (eg rooting, mottling, mineralisation), and the nature of sediment contacts (eg abrupt, diffuse, irregular).
- C.5.18 Sampling of the sediment sequences was carried out in accordance with Historic England guidelines (2011) and was targeted on trenches containing organic-rich and peat deposits identified within the alluvial sequence (Table 10). Monoliths and OSL samples were taken from sequences containing these deposits, allowing for further analysis and dating should this be required. Two gouge auger cores were recovered from the base of Trench 3 to sample the base of the peat but were later superseded by a monolith recovered from a hand-dug test pit close to Section 300 (Section 301, sample <29>).
- C.5.19 Bulk samples were taken from organic-rich, peat and waterlogged deposits mainly for assessment of waterlogged plant remains and molluscs, but also occasionally for charred plant remains and charcoal (CPR). Where sampling was carried out, the log proforma was accompanied by a measured section drawing marking the position of the samples. The OSL and monolith samples have been retained should they be required for further work; the latter have been subsequently subsampled for radiocarbon dating in Trenches 3 and 67 (see Nicholson, Appendix C.4). WPR and CPR samples have been processed and are reported within the environmental section of this report (see Cook, Appendix C.1).
- C.5.20 Following the completion of fieldwork, the lithological information from the logs was inputted into geological modelling software (Rockworks 17) to allow the identification and broad correlation of a series of sediment facies. This enabled the creation of digital transects illustrating the key trench profiles across the site and the location of corresponding samples.

Trench	Sample	Sample type	Section	Context
3	7	Monolith	300	301, 302
3	8	Monolith	300	302
3	9	Monolith	300	303, 304
3	10	Monolith	300	304, 305
3	11	OSL	300	303
3	12	OSL	300	304
3	13	OSL	300	305
3	14	WPR	300	304
3	15	WPR	300	305



Trench	Sample	Sample type	Section	Context
3	22	C14	300	305
3	24	Gouge core	300	305
3	25	Gouge core	300	305
3	27	CPR	301	305
3	28	CPR	301	307
3	29	Monolith	301	305, 307
5	23	WPR	500	507
6	26	Monolith	600	606, 607, 608, 609
62	1	WPR	6200	6203
67	2	Monolith	6700	6700, 6701, 6702
67	3	Monolith	6700	6702, 6703, 6704, 6705
67	4	Monolith	6700	6704, 6705
67	5	Monolith	6700	6705, 6706
67	6	Monolith	6700	6706
67	16	OSL	6700	6703
67	17	OSL	6700	6704
67	18	OSL	6700	6705
67	19	WPR	6700	6706
67	20	WPR	6700	6704
67	21	CPR	6700	6704

Table 10: Summary of samples from the sedimentary sequences

## Results

C.5.21 Overall, several broad sedimentary facies were recorded across the site. The results are presented below and are discussed in relation a series of composite transects incorporating key trench sequences:

- I. **Topsoil** – modern ploughsoils
- II. **Alluvium (clay/silt)** – Holocene deposits produced by flooding/inndation events (freshwater/brackish). Generally stoneless blueish grey, greyish brown and yellowish brown homogenous silty clays / clayey silts with infrequent organic material. Heavily oxidised deposits with signs of bioturbation in upper parts
- III. **Stabilisation/buried soil horizons** – dark greyish brown (organic) horizons mainly <0.2m thick. Humic in places with variable organic content. Limited clast content with abundant evidence of bioturbation (rooting). Frequently occurring intercalated within the upper oxidised alluvium in multiple trenches across the floodplain within 1m of the current ground surface. Radiocarbon dating Trench 67 provided a TPQ in the early Iron Age (see Nicholson this report)
- IV. **Detrital alluvium** – soft blueish grey gleyed silty clays / clayey silts containing frequent detrital organic material. Stoneless and homogenous Holocene deposits resulting from flooding inundation events (freshwater/brackish)
- V. **Laminated alluvium** –Holocene alluvium comprising brownish to blueish grey silty clays with thin (1-2mm) laminated lenses of sand and silt. Largely

stone-free with occasional organic inclusions. Possibly associated with the margins of channels or creek systems

- VI. Peat and organic alluvium** – waterlogged dark reddish brown to black peat deposits containing frequent fibrous and woody plant material, occasionally with a silt and clay component. Holocene deposits formed in freshwater alder carr, fen and reedswamp environments. Radiocarbon dates from Trench 3 (Section 300/301) at the terrace edge suggest at this location peat began to form in the late Neolithic at c -0.8m OD, however deeply buried peat bifurcating at lower elevations is likely to be of earlier date, both Neolithic and Mesolithic
- VII. Sand/silt (organic detrital)** – dark grey and blueish grey soft silty sand deposits with frequent humic and organic material, including fibrous and woody plant material. Occasional stone inclusions and organic content decreases with depth. Surface of deposit is heavily bioturbated where seen
- VIII. Sand (fluvial)** – coarse to fine-grained silty sands and sandy clays that are greenish to blueish grey and whiteish yellow in colour. Variable clast content with abundant gravel pebbles in places but largely stone free. Well to poorly sorted and unstratified. Possible Pleistocene sands forming the upper part of the Pleistocene gravel (fining up sequence and/or sheetwash at the terrace edge) or Holocene sand bars/channel deposits
- IX. Sand and gravel (fluvial)** – Buried terrace gravel, poorly sorted medium to fine sandy gravels. Abundant subangular, subrounded and rounded pebbles (<40mm) with patches of iron staining. Occasional organic inclusions are present but a likely result of rooting. Possibly reworked at terrace edge

C.5.22 Chalk bedrock was too deeply buried and not encountered during the evaluation

#### ***Transect 1 – Trenches 27, 23, 21, 18, 15, 14, 9, 3, 7 and 5***

C.5.23 Transect 1 (Figures 9 and 10) is located to the north of LP12 and runs parallel to the north-western boundary of site, oriented south-west to north-east towards the northern margins of the floodplain. Ground elevations are relatively flat throughout, undulating slightly from 1.43m OD (Trench 18) to 1.25m OD (Trench 21).

C.5.24 Sand and gravel deposits (terrace gravel) were identified at -0.43m OD (1.78m BGL) in Trench 9 (Transect 1, Section 901; Plate 7) and comprised poorly sorted sandy gravels containing abundant subangular, subrounded and rounded pebbles (<40mm). These deposits were >1.22m thick (not bottomed) and are likely to form the remnants of a Pleistocene gravel terrace or promontory extending southwards into the floodplain. Gradients in the surface of the gravel sharply decrease by 1m or more to the south-west and north-east in Trench 14 and Trench 3. Gravel deposits were also present in Trench 5, further to the north-east, at -3.75m OD (5.15m BGL) showing the continued downward gradient of the terrace gravel deposits.

C.5.25 The gravel deposits are overlain by coarse to fine-grained silty sands of probable fluvial origin, the surface of which was recorded through augering between -1.01m OD (2.33m BGL) in Trench 3 and -3.5m OD (4.9m BGL) in Trench 5. These deposits follow the sharp gradients seen in the underlying terrace gravels and slope downwards to the south-west and north-east and range between 0.2m thick (Trench 14) to >0.31m thick (Trench 7). They vary in content, from poorly to well sorted material and from stone free deposits to deposits containing frequent subangular, subrounded and rounded pebbles (<40mm).

- C.5.26 In Trench 3 the sand is overlain by 0.2m of detrital humic fine sandy silt, the surface of which was recorded at -0.78m OD in Section 300/301 (Fig. 8, layer 307). This deposit was dark greyish brown containing frequent organic detritus. The contact with the overlying peat was irregular and diffuse, showing clear evidence of bioturbation and rooting.
- C.5.27 Waterlogged dark reddish brown, oxidising to black wood peat overlies the sands and silt in Trenches 3, 5, 7 and 14, and is also present in Trench 18 at depth. The upper part of the peat in Trench 3 was investigated thoroughly due to the presence of horizontally aligned waterlogged wood – alder, ash and oak logs, roundwood and bark fragments, although no clear signs of wood working were found (see Goodburn, Appendix C.3). The wood is thought likely to represent natural tree splitting after high winds (Plate 3).
- C.5.28 Elevations in the surface of the peat vary from -0.46m OD (1.78m BGL) in Trench 3, to -2.47m OD (3.9m BGL) in Trench 18 and -1.6m OD in Trench 5 (3.00m BGL), again decreasing in elevation to the south-west and north-east away from the gravel terrace / promontory. Thicknesses of the wood peat deposits increase to the south-west and north-east, from 0.32m in Trench 3 to 1.9m thick in Trench 5 and >0.6m thick in Trench 18.
- C.5.29 Three horizons associated with peat (context 305) in Trench 3 were radiocarbon dated. The lower interface with the underlying silt (context 307) was dated to 2890-2670 cal BC, and a further sample from c 0.1m above that was dated to 2580-2460 cal BC (dates quoted are the combined humic/humin fractions at 95.4%; see Nicholson, Appendix C4). A date on alder roundwood towards the top of the peat was dated to 2030-1780 cal BC (Plates 8 and 9). This indicated the peat in Trench 3 began to form from the late Neolithic period. It is however likely peats recorded at lower elevations are of older date.
- C.5.30 No archaeological remains were recovered from within the peat apart from two pieces of undiagnostic flint debitage and a small spall of burnt flint in Trench 3. Bulk samples were largely unproductive with flots mainly consisting of root and stem fragments with woody fragments, a few seeds (*Carex* sp., *Lemna* sp., *Urtica dioica*, *Rubus* sp and *Stellaria media*), fragmented insect remains and rare <2mm charcoal (Appendix C.1).
- C.5.31 Overlying the peat deposits is a thick sequence of Holocene alluvium dating from the later prehistoric and probably historic periods. The lower alluvial layers were gleyed and contained frequent detrital material.
- C.5.32 These deposits increase in thickness further into the floodplain, from 0.28m in Trench 3 (Plate 8) to >1.5m in Trench 27, and comprise blueish grey silty clays. A sequence of oxidised alluvial clays overlie the gleyed detrital alluvium, and are intercalated with stabilisation/buried soils in places (Trenches 5, 21 and 23). These horizons occur between 0.57m OD (0.83m BGL, Trench 5) and 0.38m OD (0.87m BGL, Trench 21) and range between 0.09m (Trench 21) and 0.16m (Trench 5) thick. The oxidised alluvial deposits extend to beneath the modern ploughsoils and were recorded up to 1.64m in thickness (Trench 18). Archaeological boundary or drainage ditches such as those seen in Trench 7 occur within this unit, and within 1m of the current ground surface.

***Transects 2, 3 and 4 – Trenches 9, 6, 10 and 12; Trenches 9 and 13; and Trenches 9, 14 and 16***

- C.5.33 Transects 2, 3 and 4 (Figures 9 and 11-13) have been generated to further examine the gradients of the underlying Pleistocene gravel promontory deposits identified in Trench 9 as they extend into the floodplain. Transect 2 runs south-east, Transect 3 to the south, and Transect 4 to the south-west. These deposits were mainly recorded through hand-augering the base of the trenches.
- C.5.34 The surface of the terrace gravel initially rises southwards, from -0.43m OD in Section 901 to 0.06m OD in Section 900, with the surface observed to undulate within Trench 9. Section 900 is the highest point the gravel deposits were recorded (1.32m BGL), before sloping sharply down immediately to the south, south-east and south-west. From 0.06m OD the gravel surface decreases to -0.85m OD to the south-east (Transect 2, Trench 6), -2.09m OD to the south (Transect 3, Trench 13) and -1.51m OD to the south-west (Transect 4, Trench 14). The gravel surface continues to decrease, reaching depths of -1.31m OD in the south-east (Transect 2, Trench 12) and absent entirely from Trench 16 in Transect 4, which was augered to -4.12m OD (5.39m BGL).
- C.5.35 In Transects 2 and 4 the terrace gravels are overlain by fluvial sand deposits. The surface decreases to the south-east from -0.31m OD in Trench 6 to -1.36m OD in Trench 12 and was observed at -1.29m OD in Trench 14, to the south-west. The deposits are between 0.54m and 0.2m thick and consist of coarse to fine-grained sands with variable clast content. They are overlain by silty sand deposits, observed in Trenches 10 and 12 (Transect 2), that contain frequent detrital organic material and subrounded pebbles (<40mm).
- C.5.36 As in Transect 1, dark reddish brown peat deposits overlie the fluvial sands and silts to the south, south-east and south-west of the remnant gravel terrace / promontory. This wood peat follows the slopes of the gravel terrace, from -0.25m OD in Trench 6 to -0.49m OD in Trench 10 in the south-east (Plate 10) and is present at depths of -0.67m OD and -1.19m OD to the south-west (Trench 14) and south (Trench 13) respectively. These deposits increase in thickness downslope from 0.06m in Trench 6 to 0.8m thick in Trench 12 and 0.9m thick in Trench 13. The peat surface in Trench 12 is higher (-0.31m OD) than in Trench 10, but this may simply be reflecting erosion of the surface of the peat.
- C.5.37 Detrital alluvium overlies the wood peat deposits in all three transects. The surface of this occurs between -0.06m OD (Trench 12) and -0.17m OD (Trench 10) in Transect 2, -0.41m OD (Trench 13) in Transect 3 and -0.29m OD (Trench 14) in Transect 4. These deposits are gleyed, contain frequent detrital organic material and increase in thickness further into the floodplain away from the remnant gravel terrace / promontory. Thicknesses range from 0.11m in Trench 6 to >0.9m in Trench 16. These are overlain by a sequence of oxidised alluvial deposits that are intercalated with stabilisation/buried soil horizons in places. These horizons occur in Trenches 6, 10, 12 and 16 with elevations decreasing slightly southwards into the floodplain, from 0.79m OD in Trench 10 to 0.59m OD in Trench 16. These horizons are relatively thin, between 0.04m (Trench 10) and 0.19m (Trenches 6 and 16), generally stone-free with frequent organic material. The oxidised alluvial deposits occur beneath the ploughsoil, increasing in thickness into the floodplain, from 1.22m thick in Trench 6

to 4.3m thick in Trench 16. They are generally stoneless and homogenous silty clay deposits with rare organic inclusions.

***Transect 5 – Trenches 14, 16, 19, 50, 54, 58, 63, 67, 68, 71 and 72***

- C.5.38 Transect 5 (Figures 9 and 14) is located towards the centre of site, oriented north to south from the terrace edge, extending into the floodplain. Ground elevations undulate slightly but are relatively flat throughout, ranging between 1.16m OD (Trench 67) and 1.44m OD (Trench 63).
- C.5.39 Pleistocene terrace gravel deposits are present on the floodplain margins in Trench 14. The gravel surface is observed at -1.08m OD in Section 1400 and falls sharply to -1.51m OD to the south of the trench in Section 1401. These deposits are overlain by fine-grained fluvial sands that also shelf off abruptly southwards, from -0.52m OD to -1.31m OD, decreasing in thickness from 0.56m to 0.2m. A waterlogged dark reddish brown, wood peat overlies the fluvial sands in Section 1401, occurring at -0.67m OD. This 0.64m thick deposit contained a large amount of fibrous and woody plant material, including twigs and bark.
- C.5.40 A sequence of Holocene alluvium overlies the wood peat deposits and dominates the sedimentary sequence further out into the floodplain. The sequence was augered to a depth of -5.55m OD (6.75m BGL) in Trench 72. The lowest alluvial deposits here were laminated with alternating bands of sand and silt, possible indicating the proximity of a (tidal?) channel or creek. Deposits occurring between -0.15m OD and -1.58m OD contained frequent detrital organic material, although detrital alluvium was also present at -3.31m OD (Trench 16). Laminated deposits were also present in Trench 50 (Plate 11) and Trench 63 between 0.06m OD and -0.29m OD, overlying the detrital deposits. These lower deposits of alluvium comprise soft, stoneless, gleyed silty clays that are light blueish grey in colour. Oxidised alluvial deposits comprises the upper parts of the alluvium and is intercalated with stabilisation/buried soil horizons throughout most of the floodplain. The surface of the buried soils gently undulates, occurring between 0.59m OD (Trench 16) and 0.34m OD (Trench 67, Plate 12). These deposits are organic-rich and humic in places, but more ephemeral in others, ranging in thickness between 0.09m and 0.2m.
- C.5.41 Monolith and OSL samples were taken across the horizon in Trench 67 (context 6704) and a radiocarbon date on charcoal provided a TPQ of 780-480 cal BC (see Nicholson, Appendix C.4), that is early Iron Age. A bulk sample from this deposit produced a rooty flot with very little charred material other than occasional charcoal (>2mm). Waterlogged seeds included occasional *Chenopodium* sp. and abundant *Juncus* sp (see Cook, Appendix C.1).

***Transect 6 – Trenches 5, 97, 98, 99, 101, 100, 102, 104, 85 and 92***

- C.5.42 Transect 6 is situated to the east of the site, running north-west to south-east parallel to the eastern site boundary (Figures 9 and 15). It was positioned to identify any possible palaeochannel deposits originating from a south-west flowing watercourse located to the east of site and investigate the terrace/floodplain edge in the east. Ground elevations undulate slightly but remain relatively flat, ranging between 1.51m OD (Trench 92) and 1.23m OD (Trench 101).

- C.5.43 Pleistocene gravel deposits were present at -3.75m OD in Trench 5 (c 5.1m BGL) and are overlain by fine-grained sand deposits, identified at -3.5m OD in Trench 5 and -2.84m OD in Trench 97. These comprised stoneless greenish grey medium to fine silty and clayey sands. Deposits are thicker in Trench 97 (0.8m) than Trench 5 (0.25m) with the surface of the fluvial sands in Trench 97 occurring at a higher elevation. A detrital silt overlies these fluvial sands in Trench 97, occurring at -2.42m OD. This 0.42m thick deposit consists of soft, dark brown silt containing waterlogged woody and fibrous plant remains.
- C.5.44 Waterlogged, dark reddish brown wood peat deposits were present in Trenches 5, 97, 98 and 101, overlying the silt and fluvial sand. The wood peat surface occurs at -1.6m OD in Trench 5, rising slightly to -1.37m OD before falling a little to -1.56m OD in Trench 98 and then sharply to -2.82m OD in Trench 101. These peat deposits are of substantial thicknesses, reaching 1.9m in Trench 5 and >1.15m in Trench 101.
- C.5.45 The peat deposits are overlain by a thick sequence of Holocene alluvium. Possible laminated deposits were observed at -0.88m OD in a test pit excavated in Trench 85 and consisted of stoneless, gleyed, blueish grey clay with very fine sandy laminations. This is overlain by thick detrital alluvial deposits that are 2.33m thick in Trench 101 and were not bottomed in Trenches 92, 100, 102, and 104. The surface of these deposits undulates throughout the floodplain, occurring between -0.01m OD (Trench 92) and -0.4m OD (Trench 5). The deposits comprise soft, light blueish grey, gleyed, silty clays containing frequent detrital organic material. Oxidised alluvial deposits overlie the lower gleyed alluvium and are intercalated with buried soils throughout. The surface of the buried soils undulates over the transect, ranging from 0.69m OD (Trench 99) to 1.00m OD (Trench 104) and they vary in thickness between 0.3m (Trench 102) and 0.1m (Trench 98) thick. They consist of dark greyish brown to dark grey silty clays or clayey silts with varying quantities of organic and humic material that are often poorly sorted and bioturbated. An accumulation of flint cobbles possibly indicating a surface was recorded at c 1m BGL beneath the stabilisation horizon/buried soil in Trench 101 (Fig. 5; Plate 13).

## Discussion and conclusions

- C.5.46 Geoarchaeological investigations undertaken throughout the northern end of Land Parcel 12 have served well in broadly characterising the nature of the sub-surface sedimentary sequences underlying the site. Based upon the evidence from the series of composite transects (Transects 1-6, Figures 9-15), the following observations can be made.
- C.5.47 Deep deposits of Holocene minerogenic alluvium (freshwater and brackish) with multiple intercalated peat horizons blanket the majority of Land Parcel 12 and seal Pleistocene fluvial gravel at depth. The sedimentary sequence invariably becomes thicker further out into the floodplain, with up to 19m of alluvium recorded in GI borehole data adjacent to the Thames. Adjacent to the terrace edge, however, a gravel promontory lies at relatively shallow depth (as little as c 1.3m BGL in Trench 9, at c 0m OD), and is sealed beneath alluvium and fringed with peat, forming a small, elongated shelf or step-like feature protruding a short way into the floodplain. The shape and extent of this promontory was mapped through hand-augering below the base of the trenches, and may be a remnant of the middle Devensian East Tilbury Marshes Gravel (Kempton Park). The more deeply buried gravel deposits adjacent

to the Thames probably belong to the younger late Devensian Shepperton Gravel (Stafford *et al.* 2012, fig.8.3).

- C.5.48 On a broad level, the sediment sequences on Land Parcel 12 can generally be considered typical for the area where Holocene accumulation is dominated by changes occurring within the estuary as a consequence of fluctuations in the rate of sea-level rise during the Holocene, as well as tectonic subsidence in the south-east region of England following the retreat of the northern glaciers at the end of the last glacial period, c 12, 000 BP (See background section above). At a local level, however, variation on what is considered a typical sequence should be expected, depending on the form of the underlying relict topography left by cold-climate braided stream systems. ie the early Holocene topographic template. Locally, sequence accumulation may be influenced at the floodplain margins by proximity to the higher ground of the gravel terraces. Here, the topographic template typically lies at higher elevations, and sequences may receive sediment runoff from the slopes as well as freshwater alluvial inputs and fluvial incision emanating from watercourses draining into the floodplain. Sequences associated with buried gravel promontories, or gravel highs within the floodplain forming islands surrounded wetland environments, may also show variation. Such locations formed important ecotonal zones (wetland/dryland interface), attractive to local communities in which to exploit a range of wetland resources (Stafford *et al.* 2012, Figs 8.4 and 8.6).
- C.5.49 The elevation and gradients of the underlying gravel surface associated with both the terrace edge, promontories and islands are important to estimate. High elevations shelving off with steep gradients over a short distance have the potential to develop static ecotonal zones that remain dry ground over a long period of time, immediately adjacent to the wetland edge. As such, these areas have the potential to preserve multiperiod activity up until the point it is overwhelmed by the expanding wetland front. Equally, local variation will also effect elevation and age of peat/organic facies. Peat associated with gravel highs may be shallower, conflated and well humified, but bifurcating into several horizons deeper into the floodplain. Broadly, peats tend to be diachronous across rising gradients associated with an expanding wetland front. Those peats lying at extreme depth further into the floodplain are likely to have accumulated during the earlier Holocene and are represented stratigraphically on higher areas by a conflated dryland buried soil that may also contain artefacts of later date (Stafford *et al.* 2012, 101 and fig 8.5).
- C.5.50 Provided sufficient subsurface data is available at depth, the archaeological and palaeo-environmental potential of these Lower Thames floodplain sites can be predicted, but much relies on being able to model the surface of the basal gravel. On the floodplain the great depth of the sequences means that initial investigation may be carried out using remote subsurface mapping techniques, ground-truthed with deep boreholes in order to target areas to focus investigations (Bates and Stafford 2013, fig. 60).
- C.5.51 In Land Parcel 12, conventional deep trenching was only able to examine the upper 2m of this sequence except in a few locations, although hand-augering was able to record sediments up to 6.75m BGL at the southern limit of the evaluated part of this land parcel. Although there may be some potential within the estuarine minerogenic alluvium for activity such as saltmaking to be preserved adjacent to relict creeks, this was not evident in the trial trenches, and instead much of the geoarchaeological work

focussed on the terrace edge where the underlying gravel surface could be investigated and mapped. The surface of this gravel is undulating, which is not uncommon given that the majority of the terrace gravels associated with the Thames system were laid down in cold-climate braided stream systems comprising multiple shallow fast-flowing channels interspersed with sand bars. It is therefore also common for the surface of these deposits to be capped locally by thin sandy facies, and streams flowing laterally along the base of the terrace fed by surface run-off and subsurface drainage from the higher terraces are also frequent.

- C.5.52 The basal gravels in Trench 9 slope sharply down to the south-east, south and south-west, as highlighted by Transects 1 - 4, indicating that these deposits comprise the southern limit of the observed promontory which forms a relatively thin ridge projecting southwards into floodplain. From this information it is clear that this promontory with its sharp gradients would have represented a fairly static ecotonal zone prior to burial. Radiocarbon dates from Trench 3 indicate that during the late Neolithic period this promontory was fringed by encroaching wetland environments in which peat formation occurred. Unfortunately, the gravel surface was only rarely seen in the 2m deep trenches, lying just below the base of the 2m deep trench excavations, and the scope of the deeper test-pitting intended to check for the presence/absence of archaeological remains was reduced, so that this aim was not realised.
- C.5.53 Waterlogged semi-terrestrial wood peat and detrital silts overlying the fluvial sands and gravels at the terrace edge formed through the expansion of wetland environments, at these elevations probably during the mid-Holocene. This has been demonstrated through a series of radiocarbon dates from Trench 3 where the base of organic sediments lies at c -0.8m to -1m OD at 2890-2670 cal BC. Comparing this elevation and date with regional models for wetland expansion formed on uncompressible sediments, this is broadly consistent with other sites (Bates and Stafford 2013, fig 96). Should archaeological remains be preserved on the underlying dryland interface at this specific location it will be restricted to that pre-dating the late Neolithic, becoming potentially stratified at different levels following the downslope gradient, the base of the diachronous peat becoming progressively older. For example, using the regional model, the key interface in Trench 13 at c -2m OD could potentially be of early Neolithic date at c 3500 BC (ibid.).
- C.5.54 The peat deposits that were sampled in Trench 3 were very woody and sulphurous smelling, although the bulk samples produced limited seed assemblages. This may be a result of humification, and there may be other organic facies buried in this land parcel with greater potential that were not exposed for sampling during this evaluation. There is a long history of pollen investigation associated with the floodplain sequences in this region and there is no reason to doubt that pollen will be sufficiently preserved in the organic sequences to carry out analysis, when coupled with a robust radiocarbon dating programme for vegetation reconstruction. However, from an archaeological perspective, the value of such work is greatly enhanced where directly associated with stratified archaeological remains, particularly when combined with other proxies such as plant remains and insects, and no good evidence of such remains was recovered in this evaluation.
- C.5.55 Equally, given the nature of the minerogenic alluvial (estuarine) deposits, it is most likely that microfossils such as foraminifera and diatoms will be preserved (although



ostracods preservation can be patchier), and when combined they can provide data related to palaeohydrology and cycles of marine inundation. Minerogenic sequences are difficult to date without interleaved organic layers and/or archaeological features, but some chronological framework can be achieved through OSL sampling providing that a series of samples are taken rather than single dates. On Land Parcel 12, charcoal from a stabilisation horizon within the upper oxidised alluvium produced a radiocarbon date in the early Iron Age, although this can only be considered a TPQ (*terminus post quem*) and deposition could have been later. At similar levels and stratigraphic position elsewhere medieval to post-medieval drainage and field boundary ditches occurred, which based on evidence of marsh reclamation along the Lower Thames may be more appropriate. This stabilisation horizon occurred in multiple trenches at similar levels of c 0.5m OD and was clearly a site-wide phenomenon extending across the floodplain area. OSL samples were recovered from Trench 67 should clarification be required.

- C.5.56 As with the peat sequences, the value of further work on the alluvium is greatly enhanced if directly associated with archaeological remains, but there is also a wider group value of such work, adding to the corpus of regional data for the Lower Thames in terms of Quaternary studies, as well as enhancing current predictive models and investigating spatial diversity of floodplain environments through time, the latter also having been a focus of study at the London Gateway site at Shellhaven (Bates *et al.* 2012).

## Appendix D      References

---

- ACBMG, 2007 *Ceramic building material, minimum standards for recovery, curation, analysis and publication*
- Ballin, T B, 2021 *Classification of Lithic Artefacts from the British Late Glacial and Holocene Periods*. Oxford, Archaeopress.
- Bamford, H M, 1985 *Briar Hill. Excavation 1974–1978*, Northampton Development Corporation Archaeological Monograph **3**. Northampton: Northampton Development Corporation
- Bannister, J, 1961 Barrow at East Tilbury, Essex. *Thurrock Historical Society Journal* **6**, 19–27
- Batchelor, C R, Branch, N P, Allison, E, Austin, P A, Bishop, B, Brown, A, Elias, S E, Green, C P and Young D S, 2014 The timing and causes of the Neolithic elm decline: New evidence from the Lower Thames Valley (London, UK), *Environmental Archaeology* **19(3)**, 263-290
- Batchelor, C R and Young, D S, 2017 Tilbury 2, the Former RWE Power Station, Tilbury, South Essex: Geoarchaeological fieldwork, radiocarbon dating and updated deposit model report, Quaternary Scientific (QUEST) Unpublished Report October 2017; Project Number140/16
- Bates, M R, 1999 A geoarchaeological evaluation of the Thames/Medway alluvial corridor of the Channel Tunnel Rail Link, CTRL Union Railways Ltd, unpublished client report
- Bates, M R and Barham A J, 1995 Holocene alluvial stratigraphic architecture and archaeology of the Lower Thames area, in Bridgland *et al.* 1995, 35-49
- Bates, M R, Bates, C R, Cameron, N, Huckerby, E, Nicholson, R and Whittaker, J E, 2012 A multi-disciplinary investigation of the sediments at the London Gateway site, Essex: Geophysics, palaeoenvironment and dating. Final deposit model update, unpublished report by Oxford Archaeology for DP World
- Bates, M R and Stafford, E C, 2013 *The Thames Holocene: a geoarchaeological approach to the investigation of the river floodplain for High Speed 1*, Oxford Wessex Archaeol, Oxford and Salisbury
- Bates, M R and Whittaker, K, 2004 Landscape evolution in the Lower Thames valley: implications for the archaeology of the earlier Holocene period, in Cotton, J and Field, D, *Towards a new Stone Age: aspects of the Neolithic in south-east England*, CBA Research Report **137**, York
- BGS, 2020 *Geology of Britain Viewer*. Retrieved from <http://mapapps.bgs.ac.uk/geologyofbritain/home.html>

- Biddulph, E, Foreman, S, Stafford, E, Stansbie, D and Nicholson, R, 2012 *London Gateway: Iron Age and Roman Salt Making in the Thames Estuary, Excavation at Stanford Wharf Nature Reserve, Essex*, Oxford Archaeology Monograph **31**
- Bridgland, D R, Allen, P, and Haggart, B A, 1995 *The Quaternary of the lower reaches of the Thames: field guide*, Quaternary Research Association, Durham
- Bronk Ramsey, C, 2009 Bayesian analysis of radiocarbon dates, *Radiocarbon* **51(1)**, 337–360
- Brown, M and Pattison, P, 2003 *Coalhouse Point: Archaeological features in the inter-tidal zone, east Tilbury, Essex*, English Heritage
- Butler, C, 2005 *Prehistoric Flintwork*. Tempus, Stroud
- Cappers, R T J, Bekker R M and Jans, J E A, 2012 *Digital Seed Atlas of the Netherlands*. Groningen Archaeological Studies **4**, 2nd Edition, Barkhuis Publishing, Eelde, The Netherlands
- Champness, C, 2006 Lion Business Park, near Gravesend, Kent, Interim Geoarchaeological Assessment Report, Oxford Archaeology
- Champness, C, 2007 Lion Business Park, near Gravesend, Kent, Archaeological Evaluation Report, Oxford Archaeology
- Chartered Institute for Archaeologists (CIfA), 2014a *Standard and Guidance for Archaeological Evaluation*. Retrieved from <http://archaeologists.net/sites/default/files/node-files/lfASG-Evaluation.pdf>
- Chartered Institute for Archaeologists (CIFA), 2014b *Standard and Guidance for the Creation, Compilation, Transfer and Deposition of Archaeological Archives*
- Darby, H C, 1971 *The Domesday Geography of Eastern England*, reprinted 1971.
- Devoy, R J N, 1977 Flandrian sea-level changes in the Thames Estuary and the implications for land subsidence in England and Wales, *Nature* **220**, 712-715
- Devoy, R J N, 1979 Flandrian sea level changes and vegetation history of the lower Thames Estuary, *Philosophical Transactions of the Royal Society of London* **B285**, 355-407
- Devoy, R J N, 1980 Post-glacial environmental change and man in the Thames estuary; a synopsis, in *Archaeology and coastal change, Society of Antiquaries occasional paper*, new series **1**, London
- Devoy, R J N, 1982 *Analysis of the geological evidence for Holocene sea-level movements in south-east England*, Proceedings of the Geologists' Association **93**, 65–90
- Drury, P J and Rodwell, W J, 1973 Excavations at Gun Hill, West Tilbury. *Trans Essex Archaeol Soc* **5**, 48-112

- Evans, C, Appleby, G, and Lucy, S, 2016 *Lines in the Land: Mucking Excavations by Margaret and Tom Jones, 1965-1978. Prehistory: context and summary*. Cambridge Archaeological Unit Archives Series: Historiography and Fieldwork **2/Mucking 6**
- Gibbard, P L, 1999 Thames Valley, in *A revised correlation of the Quaternary deposits in the British Isles* (ed. D Q Bowen), Geological Society Special Report **23**, 58
- Haggart B A, 1995 A re-examination of some data relating to Holocene sea-level changes in the Thames Estuary, in Bridgland *et al.* 1995, 329-338
- Highways England, 2018 *Lower Thames Crossing: A Scheme Wide Specification for Archaeological Trial Trenching: unpublished document HE540039-CJV-GEN-GEN-SPE-HER-00001draft, Revision 1.05*
- Historic England, 2011 *Environmental Archaeology. A guide to the theory and practice of methods, from sampling and recovery to post-excavation* (2nd edition). Centre for Archaeology guidelines
- Historic England, 2015a *Management of Research Projects in the Historic Environment: The MoRPHE Project Managers' Guide*, Swindon: Centre for Archaeology Guidelines
- Historic England, 2015b *Geoarchaeology: Using an earth sciences approach to understand the archaeological record*
- Jones, A P, Tucker, M E, and Hart, J K, 1999 Guidelines and Recommendations, in *The description and analysis of Quaternary stratigraphic field sections*, Technical Guide No. **7**. (eds A P Jones, M E Tucker and J K Hart), Quaternary Research Association: London, 27-76
- Long, A J, Scaife, R G and Edwards, R J, 2000 Stratigraphic architecture, relative sea-level, and models of estuary development in southern England: new data from Southampton Water, in *Coastal and estuarine environments: sedimentology, geomorphology and geoarchaeology* (eds K Pye and J R L Allen), Geological Society Special Publication **175**, London, 253-279
- Medlycott, M ed., 2011 Research and Archaeology Revisited: A Revised Framework for the East of England, *East Anglian Archaeology Occasional Paper 24*, Association of Local Government Archaeological Officers
- MoLA, 2014 London medieval and post-medieval ceramic building material codes, Museum of London Archaeology, <https://www.mola.org.uk/medieval-and-post-medieval-ceramic-building-materials-fabric-dating-codes> (Accessed Nov 2021)
- Oxford Archaeology(OA), 2005 East Tilbury and Linford, Essex, Archaeological Evaluation Report, unpublished report
- Oxford Archaeology (OA), 2016 Neolithic, Bronze Age and Modern Activity at Bata Fields, East Tilbury, Essex. Evaluation Report, unpublished report

- Oxford Archaeology (OA), 2020a Lower Thames Crossing Scheme-wide Written Scheme of Investigation for Trial Trenching south of the River Thames, version 2
- Oxford Archaeology (OA), 2020b Lower Thames Crossing Scheme-wide Written Scheme of Investigation for Trial Trenching north of the River Thames, version 2, unpublished report prepared by Oxford Archaeology for LTC on behalf of Balfour Beatty
- Oxford Archaeology (OA), 2021 Lower Thames Crossing Detailed Written Scheme of Investigation R for Trial Trenching of Land Parcels 12, 13, 20, 38, 129, 130 and 136, unpublished report prepared by Oxford Archaeology for LTC on behalf of Balfour Beatty
- Oxford Cotswold Archaeology (OCA), 2021 Lower Thames Crossing Archaeological Evaluation Report for Trial Trenching of Land Parcel 37, Land at East Tilbury, Essex, unpublished report prepared by Oxford Cotswold Archaeology for LTC, Document Number HE540039-BAL-GEN-GEN-REP-HER-00033, v1.1 January 2021
- Oxford Cotswold Archaeology (OCA), 2022 Lower Thames Crossing Archaeological Evaluation Report for Trial Trenching of Land Parcels 6-8, Land West of Linford, East Tilbury, Essex, unpublished report prepared by Oxford Cotswold Archaeology for LTC, Document Number HE540039-BAL-GEN-GEN-REP-HER-00042, v1.1 January 2022
- Palmer, J J, 2019 *Open Domesday*. <https://opendomesday.org/place/>: University of Hull
- Place Services, 2019 *Lower Thames Crossing Aerial Investigation and Mapping Report*, Essex County Council
- Priestly-Bell, G, 1999 An archaeological evaluation of the line of the Denton Relief Road, Gravesend, Kent, *Archaeology South-East (ASE)*
- Rackham, O, 1980 The medieval landscape of Essex in Buckley, D G (ed) *Archaeology in Essex to AD1500*, CBA Research Report **34**, 103-107
- Reimer, P, Austin, W, Bard, E, Bayliss, A, Blackwell, P, Bronk Ramsey, C, Butzin, M, Cheng, H, Edwards, R, Friedrich, M, Grootes, P, Guilderson, T, Hajdas, I, Heaton, T, Hogg, A, Hughen, K, Kromer, B, Manning, S, Muscheler, R, Palmer, J, Pearson, C, van der Plicht, J, Reimer, R, Richards, D, Scott, E, Southon, J, Turney, C, Wacker, L, Adolphi, F, Büntgen, U, Capano, M, Fahrni, S, Fogtmann-Schulz, A, Friedrich, R, Köhler, P, Kudsk, S, Miyake, F, Olsen, J, Reinig, F, Sakamoto, M, Sookdeo, A and Talamo, S, 2020 The IntCal20 Northern Hemisphere radiocarbon age calibration curve (0–55 cal kBP), *Radiocarbon*, **62**
- Schulting, R, 2013 'Tilbury Man': A Mesolithic Skeleton from the Lower Thames. *Proceedings of the Prehistoric Society* **79**, 19–37

- Schweingruber, F H, 1990 *Microscopic wood anatomy*. 3rd Edition. Birmensdorf: Swiss Federal Institute for Forest, Snow and Landscape Research
- Sheridan, J A, 2008 Towards a fuller, more nuanced narrative of Chalcolithic and Early Bronze Age Britain 2500–1500 BC . *Bronze Age Review* **1**, 57–78
- Sidell, J, Cotton J, Rayner, L and Wheeler, L, 2002 *The prehistory and topography of Southwark and Lambeth*, MoLAS Monograph **14**, London
- Sidell, J, Wilkinson, K N, Scaife, R G and Cameron, N, 2000 *The Holocene evolution of the London Thames: archaeological investigations (1991-1998) in advance of the London Underground Limited Jubilee Line Extension*, MoLAS Monograph **5**, London
- Sidell, J and Wilkinson, K, 2004 The Central London Thames: Neolithic river development and floodplain archaeology, in Cotton and Field 2004, 38-48
- Smoothy, M D, 1993 *Horndon-Coalhouse Fort (Tilbury) Gas pipeline, Archaeological report, Linfoord H-CHF93*
- Stace, C, 2010 *New Flora of the British Isles*, 3rd Edition, Cambridge, Cambridge University Press
- Stafford, E, with Goodburn, D and Bates, M, 2012 *Landscape and Prehistory of the East London Wetlands: Investigations along the A13 DBFO Roadscheme, Tower Hamlets, Newham and Barking and Dagenham, 2000-2003*, Oxford Archaeology Monograph **17**
- Stuiver, M, and Polach, H A, 1977 Reporting of <sup>14</sup>C data, *Radiocarbon* **19**, 355–363
- Von den Driesch, A, 1976 *A guide to the measurement of animal bone from archaeological sites*. Peabody Museum Bulletin 1. Harvard: Peabody Museum of Archaeology and Ethnology
- Weaver, S, 2003 Denton Relief Road, near Gravesend, Kent, Archaeological Investigation Report, Oxford Archaeology
- Wenban-Smith, F and Bates, M, 2020 Lower Thames Crossing, Palaeolithic and Quaternary Deposit Model (PQDM), and Preliminary Assessment of Archaeological Potential, Unpublished Client Report
- Young, D S, 2016 Dalefield Way, Gravesend, Kent: Geoarchaeological deposit model report. Quaternary Scientific (QUEST) Unpublished Report January 2016; Project Number 220/15

## Appendix E      Abbreviations and Glossary

---

**ADS** Archaeology Data Service. Digital archaeological archive

**CDM** Construction Design Manual. Health and safety guidance for the construction industry

**CPD** Continuing Professional Development

**ClfA** Chartered Institute for Archaeologists

**DBA** Desk Based Assessment. Detailed assessment of archaeology and other aspects of the historic environment

**DCO** Development Consent Order

**EIA** Environmental Impact Assessment. Detailed study of environmental impacts as directed under the The Town and Country Planning (Environmental Impact Assessment) Regulations 2017 following on from EU Directive EIA Directive (85/337/EEC)

**ES** Environmental Statement. The principal environmental report detailing environmental impacts within an EIA

**GPS** Global Positioning System

**HER** Historic Environment Record

**LTC** Lower Thames Crossing

**MCIfA** Member of the Chartered Institute for Archaeologists

**MoRPHE** Management of Research Projects in the Historic Environment

**NMP** National Mapping Programme. A study of aerial photographs and digitisation of resulting data into GIS. Originally funded by Historic England

**OASIS** Online Access to the Index of archaeological investigations.  
The OASIS project brings together a number of strategic partners: the Archaeology Data Service, Historic England, Historic Environment Scotland, and the Royal Commission on the Ancient and Historical Monuments of Wales under the umbrella of the University of York

**OCN** Old County Number. Historic England's reference for material that is not readily-available online and may represent historic archaeological work that consists of paper archives or has yet to be formally reported on

**PINS** Planning Inspectorate

**RAMS** Risk Assessment Method Statement

**SMC** Scheduled monument consent

**TDR** Trusted Digital Repository

**UKIC** United Kingdom Institute for Conservation

**WSI** Written Project of Investigation. A detailed method statement for archaeological work

**WSL** – Western Southern Link  
The Western Southern Link (WSL) is an alternative for Short List Routes 2, 3 and 4 to the south of the River Thames.

## Appendix F Site Summary

---

<b>Site name:</b>	Lower Thames Crossing, Land Parcel 12, Tilbury Marshes, Essex
<b>Site code:</b>	LTC12T21
<b>Grid Reference</b>	NGR 567179, 177141
<b>Type:</b>	Evaluation
<b>Date and duration:</b>	Between 1st September and 27th October 2021
<b>Area of Site</b>	16.53ha

### Location of archive:

The archive from LTC12T21 (Land Parcel 12) will form part of the overall trial trenching scheme archive. This will be deposited in a repository consistent with the standards required by the Museums and Galleries Commission following completion of the archaeological phase of this project. This may either be with the local receiving museum in Thurrock or, if no such repositories are available, with a repository for the whole project designated by LTC. LTC retain the overall responsibility for the successful deposition of the project archive.

Currently, the archive is held at Oxford Archaeology's head office, Janus House, Osney Mead, Oxford, Oxfordshire, OX2 0ES. Oxford Archaeology will store the archive for LTC for a maximum period of 2 years following the completion of the project. If the storage of the archive at OA's office extends past this period, an extension to the storage period and final deposition timetable will be reviewed by OA and LTC and agreed with the major stakeholders.

### Summary of Results:

Oxford Cotswold Archaeology was commissioned by Balfour Beatty to undertake a trial trench evaluation of Land Parcel 12 covered by WSI R of the Lower Thames Crossing Pre-Enabling Works. This land parcel is located between West Tilbury and East Tilbury within the county of Essex and Thurrock unitary authority (NGR 567179, 177141). A total of 98 trenches were excavated and recorded between 1st September and 27th October 2021.

As anticipate from existing borehole data, the trenches revealed that most of the site was covered in Holocene alluvium to a depth in excess of 2m. At the north-west edge of the site, however, Pleistocene gravels were exposed at the northern end of Trench 9, and were located by augering in several adjacent trenches, indicating that a gravel shelf existed at relatively shallow depth along this edge of the site. The remainder of the trenches were unable to expose the full sequence of Holocene deposits or establish clearly whether there was archaeological activity upon this shelf.

The earliest artefact from the site was a blade-like flake recovered from an alluvial deposit in Trench 18, not far beyond the edge of the gravel shelf. This piece was probably Mesolithic/early Neolithic in date but was likely to have been redeposited, despite being in good overall condition.

At just below 2m down, Trench 3 revealed a peat deposit with a layer of waterlogged wood remains. The main concentration of wood was close to the surface of the peat, and included substantial lengths of roundwood trunks that had split in half, and had subsequently been heavily eroded, presumably during exposure prior to burial by later alluvial deposits. Several of the surrounding trenches also revealed peat with waterlogged wood preservation, but none of the wood exhibited signs of working.



The wood was mostly aligned from SW to NE parallel to the edge of the gravel terrace, and is believed to have split naturally from a mixed carr-type woodland comprising conifers, ash, alder and oak. A series of samples submitted for radiocarbon dating indicated that this peat accumulated from the late Neolithic to the end of the early Bronze Age. This is consistent with peat formation elsewhere on the Lower Thames floodplain. Two pieces of struck flint and a burnt flint were also found in this layer, a hard-hammer struck flake being consistent with the date of the wood upon which it was found.

A later dark brownish grey clayey silt horizon was evident in a number of trenches across the site, and was interpreted as a buried soil horizon. A fragment of charcoal from this was radiocarbon-dated to 780-510 cal BC, showing that this deposit must have formed in or after the early Iron Age. Animal bone fragments were found on this horizon in a nearby trench. A patch of flint cobbles was associated with what is probably the same buried horizon, and may have been hardstanding or possibly related to a path.

The majority of the trenches revealed sterile alluvial deposits formed from successive phases of inundation. The only other features were several post-medieval ditches from two phases of drainage and land partition, the earlier probably 16th - 18th century, the later matching land boundaries on 19th century historic maps.



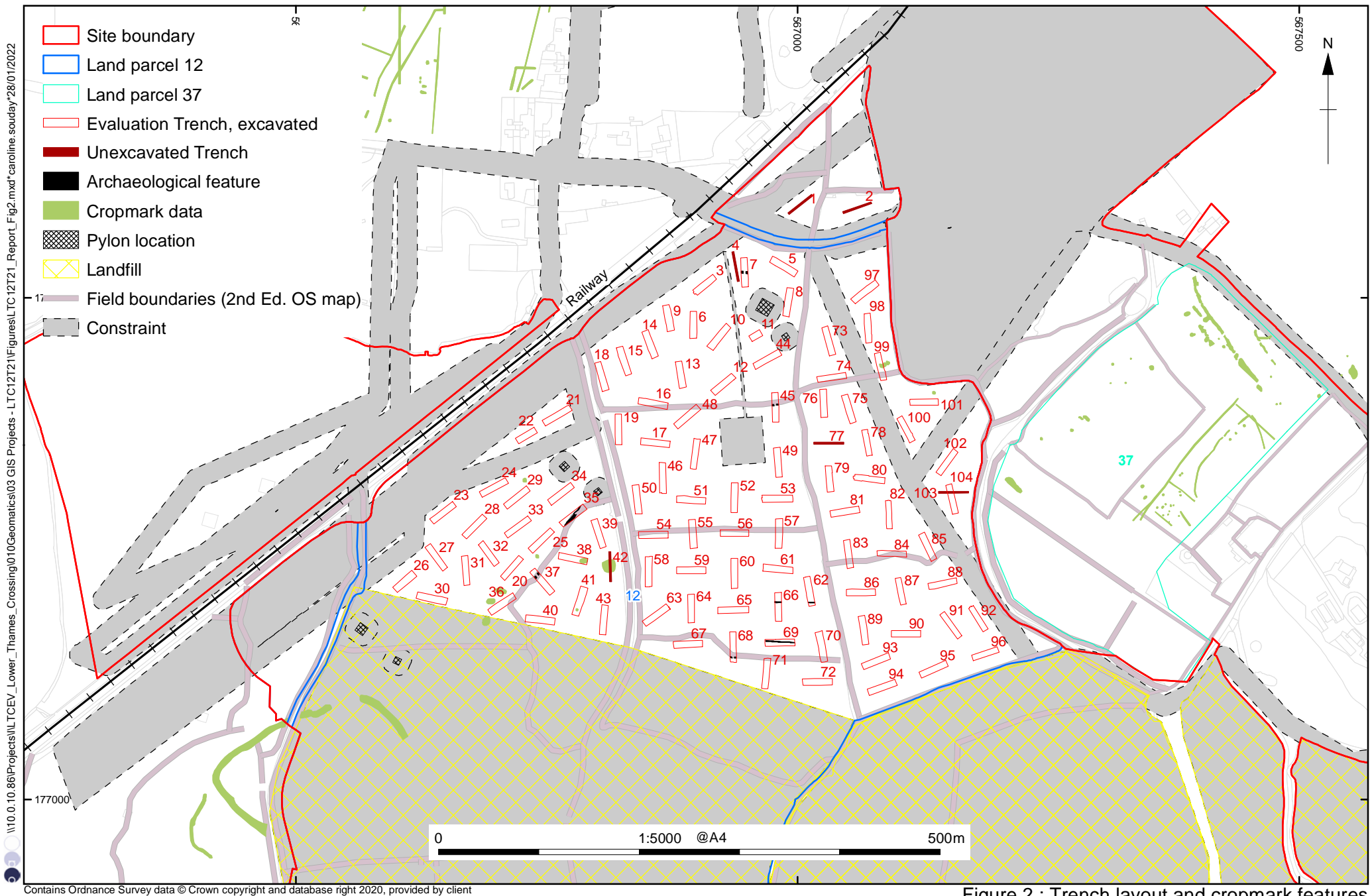

\\10.0.10.86\Projects\10\_Geomatics\03\_GIS Projects - LTC12T21\Figures\LTC12T21\_Report\_Fig2.mxd\caroline\_souday\*28/01/2022

Contains Ordnance Survey data © Crown copyright and database right 2020, provided by client

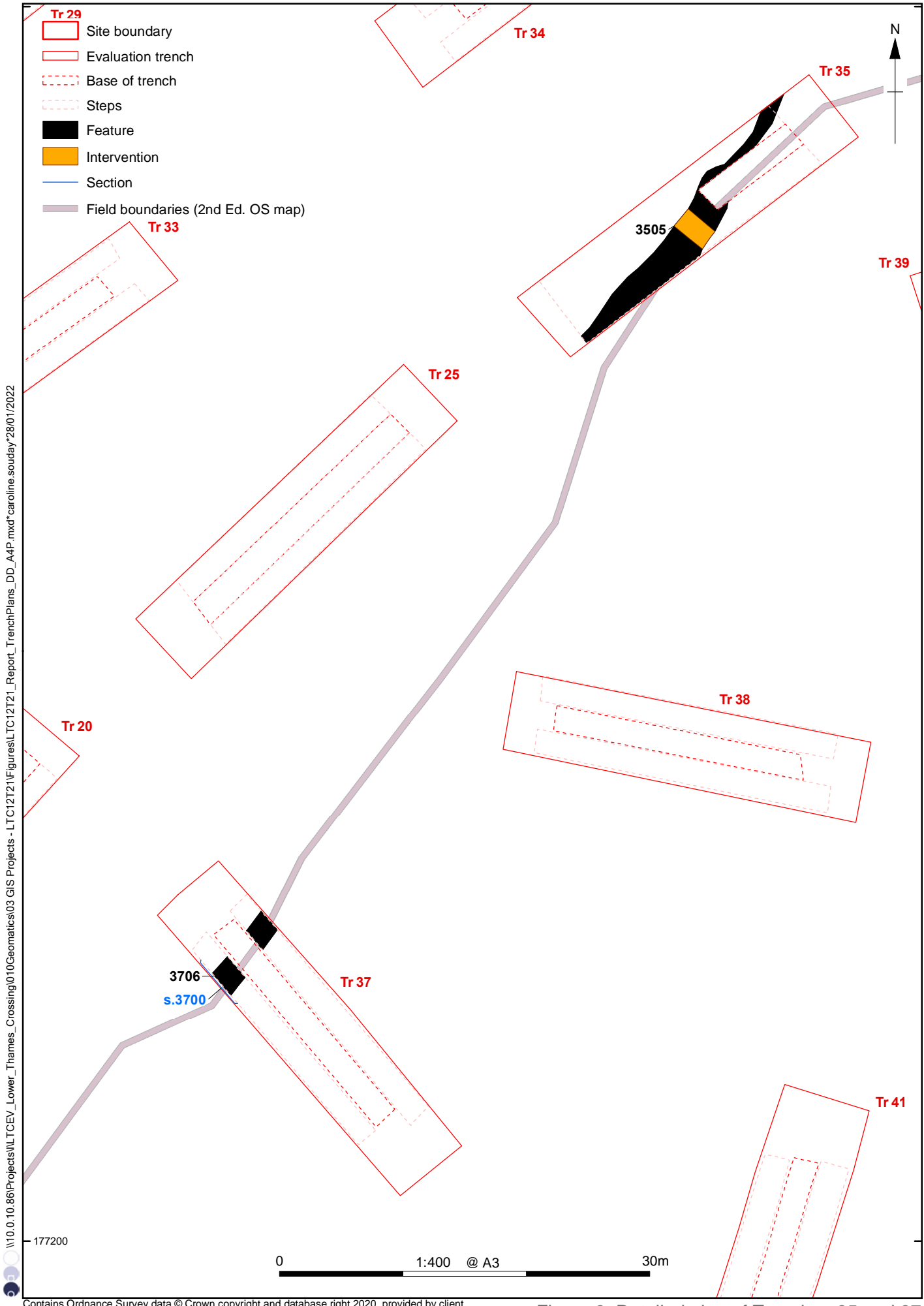

\\10.0.10.86\Projects\Lower\_Thames\_Crossing\010Geomatics\03 GIS Projects - LT C12T2 \Figures\TC12T21\_Report\_TrenchPlans\_DD\_A4P.mxd\*caroline.souday\*28/01/2022

Contains Ordnance Survey data © Crown copyright and database right 2020, provided by client

Figure 3: Detailed plan of Trenches 35 and 37

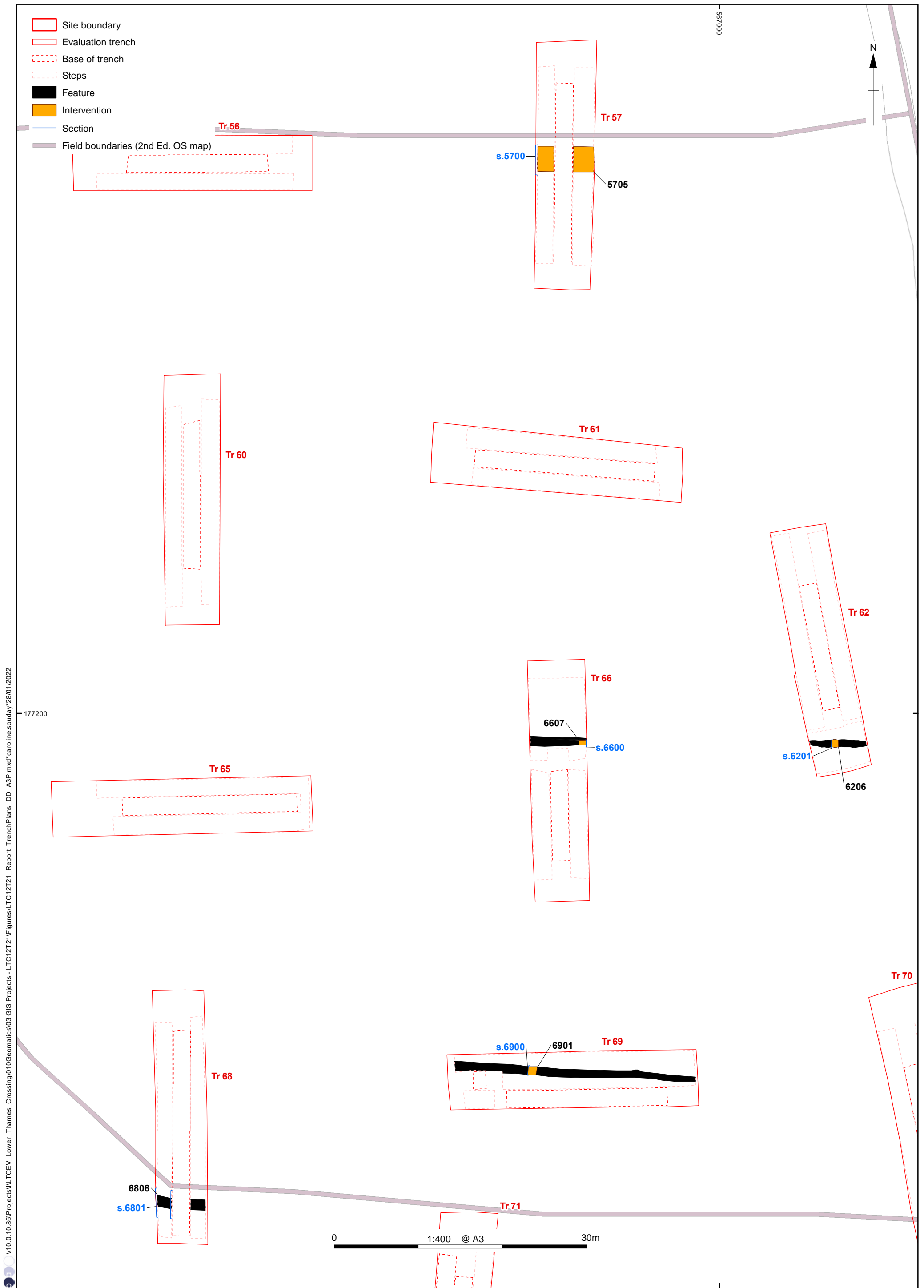

I:\10.0.10.86\Projects\TCEV\_Lower\_Thames\_Crossing\010\Geomatics\03 GIS Projects - LTC12T21\Figures\LTC12T21\_Report\_TrenchPlans\_DD\_A3P.mxd\*caroline.souday\*28/01/2022

Contains Ordnance Survey data © Crown copyright and database right 2020, provided by client

Figure 4: Detailed plan of Trenches 57, 62, 66, 68 and 69

\\10.0.10.86\Projects\ILTCEV\_Lower\_Thames\_Crossing\010Geomatics\03 GIS Projects - LTC12721\Figures\LTC12721\_Report\_TrenchPlans\_DD\_A3L.mxd\*caroline.souday\*28/01/2022

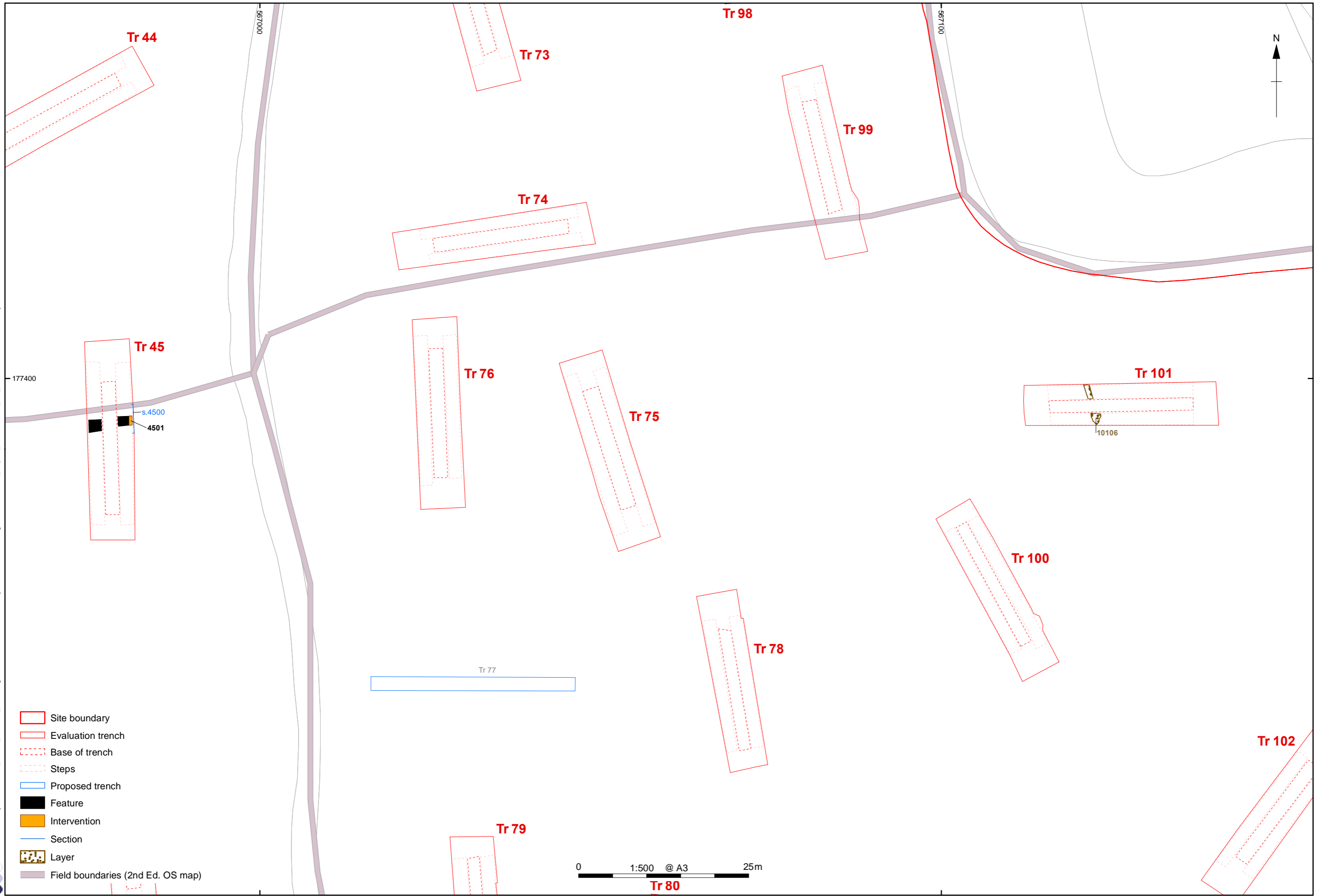

Contains Ordnance Survey data © Crown copyright and database right 2020, provided by client

Figure 5: Detailed plan of Trenches 45 and 101

\\10.0.10.86\Projects\Lower\_Thames\_Crossing\010\Geomatics\03 GIS Projects - LT12121\Figures\LT12121\_Report\_Fig6.mxd\*caroline.souday\*28/01/2022

### Detailed plan of waterlogged wood in Trench 3

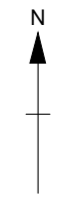
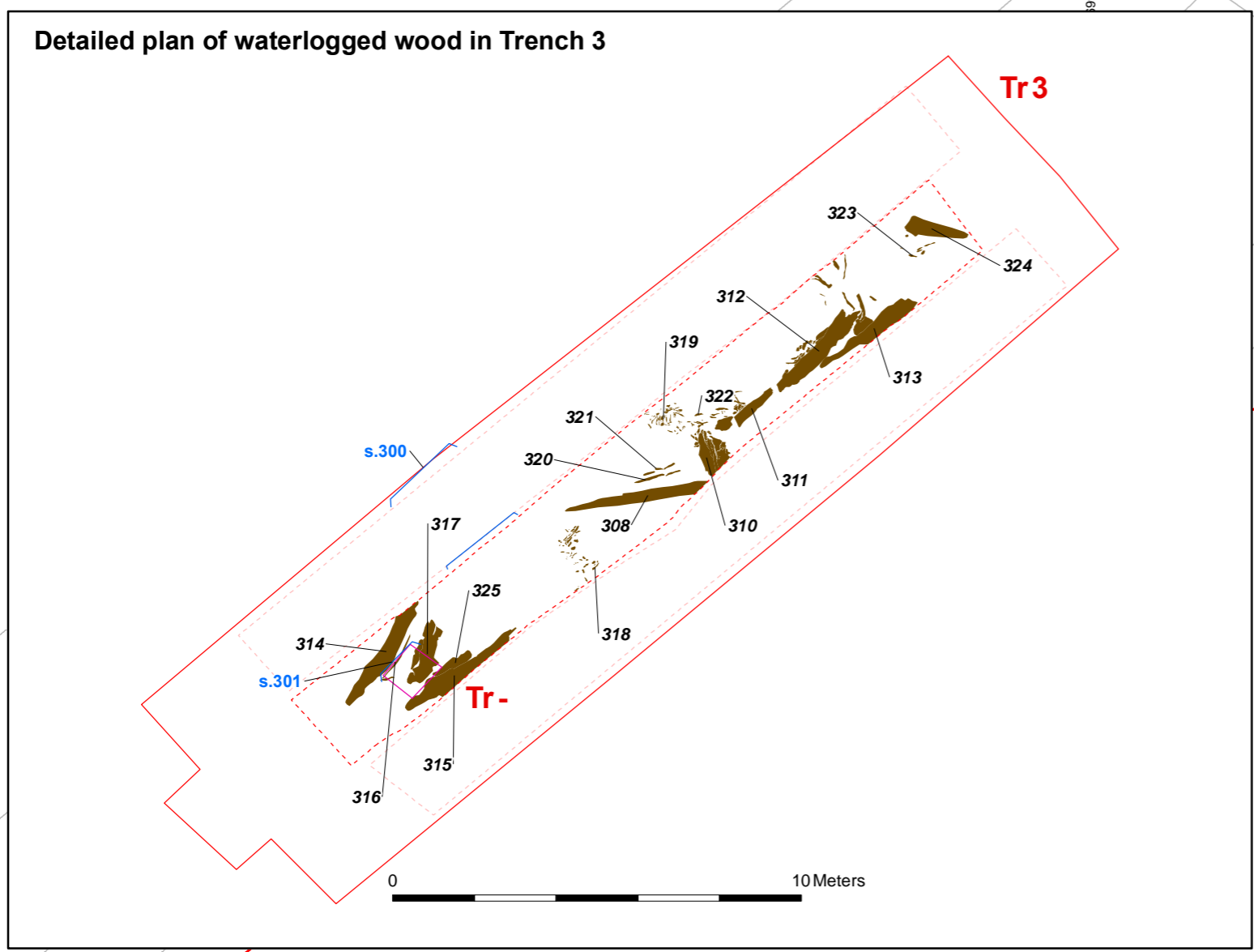

- Site boundary
- Evaluation trench
- Base of trench
- Steps
- Proposed trench
- Test pit
- Feature
- Section
- Waterlogged wood
- Field boundaries (2nd Ed. OS map)

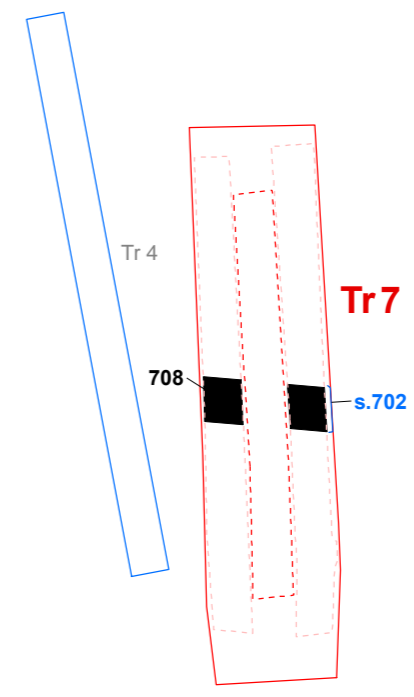
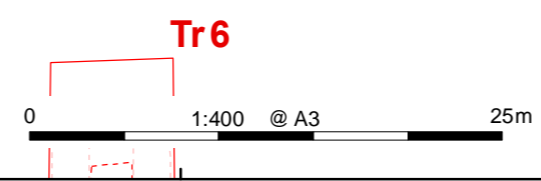
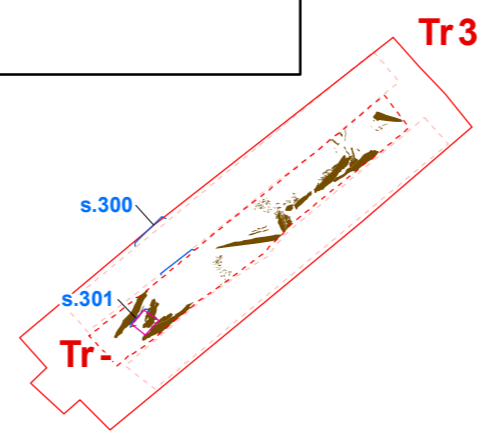
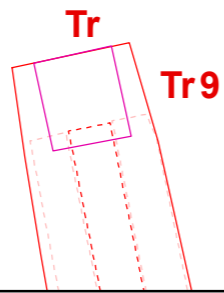

Contains Ordnance Survey data © Crown copyright and database right 2020, provided by client

Figure 6: Detailed plan of Trenches 3 and 7

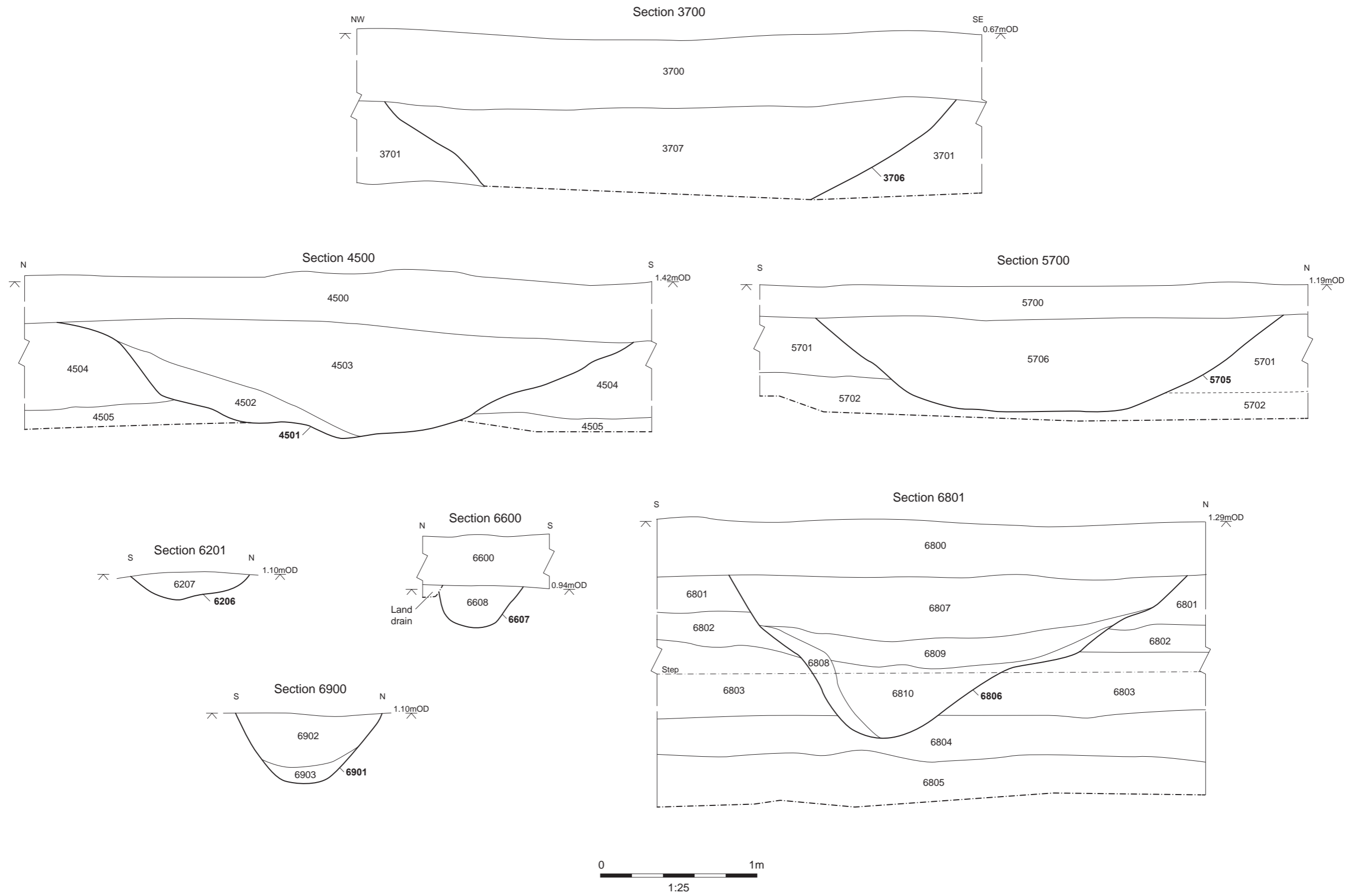

Figure 7: Sections 3700, 4500, 5700, 6201, 6600, 6801 and 6900



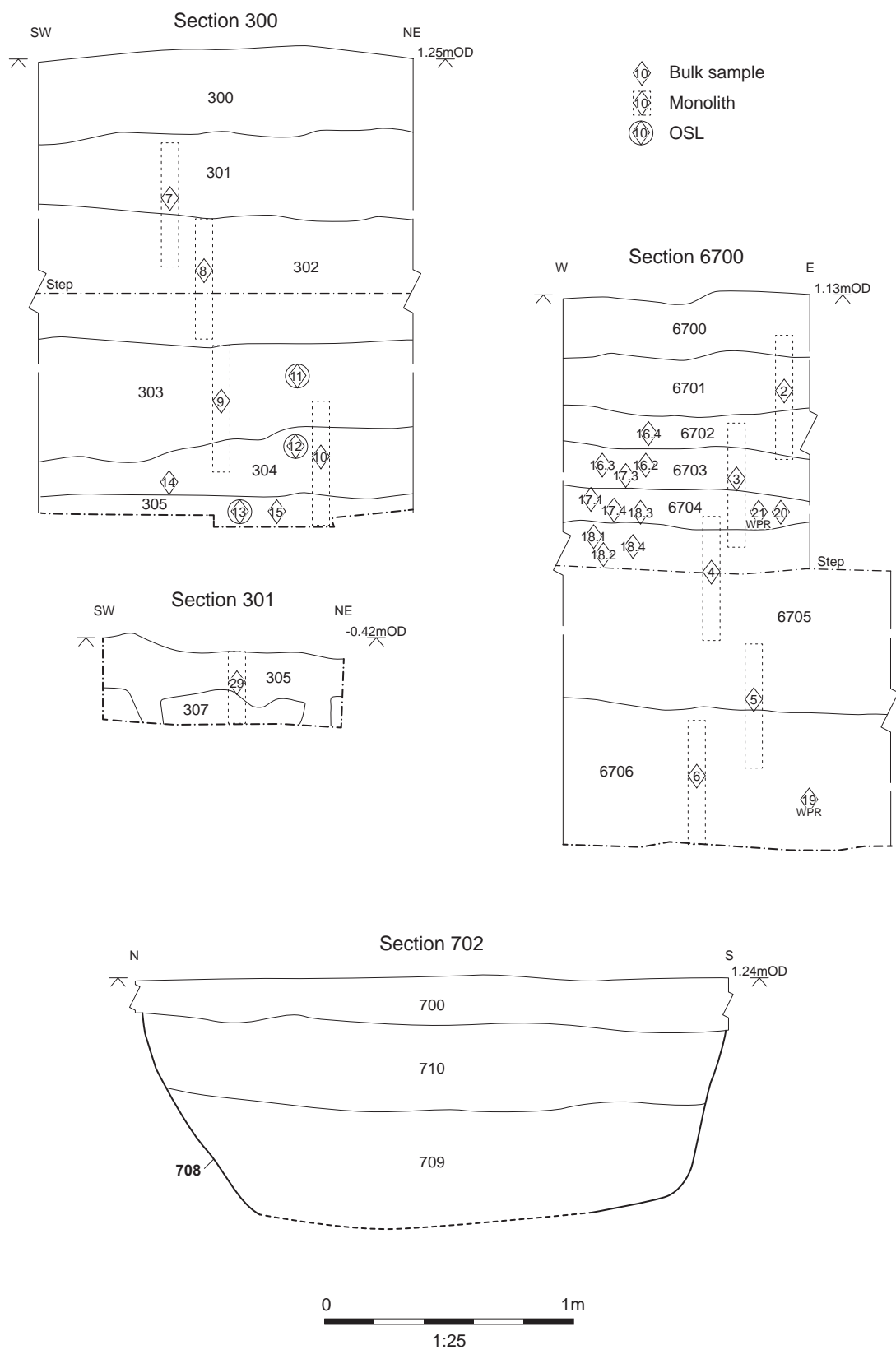
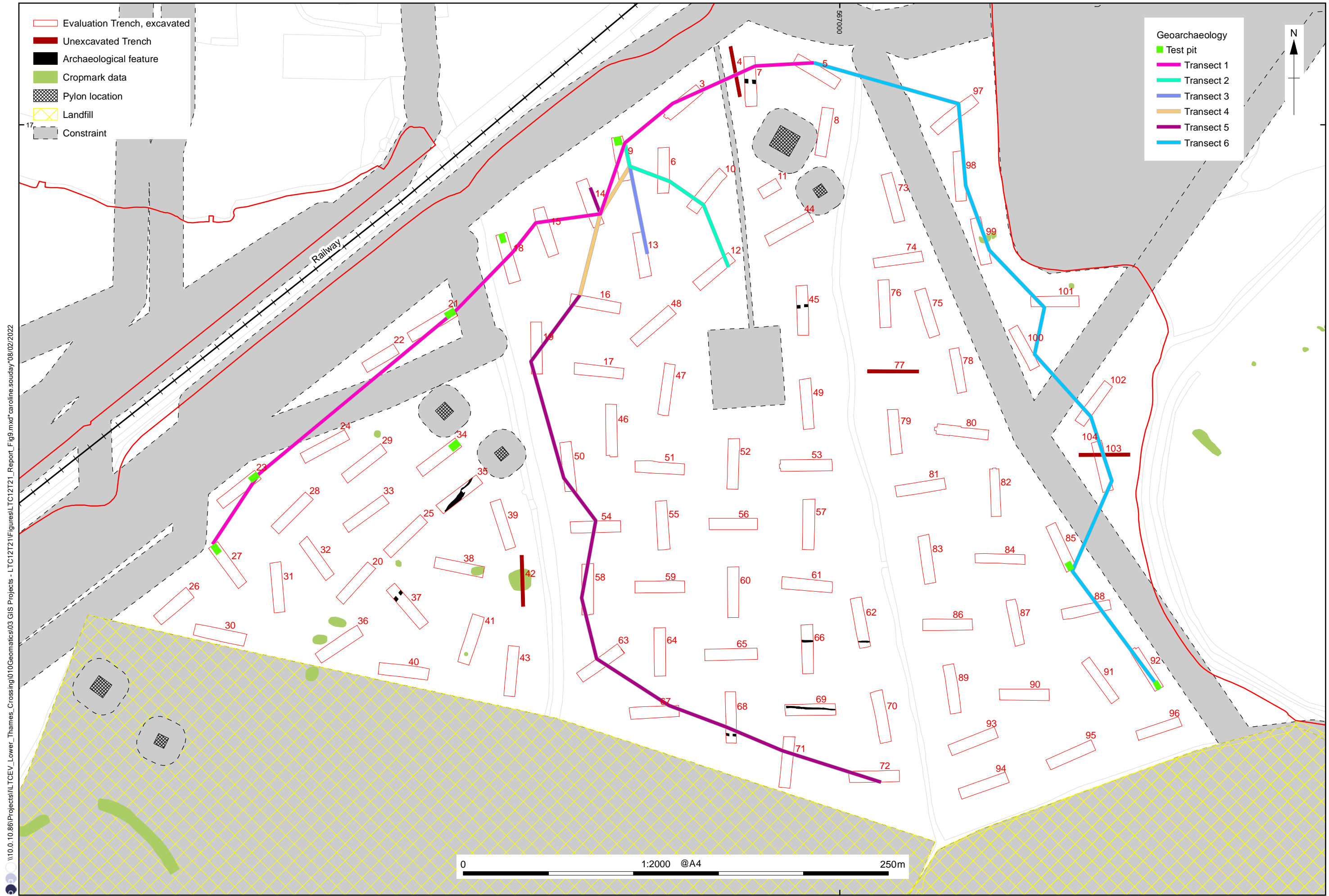

Figure 8: Sections 300, 301, 702 and 6700



I:\10.0.10.86\Projects\Lower\_Thames\_Crossing\GIS\Geomatics\03 GIS Projects - LTC12721\Figures\LTC12721\_Report\_Fig9.mxd\*caroline.soudsby\*08/02/2022

Contains Ordnance Survey data © Crown copyright and database right 2020, provided by client

Figure 9: Geotechnical transect locations

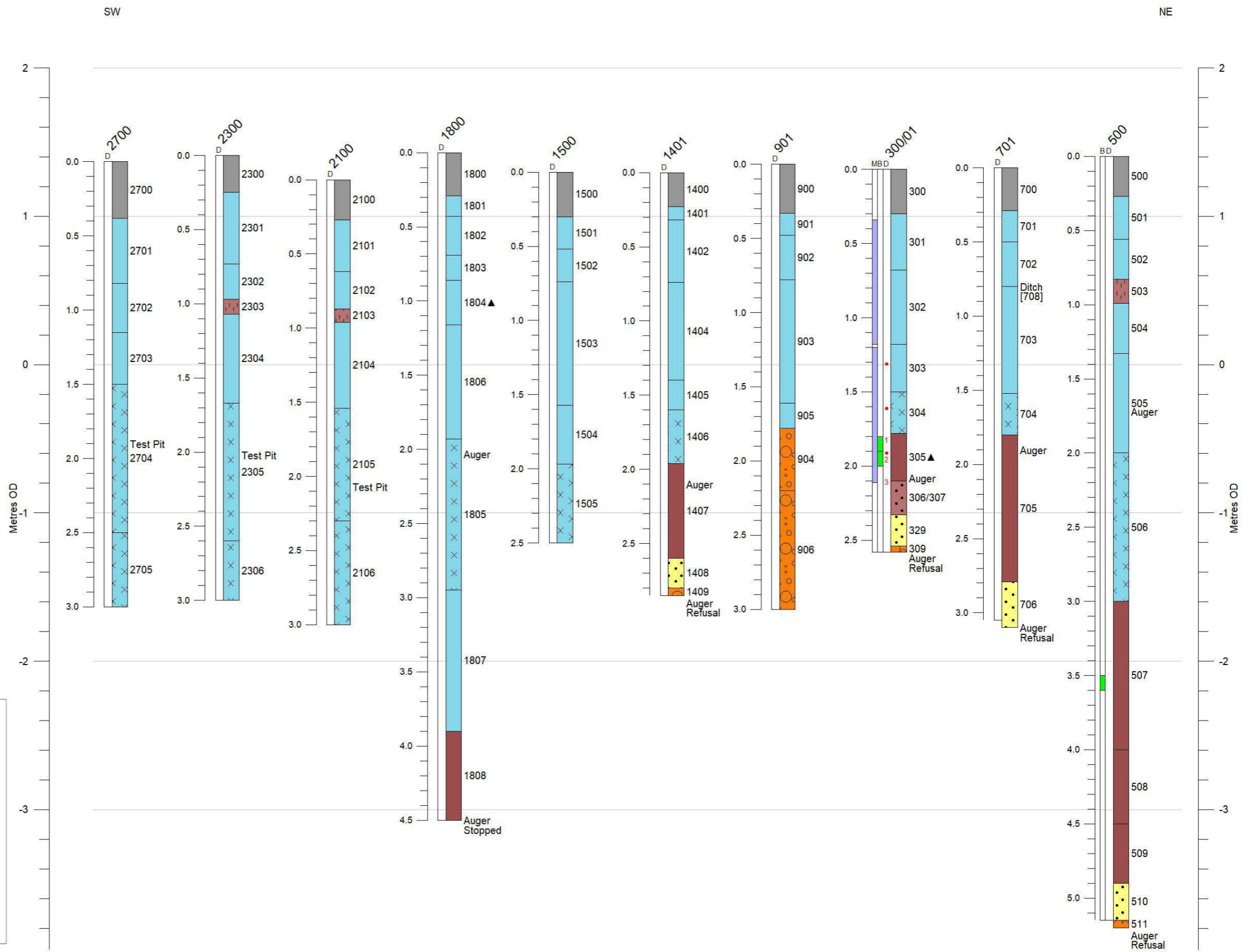

Key	
▲	Worked flint
•	OSL sample (D)
1	Radiocarbon dates (D)
2	Radiocarbon dates (D)
3	Radiocarbon dates (D)
▭	Monolith sample (M)
■	Bulk samples (B)
■	Topsoil/ploughsoil
■	Alluvium (clay/silt)
■	Alluvium (detrital)
■	Alluvium (laminated)
■	Alluvium (organic)
■	Stabilisation/buried soil
■	Peat
■	Sand/silt (organic/detrital)
■	Sand (fluvial)
■	Sand and gravel (fluvial)

Figure 10: Geoarchaeological Transect 1, Trenches 27, 23, 21, 18, 15, 14, 9, 3, 7 and 5

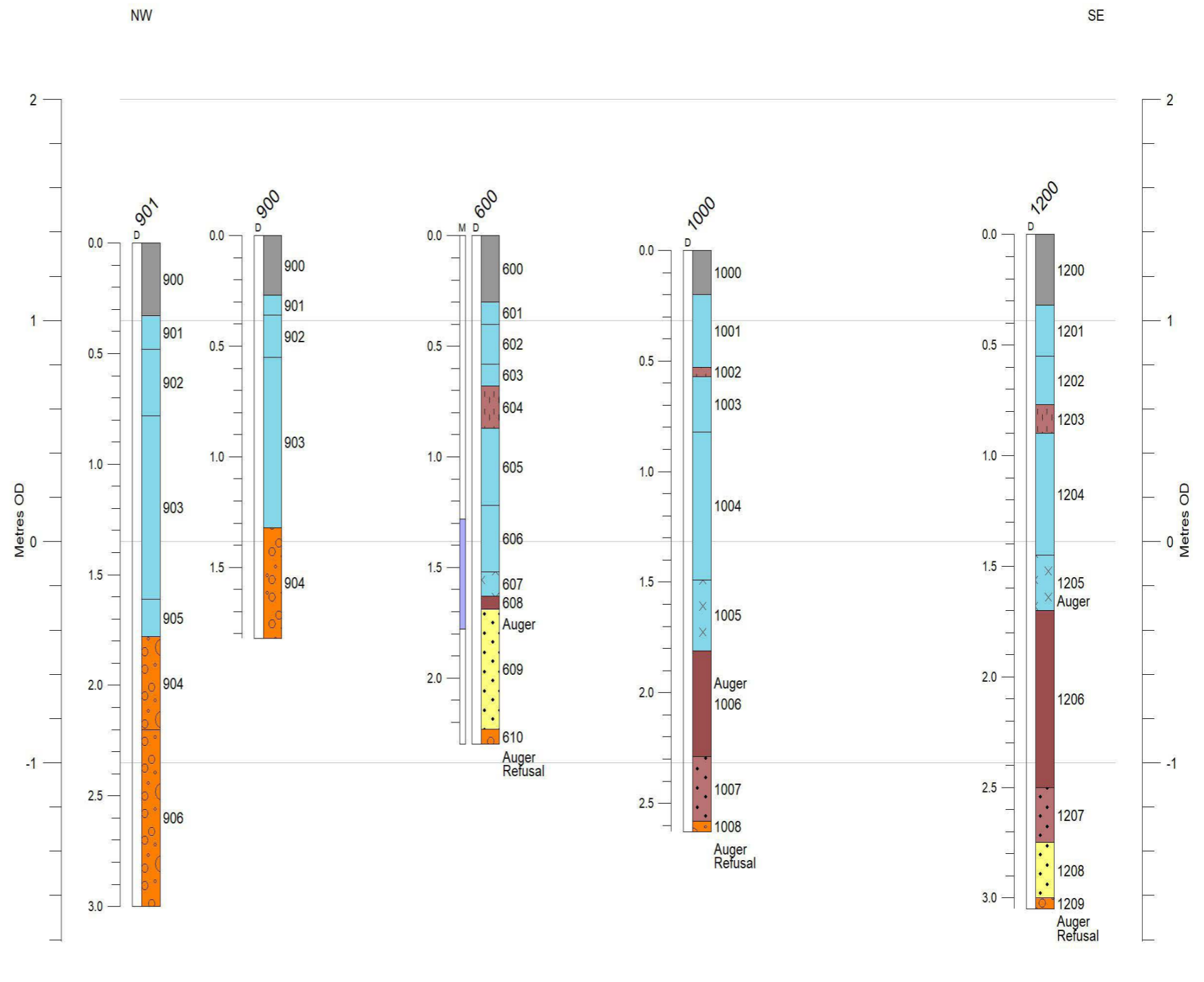

Key	
▲	Worked flint
•	OSL sample (D)
■	Monolith sample (M)
■	Bulk samples (B)
■	Topsoil/ploughsoil
■	Alluvium (clay/silt)
■	Alluvium (detrital)
■	Alluvium (laminated)
■	Alluvium (organic)
■	Stabilisation/buried soil
■	Peat
■	Sand/silt (organic/detrital)
■	Sand (fluvial)
■	Sand and gravel (fluvial)

Figure 11: Geoarchaeological Transect 2: Trenches 9, 6, 10 and 12

Key	
▲	Worked flint
●	OSL sample (D)
■	Monolith sample (M)
■	Bulk samples (B)
■	Topsoil/ploughsoil
■	Alluvium (clay/silt)
■	Alluvium (detrital)
■	Alluvium (laminated)
■	Alluvium (organic)
■	Stabilisation/buried soil
■	Peat
■	Sand/silt (organic/detrital)
■	Sand (fluvial)
■	Sand and gravel (fluvial)

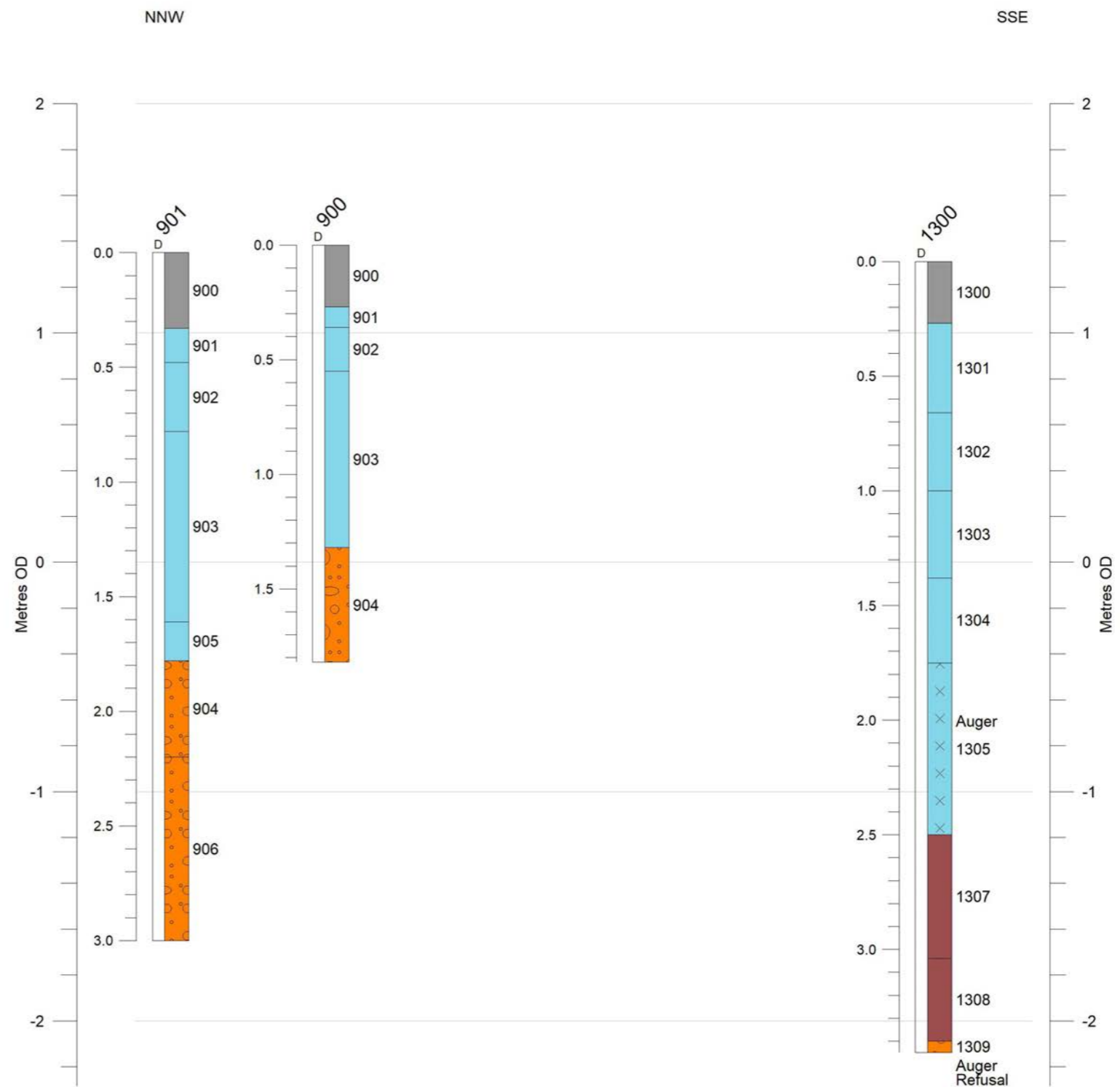
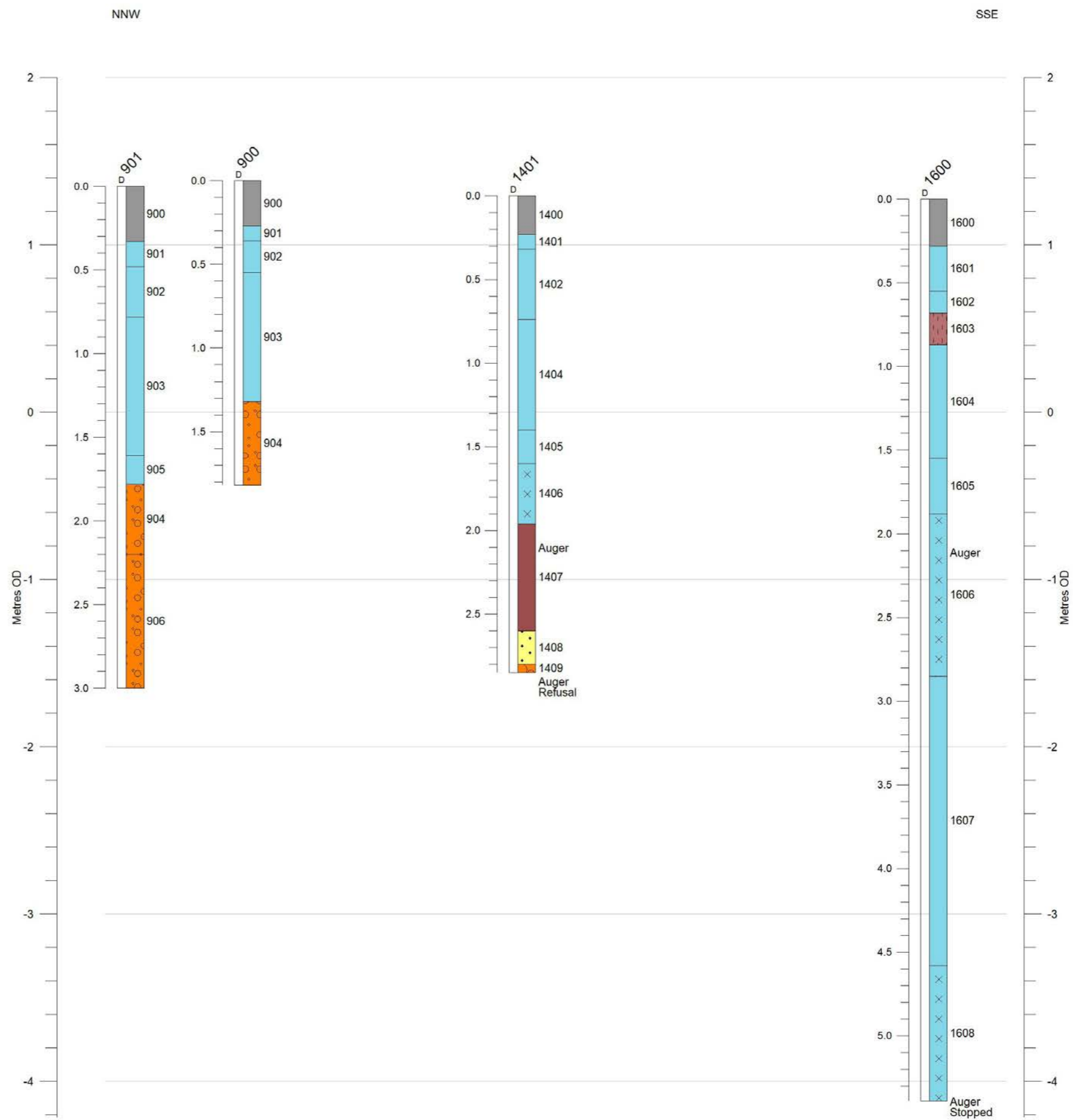

Figure 12: Geoarchaeological Transect 3: Trenches 9 and 13



Key			
▲	Worked flint	■	Topsoil/ploughsoil
●	OSL sample (D)	■	Alluvium (clay/silt)
■	Monolith sample (M)	■	Alluvium (detrital)
■	Bulk samples (B)	■	Alluvium (laminated)
		■	Alluvium (organic)
		■	Stabilisation/buried soil
		■	Peat
		■	Sand/silt (organic/detrital)
		■	Sand (fluvial)
		■	Sand and gravel (fluvial)

Figure 13: Geoarchaeological Transect 4: Trenches 9, 14 and 16

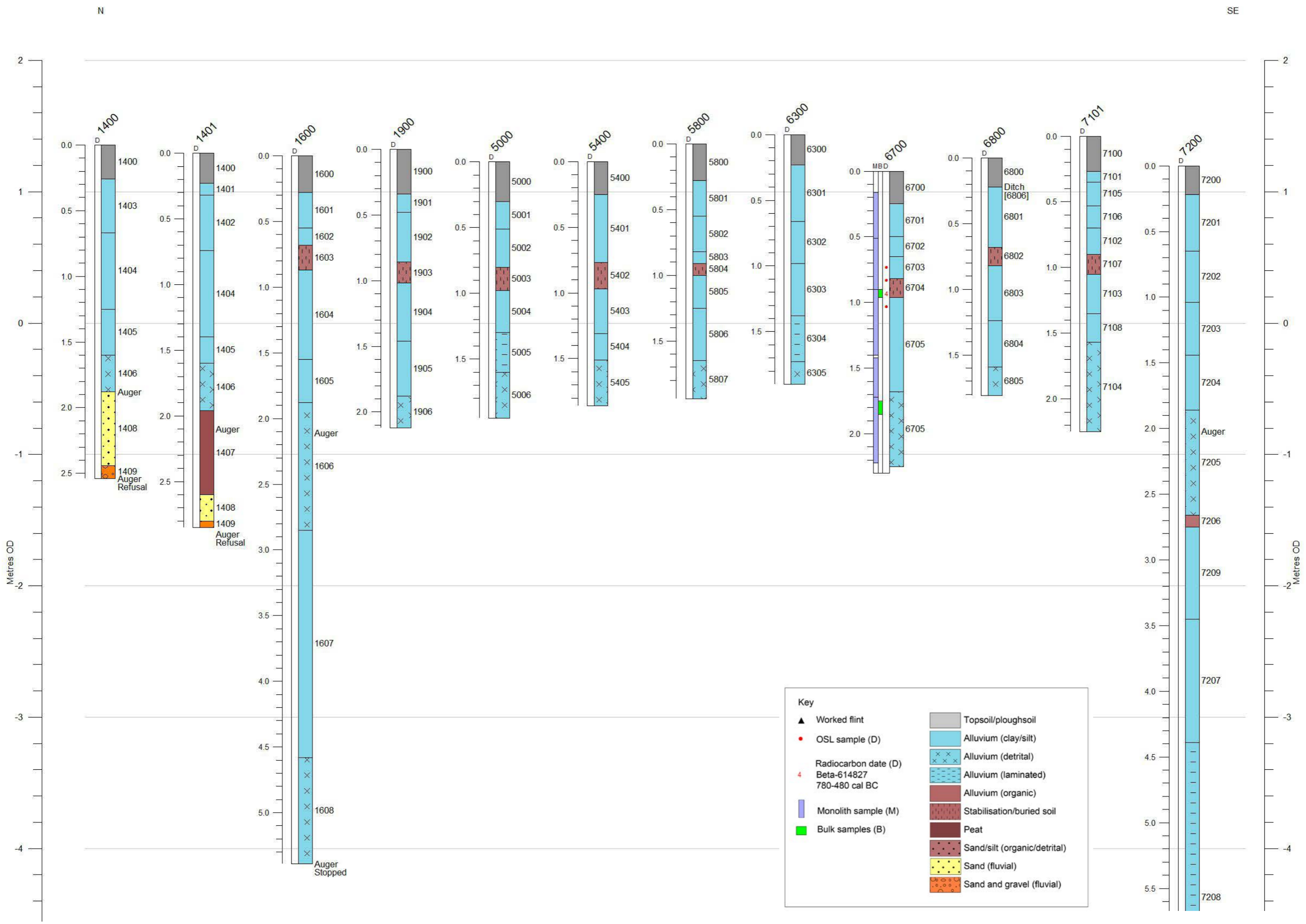

Figure 14: Geoarchaeological Transect 5: Trenches 14, 16, 19, 50, 54, 58, 63, 67, 68, 71 and 72

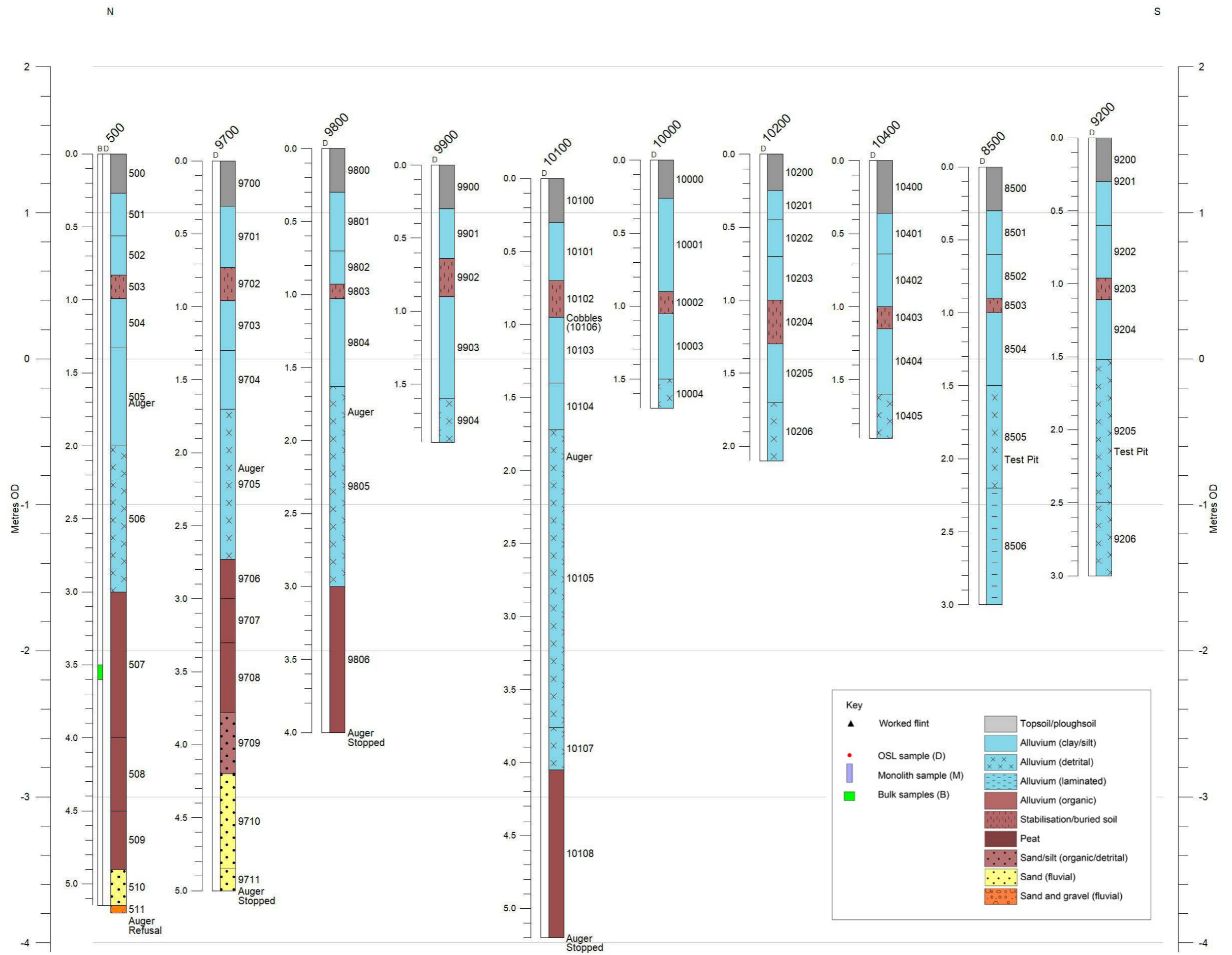

Figure 15: Geoarchaeological Transect 6: Trenches 5, 97, 98, 99, 101, 100, 102, 104, 85 and 92





Plate 1: Ditch 4501, looking east



Plate 2: Flint spread 10106, looking east



Plate 3: General view of Trench 3, looking north-east



Plate 4: Detail of waterlogged wood 308, looking south



Plate 5: Weathered surface of waterlogged wood 308, looking south



Plate 6: Extent of the peat in Trench 14



Plate 7: Trench 9, Section 901, Pleistocene terrace gravel deposits overlain by Holocene alluvium

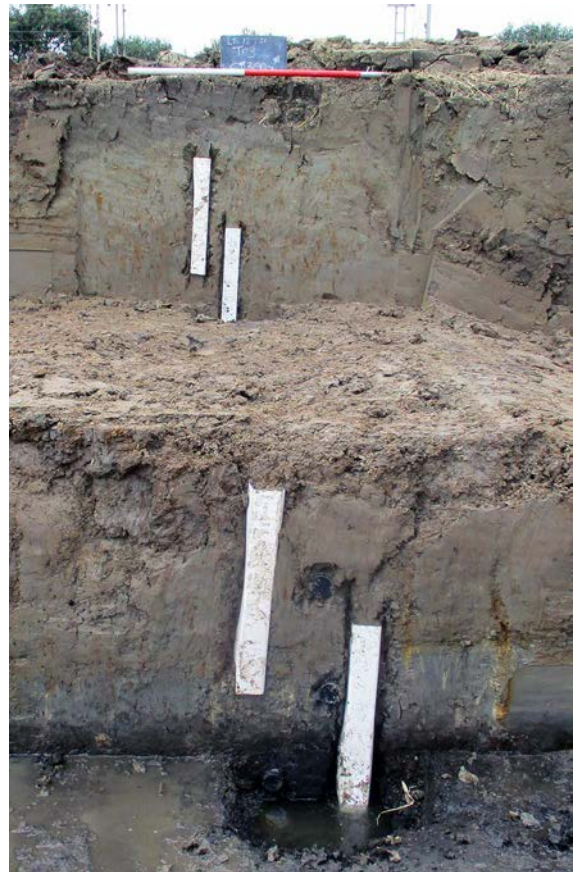

Plate 8: Trench 3, Section 300, peat deposits overlain by gleyed and oxidised Holocene alluvium, with monoliths samples

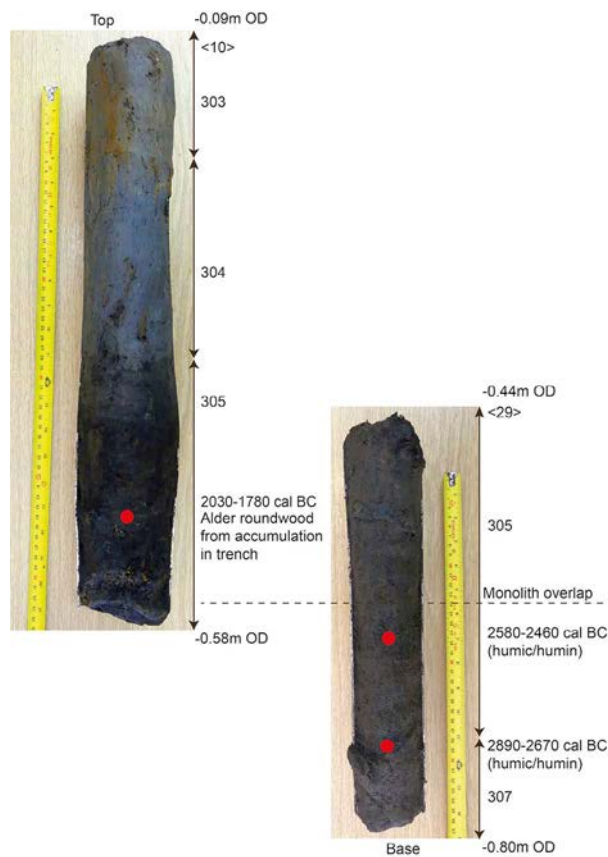

Plate 9: Trench 3, Section 300/301, monoliths <10> and <29> through the peat showing the location of the radiocarbon samples



Plate 10: Trench 10, Section 1000, peat deposits overlain by gleyed and oxidised Holocene alluvium

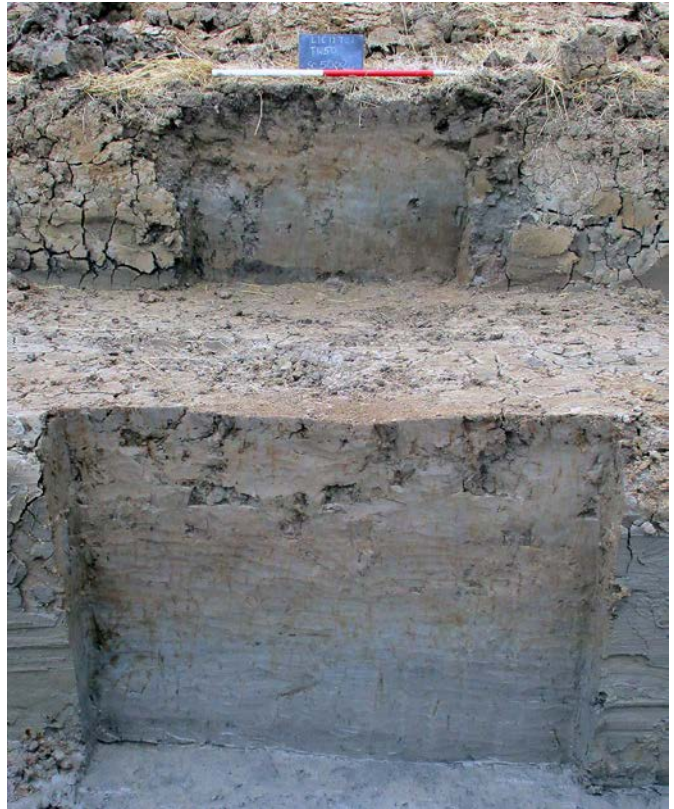

Plate 11: Trench 50, Section 5000, Holocene alluvial sequence (laminated towards base) with intercalated stabilization/buried soil horizon in the upper sequence

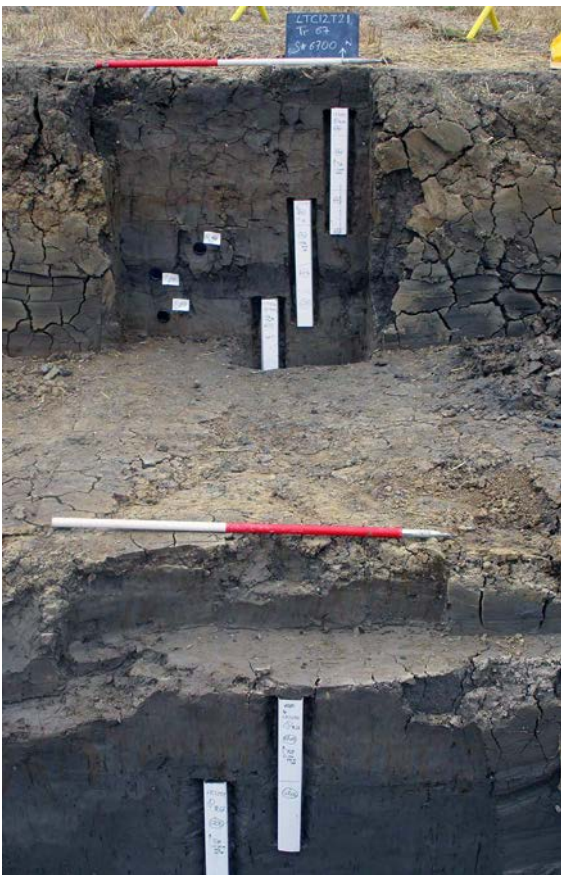

Plate 12: Trench 67, Section 6700, Holocene alluvium sequence with intercalated stabilization/buried soil horizon with monolith samples



Plate 13: Trench 101, Section 10100, Holocene alluvium sequence with intercalated stabilization/buried soil horizon

If you need help accessing this or any other National Highways information, please call **0300 123 5000** and we will help you.

© Crown copyright 2022.

You may re-use this information (not including logos) free of charge in any format or medium, under the terms of the Open Government Licence. To view this licence:

visit [www.nationalarchives.gov.uk/doc/open-government-licence/](http://www.nationalarchives.gov.uk/doc/open-government-licence/)

write to the **Information Policy Team, The National Archives, Kew, London TW9 4DU**, or email [psi@nationalarchives.gsi.gov.uk](mailto:psi@nationalarchives.gsi.gov.uk).

Mapping (where present): © Crown copyright and database rights 2022 OS 100030649. You are permitted to use this data solely to enable you to respond to, or interact with, the organisation that provided you with the data. You are not permitted to copy, sub-licence, distribute or sell any of this data to third parties in any form.

If you have any enquiries about this publication email [info@nationalhighways.co.uk](mailto:info@nationalhighways.co.uk) or call **0300 123 5000\***.

\*Calls to 03 numbers cost no more than a national rate call to an 01 or 02 number and must count towards any inclusive minutes in the same way as 01 and 02 calls.

These rules apply to calls from any type of line including mobile, BT, other fixed line or payphone. Calls may be recorded or monitored.

Printed on paper from well-managed forests and other controlled sources when issued directly by National Highways.

Registered office Bridge House, 1 Walnut Tree Close, Guildford GU1 4LZ

National Highways Company Limited registered in England and Wales number 09346363